



Climate Control Solutions

Literature Assembly

911-0866

Contains the following:

2100-034(G)	User Guide
2100-479	Leak Test Evacuation Charging
2100-790(A)	Wall Mount Pkg H/P Manual
2110-1579(A)	Replacement Parts Manual
7960-420	Warranty



USER'S APPLICATION GUIDE AND TECHNICAL PRODUCT OVERVIEW

Manual: 2100-034G
Supersedes: 2100-034F
Date: 12-17-20

Bard Manufacturing Company, Inc.
Bryan, Ohio 43506
www.bardhvac.com



BARDHVAC.COM

Climate Control Solutions

General Information

The User's Application Guide covers a wide range of heating and cooling products manufactured by Bard Manufacturing Company. It is intended to be a general guide for care and operation of typical systems and covers the most important features you should be aware of and are responsible for as the user of the equipment.

Because our product offerings are so varied and can be equipped with many features and options, it is not possible to cover all aspects of what your specific system may be configured for. Some systems may be quite simple in features to provide basic cooling and possibly heating, while other systems may also incorporate various ventilation technologies, dehumidification circuits and many different internal controls as well as room temperature controls. Therefore, you should request a detailed operation sequence and explanation of any special features from your installer and/or service company and also have them instruct you as to any routine maintenance procedures you are responsible for.

Contents

Overview	3	Unit Operation	18
Documentation	4	Air-to-Air Cooling Products (Air Conditioners)	18
Unit Literature Assembly – Documentation Provided with Your Units	4	Air-to-Air Cooling and Heating Products (Heat Pumps)	18
Unit Installation	5	Cooling Mode	18
WALL MOUNT Products – Mounting the Product on Wall Surface	5	Heating Mode	18
WALL MOUNT Products – Clearances for Outdoor Condenser Fan Airflow	6	Water-to-Air Cooling and Heating Products (Geothermal Heat Pumps)	19
WALL MOUNT Products – Clearances for Indoor Supply and Return Airflow	6	Cooling Mode	19
WALL MOUNT Products – Condensate and Defrost Drainage	7	Heating Mode	19
I-TEC and Q-TEC Products – Installing the Product Inside a Room	8	Water Supply Systems	19
I-TEC and Q-TEC Products – Clearances for Outdoor Condenser Fan Airflow	8	Dehumidification and Ventilation Operation	20
I-TEC and Q-TEC Products – Clearances for Indoor Supply and Return Airflow	9	Dehumidification (Air-to-Air or Water-to-Air Systems)	20
I-TEC Air Path	9	Ventilation Options (Air-to-Air or Water-to-Air Systems)	20
Q-TEC Air Path	9	Troubleshooting	21
I-TEC and Q-TEC Products – Condensate Drainage .	10	All Units – Troubleshooting	21
All Products – Power Supply Verification	11		
Field-Supplied Voltage	11		
Single and Three Phase Power	11		
Hertz (Frequency)	11		
Unit Maintenance	12		
All Products – Filters and Filter Servicing	12		
Outdoor Unit Wall Mount Room Air Filters	12		
WALL MOUNT Products – Filters and Filter Servicing	13		
I-TEC Indoor Products – Filters and Filter Servicing	14		
Q-TEC Indoor Products – Filters and Filter Servicing	15		
All Products – Coil Cleaning	16		
Equipment Corrosion Protection	16		
All Products – Condenser Airflow	17		

The User's Application Guide and Technical Product Overview covers the following products:



WALL MOUNT
Air Conditioners
and Heat Pumps



I-TEC®
Air Conditioners
and Heat Pumps



Q-TEC™
Air Conditioners
and Heat Pumps

The User's Application Guide and Technical Product Overview covers the following topics:

- Documentation provided by Bard for proper use of your new product.
- Unit installation guidelines.
- Routine unit maintenance.
- Unit operation.
- Unit troubleshooting.

Please use this guide as a general overview regarding unit application, maintenance and troubleshooting. Refer to product installation instructions and supplemental documentation provided with the unit or go to www.bardhvac.com for detailed individual product information.

Documentation

There are two sources of valuable information for your new Bard product:

- Documentation provided with your unit, normally located inside the unit control panel during shipping. This information should be saved once the unit is installed for future maintenance reference or to answer questions about equipment after installation.
- Documentation provided on the internet at www.bardhvac.com. This may be accessed from a desktop computer at the office, a laptop or an internet-capable cell phone at the worksite. Up-to-date documentation is available, along with specification sheets and other valuable resources regarding your new Bard product.

Unit Literature Assembly – Documentation Provided with Your Unit

Bard products are shipped with documentation that when used by a technician with cooling and heating knowledge, can ensure that your product is installed safely, performs optimally and achieves the longest life cycle possible.

Shipped literature includes the following:

- User Manual (this document)
- Installation Instructions
- Replacement Parts Manual
- Wiring Diagrams
- Warranty Information

Installation plays a key part in unit functionality, performance and safety. Product securing and placement, duct design and supply/return location, electrical routing and condensate and defrost drainage all play key roles in making sure a unit will perform per the design specifications.

WALL MOUNT Products – Mounting the Product on a Wall Surface



Outdoor products are normally mounted to an exterior wall surface, including brick, cement block, metal or wood construction. These products are labeled as “WALL MOUNT” units. **Before installation begins, the wall surface should be inspected by a construction professional to ensure it will support the weight of the unit and accessory items.** Approximate weights are available from the product specification sheet, and a safety factor should be designed into the installation. Typical fasteners to attach the unit to the wall using the integrated mounting flanges on both sides of the unit include tap cons, bolts, studs and other fastening devices. The selection of the fasteners to be used needs to be reviewed by a construction professional and decided upon based on the wall construction and fastener strength required. It is important to follow all guidelines and procedures covered in the installation instructions manual provided for the product.

Built-In Mounting Flange Detail:

Outdoor WALL MOUNT products include a mounting flange that is part of the cabinet construction. Ø.375" holes are provided for unit mounting unless specified otherwise in installation instructions.

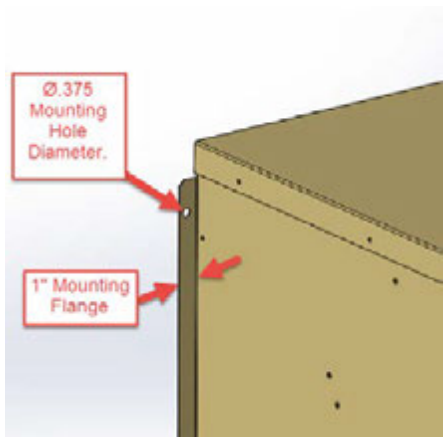

Specification Sheets:

Unit specification sheets provided at www.bardhvac.com include basic unit weights and dimensions (see example below). Ventilation options and other accessories must be added into the total weight of the unit.

Specification Sheet Example

w/Filter (Rated-wet Coil)	
Filter Sizes (inches) STD.	16x25x1
Basic Unit Weight-LBS.	318
Barometric Fresh Air Damper	3.5
Blank-Off Plate	1.0
Motorized Fresh Air Damper	10.0
Commercial Room Ventilator	69.0
Economizer	69.0
Energy Recovery Ventilator	50.0

WALL MOUNT Products – Clearances for Outdoor Condenser Fan Airflow

Unit placement and avoidance of obstructions outside the structure are very critical to unit performance. **Avoid installing the unit in areas that will obstruct outdoor condenser fan airflow or create “pockets” of heated air being exhausted from the condenser coil.** Solid construction fences should not be placed directly in front of the unit without provisions for condenser airflow. Solid exterior walls need to be spaced as far away from units as possible to avoid pockets of heated air causing condenser air recirculation.

Solid barriers located too close to the face or side surfaces (condenser fan inlet and outlet) of the WALL MOUNT can both impede airflow and force heated air to short circuit (be returned) from the condenser outlet to the condenser inlet. Either condition will effectively raise the condensing temperature and pressure reducing cooling capacity and efficiency. In extreme cases, the unit may fail to operate due to high refrigerant pressures inside the unit, and compressor and/or fan motor failure may occur. Clearances given in installation instructions ensure components can be serviced and maintenance can be performed when needed.

National and local electrical codes must be reviewed before unit installation.

Always use common sense when installing products, follow unit clearances given in the installation instructions and contact local Bard distributors when additional knowledge is needed regarding unit clearances for proper unit functionality.

WALL MOUNT Products – Clearances for Indoor Supply and Return Airflow

The Bard unit should be placed in an area where the supply (leaving conditioned air) and return (unit air intake) air paths will be unrestricted. Avoid placing objects in the structure within 24" of the return (unit air intake) grille. Avoid placing objects directly in the path of the supply (conditioned) air grille. This will inhibit the “throw” of the supply air throughout the structure and reduce the cooling and/or heating ability of the unit; in extreme cases, this may cause evaporator coil freezing issues. Supply air must be able to freely circulate conditioned air throughout the structure. Adjustment of supply grille deflectors is often necessary to ensure proper room circulation.

Ducted applications should not exceed the rated duct static pressures given in the unit specification sheets. Special requirements for duct construction and distances to combustible materials need to be followed per the installation instructions when electric heating is used.

WALL MOUNT Products – Condensate and Defrost Drainage

Condensate drainage for air conditioning units needs to be planned before installation. Your new Bard WALL MOUNT product includes provisions to allow condensate water to exit the bottom of the unit. If condensate water is to be routed away from the unit, adequate drain sizing needs to be provided to allow proper drainage for condensate water generation. During normal air conditioning operation, large amounts of condensate water is generated inside the unit as moisture is extracted from the supply air. This is collected in an evaporator pan and drained to either a drainage system (indoor products) or outside the unit cabinet (outdoor products). Evaporator drain traps are not necessary for any of our wall mounted outdoor products, and the use of “standing water” U-shaped traps may be prone to freezing in certain climate zones.

Defrost water drainage from heat pump units needs to be planned before installation. During seasons requiring heating operation, the unit will need to warm the condenser coil to remove frost build-up (defrost). **Outdoor heat pump products include holes in the unit base under the condenser coil for proper water drainage when in the heating defrost cycle. Avoid placing the unit on a pad or blocking the base drainage holes under the condenser coil without proper allowances (6" recommended) for water drainage due to damage caused by freezing conditions.** Without proper drainage, defrost water may freeze causing ice build up and damage the lower portion of the condenser coil.

Condensate Water Drainage:

Unit condensate water exits the base of the unit during cooling operation.



Defrost Water Drainage:

Holes are provided in the front of the unit base for heat pump condensate water drainage.

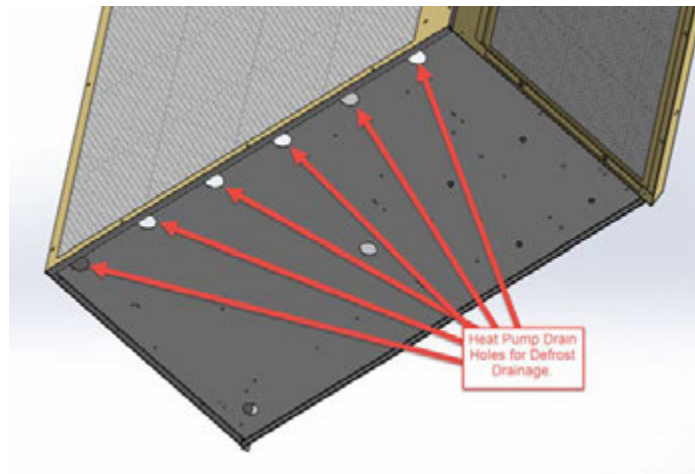

Defrost Water Drainage:

6" clearance is recommended under WALL MOUNT Heat Pump products to allow proper defrost water drainage.

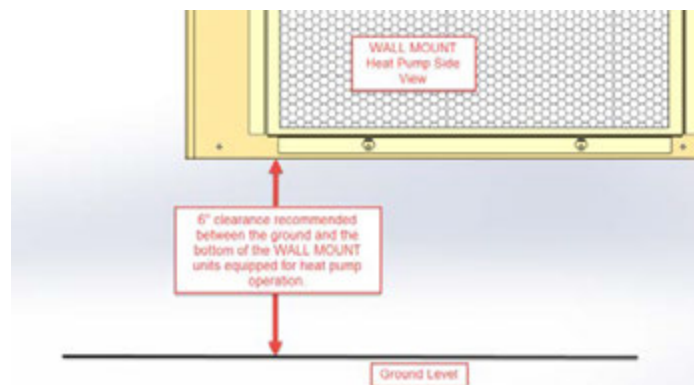

I-TEC and Q-TEC Products – Installing the Product Inside a Room



I-TEC



Q-TEC

Indoor products are normally supported by the floor surface and are adjacent to an interior wall surface, including brick, cement block, metal or wood construction. These products are normally labeled as “I-TEC” or “Q-TEC” units. **Before installation begins, the floor surface should be inspected by a construction professional to ensure it will support the weight of the unit and accessory items.** Approximate weights are available from the product specification sheet, and a safety factor should be designed into the installation.

A sheet metal sleeve is normally installed in the wall allowing vent and condenser fan air to enter and exit the unit. Different sleeve depths are available for installation into various wall depths. Typical fasteners to attach the sleeve to the outside surface of the wall include tap cons and other fastening devices. The I-TEC or Q-TEC unit is then slid up to the wall surface and connected to the sleeve using screws. Trim kits are available to enclose gaps between the wall surface and the unit. A louver grille is used to cover the external wall opening and fasteners used during sleeve installation.

Wall Sleeve:

Wall sleeves allow for outdoor air to enter and exit the unit inside the room.

Air Paths:

Air paths through the unit allow for cooling operation and fresh air to enter the structure (I-TEC shown).

Louver Installation:

Outdoor louvers provide an esthetically pleasing look to the installation and cover the unit opening (I-TEC shown).

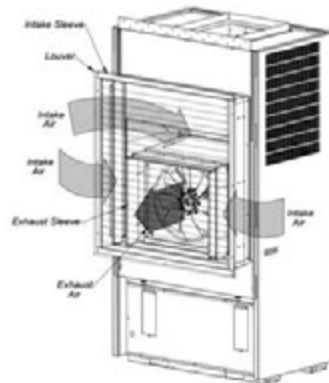
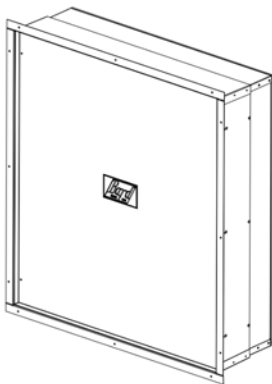

I-TEC and Q-TEC Products – Clearances for Outdoor Condenser Fan Airflow

Solid barriers located too close to the face of the outdoor louver of the I-TEC or Q-TEC can both impede airflow and force heated air to short circuit (be returned) from the condenser outlet to the condenser inlet. Either condition will effectively raise the condensing temperature and pressure reducing cooling capacity and efficiency. In extreme cases, the unit may fail to operate due to high refrigerant pressures inside the unit, and compressor and/or fan motor failure may occur. It is recommended to allow 15' (457.2 cm) in front of unit louver for proper condenser airflow. Always use common sense when installing products, follow unit clearances given in the installation instructions and contact local Bard distributors when additional knowledge is needed regarding unit clearances for proper unit functionality.

I-TEC and Q-TEC Products – Clearances for Indoor Supply and Return Airflow

The Bard unit should be placed in an area where the supply (leaving conditioned air) and return (unit air intake) air paths will be unrestricted. Avoid placing objects inside the room within 24" of the return (unit air intake) louvers or grille. Avoid placing objects directly in the path of the supply (conditioned) air grilles. This will inhibit the “throw” of the supply air throughout the structure and reduce the cooling and/or heating ability of the unit and in extreme cases may cause evaporator coil freezing issues. Ducted applications should not exceed the rated duct static pressures given in the unit specification sheets. Special requirements for duct construction and distances to combustible materials need to be followed per the unit installation instructions when electric heating is used.

I-TEC Air Path

The I-TEC product has been engineered for extremely quiet unit operation and has multiple air paths for air entering and exiting the unit. Room air enters the upper sides to be conditioned (cooled) inside the unit and exits the unit top. The unit will either be ducted to supply registers or have a supply air plenum box installed. A supply air plenum box allows quiet operation without ducting the air leaving the unit. Room air also enters the bottom of both front doors during ventilation operation.

Q-TEC Air Path

The Q-TEC product has been engineered for efficient, economical unit operation and has a mid-mounted front grille for air entering the unit. The unit will either be ducted to supply registers or have a supply air plenum box installed. A supply air plenum box allows quiet operation without ducting the air leaving the unit.

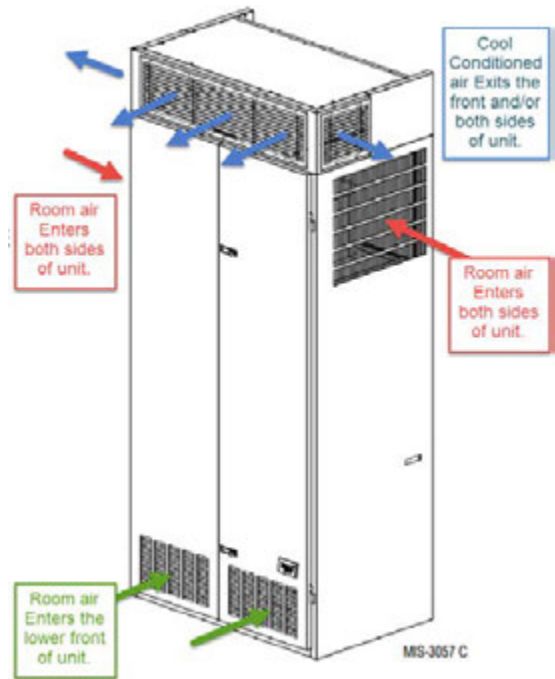

Typical I-TEC Installation

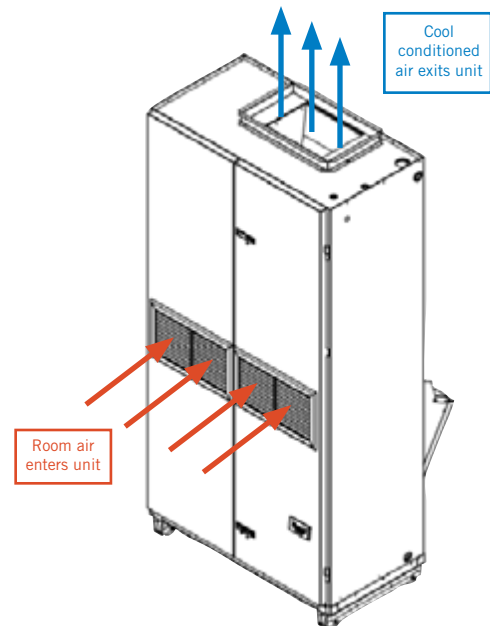

Typical Q-TEC Installation

The I-TEC and Q-TEC product installation instructions contain additional information regarding unit air paths and required clearances. This information may be accessed at www.bardhvac.com.

I-TEC and Q-TEC Products – Condensate Drainage

Condensate drainage for Bard indoor cooling units is a very important part of unit installation. During normal air conditioning operation, large amounts of condensate water are generated inside the unit as moisture is extracted from the supply air. This is collected in an evaporator pan and needs to be drained to an external drainage system. Your new Bard product includes provisions to allow condensate water to exit the unit and fittings will need to be field supplied to connect the unit drain to the building. Adequate drain sizing needs to be provided to allow proper drainage for condensate water generation and restriction in drain lines should be avoided. Evaporator drain traps are not necessary unless required by local codes.

Defrost water for heat pump operation and outdoor water entering the condenser area also needs to be drained out of the unit. The I-TEC product uses a combined defrost and outdoor water drainage system. The Q-TEC has a combined defrost and evaporator drain connection unless an optional in-wall drain box is used. Outdoor water exits the Q-TEC through the wall sleeve. Follow all instructions provided in the unit installation instructions regarding drain connections and sleeve installation to avoid water leakage inside the building or structure.

I-TEC Drain System:

The I-TEC drainage system consists of a manifold drain kit that combines all drains behind the unit to allow connection to the building system.

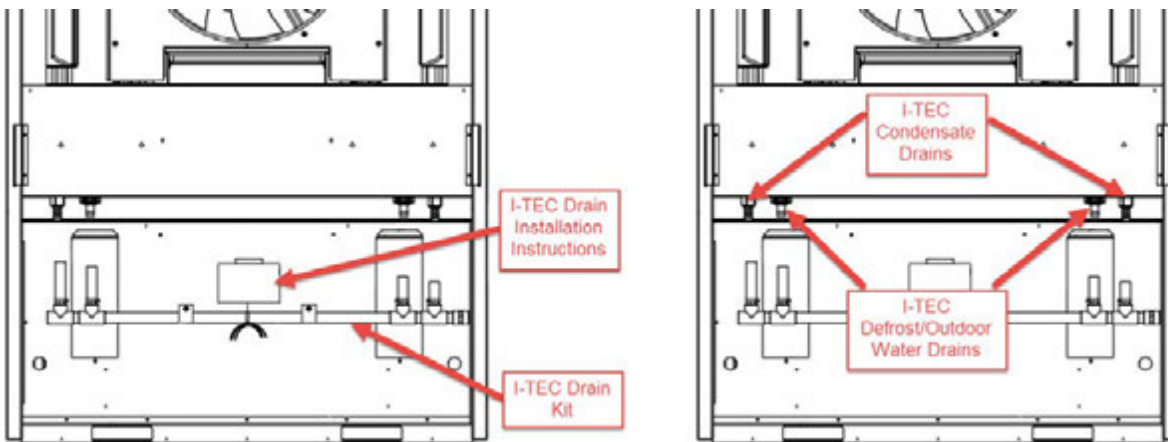

Q-TEC Drain System:

The Q-TEC drainage system consists of a lower right side or lower right rear connection fitting. An optional in-wall drain box may also be purchased as an accessory that allows separate evaporator and defrost water drainage.

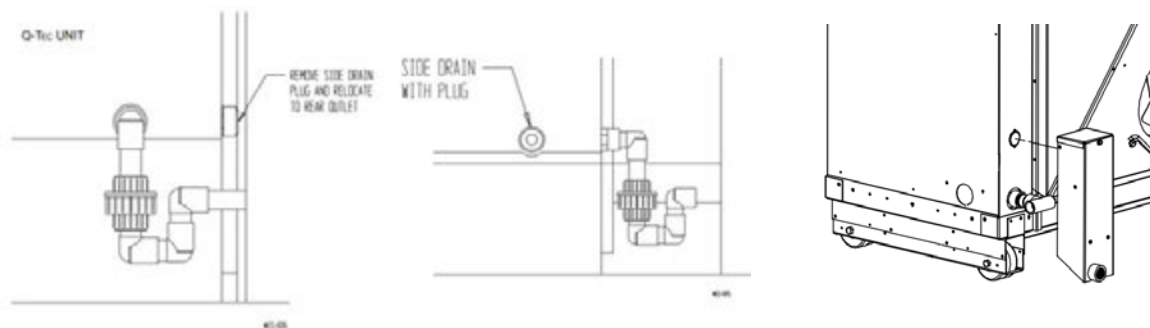

Lower Right Side Drain

Lower Right Rear Drain

Optional In-Wall Drain Box

All Products – Power Supply Verification

It is very important to follow all electrical and mechanical safety guidelines and instructions provided in the product installation instructions. Failure to do so may result in death, injury or product damage.

A proper power supply to your new Bard unit is very important. Be sure to verify the following with a multi-meter or other power measuring device before applying power to your Bard product.

Field-Supplied Voltage

Electrical voltage ratings and proper voltage operating ranges are provided in the unit specification sheets and installation instructions. It is important that power supplied to the unit stay in the specified operating voltage range. Voltage above or below the minimum operating value given could result in improper unit startup, unit shutdown, low unit performance, improper thermostat and unit controller operation, compressor damage and premature failure of functional parts. As a general guideline, it is always best if the power source for the unit supplies the nominal electrical rating value given in the specification sheets, installation instructions and unit serial plate for the product being used. To do so will provide the best unit performance possible from your new Bard product.

Single and Three Phase Power

Bard products are available in single and three phase power options. It is important to connect the proper phase listed on the unit serial plate. Three phase power is often used to reduce energy usage, and units rated for 3 phase operation are equipped with a phase monitor safety device. The phase monitor will not allow unit operation with improper phase connection and a red LED light on the monitor indicates phase wiring issues. Connecting 3 phase power to a single phase unit will result in component damage and improper unit operation. Connecting single phase power to a 3 phase unit will also result in component damage and improper unit operation.

Hertz (Frequency)

Bard products are available in 50hz and 60hz power options. It is important to connect power with the proper hz value listed on the unit serial plate. 60hz power is often used in the United States and Canada and units rated for 50hz operation are normally for international sales outside of this area. Connecting 50hz power to a 60hz unit not rated for 50hz operation may result in component damage and improper unit operation. Some equipment may be rated for 50/60hz operation. Review the unit specifications and installation instructions for further information regarding the power requirements of the unit.

The product installation instructions and unit specification sheets contain additional information regarding unit electrical data. This information may be accessed at www.bardhvac.com.

Unit Maintenance

All Products – Filters and Filter Servicing

All Bard products contain air filters that must be cleaned or replaced on a regular basis.

Keeping air filter(s) clean is the single most important responsibility of the user of the equipment. Each type of system must be equipped with an air filter(s) in the indoor circulating air system to clean the air, keep the system itself clean for peak efficiency and capacity and prolong the useful life of the equipment. DO NOT operate the system without the proper air filters. Filters should be inspected at least monthly and replaced or cleaned (depending on type) as needed. The useful life of an air filter can vary widely depending upon application and use of the equipment, and it is critical to monitor filter condition and establish an acceptable maintenance schedule. Failure to do so will increase operating and repair costs, decrease capacity and efficiency and shorten the service life of the equipment. A common symptom of a dirty filter in the cooling mode is a freeze-up of the indoor coil. The air filters used may be a disposable (throwaway) type or may be a cleanable type that can be thoroughly cleaned, rinsed and reused many times. It is important to make sure that the correct filter size and type for your system is always used. If there is any question as to acceptable filter size or type, review the installation instructions for the specific equipment involved, if available. Otherwise, consult with your installing dealer or service company. Most equipment can have the filters inspected and serviced by the user with no problems. In some instances, because of equipment design or specific installation conditions, it may be necessary to have this procedure done by a qualified service company. Have your installer or service company show you where the filter(s) are and demonstrate the service procedure or make arrangements for them to provide this service on an as-needed basis.

Outdoor Unit Wall Mount Room Air Filters

Wall mount filters are normally accessed from the outside of the building. Bard does offer a return air grille with a filter frame built-in for indoor filter access. The return air filter grille is not acceptable as the only source of filtration if vent options are installed in the wall mount unit.

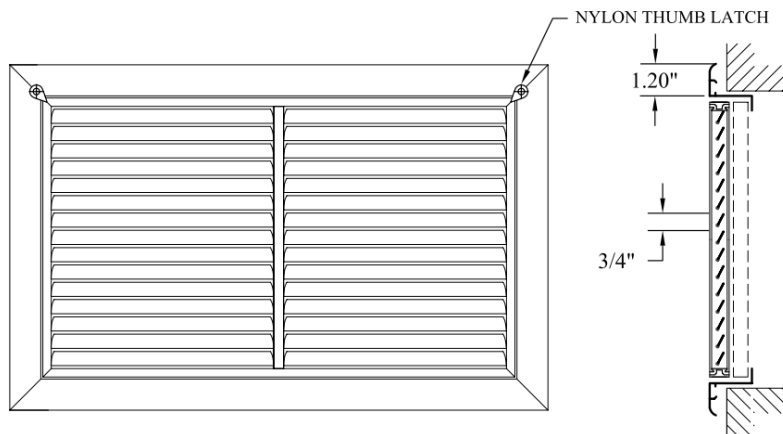

Return Air Filter Grille:

Bard offers the RFG return air filter grille, which may be used in applications where outdoor air is not brought into the structure through vent options. If vent options are used, the filter tray inside the Bard Wall Mount unit must be used.

The product installation instructions contain additional information regarding unit maintenance. This information may be accessed at www.bardhvac.com.

WALL MOUNT Products – Filters and Filter Servicing

The built-in filter tray and room air filters in the wall mount are located in the middle of the cabinet below the indoor blowers. Units with vent options will have a washable screen behind the vent intake panel.



Filter Door:

The unit room air filter is located behind this panel for units without a vent hood.

Vent Intake Panel

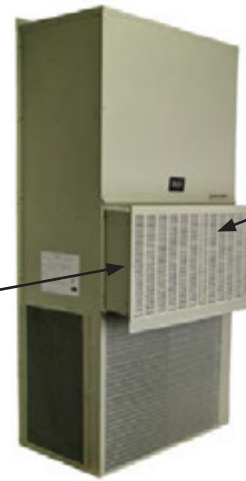

Vent Intake Panel

Vent Hood Door:

The unit indoor filter is located behind this panel for units with a vent hood. The hood contains a washable pre-filter that needs to be cleaned regularly.



Filter Door:

The unit room air filter is located behind this panel.

I-TEC Indoor Products – Filters and Filter Servicing

The I-TEC indoor air conditioners and heat pumps have multiple filters that must be maintained and inspected when servicing the unit. Filters play an important part in proper unit operation and prevent dirt and dust buildup inside the I-TEC and the room the unit is installed in. To access the unit filters, open the front hinged doors by unlocking the door latches. The doors fold outward and are on hinges with lift-off pins. Use care when opening doors. If doors are lifted off of the hinge pins, use care as the dense insulation used for sound reduction causes the doors to be heavy.

The upper section of the unit contains two 2" x 24" x 30" throwaway filters as standard with every unit. MERV ratings of the filter are available up to MERV13. These filters filter the air used for cooling inside the classroom or structure and should be changed regularly.

If the unit has an air intake vent option installed, two 1" x 12" x 20" filters are located in the lower section of the front doors behind the louvers. These filters help keep the vent option clean and operating properly.

Two washable filters are also installed in the air intake vent option. These should be inspected during servicing and cleaned when necessary. The washable filters are used to remove dirt and dust from outdoor air that is entering the vent area. If at any time these filters are damaged, they must be replaced with Bard-approved filters.

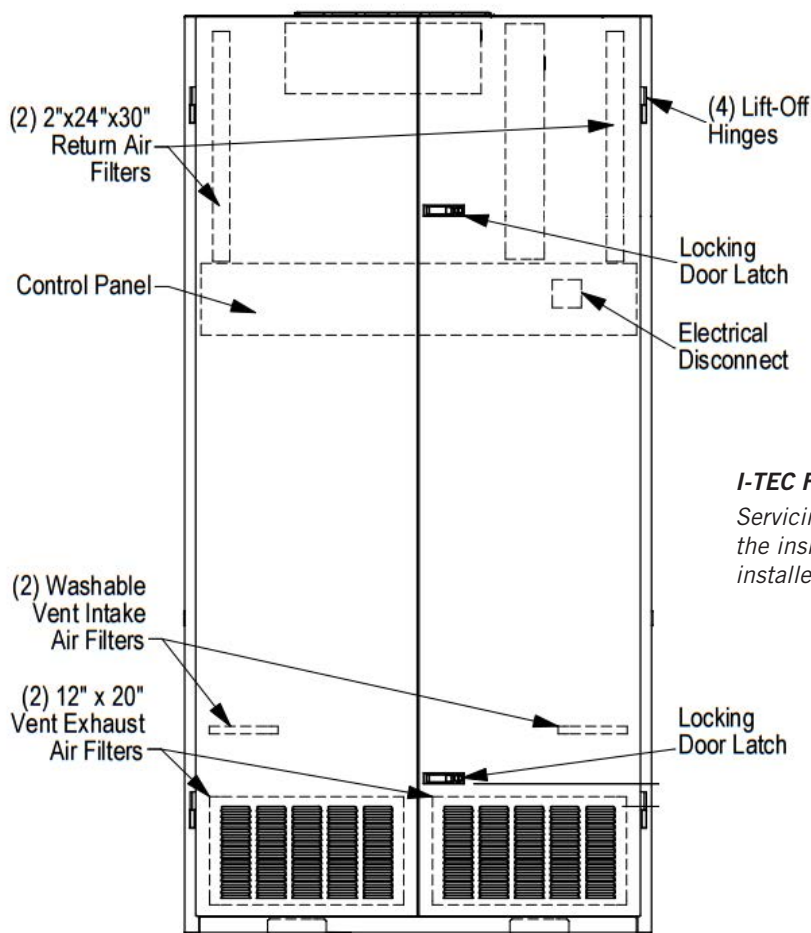

I-TEC Filter Locations:

Servicing the filters in your unit will help keep the inside of the unit clean and also the area it is installed in.

The I-TEC product installation instructions contain additional information regarding unit maintenance. This information may be accessed at www.bardhvac.com.

Q-TEC Indoor Products – Filters and Filter Servicing

The Q-TEC indoor air conditioners and heat pumps have two room air filters that must be replaced when servicing the unit. Filters play an important part in proper unit operation and prevent dirt and dust buildup inside the Q-TEC and the room the unit is installed in. To access the unit filters, open the front hinged door by unlocking the door latch. The door folds outward and is on hinges with lift-off pins. Use care when opening doors. If the door is lifted off of the hinge pins, use care as the insulation and louver grille cause the door to be heavy.

The upper section of the Q-TEC contains two 1" throwaway filters standard with every unit. These filters filter the air used for cooling inside the classroom or structure and should be changed regularly.

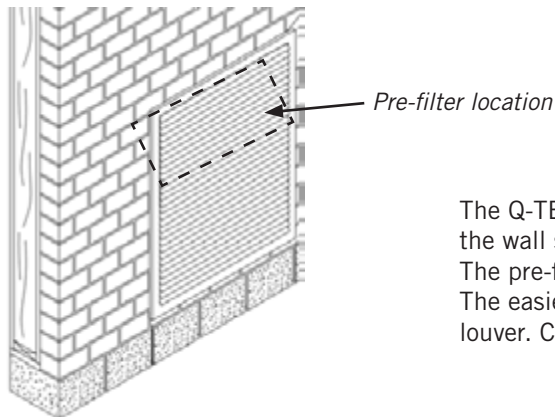
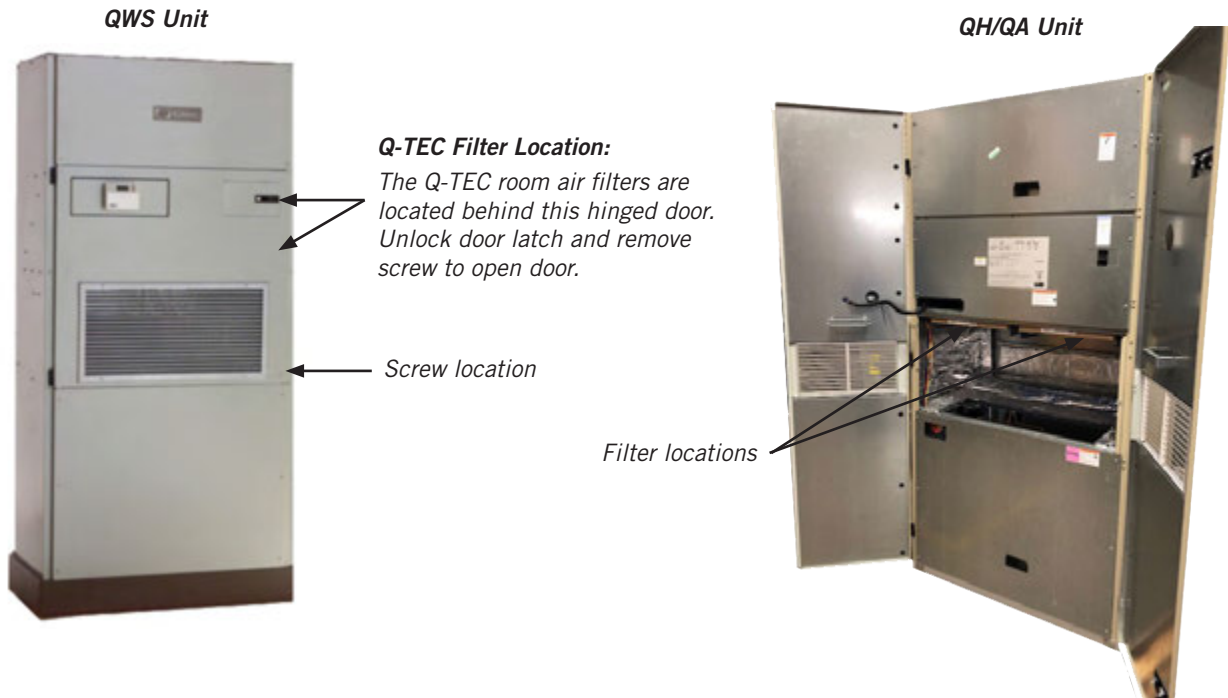

The Q-TEC will have a permanent pre-filter installed inside the wall sleeve if air intake vent options are inside the unit. The pre-filter must be inspected and cleaned when necessary. The easiest way to remove the pre-filter is through the outdoor louver. Clean the pre-filter with soapy water.

The Q-TEC product installation instructions contain additional information regarding unit maintenance. This information may be accessed at www.bardhvac.com.

All Products – Coil Cleaning

The outdoor coil must be kept clean and free of any airborne debris, which can accumulate over time. Large volumes of air are circulated over the coil, and airborne debris such as lint, dust, materials shed from trees, paper or other types of airborne material that can become airborne can collect on the entering coil surface. The outdoor coil must dissipate heat during the cooling mode and for a heat pump, also absorb heat during the heating mode. If the coil is dirty and matted with debris, the airflow across the coil will be reduced causing poor performance, increased operating run time and associated utility bills and in extreme conditions can shorten the useful life of the equipment.

Depending on the specific equipment involved, the surface that can accumulate debris can be on the opposite side that is exposed to view when standing in front of the machine. Closely review the machine when operating to see which direction or path the airflow takes as it moves through the machine. If the air inlet side of the coil is hidden, try to observe the back (hidden) side by looking into the side grilles, using a flashlight if necessary. While the user of the equipment needs to be aware of the potential of clogging of the outdoor coil surface, actual cleaning of the outdoor coil should not be attempted under most circumstances. If the user should attempt this procedure on their own, never do so without first having the installing dealer or service company instruct you in the proper procedure and technique.

WARNING: Do not open or enter the equipment without first turning off the electrical service disconnect. Failure to do so can result in personal injury due to moving parts and/or electric shock hazard resulting in death.

Other conditions that can cause reduction of airflow across the outdoor coil are flowers, shrubbery or other growth too near the outdoor coil air inlet and outlet openings. These living things, especially as they mature and grow, will be just as effective in blocking the airflow and create the same problems as will stacking things against the equipment. These conditions can be easily managed and controlled by the user, as they do not require actually entering into the equipment enclosure, which should only be done by qualified service technicians.

Equipment Corrosion Protection

1. Avoid having any lawn sprinkler spray directly on the equipment, especially if from a brackish water source.
2. In coastal areas or corrosive environments, locate equipment as far away from the corrosion source as feasible. Units exposed directly to salt spray should be coated by a secondary protective coating operation to reduce corrosion on copper tubing, fasteners, motors and other metal parts. Coils should be ordered with a corrosion protective coating. Contact Bard for coating options.
3. Frequent cleaning and waxing of the cabinet using a good automobile polish will help extend its original appearance and protect painted surfaces.

The product installation instructions contain additional information regarding unit coil cleaning. This information may be accessed at www.bardhvac.com.

All Products – Condenser Airflow

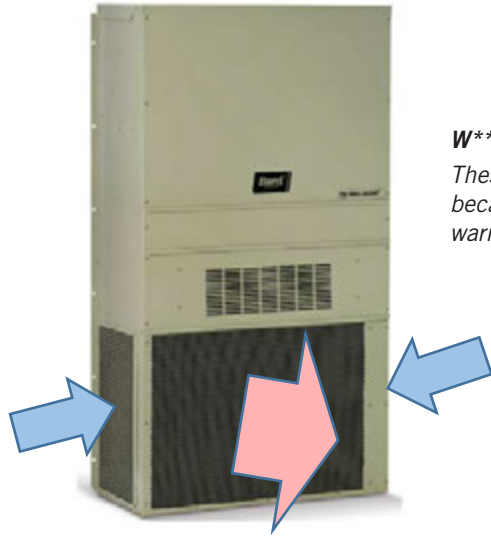

WA, W**H, T**H, T**S, W*RV Wall Mount Units:**

These units are called “blow through condenser airflow” units because they draw cool outdoor air from the sides and blow the warm condenser air exiting the coil through the front grille.

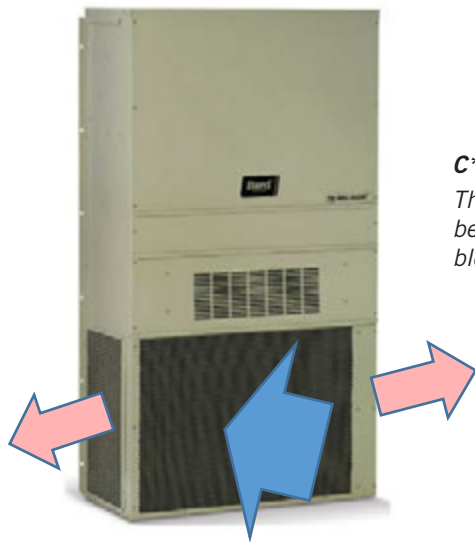

CH Wall Mount Units:**

These units are called “draw through condenser airflow” units because they draw cool outdoor air in the front through the coil and blow the exiting warm condenser air through the unit sides.

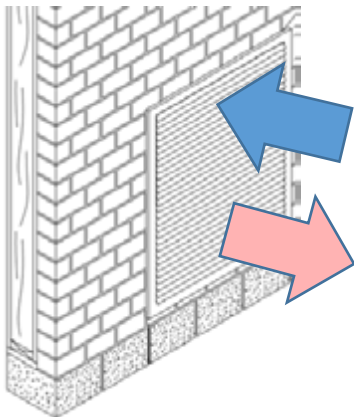

I-TEC and Q-TEC Units:

These units draw the cool outdoor air through the top section of the wall louver and exhaust the warmer condenser air out of the lower section of the louver. I-TEC units also draw a small amount of air through the outer right and left side of the louver.

Unit Operation

Air-to-Air Cooling Products (Air Conditioners)

The cooling mode operates similar to a refrigerator, removing heat from inside the conditioned space and rejecting it outside of the space being controlled. There are three main parts of the system:

1. The evaporator (indoor) coil where cold refrigerant absorbs heat from the air, which circulates from the conditioned space through the machine and is returned to the space at a lower temperature and with some of the humidity (moisture) removed. The moisture exits through a condensate drain system. A motor/blower assembly moves the indoor air through the system.
2. The compressor, which is a sealed pump that moves the refrigerant through the system.
3. The condenser (outdoor) coil where the heat that was absorbed from the indoor space is discharged to the outdoor environment. A motor/fan system moves the outdoor air across the condenser coil. A properly sized air conditioner cannot cool a structure off rapidly and instead will pull down the temperature slowly. It also will remove a certain amount of moisture (humidity) from the circulating airstream in the process. It may take several hours to pull down a hot, moist building or structure on initial startup or anytime the system has been turned off for a long period of time. It is generally best to set the thermostat at a comfortable temperature and let it control the system as needed, rather than turning it on and off.

Moisture (humidity) removal with a conventional air conditioner (cooling) unit, or heat pump when operating in the cooling mode, is not directly controlled and is a by-product of the unit operating to control temperature in response to the temperature (thermostat) control device. **Oversized equipment can easily control temperature but will have short run-times, thus reducing its ability to remove moisture from the circulating air stream.**

There are also many additional influences that can affect humidity levels within the conditioned space such as laundry appliances, cooking, showers, exhaust fans and any other items that can generate moisture or affect its removal from the space. Therefore, while operation of the air conditioning or heat pump system in the cooling mode will remove some amount of moisture as it reduces the air temperature, precise humidity regulation in the conditioned space cannot be assured and additional equipment such as a dedicated dehumidifier may be required.

Air-to-Air Cooling and Heating Products (Heat Pumps)

A heat pump is a refrigerant-based system that has additional components and controls that both heats and cools using a compressor for both modes of operation. Most heat pumps will also be equipped with some amount of electric heat to supplement the heating capacity of the compressor system on an as-needed basis. This operation is entirely automatic and is controlled by the indoor thermostat and possibly also an outdoor thermostat.

Cooling Mode

The cooling mode of a heat pump is exactly the same as that described for an air conditioner in the above section.

Heating Mode

The system operates in reverse cycle, meaning that it absorbs and moves heat from the outdoors and transfers it indoors to be rejected into the circulating air stream. Even though it seems cold to humans, there is usable heat that can be extracted efficiently from the outdoor air down to 0°F, although the colder the air is there is less heat to extract and the operating efficiency is diminished.

Defrost Cycle

When operating in the heating mode, the outdoor coil will be colder than the outdoor air that is forced over it by the fan system. When the outdoor air temperature is above approximately 40°F, moisture can accumulate on the coil and it will drain down and out the base of the unit. As the air temperature gets below approximately 40°F, the coil temperature will start to drop below 32°F, and frost or ice will begin to form on the coil.

An automatic defrost system keeps track of system run time when the outdoor coil temperature is in the freezing zone and will initiate a defrost cycle at the appropriate time. The unit continues to operate during the defrost cycle, but the outdoor fan motor will stop and the reversing valve will shift positions to flow hot refrigerant gas through the outdoor coil to melt the accumulated frost. Water will start to drain freely from the unit, and steam may be emitted from the unit.

The length of the defrost cycle will vary depending upon actual outdoor temperature, humidity levels and amount of accumulated frost. It could range from 1-2 minutes up to but not exceeding 8 minutes. When the defrost cycle

terminates, the reversing valve will shift back to heating mode and the outdoor fan will restart. There is typically a large puff of steam emitted as the fan restarts. When the heat pump shifts from cool to heating mode, from heating to cooling mode and especially during defrost cycles, there will be a pressure transfer sound heard as the reversing valve redirects the flow of refrigerant. This is commonly described as a hissing noise and is a normal sound for this type equipment.

For air source heat pumps, it is important to keep heavy snow from accumulating around the machine to the point of blocking the inlet and outlet openings to the outdoor coil section. For wall mounted or other equipment that is elevated, this should not be a factor; but for equipment installed on or near the ground, this can be an issue in areas prone to heavy and/or blowing snow. The air source heat pump cannot operate effectively and efficiently when snowbound just as a car cannot function well in heavy snow conditions.

Water-to-Air Cooling and Heating Products (Geothermal Heat Pumps)

These types of heat pumps are also commonly referred to as water source or geothermal systems. Just like the air source heat pump, they are refrigerant-based systems that both heat and cool using a compressor for both modes of operation. The primary difference is that the system uses water or antifreeze-protected water solution instead of an air-cooled outdoor heat transfer coil, and there is no outdoor motor/fan system but instead a water pump to provide adequate water flow to the system.

Cooling Mode

The cooling mode of a water-to-air heat pump is exactly the same as that described for an air conditioner in the previous Air Conditioner section, except that the outdoor coil uses water instead of air for the heat transfer medium.

Heat Mode

The system operates in reverse cycle, meaning that it acquires and moves heat from the water supply flowing through the water to refrigerant coil and transfers it indoors to be rejected into the circulating air stream.

Most water-to-air heat pumps (but not all) will also be equipped with some amount of electric heat to supplement the heating capacity of the compressor system on an as-needed basis. This operation is entirely automatic and is controlled by the indoor thermostat.

Because of the design of water-to-air heat pumps and the water temperatures involved, no defrost system is required as in air-to-air heat pumps.

Water Supply Systems

Depending upon the type and application of the water-to-air heat pump, the water side of the system could be one of the following:

1. Individual closed loop buried in a trench or vertical bore hole(s).
2. Individual loop submerged in a pond.
3. Water supplied from a well and discharged into pond, stream, ditch or another well.
4. Water supplied from a boiler/tower system, typically only in larger multi-unit installations.

Dehumidification and Ventilation Operation

Dehumidification (Air-to-Air or Water-to-Air Systems)

Many Bard systems, typically those used in schools or other commercial applications, have a dedicated dehumidification capability by having a special additional refrigeration circuit (factory-installed option only) in addition to the basic system. These special systems, sometimes also referred to as hot gas reheat, are designed to control humidity on demand from a humidity controller much the same as the basic cooling and/or heating system is controlled by a wall thermostat. Consult your installer and/or service company to determine if your installation has any of these devices and for any instructions or maintenance requirements you should be aware of as the user.

Ventilation Options (Air-to-Air or Water-to-Air Systems)

All Bard systems are available with factory-installed vent options. Most units can have ventilation field installed after unit installation.

Ventilation has multiple purposes:

- Outside air intake for occupied structures
- Positive pressurization
- Energy savings when outdoor air can be used for cooling
- Agricultural use of bringing in outdoor air and exhausting room air
- Equipment and electronics ventilation

Review product specifications and manuals for more details regarding available ventilation options and features. Product documentation is shipped with the product and also available at www.bardhvac.com.

All Units – Troubleshooting

Your Bard product is made to operate for many trouble-free years if installed properly and maintenance practices are followed. Be sure to verify that all filters are clean, and condenser coils are free of dirt and debris. Often these items may look clean at first, but upon closer inspection, show signs of dirt and debris build-up. New units on new structures may have dirt and dust in filters from the building construction process.

Thermostats and unit controllers often contain vent holes for proper sensor measurement inside the device. Make sure the thermostat or controller are not full of dirt and dust from building construction or years of use.

Verify all requirements in the installation instructions and specification sheets are met. Unit voltages, airflow clearance requirements and clean unit power without brownouts or spikes play a critical role in unit performance. If 208 VAC power is supplied to the unit, the 208V tap must be used on the 24 VAC transformer located inside the control panel. Common sense must also be used when installing the unit in an environment that may put the unit at risk of improper operation.

Helpful Hints and Good Operating Practices

The following information will help you enjoy the full comfort and benefits of your Bard cooling and heating system, maximize the performance and efficiency and help extend the life of your system.

1. Always keep the equipment in peak operating condition with routine scheduled maintenance, especially for the air filters, and to assure a clean outdoor coil.
2. For most efficient operation, set the thermostat at the temperature you prefer and then let it take control. If any changes to the settings are required, they should be made in small adjustments and the system be allowed time to respond. Rapid changes either up or down should not be done.
3. Setting the thermostat very high does not make the system heat faster and setting it very low does not make it cool faster.
4. It is not recommended to turn the system "Off" then back "On" when you need it. This can allow temperature and humidity to build up in warm weather conditions and force the system to run continuously to try and catch up. If the building is to be unoccupied for a lengthy period, it is best to adjust the thermostat to a reasonable higher (or lower—depending on the season) setting rather than turning it completely off. Upon return, the inside conditions will not be totally out of control and recovery time to desired conditions would be much shorter.
5. Airflow inside the room or building is very important. Keep all supply registers open and all returns free and unrestricted. Avoid placing objects in areas that will hinder unit airflow. The heating and cooling system is designed to have a certain amount of airflow for proper operation. Therefore, closing off registers, in unused rooms as an example, could reduce airflow below acceptable levels and should not be done without review by your service company who can assess the overall situation and advise you accordingly.
6. Heat pumps, especially air-to-air heat pumps, may have the system (compressor) run continuously at lower outdoor temperatures, and this is normal. The heat pump (compressor) mode is controlled by the beginning stages of the thermostat and delivers the most efficient heat. As the outdoor temperature drops off, the heat pump mode heat will also diminish (because there is less heat in the outdoor air to absorb) and must be supplemented by additional electric heat stages, which are not as efficient as the heat pump. The thermostat automatically controls everything and the backup heat will only operate on demand as needed to maintain the desired temperature.
7. The thermostat or controller is the user's primary connection to the system so it is very important to have a thorough understanding of how it works and how to use it properly. Have your installer or service company explain and demonstrate proper operation of the controls.
8. Make sure you thoroughly understand how the heating and cooling system itself is intended to operate and what to expect from it. Have your installer or service company explain and demonstrate proper operation of the heating and cooling system.

SERVICING PROCEDURE

R-410A LEAK TEST EVACUATION CHARGING

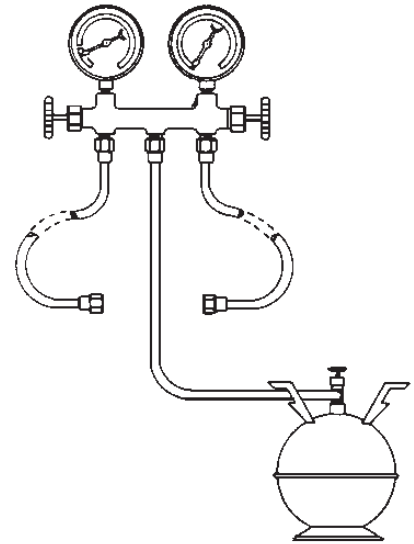

Climate Control Solutions

Bard Manufacturing Company, Inc.
Bryan, Ohio 43506
Since 1914...Moving ahead, just as planned.

Manual No.: 2100-479
Supersedes: NEW
File: Volume I, Tab 1
Date: 03-08-07

CONTENTS

General

Recovery Equipment Rated for R-410A.....	3
Leak Detectors.....	3
Gauge Manifold.....	3
Attaching Gauge Manifold.....	3
Attaching Manifold Hose to Schrader Valve.....	4
Leak Test.....	4
Evacuation	4 & 5
Charging	5
Preliminary Charging Steps	5
Charging the System by Weight	5

Troubleshooting the Mechanical System

Air Conditioning & Heat Pump - Cooling	9
Low Suction—Low Head Pressure	9
High Suction—Low Head Pressure	9
Low Suction—High Head Pressure	9
High Suction—High Head Pressure.....	9
Heat Pump - Heating	9
Low Suction—Low Head Pressure	9
High Suction—Low Head Pressure	9
Low Suction—High Head Pressure	9
High Suction—High Head Pressure.....	9

Figures

Figure 1: Typical AC System Cooling Cycle.....	6
Figure 2: Typical HP System Cooling Cycle	7
Figure 3: Heating Cycle	8

Charts

Troubleshooting Chart for Air Conditioners.....	10
Troubleshooting Chart for Air-to-Air Heat Pumps....	11

GENERAL



WARNING

The oils used with R-410A refrigerant are hygroscopic and absorb water from the atmosphere readily. Do not leave systems open to the atmosphere for more than 5 minutes. If the system has been open for more than 5 minutes, change the filter dryer immediately before evacuation. Then recharge the system to the factory specified charge.

Recovery equipment rated for R-410A refrigerant

R-410A has an ozone depletion potential of zero, but must be reclaimed due to its global warming potential.

The gauge manifold set is specially designed to withstand the higher pressure associated with R-410A. Manifold sets are required to range up to 800 psig on the high side and 250 psig on the low side with a 250 psig low side retard.

All hoses must have a service rating of 800 psig. (This information will be indicated on the hoses.)

Vacuum Pump and micron gauge must be used when evacuating a system to 500 microns.

Leak Detectors

An electronic leak detector capable of detecting HFC refrigerant can be used with R-410A refrigerant.

GAUGE MANIFOLD



WARNING

Gauge manifold must be suitable for use with R-410A refrigerant and POE oils.

A necessary instrument in checking and serving air conditioning and heat pump equipment is the gauge manifold. Its purpose is to determine the operating refrigerant pressures in order for the serviceman to analyze the condition of the system.

The valving on the manifold is so arranged that when the valves are closed (front-seated) the center port on the manifold is closed to the gauges and gauge ports. With the valves in the closed position, the gauge ports are still open to the gauges, permitting the gauges to register system pressures. Opening either valve opens the center port to that side of the manifold and system.

ATTACHING GAUGE MANIFOLD

For leak testing, purging, checking charge, charging liquid or evacuating, connect high pressure side of gauge manifold to Schrader valve on liquid or discharge line. Connect suction side of gauge manifold to Schrader valve on suction line. On heat pumps the suction line is between compressor and reversing valve.

ATTACHING MANIFOLD HOSE TO SCHRADER VALVE



WARNING

As a safety measure, it is wise to detach refrigerant hoses at the lowest pressure readings on the system. To do this:

- A. Put high pressure hose "B" on first. (Unit should not be running.)
- B. Put low pressure hose "A" on second. (Unit should be running.)

1. Remove cap from valve.
2. Make sure gauge manifold valves are closed.
3. If hose does not have an unseating pin, a number 395 Superior or equivalent unseating coupler must be used.
4. Make sure coupler is lined up straight with Schrader valve. Screw coupler on to valve.
5. Open gauge manifold valve slightly and purge air from hose with refrigerant.
6. Read the suction pressure on compound gauge and heat pressure on pressure gauge.
7. To remove, push end of hose tight against end of Schrader valve and hold in place while quickly unscrewing coupler nut from Schrader valve.
8. Remove coupler from Schrader valve. Replace caps on valve.

Leak Test

1. Remove gauge port cap from suction and liquid service valve ports and attach manifold gauge hoses. Connect an upright R-410A drum to center port of gauge manifold. Open refrigerant drum valve and manifold high pressure gauge valve to pressurize system to a positive pressure with refrigerant vapor. Pressurize the complete system with dry nitrogen, or CO₂ until the pressure reaches 200 psig. **Do not** exceed 250 psig.
2. Close manifold high pressure gauge valve. Check all soldered joints, including those on the evaporator coil with an Electronic Leak Detector suitable for use with HFC refrigerants or R-410A. If a leak is found which requires soldering, pressure in the system must be bled off since it is impossible to solder with unit pressurized. Be sure all leaks are located and marked before bleeding pressure from system.

3. Close drum valve and disconnect from center port. Release nitrogen or CO₂ into the atmosphere through suction line of gauge manifold.
4. Correct any leaks and recheck. When leaks, if any, have been repaired, system is ready to be evacuated and charged. Relieve all pressure from the system down to 0 psig.
5. Change the filter dryer. When leaks, if any, have been repaired, system is ready to be evacuated and charged. Relieve all pressure from the system down to 0 psig.

EVACUATION

Evacuation

An evacuation to 500 microns is usually sufficient to remove moisture from a system using R-22 and mineral oil lubricant. A 500 micron evacuation, however, will not separate moisture from Polyol Ester oil (POE) in R-410A systems.

In addition to a 500 micron evacuation, the liquid line filter dryer (R-410A compatible) must be replaced any time the system is open. When removing a filter dryer from a system, do not use a torch; use a tubing cutter to avoid releasing moisture back into the system.

Older R-22 leak detectors, as well as halide torch leak detectors, will not detect leaks in R-410A systems. Never use air and R-410A to leak check, as the mixture may become flammable at pressures above 1 atmosphere. A system can be safely leak-checked by using nitrogen or a trace gas of R-410A and nitrogen.

Remember: *Always use a pressure regulator with nitrogen and a safety valve down stream - set at no more than 150 psig.*

1. Evacuate system to less than 500 microns, using a good vacuum pump and an accurate high vacuum gauge. Operate the pump below 500 microns for 60 minutes and then close valve to the vacuum pump. Allow the system to stand for 30 additional minutes to be sure a 500 micron vacuum or less is maintained.



WARNING

At no time use the compressor to evacuate the system or any part of it.

2. Disconnect charging line at vacuum pump and connect to refrigerant supply. Crack the cylinder valve and purge charging line at center on manifold. Then close cylinder valve.
3. The system is now ready for the correct operating charge of Refrigerant R-410A.

R-410A System Charging

Even though R-410A has a very small fractionation potential, it cannot be ignored completely when charging. To avoid fractionation, charging of an air conditioner or heat pump system incorporating R-410A **shall be done with “liquid”** to maintain optimum system performance. To insure that the proper blend composition is charged into the system, it is important that liquid only be removed from the charging cylinder. Some cylinders supplied by manufacturers have dip tubes, which allow liquid refrigerant to be removed from the cylinder when it is in the upright position. Cylinders without dip tubes have to be tipped upside down in order for liquid to be removed. The Service Technician must differentiate between which type of charging cylinder they are using to avoid removing vapor refrigerant instead of liquid refrigerant to avoid fractionation and for safety concerns.

Connect the gauge manifold to the high and low side. Allow liquid to enter the high side only. The high side will hold 80-100% of the total charge. When liquid stops flowing, close high side port. The remainder of the charge will be added to the low side. Keep in mind two issues: first, never start the compressor with less than 55 psig of suction pressure. Secondly, make sure the liquid is throttled, thus vaporized into the low side of the system to avoid compressor damage. A throttling valve can be used to insure that liquid is converted to vapor prior to entering the system. Proper manipulation (restricting) of the manifold gauge set can also act as a throttling device to insure liquid is not entering the compressor.

CHARGING

1. **Single Package Units**—Refer to the unit serial plate for the full operating charge.

PRELIMINARY CHARGING STEPS

If the system has been open to the atmosphere, the filter dryer should be replaced and then evacuated. Then proceed as follows:

1. Attach a drum of proper, clean refrigerant to the center port of the charging manifold with one of the charging hoses.
2. Attach a second charging hose to the suction gauge (low pressure) side of the gauge manifold.
3. Remove the cap from the suction line valve.
4. Loosely attach the suction gauge hose to the line valve. Open the valve on the refrigerant drum and the suction valve on the charging manifold slightly to purge the air from the manifold and hoses before tightening the fitting.
5. Attach the third hose to the high pressure side of the manifold and the liquid line valve. Repeat steps 3 and 4 above.

CHARGING THE SYSTEM BY WEIGHT

1. Connect manifold as instructed.
2. Place refrigerant drum upright on scale and determine exact weight of the refrigerant and cylinder.
3. With manifold suction valve closed and manifold discharge valve open, open refrigerant cylinder liquid valve and allow pressure in system to balance with pressure of cylinder or 80% of charge is in the unit - whichever comes first.
4. When there is approximately an 80% charge, front seat (close) the discharge manifold valve and let the system stabilize for about five minutes.
5. Start compressor by setting thermostat.
6. Finish charging with liquid by cracking the suction valve. Open the manifold low pressure valve to allow refrigerant to flow into the system. Throttle the manifold valve to keep pressure about 100 psig for R-410A.
7. When the correct weight of refrigerant has been added to the unit, close refrigerant cylinder valve and allow unit to run for 30 minutes. Refer to Start-Up Procedure and Check List for further start-up details.
8. Front seat gauge manifold valves, disconnect charging and gauge hoses and replace all valve caps.

**FIGURE 1
TYPICAL AIR CONDITIONING SYSTEM COOLING CYCLE**

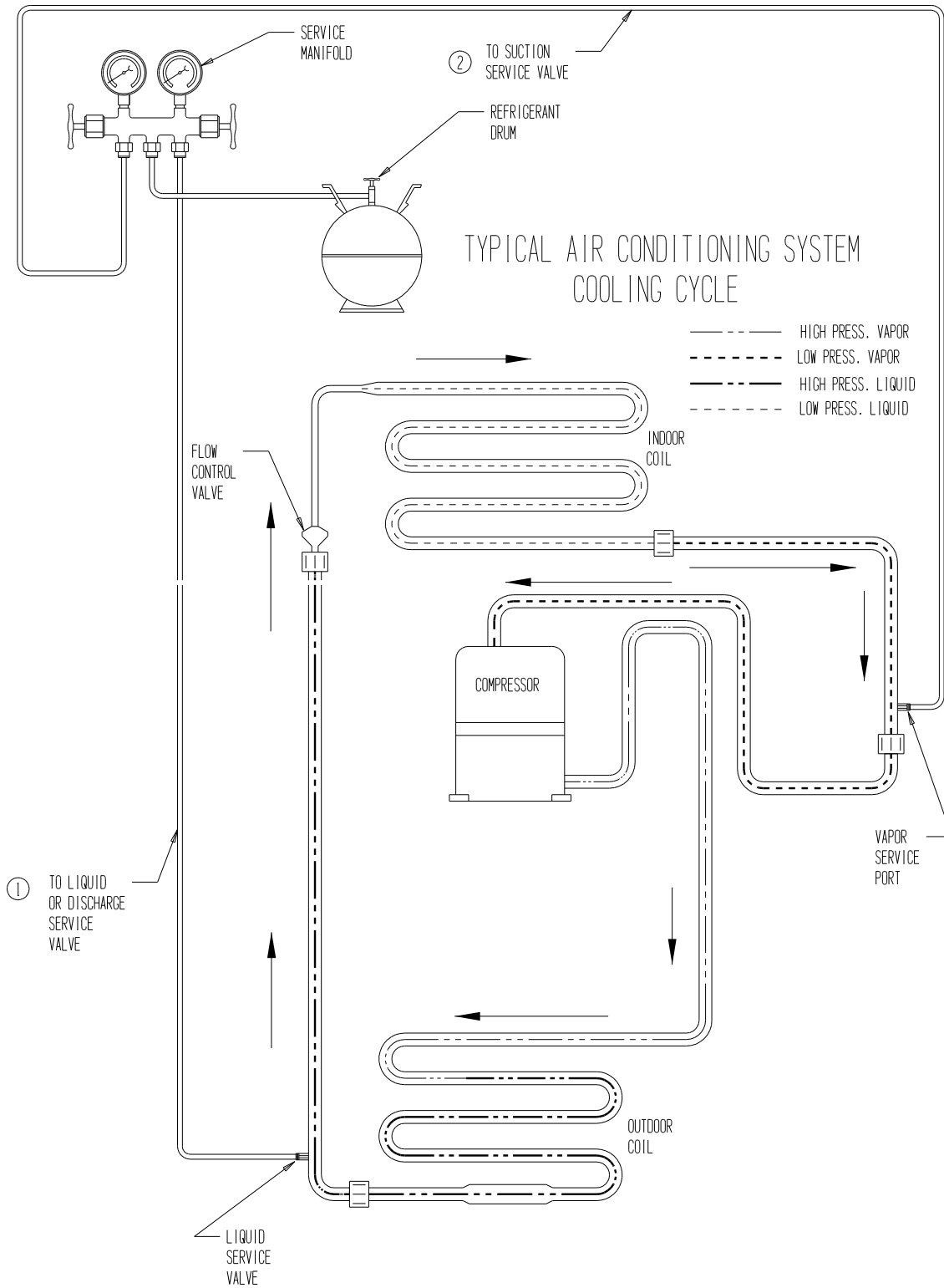

MIS-369

FIGURE 2
TYPICAL HEAT PUMP SYSTEM COOLING CYCLE

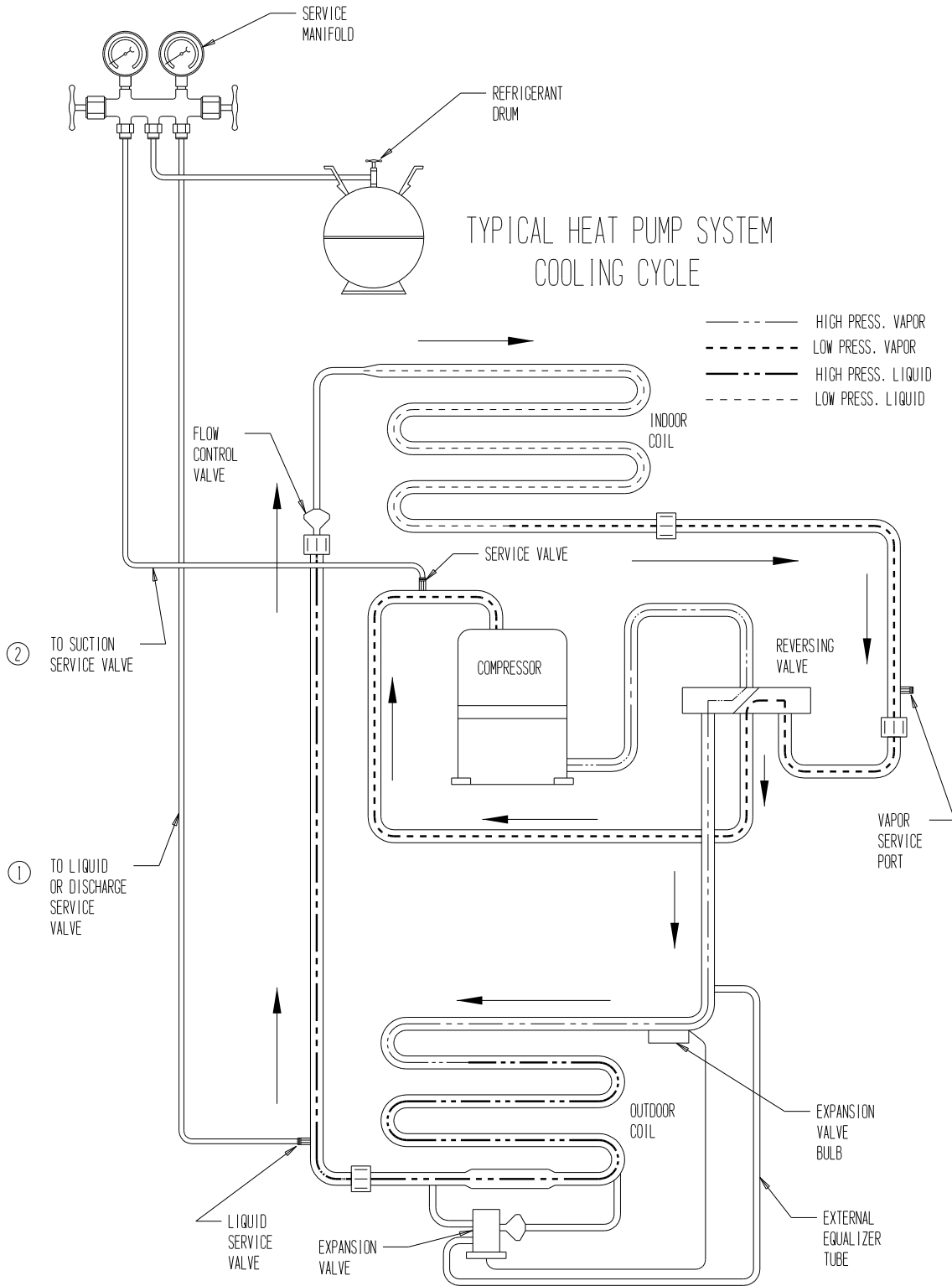

MIS-368

WARNING

To speed refrigerant flow, it may be necessary to place refrigerant drum in a pan of warm water (not greater than 130°F). Remember to either consider the total weight of the pan of water or remove the drum for weighing frequently to keep track of the charging process.

**FIGURE 3
HEATING CYCLE**

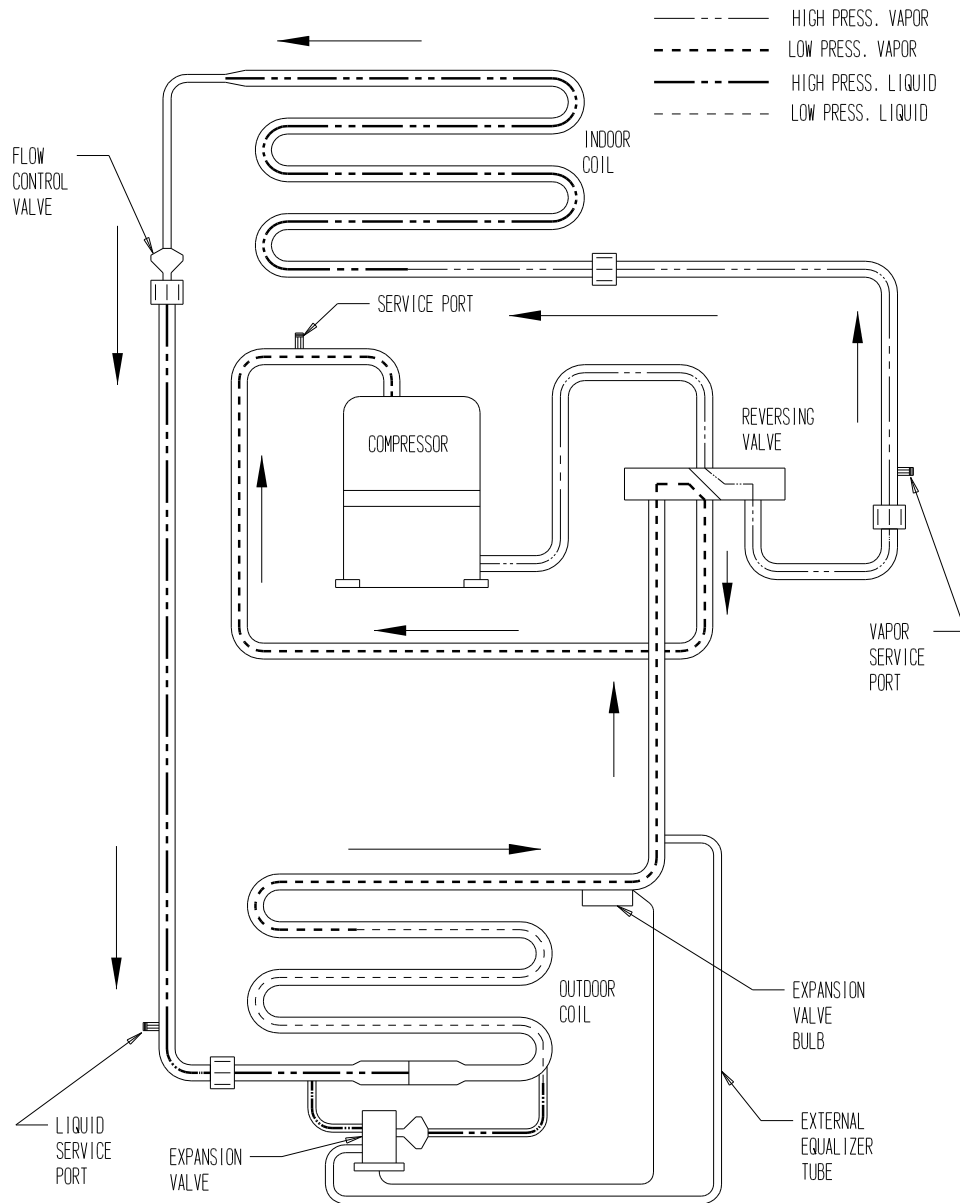

MIS-289

TROUBLESHOOTING THE MECHANICAL SYSTEM

AIR CONDITIONING AND HEAT PUMP — COOLING

LOW SUCTION—LOW HEAD PRESSURE

1. Restricted airflow over indoor coil.
2. Defective indoor fan motor.
3. Low indoor temperature
4. Iced indoor coil.
5. Restricted liquid line, dryer, metering device, etc.
6. Low charge.
7. Low ambient entering air temperature. (Low entering water temperature to water coil.Ⓢ)

HIGH SUCTION—LOW HEAD PRESSURE

1. Defective or broken valves.
2. IPRV valve open.
3. Defective reversing valve.

LOW SUCTION—HIGH HEAD PRESSURE

1. Partial restriction and then overcharged.

HIGH SUCTION—HIGH HEAD PRESSURE

1. High entering outdoor air temperature. (High entering water temperature.Ⓢ)
2. Low airflow outdoor coil. (Low water flow.Ⓢ)
3. Overcharged.
4. Air in system.
5. Restricted outdoor coil. (Restricted water coil.Ⓢ)
6. High indoor air temperature.

Ⓢ Water source heat pump.

HEAT PUMP — HEATING

LOW SUCTION—LOW HEAD PRESSURE

1. Restricted airflow through outdoor coil. (Restricted water flow through water coil.Ⓢ)
2. Defective outdoor motor. (Defective water pump.Ⓢ)
3. Low outdoor air temperature. (Low water temperature.Ⓢ)
4. Frozen outdoor coil. (Frozen water coil.Ⓢ)
5. Restricted liquid line, dryer, metering device, etc.
6. Low charge.
7. Low indoor air temperature.

HIGH SUCTION—LOW HEAD PRESSURE

1. Defective or broken valves.
2. IPR valve open.
3. Defective reversing valve.

LOW SUCTION—HIGH HEAD PRESSURE

1. Partial restriction and then overcharged.

HIGH SUCTION—HIGH HEAD PRESSURE

1. High entering outdoor air temperature. (High entering water temperature.Ⓢ)
2. Low indoor airflow.
3. Overcharged.
4. Air in system.
5. Restricted air coil.
6. High indoor air temperature.

Ⓢ Water source heat pump.

INSTALLATION INSTRUCTIONS

Wall Mounted Package Heat Pump

Models:

W18HY-A	W24HY-A	W30HY-A	W36HY-A
	W24HY-B	W30HY-B	W36HY-B
	W24HY-C	W30HY-C	W36HY-C
	W24HYDA	W30HYDA	W36HYDA
	W24HYDB	W30HYDB	W36HYDB
	W24HYDC	W30HYDC	W36HYDC



Bard Manufacturing Company, Inc.
Bryan, Ohio 43506
www.bardhvac.com

Manual: 2100-790A
Supersedes: 2100-790
Date: 8-14-23

CONTENTS

Safety Instructions	4	Start Up	27
General Information	10	General	27
Heat Pump Wall Mount Model Nomenclature	10	Topping Off System Charge.....	27
Shipping Damage.....	10	Safety Practices	27
General	10	Important Installer Note.....	27
Duct Work	10	High and Low Pressure Switch.....	28
Filters	11	Three Phase Scroll Compressor Start Up	
Fresh Air Intake	11	Information.....	28
Installation	13	Phase Monitor	28
Basic Installation Design and Application Planning	13	Condenser Fan Operation	28
Wall Construction	13	Sequence of Operation.....	28
Outdoor Area Inspection.....	13	Cooling	28
Condensate Water Drainage	13	Heating	28
Indoor Ducted and Non-Ducted Applications.....	13	Dehumidification and Electronic Expansion	
Indoor Supply Airflow.....	13	Valve (EEV).....	28
Indoor Return Airflow.....	14	Balanced Climate Mode	28
Ducted Applications	14	Defrost Cycle.....	29
Free Blow Applications.....	14	Low Pressure Switch Bypass Operation	29
Thermostat or Indoor Temperature Sensor		High Pressure Switch Operation.....	30
Placement	14	Vent Connection Plug.....	30
Unit Installation	15	Pressure Service Ports	30
Materials/Tool List	15	Service Hints	30
Wall Preparation.....	15	Service	32
Wall Mount Installation to Wall Surface	15	Solid State Heat Pump Control Troubleshooting	
Wiring – Main Power.....	22	Procedure	32
Wiring – Low Voltage.....	22	Checking Temperature Sensor Outside	
Low Voltage Connections.....	22	Unit Circuit.....	33
Unit Shutdown Feature	22	Troubleshooting Nidec SelecTech Series ECM	
Balanced Climate™ Feature.....	22	Motors.....	34
Dehumidification Feature	23	If the Motor Is Running.....	34
Ventilation Features	23	If the Motor Is Not Running.....	34
Low Ambient Control (LAC)	23	Model SelecTech Communication Diagnostics ...	35
Outdoor Temperature Switch and Freeze		Fan Blade Setting Dimensions	36
Protection Thermostat	23	Removal of Fan Shroud.....	36
Alarm Relay Feature	23	R-410A Refrigerant Charge	36
Dirty Filter Switch Indicator (DFS).....	23	Setting Unit Airflow	40
		Blower Speeds	40
		Speed Tap 1 – Vent/Blower Only	41
		Speed Tap 2 – Balanced Climate	41
		Speed Tap 3 – Default LO Cooling &	
		Heating	41
		Speed Tap 4 – Optional MED Cooling &	
		Heating	41
		Speed Tap 5 – Optional HI Cooling &	
		Heating	41
		Dirty Filter Switch	42
		Dirty Filter Switch Adjustment	42

TABLES

Table 1	Clearance Required for Service Access and Adequate Condenser Airflow.....	16
Table 2	Minimum Clearances Required to Combustible Materials.....	16
Table 3	Low Voltage Connections	23
Table 4	Wall Thermostats	24
Table 5	Humidity Controls	24
Table 6	CO ₂ Controller.....	24
Table 7	Thermostat Wire Size.....	24
Table 8	Troubleshooting	32
Table 9	Temperature vs. Resistance.....	33
Table 10	Fan Blade Dimension	36
Table 11A	Cooling Pressure	37
Table 11B	Heating Pressure.....	37
Table 12	Cooling Pressure – Balanced Climate Airflow	38
Table 13	Electrical Specifications	39
Table 14	Recommended Airflow.....	40
Table 15	Blower Speeds for Unit Operational Modes.....	41
Table 16	Indoor Blower Performance	44
Table 17	Maximum ESP of Operation – Electric Heat Only	45
Table 18	Electric Heat	45
Table 19	Optional Accessories	46
Table 20	Vent and Control Options	47

FIGURES

Figure 1	Fresh Air Damper.....	12
Figure 2	Unit Dimensions	16
Figure 3A	Mounting Instructions – W18H, W24H..	17
Figure 3B	Mounting Instructions – W30H, W36H..	18
Figure 4	Electric Heat Clearance – All Models.....	19
Figure 5	Wall Mounting Instructions	20
Figure 6	Wall Mounting Instructions	20
Figure 7	Common Wall Mounting Installations	21
Figure 8	Thermostat Connections	25
Figure 9	Thermostat Connections	26
Figure 10	Defrost Control Board	31
Figure 11	Motor Connections	34
Figure 12	Motor Connections	35
Figure 13	Fan Blade Setting	36
Figure 14	Speed Taps.....	40
Figure 15	Speed Taps.....	40
Figure 16	Dirty Filter Switch Location.....	42
Figure 17	Adjusting Dirty Filter Switch.....	43

GRAPHS

Graph 1	W18HY FAD-NE2, 3 W/O Exhaust Ventilation Delivery	48
Graph 2	W24HY FAD-NE2, 3 W/O Exhaust Ventilation Delivery	48
Graph 3	W30HY FAD-NE2, 3 W/O Exhaust Ventilation Delivery	49
Graph 4	W36HY FAD-NE2, 3 W/O Exhaust Ventilation Delivery	49

NOTICE

APPLIANCE ACCESSIBLE TO THE GENERAL PUBLIC.

SAFETY INSTRUCTIONS

READ ALL INSTRUCTIONS BEFORE USE

Your safety and the safety of others are very important.

We have provided many important safety messages in this manual and on your appliance. Always read and follow all safety messages.

ANSI Z535.5 Definitions:

DANGER: Indicate[s] a hazardous situation which, if not avoided, will result in death or serious injury. The signal word "DANGER" is to be limited to the most extreme situations. DANGER [signs] should not be used for property damage hazards unless personal injury risk appropriate to these levels is also involved.

WARNING: Indicate[s] a hazardous situation which, if not avoided, could result in death or serious injury. WARNING [signs] should not be used for property damage hazards unless personal injury risk appropriate to this level is also involved.

CAUTION: Indicate[s] a hazardous situation which, if not avoided, could result in minor or moderate injury. CAUTION [signs] without a safety alert symbol may be used to alert against unsafe practices that can result in property damage only.

NOTICE: [this header is] preferred to address practices not related to personal injury. The safety alert symbol shall not be used with this signal word. As an alternative to "NOTICE" the word "CAUTION" without the safety alert symbol may be used to indicate a message not related to personal injury.

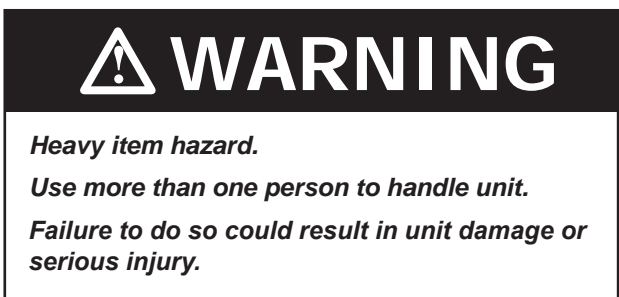
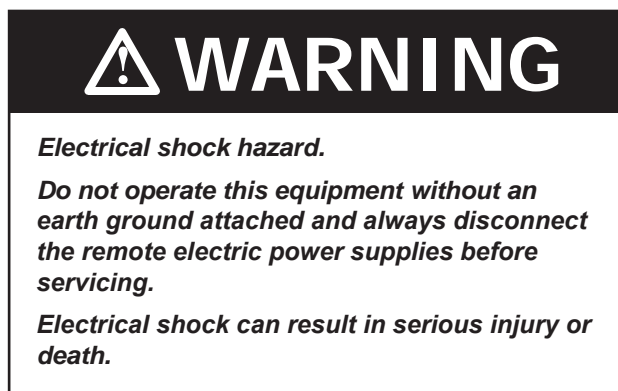
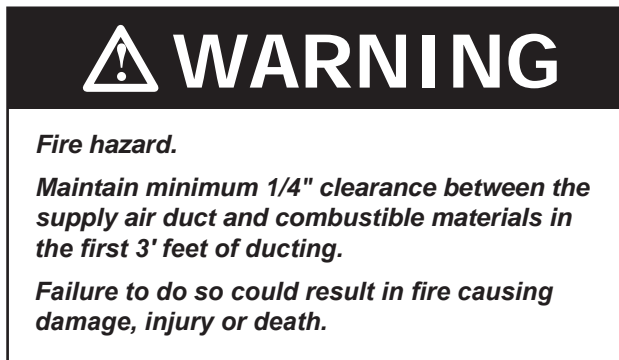

WARNING

Electrical shock hazard.

Have a properly trained individual perform these tasks.

Failure to do so could result in electric shock or death.

CAUTION

Sharp metallic edges.

Take care and wear appropriate protective devices to avoid accidental contact with sharp edges.

Failure to do so can result in personal injury.

The following symbols are displayed on units.



This symbol indicates that the Operation Manual should be read carefully.

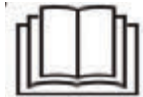

This symbol indicates that a service personnel should be handling this equipment with reference to the Installation Manual.



This symbol indicates that information is available such as the Operation Manual or Installation Manual.

IMPORTANT SAFETY INSTRUCTIONS



WARNING

To reduce the risk of explosion, fire, death, electric shock, scalding or injury to persons when using this product, follow basic precautions, including the following:

GENERAL

- The equipment covered in this manual is to be installed by trained, experienced service and installation technicians.
- This appliance is not intended for use by persons (including children) with reduced physical, sensory or mental capabilities, or lack of experience and knowledge, unless they have been given supervision or instruction concerning use of the appliance by a person responsible for their safety.
- The refrigerant system is completely assembled and charged. All internal wiring is complete.
- The unit is designed for use with or without duct work. Flanges are provided for attaching the supply and return ducts.
- These instructions explain the recommended method to install the air-cooled self-contained unit and the electrical wiring connections to the unit.
- These instructions and any instructions packaged with any separate equipment required to make up the entire air conditioning system should be carefully read before beginning the installation. Note particularly "Starting Procedure" and any tags and/or labels attached to the equipment.
- While these instructions are intended as a general recommended guide, they do not supersede any national and/or local codes in any way. Authorities having jurisdiction should be consulted before the installation is made. See Additional Publications for information on codes and standards.
- Size of unit for a proposed installation should be based on heat loss calculation made according to methods of Air Conditioning Contractors of America (ACCA). The air duct should be installed in accordance with the Standards of the National Fire Protection Association for the Installation of Air Conditioning and Ventilating Systems of Other Than Residence Type, NFPA No. 90A, and Residence Type Warm Air Heating and Air Conditioning Systems, NFPA No. 90B. Where local regulations are at a variance with instructions, installer should adhere to local codes.

INSTALLATION

- This product is not intended for use at altitudes exceeding 2,000 meters (6,561 feet). For appliances intended for use at altitudes exceeding 2 000 m (6,561 feet), the maximum altitude of use shall be stated.
- Before use, the appliance must be properly installed as described in this manual.
- Contact the authorized service technician for repair or maintenance of this unit.
- Contact the installer for installation of this unit.
- The air conditioner is not intended for use by young children or invalids without supervision.
- Young children should be supervised to ensure that they do not play with the air conditioner.
- Installation work must be performed in accordance with the National Electric Code by qualified and authorized personnel only.
- Connect to a properly rated, protected, and sized power circuit to avoid electrical overload.
- Adhere to all industry recommended safety procedures including the use of long-sleeved gloves and safety glasses.
- Use care when unpacking and installing. The edges of the product may be sharp.
- Keep packaging materials out of the reach of children. These materials can pose a suffocation risk to children.

OPERATION

- This appliance is not intended for use by persons (including children) with reduced physical, sensory, or mental capabilities, or lack of experience and knowledge, unless they have been given supervision or instruction concerning use of the appliance by a person responsible for their safety.
- Use this appliance only for its intended purpose.
- Never attempt to operate this appliance if it is damaged, malfunctioning, partially disassembled, or has missing or broken parts.
- Do not tamper with controls.

INSTRUCTIONS DE SÉCURITÉ

LIRE TOUTES LES INSTRUCTIONS AVANT UTILISATION

Votre sécurité et celle des autres sont très importantes.

Nous avons fourni de nombreux messages de sécurité importants dans ce manuel et sur votre appareil. Lisez et suivez toujours tous les messages de sécurité.

Définitions ANSI Z535.5 :

DANGER : Indique une situation dangereuse qui, si elle n'est pas évitée, entraînera certainement la mort ou des blessures graves. Le mot « DANGER » doit être limité aux situations extrêmes. Les indications « DANGER » ne doivent pas être utilisées pour les risques de dégâts matériels, à moins qu'il n'existe un risque concomitant de blessures corporelles.

AVERTISSEMENT : Indique une situation dangereuse qui, si elle n'est pas évitée, peut entraîner la mort ou des blessures graves. Les indications « AVERTISSEMENT » ne doivent pas être utilisées pour les risques de dégâts matériels, à moins qu'il n'existe un risque concomitant de blessures corporelles.

ATTENTION : Indique une situation dangereuse qui, si elle n'est pas évitée, peut entraîner des blessures mineures à modérées. Les indications « ATTENTION », sans symbole d'avertissement, peuvent être utilisées pour alerter sur des pratiques dangereuses pouvant entraîner des dégâts matériels uniquement.

REMARQUE : cet avis concerne les pratiques n'entraînant aucune blessure corporelle. Le symbole d'avertissement ne doit pas être utilisé avec ce mot. Comme alternative à « AVIS », le mot « ATTENTION » sans symbole d'avertissement peut être utilisé pour indiquer un message non lié à des blessures corporelles.



 **AVERTISSEMENT**

Risque de choc électrique.

Ne pas faire fonctionner cet équipement sans qu'il soit relié à la terre et toujours débrancher les alimentations électriques avant de procéder aux opérations d'entretien.

Une électrisation peut entraîner des blessures graves ou la mort.

REMARQUE

APPAREIL ACCESSIBLE AU GRAND PUBLIC.

 **AVERTISSEMENT**

Risque d'incendie.

Conserver un dégagement minimal de 6,35 mm/1/4 po entre le conduit d'air soufflé et les matériaux combustibles sur les 900 premiers millimètres (3 pi) du conduit.

Le non-respect de cette consigne entraîne des risques de dégâts matériels, de blessures corporelles ou de décès.

 **AVERTISSEMENT**

Risque lié aux objets lourds.

Plusieurs personnes sont nécessaires à la manipulation de l'unité.

Le non-respect de cette consigne peut entraîner dégâts à l'unité ou des blessures graves.



AVERTISSEMENT

Risque de choc électrique.

Ces tâches doivent être réalisées par une personne parfaitement qualifiée et formée.

Le non-respect de cette consigne peut entraîner des chocs électriques ou la mort.



ATTENTION

Arêtes métalliques vives.

Faites attention et portez des dispositifs de protection appropriés pour éviter tout contact accidentel avec des arêtes vives.

Le non-respect de cette consigne peut entraîner des blessures corporelles.

Les symboles suivants sont affichés sur les unités.



Ce symbole indique que le manuel d'utilisation doit être lu attentivement.



Ce symbole indique qu'un membre du personnel de service devrait manipuler cet équipement en se référant au manuel d'installation.



Ce symbole indique que des informations sont disponibles telles que le manuel d'utilisation ou le manuel d'installation.

INSTRUCTIONS DE SÉCURITÉ IMPORTANTES



AVERTISSEMENT

Pour réduire le risque d'explosion, d'incendie, de décès, de choc électrique, d'échaudure ou de blessures pour les personnes lors de l'utilisation de ce produit, suivez les précautions de base, notamment les suivantes :

GÉNÉRALITÉS

- L'équipement couvert dans ce manuel doit être installé par des techniciens de service et d'installation formés et expérimentés.
- Cet appareil n'est pas destiné à être utilisé par des personnes (y compris des enfants) ayant des capacités physiques, sensorielles ou mentales réduites, ou un manque d'expérience et de connaissances, à moins qu'elles n'aient reçu la supervision ou l'instruction concernant l'utilisation de l'appareil par une personne responsable de leur sécurité.
- Le système de réfrigérant est complètement assemblé et chargé. Tout le câblage interne est complet.
- L'unité est conçue pour être utilisée avec ou sans conduits. Des brides sont prévues pour fixer les conduits d'alimentation et de retour.
- Ces instructions expliquent la méthode recommandée pour installer l'unité autonome refroidie à l'air et les connexions de câblage électrique à l'unité.
- Ces instructions et toutes les instructions emballées avec tout équipement distinct requis pour constituer l'ensemble du système de climatisation doivent être lues attentivement avant de commencer l'installation. Notez en particulier « Procédure de démarrage » et les étiquettes et / ou étiquettes attachées à l'équipement.
- Bien que ces instructions soient conçues comme un guide général recommandé, elles ne remplacent en aucune façon les codes nationaux et/ou locaux. Les autorités compétentes devraient être consultées avant que l'installation ne soit effectuée. Voir d'autres publications pour obtenir des renseignements sur les codes et les normes.
- La taille de l'unité pour une installation proposée devrait être basée sur le calcul de la perte de chaleur effectué selon les méthodes de Air Conditioning Contractors of America (ACCA). Le conduit d'air devrait être installé conformément aux Normes de la National Fire Protection Association for the Installation of Air Conditioning and Ventilating Systems of Other Than Residence Type, NFPA No. 90A, et aux Systèmes de chauffage et de climatisation d'air chaud de type résidence, NFPA No. 90B. Lorsque les réglementations locales sont en contradiction avec les instructions, l'installateur doit respecter les codes locaux.

L'INSTALLATION

- Ce produit n'est pas destiné à être utilisé à des altitudes supérieures à 2 000 mètres (6 561 pieds). Pour les appareils destinés à être utilisés à des altitudes supérieures à 2 000 m (6 561 pieds), l'altitude maximale d'utilisation doit être indiquée.
- Avant utilisation, l'appareil doit être correctement installé comme décrit dans ce manuel.
- Communiquez avec le technicien d'entretien autorisé pour la réparation ou l'entretien de cette unité.
- Contactez le programme d'installation pour l'installation de cet appareil.
- Le climatiseur n'est pas destiné à être utilisé par de jeunes enfants ou des invalides sans surveillance.
- Les jeunes enfants devraient être surveillés pour s'assurer qu'ils ne jouent pas avec le climatiseur.
- Les travaux d'installation doivent être effectués conformément au Code national de l'électricité par du personnel qualifié et autorisé uniquement.
- Connectez-vous à un circuit d'alimentation correctement évalué, protégé et dimensionné pour éviter les surcharges électriques.
- Respectez toutes les procédures de sécurité recommandées par l'industrie, y compris l'utilisation de gants à manches longues et de lunettes de sécurité.
- Faites attention lors du déballage et de l'installation. Les bords du produit peuvent être tranchants.
- Gardez les matériaux d'emballage hors de la portée des enfants. Ces matériaux peuvent poser un risque d'étouffement pour les enfants.

OPÉRATION

- Cet appareil n'est pas destiné à être utilisé par des personnes (y compris des enfants) ayant des capacités physiques, sensorielles ou mentales réduites, ou un manque d'expérience et de connaissances, à moins qu'elles n'aient reçu une supervision ou une instruction concernant l'utilisation de l'appareil par une personne responsable de leur sécurité.
- Utilisez cet appareil uniquement aux fins prévues.
- N'essayez jamais de faire fonctionner cet appareil s'il est endommagé, défectueux, partiellement démonté ou s'il a des pièces manquantes ou cassées.
- Ne pas altérer les contrôles.

GENERAL INFORMATION

General

The equipment covered in this manual is to be installed by trained, experienced service and installation technicians.

The refrigerant system is completely assembled and charged. All internal wiring is complete.

The unit is designed for use with or without duct work. Flanges are provided for attaching the supply and return ducts.

These instructions explain the recommended method to install the air cooled self-contained unit and the electrical wiring connections to the unit.

These instructions and any instructions packaged with any separate equipment required to make up the entire air conditioning system should be carefully read before beginning the installation. Note particularly "Starting Procedure" and any tags and/or labels attached to the equipment.

While these instructions are intended as a general recommended guide, they do not supersede any national and/or local codes in any way. Authorities having jurisdiction should be consulted before the installation is made. See **Additional Publications** for information on codes and standards.

Size of unit for a proposed installation should be based on heat loss/gain calculation made according to methods of Air Conditioning Contractors of America (ACCA). The air duct should be installed in accordance with the Standards of the National Fire Protection Association for the Installation of Air Conditioning and Ventilating Systems of Other Than Residence Type, NFPA No. 90A, and Residence Type Warm Air Heating and Air Conditioning Systems, NFPA No. 90B. Where local regulations are at a variance with instructions, installer should adhere to local codes.

Shipping Damage

Upon receipt of equipment, the carton should be checked for external signs of shipping damage. If damage is found, the receiving party must contact the last carrier immediately, preferably in writing, requesting inspection by the carrier's agent.

Additional Publications

These publications can help when installing the heat pump. They can usually be found at the local library or purchased directly from the publisher. Be sure to consult the current edition of each standard.

National Electrical CodeANSI/NFPA 70

Standard for the Installation of Air Conditioning and Ventilating SystemsANSI/NFPA 90A

Standard for Warm Air Heating and Air Conditioning SystemsANSI/NFPA 90B

Load Calculation for Winter and Summer Air Conditioning ACCA Manual J Residential

Duct Design for Residential Winter and Summer Air Conditioning and Equipment Selection ACCA Manual D

For more information, contact these publishers:

ACCA **Air Conditioning Contractors of America**
1712 New Hampshire Ave. N.W.
Washington, DC 20009
Telephone: (202) 483-9370
Fax: (202) 234-4721

ANSI **American National Standards Institute**
11 West Street, 13th Floor
New York, NY 10036
Telephone: (212) 642-4900
Fax: (212) 302-1286

ASHRAE **American Society of Heating, Refrigeration and Air Conditioning Engineers, Inc.**
1791 Tullie Circle, N.E.
Atlanta, GA 30329-2305
Telephone: (404) 636-8400
Fax: (404) 321-5478

NFPA **National Fire Protection Association**
Batterymarch Park
P.O. Box 9101
Quincy, MA 02269-9901
Telephone: (800) 344-3555
Fax: (617) 984-7057

Heat Pump Wall Mount Model Nomenclature

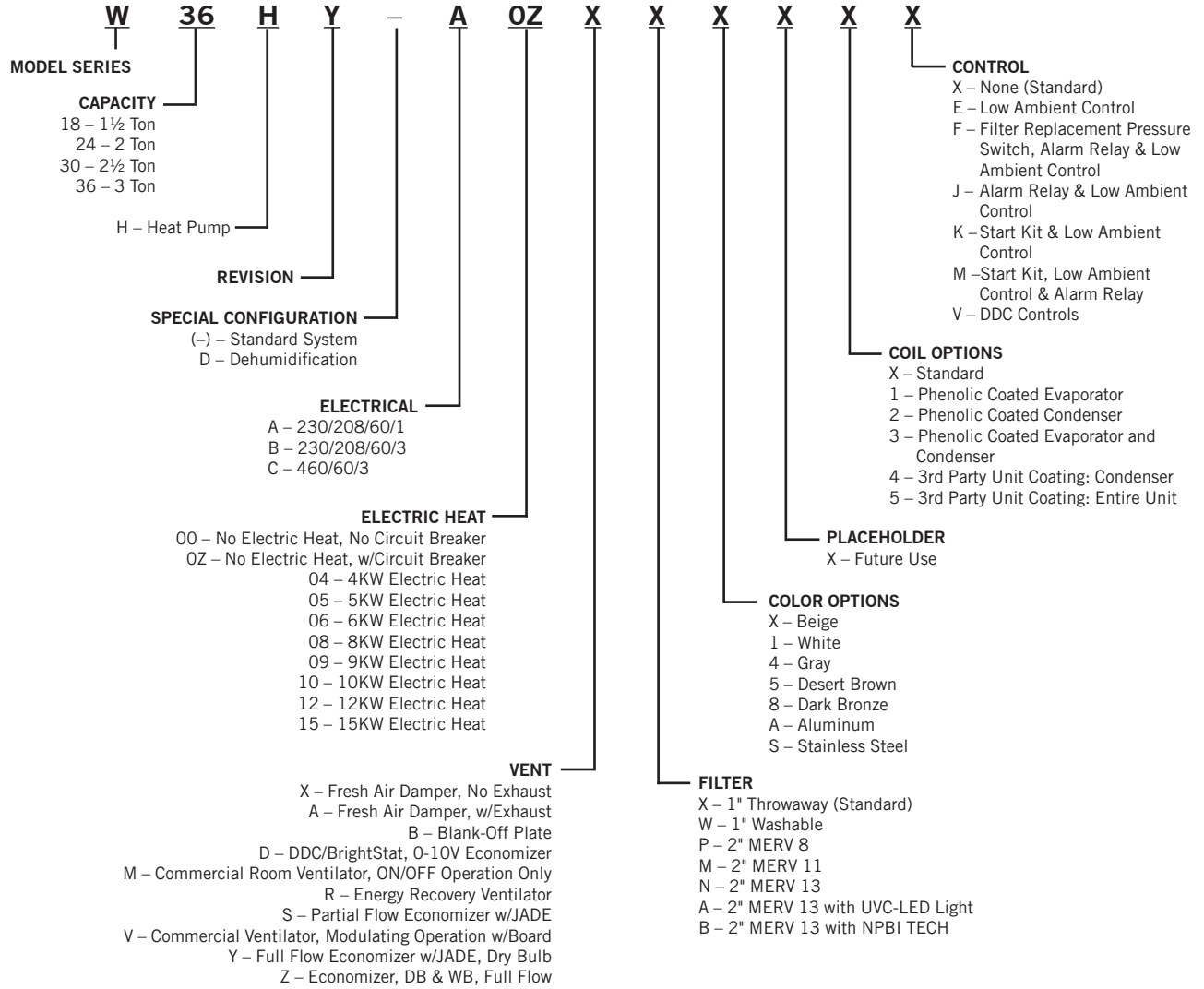

Duct Work

All duct work, supply and return, must be properly sized for the design airflow requirement of the equipment. Air Conditioning Contractors of America (ACCA) is an excellent guide to proper sizing. All duct work or portions thereof not in the conditioned space should be properly insulated in order to both conserve energy and prevent condensation or moisture damage.

Refer to the Maximum ESP of Operation table on page 45.

Design the duct work according to methods given by the Air Conditioning Contractors of America (ACCA). When duct runs through unheated spaces, it should be insulated with a minimum of 1" of insulation. Use insulation with a vapor barrier on the outside of the insulation. Flexible joints should be used to connect the duct work to the equipment in order to keep the noise transmission to a minimum.

For all models, a 1/4" clearance to combustible material for the first 3' of duct attached to the outlet air frame is required. See **Ducted Applications** on page 14 and Figures 3A and 3B (pages 17 and 18) and Figure 4 (page 19) for further details.

Ducts through the walls must be insulated and all joints taped or sealed to prevent air or moisture entering the wall cavity.

Some installations may not require any return air duct. A metallic return air grille is required with installations not requiring a return air duct. The spacing between louvers on the grille shall not be larger than 5/8".

Any grille that meets with 5/8" louver criteria may be used. It is recommended that Bard Return Air Grille Kit RG-2W through RG-3W or RFG-2W through RFG-3W be installed when no return duct is used. Contact distributor or factory for ordering information. If using a return air filter grille, filters must be of sufficient size to allow a maximum velocity of 400 fpm.

NOTE: *If no return air duct is used, applicable installation codes may limit this cabinet to installation only in a single story structure.*

Filters

A 1" throwaway filter is standard with each unit. The filter slides into position making it easy to service. This filter can be serviced from the outside by removing the filter access panel. A 1" washable filter and 2" pleated filter are also available as optional accessories. The internal filter brackets are adjustable to accommodate the 2" filter by bending two tabs down on each side of the filter support bracket.

Fresh Air Intake

All units are built with fresh air inlet slots punched in the service door.

If the unit is equipped with a fresh air damper assembly, the assembly is shipped already attached to the unit. The damper blade is locked in the closed position. To allow the damper to operate, the maximum and minimum blade position stops must be installed (see Figure 1).

Graphs found on pages 48 and 49 give approximate fresh air amounts based on the blade position stop location.

All capacity, efficiency and cost of operation information is based upon the fresh air blank-off plate in place and is recommended for maximum energy efficiency.

The blank-off plate is available upon request from the factory and is installed in place of the fresh air damper shipped with each unit.

FIGURE 1
Fresh Air Damper

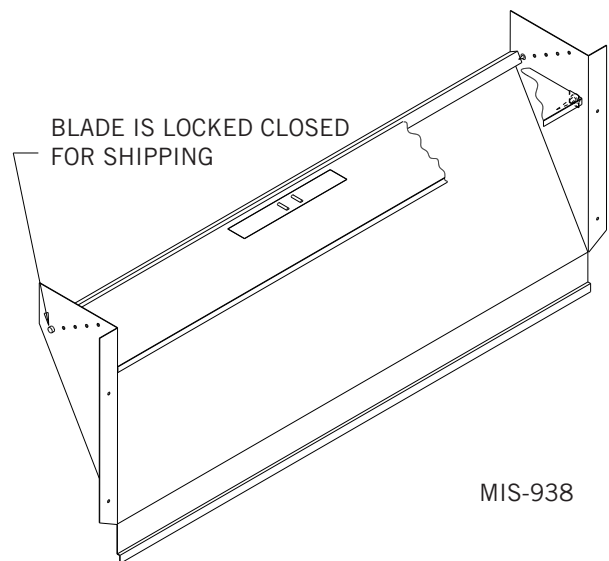

Basic Installation Design and Application Planning

Successful unit installations require proper planning and site inspection before installation begins. Before installing the wall mount unit, make sure that all service and airflow clearances are met and that the unit can meet all applicable code and regulation requirements. Provide an inspection of both the inside and outside of the structure by reviewing floorplans and/or visiting the installation site.

Wall Construction

The wall must be inspected to ensure that the weight of the unit can be supported. Be sure to review all applicable construction codes and regulations including seismic requirements. When inspecting wood frame walls, the wall construction must be strong and rigid enough to carry the weight of the unit without transmitting any unit vibration. It is important that the side unit wall mounting lags and optional bottom bracket are supported by structural members inside the wall cavity. Concrete block and brick walls must be thoroughly inspected to ensure that they are capable of carrying the weight of the installed unit. Metal buildings must contain structural components to support the unit weight. If heavily corrugated siding is present, it may need to be trimmed and flashed similar to a window to provide a flat, even surface to attach and seal the unit to the wall. Heavy gauge corrugations that would be present on shipping containers and blast-proof structures may require the installation of a metal plate over the corrugated area. It is important that the unit area is weatherized and sealed to avoid air and water infiltration into the area between the unit and the wall.

Outdoor Area Inspection

Inspect the outdoor area of the jobsite or review construction plans and locate the area where the wall mount is to be installed. The outdoor area must be free from obstructions including fences, bushes and walls that will hinder unit operation regarding outdoor condenser airflow and unit serviceability. Do not install units in enclosed areas that limit the amount of ambient temperature airflow. Warm air will exit the front condenser section of the unit, and outdoor ambient temperature air must be able to enter side intake condenser openings of the unit. Portable or modular building placement must be in a way that the wall mount units have a constant supply of outdoor air for proper unit operation. Make sure that the service panels of the unit are accessible. Inspect wall surfaces for obstructions that could hinder unit installation and servicing including outdoor electrical conduits, junction boxes, wall drains, vent hoods, windows, doors, overhangs and posts.

NOTE: Before mounting the heat pump unit, consideration should be given to the condensate removal from the outdoor coil when in heating mode. The unit must be mounted high enough above grade to ensure that ice will not build up under the unit and come into contact with the base of the unit. If allowed, this could cause damage to the coil and other base components. Also, be sure there are no air obstructions to the sides or front of the unit, such as bushes or fences, that would inhibit condenser airflow.

Condensate Water Drainage

Review all codes and requirements for unit condensate drainage. A clear, flexible PVC drain hose (3/4" ID, 1" OD) extends from the drain pan in the upper section of the unit and extends down to the unit base. An opening is supplied towards the back of the unit base for the drain hose to pass through, and the hose extends 1" to 2" below the unit base. Water removed from the indoor air (condensate) will be expelled from the unit in large amounts during cooling operation through the hose. Units running in cooling operation in cold outdoor below freezing conditions can cause the condensate to freeze after leaving the drain hose. In the event the drain hose is connected to a drain system of some type, it must be an open or vented type system to ensure proper drainage throughout seasonal use.

Indoor Ducted and Non-Ducted Applications

Air distribution inside the structure being conditioned plays an important role in making sure the area is a consistent temperature. Improper air distribution can result in areas being cooler or warmer, electrical equipment not receiving sufficient airflow or occupancy discomfort felt inside an area. Thermostat or indoor temperature sensor placement inside the area being conditioned also plays an important role in indoor climate control.

Indoor Supply Airflow

Indoor installation areas must provide a non-restrictive path for the conditioned supply air to leave supply grilles and registers. Inspect the area to ensure that all indoor portions of the room or rooms will have access to supply air. Ductwork may be used to ensure proper air circulation and all provided ductwork guidelines and clearances must be followed. Non-ducted applications must use a supply louver grille installed over the supply opening inside the room. Be sure to adjust supply deflectors to properly disperse the conditioned supply air to all parts of the room. Avoid closing sections of the supply grilles which would cause unneeded supply duct pressurization.

Indoor Return Airflow

A non-restrictive path for room air returning to the center section of the unit must be provided inside the room. Avoid placing objects including furniture, electronics equipment, equipment racks and cabinets directly in front of the unit return grilles and registers. Bard recommends at least 2' between solid objects and return grilles or registers. Ductwork may be used to ensure proper air circulation and all provided ductwork guidelines and clearances must be followed. Non-ducted applications must use a return louver grille installed over the return opening inside the room.

Ducted Applications

Field fabricated supply and return duct work may be installed inside the structure being conditioned. A short supply and/or return stub duct may be connected to the unit supply and return flanges before unit installation to help with duct connections inside the structure. Supply and return ducts must be properly sized for the design airflow requirement of the equipment. Air Conditioning Contractors of America (ACCA) is an excellent guide to proper sizing. All duct work or portions thereof not in the conditioned space should be properly insulated in order to conserve energy, reduce heat conductivity, and prevent condensation or moisture damage. Refer to Maximum External Static Pressure (ESP) of Operation Table 17 on page 45. Design the duct work according to methods given by the Air Conditioning Contractors of America (ACCA). When duct work is installed in unheated spaces, it should be insulated with a minimum of 1" of insulation. Use insulation with a vapor barrier on the outside of the insulation. Flexible joints should be used to connect the duct work to the equipment in order to keep the noise transmission to a minimum. Ducts through the walls must be insulated and all joints taped or sealed to prevent air or moisture from entering the wall cavity.

The unit itself is suitable for 0" clearance, but the supply air duct flange and the first 3' of supply air duct require a minimum of 1/4" clearance to combustible material for all models. However, it is generally recommended that a 1" clearance is used for ease of installation and maintaining the required clearance to combustible material. See Figures 3A and 3B on pages 17 and 18 for details on opening sizes.

WARNING

Fire hazard.

Maintain minimum 1/4" clearance between the supply air duct and combustible materials in the first 3' of ducting.

Failure to do so could result in fire causing damage, injury or death.

Free Blow Applications

Some installations may not require extensive supply duct work throughout the structure and are referred to as free blow applications. A short field-fabricated supply duct must be used in the wall cavity to transition between the supply collar on the unit and the supply louver grille in the room. The duct must be properly insulated in order to conserve energy, reduce heat conductivity and prevent condensation or moisture damage. All joints must be taped or sealed to prevent air or moisture entering the wall cavity. Follow all clearances including distances to combustible materials and all instructions provided in this manual. A non-restrictive metallic supply air grille with deflectors is required for free blow applications. Contact the local Bard distributor or visit www.bardhvac.com for ordering information.

A metallic return air grille is required for non-ducted applications. The spacing between louvers on the grille shall not be larger than 5/8". It is recommended that a Bard Return Air Grille Kit be installed that is designed specifically for the wall mount product. Contact the local Bard distributor or visit www.bardhvac.com for ordering information. A field-supplied return grille that meets the 5/8" louver criteria and does not cause the unit to exceed the maximum specified external static pressure (ESP) may be used. If using a return air filter grille, filters must be of sufficient size to allow a maximum velocity of 400 fpm. Filter return air grilles do not filter air being brought into the structure through ventilation options including fresh air dampers, ventilators, economizers and energy recovery ventilators. Be sure to install the return grille with the louvers pointed downward towards the floor. This will help ensure return air is drawn upward from the floor and improve air circulation in the room.

NOTE: *If no return air duct is used, applicable installation codes may limit this cabinet to installation only in a single story structure.*

Thermostat or Indoor Temperature Sensor Placement

The location and installation of the thermostat or temperature sensor that monitors indoor temperature is very important regarding unit operation. Avoid placing the thermostat in an area exposed to direct sunlight or air from doorways leading outdoors. Use a piece of insulating material to close off conduit openings or holes in the wall surface for wire entry into the thermostat or temperature sensor. This will help avoid non-conditioned air from entering the thermostat and effecting temperature and/or humidity readings. As common practice, the thermostat or temperature sensor should measure the temperature of the air being returned to the unit, and not the conditioned air being supplied by the unit. Placing the thermostat or temperature sensor near a return air opening will normally result in optimal unit performance.

Unit Installation

Make sure to have the proper tools at the work site that are needed for unit installation. The following steps are provided to ensure the unit is installed properly to the wall surface, and that the unit will provide years of service with minimal service requirements.

Materials/Tools List

Additional hardware and miscellaneous supplies are needed for installation. These items are field supplied and must be sourced before installation. This list also includes tools needed for installation.

- Appropriate safety gear including gloves and safety glasses
- 5/16" hex bit with drill driver
- Phillips head screwdriver
- Small straight (thermostat) screwdriver
- Tape measure
- Leveling device
- Two (2) tubes of caulk and caulk gun
- Utility knife
- Tools for cutting holes in the wall surface (if needed)
- Electrical components and wiring along with electrical tools
- Multimeter
- Wall fasteners for side flanges, bottom mounting bracket and top rain flashing.
- Duct tape and/or other duct sealing materials.

Wall Preparation

1. Two holes for the supply and return air openings must be cut through the wall as shown in Figures 3A and 3B on pages 17 and 18. Be sure the openings are square and level. Follow all clearances including distances to combustible materials and all instructions provided in this manual.
2. Review all electrical requirements provided in this manual and plan out electrical entrances into the building. Also plan electrical conduit routing and thermostat placement, if necessary.
3. Install necessary duct work and prepare the openings for unit installation.
4. Clean the exterior wall where the unit is to be installed and make sure it is able to provide a smooth, level, debris-free surface. Remove all construction debris from the supply, return and electrical hole cutting process.

Wall Mount Installation to Wall Surface

1. Remove packaging from unit and make sure unit is not damaged before installation. A top rain

flashing is supplied for field use and is mounted to the back of the unit for shipping. Remove rain flashing before locating the unit against wall. Top rain flashing is required to avoid water entering the area behind the unit that is against the wall. A bottom mounting bracket, attached to the skid for shipping, is provided for ease of installation but is not required. Review all requirements listed on unit labels and on serial plate located on the side of the unit.

2. Locate and mark bolt hole locations and bottom mounting bracket location. Install bottom mounting bracket with field-supplied fasteners to wall if it is to be used (optional). Bracket must be level and installed in the correct location to help support the unit during the installation process (see Figures 3A and 3B).
3. Position the wall mount unit close to the wall surface where it will be installed. Install rain flashing at the top of the unit facing the wall by hooking the hem bend into the rear bend of the unit top (see Figures 3A and 3B).
4. Apply a liberal amount of caulk on left and right cabinet side wall mount brackets and back of top rain flashing. Place unit back surface flush against wall. Unit must be level to ensure proper condensate drainage. Optional bottom bracket may be used to help support the unit.
5. Units are secured to the wall by using field-supplied fasteners along each side of the wall mount through the built-in wall mounting brackets. It is the responsibility of the installer to select the proper fastener to secure the unit to the wall based on wall construction and applicable building codes. Typical installations may include 5/16" fasteners with 7/8" diameter flat washers. Be sure unit is securely mounted and all weight-bearing fasteners are attached to the weight supporting structural members of the wall.
6. Apply a bead of caulk between the back of the unit top and the front surface of the top rain flashing (see Figures 3A and 3B).
7. Connect unit duct work from the inside of the building following all clearances and instructions provided. For additional mounting rigidity, the return air and supply air frames or collars can be drilled and screwed or welded to the structural wall itself (depending upon wall construction). Be sure to use code approved duct tape or other sealing materials to seal the duct work to the unit.
8. On side-by-side installations, maintain a minimum of 20" clearance on right side to allow access to control panel and heat strips, and to allow proper airflow to the outdoor coil. Additional clearance may be required to meet local or national codes.

TABLE 1
Clearance Required for Service Access and Adequate Condenser Airflow

Model	Left Side	Right Side
W18H W24H W30H W36H	15"	20"

TABLE 2
Minimum Clearances Required to Combustible Materials

Model	Supply Air Duct (1st 3')	Cabinet
W18H W24H	1/4"	0"
W30H W36H	1/4"	0"

1. Follow all national, state, and local codes and regulations regarding the installation of heating and cooling equipment regarding Single Packaged Vertical Units (SPVU) including electrical access clearances.
2. Field ventilation installation with the unit installed requires 40" on the left or right side of the unit.
3. Bard recommends a minimum of 10' between the unit front condenser air outlet and solid objects including fences, walls, bushes and other airflow obstructions.
4. Bard recommends a minimum of 15' between the condenser air outlets of two units that are facing each other.
5. Bard recommends a minimum clearance of 4" under the unit cabinet for condenser defrost drain age during heat pump operation.

FIGURE 2
Unit Dimensions

	Width (W)	Depth (D)	Height (H)	Supply		Return		E	F	G	I	J	K	L	M	N	O	P	Q	R	S	T
				A	B	C	B															
W18HY W24HY	33.300	17.125	74.563	7.88	19.88	11.88	19.88	35.00	10.88	29.75	20.56	30.75	32.06	33.25	31.00	2.63	34.13	26.06	10.55	4.19	12.00	9.00
W30HY W36HY	38.200	17.125	74.563	7.88	27.88	13.88	27.88	40.00	10.88	29.75	17.93	30.75	32.75	33.25	31.00	2.75	39.13	26.75	9.14	4.19	12.00	9.00

All dimensions are in inches. Dimensional drawings are not to scale.

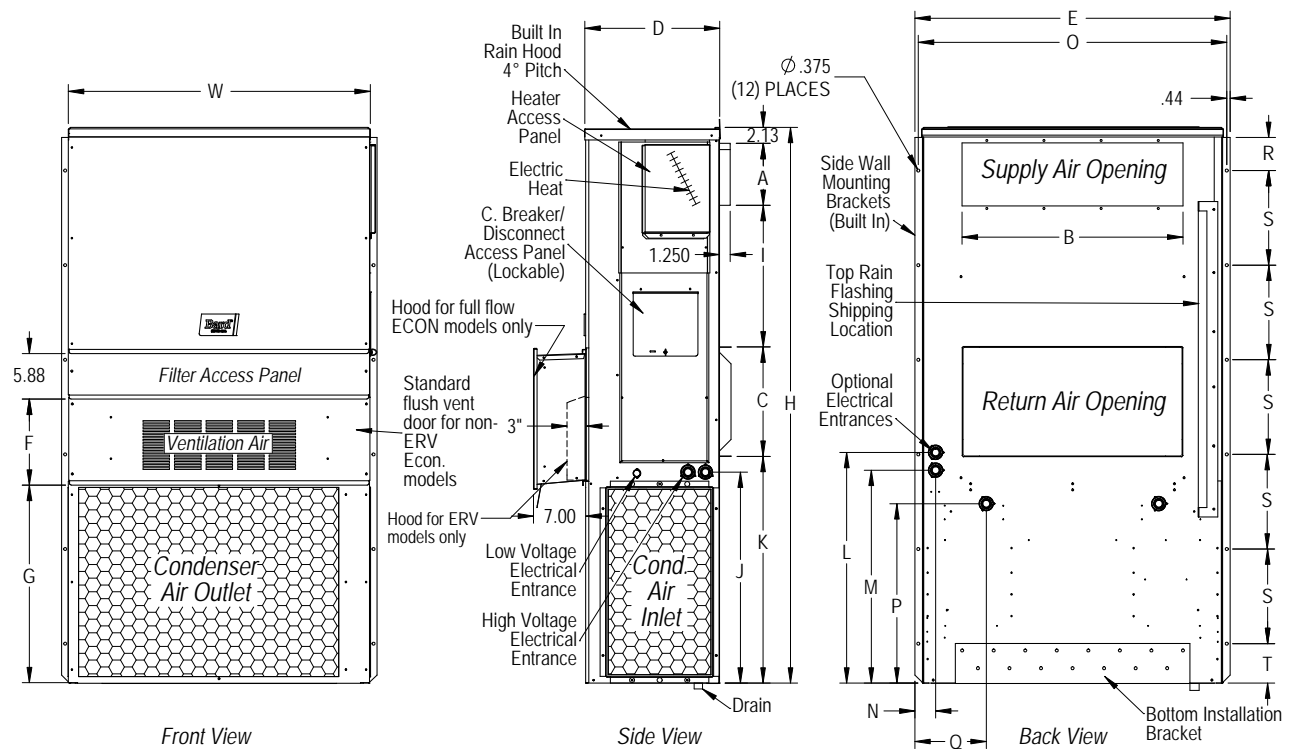

MIS-3976 A

FIGURE 3A
W18H, W24H
Mounting Instructions

CRITICAL NOTE: SEAL WITH BEAD OF CAULKING ALONG ENTIRE LENGTH OF TOP.

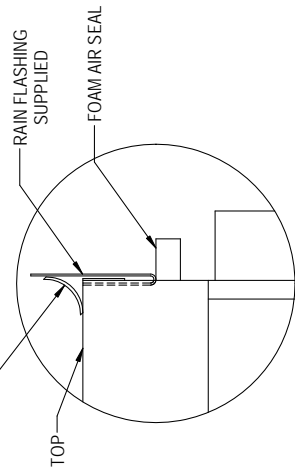

	A	B	C	D	E
REQUIRED DIMENSIONS TO MAINTAIN 1/4" MIN. CLEARANCE FROM COMBUSTIBLE MATERIALS	20 1/2	8 1/2	6 13/16	3 3/4	20 1/4
REQUIRED DIMENSIONS TO MAINTAIN RECOMMENDED 1" CLEARANCE FROM COMBUSTIBLE MATERIALS	22	10	6 1/16	4 1/2	19 1/2

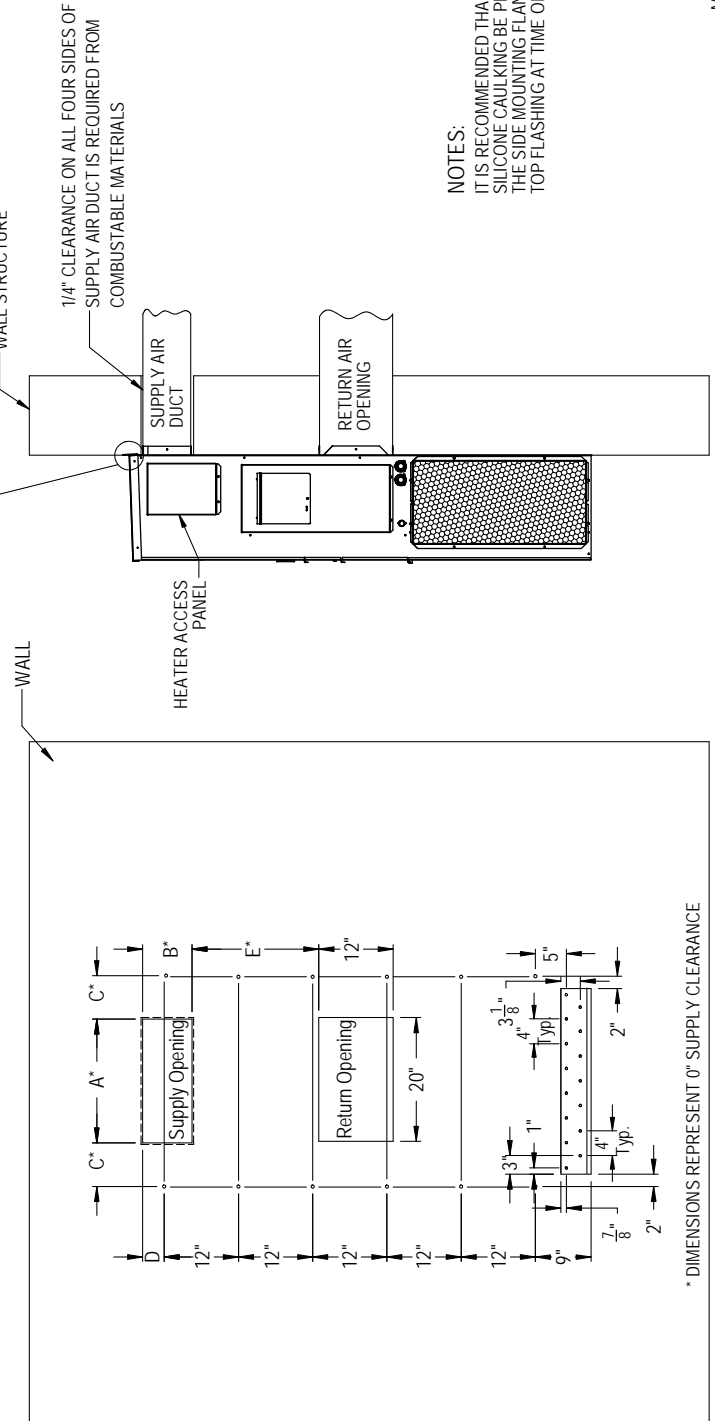

NOTES:
 IT IS RECOMMENDED THAT A BEAD OF SILICONE CAULKING BE PLACED BEHIND THE SIDE MOUNTING FLANGES AND UNDER TOP FLASHING AT TIME OF INSTALLATION.

Right Side View

Wall Opening and Hole Location View

MIS-4036 B

FIGURE 4
Electric Heat Clearance – All Models

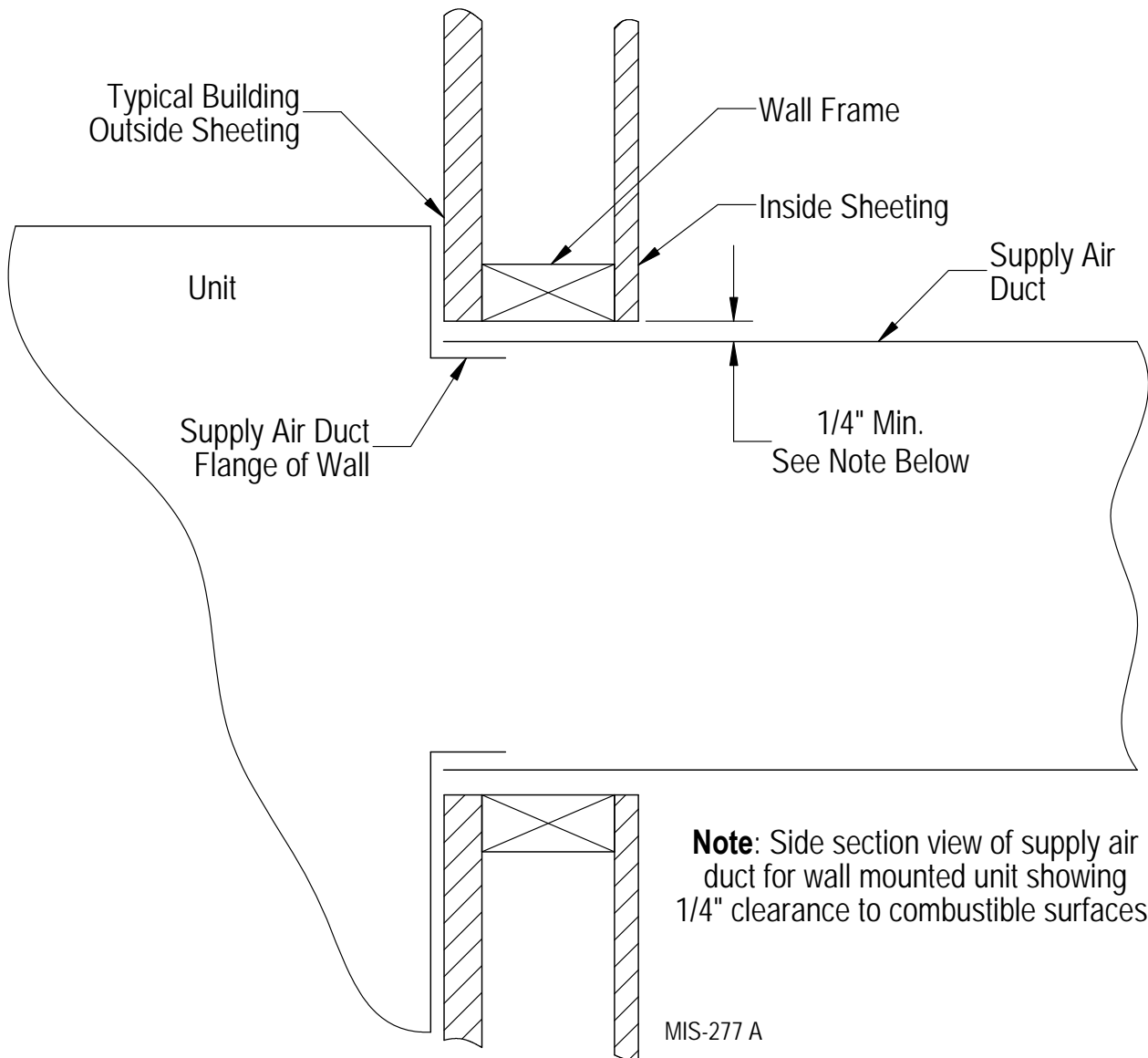

⚠ WARNING

Fire hazard.

Maintain minimum 1/4" clearance between the supply air duct and combustible materials in the first 3' of ducting.

Failure to do so could result in fire causing damage, injury or death.

FIGURE 5
Wall Mounting Instructions

SEE FIGURES 3A-B – MOUNTING INSTRUCTIONS

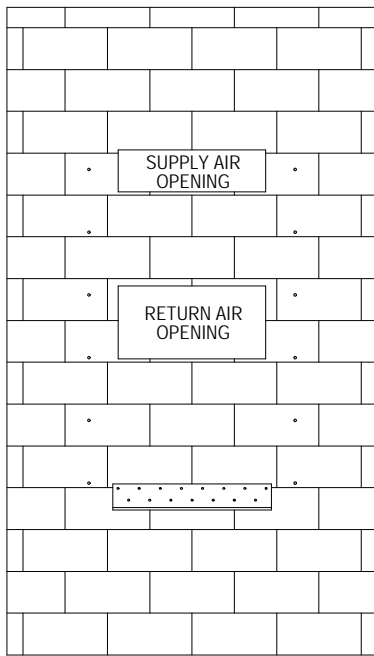

CONCRETE BLOCK WALL INSTALLATION

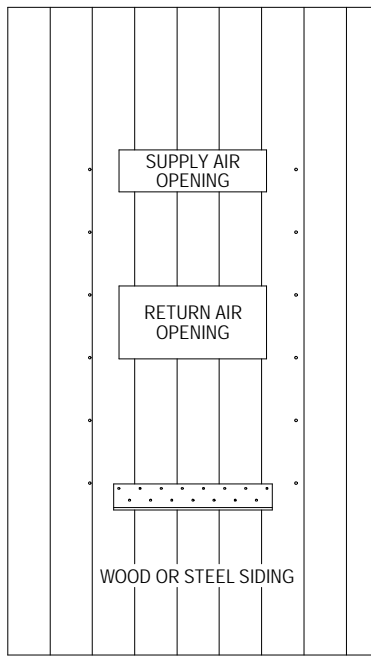

WOOD FRAME WALL INSTALLATION

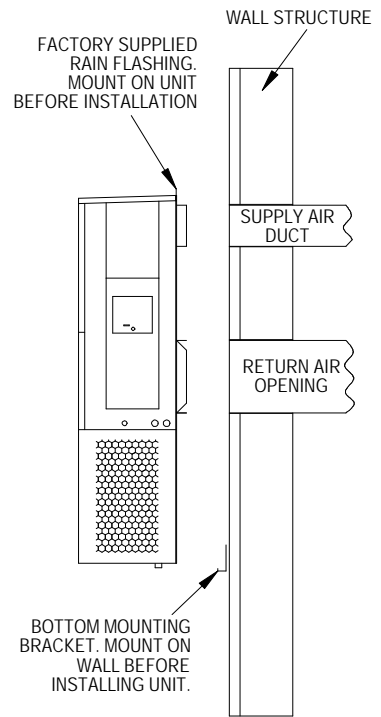

SIDE VIEW

MIS-548 A

FIGURE 6
Wall Mounting Instructions

SEE UNIT DIMENSIONS, FIGURE 2,
FOR ACTUAL DIMENSIONS.

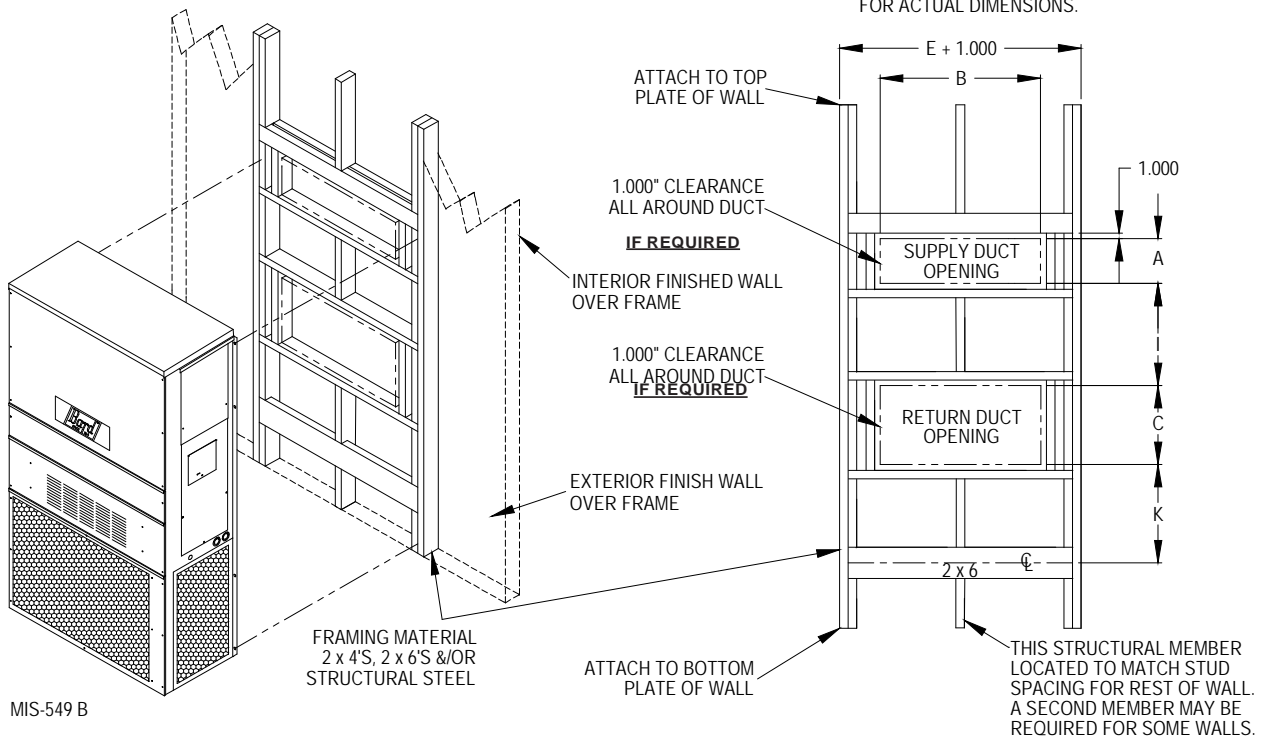

MIS-549 B

FIGURE 7
Common Wall Mounting Installations

Non-Ducted Installations

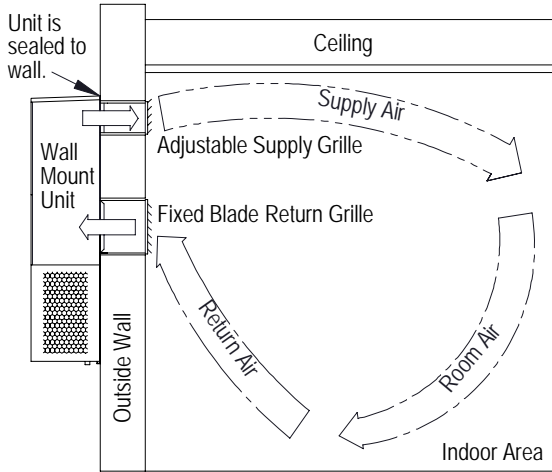

Non-ducted installations supply conditioned air into indoor room areas without extensive duct work. The supply airstream is directed by adjusting the 4-way supply grille to reach areas being conditioned. The supply air mixes with the room air and cools or heats occupants and/or equipment in the area. Unconditioned room air is returned to the unit through the return grille. Avoid supply air leaving supply grille and re-entering the unit return grille without mixing with room air.

Ducted Installations

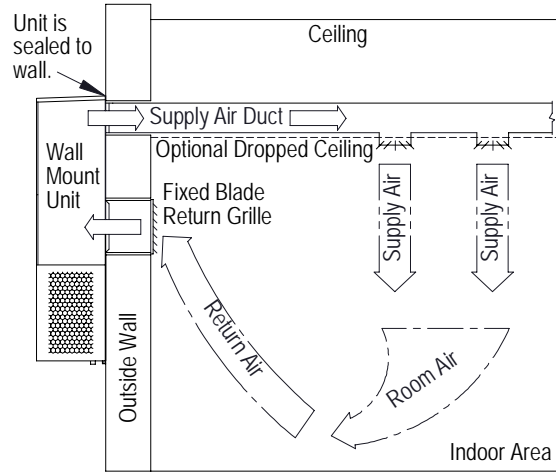

Ducted installations supply conditioned air into indoor room areas using solid or flexible ducts. The supply air is distributed throughout a single area or multiple areas. The supply air mixes with the room air and cools or heats occupants and/or equipment. Unconditioned room air is returned to the unit through a return grille or return duct work. Avoid using restrictive duct work to provide the best unit performance and efficiency. Review duct static pressure requirements provided in this manual.

Outdoor Wall Curb Installations

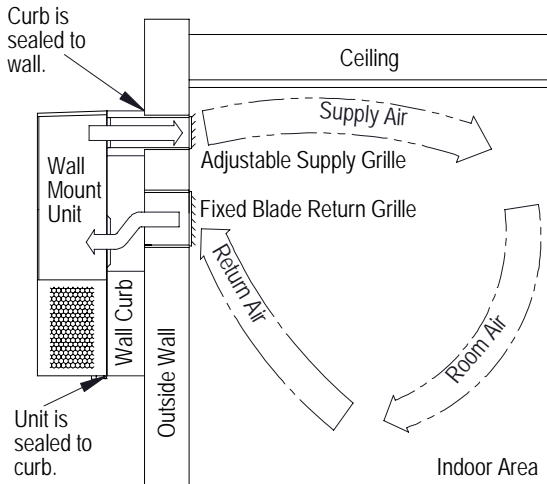

Outdoor Wall curbs are installed between the wall mount unit and the outer wall surface. Wall curb use may avoid resizing supply and return openings that are currently in an existing wall. Wall curbs may also provide sound isolation and indoor area sound reduction. Various curb options are available, and it is important to select a curb that will meet the application requirements and also be the correct size for the unit. Unit duct static requirements cannot be exceeded when using a wall curb. Follow all instructions provided with the wall curb when installing the product.

WAPR11 Indoor Sound Plenum Installations

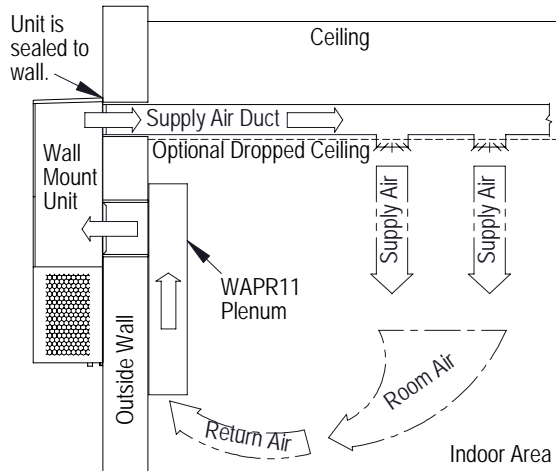

Indoor sound plenums are installed inside the room over the unit return air opening. Plenum use can provide sound isolation and indoor area sound reduction. The WAPR11 sound plenum provides a single solution for all unit tonnage sizes. The WAPR11 may be installed horizontally or vertically in the room. Unit duct static requirements cannot be exceeded when using a sound plenum. Follow all instructions provided with the sound plenum when installing the product.

MIS-550 D

Wiring – Main Power

WARNING

Electrical shock hazard.

Do not operate this equipment without an earth ground attached and always disconnect the remote electric power supplies before servicing.

Electrical shock can result in serious injury or death.

Refer to the unit rating plate for wire sizing information and maximum fuse or circuit breaker size. Each outdoor unit is marked with a “Minimum Circuit Ampacity”. This means that the field wiring used must be sized to carry that amount of current. Depending on the installed KW of electric heat, there may be two field power circuits required. If this is the case, the unit serial plate will so indicate. All models are suitable only for connection with copper wire. Each unit and/or wiring diagram will be marked “Use Copper Conductors Only”. These instructions **must be** adhered to. Refer to the National Electrical Code (NEC) for complete current carrying capacity data on the various insulation grades of wiring material. All wiring must conform to NEC and all local codes.

The electrical data lists fuse sizes for all models including the most commonly used heater sizes. Also shown are the number of field power circuits required for the various models with heaters.

The unit rating plate lists a maximum fuse or circuit breaker that is to be used with the equipment. The correct size must be used for proper circuit protection and also to assure that there will be no nuisance tripping due to the momentary high starting current of the compressor motor.

The disconnect access door on this unit may be locked to prevent unauthorized access to the disconnect. To convert for the locking capability, bend the tab located in the bottom left-hand corner of the disconnect opening under the disconnect access panel straight out. This tab will now line up with the slot in the door. When shut, a padlock may be placed through the hole in the tab preventing entry.

See page 28 for important information on three phase scroll compressor start ups.

See Table 13 on page 39 for electrical specifications.

Wiring – Low Voltage

All 230/208V 1 phase and 3 phase equipment have dual primary voltage transformers. All equipment leaves

the factory wired on 240V tap. For 208V operation, reconnect from 240V to 208V tap. The acceptable operating voltage range for the 240 and 208V taps are:

TAP	RANGE
240	253 – 216
208	215 – 197

NOTE: The voltage should be measured at the field power connection point in the unit and while the unit is operating at full load (maximum amperage operating condition).

For low voltage wiring, an 18 gauge copper, color-coded cable is recommended. See Table 7 on page 24 for more information.

Low Voltage Connections

These units use a 24-volt AC low voltage circuit.

C terminal is 24VAC common and is grounded.

G terminal is the indoor blower input.

Y1 terminal is the 1st Stage input for cooling.

Y2 terminal is the 2nd Stage compressor input for cooling (if equipped with an economizer).

B/W1 terminal is the reversing valve input. The reversing valve must be energized for heating mode.

W2 terminal is the 1st stage electric heat (if equipped).

W3 terminal is the 2nd stage of electric heat or emergency heat input (if equipped). Two stages of electric heat are not available on units with dehumidification.

A terminal is the ventilation input. This terminal energizes any factory-installed ventilation option and indoor blower.

D terminal is the dehumidification input. If installed, this terminal energizes any factory-installed dehumidification option.

L terminal is 24 volt alarm active output.

For units equipped with an alarm relay:

1 terminal is the normally closed contact on the relay.

2 terminal is the normally open contact on the relay.

3 terminal is the common contact on the relay.

DDC Connections

11 terminal is filter switch, common contact on auxiliary terminal strip (F Control option only)

12 terminal is filter switch, normally open contact on auxiliary terminal strip (F Control option only)

Unit Shutdown Feature (Standard on All Models)

The RT terminal is the 24VAC transformer output, and the R terminal is the 24VAC hot terminal for the operation of the equipment. RT and R are connected with a brass jumper bar which can be removed and RT and R connected to an external NC (normally closed) contact such as a fire/smoke detector that will cause shutdown of the equipment upon activation.

Balanced Climate™ Feature (Standard on All Models)

All units are equipped with the capability of running in Balanced Climate mode. This mode is designed to enhance the comfort level by reducing the indoor airflow amount and extending the run time to help extract more humidity during cooling operation. In heating mode, the reduced airflow provides a warmer supply air temperature creating more comfortable heat. The Y1 terminal is the 24VAC input for Balanced Climate compressor cooling operation. The Y2 terminal is the 24VAC input for compressor cooling standard operation. Y1 and Y2 are connected with a brass jumper bar which can be removed to enable Balanced Climate mode. Units with an economizer will not have the brass jumper installed. Refer to vent manuals for instructions on how Balanced Climate works with each vent.

NOTE: Units with mechanical dehumidification require an additional connection to be made when enabling Balanced Climate. Refer to dehumidification supplemental instructions for this step.

To operate in Balanced Climate mode, a 2-stage cooling thermostat is required. The lower indoor airflow operation is overridden by utilizing a 2-stage thermostat. If the call for cooling is not satisfied within a given time frame or temperature differential (specified by the thermostat), the thermostat will send a signal to Y2 which then increases the blower speed back to the selected speed. See pages 40 – 41 for blower speed selection options.

Refer to page 28 for additional Balanced Climate requirements and limitations.

Dehumidification Feature (Optional)

The D terminal is the 24VAC input for dehumidification operation on dehumidification hot gas reheat equipped units. When 24VAC is applied to the D terminal, a 3-way valve solenoid is energized. The reheat coil located behind the evaporator coil is then active to reheat the supply air during cooling mode. This allows humidity to be removed from the air entering the unit without a large amount of sensible cooling capacity. During dehumidification, the indoor blower speed is reduced to help with the humidity removal. A humidity sensing thermostat or humidistat is required to control dehumidification operation.

Ventilation Features (Optional)

See ventilation instructions provided with unit for low voltage wiring.

Low Ambient Control (LAC)

The low ambient control is a pressure switch that is attached to the liquid line of the system and monitors high side pressure. Operation of the LAC occurs as outdoor temperatures drop below 60°F. On/Off and modulating controls are used which operate based on pressure changes caused by outdoor temperature changes. On/Off LAC operation cycles the condenser

fan on/off to maintain desired liquid pressure while modulating LAC operation is factory adjusted and slows the condenser fan speed (rpm).

Outdoor Temperature Switch and Freeze Protection Thermostat

An outdoor temperature switch and an evaporator freeze protection thermostat is supplied with all units that have a low ambient control. The outdoor switch disables Balanced Climate mode (if enabled) when the temperature drops below 50°F. This prevents potential evaporator coil freeze up issues. For units with mechanical dehumidification, this switch must remain disconnected when Balanced Climate mode is not being used. Refer to unit wiring diagram. The freeze thermostat cuts out compressor operation if the evaporator begins to freeze up.

Alarm Relay Feature (Controls Option)

The alarm relay provides a set of NO (normally open) and NC (normally closed) pilot duty contacts that operate when the compressor control module locks out compressor operation because of a high or low system refrigerant pressure event.

Dirty Filter Switch Indicator (DFS)

The switch is adjustable and measures pressure drop across the unit filter surface. When pressure drop is higher than the switch setting, NO contacts are provided to indicate the filter needs to be serviced. Refer to page 42 for instructions on making switch adjustments.

TABLE 3
Low Voltage Connections

	Standard Units	Units w/ Economizers
Fan Only	Energize G	Energize G
1st Stage Cooling Mode/ Balanced Climate	Energize Y1, G	Energize Y1, G (Free Cooling or Compressor Cooling)
2nd Stage Cooling Mode	Energize Y2 to override Balanced Climate mode when Y1-Y2 jumper is removed	Energize Y1, Y2, G (Compressor Cooling)
1st Stage Heating	Energize Y1, B/W1	Energize Y1, B/W1
2nd Stage Heating (if employed)	Energize Y1, B/W1, W2	Energize Y1, B/W1, W2
Ventilation	Energize A	Energize A
Dehumidification (if employed)	Energize D	Energize D
Emergency Heat	Energize G, W2, W3	Energize G, W2, W3

**TABLE 4
Wall Thermostats**

Part Number	Predominate Features
8403-060 (1120-445)	3 Stage Cool; 3 Stage Heat – HP or Conventional; Programmable/Non-Programmable; Auto or Manual Changeover; Dehumidification Output
8403-090	2 Stage Cool, 3 Stage Heat – Heat Pump; 2 Stage Cool, 2 Stage Heat – Conventional; Programmable/Non-Programmable; Auto or Manual Changeover
8403-092	2 Stage Cool, 3 Stage Heat – Heat Pump; 2 Stage Cool, 2 Stage Heat – Conventional; Programmable/Non-Programmable; Auto or Manual Changeover; Wi-Fi
8403-095	1 stage Cool, 2 stage Heat – Heat Pump; 1 stage Cool, 1 stage Heat – Conventional; Programmable/Non-Programmable; Auto or Manual changeover

**TABLE 5
Humidity Controls**

Part Number	Predominate Features
8403-100* (H6062A1000)	Electronic humidistat DPST Humidity range 10-90% with adjustable stops
8403-047 (H200-10-21-10)	Electronic dehumidistat SPST, closes-on-rise Humidity range 10-90% with adjustable stops

* If using 8403-100 humidistat, it must be configured for dehumidification in the Setup menu.

**TABLE 7
Thermostat Wire Size**

Transformer VA	FLA	Wire Gauge	Maximum Distance In Feet
55	2.3	18 gauge	60
		16 gauge	100
		14 gauge	160
		12 gauge	250

**TABLE 6
CO₂ Controllers**

Part Number	Predominate Features
8403-056	CO ₂ ventilation control with digital display. Normally Open SPST (Default: Close at 800ppm)
8403-096	Normally Open SPST relay closes-on-rise 24V dual wave length sensor. Default setting 950ppm, adjustable to 0-2000ppm Default off setting 1000ppm, adjustable to 0-200 ppm can be calibrated

FIGURE 8
Thermostat Connections

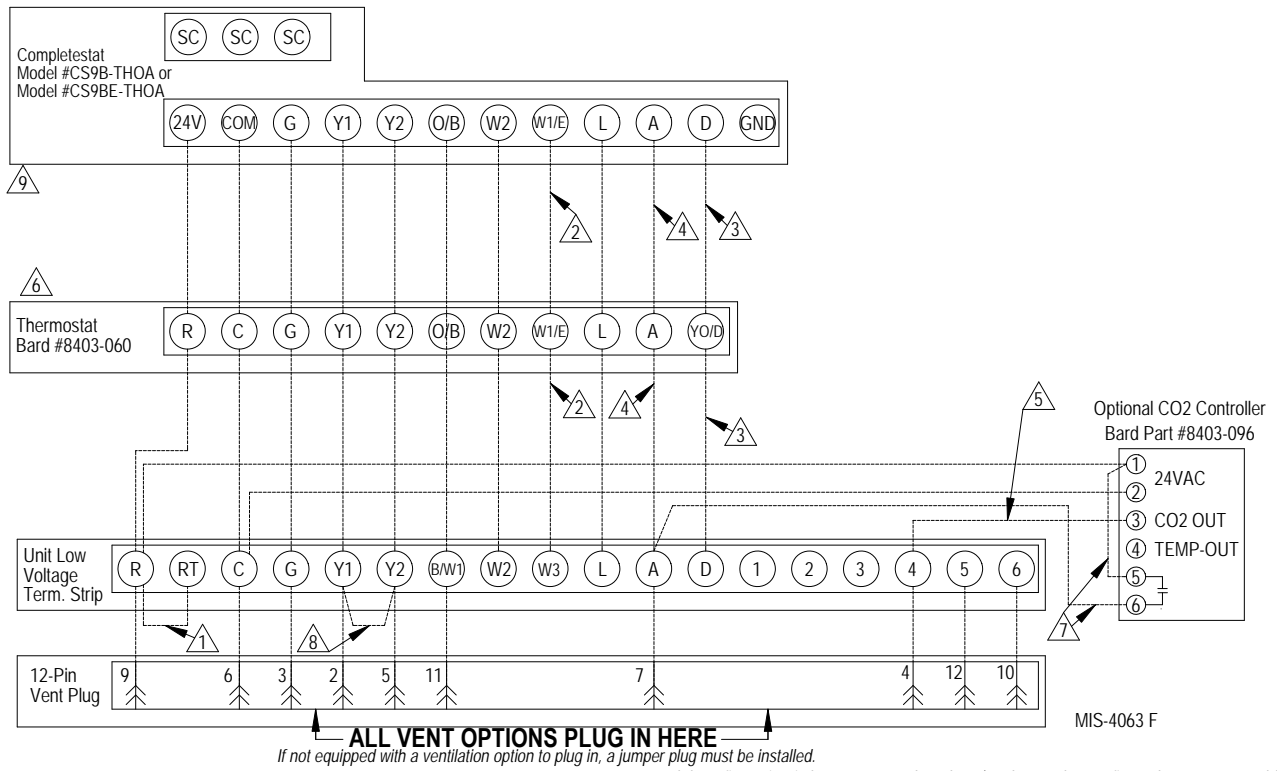

- 1 Factory installed jumper. Remove jumper and connect to N.C fire alarm circuit if emergency shutdown required.
- 2 Wire not needed below 15KW.
- 3 Wire required for dehumidification models only.
- 4 Do not connect "A" from thermostat if optional CO2 controller is used
- 5 0-10 VDC modulating CO2 control signal for modulating ventilation control (optional for ECON only - see vent instruction manuals)

- 6 Ensure model configuration is heat pump and not heat/cool. Must be configured to programmable and fan set to be programmed fan for the "A" output to function during scheduled occupied periods. Must be configured for multi-stage for Y1 output to be active 1st stage cooling. For dehumidification, must be configured for "No Economizer" for YO/D to be active for humidity control.
- 7 Do not add these wires if setting up for modulating control.
- 8 Factory installed jumper. Remove jumper to activate Balanced Climate™ Mode. A 2-stage thermostat is recommended for balanced climate mode. Y1 Y2 jumper not present if economizer is factory installed. Units with economizers have balanced climate jumper in economizer, refer to economizer manual. The jumper is factory removed in the unit and on jade for C**HY models.
- 9 Completestat not compatible with C**HY models.

FIGURE 9
Thermostat Connections

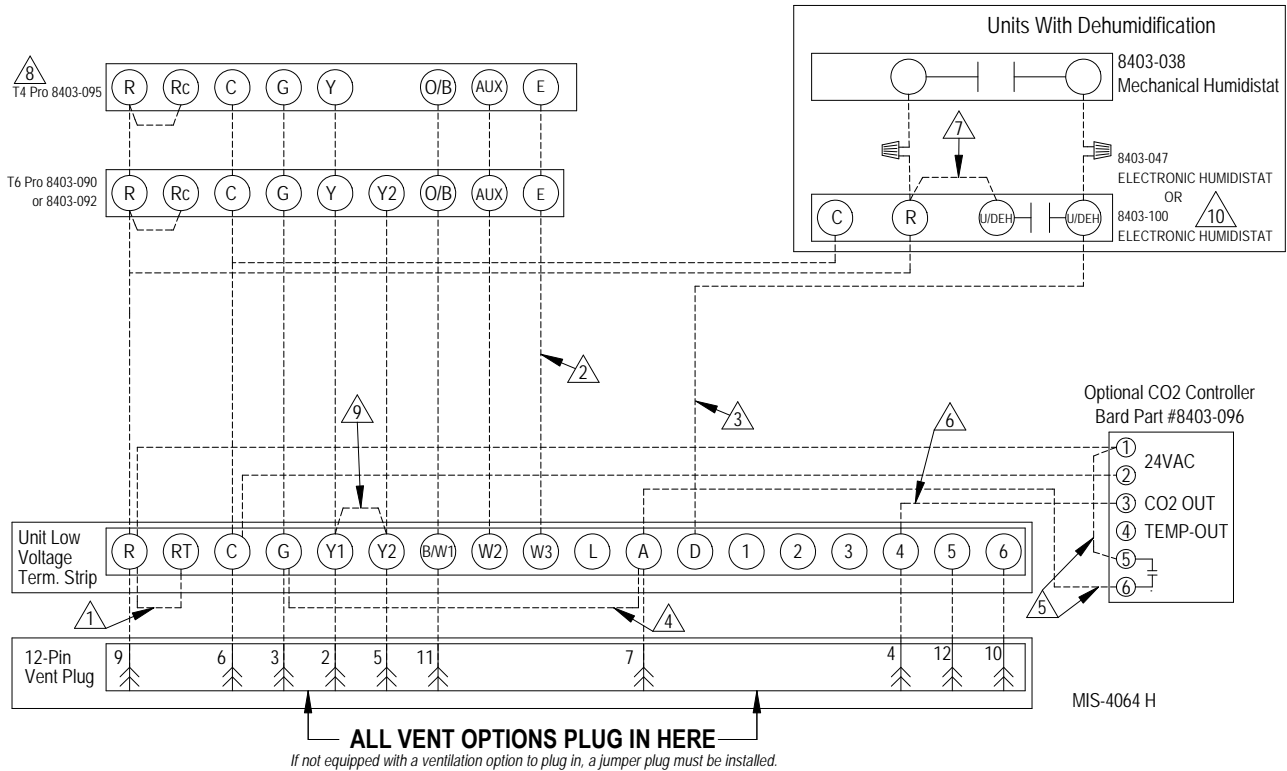

- ⚠️ **FACTORY INSTALLED JUMPER. REMOVE JUMPER AND CONNECT TO N.C FIRE ALARM CIRCUIT IF EMERGENCY SHUTDOWN REQUIRED.**
- ⚠️ **WIRE NOT NEEDED BELOW 15KW.**
- ⚠️ **WIRE REQUIRED FOR DEHUMIDIFICATION MODELS ONLY.**
- ⚠️ **FOR VENT OPERATION, ADD JUMPER IF OPTIONAL CO2 CONTROLLER IS NOT USED. VENT WILL RUN WHILE BLOWER IS ENERGIZED. FOR ECON & CRV-V, AN ADDITIONAL WIRE CHANGE IS REQUIRED. SEE INSTALL MANUAL.**
- ⚠️ **DO NOT ADD THESE WIRES IF SETTING UP FOR MODULATING CONTROL. SEE NOTE 6.**
- ⚠️ **0-10 VDC MODULATING CO2 CONTROL SIGNAL FOR MODULATING VENTILATION CONTROL (OPTIONAL FOR ECON ONLY) - SEE VENT INSTALLATION MANUAL.**
- ⚠️ **JUMPER NEEDS ADDED.**
- ⚠️ **THERMOSTAT WILL NOT WORK WITH UNITS EQUIPPED WITH ECONOMIZERS. T4 PRO NOT COMPATIBLE WITH C**HY MODELS**
- ⚠️ **FACTORY INSTALLED JUMPER. REMOVE JUMPER TO ACTIVATE BALANCED CLIMATE™ MODE. A 2-STAGE THERMOSTAT IS RECOMMENDED FOR BALANCED CLIMATE MODE. Y1 Y2 JUMPER NOT PRESENT IF ECONOMIZER IS FACTORY INSTALLED. UNITS WITH ECONOMIZERS HAVE BALANCED CLIMATE. JUMPER IN ECONOMIZER, REFER TO ECONOMIZER MANUAL. THE JUMPER IS FACTORY REMOVED IN THE UNIT AND ON JADE FOR C**HY MODELS**
- ⚠️ **HUMIDISTAT 8403-100 WILL NEED TO BE CONFIGURED FOR DEHUMIDIFICATION IN THE MENU. SEE USER'S MANUAL.**

NOTICE

These units require R-410A refrigerant and polyol ester oil.

General

1. Use separate service equipment to avoid cross contamination of oil and refrigerants.
2. Use recovery equipment rated for R-410A refrigerant.
3. Use manifold gauges rated for R-410A (800 psi/250 psi low).
4. R-410A is a binary blend of HFC-32 and HFC-125.
5. R-410A is nearly azeotropic—similar to R-22 and R-12. Although nearly azeotropic, charge with liquid refrigerant.
6. R-410A operates at 40-70% higher pressure than R-22 and systems designed for R-22 cannot withstand this higher pressure.
7. R-410A has an ozone depletion potential of zero, but must be reclaimed due to its global warming potential.
8. R-410A compressors use Polyol Ester oil.
9. Polyol Ester oil is hygroscopic; it will rapidly absorb moisture and strongly hold this moisture in the oil.
10. A liquid line dryer must be used—even a deep vacuum will not separate moisture from the oil.
11. Limit atmospheric exposure to 15 minutes.
12. If compressor removal is necessary, always plug compressor immediately after removal. Purge with small amount of nitrogen when inserting plugs.

Topping Off System Charge

If a leak has occurred in the system, Bard Manufacturing recommends reclaiming, evacuating (see criteria above) and charging to the nameplate charge. If done correctly, topping off the system charge can be done without problems.

With R-410A, there are no significant changes in the refrigerant composition during multiple leaks and recharges. R-410A refrigerant is close to being an azeotropic blend (it behaves like a pure compound or single component refrigerant). The remaining

refrigerant charge, in the system, may be used after leaks have occurred and then “top-off” the charge by utilizing the pressure charts on the inner control panel cover as a guideline.

REMEMBER: When adding R-410A refrigerant, it must come out of the charging cylinder/tank as a liquid to avoid any fractionation, and to ensure optimal system performance. Refer to instructions for the cylinder that is being utilized for proper method of liquid extraction.

WARNING

Failure to conform to these practices could lead to damage, injury or death.

Safety Practices

1. Never mix R-410A with other refrigerants.
2. Use gloves and safety glasses. Polyol Ester oils can be irritating to the skin and liquid refrigerant will freeze the skin.
3. Never use air and R-410A to leak check; the mixture may become flammable.
4. Do not inhale R-410A—the vapor attacks the nervous system, creating dizziness, loss of coordination and slurred speech. Cardiac irregularities, unconsciousness and ultimately death can result from breathing this concentration.
5. Do not burn R-410A. This decomposition produces hazardous vapors. Evacuate the area if exposed.
6. Use only cylinders rated DOT4BA/4BW 400.
7. Never fill cylinders over 80% of total capacity.
8. Store cylinders in a cool area, out of direct sunlight.
9. Never heat cylinders above 125°F.
10. Never trap liquid R-410A in manifold sets, gauge lines or cylinders. R-410A expands significantly at warmer temperatures. Once a cylinder or line is full of liquid, any further rise in temperature will cause it to burst.

Important Installer Note

For improved start-up performance, wash the indoor coil with dishwashing detergent.

High and Low Pressure Switch

All W**H Series wall-mounted heat pump models are supplied with a remote reset for the high and low pressure switch. If tripped, this pressure switch may be reset by turning the thermostat off then back on again.

Three Phase Scroll Compressor Start Up Information

Scroll compressors, like several other types of compressors, will only compress in one rotational direction. Direction of rotation is not an issue with single phase compressors since they will always start and run in the proper direction.

However, three phase compressors will rotate in either direction depending upon phasing of the power. Since there is a 50-50 chance of connecting power in such a way as to cause rotation in the reverse direction, verification of proper rotation must be made. Verification of proper rotation direction is made by observing that suction pressure drops and discharge pressure rises when the compressor is energized. Reverse rotation also results in an elevated sound level over that with correct rotation, as well as substantially reduced current draw compared to tabulated values.

Verification of **proper rotation** must be made at the time the equipment is put into service. If improper rotation is corrected at this time, there will be no negative impact on the durability of the compressor. However, reverse operation for over 1 hour may have a negative impact on the bearing due to oil pump out.

NOTE: *If compressor is allowed to run in reverse rotation for several minutes, the compressor's internal protector will trip.*

All three phase ZP compressors are wired identically internally. As a result, once the correct phasing is determined for a specific system or installation, connecting properly phased power leads to the same Fusite terminal should maintain proper rotation direction.

The direction of rotation of the compressor may be changed by reversing any two line connections to the unit.

Phase Monitor

All units with three phase scroll compressors are equipped with a three phase line monitor to prevent compressor damage due to phase reversal.

The phase monitor in this unit is equipped with two LEDs. If the Y signal is present at the phase monitor and phases are correct, the green LED will light.

If phases are reversed, the red fault LED will be lit and compressor operation is inhibited.

If a fault condition occurs, reverse two of the supply leads to the unit. **Do not reverse any of the unit factory wires as damage may occur.**

Condenser Fan Operation

NOTE: *Certain models may be equipped with a low ambient control (LAC), and if so, the condenser fan motor will have a delayed start until system refrigerant operating pressure builds up. After starting, the fan motor may or may not cycle depending upon ambient conditions. This is normal operation.*

Sequence of Operation

Cooling

Circuit R-Y1 makes at thermostat pulling in compressor contactor, starting the compressor and outdoor motor. (See **NOTE** under **Condenser Fan Operation** concerning models equipped with low ambient control.) The G (indoor motor) circuit is automatically completed on any call for cooling operation or can be energized by manual fan switch on subbase for constant air circulation.

Heating

A 24V solenoid coil on reversing valve controls heating cycle operation. Two thermostat options, one allowing "Auto" changeover from cycle to cycle and the other constantly energizing solenoid coil during heating season—thus eliminating pressure equalization noise except during defrost, are to be used.

On "Auto" option a circuit is completed from R-B/W1 and R-Y1 on each heating "on" cycle, energizing reversing valve solenoid and pulling in compressor contactor starting compressor and outdoor motor. R-G also make starting indoor blower motor. Heat pump heating cycle now in operation.

The second option has no "Auto" changeover position, but instead energizes the reversing valve solenoid constantly whenever the system switch on subbase is placed in "Heat" position, the "B" terminal being constantly energized from R. A thermostat demand for heat completes R-Y1 circuit, pulling in compressor contactor starting compressor and outdoor motor. R-G also make starting indoor blower motor.

On a call for 2nd stage heating, circuit R-W2 makes at the thermostat pulling in the heat contactor for the strip heat and blower operation. On a call for third stage heat, R-B/W1 breaks, dropping out heat pump, and R-W3 makes, bringing on second heat contactor, if so equipped.

Dehumidification and Electronic Expansion Valve (EEV)

For information on dehumidification and EEV operations, refer to latest version of dehumidification supplemental instructions 7960-828.

Balanced Climate™ Mode

Balanced Climate™ is a great comfort feature that can easily be applied under any normal circumstances. If the Bard heat pump system is being set up in a typical environment where 72°F is the lowest cooling setpoint, remove the Y1/Y2 jumper and install a 2-stage cooling

thermostat. This will increase the humidity removal up to 35% and provide a much more comfortable environment.

NOTE: *Units with mechanical dehumidification require an additional connection to be made when enabling Balanced Climate. Refer to dehumidification supplemental instructions for this step.*

This mode will also increase the supply temperature when in heating mode. When Balanced Climate mode is activated it is employed in both heating and cooling modes.

If the application is likely to require air conditioning operation below 60°F outdoor conditions, a low ambient control (LAC) kit must be installed. The LAC kit is equipped with an outdoor temperature switch that disables Balanced Climate mode when the outdoor temperature drops below 50°F. This prevents potential evaporator coil freeze up issues. The LAC kit also comes with an evaporator freeze protection thermostat that cuts out the compressor if the evaporator begins to freeze up.

If the unit is being installed with any ventilation package, a Bard LAC kit must be installed. Failure to utilize an LAC with any heat pump can cause coil freeze up.

Balanced Climate can readily be applied to duct-free (supply and return air grille) applications. It may also be applied to ducted applications with **limited static of 0.20" ESP (total including both supply and return statics)**. Consult Bard Application Engineering for details prior to implementation.

CAUTION: *Balanced Climate is not a replacement for a dehumidification (hot gas reheat) unit for extreme applications, but rather an enhancement feature for limited climates and applications.*

Defrost Cycle

The defrost cycle is controlled by temperature and time on the solid state heat pump control.

When the outdoor temperature is in the lower 40°F temperature range or colder, the outdoor coil temperature is 32°F or below. This coil temperature is sensed by the coil temperature sensor mounted near the bottom of the outdoor coil. Once coil temperature reaches 30°F or below, the coil temperature sensor sends a signal to the control logic of the heat pump control and the defrost timer will start accumulating run time.

After 30, 60 or 90 minutes of heat pump operation at 30°F or below, the heat pump control will place the system in the defrost mode.

During the defrost mode, the refrigerant cycle switches back to the cooling cycle, the outdoor motor stops, electric heaters are energized and hot gas passing through the outdoor coil melts any accumulated frost.

When the temperature rises to approximately 57°F, the coil temperature sensor will send a signal to the heat pump control which will return the system to heating operations automatically.

If some abnormal or temporary condition such as a high wind causes the heat pump to have a prolonged defrost cycle, the heat pump control will restore the system to heating operation automatically after 8 minutes.

The heat pump defrost control board has an option of 30-, 60- or 90-minute setting. By default, this unit is shipped from the factory with the defrost time on the 60-minute pin. If circumstances require a change to another time, remove the wire from the 60-minute terminal and reconnect to the desired terminal. Refer to Figure 10 on page 31.

There is a cycle speed up jumper on the control. This can be used for testing purposes to reduce the time between defrost cycle operation without waiting for time to elapse.

Use a small screwdriver or other metallic object, or another 1/4" QC, to short between the *SPEEDUP* terminals to accelerate the HPC timer and initiate defrost.

Be careful not to touch any other terminals with the instrument used to short the *SPEEDUP* terminals. It may take up to 10 seconds with the *SPEEDUP* terminals shorted for the speedup to be completed and the defrost cycle to start.

As soon as the defrost cycle kicks in, remove the shorting instrument from the SPEEDUP terminals. Otherwise the timing will remain accelerated and run through the 1-minute minimum defrost length sequence in a matter of seconds and will automatically terminate the defrost sequence.

There is an initiate defrost jumper (sen jump) on the control that can be used at any outdoor ambient during the heating cycle to simulate a 0°F coil temperature.

This can be used to check defrost operation of the unit without waiting for the outdoor ambient to fall into the defrost region.

By placing a jumper across the *SEN JMP* terminals (a 1/4" QC terminal works best) the defrost sensor mounted on the outdoor coil is shunted out and will activate the timing circuit. This permits the defrost cycle to be checked out in warmer weather conditions without the outdoor temperature having to fall into the defrost region.

In order to terminate the defrost test, the *SEN JMP* jumper must be removed. If left in place too long, the compressor could stop due to the high pressure control opening because of high pressure condition created by operating in the cooling mode with outdoor fan off. Pressure will rise fairly fast as there is likely no actual frost on the outdoor coil in this artificial test condition.

There is also a 5-minute compressor time delay function built into the HPC. This is to protect the compressor from short cycling conditions. The board's LED will have a fast blink rate when in the compressor time delay. In some instances, it is helpful to the service technician to override or speed up this timing period and shorting out the *SPEEDUP* terminals for a few seconds can do this.

Low Pressure Switch Bypass Operation

The control has a selectable (SW1) low pressure switch bypass set up to ignore the low pressure switch input during the first (30, 60, 120 or 180 seconds) of "Y" operation.

After this period expires, the control will then monitor the low pressure switch input normally to make sure that the switch is closed during "Y" operation.

High Pressure Switch Operation

The control has a built-in lockout system that allows the unit to have the high pressure switch trip up to two times in 1 hour and only encounter a "soft" lockout. A "soft" lockout shuts the compressor off and waits for the pressure switch to reset, which at that point then allows the compressor to be restarted as long as the 5-minute short cycle timer has run out. If the high pressure switch trips a third time within 1 hour, the unit is in "hard" lockout indicating something is certainly wrong and it will not restart itself.

Vent Connection Plug

All units are equipped with a vent connection plug in the side of the control panel for the different ventilation packages to plug in to. If the compressor will not start and there is no "Y1" at the defrost board, first check to make sure that either the optional vent is plugged into the vent connection plug or the supplied jumper plug is in place. **The unit will not operate without anything plugged in.** This plug is located on the side of the control panel behind the front vent door (behind the filter access door). If the unit is supplied with a factory-installed vent package, it will be plugged in but the jumper plug will also be tethered next to the connection for troubleshooting purposes, if necessary.

Pressure Service Ports

High and low pressure service ports are installed on all units so that the system operating pressures can be observed. Pressure tables covering all models can be found beginning on page 37. It is imperative to match the correct pressure table to the unit by model number.

This unit employs high-flow Coremax valves instead of the typical Schrader type valves.

WARNING! Do NOT use a Schrader valve core removal tool with these valves. Use of such a tool could result in eye injuries or refrigerant burns!

To change a Coremax valve without first removing the refrigerant, a special tool is required which can be obtained at www.fastestinc.com/en/SCCA07H. See the replacement parts manual for replacement core part numbers.

Service Hints

1. Caution owner/operator to maintain clean air filters at all times and to not needlessly close off supply and return air registers. This reduces airflow through the system, which shortens equipment service life as well as increasing operating costs.
2. Check all power fuses or circuit breakers to be sure they are the correct rating.
3. Periodic cleaning of the outdoor coil to permit full and unrestricted airflow circulation is essential.

FIGURE 10
Defrost Control Board

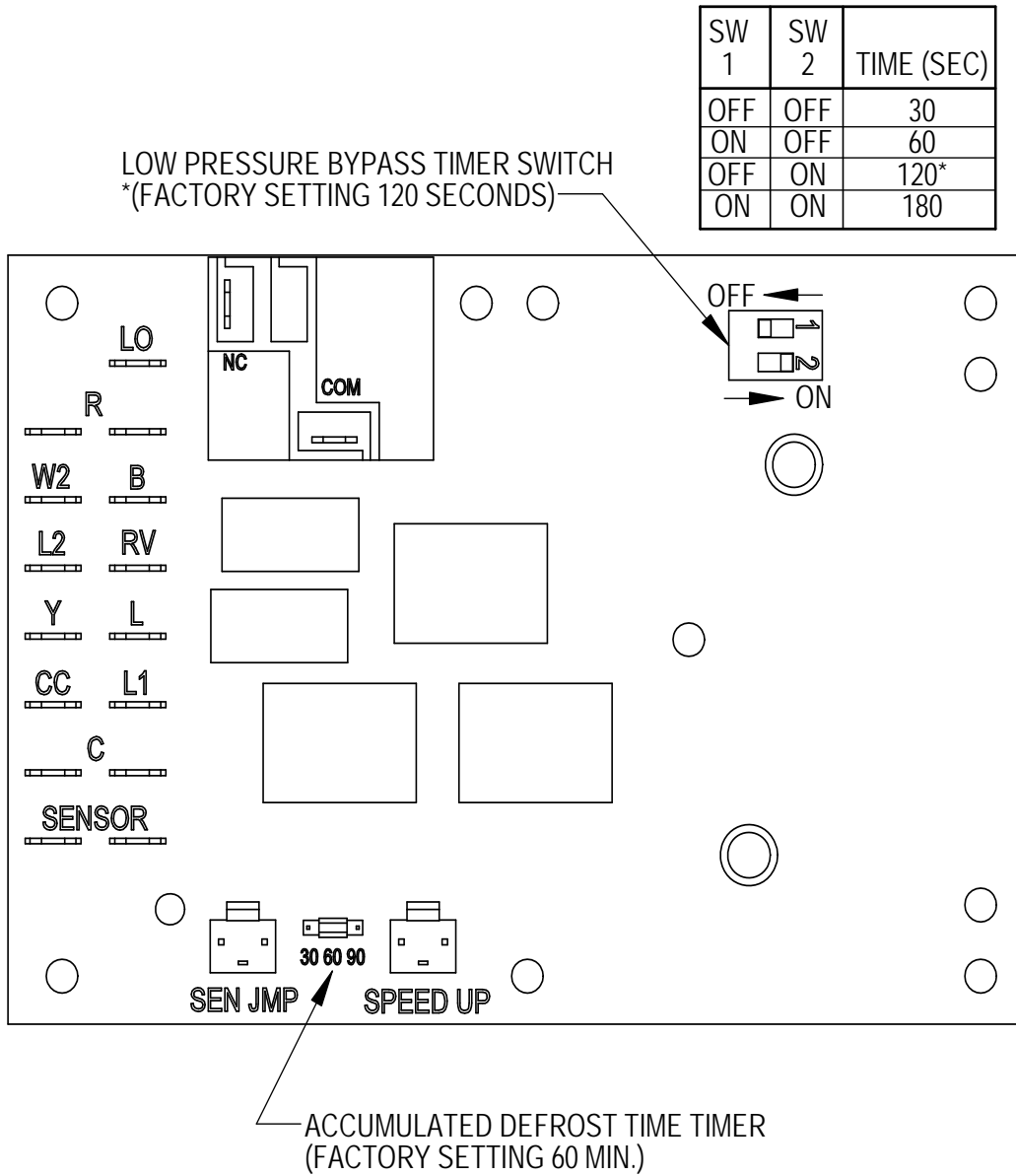

MIS-2668 A

Model	Setting
W18HY	60
W24HY	60
W30HY	60
W36HY	60

SERVICE

Solid State Heat Pump Control Troubleshooting Procedure

- NOTE:** A thorough understanding of the defrost cycle sequence is essential. Review that section (page 29) prior to troubleshooting the control. Turn on AC power supply to unit.
- Turn thermostat blower switch to “fan on”—the indoor blower should start. (If it doesn't, troubleshoot indoor unit and correct problem.)
- Turn thermostat blower to “auto” position. Indoor blower should stop. **NOTE:** Many models have a 1-minute blower time delay on “off” command; wait for this to time out.
- Set system switch to “heat” or “cool”. Adjust thermostat to call for heat or cool. The indoor blower, compressor and outdoor fan should start.

NOTE: If there was no power to 24 volt transformer, the compressor and outdoor fan motor will not start for 5 minutes. This is because of the compressor short cycle protection.

LED Blink Codes	
Blink	Function
Slow	Normal function (1.0 sec on/1.0 sec off)
Fast	Compressor Delay timer active (0.1 sec on/0.1 sec off)
1	Low pressure switch failure
2	High pressure switch failure/“Soft” Lockout
3	Defrost mode active
4	High pressure switch failure/“Hard” Lockout

TABLE 8 – Troubleshooting

Symptom	Description, Check and Possible Causes	What & How to Check / Repair
Compressor will not start (heating or cooling)	1. Check for LED illumination. Is there an LED illuminated on the board (flashing)?	Yes = go to Step #2; No = go to Step #3
	2. Check for error codes. Is the LED flashing a Code?	Yes = go to Step #4; No = go to Step #8
	3. Check for power at board. Is there 24 volts AC between R and C?	Yes = go to Step #13; No = go to Step #9
	4. Check codes. What code is blinking?	Code "1", go to Step #6; Code "2", go to Step#7; Fast Blink, go to Step #5
	5. Compressor delay active. Wait for 5 minute delay or jump board's "speed up pins".	Check for proper operation; if still needed, go back to Step #1.
	6. Low pressure fault.	Check wiring circuit and unit pressures.
	7. High pressure fault.	Check wiring circuit and unit pressures.
	8. Check for Compressor input signal. Is there 24 volts AC between Y and C?	Yes = go to Step #10; No = go to Step #11
	9. No power to board.	The unit either does not have unit voltage, the transformer is bad or the unit wiring is incorrect.
	10. Check for Compressor output signal. Is there 24 volts AC between CC & C?	Yes = go to Step #12; No = go to Step #13
	11. No "Y" compressor input signal.	Check thermostat wiring, incorrect phase of unit (see section on Phase Monitor), and finally unit wiring.
	12. No "CC" compressor output signal.	Check compressor contactor for proper operation and finally check compressor.
	13. Faulty board.	Replace defrost board.
Fan outdoor motor does not run (cooling or heating except during defrost)	Heat pump control defective	Check across fan relay on heat pump control. (Com-NC) Replace heat pump control.
	Motor defective	Check for open or shorted motor winding. Replace motor.
	Motor capacitor defective	Check capacitor rating. Check for open or shorted capacitor. Replace capacitor.
Reversing valve does not energize (heating only)	Heat pump control defective	Check for 24V between RV-C and B-C. 1. Check control circuit wiring. 2. Replace heat pump control.
	Reversing valve solenoid coil defective	Check for open or shorted coil. Replace solenoid coil.
Unit will not go into defrost (heating only)	Temperature sensor or heat pump control defective	Disconnect temperature sensor from board and jumper across "SPEEDUP" terminals and "SEN JMP" terminals. This should cause the unit to go through a defrost cycle within one minute. 1. If unit goes through defrost cycle, replace temperature sensor. 2. If unit does not go through defrost cycle, replace heat pump control.
Unit will not come out of defrost (heating only)	Temperature sensor or heat pump control defective	Jumper across "SPEEDUP" terminal. This should cause the unit to come out of defrost within one minute. 1. If unit comes out of defrost cycle, replace temperature sensor. 2. If unit does not come out of defrost cycle, replace heat pump control.

Checking Temperature Sensor Outside Unit Circuit

1. Disconnect temperature sensor from board and from outdoor coil.
2. Use an ohmmeter to measure the resistance of the sensor. Also use ohmmeter to check for short or open.
3. Check resistance reading to chart of resistance. Use sensor ambient temperature. (Tolerance of part is $\pm 10\%$.)
4. If sensor resistance reads very low, sensor is shorted and will not allow proper operation of the heat pump control.
5. If sensor is out of tolerance, shorted, open or reads very low ohms, it should be replaced.

TABLE 9
Temperature F vs. Resistance R of Temperature Sensor

F	R	F	R	F	R	F	R
-25.0	196871	13.0	56985	53.0	19374	89.0	7507
-24.0	190099	14.0	55284	52.0	18867	90.0	7334
-23.0	183585	15.0	53640	53.0	18375	91.0	7165
-22.0	177318	16.0	52051	54.0	17989	92.0	7000
-21.0	171289	17.0	50514	55.0	17434	93.0	6840
-20.0	165487	18.0	49028	56.0	16984	94.0	6683
-19.0	159904	19.0	47590	57.0	16547	95.0	6531
-18.0	154529	20.0	46200	58.0	16122	96.0	6383
-17.0	149355	21.0	44855	59.0	15710	97.0	6239
-16.0	144374	22.0	43554	60.0	15310	98.0	6098
-15.0	139576	23.0	42295	61.0	14921	99.0	5961
-14.0	134956	24.0	41077	62.0	14544	100.0	5827
-13.0	130506	25.0	39898	63.0	14177	101.0	5697
-12.0	126219	26.0	38757	64.0	13820	102.0	5570
-11.0	122089	27.0	37652	65.0	13474	103.0	5446
-10.0	118108	28.0	36583	66.0	13137	104.0	5326
-9.0	114272	29.0	35548	67.0	12810	105.0	5208
-8.0	110575	30.0	34545	68.0	12492	106.0	5094
-7.0	107010	31.0	33574	69.0	12183	107.0	4982
-6.0	103574	32.0	32634	70.0	11883	108.0	4873
-5.0	100260	33.0	31723	71.0	11591	109.0	4767
-4.0	97064	34.0	30840	72.0	11307	110.0	4663
-3.0	93981	35.0	29986	73.0	11031	111.0	4562
-2.0	91008	36.0	29157	74.0	10762	112.0	4464
-1.0	88139	37.0	28355	75.0	10501	113.0	4367
0.0	85371	38.0	27577	76.0	10247	114.0	4274
1.0	82699	39.0	26823	77.0	10000	115.0	4182
2.0	80121	40.0	26092	78.0	9760	116.0	4093
3.0	77632	41.0	25383	79.0	9526	117.0	4006
4.0	75230	42.0	24696	80.0	9299	118.0	3921
5.0	72910	43.0	24030	81.0	9077	119.0	3838
6.0	70670	44.0	23384	82.0	8862	120.0	3757
7.0	68507	45.0	22758	83.0	8653	121.0	3678
8.0	66418	46.0	22150	84.0	8449	122.0	3601
9.0	64399	47.0	21561	85.0	8250	123.0	3526
10.0	62449	48.0	20989	86.0	8057	124.0	3452
11.0	60565	49.0	20435	87.0	7869		
12.0	58745	50.0	19896	88.0	7686		

Troubleshooting Nidec SelecTech Series ECM Motors

If the Motor Is Running

1. It is normal for the motor to rock back and forth on start up. Do not replace the motor if this is the only problem identified.
2. If the system is excessively noisy, does not appear to change speeds in response to a demand (Heat, Cool, Other) or is having symptoms during the cycle such as tripping limit or freezing coil, check the following:
 - A. Wait for programmed delays to time out.
 - B. Ensure that the motors control inputs are wired as shown in the factory-supplied wiring diagram to ensure motor is getting proper control signals and sequencing.
 - C. Remove the filter and check that all dampers, registers and grilles are open and free flowing. If removing the filters corrects the problem, clean or replace with a less restrictive filter. Also check and clean the blower wheel or coil as necessary.
 - D. Check the external static pressure (total of both supply and return) to ensure it is within the range as listed on the unit serial plate. If

higher than allowed, additional duct work is needed.

- E. If the motor does not shut off at the end of the cycle, wait for any programmed delays to time out (no more than 90 seconds). Also make sure that there is no call for "Continuous Fan" on the "G" terminal.
- F. If the above diagnostics do not solve the problem, confirm the voltage checks in the next section below, then continue with the "Model SelecTech Communication Diagnostics".

If the Motor Is Not Running

1. Check for proper high voltage and ground at the (L/L1) (G) (N/L2) connections at the motor (see Figure 11). Correct any voltage issues before proceeding to the next step. The SelecTech motor is voltage specific. Only the correct voltage should be applied to the proper motor. Input voltage within plus or minus 10% of the nominal line power VAC is acceptable.
2. If the motor has proper high voltage and ground at the (L/L1) (G) (N/L2) connections, then continue to "Model SelecTech Communication Diagnostics".

FIGURE 11
Motor Connections

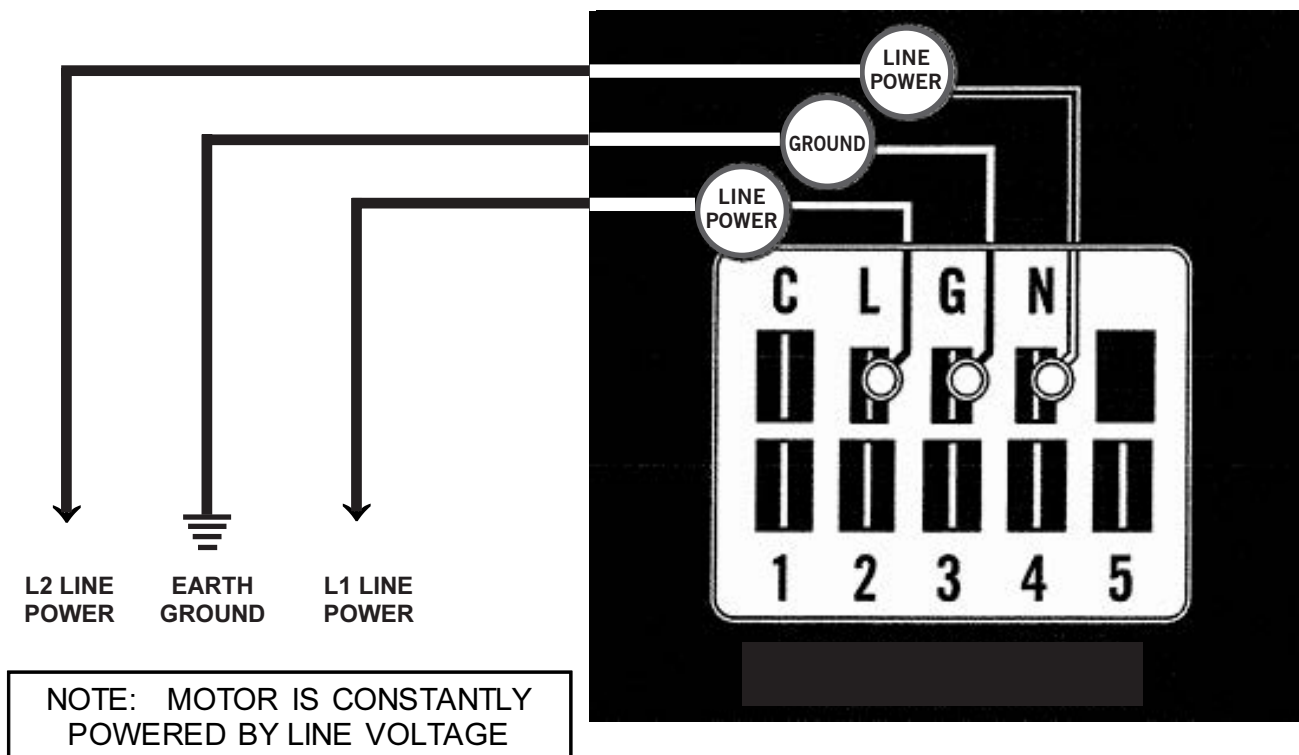

Model SelecTech Communication Diagnostics

The SelecTech motor is communicated through 24 VAC low voltage (thermostat control circuit wiring).

1. Start with unit wiring diagram to confirm proper connections and voltage (see Figure 12).
2. Initiate a demand from the thermostat and check the voltage between the common and the appropriate motor terminal (1-5). ("G" input is typically on terminal #1, but always refer to wiring diagram.)
 - A. If the low voltage communication is not present, check the demand from the thermostat. Also check the output terminal and wire(s) from the terminal strip or control relay(s) to the motor.

- B. If the motor has proper high voltage as identified above (**If the Motor Is Not Running #1**), proper low voltage to a programmed terminal and is not operating, the motor has failed and will require replacement.

FIGURE 12
Motor Connections

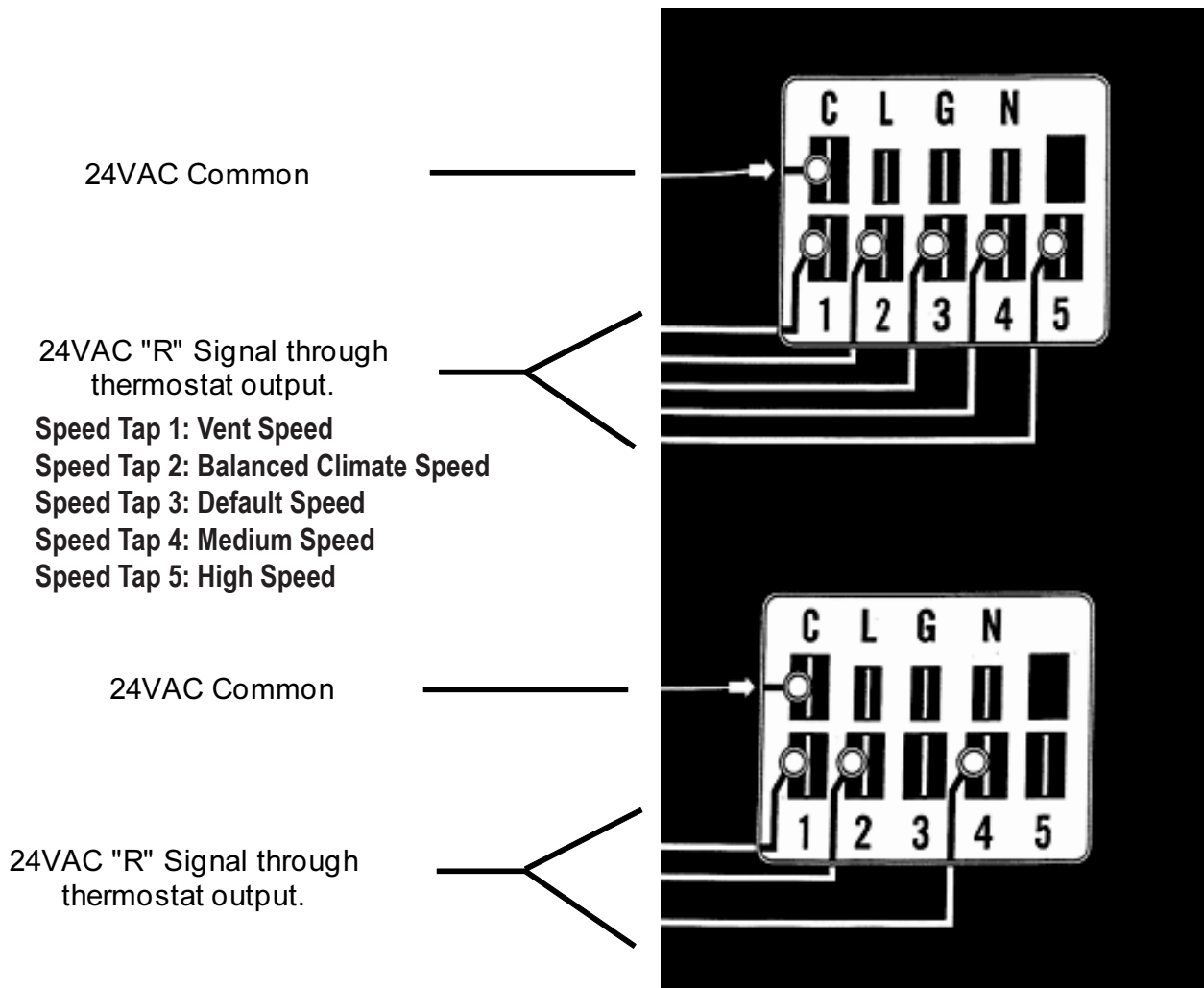

Fan Blade Setting Dimensions

The correct fan blade setting for proper air delivery across the outdoor coil is shown in Figure 13. Refer to Table 10 for unit specific dimension.

Any service work requiring removal or adjustment in the fan and/or motor area will require that the dimensions below be checked and blade adjusted in or out on the motor shaft accordingly.

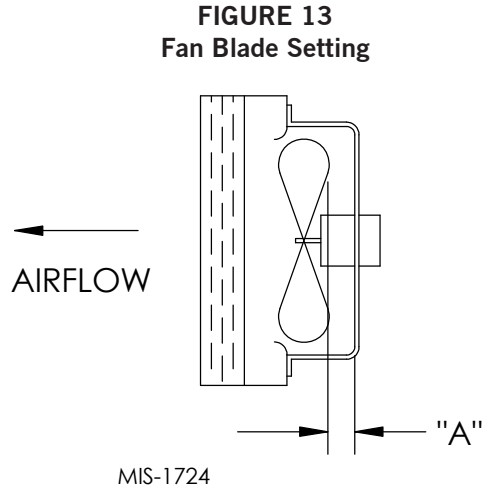

TABLE 10
Fan Blade Dimension

Model	Dimension A
W18HY	1.00"
W24HY	0.75"
W30HY W36HY	1.25"

Removal of Fan Shroud

1. Disconnect all power to the unit.
2. Remove the screws holding both grilles, one on each side of unit, and remove grilles.
3. Remove nine screws holding fan shroud to condenser and bottom.
4. Unwire condenser fan motor.
5. Slide complete motor, fan blade and shroud assembly out the left side of the unit.
6. Service motor/fan as needed.
7. Reverse steps to re-install.

R-410A Refrigerant Charge

This unit was charged at the factory with the quantity of refrigerant listed on the serial plate. AHRI capacity and efficiency ratings were determined by testing with this refrigerant charge quantity.

The pressure tables on the following pages show nominal pressures for the units. Since many installation specific situations can affect the pressure readings, this information should only be used by certified technicians as a guide for evaluating proper system performance. They shall not be used to adjust charge. If charge is in doubt, reclaim, evacuate and recharge the unit to the serial plate charge.

TABLE 11A
Cooling Pressure

Air Temperature Entering Outdoor Coil °F

Model	Return Air Temp (DB/WB)	Pressure	75	80	85	90	95	100	105	110	115	120	125	131
W18HY	75/62	Low Side	124	126	129	131	133	136	138	140	142	144	146	149
		High Side	294	315	337	359	383	408	434	461	488	517	546	583
	80/67	Low Side	132	135	138	140	143	145	147	150	152	154	157	159
		High Side	301	323	345	369	393	419	445	472	501	530	560	598
	85/72	Low Side	137	140	142	145	148	150	153	155	157	160	162	165
		High Side	312	334	357	382	407	433	461	489	518	548	580	619
W24HY	75/62	Low Side	121	125	128	131	133	135	137	139	141	142	143	144
		High Side	298	319	341	365	389	414	440	467	495	524	554	591
	80/67	Low Side	130	133	137	140	142	145	147	149	151	152	153	154
		High Side	306	328	350	374	399	424	451	479	508	537	568	606
	85/72	Low Side	134	138	141	145	147	150	152	154	156	157	159	160
		High Side	317	339	363	387	413	439	467	496	525	556	588	628
W30HY	75/62	Low Side	133	135	136	138	139	141	143	144	146	148	150	153
		High Side	320	337	356	377	400	426	453	482	513	547	582	627
	80/67	Low Side	143	144	146	147	149	151	152	154	156	158	161	163
		High Side	328	346	365	387	411	437	465	495	527	561	597	644
	85/72	Low Side	148	149	151	152	154	156	158	160	162	164	166	--*
		High Side	340	358	378	400	425	452	481	512	545	581	618	--*
W36HY	75/62	Low Side	129	131	133	135	137	139	140	142	144	145	147	148
		High Side	322	344	366	390	414	440	466	493	522	552	582	620
	80/67	Low Side	138	140	142	145	146	148	150	152	154	155	157	159
		High Side	330	352	375	400	425	451	478	506	535	566	597	636
	85/72	Low Side	143	145	147	150	152	154	156	157	159	161	162	--*
		High Side	342	365	389	414	440	467	495	524	554	585	618	--*

Low side pressure ± 4 PSIG
High side pressure ± 10 PSIG

Tables are based upon rated CFM (airflow) across the evaporator coil. If there is any doubt as to correct operating charge being in the system, the charge should be removed and system evacuated and recharged to serial plate charge weight.

NOTE: Pressure table based on high speed condenser fan operation. If condensing pressures appear elevated check condenser fan wiring. See **Condenser Fan Operation** on page 28.

* Operating at these conditions would be outside the compressor operating envelope and is not recommended.

TABLE 11B
Heating Pressure

Air Temperature Entering Outdoor Coil °F

Model	Indoor	Heating	0	5	10	15	17	20	25	30	35	40	45	47	50	55	60	65
W18HY	70	Suction Pressure	41.70	48.00	54.50	61.20	64.00	68.20	75.40	82.90	90.70	98.60	106.90	110.20	115.30	124.00	133.00	142.20
		Head Pressure	243.00	250.20	257.70	265.40	268.50	273.30	281.40	289.80	298.40	307.20	316.20	319.90	325.50	335.00	344.70	354.70
W24HY	70	Suction Pressure	39.10	45.10	51.30	57.70	60.40	64.40	71.40	78.60	86.10	93.80	101.80	105.10	110.10	118.60	127.40	136.40
		Head Pressure	255.50	264.90	274.30	283.60	287.30	292.90	302.10	311.30	320.50	329.70	338.80	342.40	347.80	356.90	365.90	374.80
W30HY	70	Suction Pressure	39.40	45.50	51.80	58.40	61.00	65.10	72.00	79.10	86.50	94.00	101.70	104.90	109.70	117.80	126.20	134.70
		Head Pressure	254.60	260.70	267.10	273.70	276.40	280.60	287.70	295.10	302.80	310.70	318.90	322.20	327.30	336.00	344.90	354.20
W36HY	70	Suction Pressure	39.50	44.80	50.40	56.30	58.50	62.50	69.00	75.80	82.90	90.30	98.00	101.20	106.00	114.30	122.90	131.70
		Head Pressure	289.40	293.90	298.90	304.60	307.10	310.90	317.80	325.40	333.50	342.20	351.60	355.50	361.50	372.10	383.30	395.10

TABLE 12
Cooling Pressure – Balanced Climate Airflow

Air Temperature Entering Outdoor Coil °F

Model	Return Air Temp (DB/WB)	Pressure	75	80	85	90	95	100	105	110	115	120	125	131
W18HY	75/62	Low Side	113	119	123	127	131	134	136	138	139	140	140	140
		High Side	285	308	331	355	380	405	431	457	484	512	540	574
	80/67	Low Side	121	127	132	136	140	143	145	147	149	150	150	149
		High Side	292	316	340	365	390	416	442	469	497	525	553	589
	85/72	Low Side	125	131	136	141	145	148	151	153	154	155	155	155
		High Side	302	327	352	377	403	430	458	486	514	543	573	609
W24HY	75/62	Low Side	116	118	121	123	125	127	129	131	133	134	136	138
		High Side	294	314	336	359	382	406	431	457	484	512	541	577
	80/67	Low Side	124	126	129	131	134	136	138	140	142	144	145	147
		High Side	301	323	345	368	392	417	442	469	497	525	555	592
	85/72	Low Side	128	131	133	136	138	141	143	145	147	149	151	153
		High Side	312	334	357	381	405	431	458	486	514	544	574	612
W30HY	75/62	Low Side	125	127	129	131	133	135	137	138	140	142	144	146
		High Side	308	327	348	370	395	420	447	476	507	539	573	615
	80/67	Low Side	134	136	138	140	142	144	146	148	150	152	154	156
		High Side	316	336	357	380	405	431	459	489	520	553	587	631
	85/72	Low Side	139	141	143	145	147	149	151	153	155	157	159	--*
		High Side	327	348	370	393	419	446	475	506	538	572	608	
W36HY	75/62	Low Side	122	124	126	128	129	131	133	134	136	137	138	140
		High Side	312	335	358	381	405	429	454	479	504	530	556	588
	80/67	Low Side	131	133	135	137	138	140	142	144	145	147	148	150
		High Side	320	343	367	391	415	440	465	491	517	544	570	603
	85/72	Low Side	135	137	139	141	143	145	147	149	150	152	153	155
		High Side	331	355	380	405	430	456	482	508	535	563	590	624

Low side pressure ± 4 PSIG
High side pressure ± 10 PSIG

Tables are based upon Balanced Climate CFM (airflow) across the evaporator coil. If there is any doubt as to correct operating charge being in the system, the charge should be removed and system evacuated and recharged to serial plate charge weight.

NOTE: Pressure table based on high speed condenser fan operation. If condensing pressures appear elevated check condenser fan wiring. See **Condenser Fan Operation** on page 28.

* Operating at these conditions would be outside the compressor operating envelope and is not recommended.

TABLE 13
Electrical Specifications

Model	Rated Volts & Phase	No. Field Power Circuits	Single Circuit		Dual Circuit			
			① Minimum Circuit Ampacity	② Maximum External Fuse or Circuit Breaker	① Minimum Circuit Ampacity		② Maximum External Fuse or Circuit Breaker	
					Ckt. A	Ckt. B	Ckt. A	Ckt. B
W18HY-A00, A0Z A04 A08	230/208-1	1 1 1	16 37 58	20 40 60				
W24HY-A00, A0Z A04 A08	230/208-1	1 1 1 or 2	22 43 63	25 45 70	22	42	25	45
W24HY-B00, B0Z B05	230/208-3	1 1	15 30	20 30				
W24HY-C00, C0Z C05	460-3	1 1	8 15	15 15				
W30HY-A00, A0Z A05 A10	230/208-1	1 1 1 or 2	24 50 76	30 50 80	24	52	30	60
W30HY-B00, B0Z B05 B09	230/208-3	1 1 1	17 32 44	20 35 45				
W30HY-C00, C0Z C05 C09	460-3	1 1 1	9 16 22	15 20 25				
W36HY-A00, A0Z A05 A10 ③ A15	230/208-1	1 1 1 or 2 1 or 2	27 53 79 84	35 60 80 90	27 32	52 52	35 35	60 60
W36HY-B00, B0Z B05 B09	230/208-3	1 1 1	20 35 47	25 35 50				
W36HY-C00, C0Z C05 C09	460-3	1 1 1	11 18 24	15 20 25				

① These "Minimum Circuit Ampacity" values are to be used for sizing the field power conductors. Refer to the National Electrical code (latest version), Article 310 for power conductor sizing. **CAUTION:** When more than one field power circuit is run through one conduit, the conductors must be derated. Pay special attention to note 8 of Table 310 regarding Ampacity Adjustment Factors when more than three (3) current carrying conductors are in a raceway.

② Maximum size of the time delay fuse or circuit breaker for protection of field wiring conductors.

③ Maximum KW that can operate with the heat pump on is 10KW. Full heat available during emergency heat mode.

NOTE: The Maximum Overcurrent Protection (MOCP) value listed is the maximum value as per UL 60335 calculations for MOCP (branch-circuit conductor sizes in this chart are based on this MOCP). The actual factory-installed overcurrent protective device (circuit breaker) in this model may be lower than the maximum UL 60335 allowable MOCP value, but still above the UL 60335 minimum calculated value or Minimum Circuit Ampacity (MCA) listed.

IMPORTANT: While this electrical data is presented as a guide, it is important to electrically connect properly sized fuses and conductor wires in accordance with the National Electrical Code and all local codes.

Setting Unit Airflow

The unit is set from the factory at the default speed. Most units have three selectable cooling speed taps that can be utilized. The default speed is the lowest cooling speed. The two higher speed taps can be used for higher duct static applications so that the unit can maintain the recommended airflow as shown in Table 14. The higher speeds can also be used when higher sensible cooling is desired. To change to the higher speed taps, move the orange/black wire on the blower speed terminal block to either MED or HI. Refer to Table 16 on page 44 for the corresponding airflow of each tap. Set the unit duct static based on the highest airflow that the unit will run at.

TABLE 14
Recommended Airflow

Model	Nominal Rated CFM*	Nominal Rated ESP*	Recommended Airflow Range	Factory Speed Connection
W18HY	600	.10	550 - 725	Default
W24HY	800	.10	700 - 950	Default
W30HY	1000	.15	900 - 1125	Default
W36HY	1100	.15	1000 - 1200	Default

* Rated CFM and ESP on factory speed connection.

NOTE: Be sure to adjust the system static or blower speed to maintain airflows above the minimum recommendations to prevent freeze up conditions if Balanced Climate mode is activated.

Do not operate the unit in Balanced Climate mode if running high static applications as indicated in the blower performance table. If Balanced Climate mode is activated as described on page 23, the unit will run in this mode at all times unless there is a call for ventilation, electric heat or 2nd stage cooling from a 2-stage thermostat. At that time, the unit will automatically activate a higher speed tap.

Blower Speeds

Five factory programmed speed taps (torque settings) are available for the motor, and are selected through different unit modes of operation. These modes are energized by 24VAC signals from the low voltage terminal block located inside the control panel by a thermostat or other controlling device. Each speed tap is programmed by Bard at the factory to different motor torque settings (see Figure 14).

FIGURE 14
Speed Taps

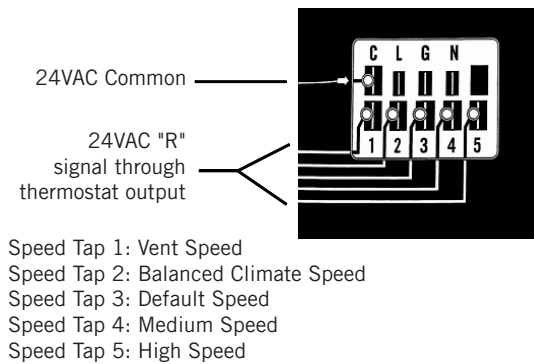

Multiple motor speed taps may be energized simultaneously by 24VAC power during different modes of operation. The highest number speed tap energized takes priority with 5 being the highest and 1 being the lowest. See Table 15 for the corresponding blower speeds with the different modes of operation.

Programmed blower speed taps are as follows (see also Figure 15):

Speed Tap 1: **Vent/blower only** speed

Speed Tap 2: **Balanced Climate** speed

Speed Tap 3: **Default LO cooling & heating** speed. Energized by default for cooling operation through the blower speed tap selection and is labeled as LO.

Speed Tap 4: **Optional MED Cooling & heating** speed. Selected manually through the blower speed tap selection and is labeled as MED.

Speed Tap 5: **Optional HI cooling & heating** speed. Selected manually through the blower speed tap selection and is labeled as HI.

FIGURE 15
Speed Taps

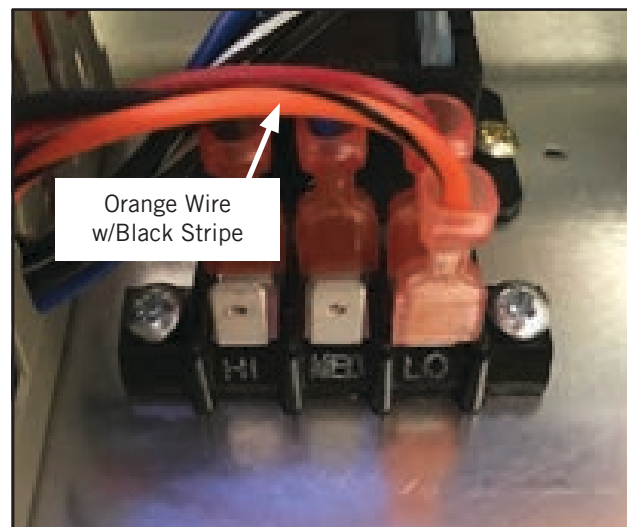

TABLE 15
Blower Speeds for Unit Operational Modes

Unit Operation	Thermostat Inputs – 24VAC							Speed Taps			Blower Speed	Compressor Operation
	G	Y1	Y2	B/W1	W2	W3	D	1	2	3-4-5 ¹		
Blower Only	X							X			Vent/Blower Only	Off
Balanced Climate Cooling	X	X						X	X		Balanced Climate	On
Full Load Cool	X	X	X					X	X	X	Lo/Med/Hi	On
Balanced Climate Heat Pump Heating	X	X		X				X	X		Balanced Climate	On
Full Load Heat Pump Heating	X	X	X	X				X	X	X	Lo/Med/Hi	On
1st Stage Electric Heat					X					X	Lo/Med/Hi	Off
2nd Stage Electric Heat					X	X				X	Lo/Med/Hi	Off
Dehumidify ²							X	X	X		Balanced Climate	On

¹ Fan speed is selectable through the blower speed control terminal block. LO (default), MED or HI speeds can be used.

² Dehumidification operation is disabled when a call for heating or cooling occurs. Unit runs at Balanced Climate speed during dehumidification operation.

Speed Tap 1 – Vent/Blower Only

Speed taps 1 and 3 are programmed to identical torque settings in the ECM motor. This means that if speed tap 1 is energized, the airflow amount will be the same as default airflow. Tap 1 is used when a vent is installed and ventilation is called for by energizing the A terminal of the low voltage terminal block with 24VAC. Speed tap 1 is the lowest priority; if any of the other speed taps are energized, they will override speed tap 1.

Speed Tap 2 – Balanced Climate

Speed tap 2 is programmed to a lower than rated speed in the ECM motor. In order for Balanced Climate speed to be used during compressor cooling mode, the jumper between Y1 and Y2 must be removed. This means that if speed tap 2 is energized, the airflow amount will be lower than default airflow. Tap 2 is used when Balanced Climate is called for by energizing the Y1 terminal of the low voltage terminal block with 24VAC. Speed tap 2 is overridden if taps 3, 4, or 5 are energized.

Speed Tap 3 – Default LO Cooling & Heating

Speed tap 3 is programmed for rated speed in the SelecTech motor. This means that if speed tap 3 is energized, the airflow amount will be the default airflow. Tap 3 is used by default when cooling is called for by energizing the Y1 terminal of the low voltage terminal block with 24VAC. The unit is shipped with

the jumper between Y1 and Y2 installed and it must be removed to use Balanced Climate mode. The unit is shipped with the orange/black wire connected to terminal LO (rated speed) on the blower selection speed terminal block. Speed tap 3 can be overridden if taps 4 or 5 are energized by changing the position of the orange/black wire on the blower selection speed terminal block to MED (4) or HI (5) positions.

Speed Tap 4 – Optional MED Cooling & Heating

Speed tap 4 is programmed to a higher than rated speed in the ECM motor. This is a user-selectable airflow amount that will be higher than rated airflow. Tap 4 is used for cooling operation if the orange/black wire on the blower speed selection terminal block is moved to MED. Speed tap 4 can be overridden if tap 5 is energized.

Speed Tap 5 – Optional HI Cooling & Heating

Speed tap 5 is programmed to the highest speed in the ECM motor. This is a user-selectable airflow amount that will provide the highest rated airflow. Tap 5 is used for cooling operation if the orange/black wire on the blower speed selection terminal block is moved to HI.

Dirty Filter Switch

1. Disconnect all power to the unit. Remove control panel outer cover and upper front panel.
2. The dirty filter switch is located on top of the filter partition to the right of the blower wheels (see Figure 16). The dirty filter indicator light and reset switch is attached to the side of the control panel on the right side of the filter access opening. Remove the cover on the dirty filter switch and ensure the knob is set at 0.4" W.C. (see Figure 17). This is only a recommended starting point prior to making switch adjustments. Switch setting is highly dependent on filter type used, blower speed, unit ducting and other unit installation characteristics. See **Dirty Filter Switch Adjustment** for instructions on how to make proper switch adjustments.
3. Re-install upper front panel.

Dirty Filter Switch Adjustment

1. Apply power to the unit.
2. Turn the unit indoor blower on (energize R-G on low voltage terminal board).

3. With air filters installed and switch initially set at 0.4" W.C. (see Step 2 under **Dirty Filter Switch**), begin restricting the air filter of the unit using a piece of cardboard under the filters until the switch trips and the light comes on. If the filter is restricted by 75% (or desired restriction amount), skip to Step 6.
4. If switch setting adjustment is required, disconnect power to the unit. Remove the upper front panel and the cover on the airflow switch so that adjustment can be made. If the switch tripped before 75% restriction was reached, turn the knob slightly clockwise. If the switch tripped after 75%, turn the knob counter-clockwise (see Figure 17).
5. Replace the upper front panel and repeat Steps 1-3. Continue to make adjustments described in Step 4 until the desired restriction is obtained.
6. Remove the restriction and reset the filter switch. Replace the switch cover once adjustment is complete.
7. Install the outer control panel cover. This completes the adjustment.

FIGURE 16
Dirty Filter Switch Location

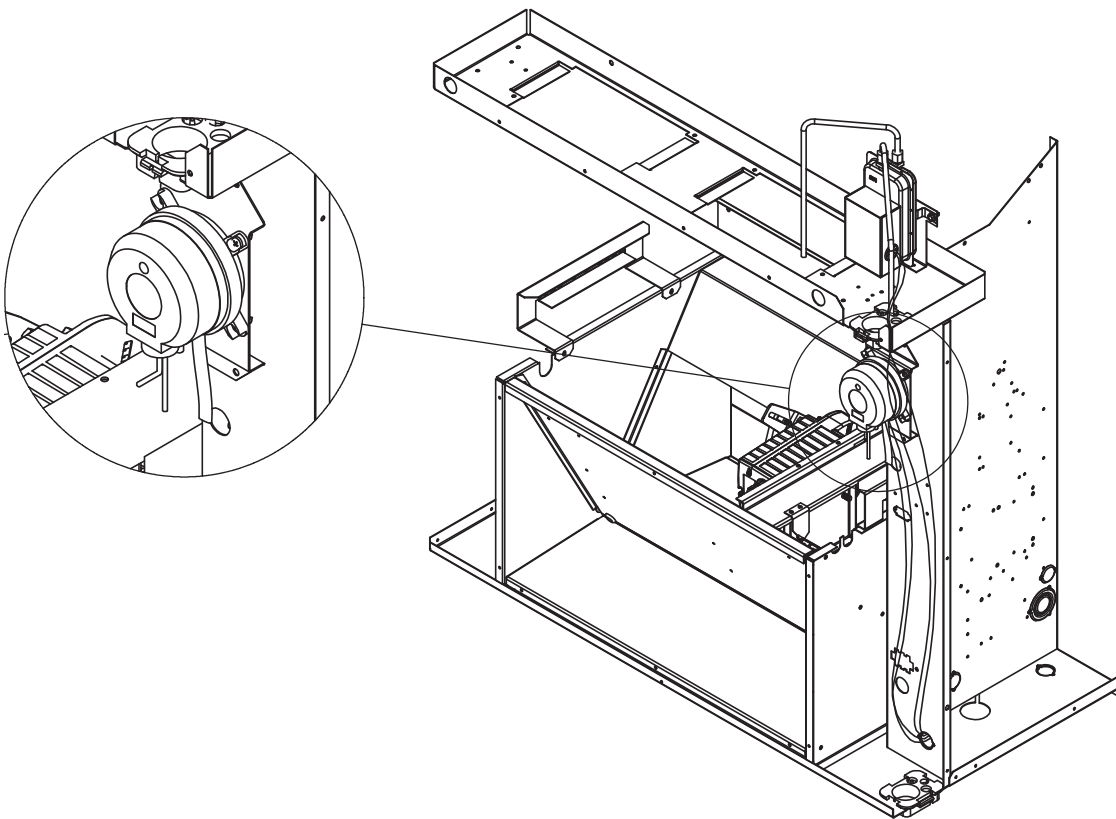

FIGURE 17
Adjusting Dirty Filter Switch

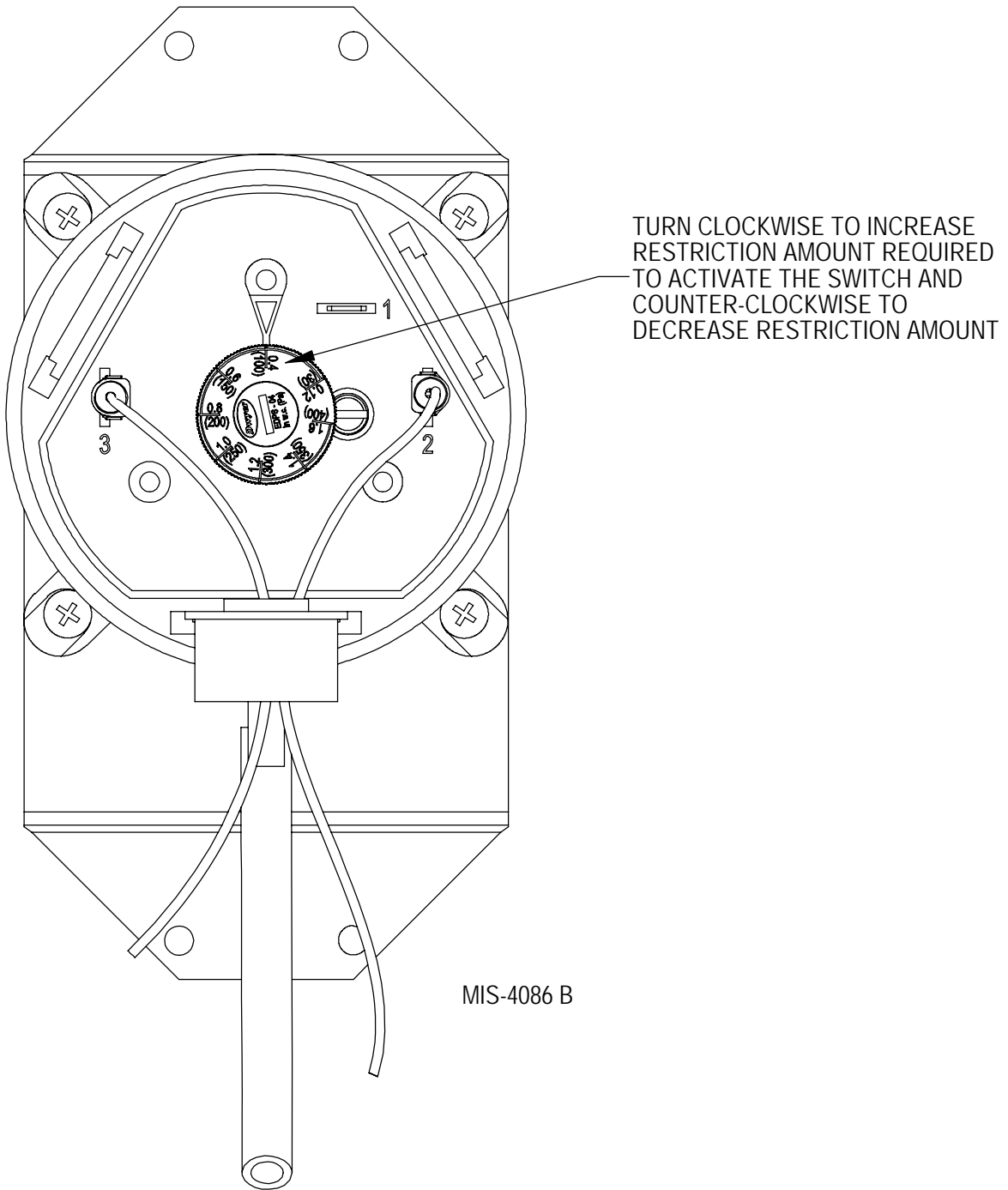

TABLE 16
Indoor Blower Performance

	E.S.P. ¹ (In. H ₂ O)	Balanced Climate™ Speed		Default LO Cooling & Heating/ Ventilation Speed ²		Optional MED Cooling & Heating Speed		Optional HI Cooling & Heating Speed	
		Dry Coil	Wet Coil	Dry Coil	Wet Coil	Dry Coil	Wet Coil	Dry Coil	Wet Coil
W18HY	0.00	600	583	665	648	756	746	799	794
	0.10	500	486	600	584	722	709	775	764
	0.15	453	439	568	553	704	690	760	747
	0.20			537	523	684	670	745	730
	0.25			507	493	664	650	727	712
	0.30			477	464	643	629	708	693
	0.40			420	407	598	586	665	652
	0.50			365	352	549	542	616	608
W24HY	0.00	653	636	840	834	960	953	1115	1110
	0.10	583	567	818	809	934	930	1075	1070
	0.15	549	534	806	794	926	915	1058	1044
	0.20	516	501	793	778	915	898	1040	1014
	0.25			777	761	899	878	1017	981
	0.30			758	742	880	856	988	944
	0.40			716	701	831	806	912	860
	0.50			664	655	767	747	814	761
W30HY	0.00			856	823	1083	1063	Dedicated electric heat speed (same as W36HY default speed)	
	0.10	778	751	1053	1036	1361	1335		
	0.15	740	713	1036	1019	1348	1318		
	0.20	702	674	1016	999	1331	1297		
	0.25			995	977	1310	1271		
	0.30			972	953	1284	1242		
	0.40			921	896	1218	1169		
	0.50			863	830	1135	1080		
W36HY	0.00			929	903	1175	1156	1372	1355
	0.10	870	848	1157	1138	1361	1335	1456	1429
	0.15	839	819	1143	1124	1348	1318	1438	1404
	0.20	808	788	1128	1107	1331	1297	1415	1374
	0.25			1109	1088	1310	1271	1386	1339
	0.30			1088	1065	1284	1242	1352	1299
	0.40			1039	1010	1218	1169	1267	1203
	0.50			978	944	1135	1080	1160	1088

¹ E.S.P. is the total combined external static pressure of both the supply and return ducts or grills.

² This is the speed set at the factory.

TABLE 17
Maximum ESP of Operation
Electric Heat Only

Model	W18H	W24H	W30H	W36H
-A04 -A05 -A08 -A10 -A15	.50	.50	.50	.50
-B05 -B09		.50	.50	.50
-C05 -C09		.50	.50	.50

Values shown are for units equipped with 2" pleated MERV 13 filter.

TABLE 18
Electric Heat

Electric Heat Nomenclature	Nominal KW	Total KW and BTUH @ Field-Supplied Voltage										
		@ 230V (1)				@ 208V (1)				@ 460V		
		KW	1 PH Amps	3 PH Amps	BTUH	KW	1 PH Amps	3 PH Amps	BTUH	KW	3 PH Amps	BTUH
4	4	3.7	16		12,600	3	14.4		10,200			
5	5	4.6	20	11.5	15,700	3.8	18	10.4	12,800	4.6	5.8	15,700
6	6	5.5		13.9	18,800	4.5		12.5	15,400	5.5	6.9	18,800
8	8	7.4	32		25,100	6	28.8		20,500			
9	9	8.3		20.8	28,300	6.8		18.7	23,000	8.3	10.4	28,300
10	10	9.2	40		31,400	7.5	36.1		25,600			
12	12									11	13.9	37,700
15	15	13.8	60	34.6	47,100	11.3	54.1	31.2	38,400	13.8	17.3	47,100
18	18	16.6		41.6	56,500	13.5		37.5	46,100	16.6	20.8	56,500
20	20	18.4	80		62,800	15	72.1		51,200			

TABLE 19
Optional Accessories

	Part Number	W18HY-A	W24HY-A	W24HY-B	W24HY-C	W30HY-A	W30HY-B	W30HY-C	W36HY-A	W36HY-B	W36HY-C
Heater Kits	EHWH018A-A04	X									
	EHWH018A-A08	X									
	EHWH024A-A04		X								
	EHWH024A-A08		X								
	EHWH024A-B05			X							
	EHWH024A-C05				X						
	EHWH030A-A05					X					
	EHWH030A-A10					X					
	EHWH030A-B05						X			X	
	EHWH030A-B09						X				
	EHWH030A-C05							X			X
	EHWH030A-C09							X			X
	EHWH036A-A05								X		
	EHWH036A-A10								X		
	EHWH036A-A15								X		
	EHWH036A-B09									X	
Circuit Breaker (WMCB) & Pull Disconnect (WMPD)	WMCB-02A	X									
	WMCB-03A		X								
	WMCB-04A					X					
	WMCB-05A								X		
	WMCB-02B			X			X				
	WMCB-03B									X	
	WMPD-01C				X			X			X

TABLE 20
Vent and Control Options

Part Number	Description	W18	W24	W30, W36
CMC-15	Start Relay (PTCR based) ①	X	X	X
CMC-31	Dirty Filter Sensor Kit	X	X	X
CMC-34	Alarm Relay	X	X	X
CMC-36	Crankcase Heater – 230V	X	X	X
CMC-37	Crankcase Heater – 460V	X	X	X
CMH-28	Outdoor Thermostat – Heat Pump (ODT)	X	X	X
CMH-33	Low Ambient Control Modulating – Heat Pump (LAC)	X		
CMH-34	Low Ambient Control – Heat Pump (LAC)		X	X
CMH-37	Low Ambient Control Modulating and Outdoor Thermostat – Heat Pump (LAC & ODT)	X		
CMH-38	Low Ambient Control and Outdoor Thermostat – Heat Pump (LAC & ODT)		X	X
SK-111	Start Kit (Hard Start) ②	X	X	X
BOP2	Blank Off Plate	X	X	
FAD-NE2	Fresh Air Damper – No Exhaust	X	X	
FAD-BE2	Fresh Air Damper – Barometric Exhaust	X	X	
CRV-F2-*	Commercial Ventilator – On/Off, Spring Return	X	X	
CRV-V2-*	Commercial Ventilator – 0-10V, Spring Return	X	X	
ECON-NC2-*	Economizer – Bldg. Equipment, 0-10V, No Controls	X	X	
ECON-S2-*	Economizer – School	X	X	
ECON-WD2-*	Economizer – Bldg. Equipment, Enthalpy	X	X	
ECON-DB2-*	Economizer – Bldg. Equipment, Temperature	X	X	
ERV-FA2-*	Energy Recovery Ventilator (230V)	X	X	
ERV-FC2-*	Energy Recovery Ventilator (460V)	X	X	
BOP3	Blank-Off Plate			X
FAD-NE3	Fresh Air Damper – No Exhaust			X
FAD-BE3	Fresh Air Damper – Barometric Exhaust			X
CRV-F3-*	Commercial Ventilator – On/Off, Spring Return			X
CRV-V3-*	Commercial Ventilator – 0-10V, Spring Return			X
ECON-NC3-*	Economizer – Bldg. Equipment, 0-10V, No Controls			X
ECON-S3-*	Economizer – School			X
ECON-WD3-*	Economizer – Bldg. Equipment, Enthalpy			X
ECON-DB3-*	Economizer – Bldg. Equipment, Temperature			X
ERV-FA3-*	Energy Recovery Ventilator (230V)			X
ERV-FC3-*	Energy Recovery Ventilator (460V)			X

① PTCR Start Kit can be used with all -A single phase models. Increases starting torque 2-3x. Not used for -B or -C three phase models. Do not use if SK111 is used.

② Start capacitor and potential relay start kit can be used with all -A single phase models. Increases starting torque 9x. Not used for -B or -C three phase models. Do not use if CMC-15 is used.

* Insert color to match unit (X = Beige, 1 = White, 4 = Gray, 5 = Desert Brown, 8 = Dark Bronze, S = Stainless, A = Aluminum)

GRAPH 1
W18HY FAD-NE2, 3 W/O Exhaust Ventilation Delivery

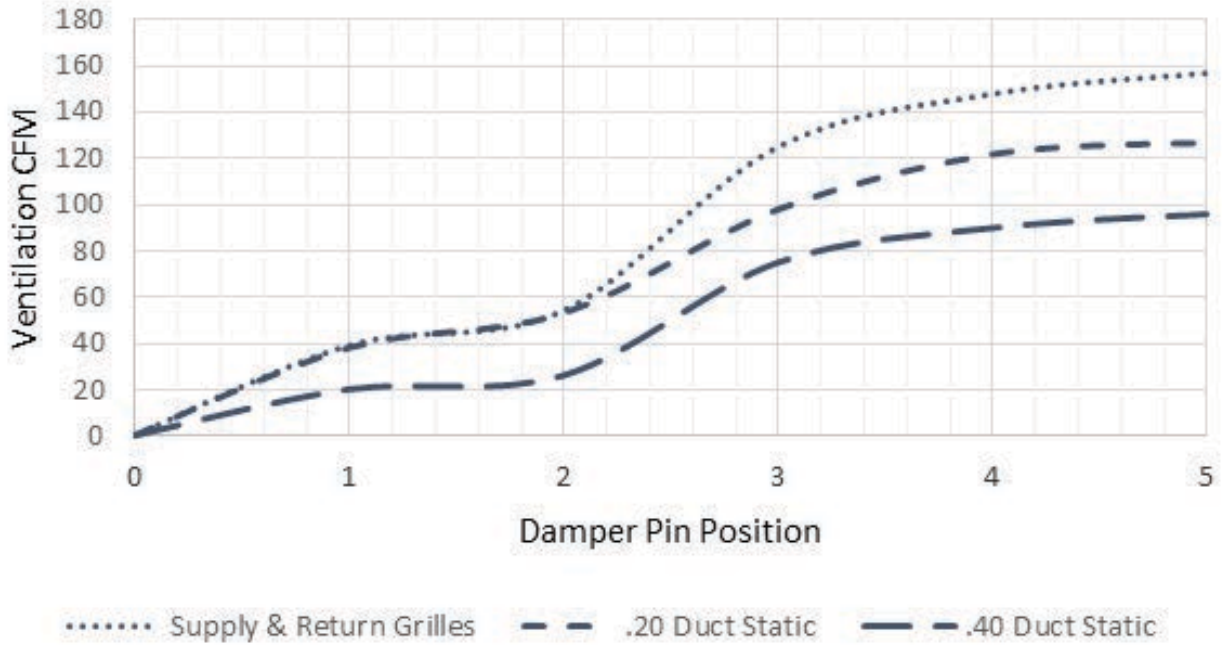

GRAPH 2
W24HY FAD-NE2, 3 W/O Exhaust Ventilation Delivery

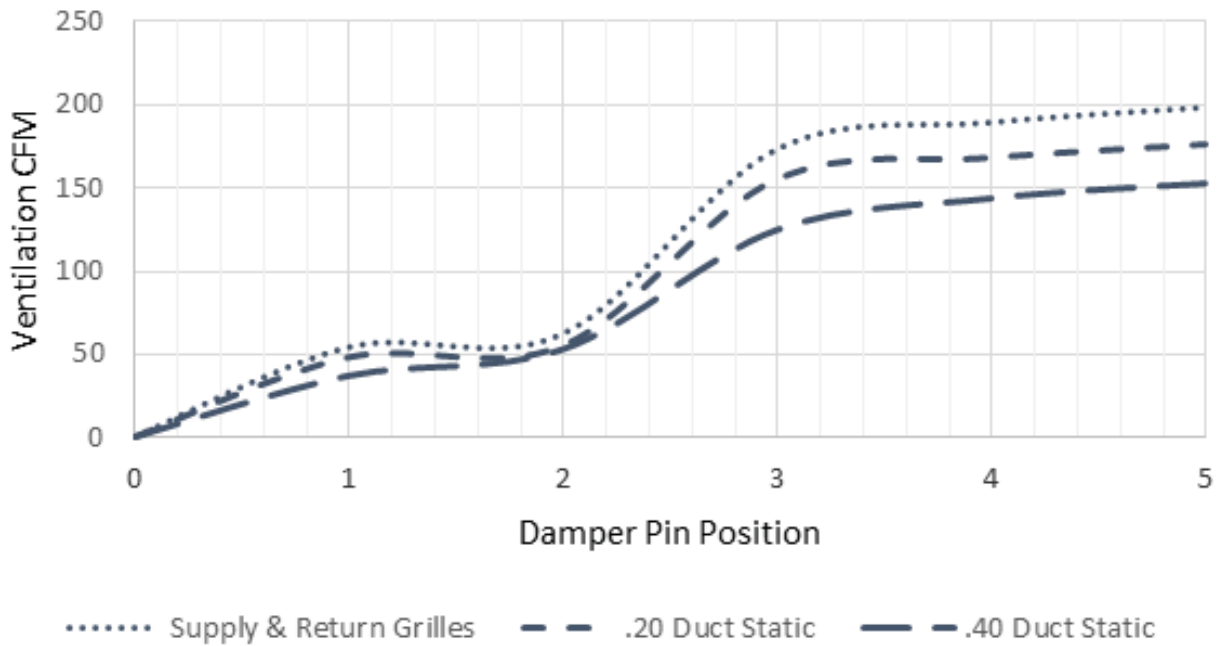

GRAPH 3
W30HY FAD-NE2, 3 W/O Exhaust Ventilation Delivery

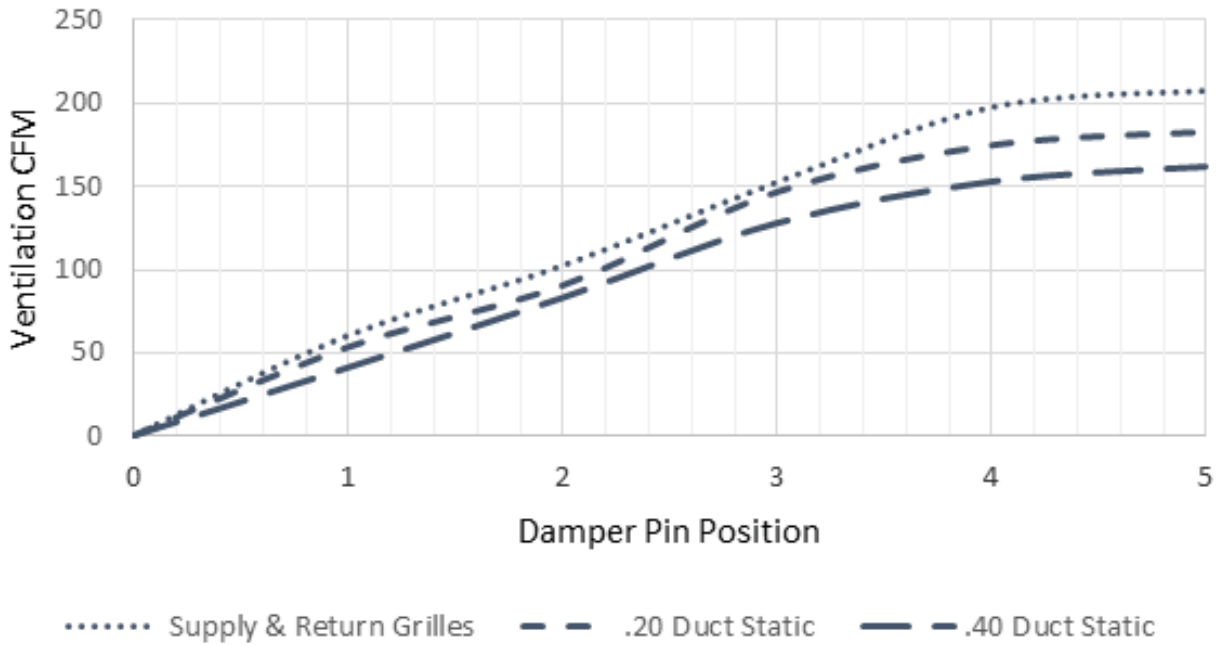

GRAPH 4
W36HY FAD-NE2, 3 W/O Exhaust Ventilation Delivery

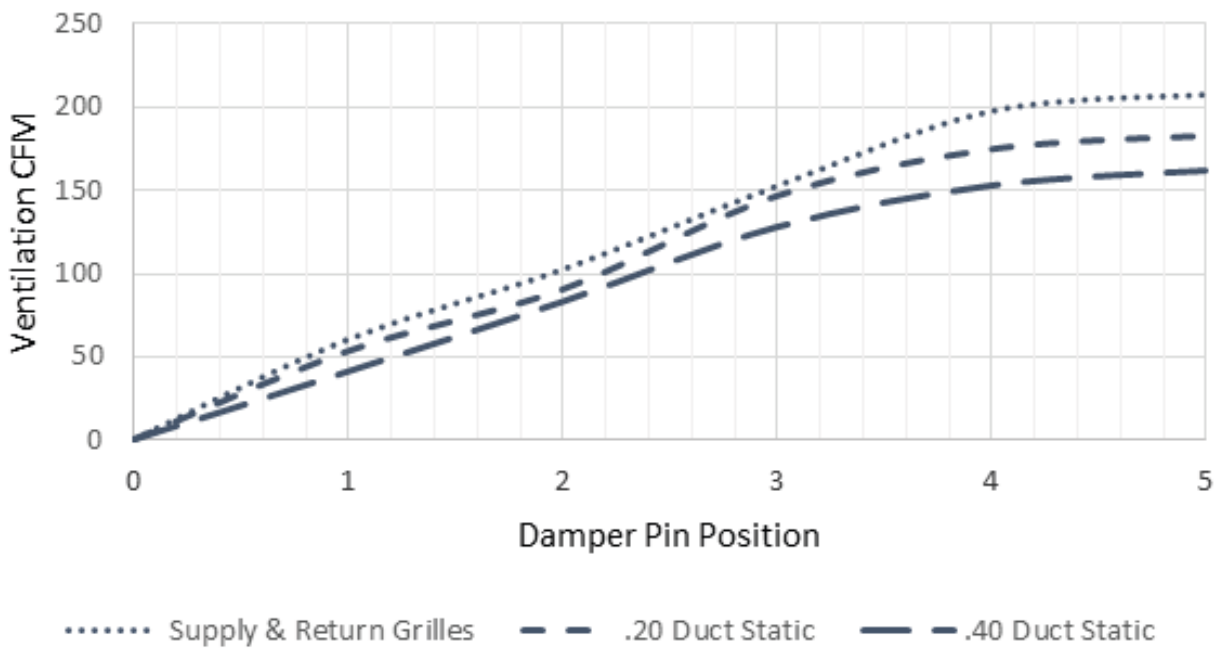

REPLACEMENT PARTS MANUAL

Wall Mounted Packaged Heat Pump

Models:

W18HY-A W24HY-A W24HYDA
 W24HY-B W24HYDB
 W24HY-C W24HYDC

Contents

Description	Page	Description	Page
Cabinet Components		Blower Assembly	
♦ Exploded View	2	♦ Exploded View	16
♦ Usage List	3	♦ Usage List	16
♦ Usage List	4	EEV Controller Assembly	
Functional Components – Standard Units		♦ Exploded View	17
♦ Exploded View	6	♦ Usage List	17
♦ Usage List	7		
Functional Components – Dehumidification Units			
♦ Exploded View	8		
♦ Usage List	9		
Control Panel – 230 Volt 1 Phase Units			
♦ Layout View	10		
♦ Usage List	11		
Control Panel – 230 Volt 3 Phase Units			
♦ Layout View	12		
♦ Usage List	13		
Control Panel – 460 Volt 3 Phase Units			
♦ Layout View	14		
♦ Usage List	15		

General Notes

- Revised and/or additional pages may be issued from time to time.
- A complete and current manual consists of pages shown in the contents section.

Important

- Contact the installing and/or local Bard distributor for all parts requirements. Make sure to have the complete model and serial number available from the unit rating plates.



Bard Manufacturing Company, Inc.
Bryan, Ohio 43506
www.bardhvac.com

Manual: 2110-1579A
Supersedes: 2110-1579
Date: 1-3-24

CABINET COMPONENTS

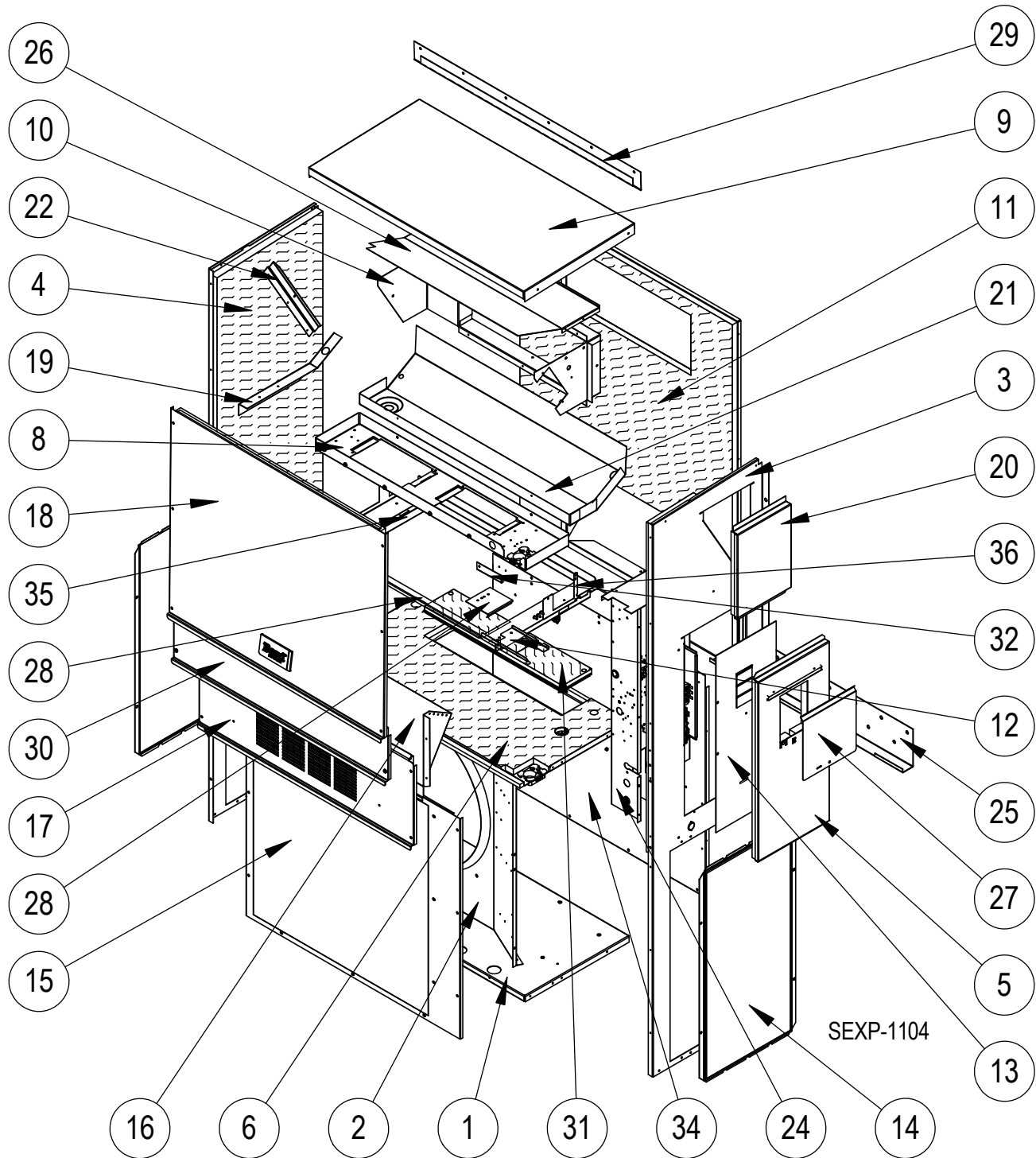

This drawing to be used for reference for pages 3 and 4

CABINET COMPONENTS

Dwg No.	Part Number	Description	W18HY-A	W24HY-A, B	W24HY-C	W24HYDA, B	W24HYDC
1	127-467BX	Lower Base	X	X	X	X	X
1	127-534BX ②	Lower Base	X	X	X	X	X
2	125-080BX	Fan Shroud	X	X	X	X	X
2	125-082BX ②	Fan Shroud	X	X	X	X	X
3	501-933-*BX ①	Right Side	X	X	X	X	X
3	501-994-*BX ②	Right Side	X	X	X	X	X
3	501-937BX ③	Right Side	X	X	X	X	X
4	501-934-*BX ①	Left Side	X	X	X	X	X
4	501-995-*BX ②	Left Side	X	X	X	X	X
4	501-940BX ③	Left Side	X	X	X	X	X
5	533-228-*BX ①	Control Panel Cover (Outer)	X	X	X	X	X
5	533-235BX ②	Control Panel Cover (Outer)	X	X	X	X	X
5	533-236BX ③	Control Panel Cover (Outer)	X	X	X	X	X
6	521X528BX	Condenser Partition	X	X	X	X	X
6	521-553BX ②	Condenser Partition	X	X	X	X	X
8	121X480BX	Blower Partition	X	X	X	X	X
9	507-311-*BX ①	Top	X	X	X	X	X
9	507-318-*BX ③	Top	X	X	X	X	X
9	507-317BX ②	Top	X	X	X	X	X
10	111X032BX	Outlet Air Frame Assembly	X	X	X	X	X
11	509-445BX	Upper Back	X	X	X	X	X
11	509-447BX ③	Upper Back	X	X	X	X	X
11	509-449BX ②	Upper Back	X	X	X	X	X
12	137X1011BX	Filter Fill Plate	X	X	X	X	X
13	132-104BX	Control Panel Cover (Inner)	X	X		X	
13	132-172BX	Control Panel Cover (Inner)			X		X
14	118-124-*BX ①	Side Grille	2	2	2	2	2
14	118-140BX ②	Side Grille	2	2	2	2	2
14	118-141BX ③	Side Grille	2	2	2	2	2
15	118-101-*BX ①	Condenser Grille	X	X	X	X	X
15	118-106BX ②	Condenser Grille	X	X	X	X	X
15	118-144BX ③	Condenser Grille	X	X	X	X	X
16	BFAD-2	Fresh Air Damper Assembly	X	X	X	X	X
17	553-537-*BX ①	Vent Option Door	X	X	X	X	X
17	553-547BX ②	Vent Option Door	X	X	X	X	X
17	553-548BX ③	Vent Option Door	X	X	X	X	X
17	553-539-*BX ①	Vent Option Door with ERV	X	X	X	X	X
17	553-555BX ②	Vent Option Door with ERV	X	X	X	X	X
17	553-556BX ③	Vent Option Door with ERV	X	X	X	X	X
17	553-666-*BX ①	Vent Option Door with CRV or ECON-S	X	X	X	X	X
17	553-692BX ②	Vent Option Door with CRV or ECON-S	X	X	X	X	X
17	553-693BX ③	Vent Option Door with CRV or ECON-S	X	X	X	X	X
18	514-240-*BX ①	Upper Front	X	X	X	X	X
18	514-237-*BX ③	Upper Front	X	X	X	X	X
18	514-236BX ②	Upper Front	X	X	X	X	X

Continued on page 4

- ① Exterior cabinet parts are manufactured with various paint color options. To ensure the proper paint color is received, include the complete model and serial number of the unit for which cabinet parts are being ordered.
- ② Exterior cabinet parts are manufactured from stainless steel Code "S"
- ③ Exterior cabinet parts are manufactured from aluminum Code "A"

CABINET COMPONENTS

Dwg. No.	Part Number	Description	W18HY-A	W24HY-A, B	W24HY-C	W24HYDA, B	W24HYDC
<i>Continued from page 3</i>							
19	105X850BX	Side Support	X	X	X	X	X
20	543-175-*BX ①	Right Side Cover Plate (Outer)	X	X	X	X	X
20	543-185BX ②	Right Side Cover Plate (Outer)	X	X	X	X	X
20	543-184BX ③	Right Side Cover Plate (Outer)	X	X	X	X	X
21	123-126BX	Drain Pan	X	X	X	X	X
21	123-140BX ②③	Drain Pan	X	X	X	X	X
22	147-044BX	Evaporator Support	X	X	X	X	X
24	Control Panel Assembly	See Control Panel on pages 10 – 15	X	X	X	X	X
25	113-140BX	Bottom Mounting Bracket	X	X	X	X	X
26	135X127BX	Heat Shield	X	X	X	X	X
27	153-218BX ①	Disconnect Access Door	X	X	X	X	X
27	153-405BX ②	Disconnect Access Door	X	X	X	X	X
27	153-387BX ③	Disconnect Access Door	X	X	X	X	X
28	131-196BX	Filter Partition Bracket	X	X	X	X	X
29	113-141-*BX ①	Top Rain Flashing	X	X	X	X	X
29	113-361BX ②	Top Rain Flashing	X	X	X	X	X
29	113-141-4BX ③	Top Rain Flashing	X	X	X	X	X
30	553-538-*BX ①	Filter Door	X	X	X	X	X
30	553-552-*BX ③	Filter Door	X	X	X	X	X
30	553-551BX ②	Filter Door	X	X	X	X	X
31	536-176BX	Cond. Partition Block Off Plate	X	X	X	X	X
31	536-878BX ②	Cond. Partition Block Off Plate	X	X	X	X	X
32	105-1302BX	Grommet Retainer	X	X	X	X	X
34	109-444BX	Lower Back	X	X	X	X	X
34	109-446BX ③	Lower Back	X	X	X	X	X
34	109-448BX ②	Lower Back	X	X	X	X	X
35	131-192BX	Filter Tray Angle	X	X	X	X	X
36	131X191BX	Filter Partition	X	X	X	X	X
NS	5252-033	Bard Nameplate	X	X	X	X	X

① Exterior cabinet parts are manufactured with various paint color options. To ensure the proper paint color is received, include the complete model and serial number of the unit for which cabinet parts are being ordered.

② Exterior cabinet parts are manufactured from stainless steel Code "S"

③ Exterior cabinet parts are manufactured from aluminum Code "A"

Refer to drawing on page 2

This page intentionally left blank

FUNCTIONAL COMPONENTS – STANDARD UNITS

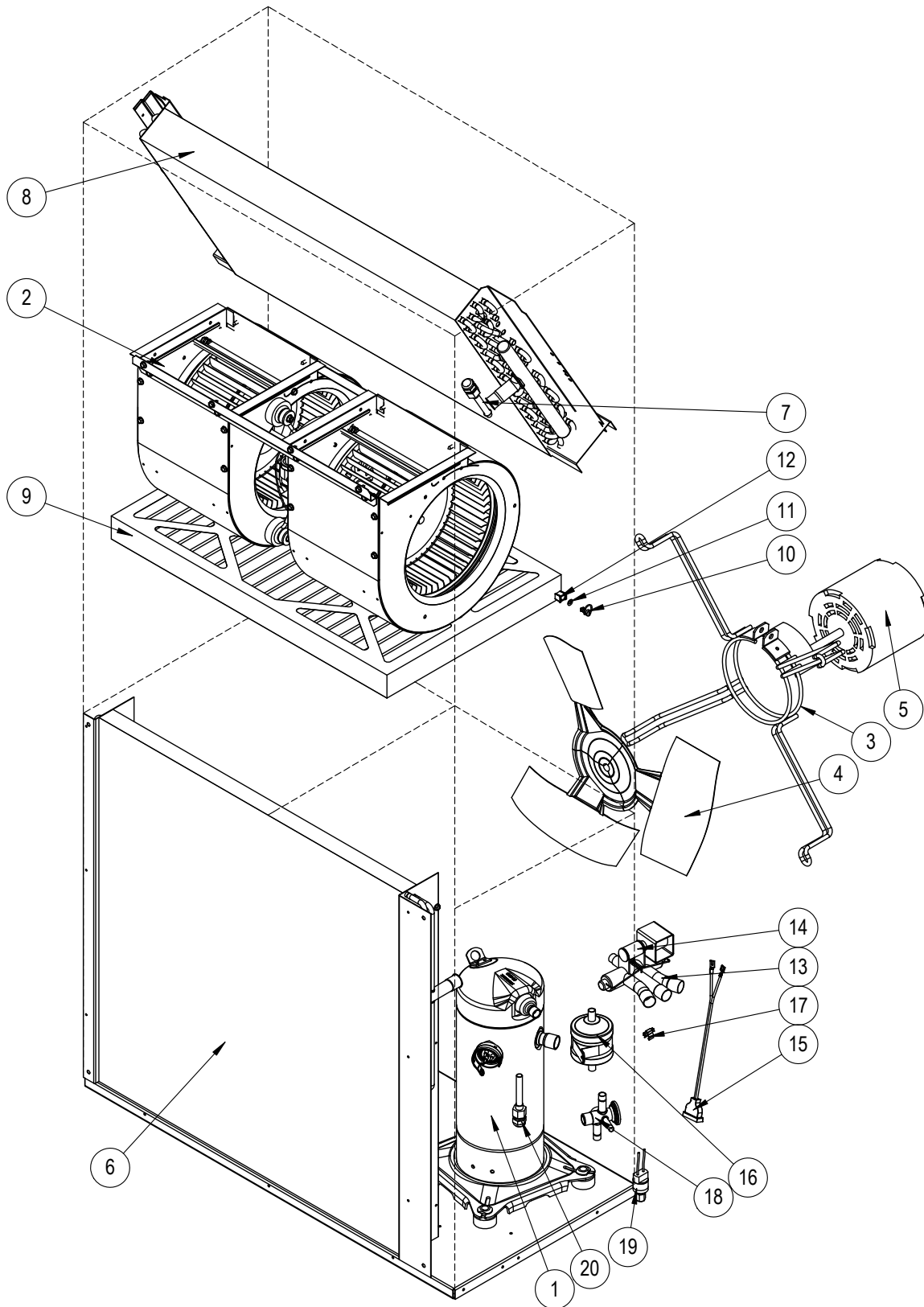

SEXP-985

FUNCTIONAL COMPONENTS – STANDARD UNITS

Dwg No.	Part Number	Description	W18HY-A	W24HY-A	W24HY-B	W24HY-C
1	8000-433BX	Compressor	X			
1	8000-441BX	Compressor		X		
1	8000-435BX	Compressor			X	
1	8000-436BX	Compressor				X
NS	3000-1224BX	Molded Compressor Wire Harness (1-PH)	X	X		
NS	3000-1231BX	Molded Compressor Wire Harness (3-PH)			X	X
2	900-358-0168BX	Blower Assembly	X			
2	900-358-0169BX	Blower Assembly		X	X	
2	900-359-0170BX	Blower Assembly				X
3	8200-001BX	Fan Motor Mount	X	X	X	X
3	8200-050BX ①	Stainless Steel Fan Motor Mount	X	X	X	X
4	5151-033BX	Fan Blade	X	X	X	
4	5151C033BX ①	Coated Fan Blade	X	X	X	
4	5151-046BX	Fan Blade				X
4	5151C046BX ①	Coated Fan Blade				X
5	8103-028BX	Outdoor Fan Motor	X	X	X	
5	8103-030BX	Outdoor Fan Motor				X
6	917-0385BX	Outdoor Coil (Includes Distributor)	X			
6	917-0390BX ②	Outdoor Coil – Coated (Includes Distributor)	O			
6	917-0386BX	Outdoor Coil (Includes Distributor)		X	X	X
6	917-0391BX ②	Outdoor Coil – Coated (Includes Distributor)		O	O	O
7	800-0427BX	Cooling Distributor Assembly	X			
7	800-0485BX	Cooling Distributor Assembly		X	X	X
8	917-0388BX	Indoor Coil (Includes Cooling Distributor)	X			
8	917-0393BX ②	Indoor Coil – Coated (Includes Cooling Distributor)	O			
8	917-0399BX	Indoor Coil (Includes Cooling Distributor)		X	X	X
8	917-0400BX ②	Indoor Coil – Coated (Includes Cooling Distributor)		O	O	O
9	7004-011	Air Filter 16" x 25" x 1" Disposable	X	X	X	X
9	7003-032 ②	Air Filter 16" x 25" x 1" Washable	O	O	O	O
9	7004-025 ②	Air Filter 16" x 25" x 2" Pleated Disposable	O	O	O	O
10	1171-022	1/4 Turn Fastener	X	X	X	X
11	1171-024	1/4 Turn Retainer	X	X	X	X
12	1171-023	1/4 Turn Receptacle	X	X	X	X
13	5650-038BX	Reversing Valve w/24V Solenoid Coil	X	X	X	X
14	5650-046BX	Reversing Valve 24V Solenoid	X	X	X	X
15	5650-044BX	Molded Plug 53" Lead	X	X	X	X
16	5201-019BX	Filter Drier, Bi-Directional, 3/8" Connections	X	X	X	X
17	8620-224	Defrost Sensor Kit	X	X	X	X
18	5651-218BX	Heating Expansion Valve	X	X	X	X
19	8406-142BX	High Pressure Switch (650#) Screw On	X	X	X	X
20	5625-127BX	Heating Distributor	X	X	X	X
NS	8406-135BX	Low Pressure Switch (14#) Screw On	X	X	X	X
NS	6031-009	Coremax Valve Core (Service Port)	2	2	2	2
NS	8612-027BX ②	Low Ambient Fan Control (Modulating)	O			
NS	8406-105BX ②	Low Ambient Fan Cycling Control (280#/180#)		O	O	O
NS	8408-028BX ②	Outdoor Thermostat	O	O	O	O
NS	1171-028	Filter Door Clip	X	X	X	X
NS	1171-057	Filter Door Screw	X	X	X	X
NS	1171-027	Filter Door Screw Retainer	X	X	X	X
NS	CMC-29 ②	Freeze Thermostat Kit	O	O	O	O

NS – Not Shown

① – Used with stainless steel cabinet option

② – Optional on these models

X – Standard

O – Add-On Option

FUNCTIONAL COMPONENTS – DEHUMIDIFICATION UNITS

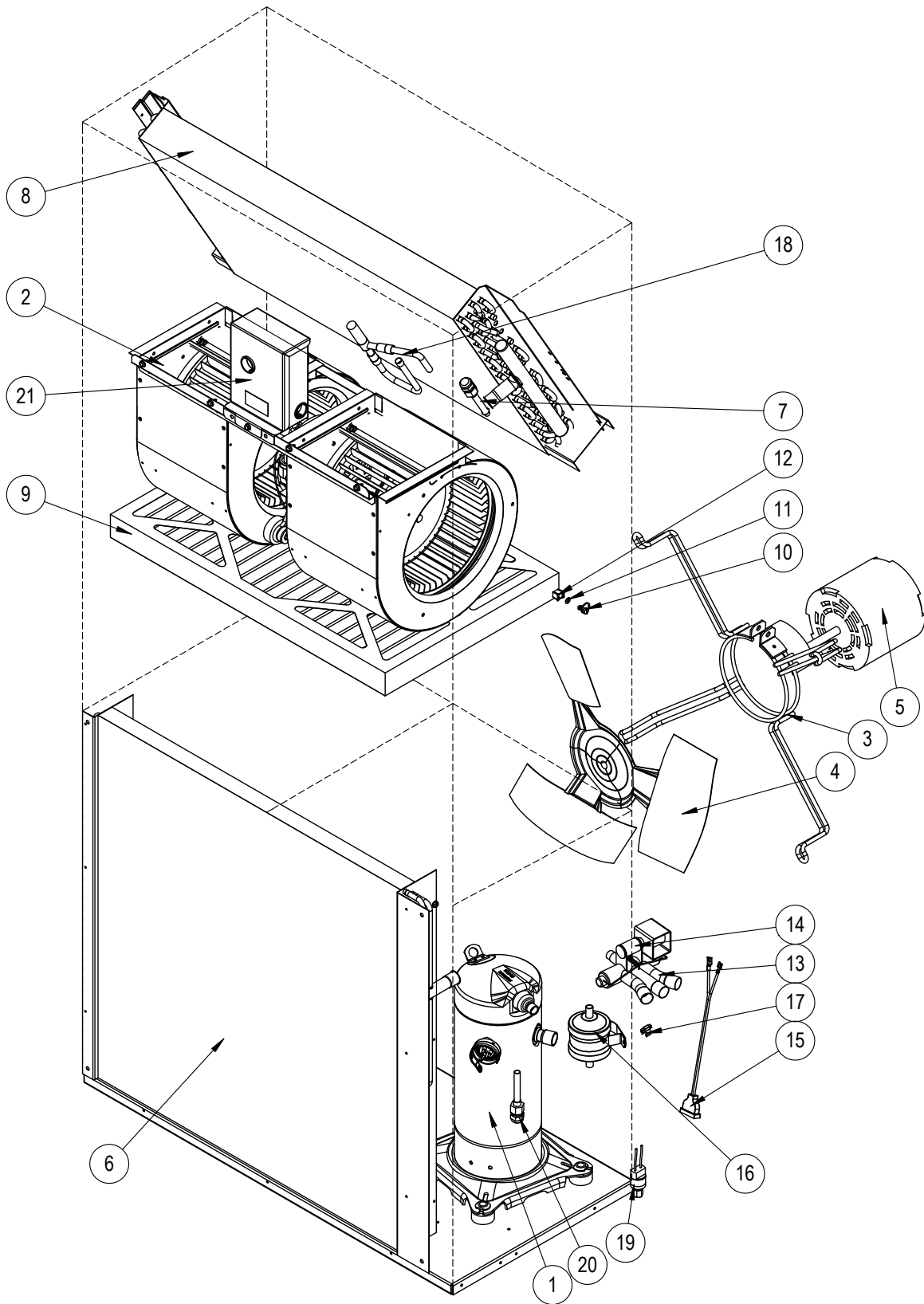

SEXP-986

FUNCTIONAL COMPONENTS – DEHUMIDIFICATION UNITS

Dwg No.	Part Number	Description	W24HYDA	W24HYDB	W24HYDC
1	8000-441BX	Compressor	X		
1	8000-435BX	Compressor		X	
1	8000-436BX	Compressor			X
NS	3000-1224BX	Molded Compressor Wire Harness (1-PH)	X		
NS	3000-1231BX	Molded Compressor Wire Harness (3-PH)		X	X
2	900-358-0169BX	Blower Assembly	X	X	
2	900-359-0170BX	Blower Assembly			X
3	8200-001BX	Fan Motor Mount	X	X	X
3	8200-050BX ①	Stainless Steel Fan Motor Mount	X	X	X
4	5151-033BX	Fan Blade	X	X	
4	5151C033BX ①	Coated Fan Blade	X	X	
4	5151-046BX	Fan Blade			X
4	5151C046BX ①	Coated Fan Blade			X
5	8103-028BX	Outdoor Fan Motor	X	X	
5	8103-030BX	Outdoor Fan Motor			X
6	917-0386BX	Outdoor Coil (Includes Distributor)	X	X	X
6	917-0391BX ②	Outdoor Coil – Coated (Includes Distributor)	O	O	O
7	800-0426BX	Cooling Distributor Assembly	X	X	X
8	917-0383BX	Indoor Coil (Includes Cooling Distributor)	X	X	X
8	917-0395BX ②	Indoor Coil – Coated (Includes Cooling Distributor)	O	O	O
9	7004-011	Air Filter 16" x 25" x 1" Disposable	X	X	X
9	7003-032 ②	Air Filter 16" x 25" x 1" Washable	O	O	O
9	7004-025 ②	Air Filter 16" x 25" x 2" Pleated Disposable	O	O	O
10	1171-022	1/4 Turn Fastener	X	X	X
11	1171-024	1/4 Turn Retainer	X	X	X
12	1171-023	1/4 Turn Receptacle	X	X	X
13	5650-038BX	Reversing Valve w/24V Solenoid Coil	X	X	X
14	5650-046BX	Reversing Valve 24V Solenoid	X	X	X
15	5650-044BX	Molded Plug 53" Lead	X	X	X
16	5201-019BX	Filter Drier, Bi-Directional, 3/8" Connections	X	X	X
17	8620-224	Defrost Sensor Kit	X	X	X
18	5651-245BX	Electronic Expansion Valve	X	X	X
19	8406-142BX	High Pressure Switch (650#) Screw On	X	X	X
20	5625-014BX	Heating Distributor	X	X	X
21	EEV Controller Assy.	See EEV CONTROLLER ASSEMBLY on page 17	X	X	X
NS	8406-135BX	Low Pressure Switch (14#) Screw On	X	X	X
NS	8406-158BX	Low Pressure Transducer	X	X	X
NS	6031-009	Coremax Valve Core (Service Port)	2	2	2
NS	5650-051BX	Dehumidification Mode Valve	X	X	X
NS	5651-219BX	Dehumidification Check Valves	2	2	2
NS	8406-105BX ②	Low Ambient Fan Cycling Control (280#/180#)	O	O	O
NS	8408-028BX ②	Outdoor Thermostat	O	O	O
NS	1171-028	Filter Door Clip	X	X	X
NS	1171-057	Filter Door Screw	X	X	X
NS	1171-027	Filter Door Screw Retainer	X	X	X

NS – Not Shown

① – Used with stainless steel cabinet option

② – Optional on these models

X – Standard

O – Add-On Option

CONTROL PANEL – 230 VOLT 1 PHASE UNITS

Dwg No.	Part Number	Description	W18HY-A	W24HY-A	W24HYDA
1	117X137BX	Control Panel Top - RH (Sheet Metal Only)	X	X	X
2	117X374BX	Control Panel - RH (Sheet Metal Only)	X	X	X
3	117X375BX	Low Voltage Box - RH (Sheet Metal Only)	X	X	X
4	117X385BX	Low Voltage Partition - RH (Sheet Metal Only)	X	X	X
NS	3000-1494BX	Low Voltage Wire Harness (behind LVTS)	X	X	X
NS	910-2047BX	Complete Low Voltage Box Assembly (Sheet Metal, LVTS & Wire Harness)	X	X	X
5	141-596BX	Plug Support Bracket (Sheet Metal)	X	X	X
6	135-122BX	Wire Shield (Sheet Metal)	X	X	X
7	8401-033BX	Contactora 2-Pole	X	X	X
8	8407-068BX	Transformer 208/240-24, 50VA	X	X	X
9	8201-130BX	Relay, SPDT	X	X	X
10	8620-223	Defrost Board Replacement Kit w/Sensor	X	X	X
11	8607-044BX	Terminal Strip	X	X	X
12	8607-042BX	Blower Speed Terminal	X	X	X
13	8611-006	Ground Lug	X	X	X
25	8611-140-1400	14" Cable Duct	X	X	X
26	8611-140-0500	5" Cable Duct	X	X	X
27	8552-047BX	Capacitor 30+5/370 V, 2-1/2" Round	X		
27	8552-050BX	Capacitor 40+5/370 V, 2-1/2" Round		X	X
28	8550-008	Capacitor Strap, 2-1/2" Round	X	X	X
31	8201-113BX	Dehumidification Logic Control Board			X
NS	3003-132BX	Main Control Panel Wire Harness	X	X	
NS	3003-135BX	Main Control Panel Wire Harness			X
NS	8201-086BX ①	LAC and/or ODT Relay	O	O	O
NS	8408-028BX ①	Outdoor Thermostat	O	O	O
NS	3000-1598BX	Blower Power Plug	X	X	X
NS	3000-1599BX	Blower Speed Plug	X	X	X
NS	4096-189	Wiring Diagram	X	X	
NS	4096-190	Wiring Diagram			X

NS – Not Shown

① – Optional

X – Standard

O – Add-On Option

CONTROL PANEL – 230 VOLT 3 PHASE UNITS

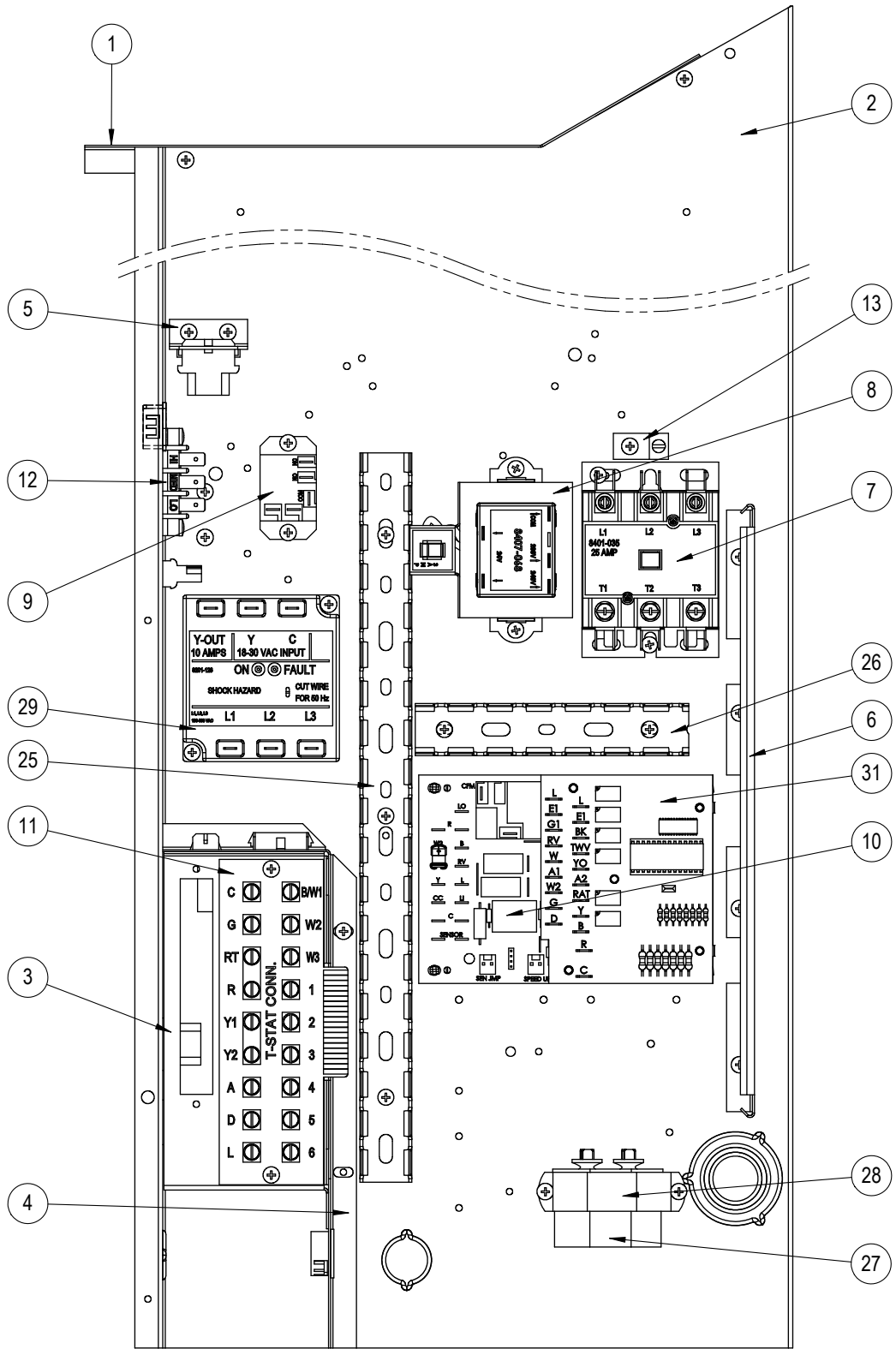

SEXP-988

CONTROL PANEL – 230 VOLT 3 PHASE UNITS

Dwg No.	Part Number	Description	W24HY-B	W24HYDB
1	117X137BX	Control Panel Top - RH (Sheet Metal Only)	X	X
2	117X374BX	Control Panel - RH (Sheet Metal Only)	X	X
3	117X375BX	Low Voltage Box - RH (Sheet Metal Only)	X	X
4	117X385BX	Low Voltage Partition - RH (Sheet Metal Only)	X	X
NS	3000-1494BX	Low Voltage Wire Harness (behind LVTS)	X	X
NS	910-2047BX	Complete Low Voltage Box Assembly (Sheet Metal, LVTS & Wire Harness)	X	X
5	141-596BX	Plug Support Bracket (Sheet Metal)	X	X
6	135-122BX	Wire Shield (Sheet Metal)	X	X
7	8401-035BX	Contactors 3-Pole	X	X
8	8407-068BX	Transformer 208/240-24, 50VA	X	X
9	8201-130BX	Relay, SPDT	X	X
10	8620-223	Defrost Board Replacement Kit w/Sensor	X	X
11	8607-044BX	Terminal Strip	X	X
12	8607-042BX	Blower Speed Terminal	X	X
13	8611-006	Ground Lug	X	X
25	8611-140-1400	14" Cable Duct	X	X
26	8611-140-0500	5" Cable Duct	X	X
27	8552-002BX	Capacitor 5/370 V, 1-1/4" Oval	X	X
28	8550-003	Capacitor Strap, 1-1/4" Oval	X	X
29	8201-174BX	3 Phase Line Monitor	X	X
31	8201-113BX	Dehumidification Logic Control Board		X
NS	3003-133BX	Main Control Panel Wire Harness	X	
NS	3003-136BX	Main Control Panel Wire Harness		X
NS	8201-086BX ①	LAC and/or ODT Accessory Relay	O	O
NS	8408-028BX ①	Outdoor Thermostat	O	O
NS	3000-1598BX	Blower Power Plug	X	X
NS	3000-1599BX	Blower Speed Plug	X	X
NS	4096-289	Wiring Diagram	X	
NS	4096-290	Wiring Diagram		X

NS – Not Shown

① – Optional

X – Standard

O – Add-On Option

CONTROL PANEL – 460 VOLT 3 PHASE UNITS

Dwg No.	Part Number	Description	W24HY-C	W24HYDC
1	117X137BX	Control Panel Top - RH (Sheet Metal Only)	X	X
2	117X374BX	Control Panel - RH (Sheet Metal Only)	X	X
3	117X375BX	Low Voltage Box - RH (Sheet Metal Only)	X	X
4	117X385BX	Low Voltage Partition - RH (Sheet Metal Only)	X	X
NS	3000-1494BX	Low Voltage Wire Harness (behind LVTS)	X	X
NS	910-2047BX	Complete Low Voltage Box Assembly (Sheet Metal, LVTS & Wire Harness)	X	X
5	141-596BX	Plug Support Bracket (Sheet Metal)	X	X
6	135-122BX	Wire Shield (Sheet Metal)	X	X
7	8401-035BX	Contactora 3-Pole	X	X
8	8407-069BX	Transformer 480-24, 50VA	X	X
9	8201-032BX	Relay, SPDT, 3 FLA@480V	X	X
10	8620-223	Defrost Board Replacement Kit w/Sensor	X	X
11	8607-044BX	Terminal Strip	X	X
12	8607-042BX	Blower Speed Terminal	X	X
13	8611-006	Ground Lug	X	X
25	8611-140-1400	14" Cable Duct	X	X
26	8611-140-0500	5" Cable Duct	X	X
27	8552-002BX	Capacitor 5/370 V, 1-1/4" Oval	X	X
28	8550-003	Capacitor Strap, 1-1/4" Oval	X	X
29	8201-174BX	3 Phase Line Monitor	X	X
31	8201-113BX	Dehumidification Logic Control Board		X
NS	3003-134	Main Control Panel Wire Harness	X	
NS	3003-137	Main Control Panel Wire Harness		X
NS	8201-086BX ①	LAC and/or ODT Accessory Relay	O	O
NS	8408-028BX ①	Outdoor Thermostat	O	O
NS	3000-1598BX	Blower Power Plug	X	X
NS	3000-1599BX	Blower Speed Plug	X	X
NS	4096-389	Wiring Diagram	X	
NS	4096-390	Wiring Diagram		X

NS – Not Shown

① – Optional

X – Standard

O – Add-On Option

BLOWER ASSEMBLY

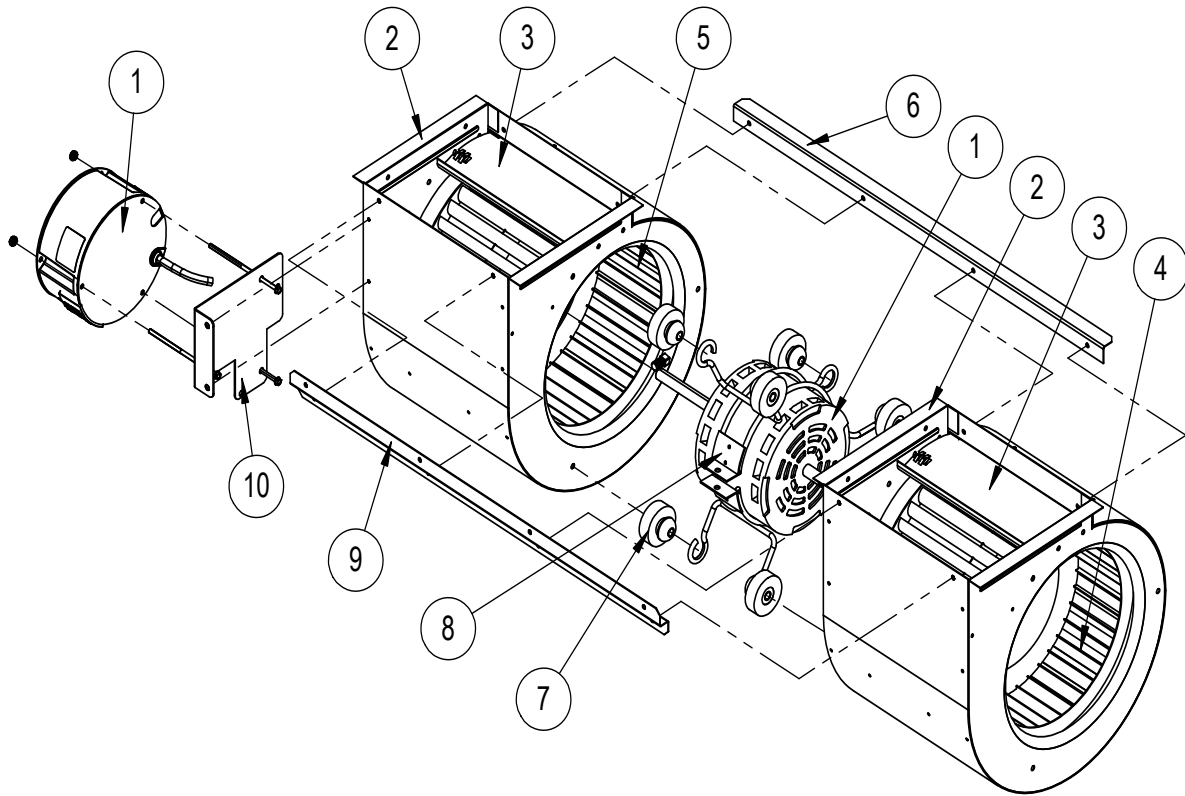

SEXP-909

Dwg No.	Part Number	Description	900-358-0168BX	900-358-0169BX	900-359-0170BX
1	8105-064-0168BX	Blower Motor & Control (230/208V)	X		
1	8105-064-0169BX	Blower Motor & Control (230/208V)		X	
1	8105-065-0170BX	Blower Motor & Control (460V)			X
1	C8105-064-0168	Programmed Control Only (230/208V)	0		
1	C8105-064-0169	Programmed Control Only (230/208V)		0	
1	C8105-065-0170	Programmed Control Only (460V)			0
2	151-115BX	Housing	2	2	2
3	144-183BX	Cutoff	X	X	X
4	5152-092BX	Wheel 9-6 CW	X	X	X
5	5152-093BX	Wheel 9-6 CCW	X	X	X
6	105-1061BX	Back Brace	X	X	X
7	5451-011	Grommets	6	6	6
8	8200-031BX	Motor Mount	X	X	X
9	103-435BX	Front Brace	X	X	X
10	113-721BX	Motor Control Bracket	X	X	X

X – Standard Component
O – Optional Component

EEV CONTROLLER ASSEMBLY

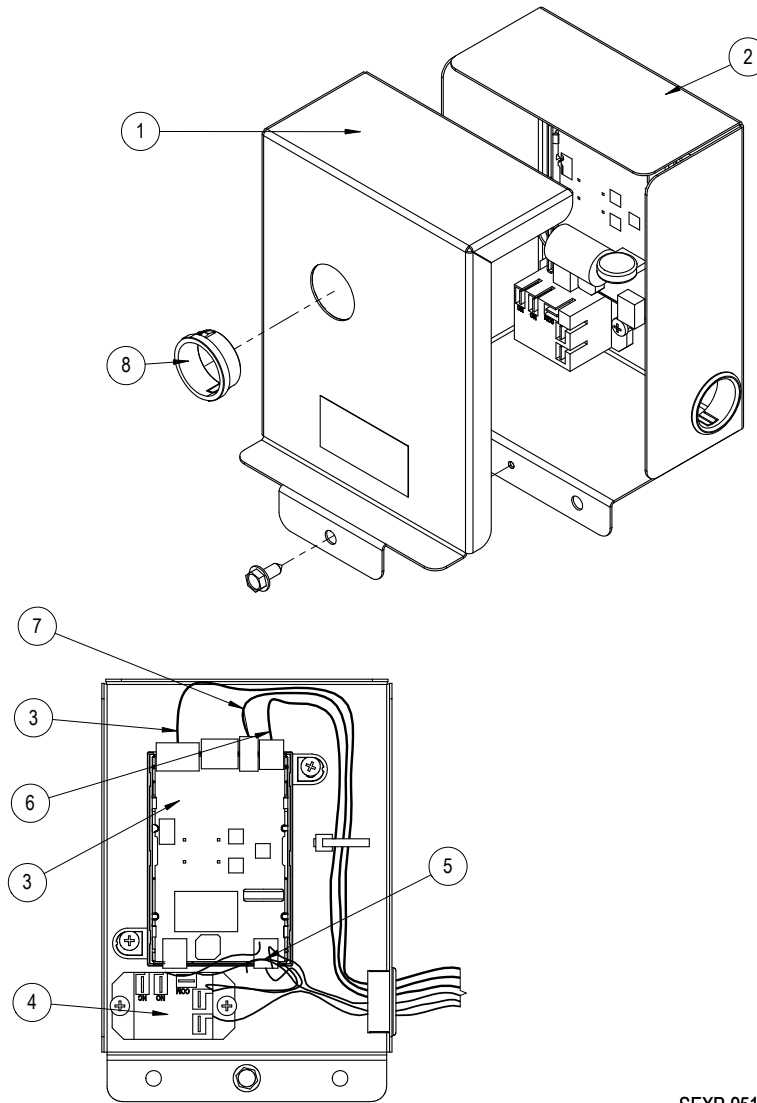

SEXP-951

910-2050-002BX

Dwg No.	Part Number	Description	
1	143-219BX	EEV Control Box Cover	X
2	127-572BX	EEV Control Box	X
3	8301-079-0002BX	EEV Control & Stator Cable	X
3	5651-246BX	EEV Stator Cable Only	X
4	8201-130BX	Control Relay	X
5	3000-1602BX	Main Wire Assembly	X
6	3000-1611BX	Transducer Wire Assembly – EEV Board to QC	X
7	8408-056BX	EEV Thermistor	X
8	8611-075	Clear Snap Plug	X



Climate Control Solutions

Limited Warranty

**For units applied within the United States, Puerto Rico,
US Virgin Islands, Guam, Canada and Mexico**

Limited Warranty To Original Purchaser:

Bard Manufacturing Company, Inc. Bryan, Ohio 43506 warrants to you, the original purchaser, that your Bard product will be free from defects in materials and workmanship when used under normal conditions from the installation date through the time periods outlined in the "Duration of Warranty" section (see reverse side).

Proof Of Purchase:

You must be able to show us the date on which you purchased your product when you make a claim under this warranty. Your owner's registration card filed online at www.wallmountwarranty.com or your contractor's invoice, bill of sale, or similar document is sufficient at time of warranty claim. This must be registered within 90 days of installation. If you can not show us the actual date of purchase, the time periods in this warranty will start on the date that we shipped your Bard product from our factory.

What This Warranty Does Not Cover: (Also see Duration of Warranty on reverse side.)

This warranty does not cover defects or damage caused by:

1. Alterations not approved by Bard; improper installation (including over or under sizing), improper repairs, or servicing; or improper parts and accessories not supplied by Bard.
2. Misuse or failure to follow installation and operating instructions (including failure to perform preventative maintenance) or limitations on the rating plate. This includes failure to use low ambient controls on all applications requiring compressor operation in cooling mode below 60F outdoor ambient.
3. Any corrosion from operation in a corrosive atmosphere (examples: acids, halogenated hydrocarbons or environmental conditions).
4. Parts that must be replaced periodically (such as filters, mist eliminators, ERV belts, pile seals, etc.).
5. Improper fuel or electrical supply (such as low voltage, voltage transients, power interruption, and units on generators with no brownout protection).
6. Accidents or other events beyond our reasonable control (such as storm, fire, or transportation damage).
7. Defects that happen after
 - (a) Anyone has tampered with the product.
 - (b) The product has been improperly serviced according to accepted trade practices;
 - (c) The product has been moved from its original place of installation; or,
 - (d) The product has been damaged by an event beyond Bard's control (See also No. 5 above).
8. Consequential damages (such as increased living expenses while the product is being repaired). Some states do not allow the exclusion or limitation of incidental or consequential damages, so the above limitation or exclusion may not apply to you.
9. This warranty has certain limitations for units installed on over-the-road trucks, vans and trailers. (See reverse side.)
10. Cost of service call at installation site to diagnose causes of trouble, labor to replace defective component or transportation costs for replacement parts.
11. This Limited Warranty does not apply to products installed or operated outside of the US, Puerto Rico, US Virgin Islands, Guam, Canada and Mexico. Units operated in coastal areas where the operating environment is exposed to airborne saline particles (typically 5 miles from coast line) must have corrosion protection or warranty claims will be declined on corrosion-based cabinet and part failures.
12. Bard does not endorse, approve or certify any online sales of its products through auction websites, online retailers, liquidators or any other method of online sales direct to consumers. Bard will not honor the factory warranty of any Bard equipment purchased over the Internet.

Your Responsibilities:

You are responsible for

1. Preventative maintenance of the product (such as cleaning coils and replacement of filters, nozzles and other consumable parts).
2. Ensuring that the instruction manual is followed for care and use of your product.
3. Ensuring that your product is installed by a competent, qualified contractor, following all local and national codes, and industry standards.

What Bard Will Do About A Defect:

Bard will either repair or replace the defective part only. Replacement parts may be reconditioned parts. The warranty for the repaired or replaced part will last only for the remainder of the warranty period for the original part.

Defective parts must be supplied to a Bard distributor who will then submit a parts warranty claim form. Credits are issued to the Bard distributor.

Bard will not pay or be responsible for labor or defective/replacement part transportation costs or delays in repairing or failures to complete repairs caused by events beyond our reasonable control.

What You Must Do

1. Tell your heating and air conditioning contractor as soon as you discover a problem and have the contractor make repairs.
2. Pay for all transportation, related service labor, diagnostic charges, refrigerant, refrigerant recovery and related items.

Service

If your product requires service, you should contact the contractor who installed it or the contractor that has been providing the product's preventative maintenance and repair service. You may find the installing contractor's name on the product or in your Owner's packet. If you do not know who that is, you should contact a competent, qualified contractor to make the repairs. If in doubt, you should contact the nearest distributor that handles Bard products (www.bardhvac.com). Please note that contractors and distributors that handle Bard products are independent contractors and distributors, and therefore, are not under the direction of Bard Manufacturing Company, Inc.

Only Warranty

There are no other express warranties. All implied warranties are limited in duration to the duration of the applicable written warranty made above.

Some states do not allow limitations on how long an implied warranty lasts, so the above limitation or exclusion may not apply to you.

Duration Of Warranty is limited to defects arising during the periods shown in the following table:

Model Number Series:	— Number of Years from Installation Date ① —			
	Compressor ④	Sealed System Components ②④⑤	All Other Functional Parts ③	Heat Exchangers
AIR CONDITIONERS W12A, W18A, W24A, W30A, W36A, W42A, W48A, W60A, W72A, W090A, W120A, W150, W180A, W18L, W24L, W30L, W36L, W3SA, W4SA, W5SA, Q36A, Q42A, Q48A, I30A, I36A, I42A, I48A, I60A	5	5	5	N/A
AIR SOURCE HEAT PUMPS W18H, W24H, W30H, W36H, W42H, W48H, W60H, C24H, C30H, C36H, C42H, C48H, C60H, T24H, T30H, T36H, T42H, T48H, T60H, T24S, T30S, T36S, T42S, T48S, T60S, Q24H, Q30H, Q36H, Q43H, Q48H, I30H, I36H, I42H, I48H, I60H, I36Z, I48Z, I60Z	5	5	5	N/A
ENVIRONMENTAL CONTROL UNITS W6RV, W6LV	5	5	1	N/A
AGRICULTURAL UNITS A36C and all HVAC equipment used in this application.	5	5	1	N/A
EQUIPMENT SHELTER UNITS MULTI-TEC, MEGA-TEC, FUSION-TEC, and all HVAC equipment used in this application.	5	5	1	N/A
GEOHERMAL/WATER SOURCE HEAT PUMPS QW2S, QW3S, QW4S, QW5S, QC50 (No Compressor)	5	5	5	N/A
GAS/ELECTRIC WALL-MOUNT W24G, W30G, W36G, W42G, W48G, W60G, WG3S, WG4S, WG5S	5	5	5	10
ACCESSORIES Factory/Field Installed Bard Ventilation and Heater Packages, Bard branded Thermostats/ Temperature Controllers, UV-C LED Light Kits, LC6000, LV1000, MC4002, DC3003, TEC40, BG1000, PGD, PGDX, MC5300, MC5600, Humidistats, CO2 Controllers, add-on controller/ther- mostat cards and all other field-installed accessories not listed separately	N/A N/A N/A N/A	N/A N/A N/A N/A	5 5 1 1	N/A N/A N/A N/A

- ① For equipment that does not have an online warranty registration, the warranty period starts when the product was shipped from the factory.
- ② Heat transfer coils (refrigerant to air coils for air source and coaxial coils for water source units) are covered for leaks for 5 years. Physical damage to air side coils resulting in leaks or insufficient airflow, or fin deterioration due to corrosive atmosphere (such as acids, halogenated hydrocarbons, agricultural or coastal environmental conditions) are not covered. Leaks in coaxial coils due to freezing of the coils are not covered. Copper coaxial coils for QW are not warranted for ground water/open loop installations.
- ③ Functional parts warranty is 1 year for all telecommunication, electric switch stations, pump stations, agricultural use, and similar applications. This also applies to all OTR (over the road) applications.
- ④ All OTR (over the road) applications that are moved from one location to another:
Factory Warranty applies up to the point of initial start-up and test at all OEM manufacturing locations or subsequent outfitting facility. Once it goes into OTR service, the warranty expires immediately for compressor and sealed system components. This OTR exemption does not apply to relocatable classrooms, construction, or office trailers.
- ⑤ Factory-coated coils have a "5" year warranty in corrosive environments that are listed as approved.



Internet Resources

Recognized as a leader in the HVAC industry, Bard combines quality products and outstanding service with innovation and technological advances to deliver high-performance heating and cooling products around the world. Please visit www.bardhvac.com for additional information regarding warranty and product information.