REPLACEMENT PARTS MANUAL

WALL MOUNTED GAS/ELECTRIC COMMERCIAL VENTILATOR

Model: **WGCRVS-3A**
WGCRVP-3A
WGCRVS-5A
WGCRVP-5A

General Notes

- Revised and/or additional pages may be issued from time to time.
- A complete and current manual consists of pages shown in the following contents section.

Important

- Contact the installing and/or local Bard distributor for all parts requirements. Make sure you have the complete model and serial number available from the unit rating plates.

Contents

Description	Page
Cabinet Components	
♦ Exploded View	2
♦ Usage List	2
Functional Components WGCRVP	
♦ Exploded View	3
♦ Usage List	3
Functional Components WGCRVS	
♦ Exploded View	4
♦ Usage List	4



Bard Manufacturing Company, Inc.
Bryan, Ohio 43506
Since 1914...Moving ahead just as planned.

Manual: 2110-1113
Supersedes: **NEW**
File: Vol II Tab 14
Date: 02-24-10

CABINET COMPONENTS

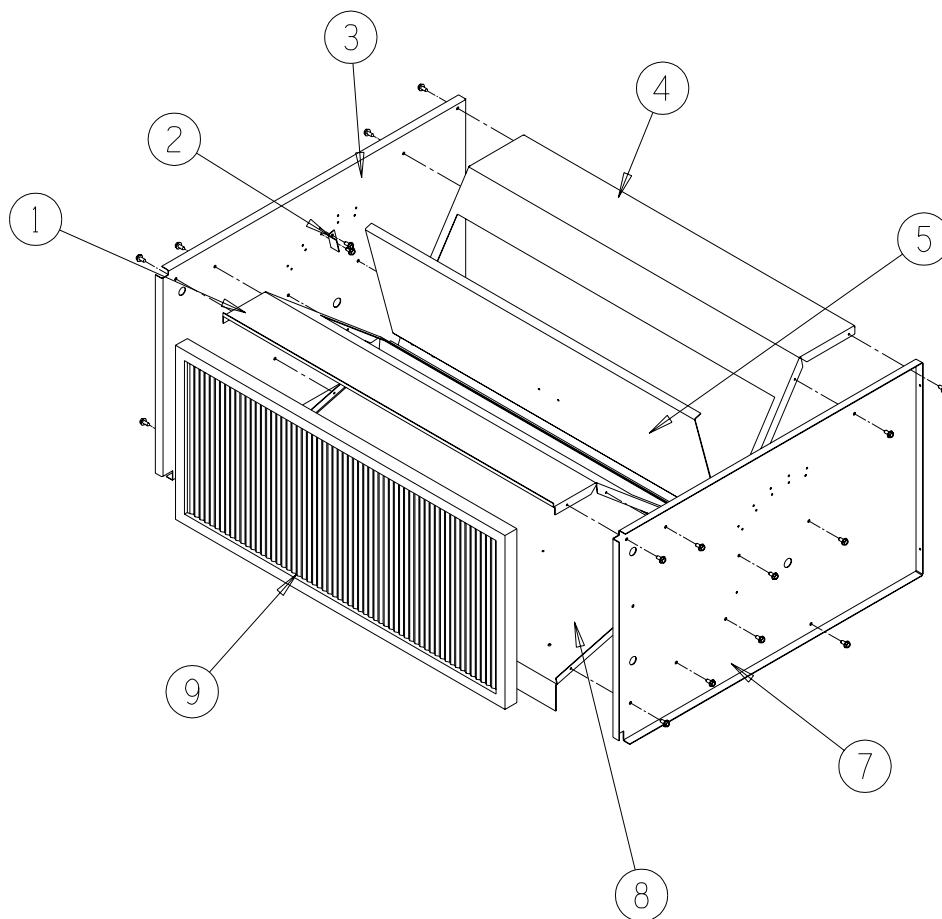

SEXP-358

Drawing No.	Part No.	Description	WGCRVS-3A	WGCRVP-3A	WGCRVS-5A	WGCRVP-5A
1	S137-457	Front Fill	X	X		
1	S137-442	Front Fill			X	X
2	131-095	Blade Stop		X		X
3	S101Y402	Left Side	X	X		
3	S101Y378	Left Side			X	X
4	S137-458	Rear Fill	X	X		
4	S137-464	Rear Fill			X	X
5	S139-162	Damper Blade	X	X		
5	S139-139	Damper Blade			X	X
7	S101X402	Right Side	X	X		
7	S101X378	Right Side			X	X
8	S127-322	Base	X	X		
8	S127-303	Base			X	X
9	7003-058	Mist Eliminator	X	X		
9	7003-054	Mist Eliminator			X	X
NS	136-459	Bottom Fill	X	X		
NS	136-465	Bottom Fill			X	X

FUNCTIONAL COMPONENTS

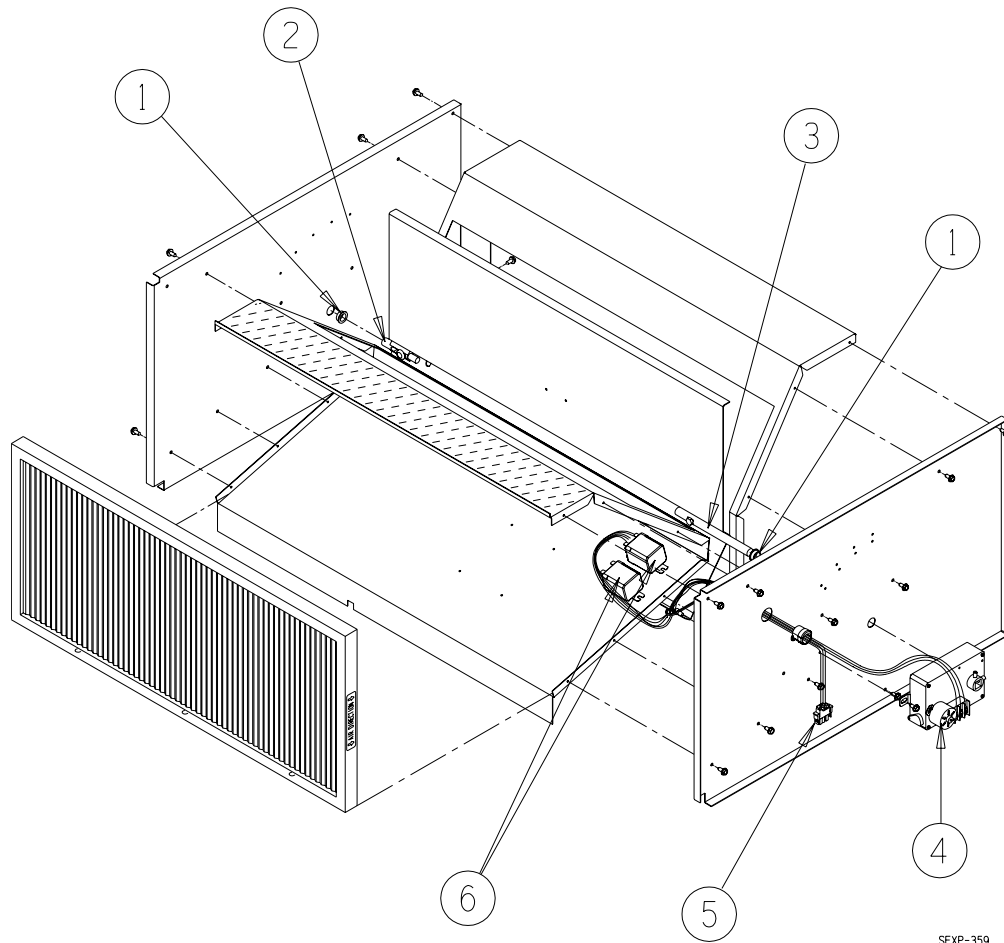

SEXP-359

Drawing No.	Part No.	Description	WGCRVP-3A	WGCRVP-5A
1	8602-052	Bushing	2	2
2	8602-038	Damper Blade Pin	X	X
3	8602-051	Shaft	X	X
4	8602-050	Damper Motor	X	X
5	3000-1321	Wire Assembly	X	X
6	8201-048	Relay	3	3

FUNCTIONAL COMPONENTS

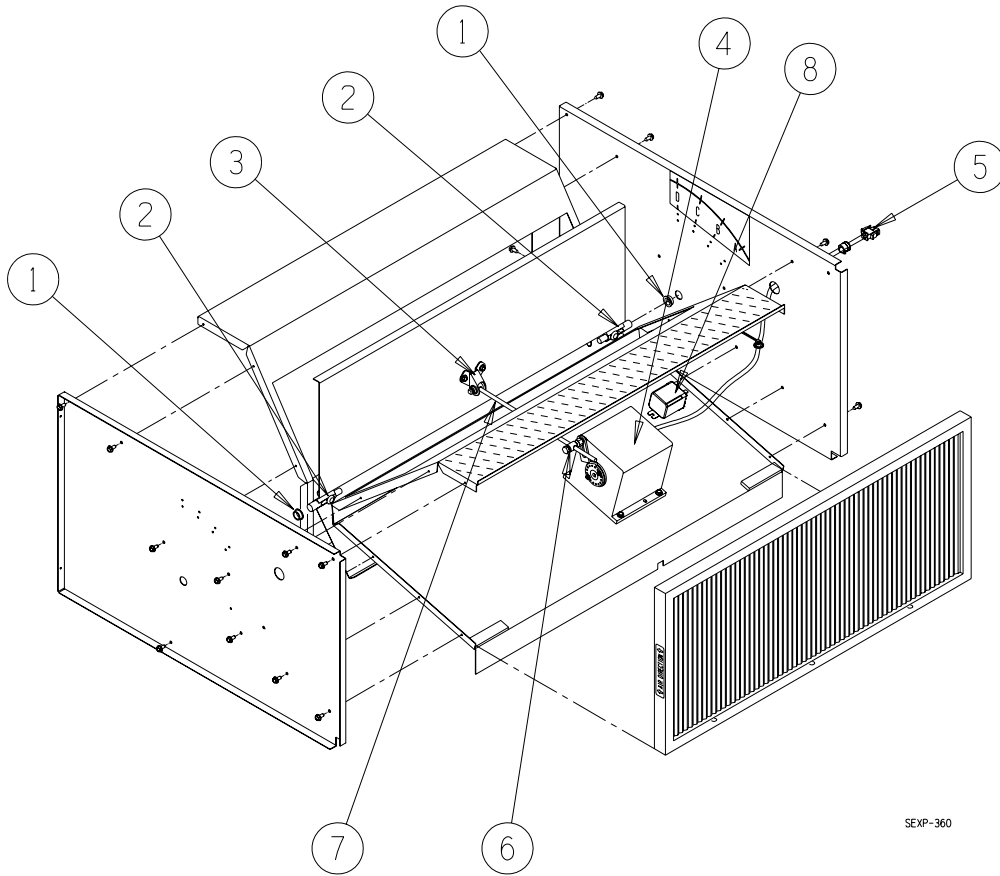

SEXP-360

Drawing No.	Part No.	Description	WGCRVS-3A	WGCRVS-5A
1	8602-052	Bushing	2	2
2	8602-038	Damper Blade Pin	2	2
3	8602-040	Bracket	X	X
4	8602-020	Damper Motor	X	X
5	3000-1320	Wire Assembly	X	X
6	8602-008	Ball Joint	X	X
7	8602-044	Rod	X	
7	8602-047	Rod		X
8	8201-098	Relay	2	2