

230-3-60
220-3-50
PER NAMEPLATE

265 JUMPER BAR 266

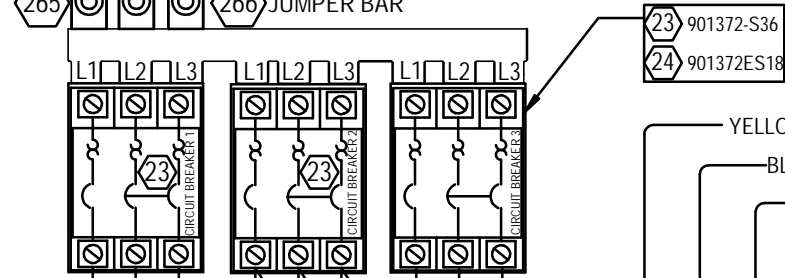

23 901372-S36
24 901372ES18

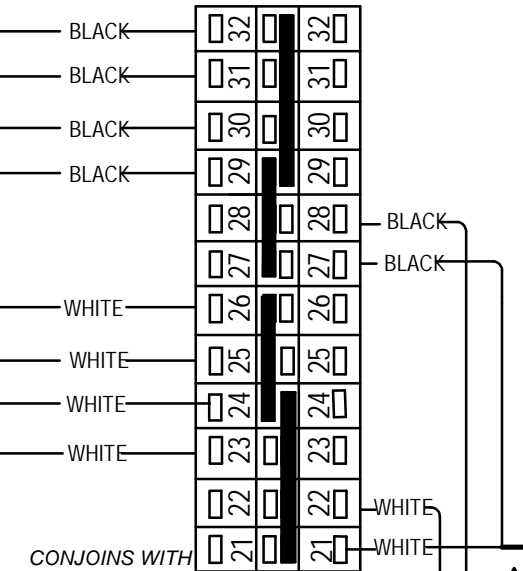
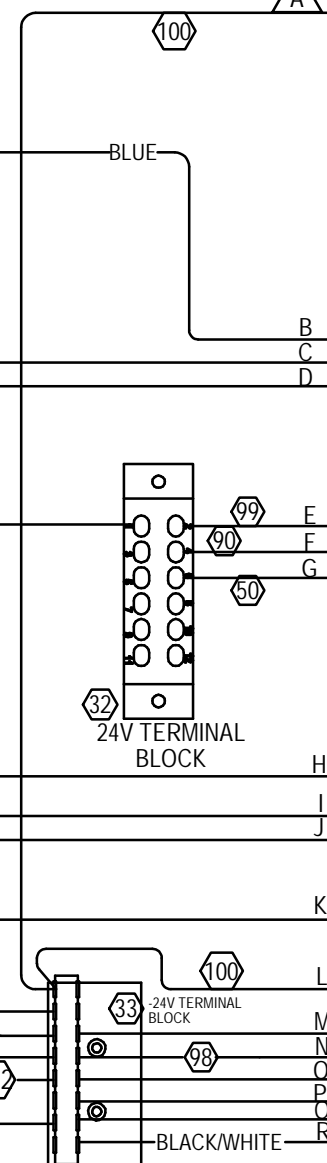
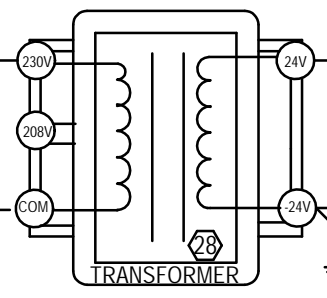
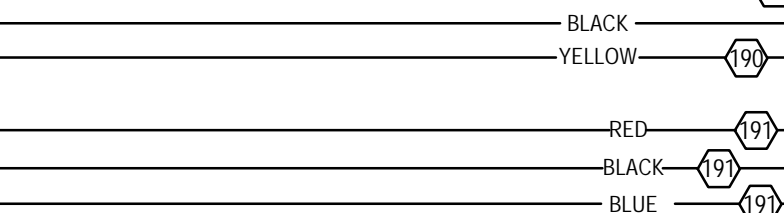
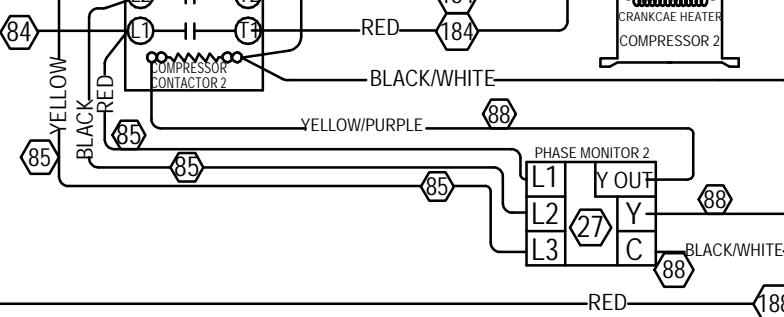
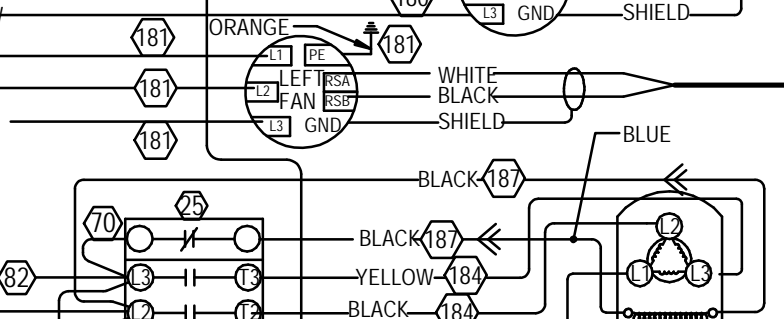
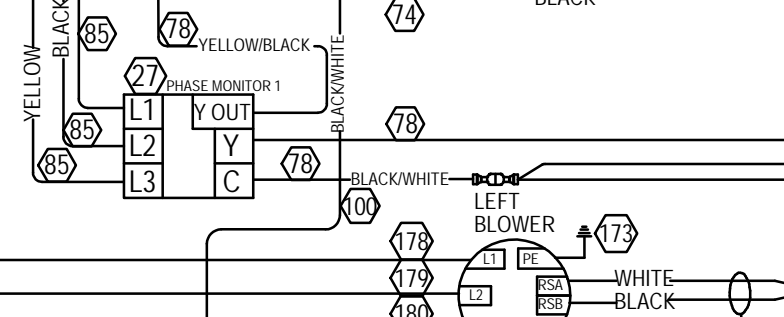
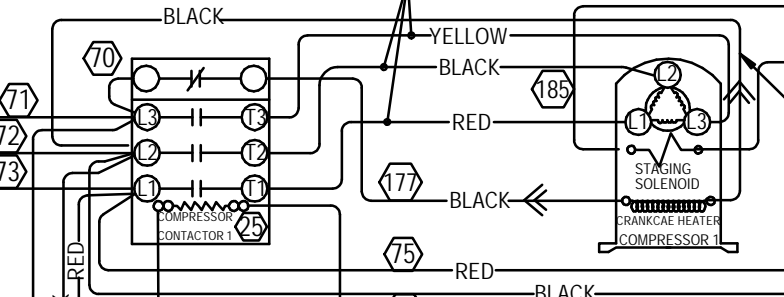
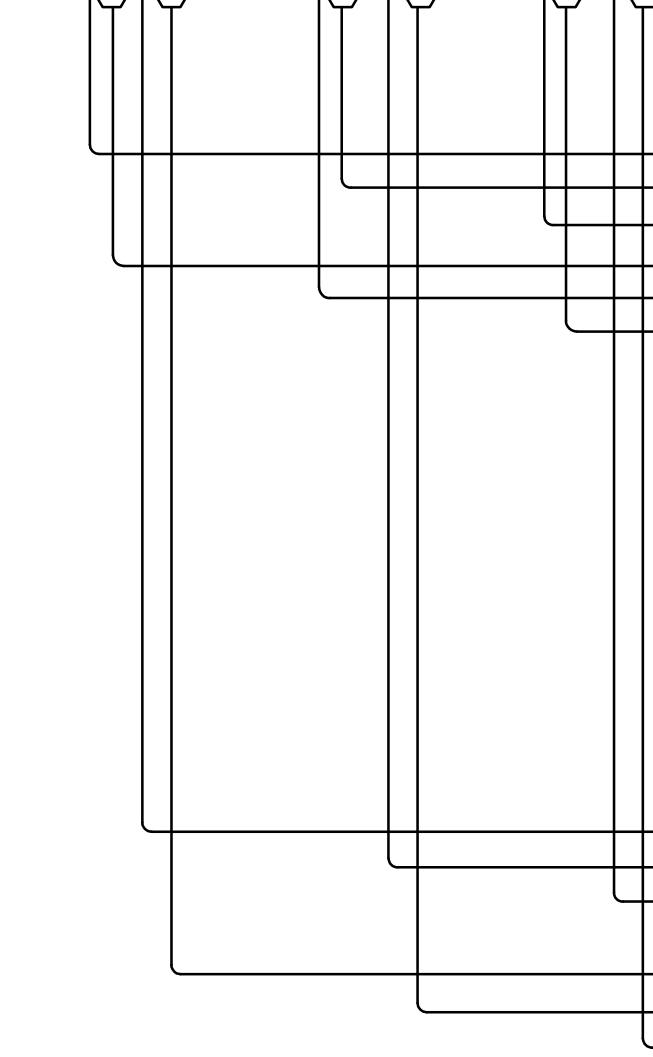
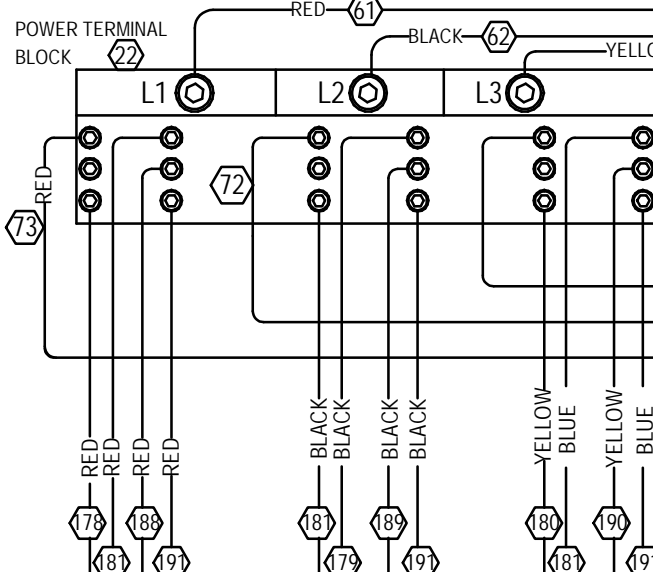
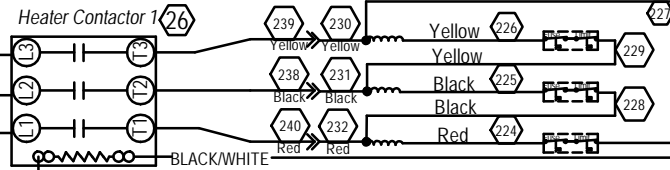

CONJOINS WITH
TERMINAL BLOCK
ON PAGE 2&3

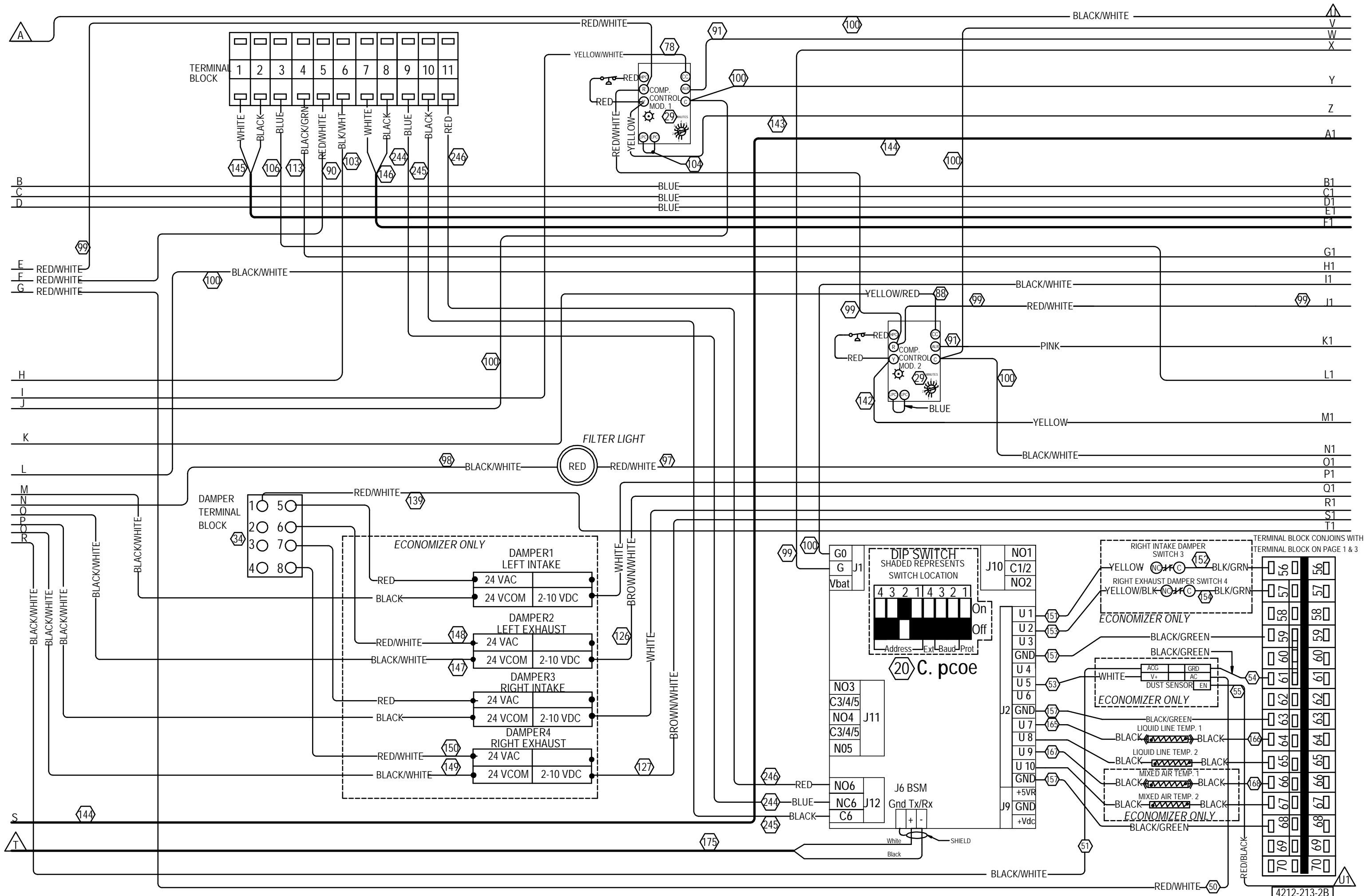

TERMINAL BLOCK

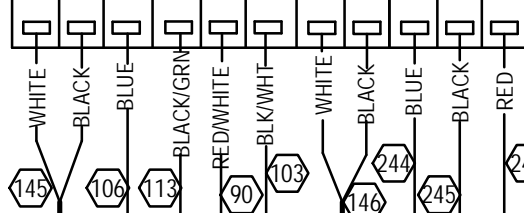

DAMPER TERMINAL BLOCK

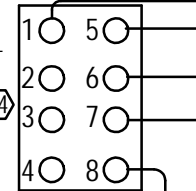

ECONOMIZER ONLY

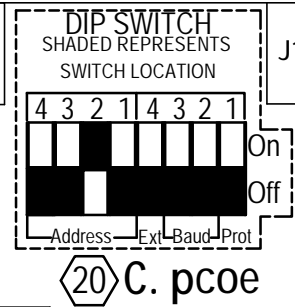
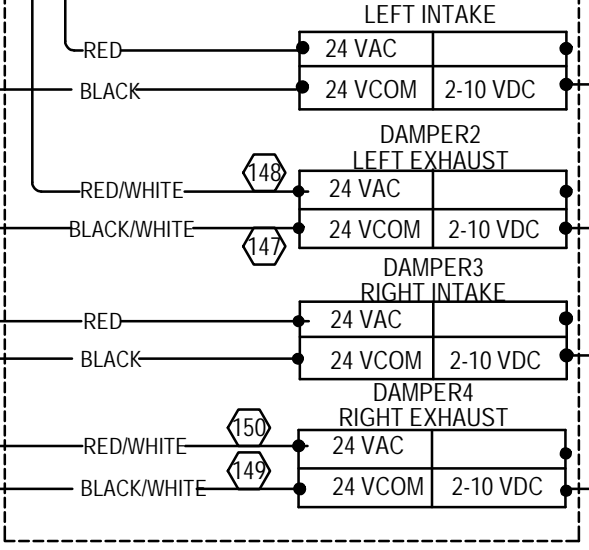

RIGHT INTAKE DAMPER SWITCH 3

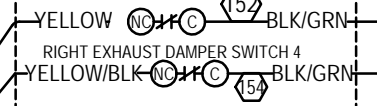

ECONOMIZER ONLY

RIGHT EXHAUST DAMPER SWITCH 4

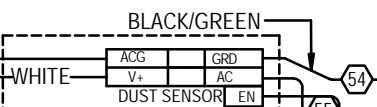

ECONOMIZER ONLY

BLACK/GREEN

LIQUID LINE TEMP. 1

LIQUID LINE TEMP. 2

MIXED AIR TEMP. 1

MIXED AIR TEMP. 2

ECONOMIZER ONLY

BLACK/GREEN

TERMINAL BLOCK CONJOINS WITH TERMINAL BLOCK ON PAGE 1 & 3

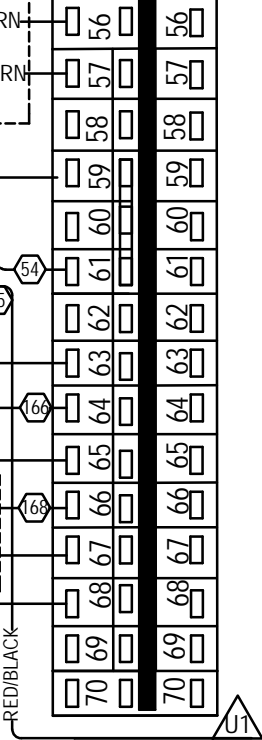

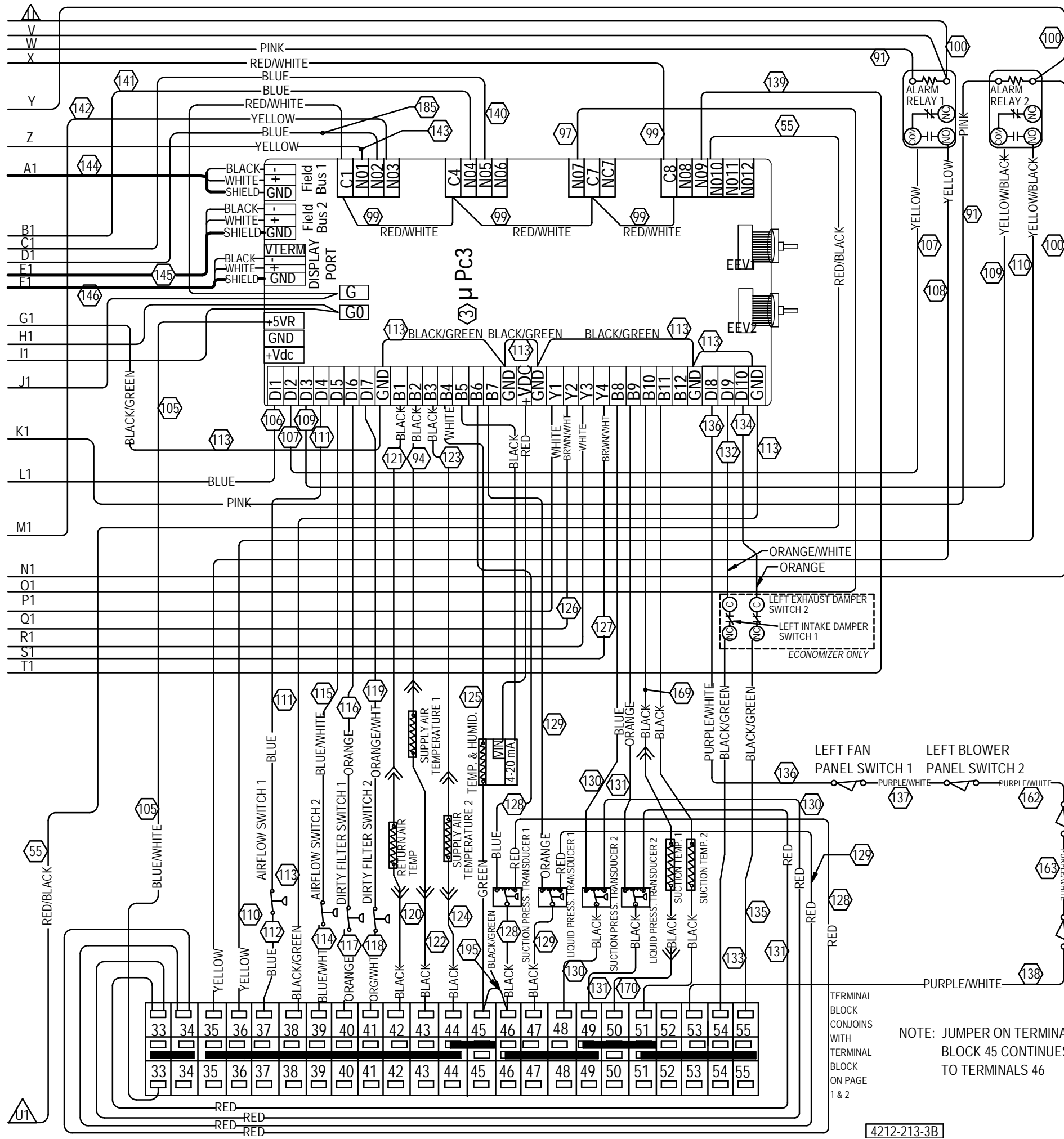

TERMINAL
BLOCK
CONJOINS
WITH
TERMINAL
BLOCK
ON PAGE
1 & 2

NOTE: JUMPER ON TERMINAL
BLOCK 45 CONTINUES
TO TERMINALS 46