

Climate Control Solutions
Bard Manufacturing Company
Bryan, Ohio 43506

INSTALLATION INSTRUCTIONS

CMA-10A

HIGH and LOW PRESSURE CONTROL and COMPRESSOR CONTROL MODULE WITH TIME DELAY

DESCRIPTION

The CMA-10A is a field installable high and low pressure control and compressor time delay relay control kit. The CMA-10A consists of:

1. Installation Instructions 7960-433
2. High Pressure Control 1804-0106
3. Low Pressure Control 1804-0107
4. Control Assembly 910-1404
5. Unit Label 7961-312-0114

For use with all WA181 – WA421 Hi-Boy Wall Mount air conditioners and WAG Hi-Boy Wall Mount air conditioners.

INSTALLATION INSTRUCTIONS (WA / WL SERIES ONLY)

Disconnect all power to unit. Remove control panel inner and outer covers and right side condenser inlet grille. Circled numbers on Figure 2 correspond to installation instruction steps.

- Step 1. Screw compressor control module into control panel as shown in Figure 2.
- Step 2. Disconnect yellow low voltage wire from compressor contactor and reconnect to terminal Y of the compressor control module.
- Step 3. Connect the yellow wire from the compressor control module to Y side of the compressor contactor coil. This is the same terminal from which the wire was removed in Step 2.
- Step 4. Connect the black wire from the compressor control module to common "C" side of the compressor contactor coil.
- Step 5. Connect red wire from compressor control module to 24V "R" side of the transformer.
- Step 6. Remove the sealing compound from around the compressor wires in the bottom of the control panel.
- Step 7. Route the high (red) and low (blue) pressure switch wires through the bushing in the bottom of the control panel. Connect

the low pressure switch wire to terminals LPC of the compressor control module. Connect the high pressure switch wires to terminals HPC of the compressor control module.

- Step 8. Replace sealing compound after routing the wires through the bushing.
- Step 9. Remove service port caps on both the suction and discharge lines. Install the high pressure switch on the discharge line with the flare tee adapter that is brazed to the controls. Install the low pressure switch on the suction line. Check for pressure at the flare tee dill valves after installation to insure that the dill valve in the unit service port was depressed by the flare tee connector. Check for leaks at the flare tee connectors. Replace service port caps on the flare tee service ports and tighten. See Figure 3.
- Step 10. Adjust the compressor time delay relay to the desired delay on break. Two minutes are recommended. This TDR is variable from 30 seconds to 5 minutes.
- Step 11. Recheck wiring. Refer to Figure 1. Reapply power to the unit. The delay on power up begins timing when low voltage power is supplied to the compressor control module through "C" and "R" terminals. The delay on power up time is 2 minutes plus 10% of the delay on break period. Energize 1st and 2nd stage cooling. Compressor should not start until the delay on power up has expired. The delay on break period begins whenever Y is de-energized. The time period for the delay on break period is set by the red knob. Run the unit for at least 5 minutes. The unit should not go into lockout.

During routine operation of the unit with no power interruptions the compressor will operate on demand with no delay
- Step 12. Apply "This unit equipped with CMA-10A control module." label to the inside of the inner control panel cover above the wiring diagram.
- Step 13. Replace all panels and covers. This completes installation.

FIGURE 1
WIRING DIAGRAM

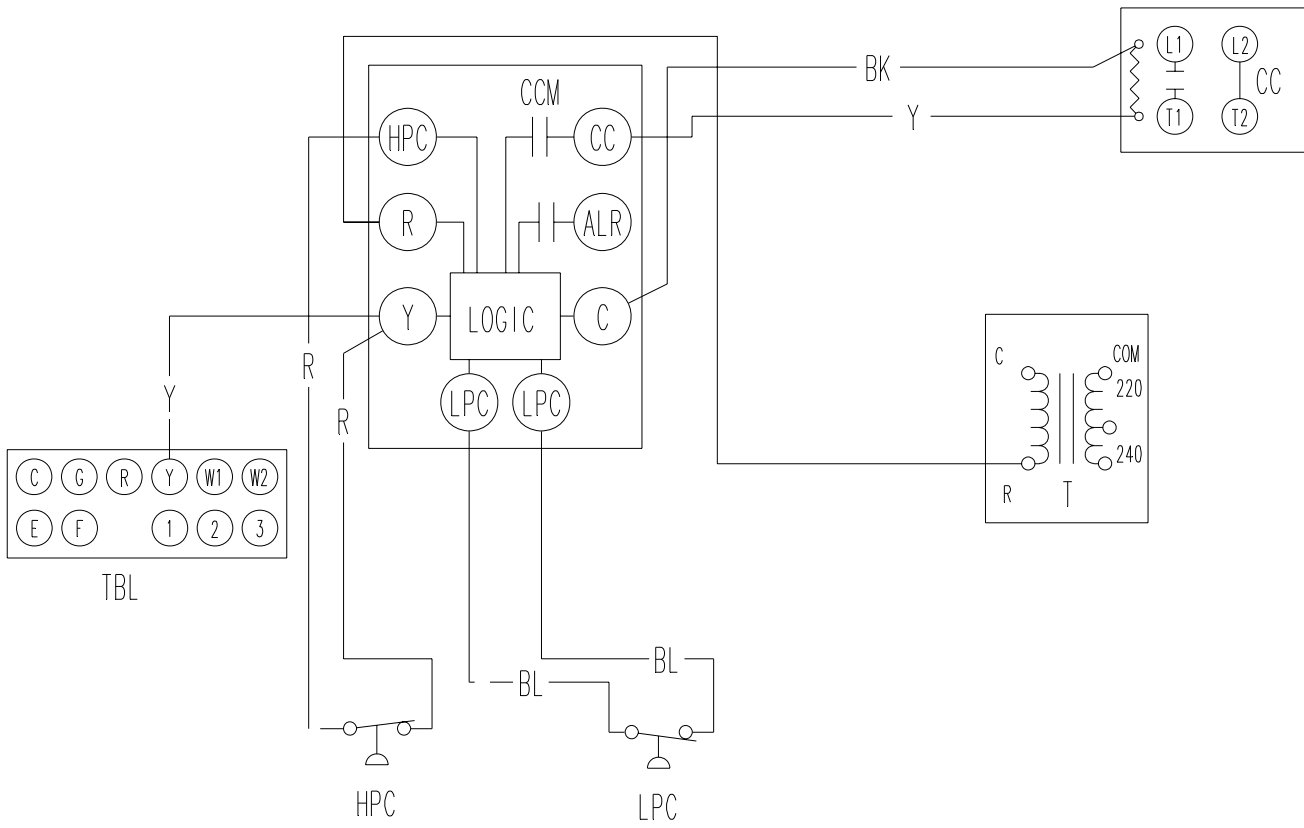

MIS-1280

FIGURE 2

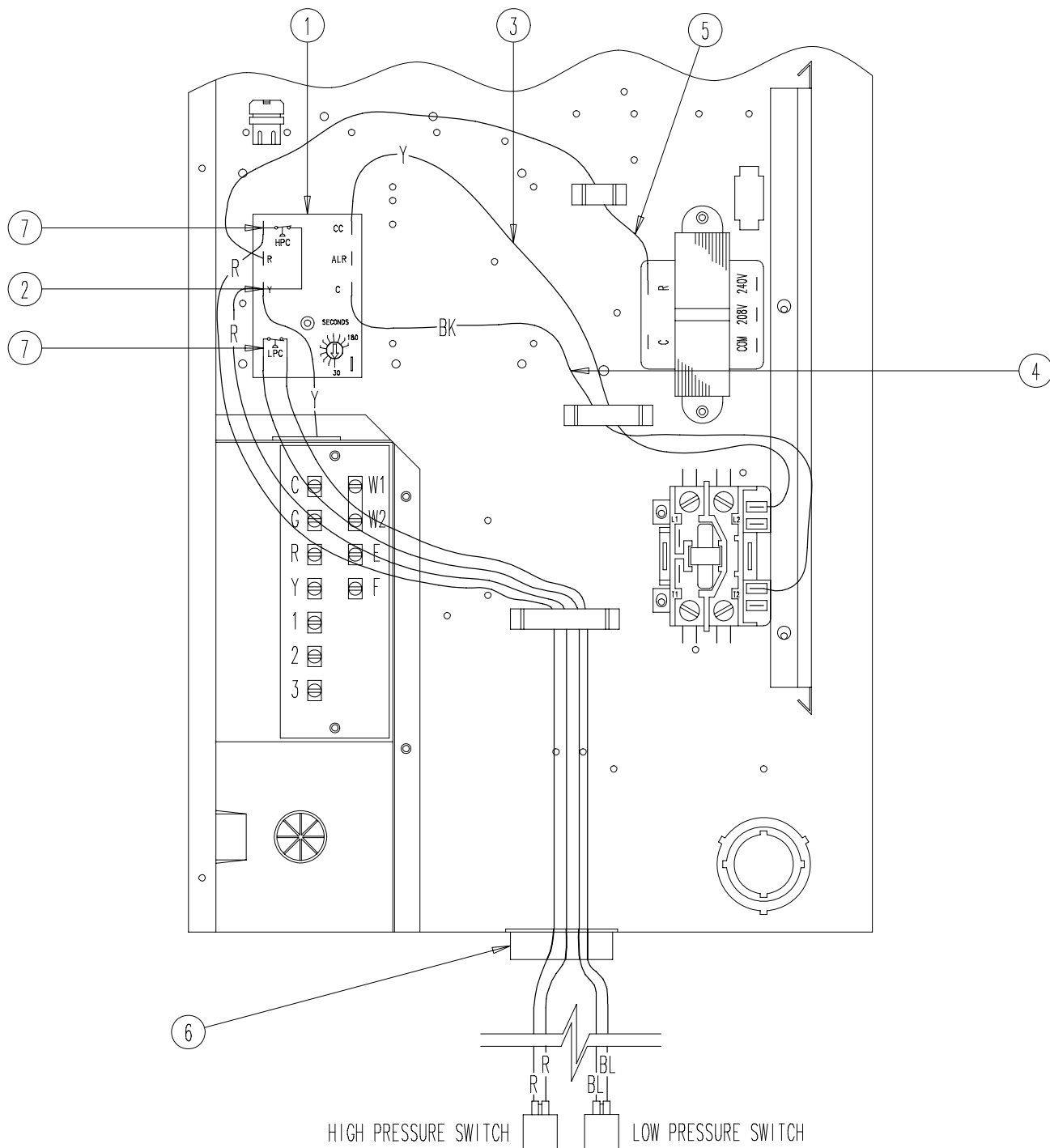

MIS-1281

FIGURE 3

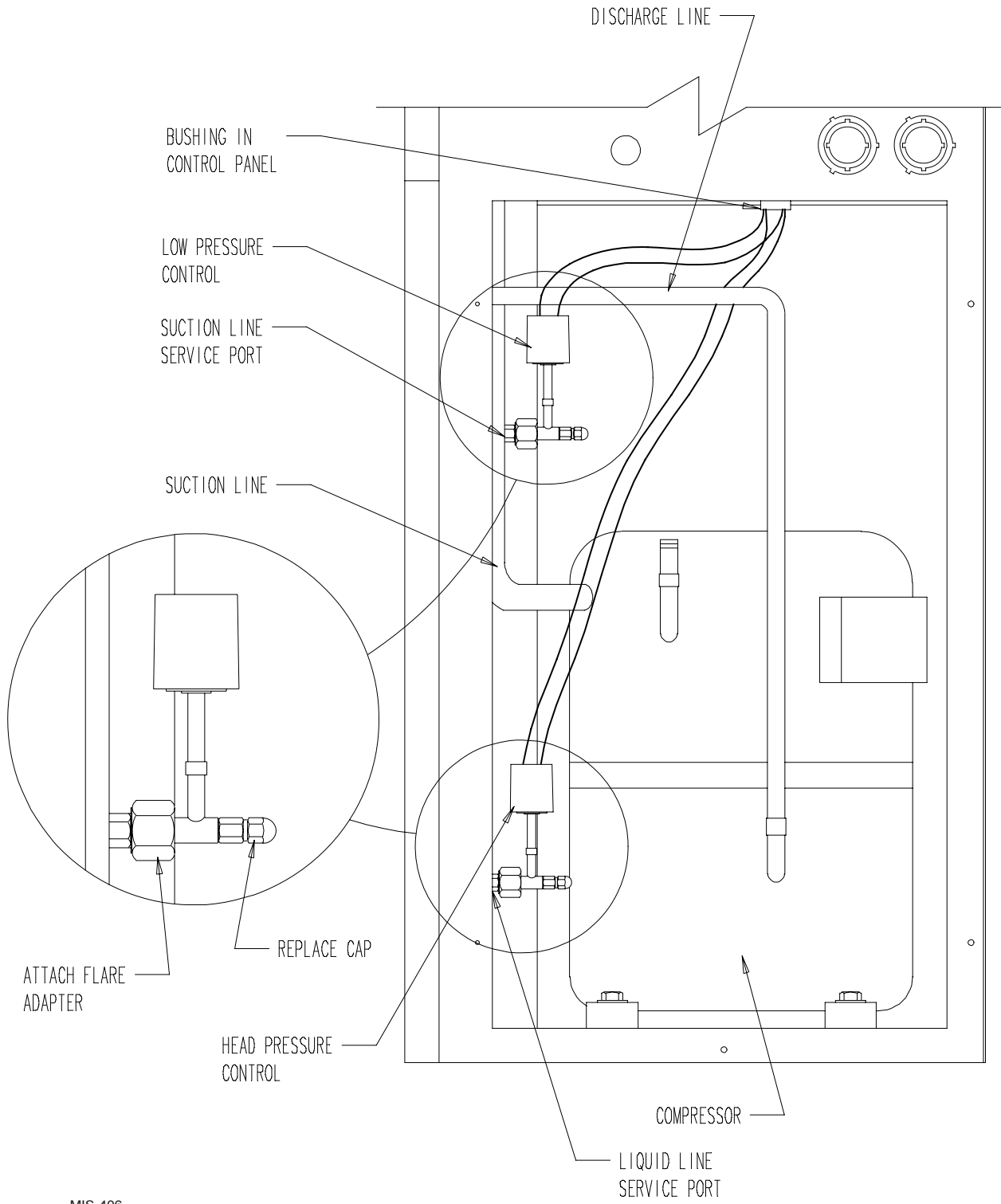

MIS-406

INSTALLATION INSTRUCTIONS (WAG GAS-ELECTRIC SERIES ONLY)

Disconnect all power to unit. Remove control panel inner and outer covers and right side condenser outlet grille. Circled numbers on Figure 4 correspond to installation instruction steps. Dashed wires indicate that a wire has been disconnected from this terminal.

- Step 1. Screw compressor control module into control panel as shown in Figure 4.
- Step 2. Disconnect yellow low voltage (Y) wire from the compressor contactor coil and reconnect to terminal "Y" on the compressor control module.
- Step 3. Connect yellow wire from terminal "CC" of the compressor control module to the (Y) terminal of the compressor contactor.
- Step 4. Connect the black wire from terminal "C" of the compressor control module to the common side of the compressor contactor.
- Step 5. Remove hole plug in the control panel. Route the low (blue) pressure switch wires up through the bushing in the compressor partition. Route high (red) and low (blue) pressure switch wires through the back of the control panel.
- Step 6. Connect the high pressure switch wires to the HPC terminals of the compressor control module.
- Step 7. Connect the low pressure switch wires to the LPC terminals of the compressor control module.
- Step 8. Remove the service port caps on the suction and liquid lines. Install the high pressure switch on the liquid line with the flare tee adapter that is brazed to the controls. Install the low pressure switch on the suction line. Check for pressure at the flare tee dill valves after installation to insure that the flare tee connector depressed the dill valve in the unit service port. Check for leaks at the flare tee connectors. Replace service port caps on the flare tee service ports and tighten.
- Step 9. Adjust the compressor time delay to the desired delay on start up. This TDR is adjustable from 30 to 180 seconds.
- Step 10. Recheck wiring. Refer to Figure 1. Energize the unit in first stage cooling. The compressor should not start until the time delay has expired. Run the unit for at least five minutes. The unit should not go into lockout.
- Step 11. Apply "*This unit equipped with CMA-10A control module.*" label to the inside of the inner control panel cover above the wiring diagram.
- Step 12. Replace all panels and covers. This completes the installation.

FIGURE 4

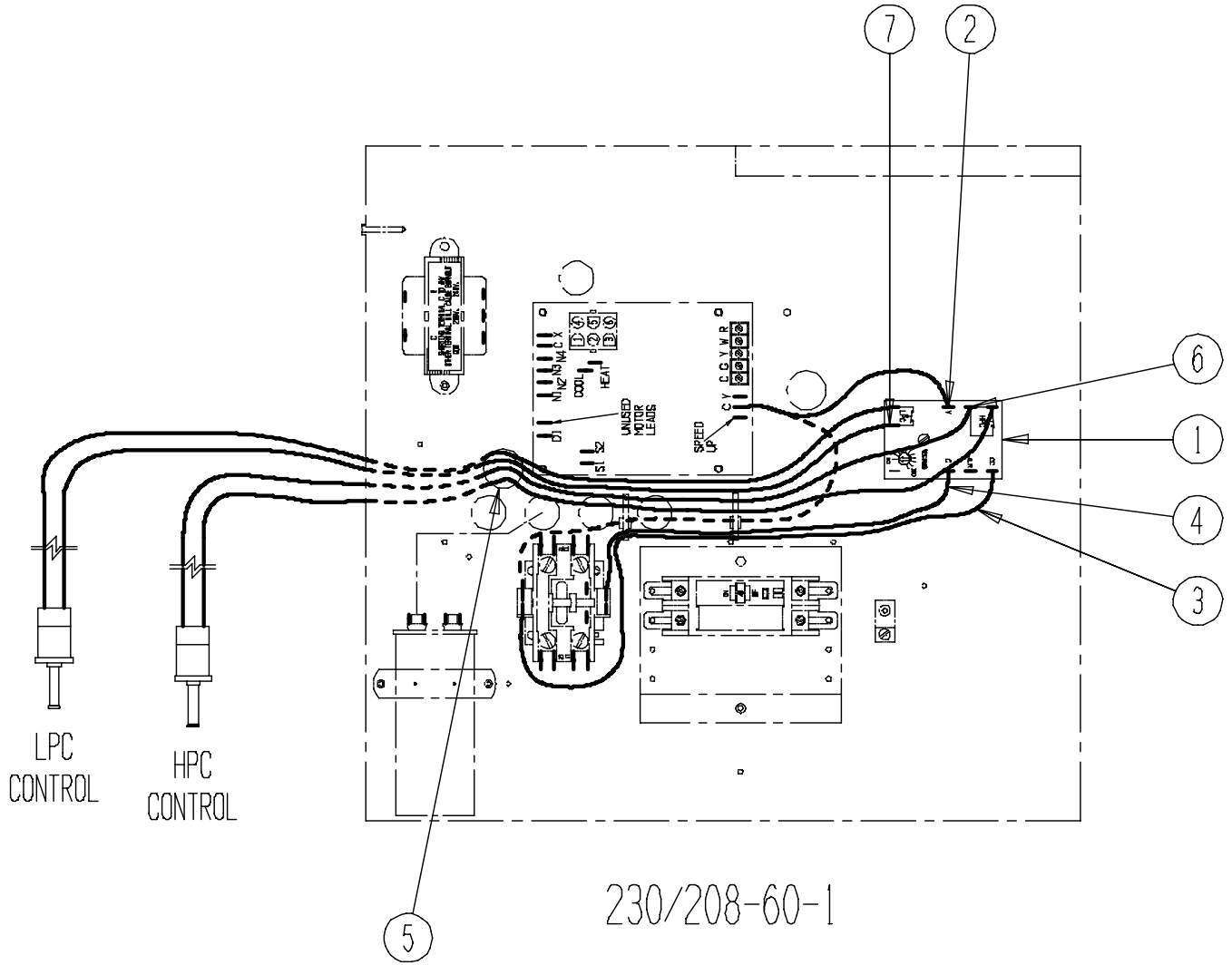

MIS-1273

FIGURE 5

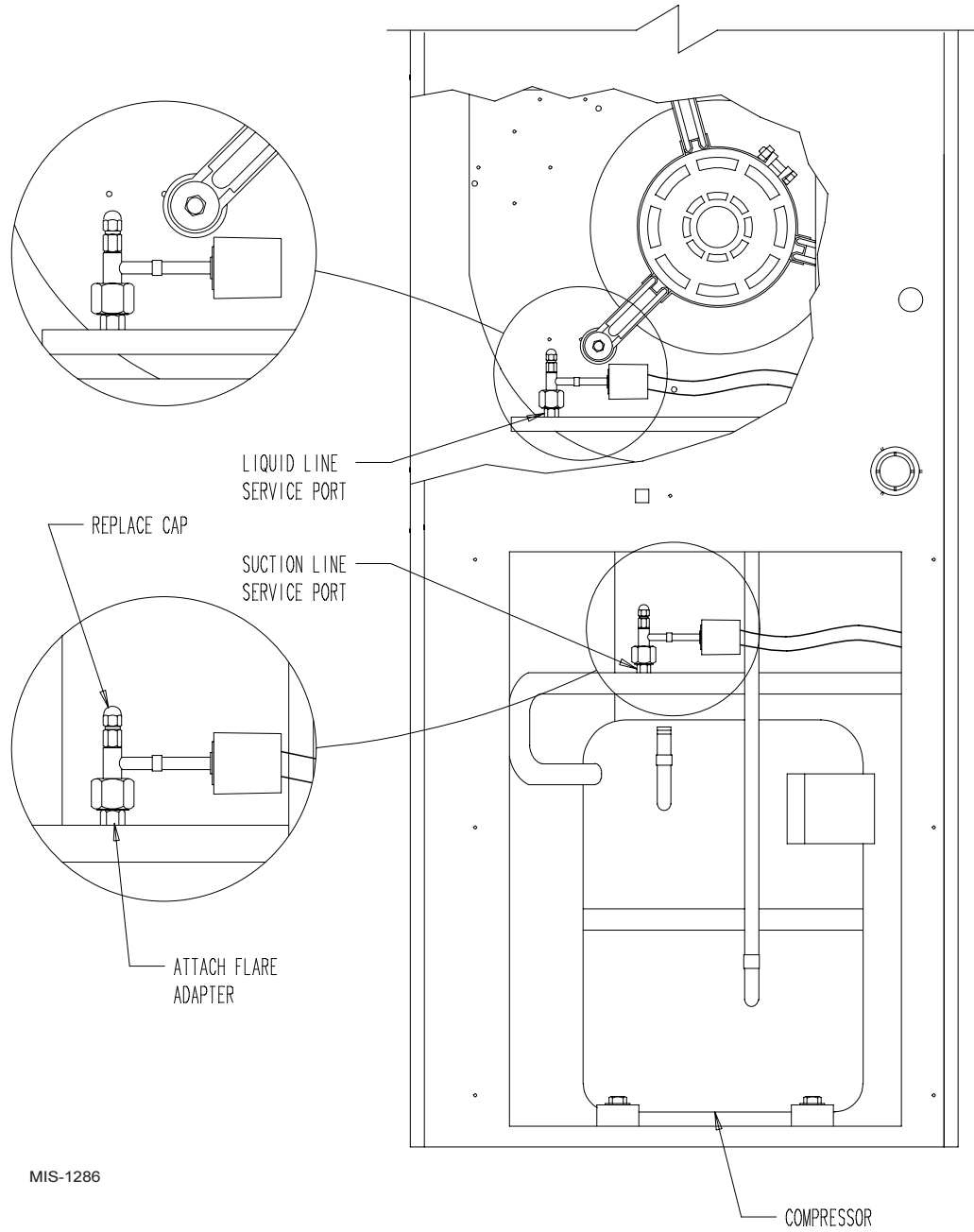

MIS-1286