



Climate Control Solutions

Bard Manufacturing Company, Inc.

Bryan, Ohio 43506

MODEL: ISTZ4-X, ISTZ4-1, ISTZ4-4 Side Trim Kit



MODEL FEATURES

The ISTZ4 Side Trim Extension Kit is designed for use with IZ Series Heat Pumps. By using this kit, the installer will be able to fill a 4" minimum to 4 $\frac{3}{8}$ " maximum gap between the back of the IZ Heat Pump to the front mounting wall surface in a room with a maximum ceiling height of 12'.

DESCRIPTION

The following 4" Side Trim Kit models are available:

ISTZ4-X (Beige Paint)

ISTZ4-1 (White Paint)

ISTZ4-4 (Buckeye Gray Paint)

The following tools will be required for installation of the trim kit (not provided):

- Sheet metal cutting tool such as tin snips, aviation snips, metal nibbler or electric shears (recommended)
- Tape Measure
- Alcohol pad or non-residue cleaner and cleaning cloth

Before starting, unwrap packaging and verify the following contents (see figure 1):

- 72" Side Trim with adhesive tape, 4 pieces, Balloon #1
- 144" Black rubber edge guard with wiper, 2 pieces, Balloon #2
- 1 $\frac{1}{2}$ " x 3 $\frac{3}{8}$ " connector plate with adhesive tape, 2 pieces, Balloon #3

INSTALLATION PROCEDURES

1. First measure the distance between the back of unit side and the wall. If this distance is less than 3 $\frac{3}{4}$ " the width of the side trim pieces will need adjusted appropriately. The minimum gap distance the trim kit can be used for is $\frac{5}{8}$ ".
2. Measure height of area requiring trim piece. If this measurement is a distance from floor to ceiling, reduce total height by $\frac{1}{8}$ " for clearance installation purposes when installing trim piece. Record total trim height measurement for future use in process.
3. Place two (2) 72" Side Trim pieces paint textured side down on large flat work area and clean primer metal surface with rubbing alcohol pad or non-residue cleaner. This will help adhesive tape bond to metal surface.
4. Align trim pieces together so ends are flush with both sides parallel. Remove adhesive tape from back of connector plate. Apply connector plate to cleaned, primed surface while ensuring trim piece ends are flush. Apply adequate pressure to area to form bond.
5. Measure and mark total trim height measurement on primer side of piece. Using sheet metal cutting tool, remove excess metal trim from one end.
6. Cut black rubber edge guard piece to total trim height measurement. Apply edge guard to trim assembly on "non-offset" side of part with rubber wiper facing down while trim piece is resting on the work surface painted textured side down.
7. Prepare IZ Heat Pump back corner by cleaning surface with alcohol pad or non-residue cleaner and cleaning cloth.
8. Take completed side trim assembly to unit installation and remove adhesive backing. Attach trim assembly flush 45° with unit back corner. Apply adequate pressure to form bond between trim assembly and unit side.
9. Repeat process for side trim assembly and installation on opposite rear corner of IZ Heat Pump.

FIGURE 1

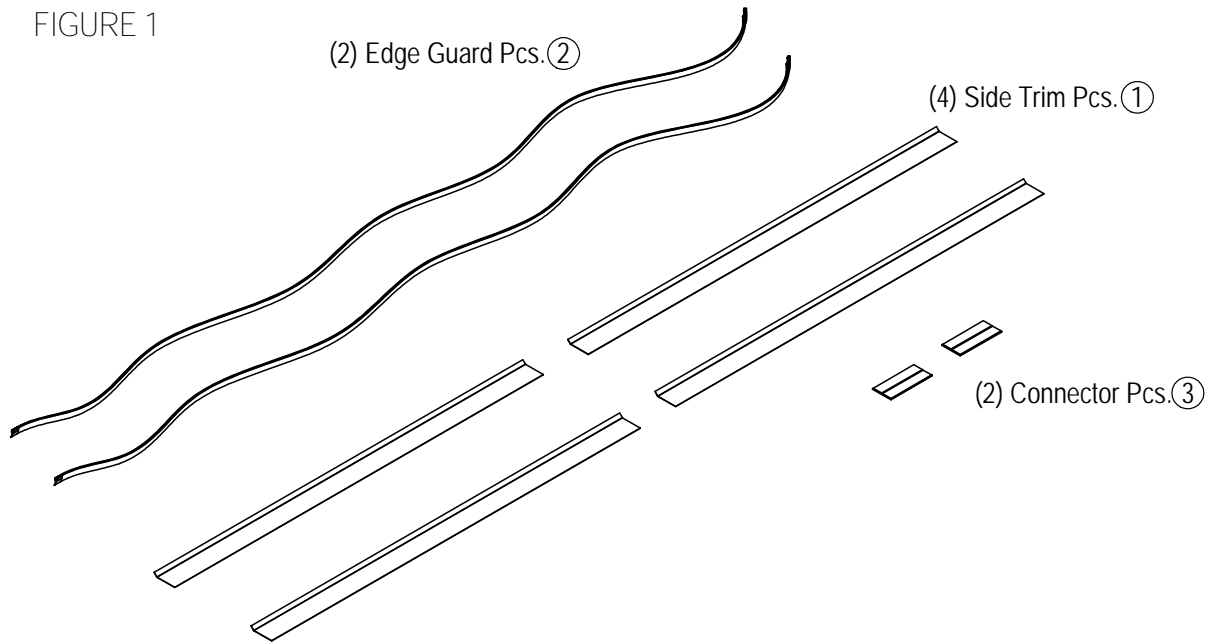
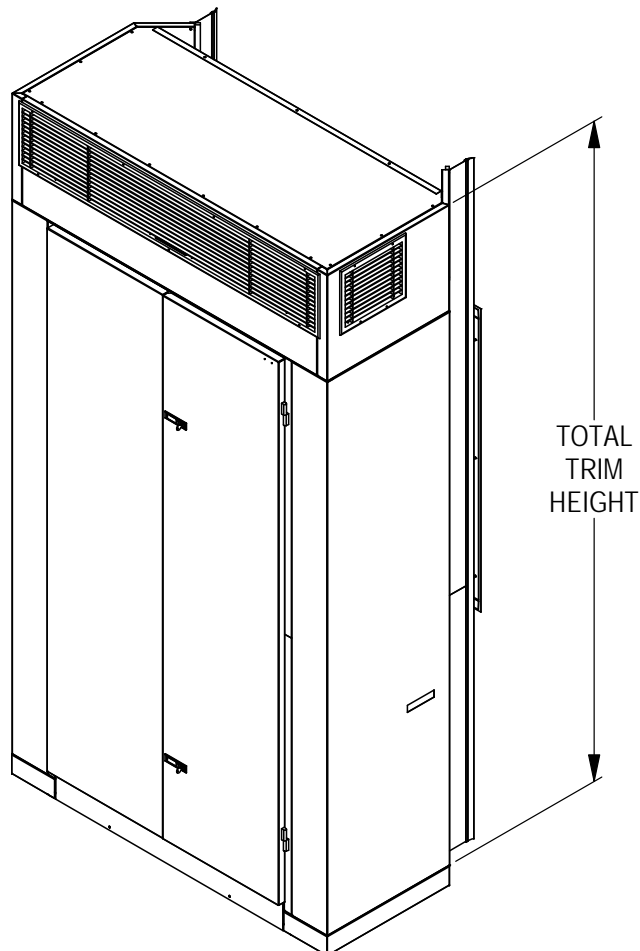

FIGURE 2



MIS-3243

FIGURE 3

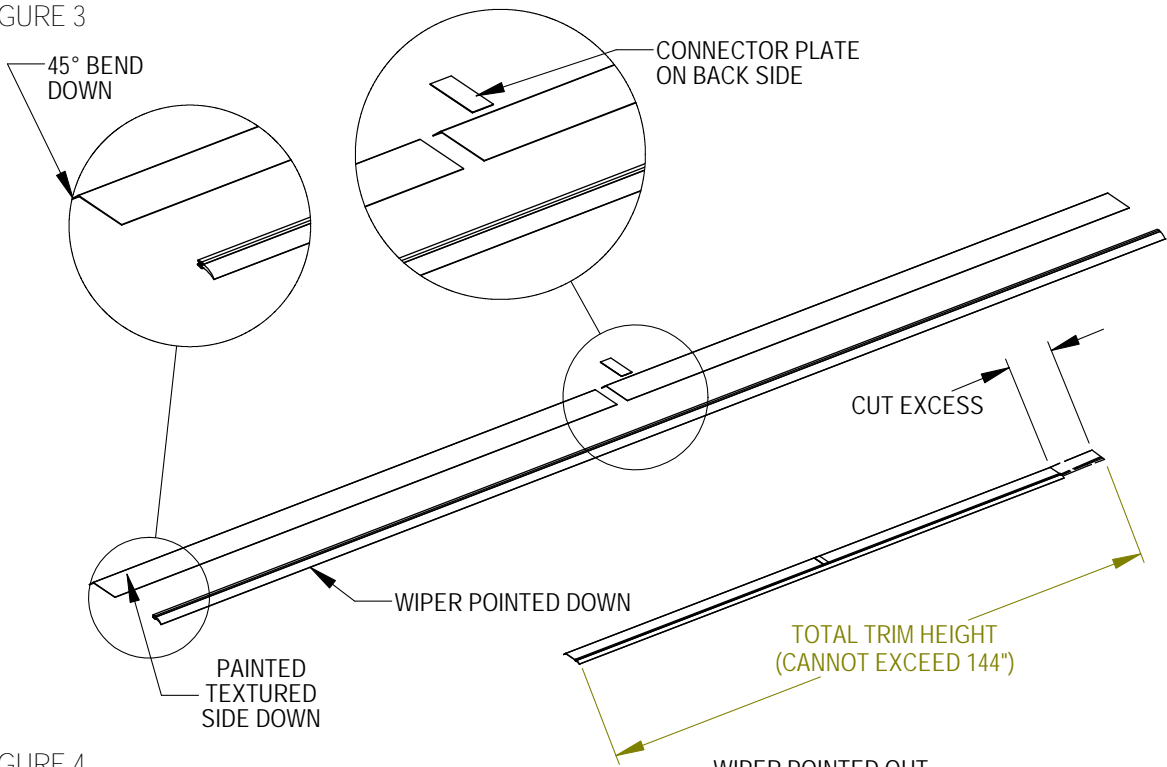
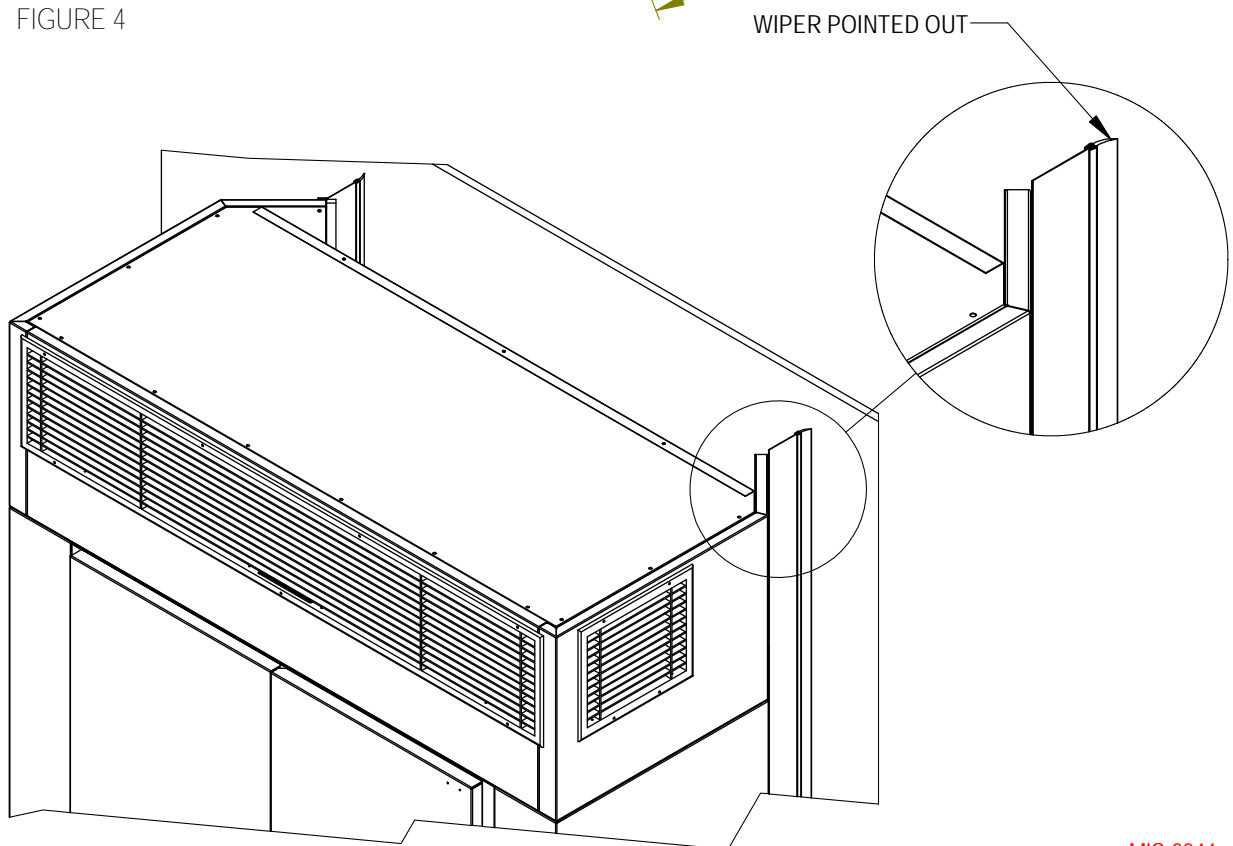

FIGURE 4



MIS-3244