



THE WALL-MOUNT™ ONE TON AIR CONDITIONER

W12AAA **60Hz**
12,000 Btuh **10.00 EER**
Right Side Control Panel

GREEN REFRIGERANT
R-410A

The Bard Wall-Mount One Ton Air Conditioner is a self contained energy efficient heating and cooling system, which is designed to offer maximum indoor comfort at a minimal cost without using valuable indoor floor space or outside ground space. The One Ton is the ideal product for versatile applications such as: new construction, modular offices, school modernization, telecommunication structures, portable structures or correctional facilities. Factory or field installed accessories are available to meet specific job requirements.

Engineered Features

Aluminum Finned Copper Coils

Rifled tubing and enhanced louvered fin for maximum heat transfer and energy efficiency.

Quiet Twin Blowers:

Designed to accept full ducted system or for non-ducted free blow installations.

High Efficiency Rotary Compressor

R-410A Refrigerant:

Designed with R-410A (HFC) non-ozone depleting refrigerant in compliance with the Montreal protocol and 2010 EPA requirements.

Liquid Line Filter Drier:

Standard on all units. Protects system against moisture.

Galvanized 20 Gauge Zinc Coated Steel Cabinet:

Cleaned, rinsed, sealed and dried before the polyurethane primer is applied. The cabinet is handsomely finished with a baked on textured enamel, which allows it to withstand 1000 hours of salt spray tests per ASTM B117-03.

Electrical Components:

Are easily accessible for routine inspection and maintenance through a right side, service panel opening.

Circuit Breaker:

Standard on 230/208 Models.

One Inch, Disposable Air Filter:

Easily removed for replacement from the outside. Optional two-inch pleated filter, factory or field installed.

Top Rain Flashing:

Standard feature on all models.

Slope Top:

Standard feature for water run-off.

Compressor Control Module:

Standard on all units. Built-in off-delay timer adjustable from 30 seconds to 5-minutes. 2-minute on-delay if power interrupt. 120-second bypass for low pressure control, and both soft and manual lockouts for high and low pressure controls. Alarm output for alarm relay.

High & Low Pressure Switches are Auto-Reset:

Standard on all units. Built-in lockout circuit resets from the room thermostat. Provides commercial quality protection to the compressor.

Barometric Fresh Air Damper:

Allows up to 100 CFM of fresh air.

Full Length Mounting Flanges:

Built into cabinet for improved appearance and easy installation.



Optional Product Features

Alarm Relay:

Dry contacts for remote alarm on high or low pressure lockouts.

Low Ambient Control:

Permits operation down to 0°F outdoor ambient. Can be factory or field installed.

Fully Modulating Economizer:

Can be factory or field installed.

Commercial Room Ventilator:

Can be factory or field installed.

- Complies with efficiency requirements of ANSI/ASHRAE/IESNA 90.1-2013.
- Certified to ANSI/ARI Standard 390-2003 for SPVU (Single Package Vertical Units).
- Intertek ETL Listed to Standard for Safety Heating and Cooling Equipment ANSI/UL 1995/CSA 22.2 No. 236-05, Fourth Edition.
- Commercial Product - Not intended for Residential application.



Capacity and Efficiency Ratings

Models	Volts	Phase	Heat Strip	Cooling Cap BTUH ①	EER ②
W12AAAAOZ	230/208	1	NONE	12,000	10.0
W12AAAA03	230/208	1	3.6 KW	12,000	10.0
W12AAAA05	230/208	1	5.0 KW	12,000	10.0
W12AAAK00	115	1	NONE	12,000	10.0
W12AAAK02	115	1	2.2 KW	12,000	10.0

① Capacity is certified in accordance with ANSI/ARI Standard 390-2003.

② EER = Energy Efficiency Ratio and is certified in accordance with ANSI/ARI Standard 390-2003.

All ratings based on fresh air intake being 100% closed (no outside air introduction).

Electrical Specifications

Models	Rated Volts and Phase	Operating Voltage Range	No. Field Power Circuits	Minimum Circuit Ampacity ③	Maximum External Fuse ① or Circuit Breaker	Field Power Wire Size ②	Ground Wire Size ②
W12AAAAOZ ④	230/208-1	197-253	1	9	15	14	14
A03 ④			1	20	20	12	12
A05 ④			1	27	30	10	10
W12AAAK00	115-1	104-126	1	17	30	10	10
K02			1	26	30	10	10

① Maximum size of the time delay fuse circuit breaker for protection of field wiring conductors.

② Based on 75°C copper wire. All wiring must conform to NEC and all local codes.

③ These "Minimum Circuit Ampacity" values are to be used for sizing the field power conductors.

Refer to the National Electrical Code (latest revision), article 310 for power conductor sizing.

④ Internal circuit breakers are standard on W12AAAA models.

CAUTION! When more than one field power conductor circuit is run through one conduit, the conductors must be derated. Pay special attention to note 8 of table 310 regarding Ampacity Adjustment Factors when more than 3 conductors are in a raceway.

Specifications

Models	Electrical Rating - 60 Hz	Compressor		Outdoor Fan Motor		Indoor Blower Motor		CFM / ESP (Rated-WET Coil)	Shipping Weight
		RLA	LRA	HP-RPM-SP	FLA	HP-RPM-SP	FLA		
W12AAAA	230/208-1	4.8 / 5.2	26	1/12-1075-1	.70	1/8-1650-1	.70	400/.20	185 lbs.
W12AAAK	115-1	9.1	57	1/12-1075-1	1.60	1/8-1650-1	1.40	400/.20	185 lbs.

Electric Heat Table

Models	W12AAAA				W12AAAK	
	240V-1		208V-1		120V-1	
	KW	AMPS	BTUH	AMPS	BTUH	AMPS
3.0	15.0	12,285	13.0	9,230	-	-
5.0	20.8	17,065	18.1	12,800	-	-
2.0	-	-	-	-	18.3	7,510

Indoor Blower Performance - CFM at 230 Volts

E.S.P. in H2O	High Speed Dry/Wet Coil
.0	525/500
.1	475/450
.2	425/400
.3	375/360
.4	315/300

Cooling Application Data - Outdoor Temperature °F ①

Model	Return Air (DB/WB) ②	Cooling Capacity	75°F	80°F	85°F	90°F	95°F	100°F	105°F	110°F	115°F	120°F
W12AAA	75/62	Total Cooling	14,100	13,100	12,200	11,300	10,500	9,800	9,100	8,500	7,900	7,400
		Sensible Cooling	10,900	10,400	9,900	9,500	9,200	8,800	8,500	8,100	7,700	7,300
	80/67	Total Cooling	15,000	14,200	13,500	12,700	12,000	11,400	10,700	10,100	9,500	8,900
		Sensible Cooling	10,500	10,200	9,800	9,500	9,200	8,900	8,700	8,500	8,300	8,100
	85/72	Total Cooling	17,900	16,600	15,500	14,400	13,400	12,500	11,600	10,800	10,000	9,300
		Sensible Cooling	10,800	10,400	9,900	9,500	9,100	8,700	8,300	8,000	7,700	7,400

① Below 55°F, unit requires a factory or field installed low ambient control.

② Return air temperature °F.

Capacity Multiplier Factors			
% of Rated Airflow	-10	Rated	+10
Total BTUH	0.975	1.0	1.02
Sensible BTUH	0.950	1.0	1.05

Ventilation System Packages

Bard Wall-Mounts are designed to provide optional ventilation packages to meet all of your ventilation and indoor air quality requirements. All units are equipped with a barometric fresh air damper as the standard ventilation package. All ventilation packages can be built-in at the factory or field-installed at a later date.

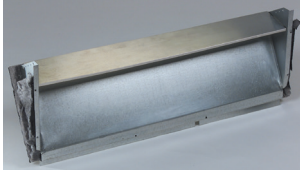

Barometric Fresh Air Damper

BAROMETRIC FRESH AIR DAMPER — BFAD-1

STANDARD

The barometric fresh air damper is a standard feature on all models. It is installed on the inside of the service door and allows outside ventilation air, up to 25% of the total airflow rating of the unit, to be introduced through the air inlet openings and to be mixed with the conditioned air. The damper opens during blower operation and closes when the blower is off. Adjustable blade stops allow different amounts of outside air to be introduced into the building and can be easily locked closed if required.

NOTE: The above vent systems are intake only without built-in exhaust capability. Building will likely require separate field installed barometric relief or mechanical exhaust elsewhere within the conditioned space. Balancing dampers in the return air grille may be required to achieve specified amount of outdoor air intake.

BLANK OFF PLATE — BOP-1A

OPTIONAL

A blank off plate is installed on the inside of the service door. It covers the air inlet openings, which restricts any outside air from entering the unit. The blank off plate should be utilized in applications where outside air is not required to be mixed with the conditioned air.

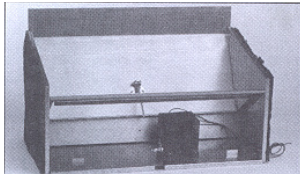

Commercial Room Ventilator

COMMERCIAL ROOM VENTILATOR — CRVS-1A

OPTIONAL

The built-in commercial room ventilator is internally mounted behind the service door and allows outside ventilation air, up to 50% of the total airflow rating of the unit, to be introduced through the air inlet openings.

The commercial room ventilator (CRV) is a simple and innovative approach to improving the indoor air quality by providing fresh air intake and exhaust capability through the CRV. The damper can be easily adjusted to control the amount of fresh air supplied into the building. The CRV can be controlled by indoor blower operation or field controlled based on room occupancy. Two versions available (except on 1.5 and 2-Ton models). The CRV and CRVS are power open - spring return on power loss, and CRVP is power open and power close. Complies with ANSI/ASHRAE Standard 62.1 "Ventilation for Acceptable Indoor Air Quality".

ECONOMIZER — JIFM-1A

OPTIONAL

The built-in economizer system is internally mounted behind the service door and allows outdoor air to be introduced through the air inlet openings. The amount of outdoor air varies in response to the system controls and settings defined by the end user. It includes a built-in exhaust air damper. The economizer is designed to provide "free cooling" when outside air conditions are cool and dry enough to satisfy cooling requirements without running the compressor. This in turn provides lower operating costs, while extending the life of the compressor.

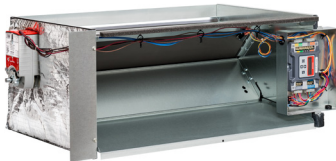

Economizer

Standard Features:

- Fully modulating
- Honeywell Direct Drive Hi-Torque Actuator
- No linkage required
- Simple single blade design
- Positive shut-off with non-stick gaskets
- Electronic Enthalpy sensor
- Honeywell JADE electronic economizer module with precision settings and diagnostics
- Moisture Eliminator and Prefilter – permanent, washable, aluminum construction

CRVS-1A TOTAL AND VENTILATION AIRFLOW

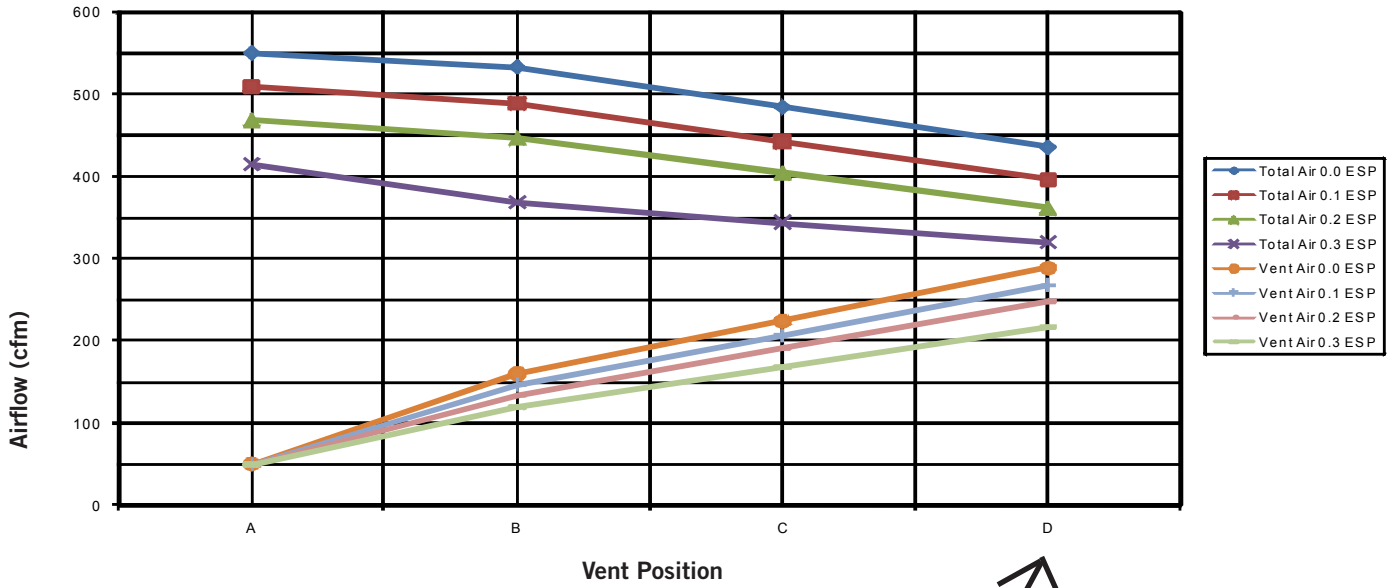

Brown/white wire must be switched from terminal X to terminal D on damper motor to attain "D" position. This will bypass potentiometer function and go to "full open" when energized.

Dimensions of Basic Unit for Architectural and Installation Requirements (Nominal)

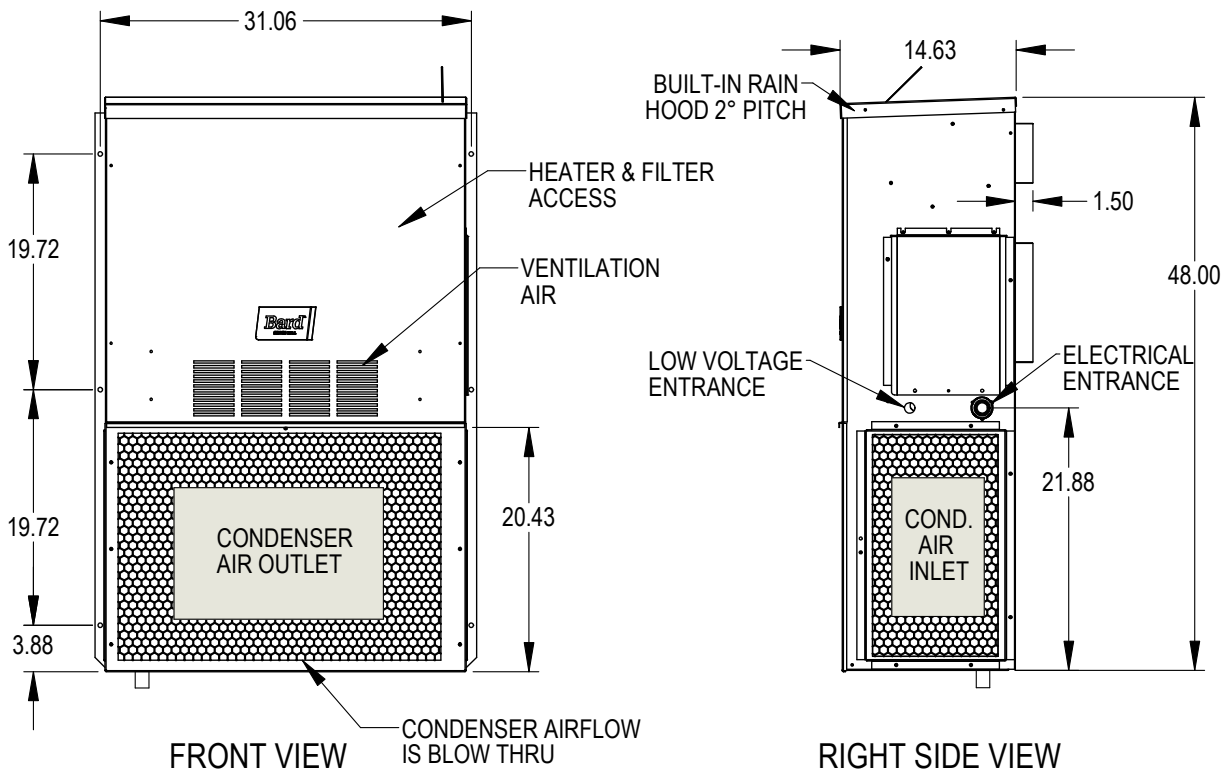
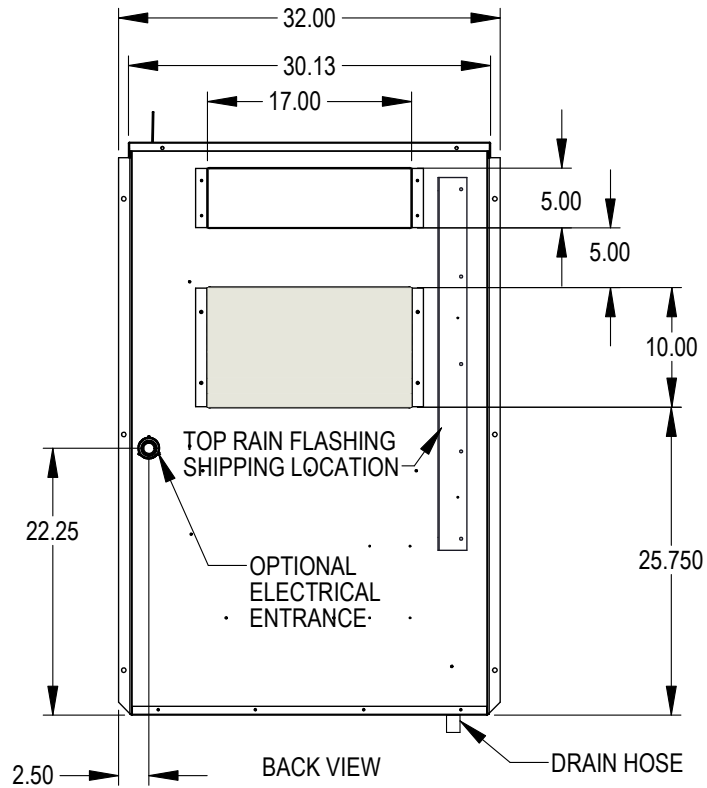

MIS-3599

Air Conditioning Model Nomenclature

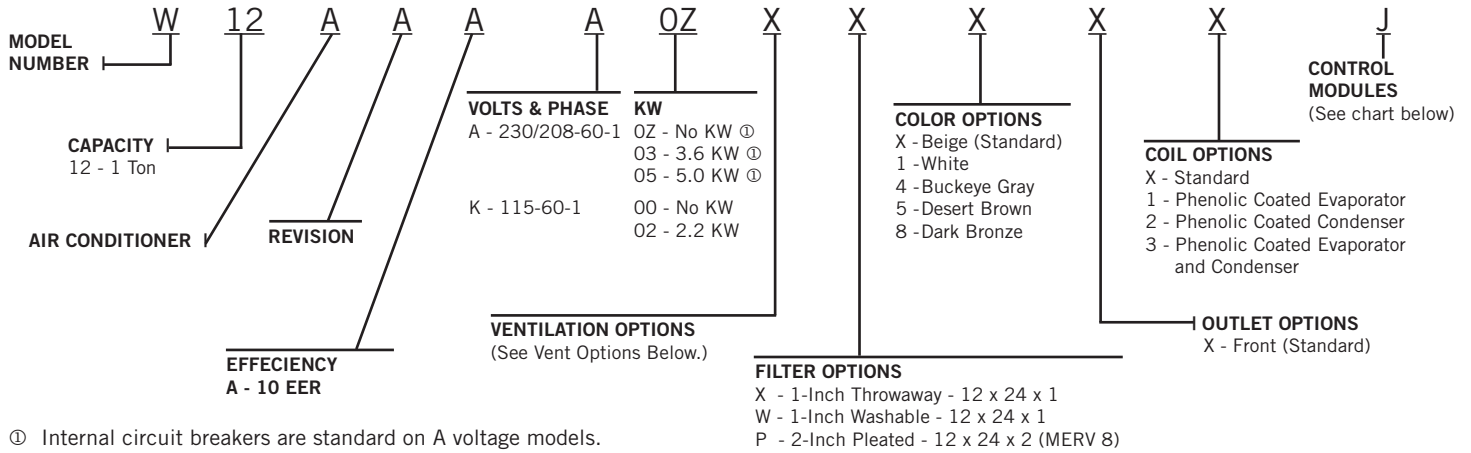

Clearances Required for Service Access and Adequate Condenser Inlet Airflow

MODEL	LEFT SIDE	RIGHT SIDE
W12AAA	15"	20"

NOTE: For side by side installation of two (2) W12AAA models there must be 20" between units.

Minimum Clearances Required to Combustible Materials

MODEL	SUPPLY AIR DUCT FIRST THREE FEET	CABINET
W12AAA	0"	0"

Ventilation Options

Model	W12AAA	
	Factory Installed Code No.	Field Installed Part No.
Barometric Fresh Air Damper - Standard	X	BFAD-1
Blank-Off Plate	B	BOP-1A
Commercial Ventilator - Spring Return w/Exhaust	V	CRVS-1A
Economizer - Fully Modulating ①	E	JIFM-1A

① Low ambient control is required with economizer for low temperature compressor operation.

Air Conditioning Control Modules

All Models Except As Noted					Factory Installed Code	Field Installed Part
HPC ①	LPC ②	CCM ③	LAC ④	ALR ⑤		
STD	STD	STD			X	N/A
STD	STD	STD	•		E	CMA-28
STD	STD	STD	•	•	J	Factory Only

STD = Standard equipment for these specified models.

① HPC High pressure control is auto reset. Always used with compressor control module (CCM) which is included. See note ③.

② LPC Low pressure control is auto reset. Always used with compressor control module (CCM) which is included. See note ③.

③ CCM Compressor control module has adjustable 30-second to 5-minute delay-on-break timer. On initial power-up, or any time the power is interrupted, the delay-on-make will be 2 minutes plus 10% of the delay-on-break setting. There is no delay-on-make during routine operation of the unit. The module also provides the lockout feature (with 1 retry) for high and/or low-pressure controls, and a 2-minute timed bypass for low-pressure control.

④ LAC Low ambient control permits cooling operation down to 0°F.

⑤ ALR The alarm relay has a set of normally open and normally closed dry contacts to provide the ability to signal a condition of shutdown on either high or low pressure controls.



Bard Manufacturing Company, Inc.
Bryan, Ohio 43506
www.bardhvac.com

Due to our continuous product improvement policy, all specifications subject to change without notice.

Before purchasing this appliance, read important energy cost and efficiency information available from your retailer.

**Form No.
S3485
March, 2016**

Supersedes: S3485-614