

USE COPPER CONDUCTORS
ONLY SUITABLE FOR AT
LEAST 75° C

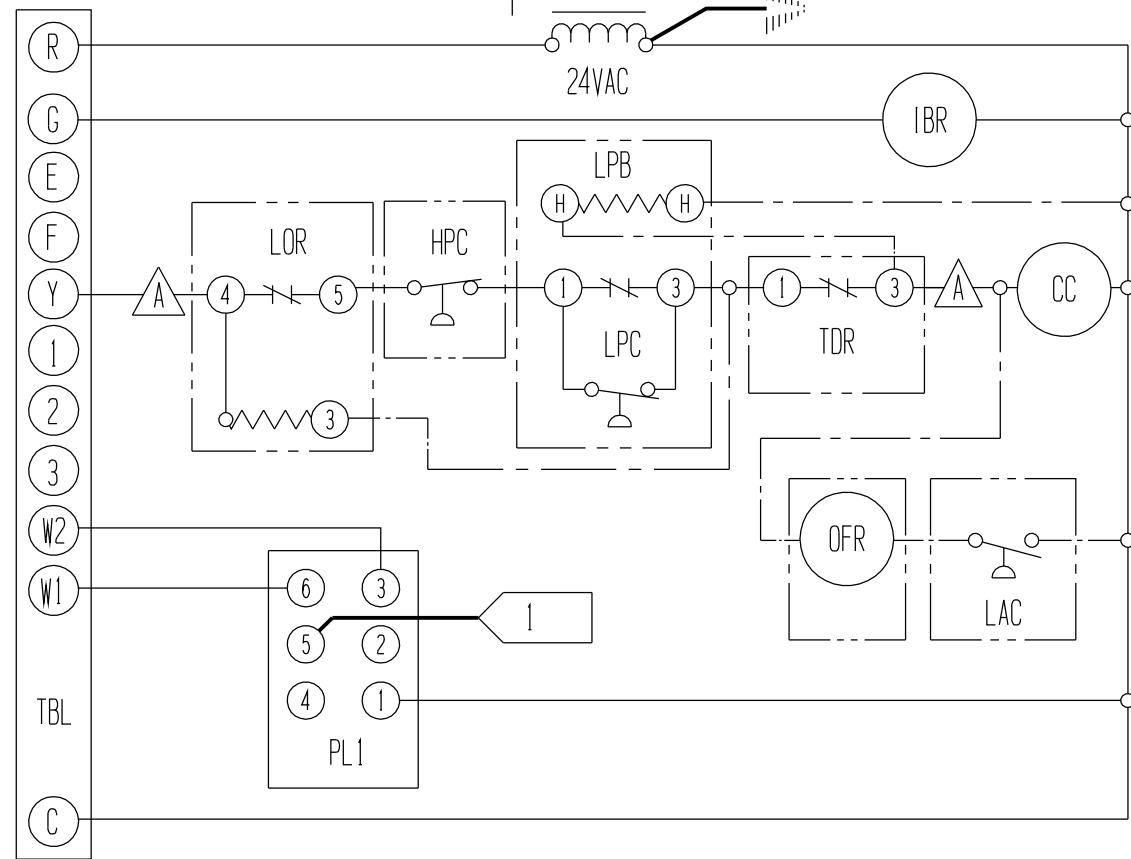
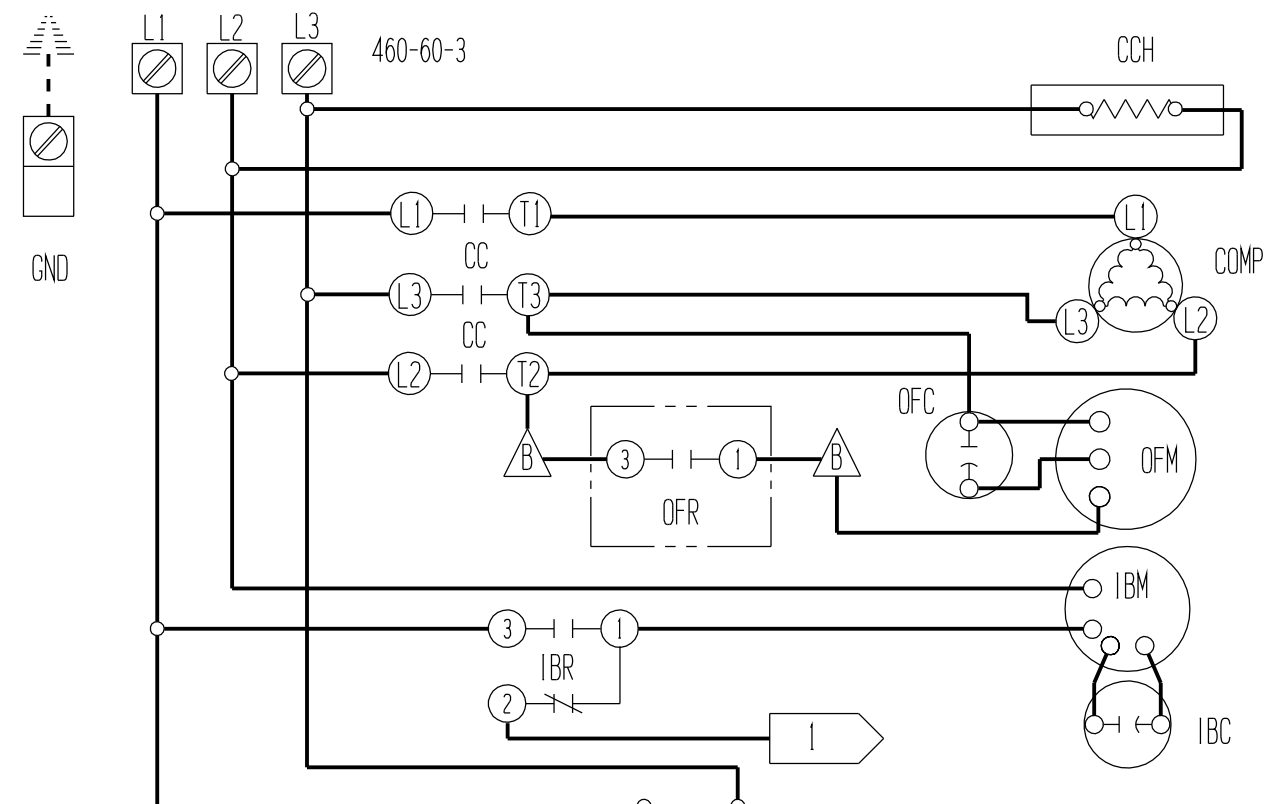

COMPONENT CODE			
CC	COMPRESSOR CONTACTOR	LPB	LOW PRESSURE BYPASS
CCH	COMPRESSOR CRANKCASE HEATER	LPC	LOW PRESSURE CONTROL
COMP	COMPRESSOR	LS	LIMIT SWITCH
GND	EQUIPMENT GROUND	OFC	OUTDOOR FAN CAPACITOR
H1	HEAT STRIP #1	OFM	OUTDOOR FAN MOTOR
H2	HEAT STRIP #2	OFR	OUTDOOR FAN RELAY
HC1	HEATER CONTACTOR #1	PD	PULL DISCONNECT
HC2	HEATER CONTACTOR #2	PL1	PLUG #1
HPC	HIGH PRESSURE CONTROL	T	TRANSFORMER
IBC	INDOOR BLOWER CAPACITOR	TB	TERMINAL BLOCK
IBM	INDOOR BLOWER MOTOR	TBL	LOW VOLTAGE TERMINAL BLOCK
IBR	INDOOR BLOWER RELAY	TCO	THERMAL CUTOFF
LAC	LOW AMBIENT CONTROL	TDR	TIME DELAY RELAY
LOR	LOCK OUT RELAY		

A , B E LABELED WIRES CONNECT IF NO OPTIONS USED.
 A FOR LOW SPEED CONNECT BLACK AND ORANGE WIRES TOGETHER AND INSULATE. CONNECT RED WIRE TO TERMINAL 1 OF IBR

	FACTORY STD.			FIELD			OPTIONAL			COLOR CODE														
	—	---	----	—	---	----	—	---	----	BK	BR	R	O	Y	G	BL	W	V (PR)	GY (S)	T	PK	L	TAN PINK LAVENDER	
HIGH VOLTAGE	—	---	----	—	---	----	—	---	----	BK	BR	R	O	Y	G	BL	W	V (PR)	GY (S)	T	PK	L	TAN PINK LAVENDER	
LOW VOLTAGE	—	---	----	—	---	----	—	---	----															
ACCESSORY	—	---	----	—	---	----	—	---	----															

BARD MFG. CO.

4095-310 C