

INSTALLATION INSTRUCTIONS

**BC48A and BC60A
INDOOR BLOWER COIL UNIT**

**FOR USE WITH
SPLIT HEAT PUMP AND
SPLIT AIR CONDITIONER SYSTEMS**

**COPYRIGHT APRIL, 1989
BARD MANUFACTURING COMPANY
BRYAN, OHIO**

BC48A and BC60A SERIES

- Built-In Electric Heating 5-30Kw (230V)
- Direct Drive Multispeed Motor (230V)
- Slide-In Return Air Filter
- Upflow - Downflow - Horizontal

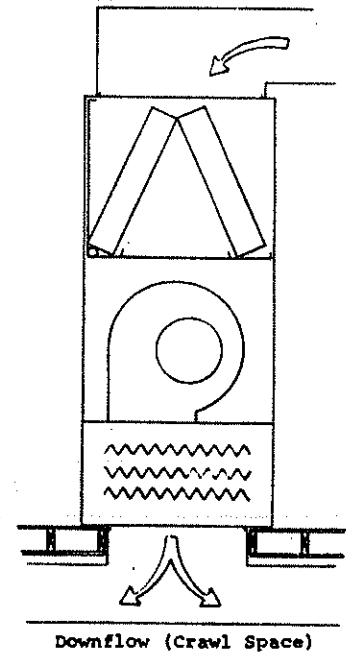
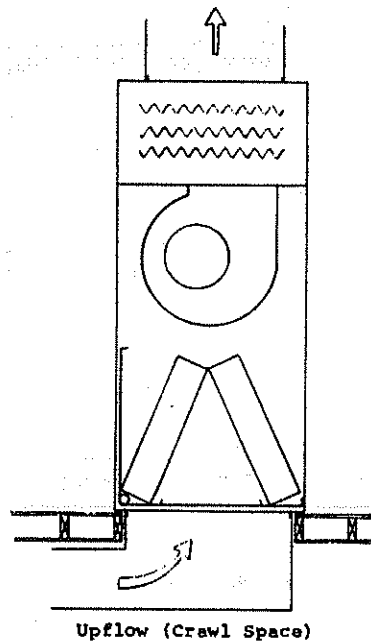
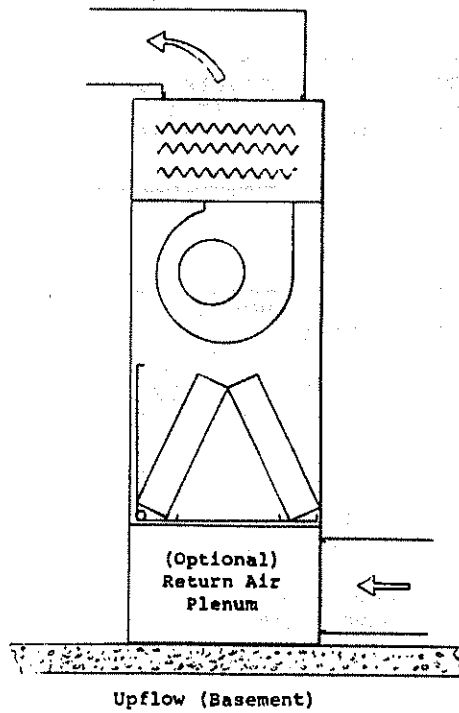
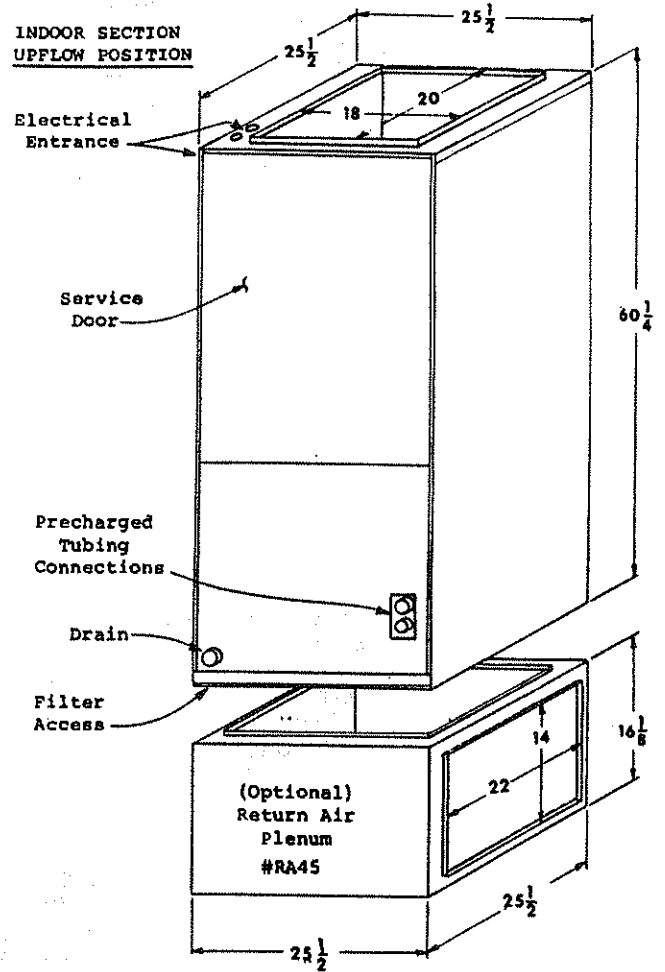
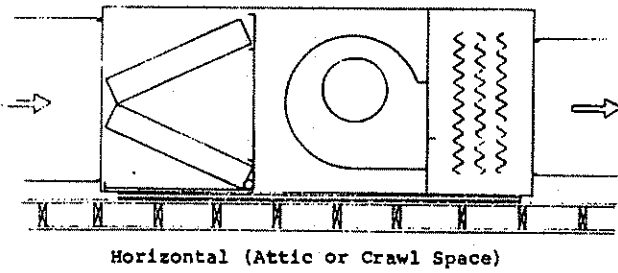

AIRFLOW PERFORMANCE DATA

MAXIMUM E.S.P. INFORMATION*						
Type of Application	Rating of Electric Heaters		MODEL BC48A		MODEL BC60A	
			High	Low	High	Low
Heat Pump Alone or Heat Pump In Conjunction With Electric Heat	30	1 Ph	--	--	--	--
	25	1 Ph	--	--	--	--
	20	1 Ph	.6	.5		
	15	1 Ph	.6	.5	.6	.5
	10	1 Ph	.6	.5	.6	.5
	30	3 Ph	--	--	--	--
	27	3 Ph	--	--	--	--
	24	3 Ph	--	--	--	--
	21	3 Ph	--	--	--	--
	18	3 Ph	.6	.5	--	--
	15	3 Ph	.6	.5	.6	.5
	12	3 Ph	.6	.5	.6	.5
	9	3 Ph	.6	.5	.6	.5
	Heat Pump In Emergency Heat Mode (Electric Heat Only Or Air Cond	30	1 Ph	.6	.5	.6
25		1 Ph	.6	.5	.6	.5
20		1 Ph	.6	.5	.6	.5
15		1 Ph	.6	.5	.6	.5
10		1 Ph	.6	.5	.6	.5
30		3 Ph	.6	.5	.6	.5
27		3 Ph	.6	.5	.6	.5
24		3 Ph	.6	.5	.6	.5
21		3 Ph	.6	.5	.6	.5
18		3 Ph	.6	.5	.6	.5
15		3 Ph	.6	.5	.6	.5
12		3 Ph	.6	.5	.6	.5
9		3 Ph	.6	.5	.6	.5

*Values shown are for standard bottom return opening mounted in the vertical position. Reduce the E.S.P. shown by .10 with #RA45 return air plenum installed. Reduce the E.S.P. shown by .05 for horizontal and counterflow installations.

BLOWER COIL PERFORMANCE				
CFM DRY COIL WITH FILTER				
E.S.P. Inches H ₂ O 	BC48A		BC60A	
	High	Low	High	Low
.00	2040	1825	2050	1830
.10	1965	1775	2010	1810
.20	1885	1725	1950	1785
.30	1810	1670	1875	1715
.40	1715	1585	1800	1660
.50	1615	1500	1715	1590
.60	1520	1420	1620	--

MAXIMUM ALLOWABLE AIRFLOW RANGE

RATED CFM

BC48A 1500 to 1885 CFM

1650

BC60A 1590 to 1950 CFM

 E.S.P. available for duct system.

Model	Volts/PH	Heater Kw @ 240V	Max. Unit Amps	Heater Amps	Internal Fuses		Required over- Δ current protection		Minimum Ckt. Ampacity		Power Ckt. Wiring Δ		Ground Wire Size Δ			
					Ckt. A	Ckt. B	Ckt. A	Ckt. B	Ckt. A	Ckt. B	Ckt. A	Ckt. B	Ckt. A	Ckt. B	Ckt. A	Ckt. B
BC48A	240/1	0	4.4				15		15		14		14			
		10	46	41.6			60		58		4		10			
		15	66.9	62.5	60/30		90		84		2		8			
		20 Δ	87.6	83.2	60/60		110		110		2		6			
		25	108.6	104.2	60	60/30	60	80	58	78	4	3	10	8		
		30	129.4	125.0	60	60/60	60	110	58	104	4	2	10	6		
	240/3	0	4.4					15		15		14		14		
		9	26.1	21.7				35		33		8		10		
		12	33.3	28.9				45		42		6		10		
		15	40.5	36.1				60		51		6		10		
		18 Δ	47.6	43.2				60		60		4		10		
		21	54.9	50.5	35/40		70		69		4		8			
		24	62.2	57.8	45/40		80		78		3		8			
		27	69.4	65.0	45/45		90		87		2		8			
30	76.6	72.2	60/45		100		96		1		8					
BC60A	240/1	0	4.4				15		15		14		14			
		10	46	41.6			60		58		4		10			
		15 Δ	66.9	62.5	60/30		90		84		2		8			
		20	87.6	83.2	60/60		110		110		2		6			
		25	108.6	104.2	60	60/30	60	80	58	78	4	3	10	8		
		30	129.4	125.0	60	60/60	60	110	58	104	4	2	10	6		
	240/3	0	4.4					15		15		14		14		
		9	26.1	21.7				35		33		8		10		
		12	33.3	28.9				45		42		6		10		
		15 Δ	40.5	36.1				60		51		6		10		
		18	47.6	43.2				60		60		4		10		
		21	54.9	50.5	35/40		70		69		4		8			
		24	62.2	57.8	45/40		80		78		3		8			
		27	69.4	65.0	45/45		90		87		2		8			
30	76.6	72.2	60/45		100		96		1		8					

Δ Suggested size based on use of 60°C wiring material for ampacities less than 100A and 75°C wiring material for ampacities greater than 100A.

Δ Based upon Table 250-95 °F 1981 N.E.C.

Δ Maximum of 20Kw 1 phase and 18Kw 3 phase operates in conjunction with heat pump. Any installed Kw above these amounts operates during emergency heat operation. See page 6 for additional information.

Δ Time delay fuses or "HACR Type" circuit breakers must be used for 60 and smaller sizes. Standard fuses or circuit breakers are suitable for sizes 70 and larger.

Δ Maximum of 15Kw, 1 phase and 3 phase, operates in conjunction with heat pump. Any installed Kw above this amount operates during emergency heat operation.

GENERAL

Units are shipped completely assembled and internally wired, requiring only duct connections, thermostat wiring and external 208-240 volt AC power supply.

The BC48A and BC60A blower coil units, with various Kw electric heat options are suitable for use with the following air conditioner and heat pump outdoor sections. It can be used both as an air conditioning system with electric heat and as a heat pump with electric heat. Refer to sections titled, "AIR CONDITIONING WITH ELECTRIC HEAT and HEAT PUMP WITH ELECTRIC HEAT" for complete information.

APPROVED COMBINATIONS

Air Conditioning		Heat Pump	
Outdoor Section	Indoor Section	Outdoor Section	Indoor Section
42ECQ1	BC48A	42HPQ4	BC48A
48ECQ2	BC48A	48HPQ5	BC48A
60ECQ1	BC60A	60HPQ5	BC60A
60ECQ1	BC48A	48HPQ5	BC60A
42,48,60UAC	BC48A		
42,48,60UAC	BC60A		

UNPACKING

Upon receipt of equipment, carton should be checked for external signs of damage. If damage is found, request for inspection by carrier's agent should be made in writing immediately.

SIZING

Size of unit for a proposed installation should be based on heat loss of calculation made according to methods of National Warm Air Heating and Air Conditioning Association. The air duct should be installed in accordance with the Standards of the National Fire Protection Association for the Installation of Air Conditioning and Ventilating Systems of Other Than Residence Type, NFPA No. 90A, and Residence Type Warm Air Heating and Air Conditioning Systems, NFPA No. 90B. Where local regulations are at a variance with instructions, installer should adhere to local codes.

MOUNTING POSITIONS

The BC48A and BC60A can be installed in three positions with respect to airflow direction: Upflow, horizontal and downflow. The general intent of these mounting positions is shown on the cover page of this installation manual. Capacity and efficiency ratings are certified in the vertical installation position. Capacity may be reduced slightly for other installation positions.

Return air plenum RA45 is required for upflow installations (unless a crawl space or similar installation with return air duct beneath unit mounting surface). The RA45 plenum is square in design and the 14" x 22" duct flange can be positioned as desired for ease of installation.

The unit is shipped with the coil installed for upflow mounting position. It is secured in place by four screws, one at each bottom front corner of the slide support angles and one on the front and rear of the top left slide support. To convert to either horizontal or downflow position, remove front access panel, remove four screws securing coil pan assembly and remove coil.

Place cabinet in desired mounting position, and reinstall coil as shown on cover page. Make sure the coil is installed as shown with respect to blower. It is not necessary to reinstall shipping bracket or the two securing screws through the slide angles.

IMPORTANT: The unit as received has coil installed for upflow position only. It must be rotated 180° for both horizontal and downflow positions. See Note under "Condensate Drain."

DUCTWORK

Design the ductwork according to methods given by the National Warm Air Heating and Air Conditioning Association. When duct runs through unheated spaces, it should be insulated with a minimum of two inches of insulation. Use insulation with a vapor barrier on the outside of the insulation. Flexible joints should be used to connect the ductwork to the equipment in order to keep the noise transmission to a minimum.

FILTER

These units come equipped with a 24" x 24" x 1" thick disposable fiberglass filter and must not be operated without a filter in place. Filter access is gained by removing an angle piece located at the bottom of the main unit cabinet (as viewed in upflow position) just above the RA45 plenum location - if utilized.

The filter should be replaced periodically throughout the year, as these are year-round heat-cool systems. Special attention should be given to filter cleanliness on any new installation, as airborne dust and debris from recent construction can easily plug a filter in a matter of days.

Dirty filters are the most prevalent and most easily corrected problem to be encountered in any forced air heating and/or cooling system.

LOCATION AND CLEARANCES

All access to the equipment is from one side, and at least 24 inches should be provided from this side for service access.

Unit casing is suitable for 0 inch clearance. The first four (4) feet of ductwork attached to the outlet (supply air) connections of the unit are to have a minimum of one inch clearance, with 0 inch clearance for any remaining ductwork.

CONDENSATE DRAIN

Determine where the drain line will run. This drain line contains cold water and must be insulated to avoid drops of water from dropping on ceiling, etc. A trap must be installed in the primary drain line below the bottom of the drain pan.

For horizontal installations with auxiliary drain pan, a separate drain line should be run from the auxiliary drain pan and terminated where the homeowner can see it. Be certain to show the homeowner the location of the drain line and to explain its purpose. In the event of overflow of primary drain, water will collect in auxiliary pan and run out through the auxiliary drain line.

It is not recommended that any condensate drain lines be connected to a sewer main. Drain lines must be installed in accordance with local codes.

When installed horizontal in an attic installation, a platform should be made for the unit to sit on. This platform can be made from 3/4 inch plywood or boards. An auxiliary drain pan should always be used when equipment is installed over a finished living area, to provide protection from water damage in case of plugging of the primary drain line from the unit condensate collection pan.

Secure four pieces of cork or live rubber, 4" x 4", of sufficient thickness to allow primary drain to clear edge of auxiliary drain pan, under each corner of the unit.

NOTE: There is a 3/8" copper tube brazed on an angle through the coil drain pan approximately 2 inches from the 3/4 inch main drain pipe coupling. This is an overflow drain to control the point at which water would exit the drain pan in the event the primary drain becomes plugged. When the coil assembly is removed and reinstalled for downflow, make sure the 3/8 inch drain overflow tube extends slightly beyond the coil door when in place.

INTERCONNECTING TUBING

It is recommended that the interconnecting tubing be the CT-12 series charged tubing sets. This is a precharged tubing set with an insulated suction line. Both suction and liquid line are equipped with the correct quick connect fittings for proper match-up to the indoor and outdoor sections. The CT-12 series is available in standard tubing lengths of 15, 25, 35 and 45 feet.

NOTE: Applicable installation codes may limit installation to single story structure only if return air duct is not used.

THERMOSTAT LOW-VOLTAGE WIRING

A 24V terminal block is mounted on the inside of the unit. There is also a 24V terminal block located in the outdoor section of remote heat pumps and two tagged 24V wires in the outdoor section of remote air conditioners.

Specific control circuit wiring diagrams for the various applications are referenced in the sections titled "AIR CONDITIONING WITH ELECTRIC HEAT and HEAT PUMP WITH ELECTRIC HEAT." These diagrams detail the recommended controls and wiring to allow the best possible operation of the different types of systems with respect to energy conservation while still maintaining close comfort levels for the occupant.

TRANSFORMER, HEAT-COOL BLOWER RELAY, TIME DELAY RELAY (OPTIONAL), FUSING

The BC48A and BC60A are provided with a 65VA transformer. The transformer is protected by a 3 Amp fuse located in the 24V terminal block compartment and wired into the transformer secondary.

A heat-cool blower relay is installed to provide blower operation automatically with any thermostat demand for heating or cooling, or can be operated continuously for air circulation on command from the thermostat fan switch.

An optional time delay relay may be installed in the cooling low voltage circuit. This relay permits the blower motor to continue to operate for approximately one minute following each cooling cycle.

All single phase models with 15Kw or higher and all three phase models with 18Kw or higher are internally fused and sub-divided. See electrical data tables for more information.

UNIT OPERATION

The controls in the BC48A and BC60A provide for manual/auto blower operation in addition to the staging of the installed electric heat. The table below lists the stages by Kw breakdown for both air conditioning and heat pump installations.

IMPORTANT NOTE: With model BC48A a maximum of 20Kw, 1 phase and 18Kw, 3 phase can be operated in conjunction with a heat pump. If using model BC60A, the maximum amount of electric heat, single and three phase to be used in conjunction with a heat pump is 15Kw. Larger Kw's can be installed as shown below, but will function only during defrost cycle, emergency heat operation, or periods of compressor cut-off, if used.

TWO SPEED BLOWER MOTOR

The BC48A and BC60A both have a two speed, 1/2 hp blower motor.

Motor lead wire identification is as follows:

- Common - Yellow
- High - Black
- Low - Red
- Capacitor - Brown (2)

Both models are shipped wired on high speed. The unused red (low speed) lead wire is taped off. If low speed operation is desired, remove and tape black wire from terminal 6 on blower relay and connect red wire to terminal 6. Refer to wiring diagrams for electrical circuitry and to airflow charts for capabilities and limitations on blower speeds, static pressures and air delivery versus installed Kw heaters.

BLOWER MOTOR OILERS

The blower motors should be oiled twice a year with approximately 8-10 drops of 20 weight motor oil. DO NOT over-oil and DO NOT use 3-in-1 oil or any other light oil.

IMPORTANT NOTE FOR DOWNFLOW INSTALLATION: Loosen belly-band bolt securing motor enough to rotate motor so oilers are above either 3 or 9 o'clock position so oilers do not drain and to permit reoiling.

CONTROL STAGES BY HEATER KW									
Model	Total Kw	PH	Matched with A/C			Matched with Heat Pump			
			Wall Stat		O. D. Stat	Wall Stat		O. D. Stat	Em.Heat
			1st Stage	2nd Stage		1st Stage	2nd Stage		
BC48A	10	1	10	--		H.P. ①	10 ⑤		
	15	1	10	5		H.P.	15 ⑤ ⑧	⑧	
	20	1	10	10		H.P.	20 ③ ⑤ ⑧	③ ⑧	
	25	1	10	10	5 ②	H.P.	20 ③ ⑤ ⑧	③ ⑧	5
	30	1	10	10	10 ②	H.P.	20 ③ ⑤	③	10
	9	3	9	--		H.P.	9 ⑤		
	12	3	12	--		H.P.	12 ⑤		
	15	3	15	--		H.P.	15 ⑤		
	18	3	9	9		H.P.	9 ④		9
	21	3	9	12		H.P.	9 ④		12
	24	3	12	12		H.P.	12 ④		12
	27	3	12	15		H.P.	12 ④		15
	30	3	15	15		H.P.	15 ④		15
	BC60A	10	1	10	--		H.P. ①	10 ⑤	
15		1	10	5		H.P.	15 ⑤ ⑧	⑧	
20		1	10	10		H.P.	15 ⑤ ⑧	⑧	
25		1	10	10		H.P.	15 ⑤ ⑧	⑧	
30		1	10	10		H.P.	15 ⑤	⑧	
9		3	9	--		H.P.	9 ⑤		
12		3	12	--		H.P.	12 ⑤		
15		3	15	--		H.P.	15 ⑤		
18		3	9	9		H.P.	9 ④		9
21		3	9	12		H.P.	9 ④		12
24		3	12	12		H.P.	12 ④		12
27		3	12	15		H.P.	12 ④		15
30		3	15	15		H.P.	15 ④		15

- ① Heat Pump is always 1st stage.
- ② If O.D. stat is not used, 24V terminals DH and OI must be connected together. The Kw shown under O.D. stat will then cycle with 2nd stage.
- ③ If one O.D. stat is used, 10Kw will switch from 2nd stage to O.D. stat, leaving only 10Kw on 2nd stage. This is normally recommended.
- ④ This amount of heat also cycles on during brief defrost cycles.
- ⑤ If 2nd stage wall stat is not calling for heat, this amount of Kw will automatically come on during defrost cycles.
- ⑥ If 2nd stage wall stat is not calling for heat, 5Kw will automatically come on during defrost.
- ⑦ To operate all 18Kw with H.P., use one O.D. stat.
- ⑧ If one O.D. stat is used, 5Kw will switch from 2nd stage to O.D. stat, leaving only 10Kw on 2nd stage.

AIR CONDITIONING WITH OR WITHOUT SUPPLEMENTAL ELECTRIC HEAT

When the BC48A or BC60A are matched with the approved outdoor air conditioning sections, different thermostats may be required depending on installed Kw and desired staging. Listed below are the "Recommended" wall thermostats, subbases, number of outdoor stats, and number of 24V wires required.

Model	KW	PH	Part No.	Description	Part No.	Description	No. of Outdoor Thermostats ①	No. of 24V Wires Required	
								Stat to I.D. Unit	I.D. Unit to O.D. Unit
BC48A	0	1	8403-002	T87F3111	8404-003	Q539A1220		3	2
	10	1	"	"	"	"		4	2
	15	1	8403-019	T874C1000	8404-012	Q674A1001		5	2
	20	1	"	"	"	"		5	2
	25	1	"	"	"	"	1	5	2
	30	1	"	"	"	"	1	5	4
	0	3	8403-002	T87F3111	8404-003	Q539A1220		3	2
	9	3	"	"	"	"		4	2
	12	3	"	"	"	"		4	2
	15	3	"	"	"	"		4	2
	18	3	8403-019	T874C1000	8404-012	Q674A1001		5	2
	21	3	"	"	"	"		5	2
	24	3	"	"	"	"		5	2
	27	3	"	"	"	"		5	2
30	3	"	"	"	"		5	2	
BC60A	0	1	8403-002	T87F3111	8404-003	Q539A1220		3	2
	10	1	"	"	"	"		4	2
	15	1	8403-019	T874C1000	8404-012	Q674A1001		5	2
	20	1	"	"	"	"		5	4
	25	1	"	"	"	"	1	5	4
	30	1	"	"	"	"	1	5	4
	0	3	8403-002	T87F3111	8404-003	Q539A1220		3	2
	9	3	"	"	"	"		4	2
	12	3	"	"	"	"		4	2
	15	3	"	"	"	"		4	2
	18	3	8403-019	T874C1000	8404-012	Q674A1001		5	2
	21	3	"	"	"	"		5	2
	24	3	"	"	"	"		5	2
	27	3	"	"	"	"		5	2
30	3	"	"	"	"		5	2	

① ODT-070 adjustable range 0 to 70°F. These are field installed in outdoor sections.

HEAT PUMP WITH SUPPLEMENTAL ELECTRIC HEAT

The system and its safety controls are designed in such a manner that the heat pump and a maximum of 20Kw, 1 phase and 18Kw, 3 phase (15Kw, 1 and 3 phase for model BC60A) can operate simultaneously. Larger Kw's can be installed, however, and are controlled by the emergency heat switch and/or field installed compressor cut-off. This allows for "total" heating capability in case of a malfunction in the outdoor heat pump unit.

Listed below are the thermostats required for use with these heat pump models. It is essential that one or the other of these thermostat and subbase combinations be used because the internal wiring of both the heat pump unit and the thermostat are specifically designed for one another.

Model	KW	PH	Thermostat & Subbase Combination	No. of ① Outdoor Thermostats ②	No. of 24V Wires Required	
					Stat to I.D. Unit	I.D. Unit to O.D. Unit
BC48A	0	1	A or B		8	6
	10	1	"	③	9	7
	15	1	See Chart	③	10	9
	20	1	Next Page	1 ④	10	9
	25	1	"	1 ③	10	9
	30	1	"	1 ③	10	9
	0	3	A or B		8	6
	9	3	"		9	7
	12	3	See Chart		9	7
	15	3	Next Page	③	9	7
	18	3	"		10	9
	21	3	"		9	7
	24	3	"		9	7
	27	3	"		9	7
30	3	"		9	7	
BC60A	0	1	A or B		8	6
	10	1	"	③	9	7
	15	1	See Chart	③	10	9
	20	1	Next Page	1 ④	10	9
	25	1	"	1 ③	10	9
	30	1	"	1 ③	9	7
	0	3	A or B		5	5
	9	3	"		9	7
	12	3	See Chart		9	7
	15	3	Next Page		9	7
	18	3	"		10	9
	21	3	"		9	7
	24	3	"		9	7
	27	3	"		9	7
30	3	"		9	7	

- ① ODT-070 adjustable range 0 to 70°F. These are field installed in outdoor section.
- ② Compressor cutoff recommended for all climate areas that experience sub-zero temperatures. Add one (1) additional ODT-070 to total if this applies.
- ③ The last 5, 10 and 9Kw for 15, 20, 25 and 18Kw models can be held off by using one (1) outdoor stat. This is optional--see CCD4260-8.
- ④ One outdoor thermostat should be used to keep 1st 20Kw from cycling together on stage 2 of wall stat. The 5, 10 or 15Kw cycles on only during emergency heat, compressor cutoff, or defrost cycle. See CCD4260-8.

WALL THERMOSTAT AND SUBBASE COMBINATIONS			
Group	Thermostat	Subbase	Predominant Feature
A	8403-017 (T874R1129)	8404-009 (Q674L1181)	Heat or Cool-No Auto ①
B	8403-019 (T874N1024)	8404-010 (Q674F1261)	Automatic Heat-Cool Changeover Position ②

- ① No automatic changeover position--must manually place in heat or cool. Reversing valve remains energized at all times system switch is in heat position (except during defrost cycle). No pressure equalization noise when thermostat is satisfied on either heating or cooling.
- ② Allows thermostat to control both heating and cooling operation when set in "auto" position. Reversing valve de-energizes at end of each "on" heating cycle.

IMPORTANT NOTICE: Both thermostat and subbase combinations shown above incorporate the following features: Man-auto fan switch, Off-Heat-Cool-Em.Ht. switch, and two (2) indicator lamps--one for Em.Ht. and one for compressor malfunction.

THERMOSTAT INDICATOR LAMPS

The red lamp marked "Em.Ht." comes on and stays on whenever the system switch is placed in the Em. Ht. position. The green lamp marked "check" will come on if there is any problem that prevents the compressor from running when it is supposed to be.

EMERGENCY HEAT POSITION

The operator of the equipment must manually place the system switch in this position. This is done when there is a known problem with the outdoor section, or when the green "check" lamp comes on indicating a problem.

COMPRESSOR MALFUNCTION RELAY

Actuation of the green "check" lamp is accomplished by a voltage type relay which is factory installed and located in the outdoor unit on 1 phase units only. The compressor malfunction relay is optional and must be field installed on all matching 3 phase outdoor units.

THERMAL CUT-OFFS AND LIMIT CONTROL

A thermal cut-off is installed for each 3, 4 or 5Kw segment of the installed electric heaters (9Kw - 3-3Kw, 15Kw - 3-5Kw, etc.). These are a back-up safety device to the primary safety--the high limit control. The thermal cut-offs are located in the heater mounting plate in the control compartment, and are a one-shot device. They must be replaced with an identical part should they function.

The high limit control is an automatic reset device and controls the operation of the electric heaters during any abnormal condition: Dirty filters, closed registers, defective blower motor, etc.

Access to the limit control is gained by removing a 6" x 8" plate, secured by four (4) screws. This plate is attached to the blower deck to the left of the blower housing (when viewing the unit in upflow position from access panel side). It is not absolutely necessary, but desirable, to remove the blower housing for easiest access.

CONTROL CIRCUIT WIRING DIAGRAMS

To aid the installer in making the 24 volt control circuit connections for all the Kw and phase variations, and also to show "Recommended" installations of outdoor thermostat and compressor cut-off options, a series of control circuit wiring diagrams are included in this manual. These diagrams depict the low voltage terminal boards located in the indoor and outdoor sections, and the respective wall thermostats and subbases necessary to accomplish the required control functions.

The table above lists, by Kw and phase, the appropriate control circuit diagram (CCD) number. The diagrams are located on pages 9 and 10 of this manual.

CONTROL CIRCUIT WIRING DIAGRAMS				
Group	Type	Total Kw	Phase	CCD No.
BC48A	A/C	0	1 or 3	CCD4260-1
		10	1	CCD4260-2
		15, 20	1	CCD4260-3
		25, 30	1	CCD4260-4
	H/P	9, 12, 15	3	CCD4260-2
		18, 21, 24, 27, 30	3	CCD4260-3
		0	1 of 3	CCD4260-6
		10	1	CCD4260-7
BC60A	A/C	15, 20, 25, 30	1	CCD4260-8
		9, 12, 15	3	CCD4260-7
		18	3	CCD4260-8
		21, 24, 27, 30	3	CCD4260-7
	H/P	0	1 or 3	CCD4260-1
		10	1	CCD4260-2
		15, 20, 25	1	CCD4260-3
		30	1	CCD4260-5
H/P	9, 12, 15	3	CCD4260-2	
	18	3	CCD4260-3	
	21, 24, 27, 30	3	CCD4260-6	
		3	CCD4260-7	

THERMOSTAT HEAT ANTICIPATION

Some of the wall thermostats require setting of the heat anticipator to assure proper cyclic operation and good temperature control within the structure being heated and cooled. Other anticipators are fixed and require no adjustment. The table below summarizes the anticipator types and their ranges, if adjustable.

Part No.	Description	Stage	Type	Range	Stage	Type
8403-002	T87F3111	1	Adj.	.10-1.2A	1	Fixed
8403-019	T874C1000	1	Adj.	.10-1.2A	1	Fixed
		2	Adj.	.10-1.2A		
8403-017	T874R1129	1	Adj.	.10-1.2A	1	Fixed
		2	Fixed	--		
8403-018	T874N1024	1	Adj.	.10-1.2A	1	Fixed
		2	Fixed	--		

- ① Both of these thermostats have a W2 and W3 connection terminal that are controlled by the 2nd stage mercury switch. W2 is connected to the fixed anticipator and W3 bypasses the anticipator, thus allowing outdoor thermostat operation without disrupting cycling rate, etc.

DOWNFLOW (COUNTERFLOW) INSTALLATION

A CFB45 combustible floor base is required for downflow installations to assure a 1" clearance from combustible materials to the outlet plenum (duct).

A $20\frac{1}{2}$ " x $22\frac{1}{2}$ " opening is required in the floor (mounting surface). See illustrations.

The CFB45 combustible floor base must be ordered separately. It is not included as part of the basic unit.

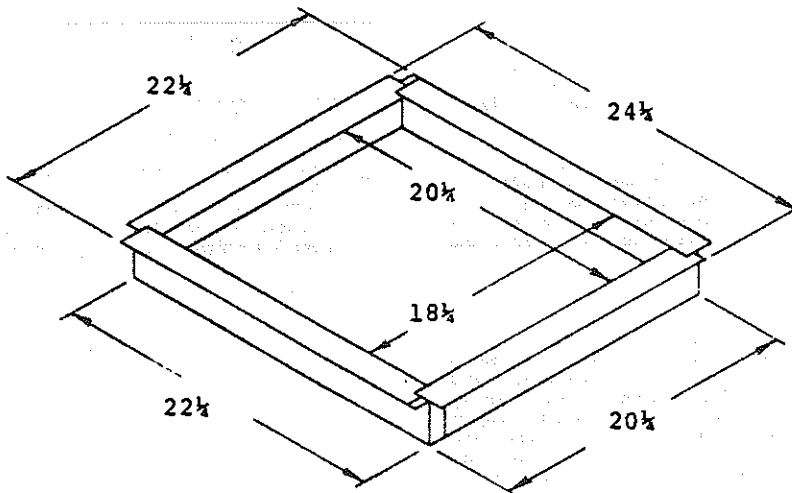
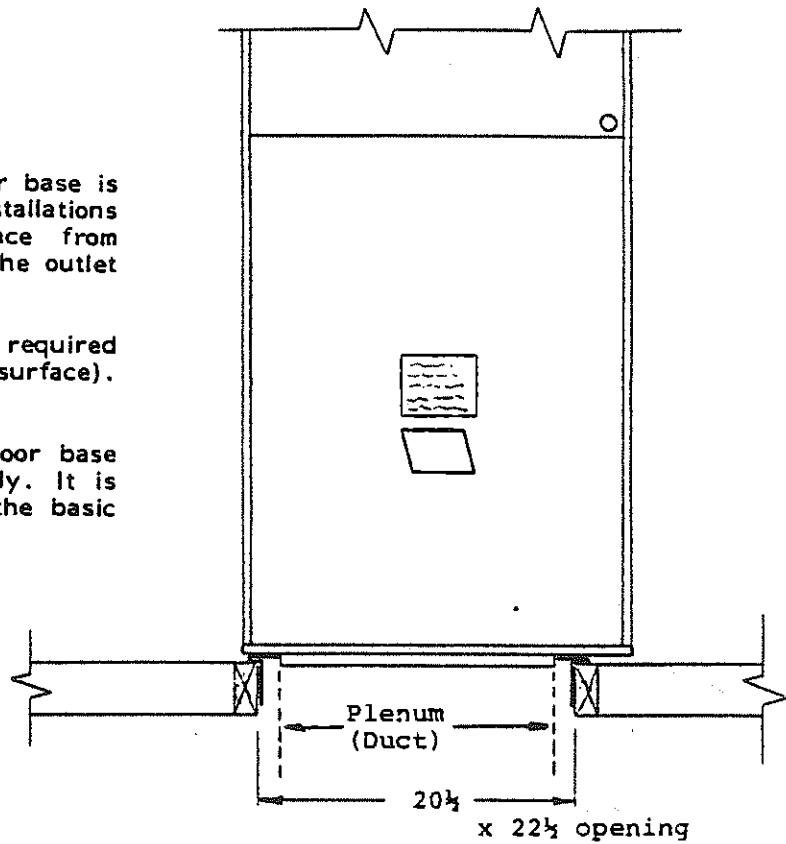

AIR CONDITIONING CONTROL CIRCUIT WIRING DIAGRAMS

CCD4260-1

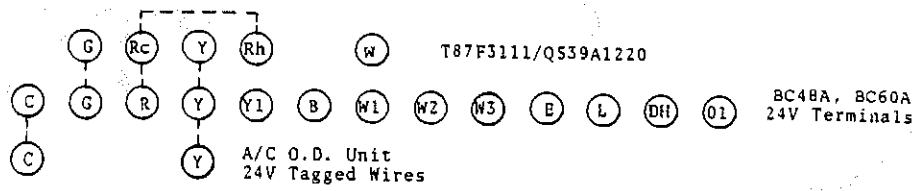

CCD4260-2

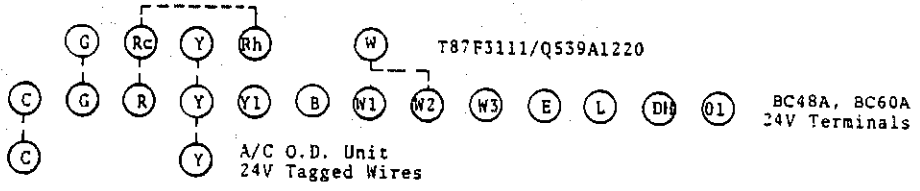

CCD4260-3

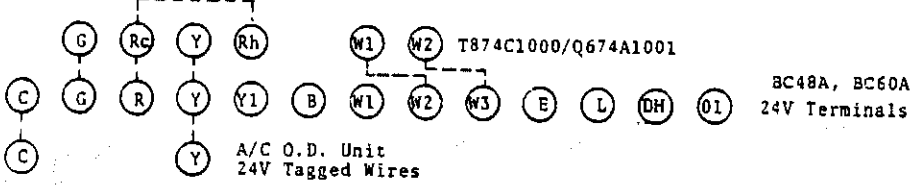

CCD4260-4

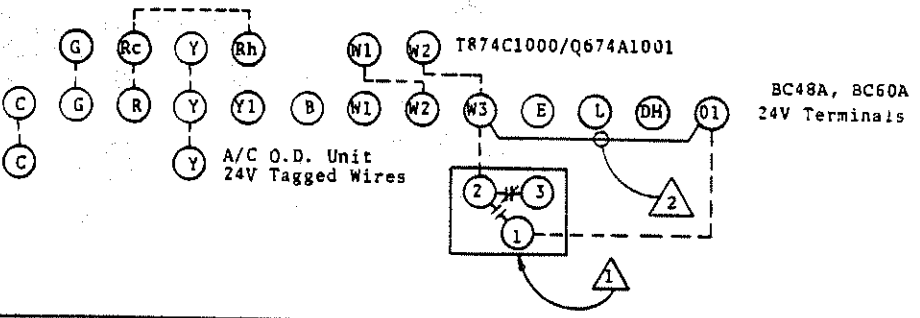

CCD4260-5

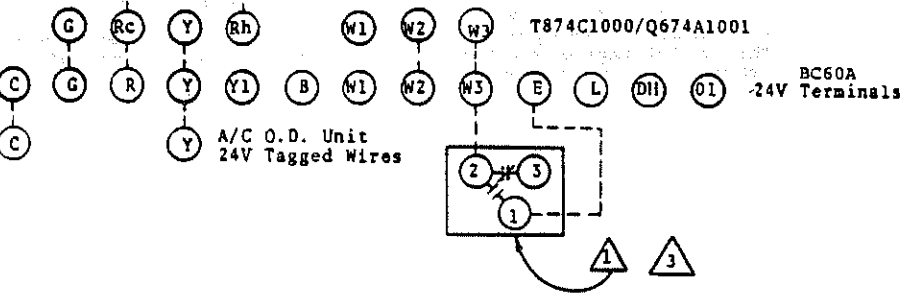

NOTES:

- ⚠ Outdoor thermostat used to hold last 5, 10 or 15Kw (for 25 and 30Kw models respectively), from cycling with the normal 10Kw on 2nd stage of wall stat.
- ⚠ Remove factory jumper W3 to O1 when outdoor thermostat is installed.
- ⚠ If an outdoor thermostat is not used, a field installed jumper is to be installed between terminals W3 and 3.

HEAT PUMP CONTROL CIRCUIT WIRING DIAGRAMS

CCD4260-6

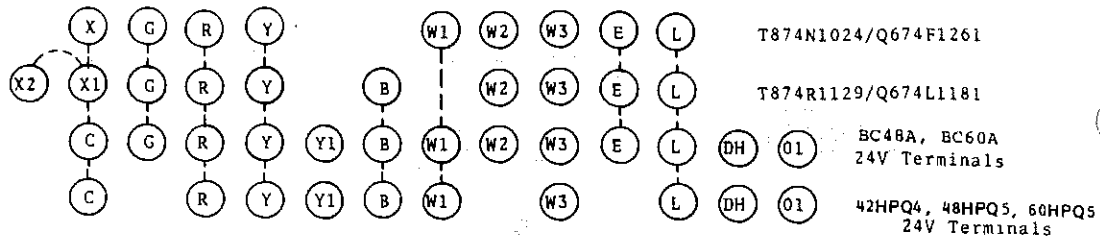

CCD4260-7

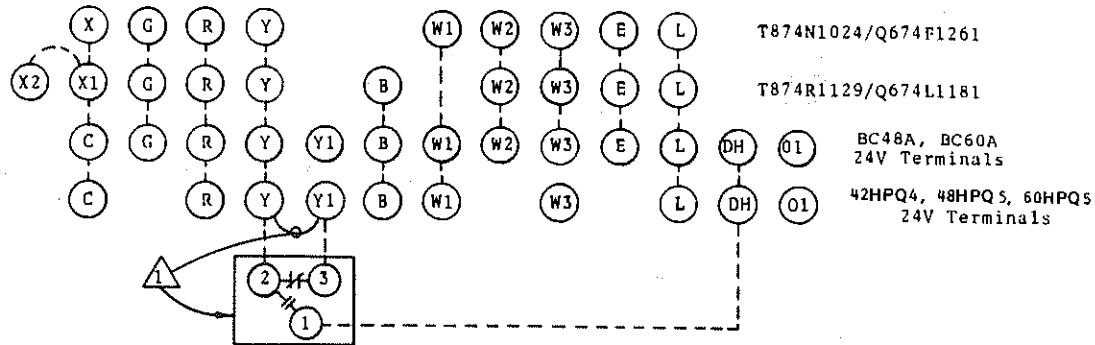

CCD4260-8

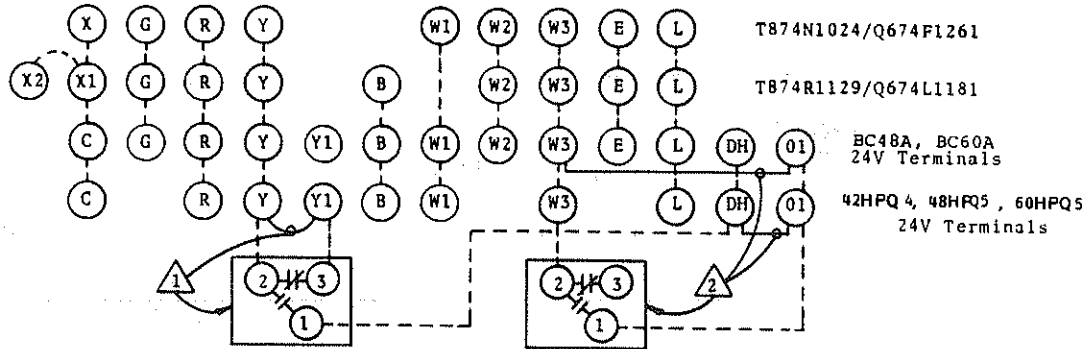

NOTES:



Optional ODT-070 compressor cutoff. Locate in outdoor unit control box. Remove jumper Y-Y1. Will automatically shut down compressor and turn on a bank of electric heat in its place. Electric heat will not operate on 1st and 2nd stages of wall stat.



Optional outdoor thermostat, used to keep last 5, 10 or 12Kw heater banks from cycling with the 1st 10 or 9Kw on 2nd stage of wall stat. Cycles "on" based on outdoor temperature. Automatically cycles on during defrost, emergency heat and compressor cut-off. Remove factory jumpers W3-01 at indoor unit and DH-01 at outdoor unit.

SPLIT SYSTEM BLOWER COILS

Date: 05/10/89

Part No.	Description	B	B	B	B	B	B	B	B	B	B
		C	C	C	C	C	C	C	C	C	C
		4	4	4	4	4	4	4	4	4	4
		8	8	8	8	8	8	8	8	8	8
		A	A	A	A	A	A	A	A	A	A
			1	1	2	3	0	1	3	0	1
			0	5	0	0	9	5	0	9	8
104-779	Angle	X	X	X	X	X	X	X	X	X	X
104-784	Angle	X	X	X	X	X	X	X	X	X	X
104-785	Angle	X	X	X	X	X	X	X	X	X	X
144-129	Diffuser	X	X	X	X	X	X	X	X	X	X
151-082	Blower Housing	X	X	X	X	X	X	X	X	X	X
4038-112	Wiring Diagram	X									
4038-121	Wiring Diagram		X								
4038-131	Wiring Diagram			X							
4038-142	Wiring Diagram				X						
4038-162	Wiring Diagram					X					
4038-220	Wiring Diagram						X	X			
4038-234	Wiring Diagram								X		
4038-320	Wiring Diagram									X	
4038-340	Wiring Diagram										X
5060-020	Evaporator Coil	X	X	X	X	X	X	X	X	X	X
5152-059	Blower Wheel 10-10	X	X	X	X	X	X	X	X	X	X
5210-006	Strainer	X	X	X	X	X	X	X	X	X	X
5651-036	Check Valve	X	X	X	X	X	X	X	X	X	X
5811-009	Capillary Tube	4	4	4	4	4	4	4	4	4	4
7004-015	Filter 24x24	X	X	X	X	X	X	X	X	X	X
8106-013	Motor--Blower 1/2 hp	X	X	X	X	X	X	X	X	X	X
8200-033	Motor Mount Band	X	X	X	X	X	X	X	X	X	X
8200-034	Motor Mount Arm	3	3	3	3	3	3	3	3	3	3
8201-013	Relay--Emergency Heat			X	X	X			X		X
8201-014	Relay--Blower	X	X	X	X	X	X	X	X	X	X
8201-045	Relay--Time Delay	X	X	X	X	X					
8401-001	Contact--Heat 3ph							1			
8401-002	Contact--Heat									1	
8401-006	Contact--Heater 20A		1	2	2	3					2
8401-010	Contact--Heat 3ph						1		2		
8402-025	Thermal Cutoff		2	3	4	6	3	3	6	3	6
8402-033	Limit Switch L140-2.5		X	X	X	X	X	X	X	X	X
8407-003	Transformer 9KW 460V 3ph									X	X
8407-036	Transformer	X	X	X	X	X	X	X	X	X	X
8552-002	Capacitor 5/370V	X	X	X	X	X	X	X	X	X	X
8604-024	Heat Strip 10KW		1		2						
8604-025	Heat Strip 15KW			1		2		1	2		
8604-032	Heat Strip 9KW 460V									1	2
8604-035	Heat Strip 9KW						1				
8607-010	Terminal Block	X	X	X	X	X	X	X	X	X	X
8607-013	Terminal Block	X	X								
8607-014	Terminal Block 3ph						X	X			
8607-015	Phenolic Insulator 460V									X	X
8607-017	Terminal Block 460V									X	X
8614-006	Fuse--Heater 30A			2							
8614-007	Fuse--Heater 60A			2	4	6			3		
8614-017	Fuse Block 15KW			X							
8614-018	Fuse Block 20KW				X						
8614-019	Fuse Block 30KW					X					
8614-020	Fuse Block 30KW 3ph									X	
8614-033	Fuse--Heater 35A 3ph								3		
8614-036	Circuit Breaker	X	X	X	X	X	X	X	X	X	X

PARTS LIST
SPLIT SYSTEM BLOWER COILS

Date: 5/12/89

Part No.	Description	B	B	B	B	B	B	B	B	B	B
		C	C	C	C	C	C	C	C	C	C
		6	6	6	6	6	6	6	6	6	6
		0	0	0	0	0	0	0	0	0	0
		A	A	A	A	A	A	A	A	A	A
			A	A	A	A	B	B	B	C	C
			1	1	2	3	0	1	3	0	1
			0	5	0	0	9	5	0	9	8
4038-112	Wiring Diagram	X									
4038-121	Wiring Diagram		X								
4038-131	Wiring Diagram			X							
4038-143	Wiring Diagram				X						
4038-163	Wiring Diagram					X					
4038-220	Wiring Diagram						X	X			
4038-234	Wiring Diagram								X		
4038-320	Wiring Diagram									X	
4038-340	Wiring Diagram										X
5060-032	Evaporator Coil	X	X	X	X	X	X	X	X	X	X
5152-059	Blower Wheel 10-10	X	X	X	X	X	X	X	X	X	X
5210-006	Strainer	X	X	X	X	X	X	X	X	X	X
5651-036	Check Valve	X	X	X	X	X	X	X	X	X	X
5811-002	Capillary Tube	8	8	8	8	8	8	8	8	8	8
7004-015	Filter 24x24	X	X	X	X	X	X	X	X	X	X
8106-013	Motor--Blower 1/2 hp	X	X	X	X	X	X	X	X	X	X
8200-033	Motor Mount Band	X	X	X	X	X	X	X	X	X	X
8200-034	Motor Mount Arm	3	3	3	3	3	3	3	3	3	3
8201-013	Relay--Emergency Heat			X	X	X			X		X
8201-014	Relay--Blower	X	X	X	X	X	X	X	X	X	X
8201-045	Relay--Time Delay	X	X	X	X	X					
8401-001	Contact--Heat 3ph							1	1		
8401-002	Contact--Heat					2				1	
8401-006	Contact--Heater 20A		1	2	2						2
8401-010	Contact--Heat 3ph						1		1		
8402-025	Thermal Cutoff		2	3	4	6	3	3	6	3	6
8402-033	Limit Switch L140-2.5		X	X	X	X	X	X	X	X	X
8407-003	Transformer 9KW 460V 3ph										
8407-036	Transformer	X	X	X	X	X	X	X	X	X	X
8552-002	Capacitor 5/370V	X	X	X	X	X	X	X	X	X	X
8604-024	Heat Strip 10KW		1		2						
8604-025	Heat Strip 15KW			1		2		1	2		
8604-032	Heat Strip 9KW 460V									1	2
8604-035	Heat Strip 9KW						1				
8607-010	Terminal Block	X	X	X	X	X	X	X	X	X	X
8607-013	Terminal Block	X	X								
8607-014	Terminal Block 3ph						X	X		X	X
8607-015	Phenolic Insulator 460V									X	X
8607-017	Terminal Block 460V									X	X
8614-006	Fuse--Heater 30A			2							
8614-007	Fuse--Heater 60A			2	4	6			3		
8614-017	Fuse Block 15KW			X							
8614-018	Fuse Block 20KW				X						
8614-019	Fuse Block 30KW					X					
8614-020	Fuse Block 30KW 3ph								X		
8614-033	Fuse--Heater 35A 3ph								3		
8614-036	Circuit Breaker	X	X	X	X	X	X	X	X	X	X

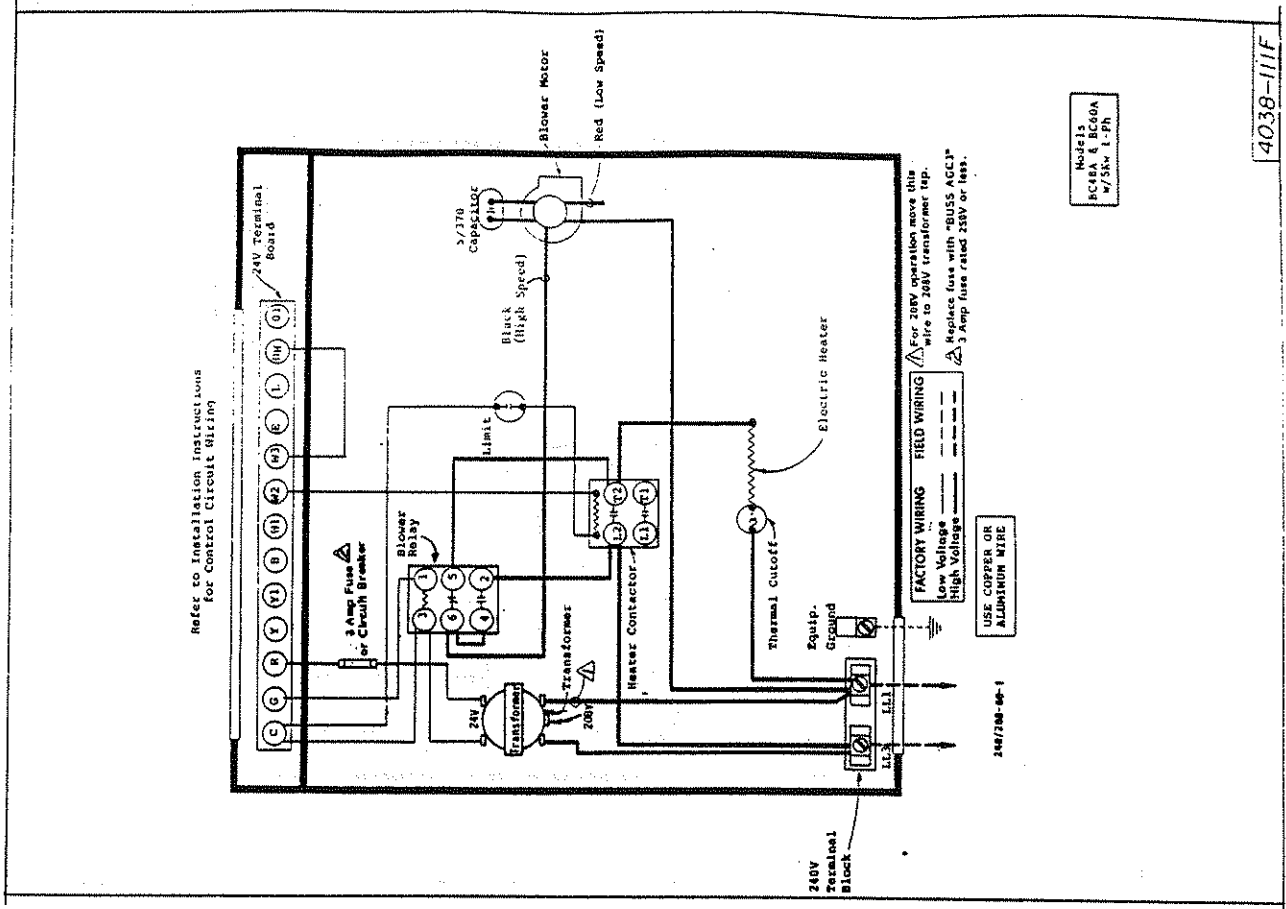
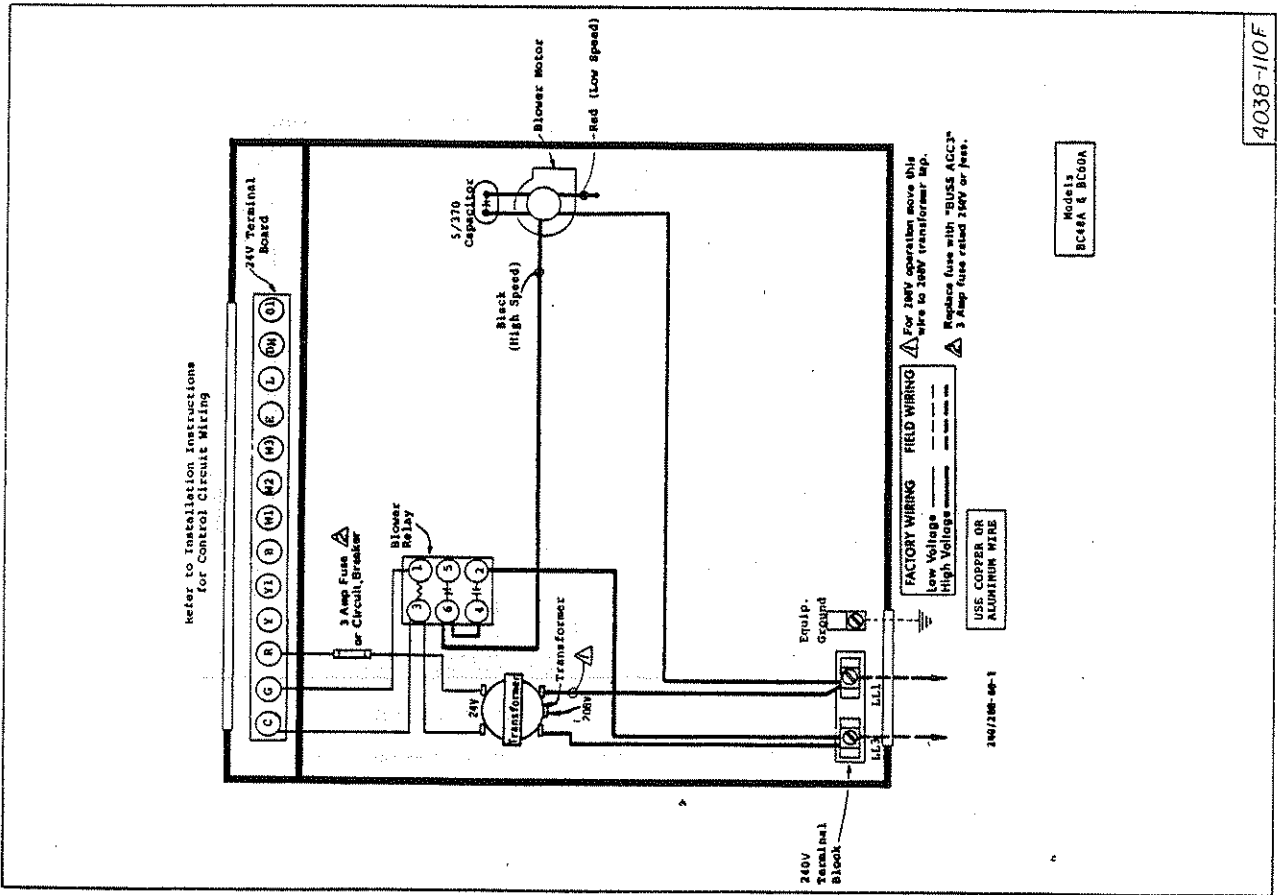

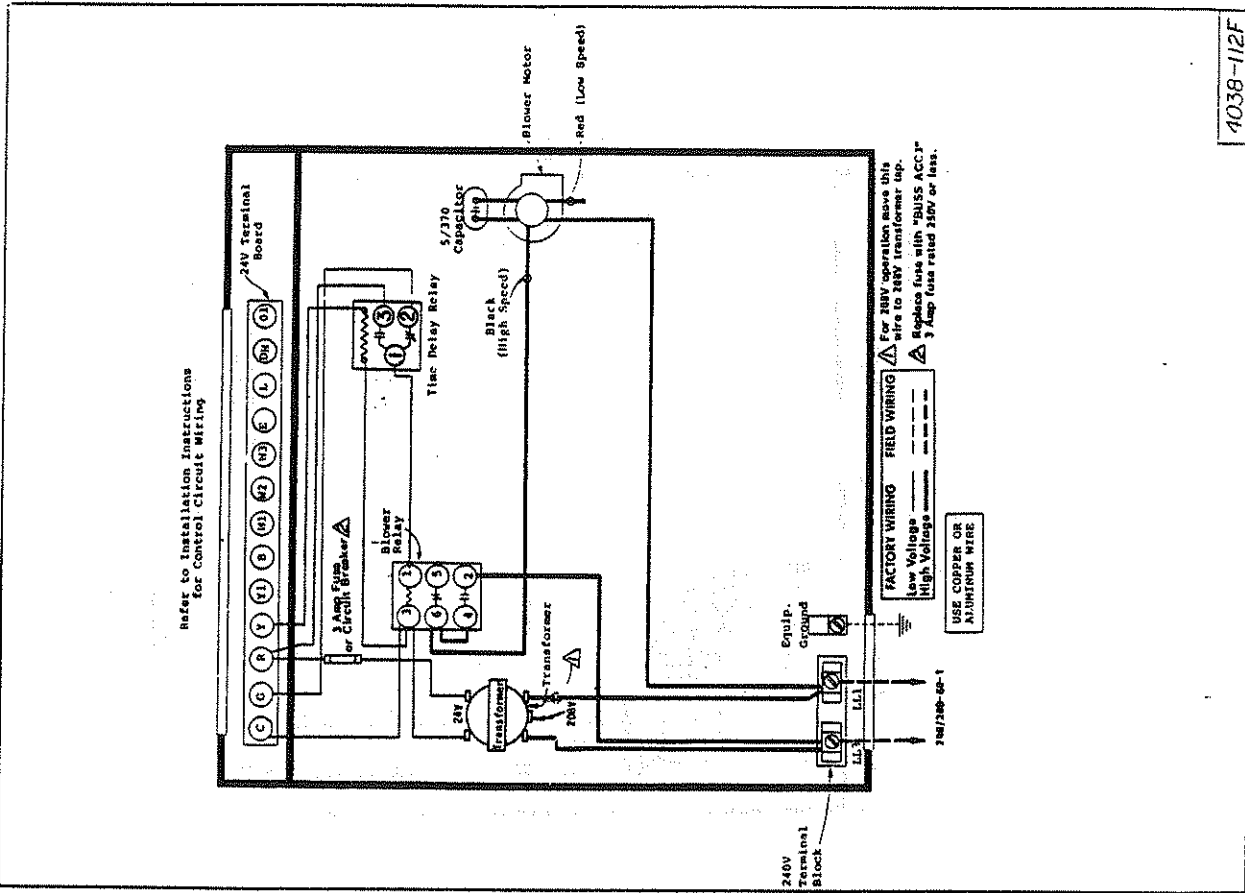

4038-112F

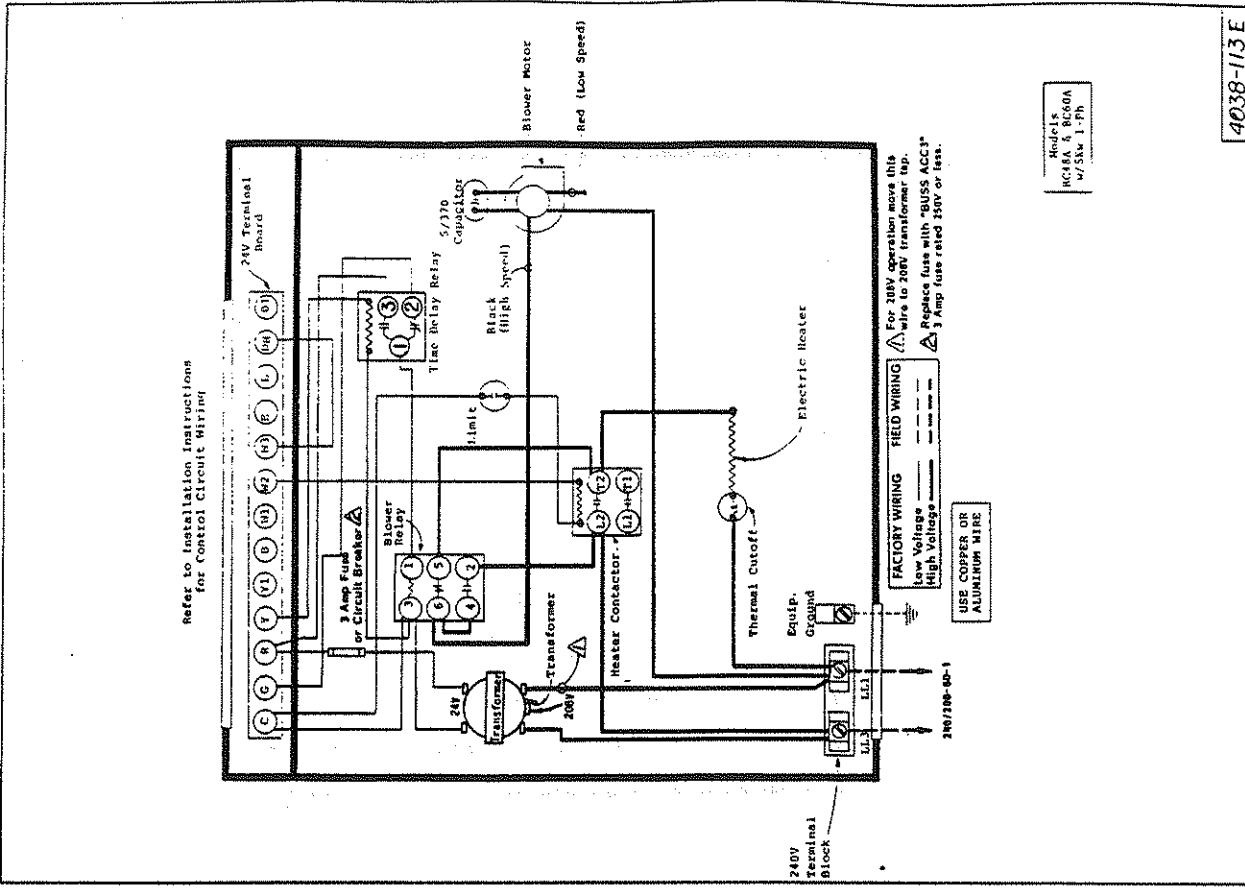

BUSS ACC
REASON
W/58w 1-PH

4038-113E

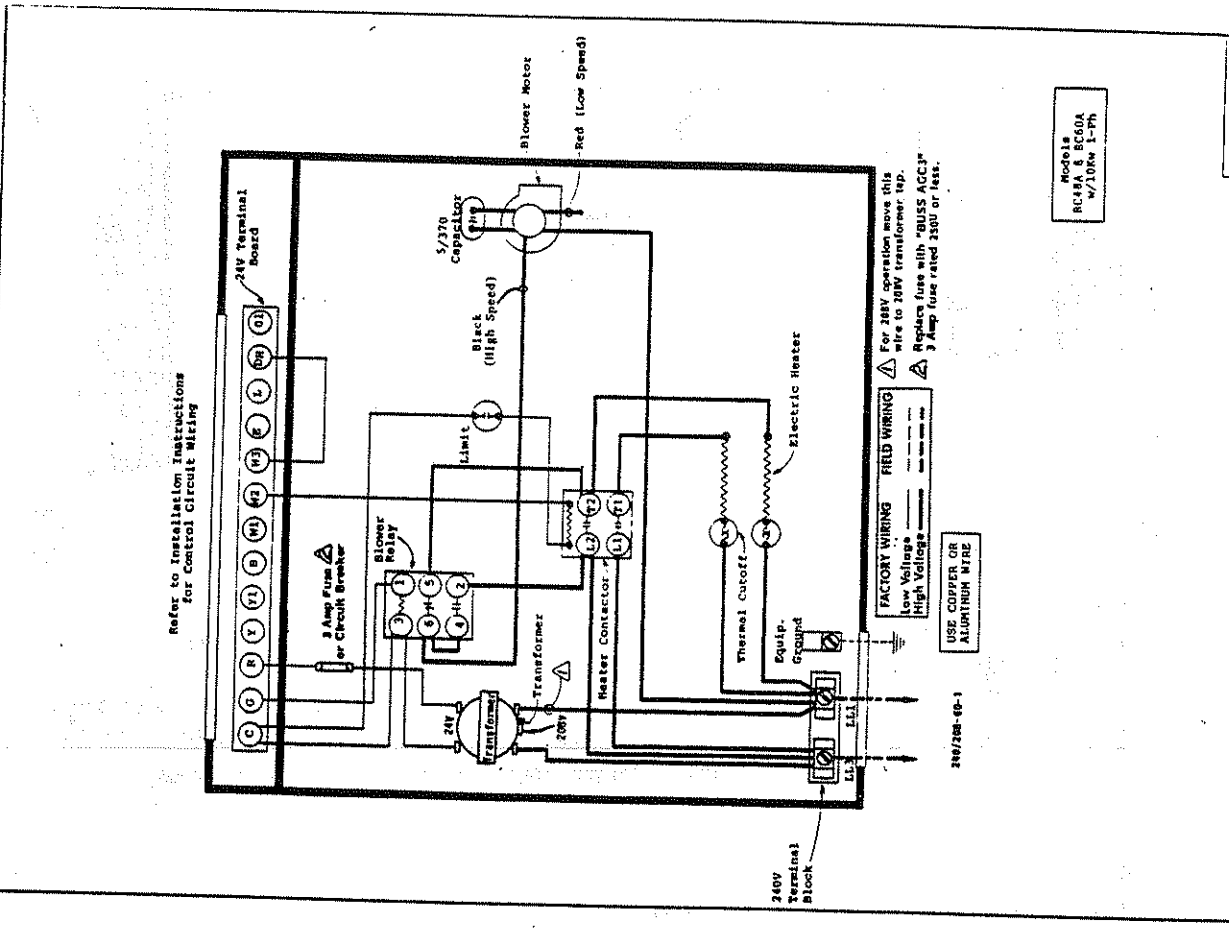
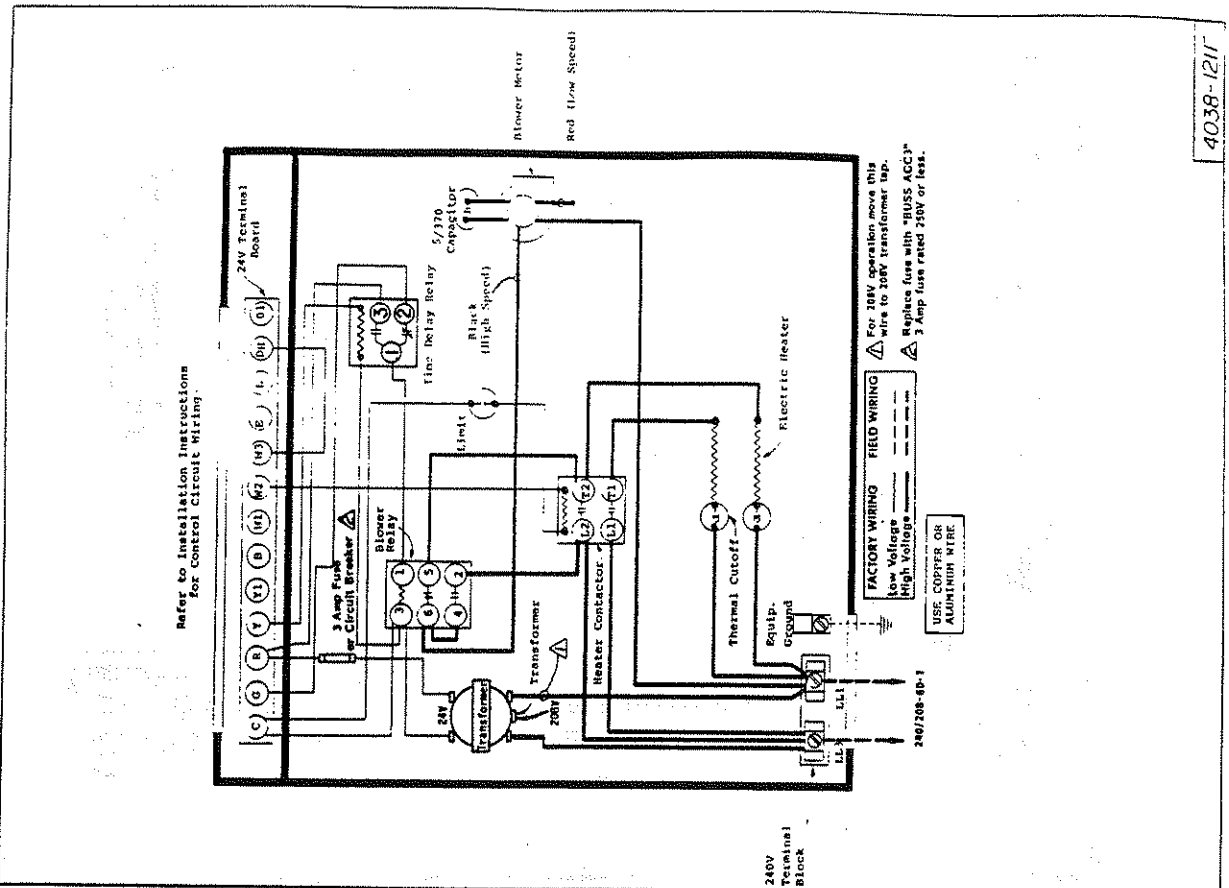

Models
RC48A & BC60A
w/10RW 1-Ph

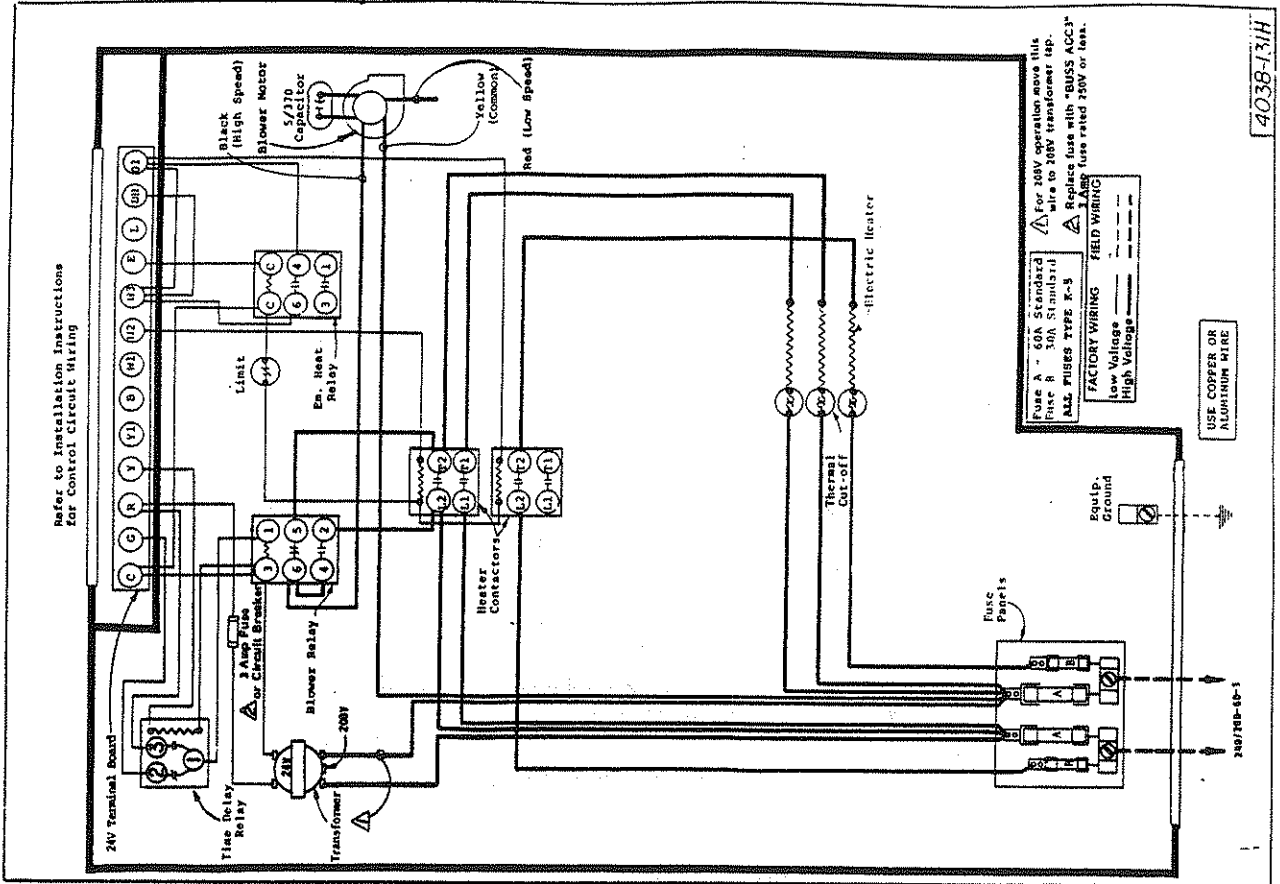
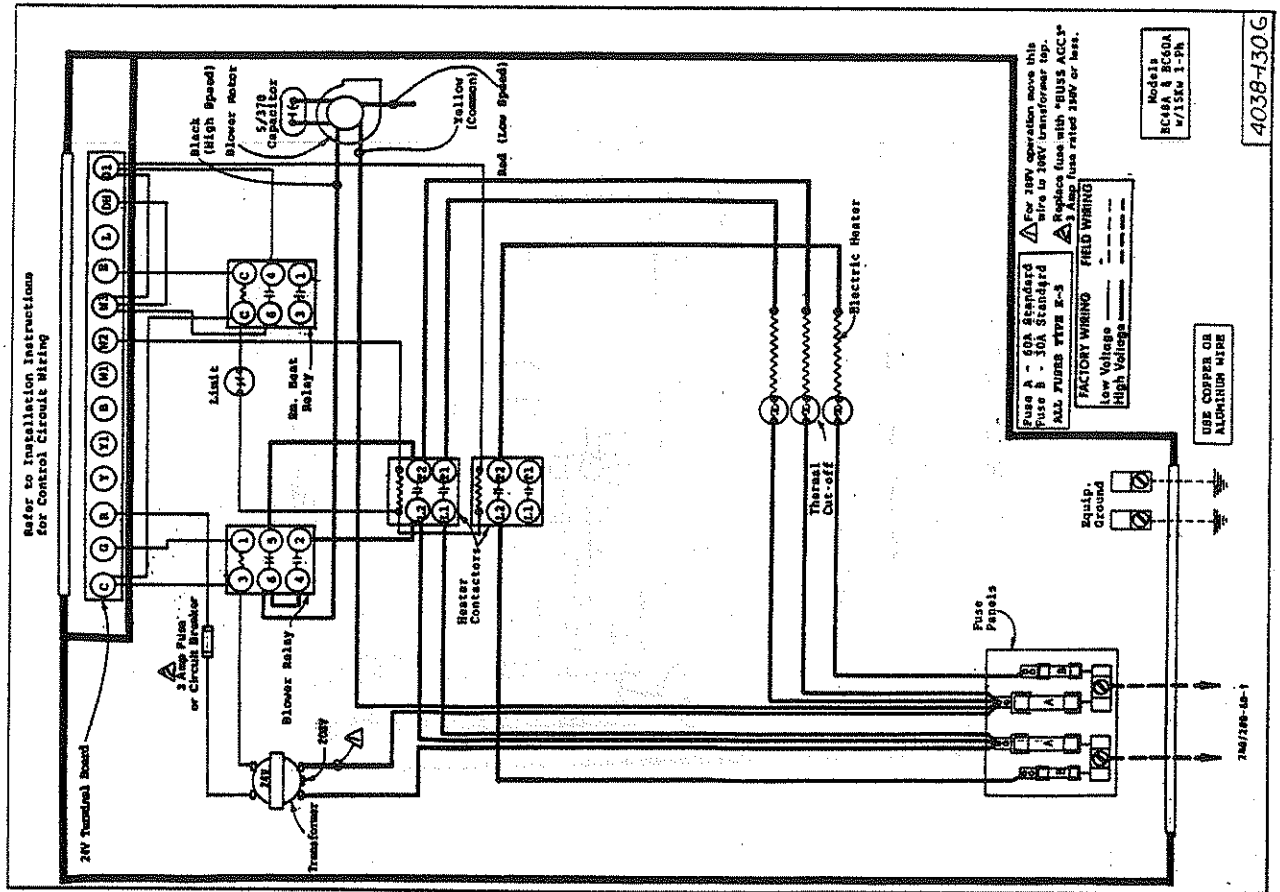

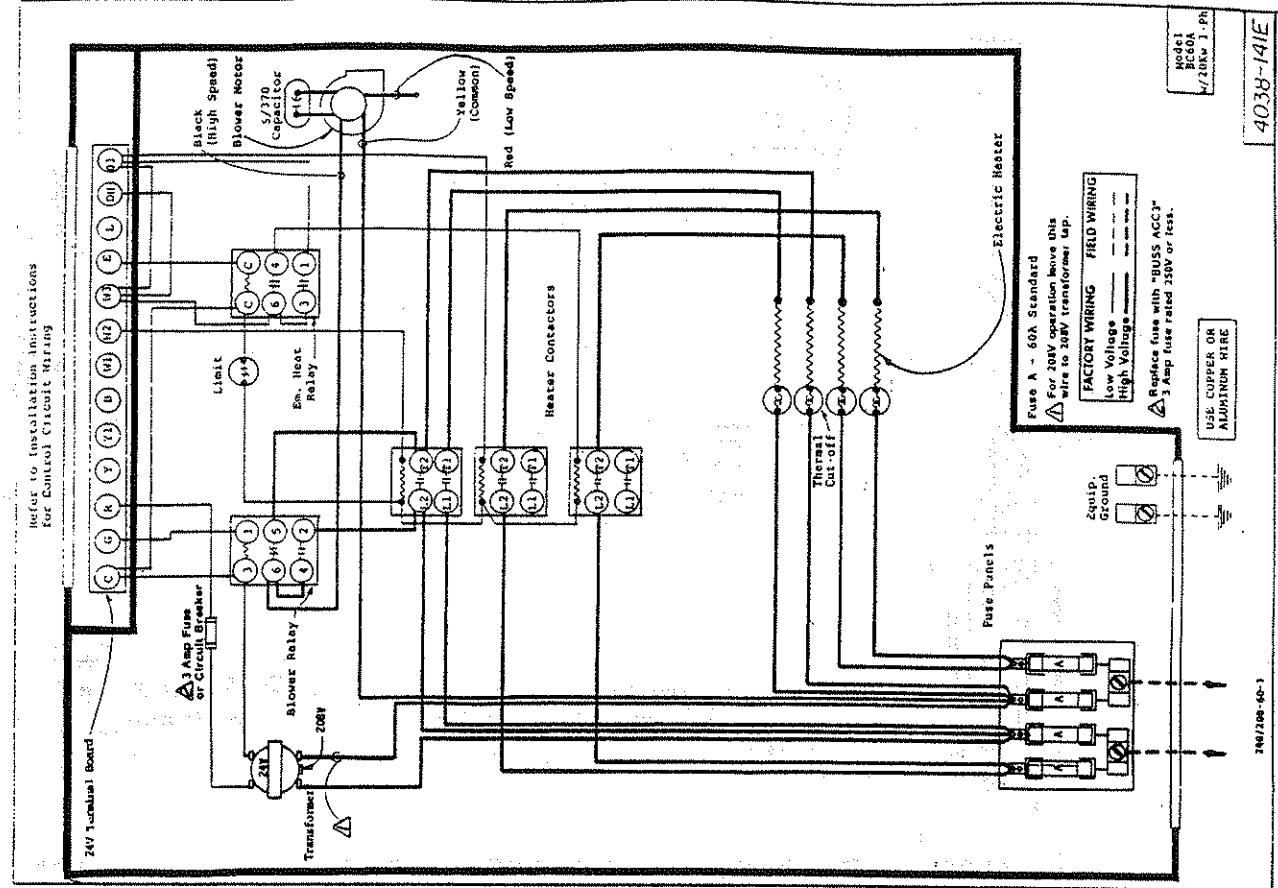
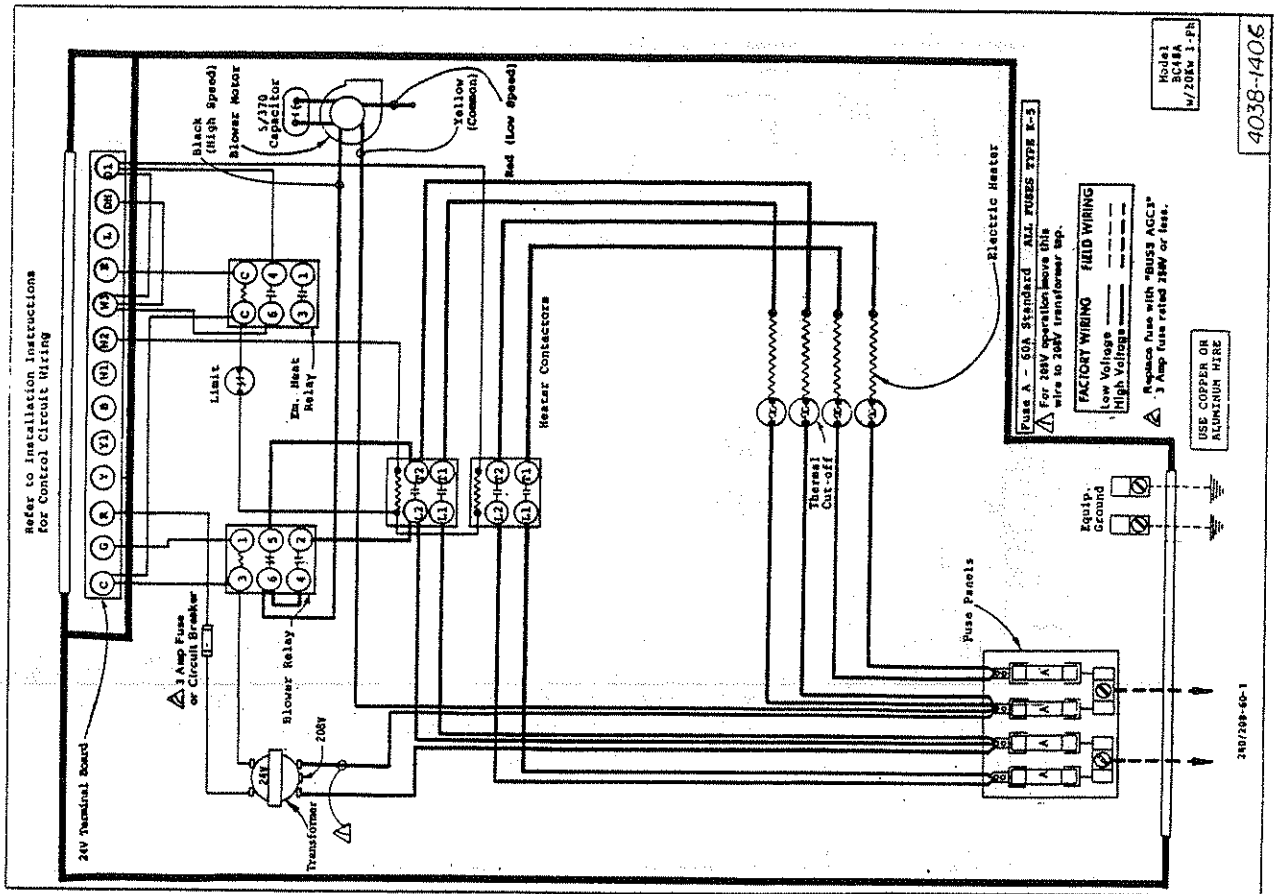

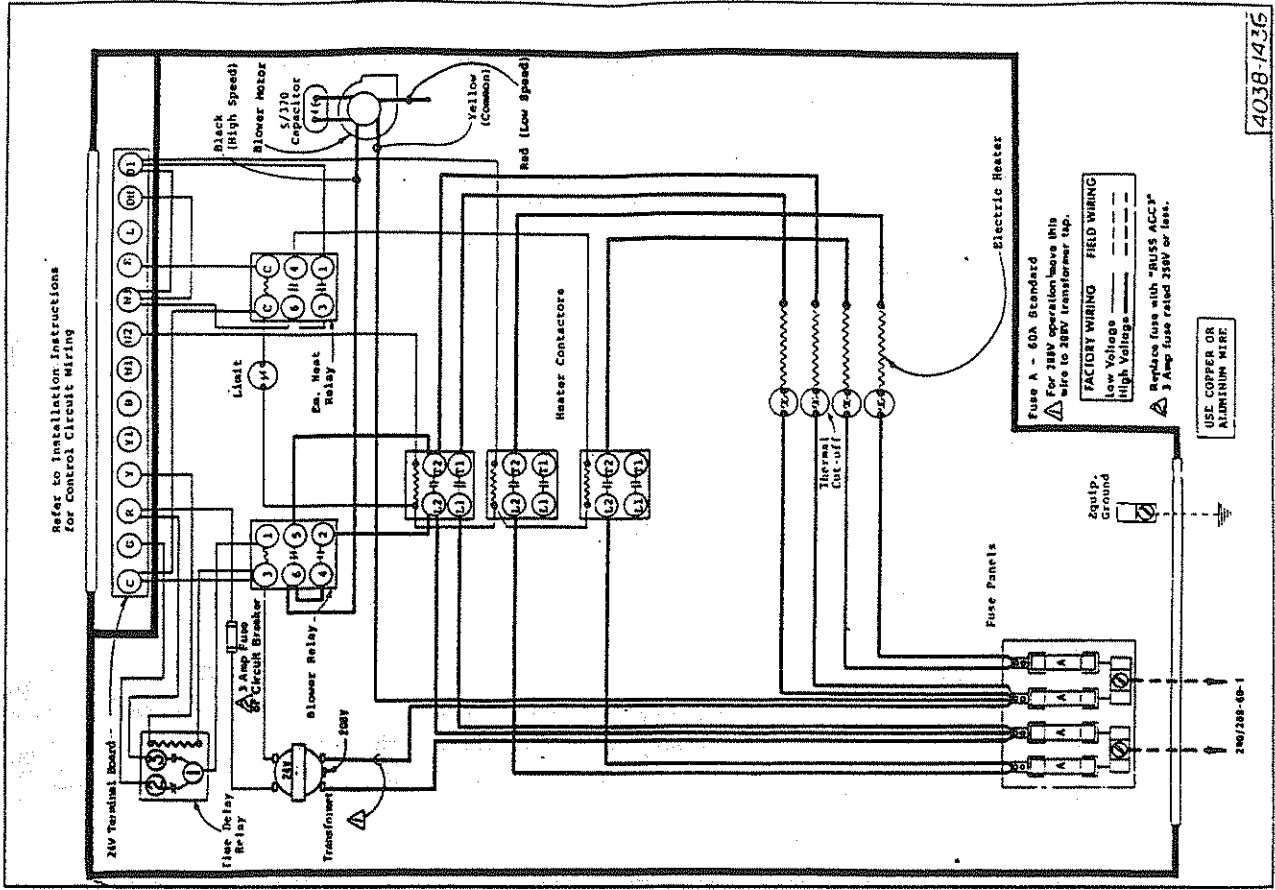
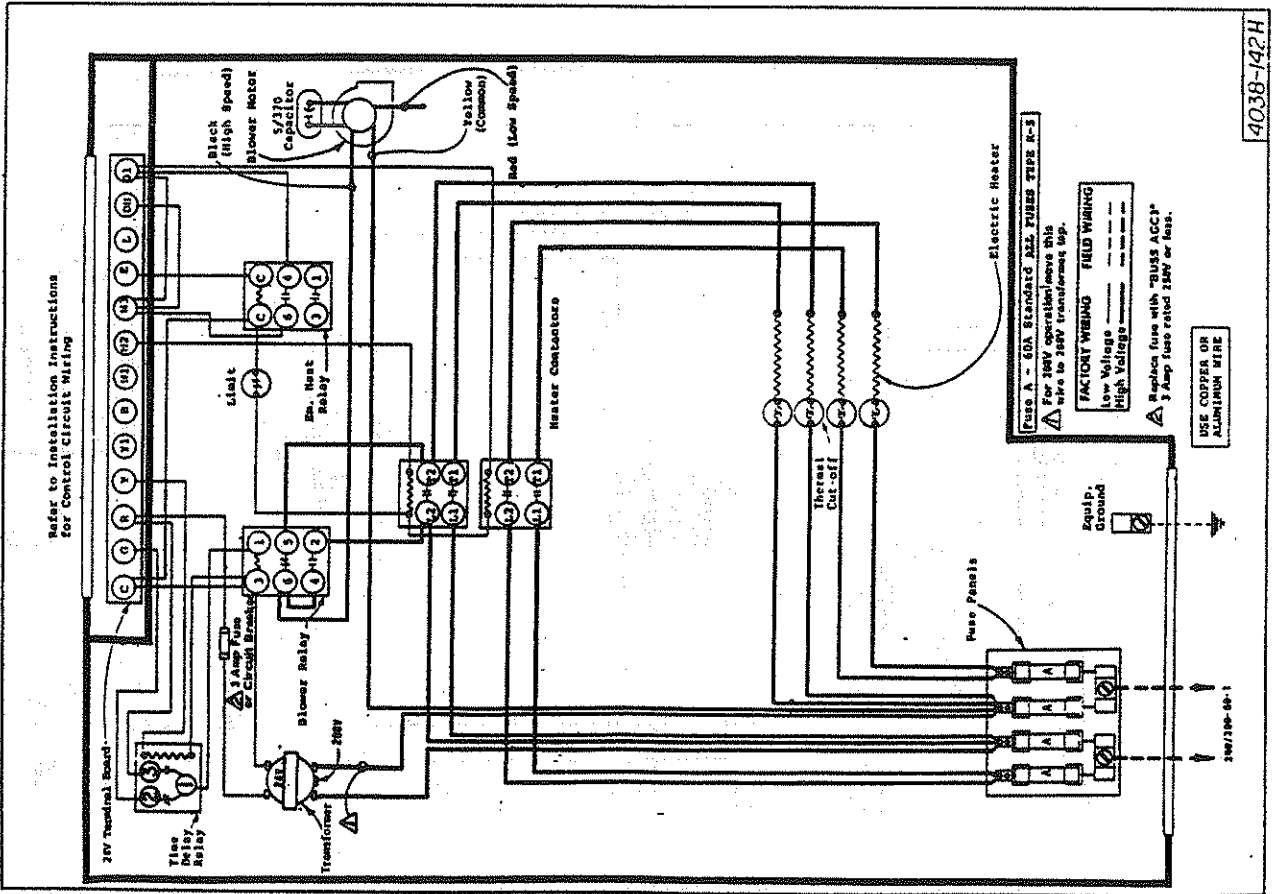

Refer to Installation Instructions
for Control Circuit Wiring

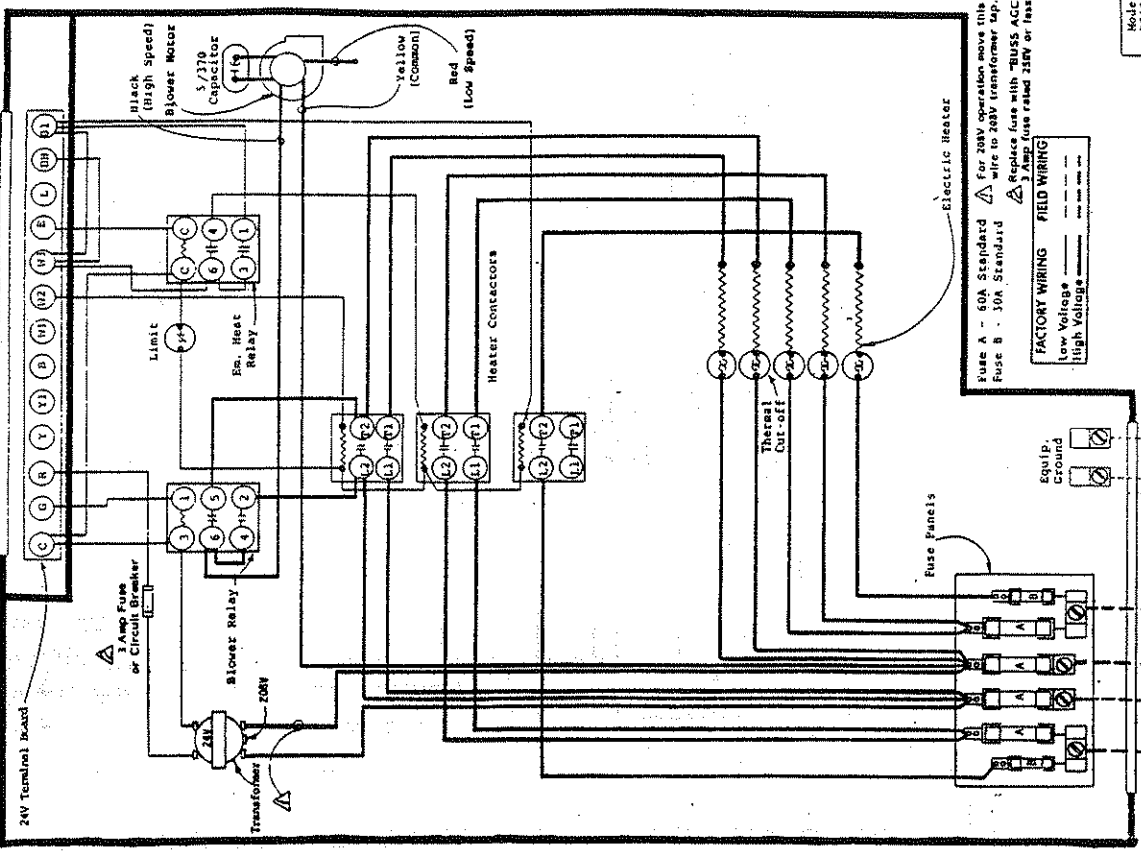

Fuse A - 60A Standard
Fuse B - 30A Standard

For 248V operation move this wire to 248V transformer tap.
Replace fuse with "BUSS AGC3" 3 Amp fuse rated 248V or less.

FACTORY WIRING
Low Voltage
High Voltage

Model
BC60A
4/235W 1-Ph

4038-151E

USE COPPER OR
ALUMINUM WIRE

Refer to Installation Instructions
for Control Circuit Wiring

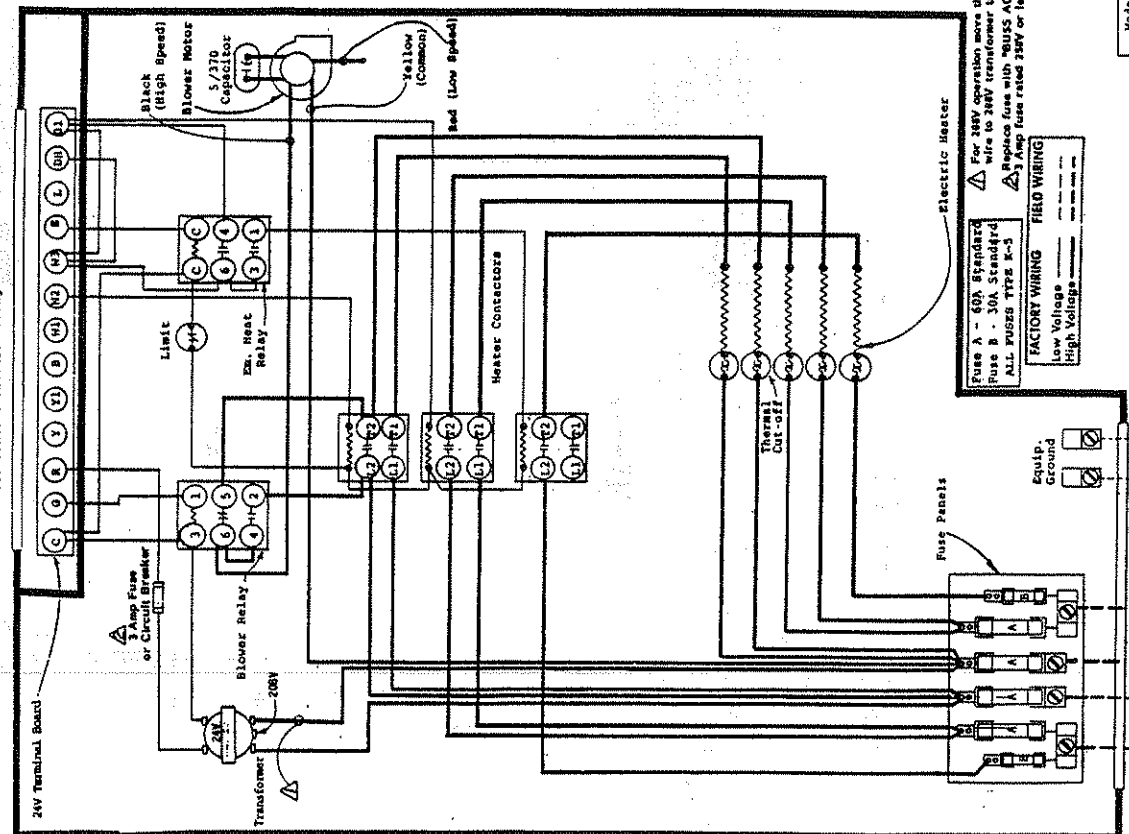

Fuse A - 60A Standard
Fuse B - 30A Standard

For 188V operation move this wire to 248V transformer tap.
Replace fuse with "BUSS AGC3" 3 Amp fuse rated 248V or less.

FACTORY WIRING
Low Voltage
High Voltage

Model
BC48A
4/235W 1-Ph

4038-150H

USE COPPER OR
ALUMINUM WIRE

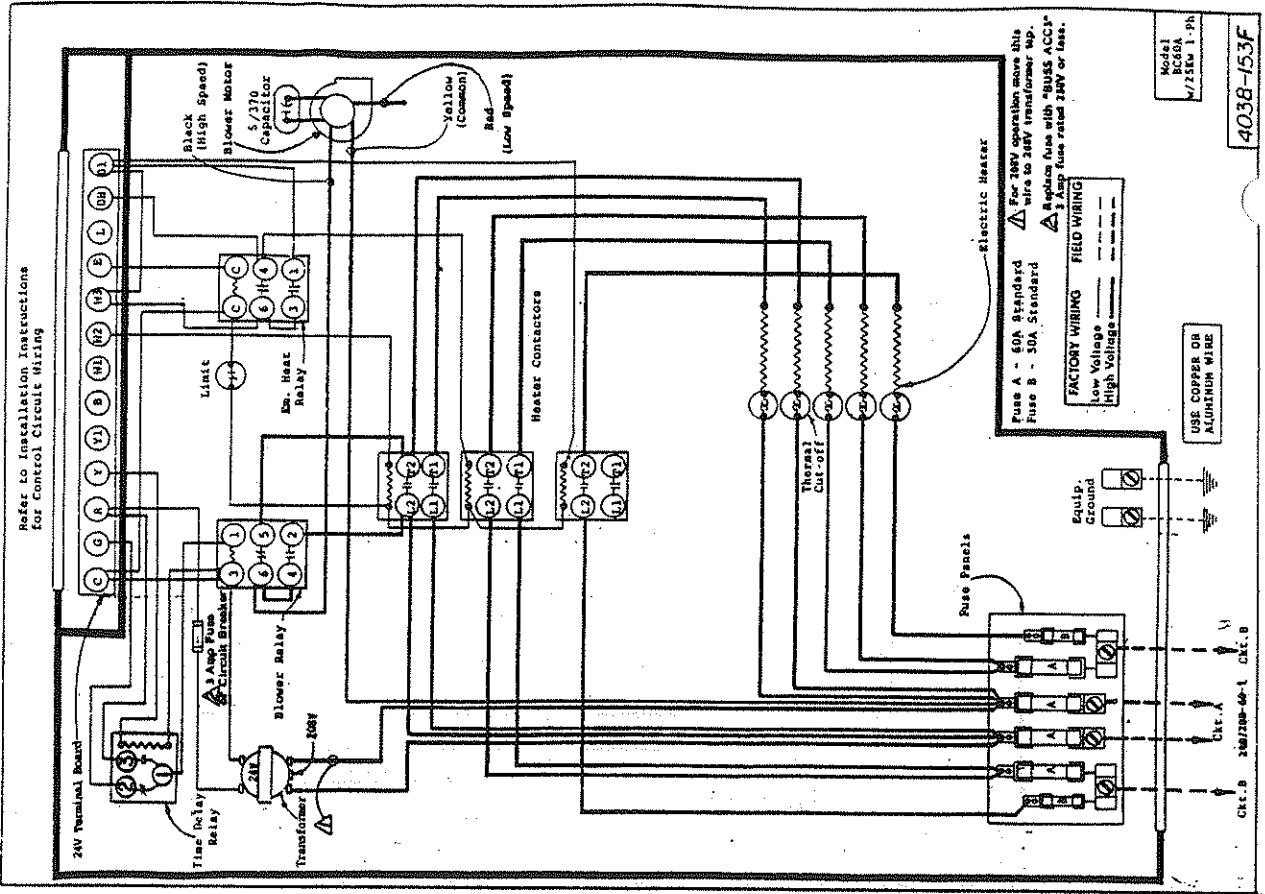
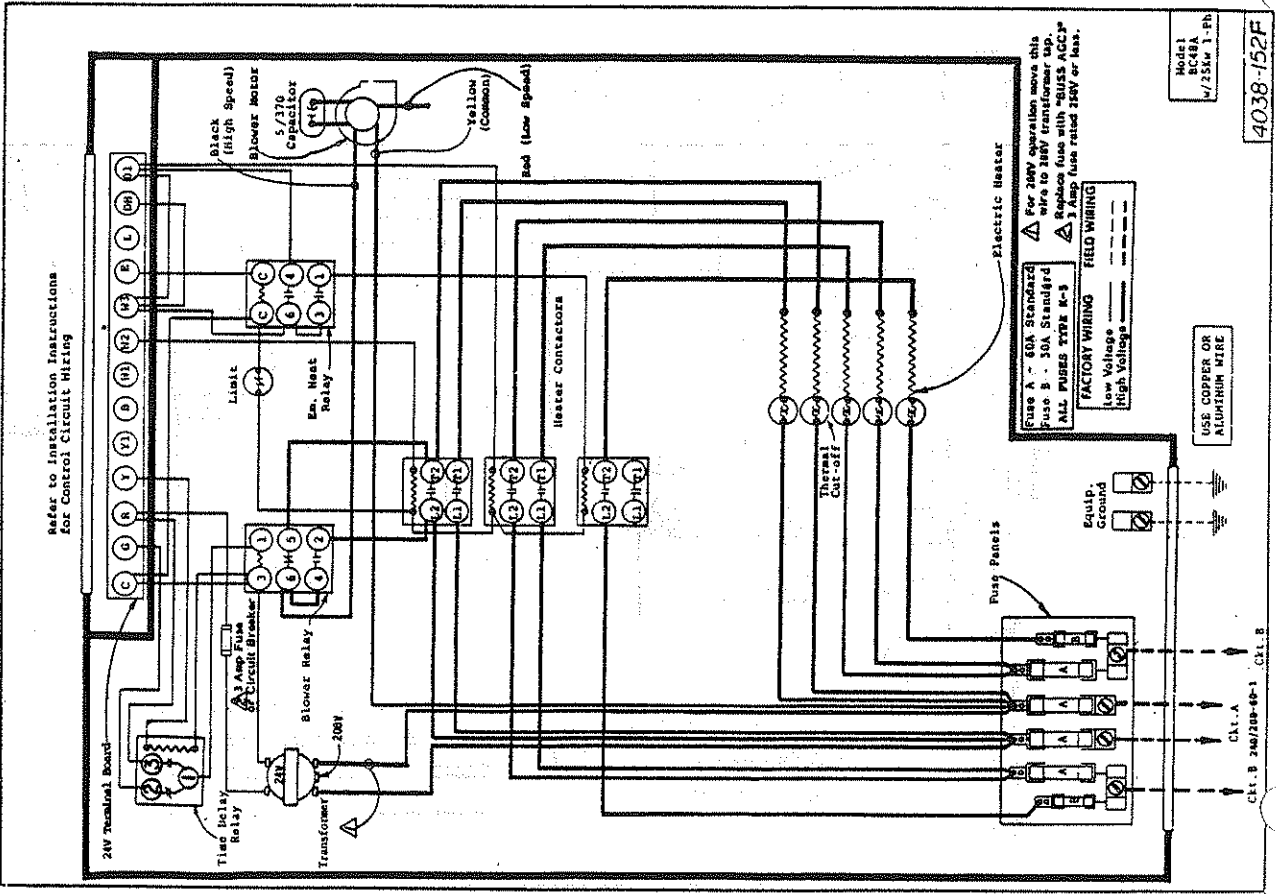

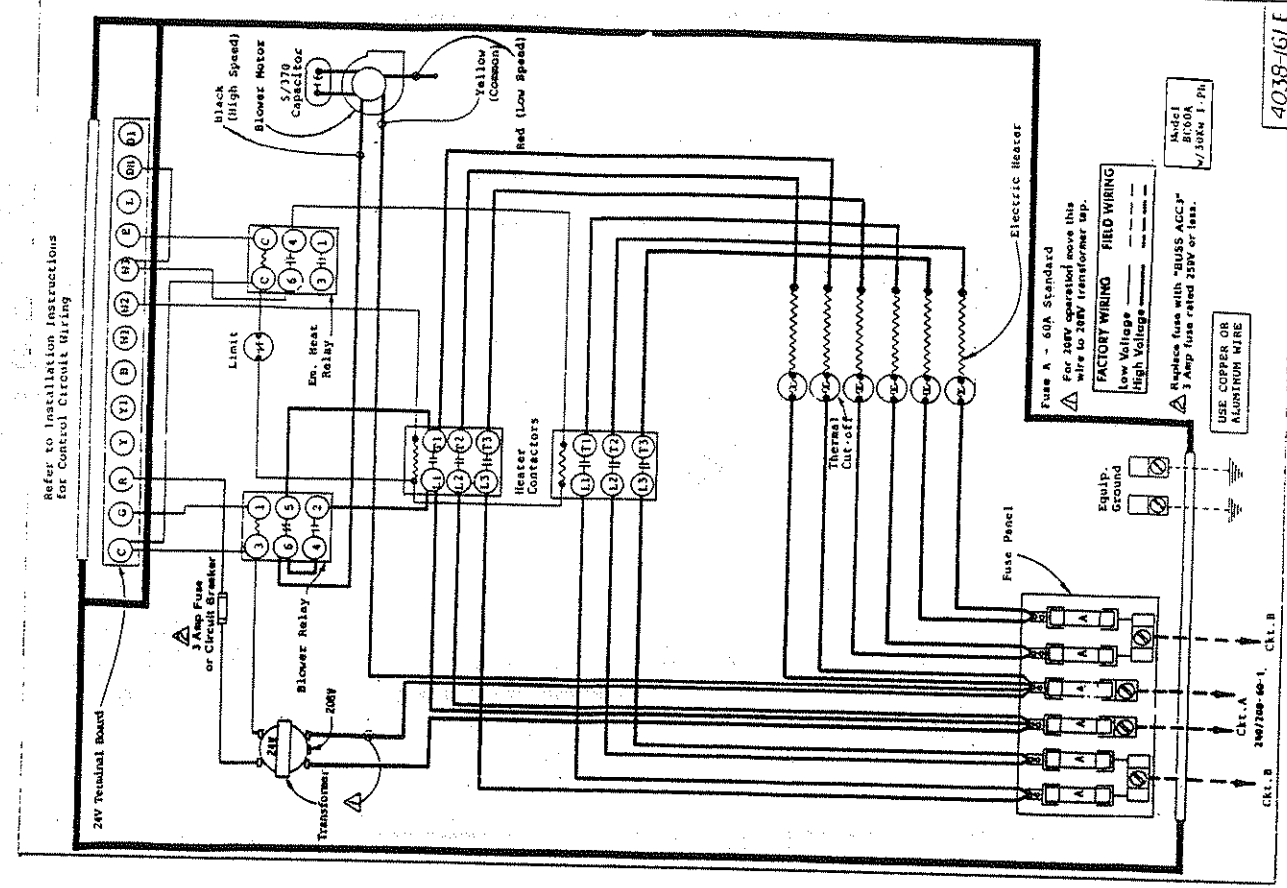
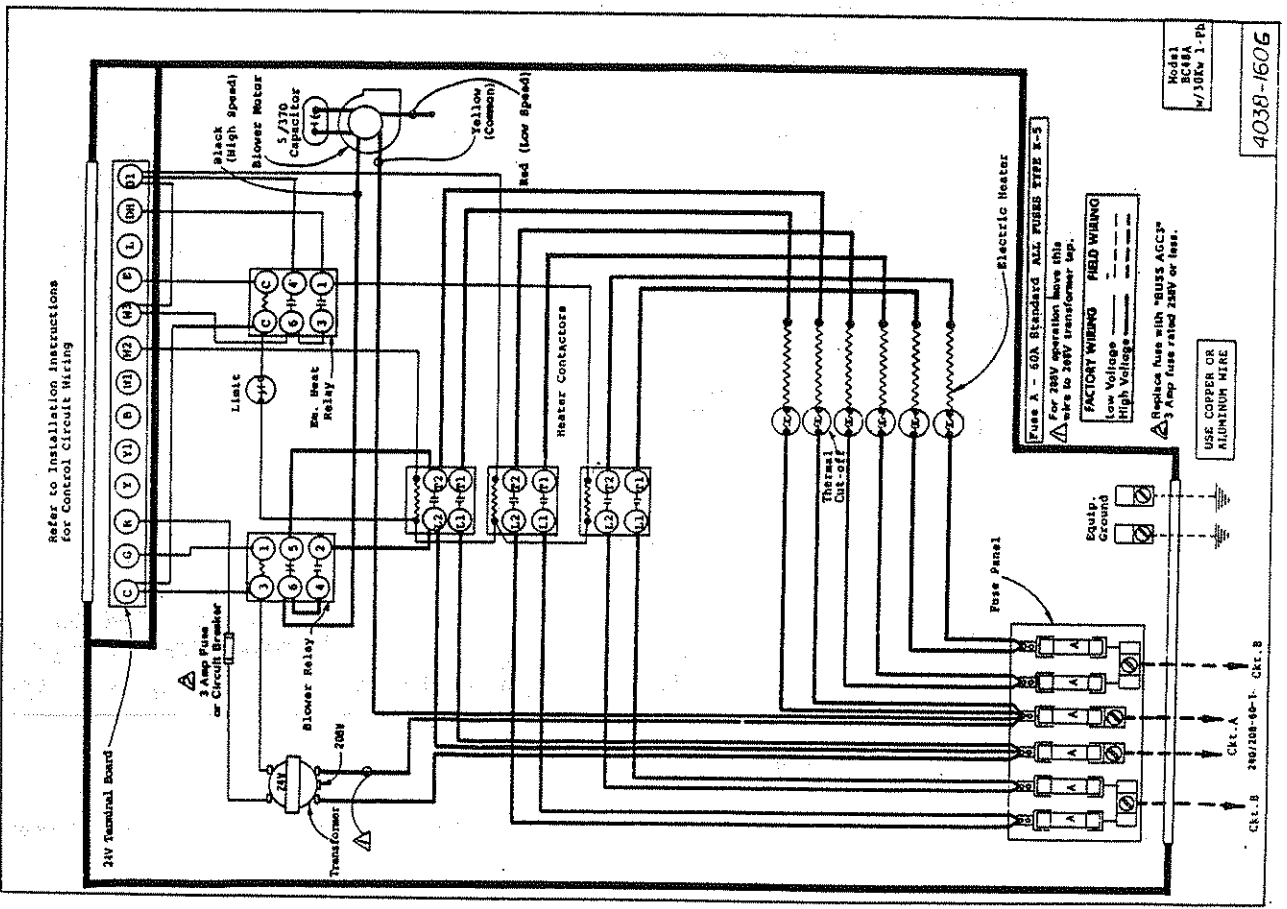

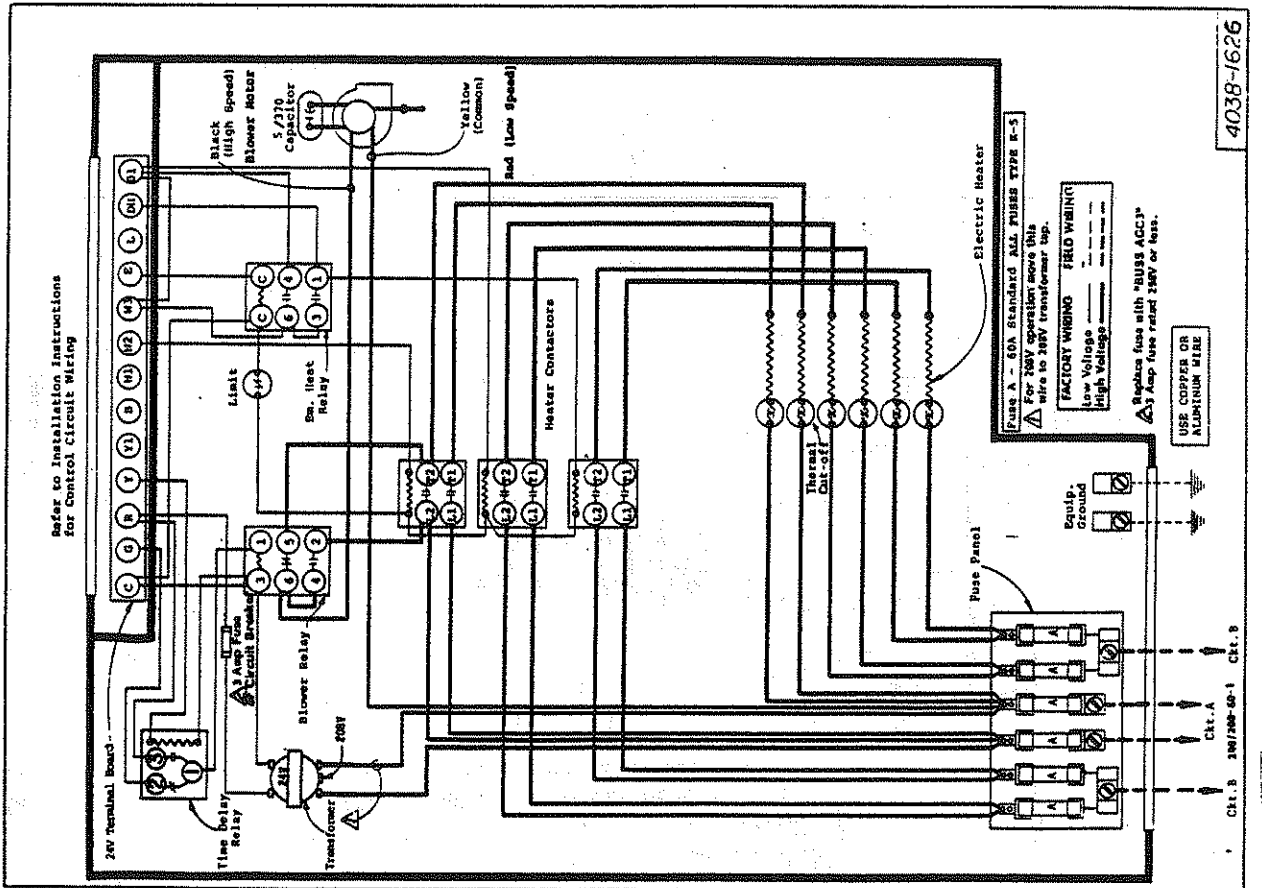
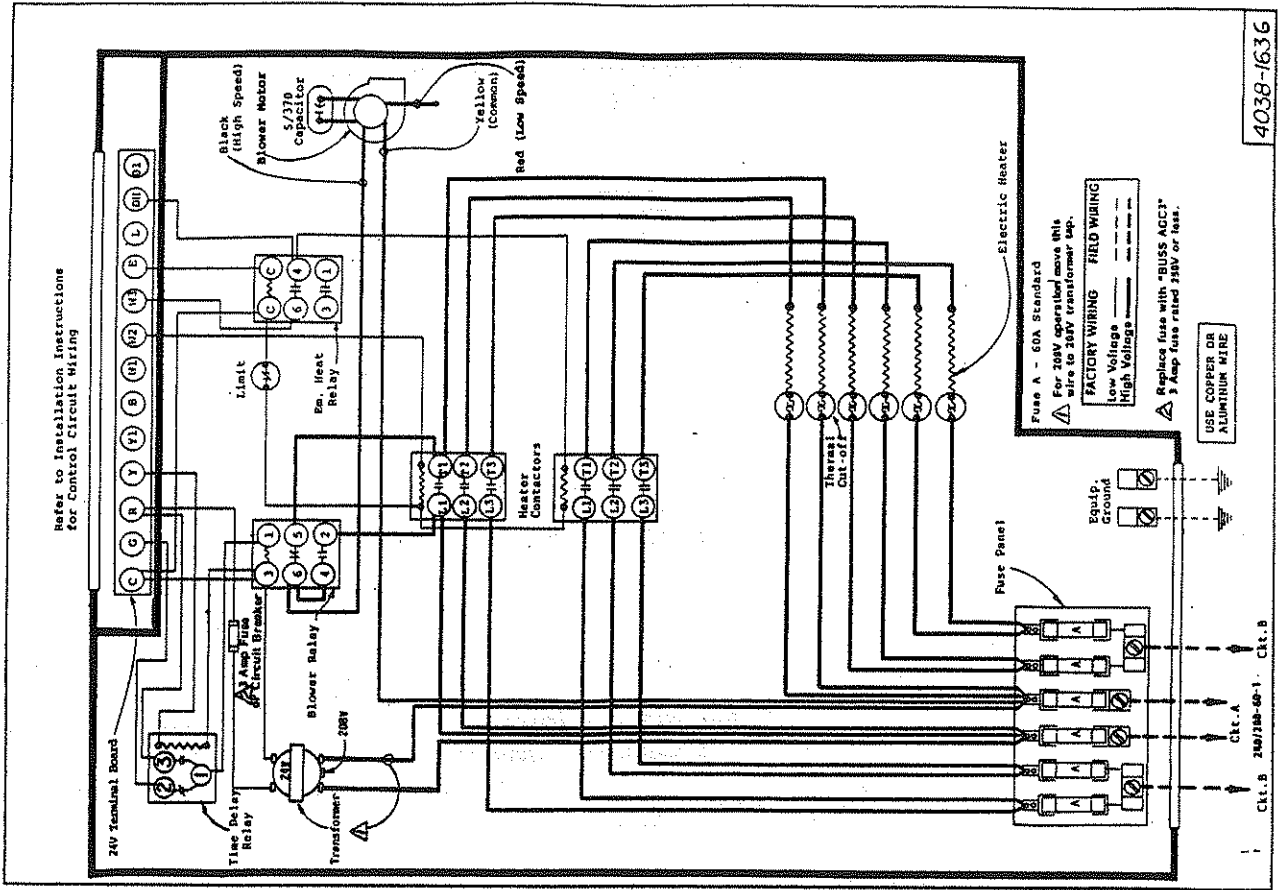

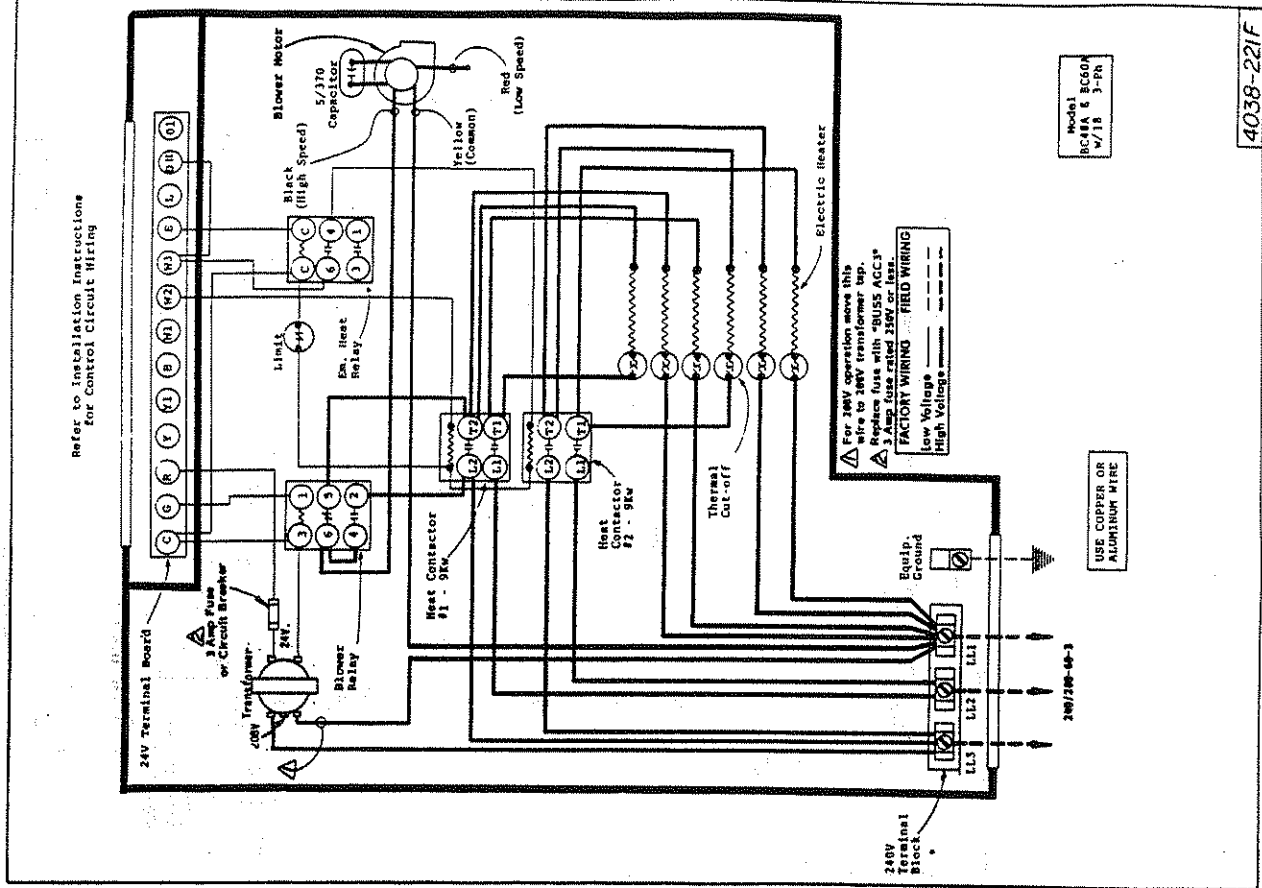
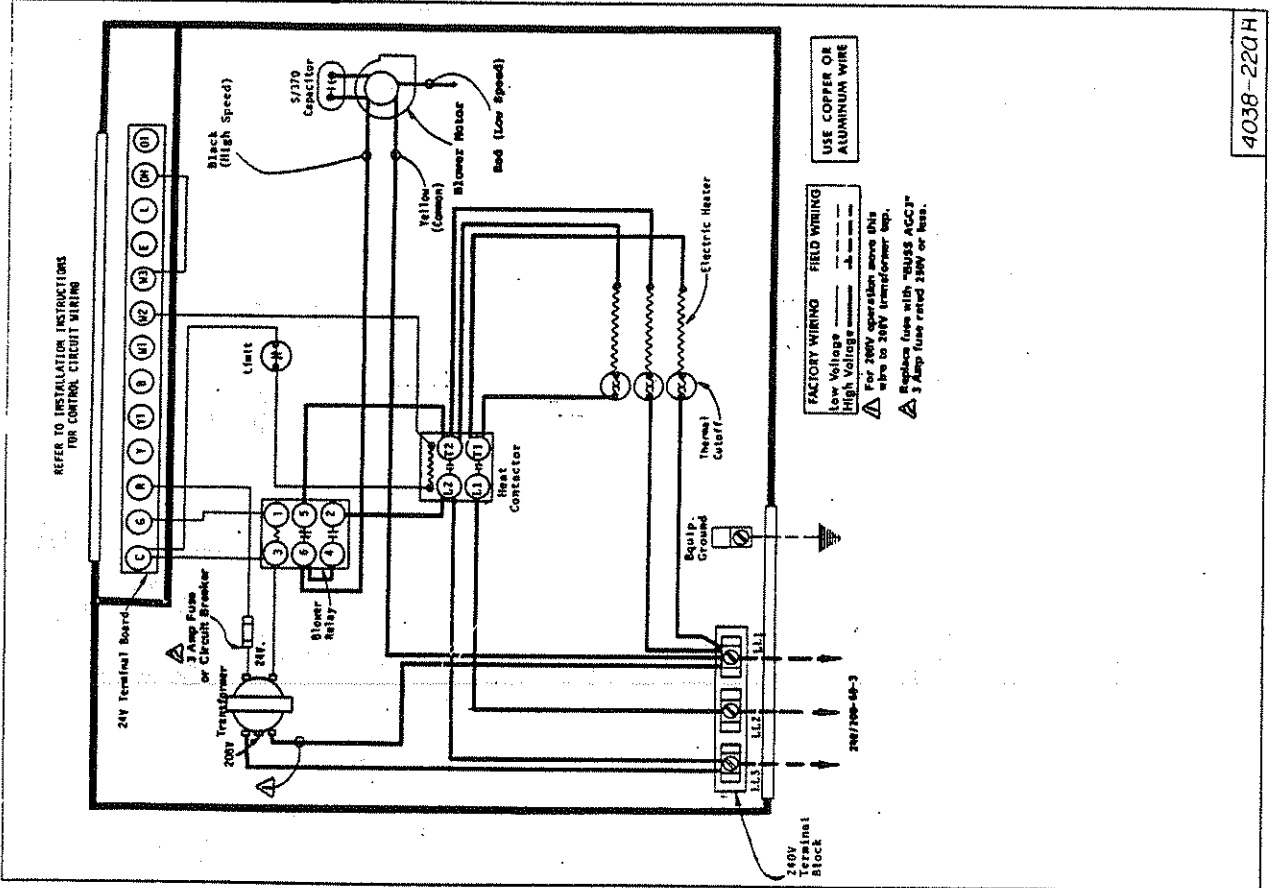

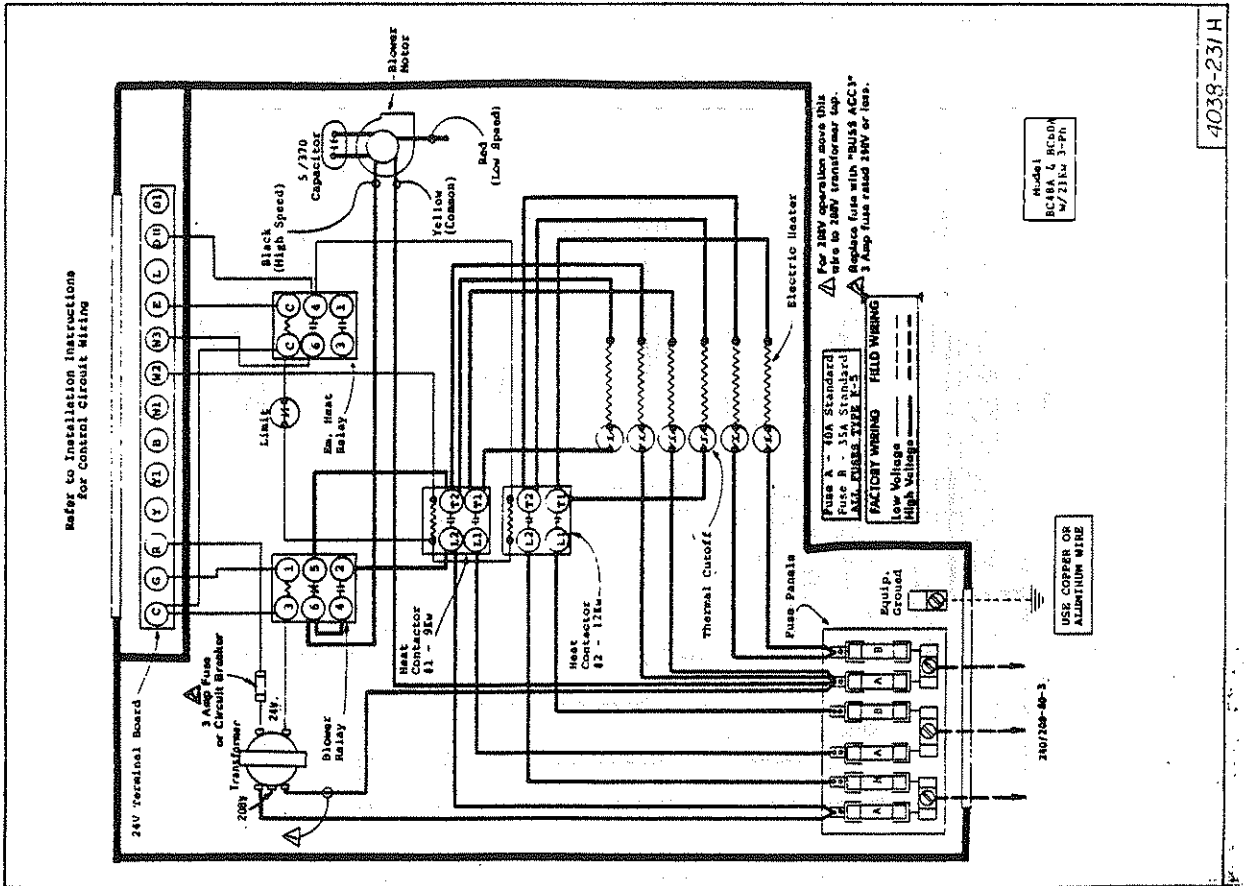

4038-231H

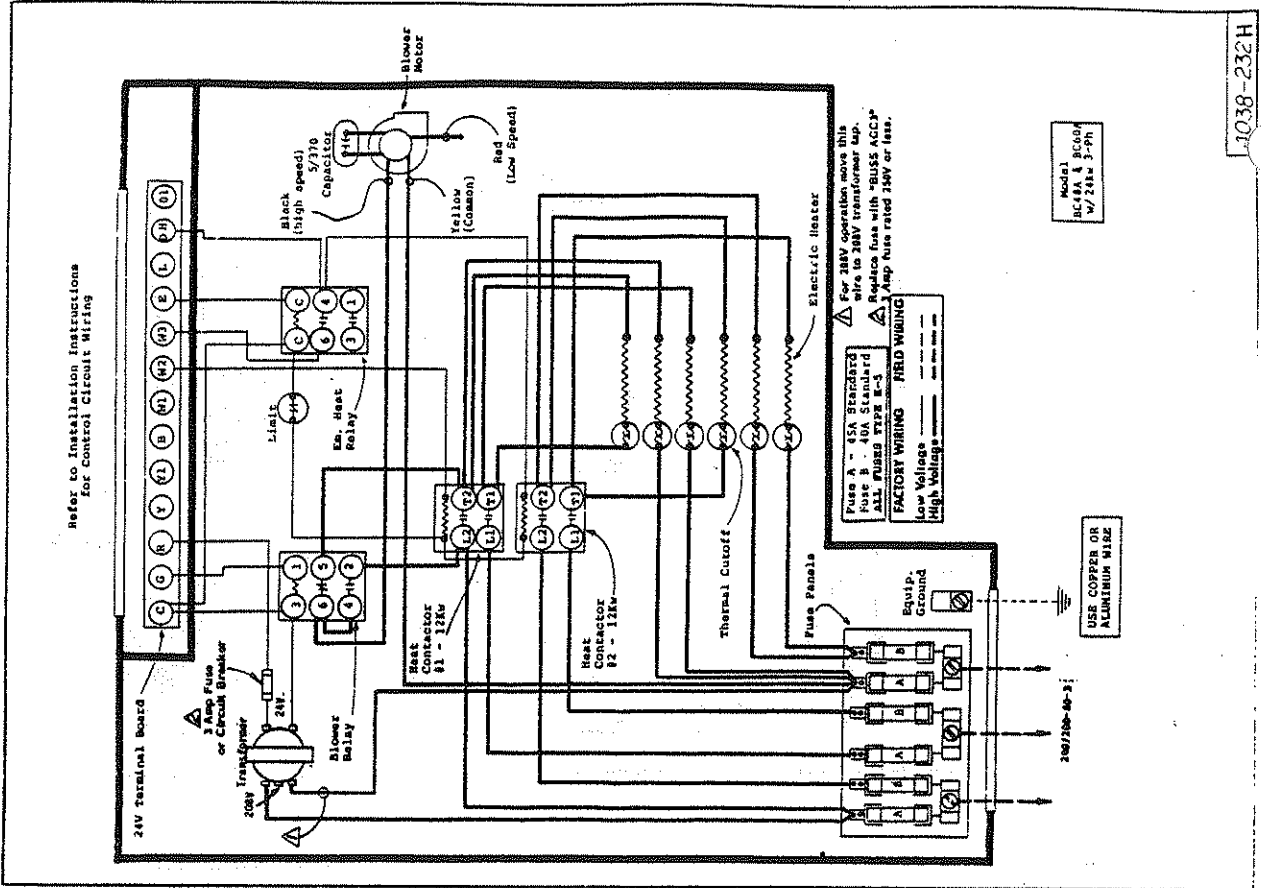

4038-232H

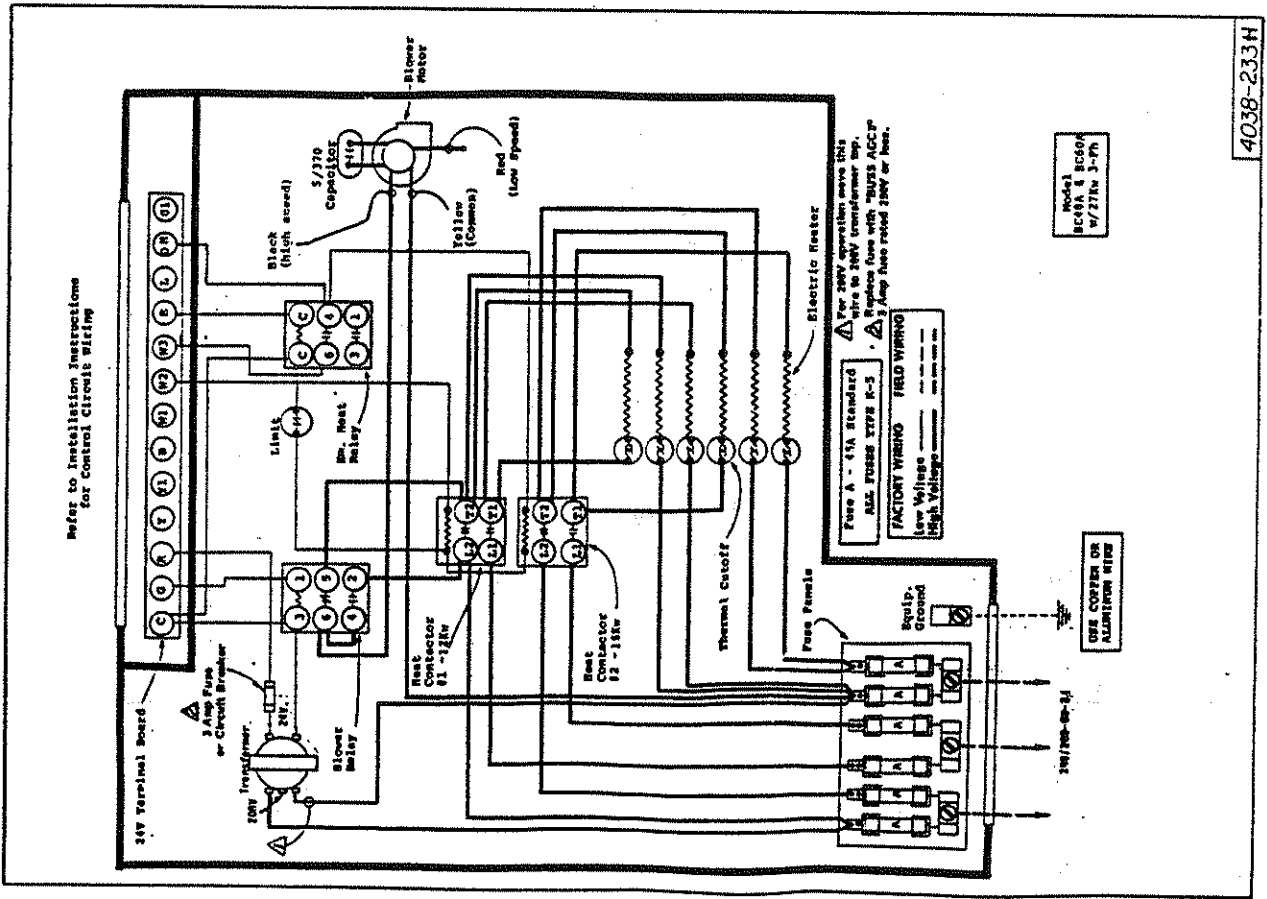

4038-233H

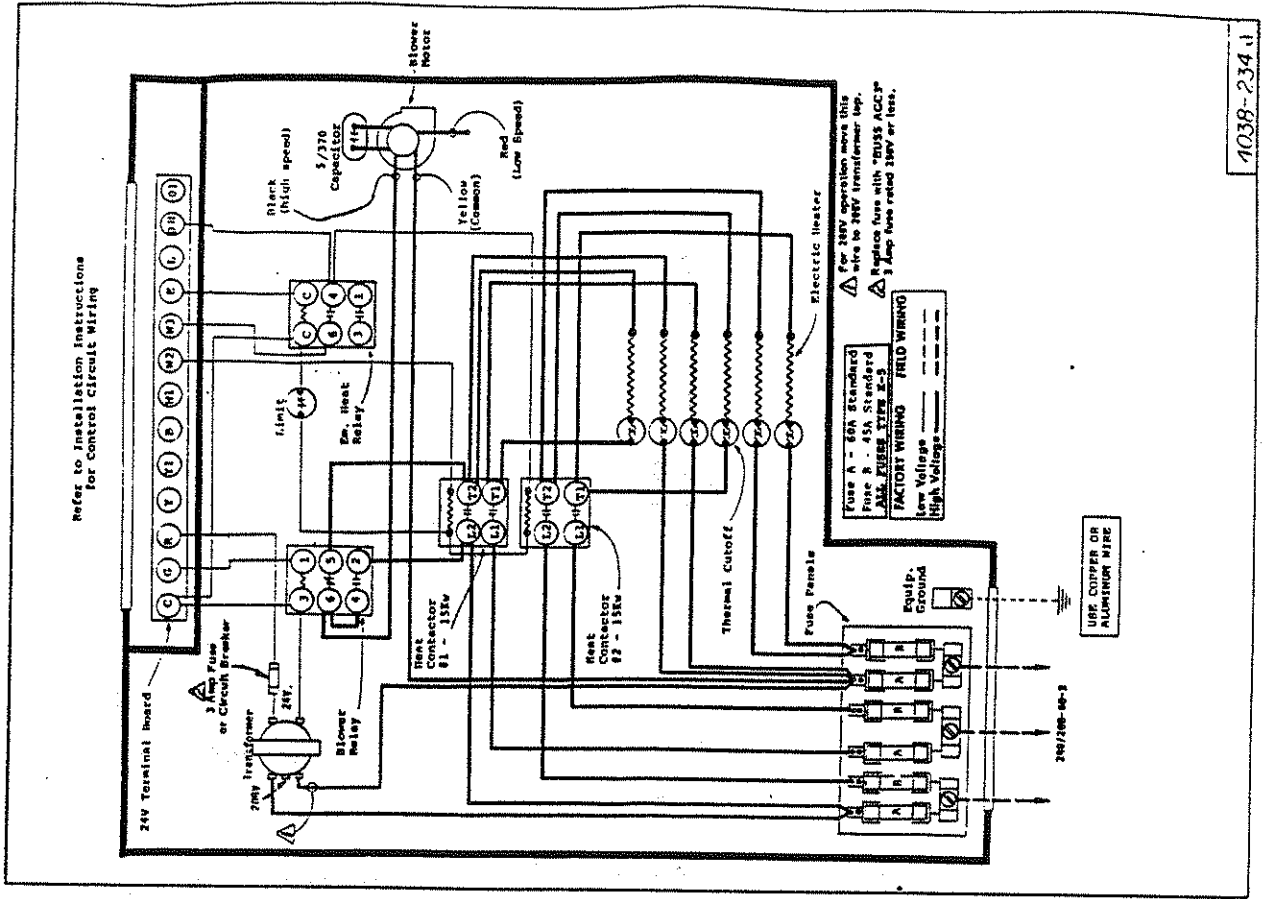

4038-234H

