

**SINGLE PACKAGE HEAT PUMP  
INSTALLATION INSTRUCTIONS**

**MODELS**

**PH42**

**PH48-2**

**PH60-4**

**FOR RESIDENTIAL AND COMMERCIAL  
HEATING / COOLING APPLICATIONS**

ELECTRICAL DATA

MODEL	Rated Volts & PH	Operating Voltage Range	Heater KW @ 240V	Max. Unit Amps	No. Field Power Circuits	Internal Fuses		Req'd Maximum External Fuses or Ckt. Breaker*		Minimum Circuit Ampacity		Field Power Wiring**		Ground Wire Size**
						Ckt. A	Ckt. B	Ckt. A	Ckt. B	Ckt. A	Ckt. B	Ckt. A	Ckt. B	Circuit A/B
PH24-1	230/208 1	197-253	0	17.5	1			30		21		10		10
			5	38.3	1			50		47		6		10
			10	59.1	2			50	30	47	26	6	10	10/10
PH31-1	230/208 1	197-253	0	20.4	1			35		26		10		10
			5	41.2	1			60		52		6		10
			10	62.0	2			60	30	52	26	6	10	10/10
			15	82.9	2	60	60	60	60	52	52	6	6	10/10
PH36-2	230/208 1	197-253	0	24.4	1			45		29		10		10
			5	45.2	1			60		55		6		10
			10	66.0	2			60	30	55	26	6	10	10/10
			15	86.9	2	60	60	60	60	55	52	6	6	10/10
PH36-2-3	230/208 3	187-253	0	19.4	1			35		24		10		10
			9	41.1	1			60		51		6		10
			15	55.6	2			35	45	24	45	10	6	10/10
PH36-2-3	460 3	414-506	0	9.7	1			15		15		14		14
			9	20.5	1			30		26		10		10
			15	27.7	1			35		35		8		10
PH42	230/208	197-253	0	28	1			50		35		8		10
			5	48.8	2			50	30	35	26	8	10	10/10
			10	69.6	2			50	60	35	52	8	6	10/10
			15	90.5	2	60	60/30	50	80	35	78	8	3	10/6
PH42-3	230/208 3	187-253	0	21	1			35		26		10		10
			9	42.7	1			60		53		6		10
			15	57.2	2			35	45	26	45	10	6	10/10
PH42-3	460 3	414-506	0	11	1			20		15		14		14
			9	21.8	1			30		27		10		10
			15	32.7	1			40		36		8		10
PH48-2	230/208 1	197-253	0	30	1			60		37		8		10
			5	50.8	2			60	30	37	26	8	10	10/10
			10	71.6	2			60	60	37	52	8	6	10/10
			15	92.5	2	60	60/30	60	80	37	78	8	3	10/6
			20	113.2	2	60	60/60	60	110	37	104	8	1	10/6
PH48-2-3	230/208 3	187-253	0	23	1			40		28		10		10
			9	42.7	2			40	30	28	27	10	10	10
			15	57.2	2			40	45	28	45	10	6	10/10
			18	64.4	2			40	60	28	54	10	6	10/10
PH48-2-3	460 3	414-506	0	12	1			15		15		14		14
			9	22.8	1			30		28		10		10
			15	30	1			40		37		8		10
			18	33.7	1			45		42		6		10
PH60-4	230/208 1	197-253	0	37.5	1			60		45		6		10
			5	58.3	2			60	30	45	26	6	10	10/10
			10	79.1	2			60	60	45	52	6	6	10/10
			15	100	2	60	60/30	60	80	45	78	6	3	10/6
			20	120.7	2	60	60/60	60	110	45	104	6	1	10/6
PH60-4-3	230/208 3	187-253	0	26.5	1			50		31		8		10
			9	48.2	2			50	30	31	27	8	10	10
			15	62.7	2			50	45	31	45	8	6	10/10
			18	69.9	2			50	60	31	54	8	6	10/10
PH60-4-3	460 3	414-506	0	13.3	1			25		16		12		14
			9	26.5	1			35		29		8		10
			15	35	1			40		38		6		10
			18	37.4	1			45		43		6		10

\*Maximum time delay fuse or HACR type circuit breaker.

\*\*Based on 60° Copper Wire.

## IMPORTANT

The equipment covered in this manual is to be installed by trained, experienced service and installation technicians. Any heat pump is more critical of proper operating charge and an adequate duct system than a straight air conditioning unit. All duct work, supply and return, must be properly sized for the design air flow requirement of the equipment. NESCA is an excellent guide to proper sizing. All duct work or portions thereof not in the conditioned space should be properly insulated in order to both conserve energy and prevent condensation or moisture damage.

## SHIPPING DAMAGE

Upon receipt of equipment, the carton should be checked for external signs of shipping damage. If damage is found, the receiving party must contact the last carrier immediately, preferably in writing, requesting inspection by the carrier's agent.

## GENERAL

The refrigerant system is completely assembled and charged. All internal wiring is complete.

The unit is designed for use with or without duct work. Flanges are provided for attaching the supply and return ducts.

These instructions explain the recommended method to install the air cooled self-contained unit and the electrical wiring connections to the unit.

These instructions and any instructions packaged with any separate equipment required to make up the entire air conditioning system should be carefully read before beginning the installation. Note particularly "Starting Procedure" and any tags and/or labels attached to the equipment.

While these instructions are intended as a general recommended guide, they do not supersede any national and/or local codes in any way. Authorities having jurisdiction should be consulted before the installation is made.

## LOCATION

**General** - The unit must be located outside, or in a well ventilated area. It must not be in the space being heated or cooled. A sound absorbing material should be considered if the unit is to be installed in such a position or location that might cause transmission of sound or vibration to the living area or adjacent buildings.

**Slab Mounting** - In areas where winter temperatures DO NOT go below 32°F for periods over twelve hours, the unit may be slab mounted at grade level. When installing unit at grade level, install on a concrete slab at least four inches above finished grade level. Slab should have a slope tolerance away from the building structure of at least 1/4 inch per foot, while being level from side to side. This will prevent ice buildup under the unit during defrost cycles. Place slab in a location where run-off water from higher ground will not collect around unit. See Figure 1.

A minimum of 18 inches should be provided between the coil inlet and any building surfaces. Provide at least four feet between coil outlet and any building wall, fences or other vertical structures. Provide a minimum of three feet clearance on the service access side of the unit. See Figure 2.

**Roof Mounting** - When a unit is installed in areas where low ambient temperatures or strong winter winds exist, it should be placed so prevailing winter winds are not in direct line with the heat pump coil. If this is not possible, a wind barrier should be constructed. Place barrier 24 inches from the coil inlet side of the unit and in the direction of prevailing winds. Size barrier at least the same height and width as the unit. This may also be necessary on ground level installations. See Figure 3.

**Winter Installation Below 32°F** - In areas where winter conditions go below 32°F for extended periods, the unit must be elevated above the mounting surface to prevent snowfall or defrost ice accumulation from interfering with the operation of the unit. A minimum of twelve inch elevation is recommended, while greater elevation may be required for areas of high snow accumulation. Poured concrete, steel framework, brick, cement block, etc., can be utilized to construct a suitable raised mounting platform. See Figure 4.

## TYPICAL INSTALLATIONS

- Roof-Mounted** - The unit is mounted on a sturdy base on the roof of the building. Return air to the unit is brought through a single return grille (grilles with built-in filters are best, since they enable easy access for filter changing). Return air ducts are attached to the lower section of the front panel. Supply air is brought from the unit to attic duct work or to a furred down hall. Supply air duct is attached to the top of the front panel. CAUTION: All outdoor duct work must be thoroughly insulated and weatherproofed. All attic duct work must be thoroughly insulated. Two inch thick insulation with suitable vapor barrier is recommended for both outdoor and attic runs. In rooftop installations, as in all installations, the heat pump must be level from side to side. However, the unit should have a pitch along the length to assure complete external drainage of precipitation and of defrost condensate.
- Crawl Space** - Duct work installed in crawl space must be well insulated and provided with a vapor barrier. In addition, the crawl space must be thoroughly ventilated and provided with a good vapor barrier as a ground cover. It is most desirable to install the unit outdoors, rather than inside the crawl space, so that it will be readily accessible for service. In addition, it is necessary to dispose of the condensate from the outdoor coil on the heating cycle, and this is virtually impossible with the unit installed inside the crawl space.
- Slab Mounted at Ground Level** - This type installation is ideal for homes with slab floor construction, where a roof-mounted unit is not desired. The supply and return duct work can be run through a furred closet space.
- Thru-The-Wall** - This type installation requires a suitable framework to be fabricated capable of withstanding the unit weight. Normally the unit will be installed so as to minimize supply and return duct work.
- Other Installations** - Many other installations are possible with the packaged heat pump. No matter what the installation, always consider the following facts:
  - Insure that the discharge air is not obstructed in any way so as to cause operation difficulties.
  - The indoor coil drain pan is equipped with a coupling that must be piped through a condensate drain trap to a suitable drain.
  - Always mount the unit in such a position that it may be easily reached for servicing and maintenance.
  - Insure that the unit is clear so that proper air flow over the outdoor coil will be maintained.

**IMPORTANT:** Model PH24-1 has a single fan motor driving both the indoor blower and outdoor fan. This type of unit is particularly sensitive to natural air currents during defrost and some type of wind barrier is recommended. See Figure 3.

RATED CFM AND EXTERNAL STATIC PRESSURE (ESP) WET COIL (COOLING)			
MODEL	RATED CFM	RATED ESP	RECOMMENDED AIR FLOW RANGE
PH24-1	825	.13	725 - 975 CFM
PH31-1	1075	.50	975 - 1185 CFM
PH36-2	1275	.23	1150 - 1400 CFM
PH42	1500	.30	1350 - 1650 CFM
PH48-2	1700	.20	1520 - 1765 CFM
PH60-4	1700	.20	1520 - 1765 CFM

**AIR FILTERS**

Air filters for the return air side of the system are not provided as part of the basic piece of equipment because of the various types of application for these models, and must be field supplied and installed as part of the final installation.

Prior thought should be given to return air location and placement of the air filter(s). The air filter(s) must be of adequate size and readily accessible to the operator of the equipment. Filters must be adequate in size and properly maintained for proper operation. If this is not done, excessive energy use, poor performance, and multiple service problems will result. IT IS IMPOSSIBLE TO OVERSIZE AIR FILTERS. Generous sizing will result in cleaner air and coils, as well as lower operating costs and extend the time between required changes. The following table shows minimum filter areas and recommended filter sizes. Actual filter sizes can vary with the installation due to single or multiple returns utilizing a filter/grille arrangement or being placed immediately ahead of the indoor coil face in the return air duct.

MODEL	MINIMUM FILTER AREAS	RECOMMENDED SIZE
PH24-1	336 sq.in. (2.34 sq.ft)	12x30-5/8x1
PH31-1, PH36-2	462 sq.in. (3.21 sq.ft)	15x30-5/8x1
PH42, PH48-2, PH60-4	608 sq.in] (4.62 sq.ft)	(2)16x20x1

NOTE: If Roof Hood Accessory is to be used, information on air filters may be found under that heading in this manual. Air filters are supplied as part of that package.

**WIRING - MAIN POWER**

Refer to the unit rating plate for wire sizing information and maximum fuse size. Each outdoor unit is marked with a "Minimum Circuit Ampacity." This means that the field wiring used must be sized to carry that amount of current. Depending on the installed Kw of electric heat, there may be two field power circuits required. If this is the case, the unit serial plate will so indicate. Some models are suitable only for connection with copper wire, while others can be wired with either copper or aluminum wire. Each unit and/or wiring diagram will be marked "Use Copper Conductors Only" or "Use Copper or Aluminum Conductors." These instructions MUST BE adhered to. Refer to the National Electrical Code for complete current carrying capacity data on the various insulation grades of wiring material.

The electrical specifications on page 2 lists fuse and wire sizes (60°F copper) for all models, including the most commonly used heater sizes. Also shown are the number of field power circuits required for the various models with heaters.

The unit rating plate lists a "Maximum Time Delay Fuse" or "HACR" Type Circuit Breaker that is to be used with the equipment. The correct size must be used for proper circuit protection and also to assure that there will be no nuisance tripping due to the momentary high starting current of the compressor

**WIRING - 24V CONTROL CIRCUIT**

Nine (9) wires should be run from thermostat subbase to the 24V terminal board in the unit. A nine conductor, 19 gauge copper, color-coded thermostat cable is recommended. The connection points are shown on most of the wiring diagrams and are also shown below.

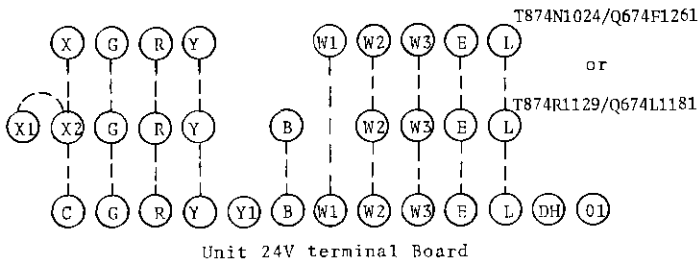

IMPORTANT NOTE: Only the thermostat and subbase combinations as shown above will work with this equipment. The stat and subbase MUST be matched, and correct operation can be assured only by proper selection and application of these parts.

**COMPRESSOR CUT-OFF THERMOSTAT AND OUTDOOR THERMOSTATS**

Heat pump compressor operation at outdoor temperatures below 0°F are neither desirable nor advantageous in terms of efficiency. Since most equipment at time of manufacture is not designated for any specific destination of the country, and most of the equipment is installed in areas not approaching the lower outdoor temperature range, the compressor cut-offs are not factory installed.

Outdoor thermostats are available to hold off various banks of electric heat until needed as determined by outdoor temperature. The set point of either type of thermostat is variable with geographic region and sizing of the heating equipment to the structure. Utilization of the Heating Application Data and the heat loss calculation of the building are useful in determining the correct set points.

**COMPRESSOR CUT-OFF & OUTDOOR THERMOSTAT WIRING**

See specific wiring information for the different models, heater Kw's, and voltages on page 5.

**WALL THERMOSTAT AND SUBBASE COMBINATIONS**

Group	Thermostat	Subbase	Predominant Feature
A	8403-017 (T874R1129)	8404-009 (Q674L1181)	Heat or Cool No Auto $\Delta$
B	8403-018 (T874N1024)	8404-010 (Q674F1261)	Automatic Heat-Cool Changeover Position $\Delta$

- $\Delta$  No automatic changeover position--must manually place in heat or cool. Reversing valve remains energized at all times system switch is in heat position (except during defrost cycle). No pressure equalization noise when thermostat is satisfied on either heating or cooling.
- $\Delta$  Allows thermostat to control both heating and cooling operation when set in "AUTO" position. Reversing valve de-energizes at end of each "ON" heating cycle.

IMPORTANT NOTE: Both thermostat and sub-base combinations shown above incorporate the following features: Man-Auto fan switch, Off-Heat-Cool-Em. Heat Switch, and two (2) indicator lamps--one for Emergency Heat and one for compressor malfunction.

**THERMOSTAT INDICATOR LAMPS**

The red lamp marked "EM.HT." comes on and stays on whenever the system switch is placed in the Em. Ht. position. The green lamp marked "check" will come on if there is any problem that prevents the compressor from running when it is supposed to be.

**EMERGENCY HEAT POSITION**

The operator of the equipment must manually place the system switch in this position. This is done when there is a known problem with the outdoor section, or when the green "check" lamp comes on indicating a problem.

**COMPRESSOR MALFUNCTION RELAY (Single Phase Models Only)**

Actuation of the green "check" lamp is accomplished by a voltage type relay which is factory installed. Any condition such as loss of charge, defective capacitor, defective contactor, etc., that will prevent compressor from operating will cause green lamp to activate. This is a signal to the operator of the equipment to place system in emergency heat position.

**PRESSURE SERVICE PORTS**

High and low pressure service ports are installed on all units so that the system operating pressures can be observed. Pressure curves can be found later in the manual covering all models on both cooling and heating cycles. It is imperative to match the correct pressure curve to the unit by model number.

## SEQUENCE OF OPERATION

**Cooling** - Circuit R-Y makes at thermostat pulling in compressor contactor starting the compressor and outdoor motor. The G (indoor motor) circuit is automatically completed on any call for cooling operation, or can be energized by manual fan switch on subbase for constant air circulation.

**Heating** - A 24V solenoid coil on reversing valve controls heating cycle operation. Two thermostat options, one allowing "Auto" changeover from cycle to cycle and the other constantly energizing solenoid coil during heating season and thus eliminating pressure equalization noise except during defrost, are to be used. On "Auto" option, a circuit is completed from R-W1 and R-Y on each heating "on" cycle, energizing reversing valve solenoid and pulling in compressor contactor starting compressor and outdoor motor. R-G also make starting indoor blower motor. Heat pump heating cycle now in operation. The second option has no "Auto" changeover position, but instead energizes the reversing valve solenoid constantly whenever the system switch on subbase is placed in "Heat" position, the "B" terminal being constantly energized from R. A thermostat demand for heat completes R-Y circuit, pulling in compressor contactor starting compressor and outdoor motor. R-G also make starting indoor blower motor.

## DEFROST CYCLE

The defrost cycle is controlled by time and temperature. The 240 volt timer motor runs all the time the compressor is in operation. When the outdoor temperature is in the lower 40°F temperature range or colder, the outdoor coil temperature is 32°F or below. This temperature is sensed by the defrost thermostat mounted near the bottom of the outdoor coil on a return bend. The defrost thermostat closes at approximately 32°F. Every 60 (or 30) minutes that the compressor is running, contacts 3-5 close for 7 minutes, with contacts 3-4 closed for the first 40 seconds of that 7 minutes. If the defrost thermostat is closed, the defrost relay energizes and places the system in defrost mode. An interlocking circuit is created with timer contact 3-5 and defrost relay contact 7-9 in series.

During the defrost mode, the refrigerant cycle switches back to the cooling cycle, the outdoor motor stops, electric heaters are energized, and hot gas passing through the outdoor coil melts any accumulated frost. When the temperature rises to approximately 57 F (Model PH24-1 is 42°F), the defrost thermostat opens, de-energizing the defrost relay and returning the system to heating operation.

If some abnormal or temporary condition such as a high wind causes the heat pump to have a prolonged defrost cycle, contacts 3-5 of the defrost timer will open after 7 minutes and restore the system to heating operations automatically.

There are two time settings on the defrost timer-- 30 minutes and 60 minutes. Most models are shipped wired on the 60 minute setting for greatest operating economy. If special circumstances require a change to the shorter time, remove wire connected to terminal 5/60 and reconnect to terminal 5/30.

**NOTE:** Model PH24-1 has single motor which stops during defrost cycle. There is also an interlock relay which prevents any electric heat from being on during the defrost period when there is no air flow across the indoor coil.

There is a manual advance knob located on the timer. This can be used to advance timer to contact closure point if it is desired to check out defrost cycle operation, without waiting for time to elapse.

## DEFROST TIMER WIRING

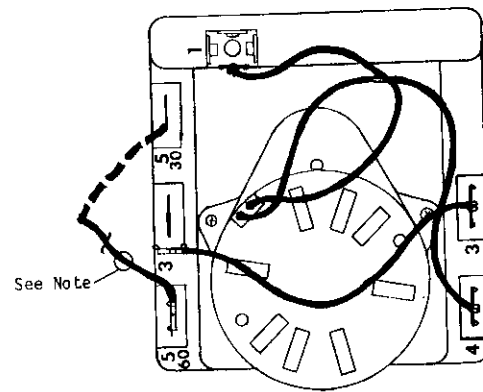

**NOTE:** All models except PH24-1 are connected to 5 60 terminal (60 minute). Ph24-1 is connected to 5 30 terminal (30 minutes) as shown by dotted line. Any model can be changed from 60 minutes to 30 minutes by unplugging from 5 60 terminal and reconnecting to 5 30 terminal.

## SERVICE HINTS

1. Caution homeowner to maintain clean air filters at all times. Also, not to needlessly close off supply and return air registers. This reduces air flow through the system, which shortens equipment service life as well as increasing operating costs.
2. Switching to heating cycle at 75°F or higher outside temperature may cause a nuisance trip of the manual reset high pressure switch.
3. The heat pump wall thermostats perform multiple functions. Be sure that all function switches are correctly set for the desired operating mode before trying to diagnose any reported service problems.
4. Check all power fuses or circuit breakers to be sure that they are the correct rating.
5. Periodic cleaning of the outdoor coil to permit full and unrestricted airflow circulation is essential.

## IMPORTANT INSTALLER NOTES:

1. For improved start-up performance wash the indoor coil with a dishwasher detergent.

## REFRIGERANT CHARGE

The correct system R-22 charge is shown on the unit rating plate. Optimum unit performance will occur with a refrigerant charge resulting in a suction line temperature (6" from compressor) as shown in the following table:

Model	Rated Airflow	95°F OD Temp	82°F OD Temp.
PH24-1	825	60 - 62	68 - 70
PH31-1	1075	55 - 57	65 - 67
PH36-2	1275	53 - 55	66 - 68
PH42	1500	60 - 62	67 - 69
PH48-2	1700	56 - 58	60 - 62
PH60-4	1700	59 - 61	64 - 66

The above suction line temperatures are based upon 80°F dry bulb/67°F wet bulb (50% R.H.) temperature and rated airflow across the evaporator during cooling cycle.

**CRANKCASE HEATERS**

All units are provided with some form of compressor crankcase heat. Some single phase units utilize the compressor motor start winding in series with a portion of the run capacitor to generate heat within the compressor shell to prevent liquid refrigerant migration.

Some three phase units utilize a wraparound type of crankcase heater that warms the compressor oil from the outside.

Some single and three phase models have an insertion well-type heater located in the lower section of the compressor housing. This is a self-regulating type heater that draws only enough power to maintain the compressor at a safe temperature.

Some form of crankcase heat is essential to prevent liquid refrigerant from migrating to the compressor, causing oil pump out on compressor start-up and possible valve failure due to compressing a liquid.

Refer to unit wiring diagram to find exact type of crankcase heater used.

The following decal is affixed to all outdoor units detailing start-up procedure. This is very important. Please read carefully.

**COMPRESSOR CUT-OFF WIRING**

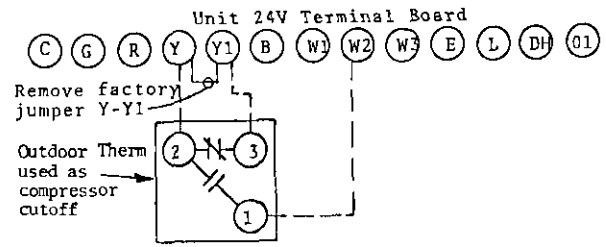

MODEL	KW	VOLTS	PHASE
PH24-1	0,5,10	230	1
PH31-1	0,5,10	230	1
PH36-2	0,5,10	230	1
PH36-2	0,6,9,12,15	230,460	3
PH42	0,5,10	230	1
PH42-3	0,9,12,15	230,460	3
PH48-2	0,5,10	230	1
PH48-2-3	0,9,12,15	230,460	3
PH60-4	0,5,10	230	1
PH60-4-3	0,9,12,15	230,460	3

**IMPORTANT**

**THESE PROCEDURES MUST BE FOLLOWED AT INITIAL START-UP AND AT ANY TIME POWER HAS BEEN REMOVED FOR 12 HOURS OR LONGER.**

TO PREVENT COMPRESSOR DAMAGE WHICH MAY RESULT FROM THE PRESENCE OF LIQUID REFRIGERANT IN THE COMPRESSOR CRANKCASE

1. MAKE CERTAIN THE ROOM THERMOSTAT IS IN THE "OFF" POSITION (THE COMPRESSOR IS NOT TO OPERATE).
2. APPLY POWER BY CLOSING THE SYSTEM DISCONNECT SWITCH THIS ENERGIZES THE COMPRESSOR HEATER WHICH EVAPORATES THE LIQUID REFRIGERANT IN THE CRANKCASE
3. ALLOW 4 HOURS OR 60 MINUTES PER POUND OF REFRIGERANT IN THE SYSTEM AS NOTED ON THE UNIT RATING PLATE, WHICHEVER IS GREATER
4. AFTER PROPERLY ELAPSED TIME THE THERMOSTAT MAY BE SET TO OPERATE THE COMPRESSOR.
5. EXCEPT AS REQUIRED FOR SAFETY WHILE SERVICING -- DO NOT OPEN SYSTEM DISCONNECT SWITCH.

7961-081

**COMPRESSOR CUT-OFF AND OUTDOOR THERMOSTAT WIRING**

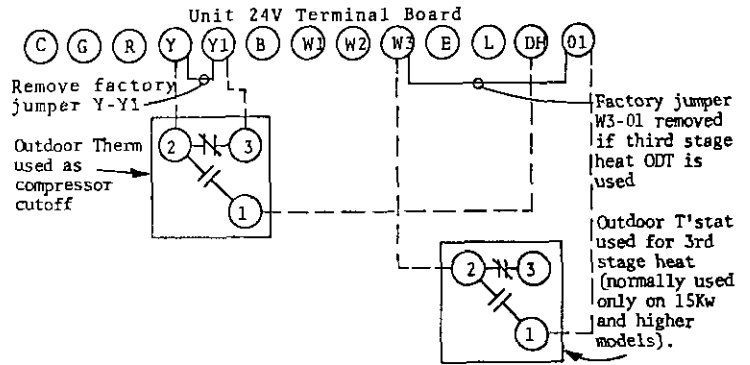

MODEL	KW	VOLTS	PHASE
PH31-1	15	230	1
PH36-2	15	230	1
PH42	15,20	230	1
PH48-2	15,20	230	1
PH48-2-3	18	230,460	3
PH60-4	15,20	230	1
PH60-4-3	18	230,460	3

Figure 1 -

**SLAB MOUNTING AT GROUND LEVEL**  
(Above 32°F Outside Temperature)

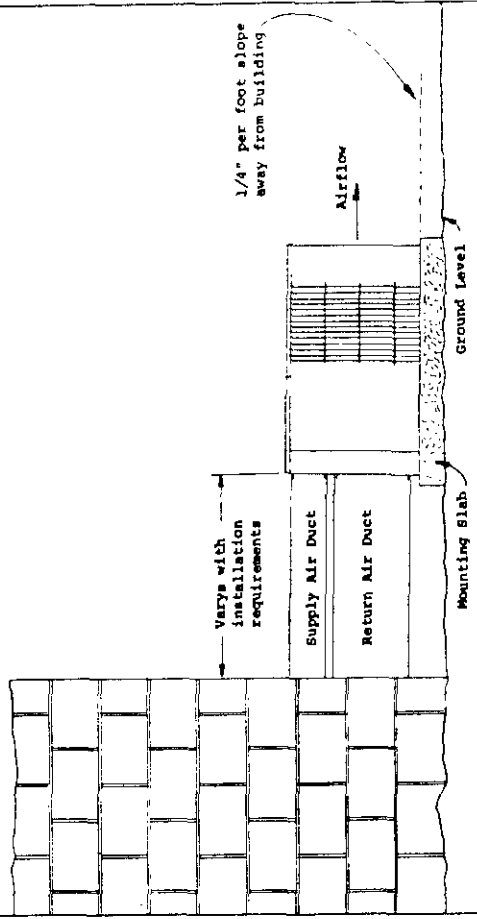

Figure 2

**AIRFLOW AND SERVICE ACCESS CLEARANCES**

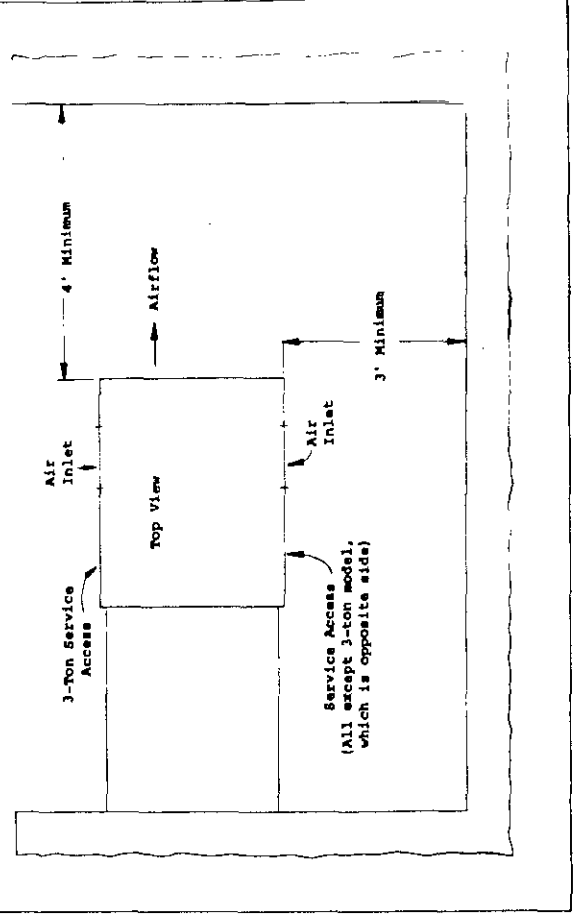
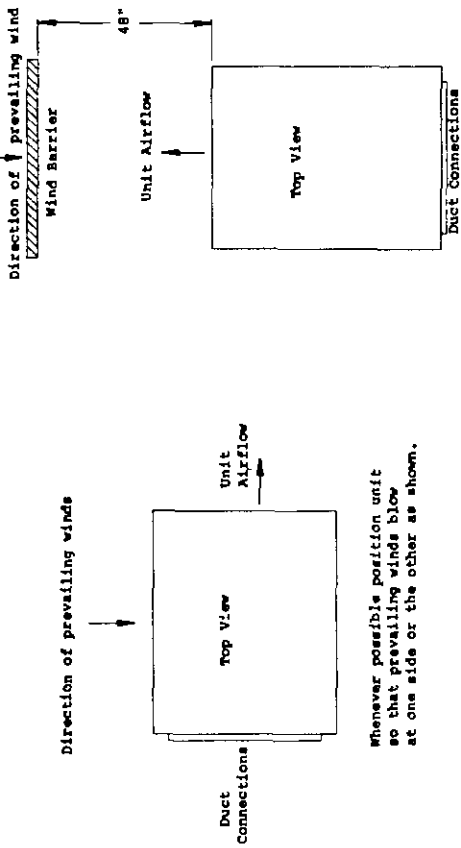

Figure 3

**ROOFTOP APPLICATION**

(May also be required for ground level installations!)



If outdoor coil must face prevailing wind, construct a wind barrier to assure proper defrost.

Figure 4

**ELEVATED MOUNTING PLATFORMS**

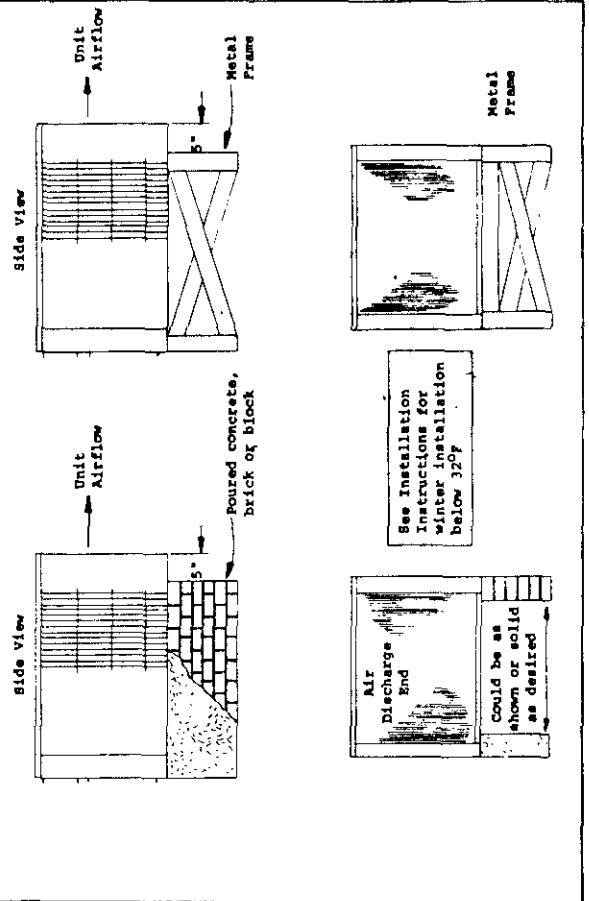

## PRE-FABRICATED ROOF CURB SPECIFICATIONS

HEAVY GAUGE GALVANIZED WITH WOOD NAILING STRIP, WELDED/LEAKPROOF  
ONE PIECE CONSTRUCTION-READY TO INSTALL. F.O.B. ADDISON, ILLINOIS

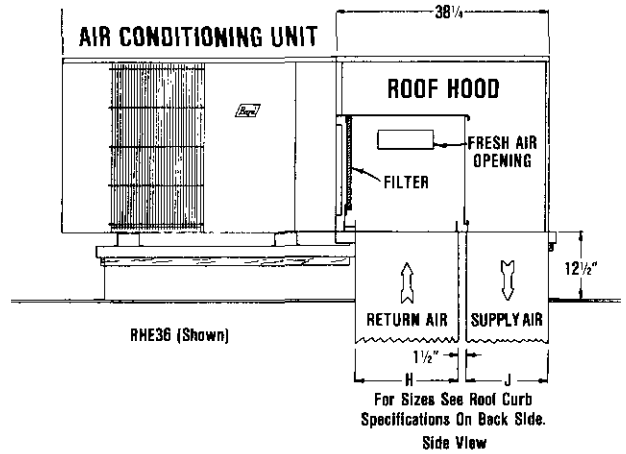
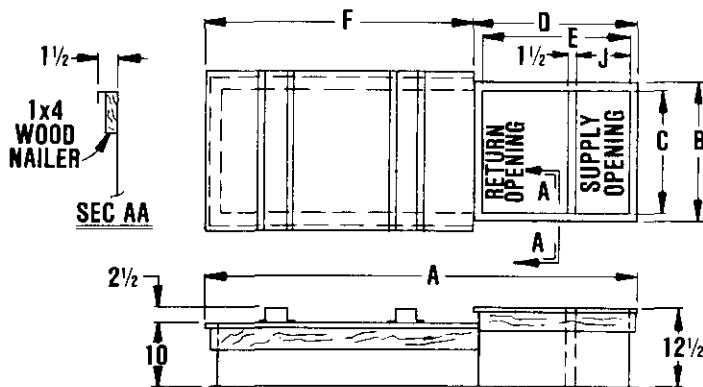

CURB AND ROOF HOOD DETAILS

	A	B	C*	D	E	F	J*	H*	ROOF HOOD MODEL	HEAT PUMP AND AIR CONDITIONING UNITS
P24 Curb	78-3/8	34-1/8	31-1/8	38-3/8	35-3/8	40	14-3/4	19-1/8	RHE24	P24A2, PH24-1
P36 Curb	80-3/8	40-1/4	37-1/4	38-3/8	35-3/8	42	14-3/4	19-1/8	RHE36	P31A, PH31-1, P36A4, PH36-2
P60 Curb	88-3/8	44-1/8	41-1/8	38-3/8	35-3/8	50	14-3/4	19-1/8	RHE60	PH42, P48A4, PH48-2, P60A4, PH60-4

**\*DUCT SIZING INFORMATION**

Return Air Dimension "C" is length  
Dimension "H" is width

Supply Air Dimension "C" is length  
Dimension "J" is width

### FIELD FABRICATED CURBING

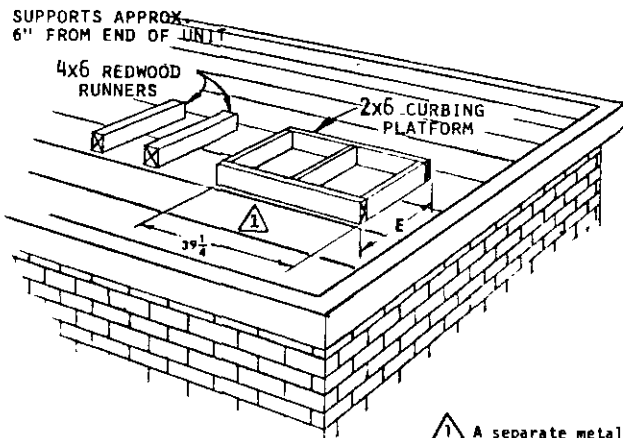

**⚠** A separate metal flashing should be installed around wood curbing. Caulk and seal all joints and weather-proof.

ROOF HOOD MODEL	UNIT MODEL	E
RHE24	P24A2 PH24-1	34-7/8
RHE36	P31A PH31-1 P36A4 PH36-2	41
RHE60	PH42 P48A4 PH48-2 P60A4 PH60-4	44-7/8

CURBING DETAILS (FIELD FABRICATED)



PACKAGED HEAT PUMP MODEL PH60-4

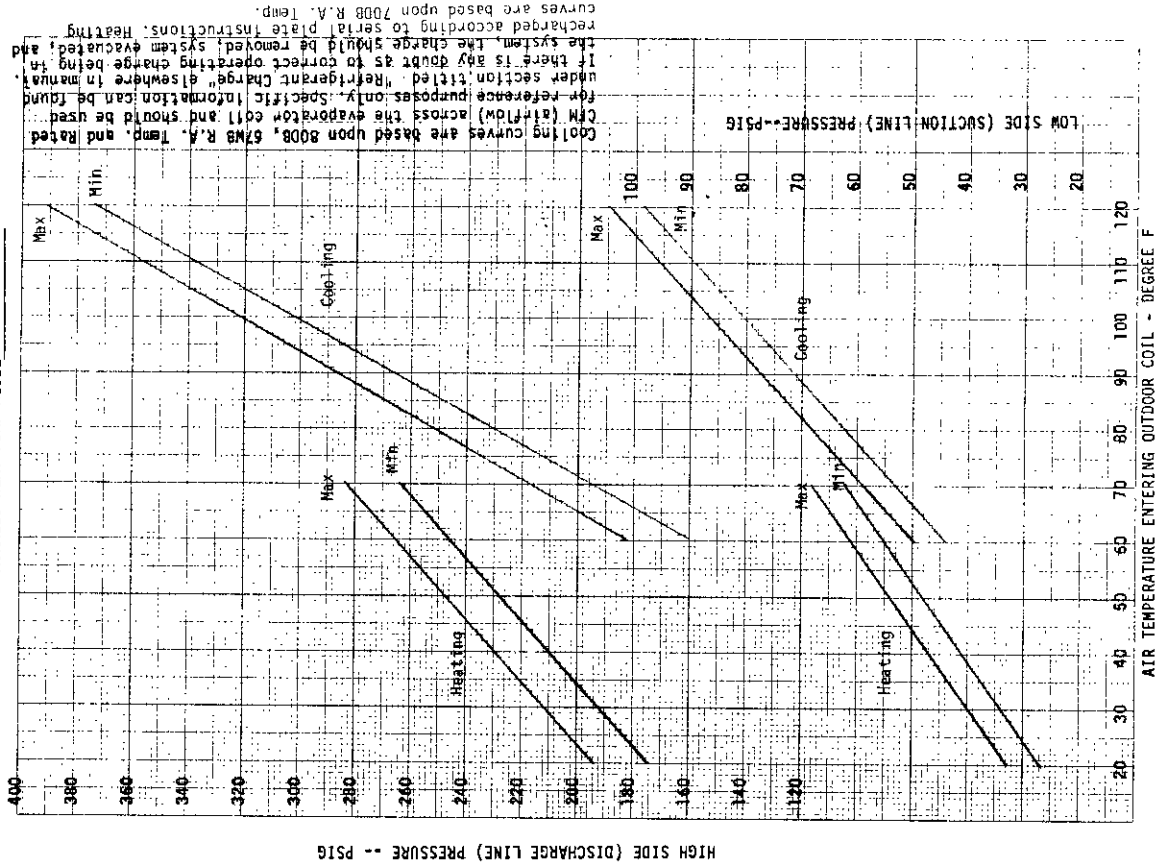

PACKAGED HEAT PUMP MODEL PH42 and PH48-2

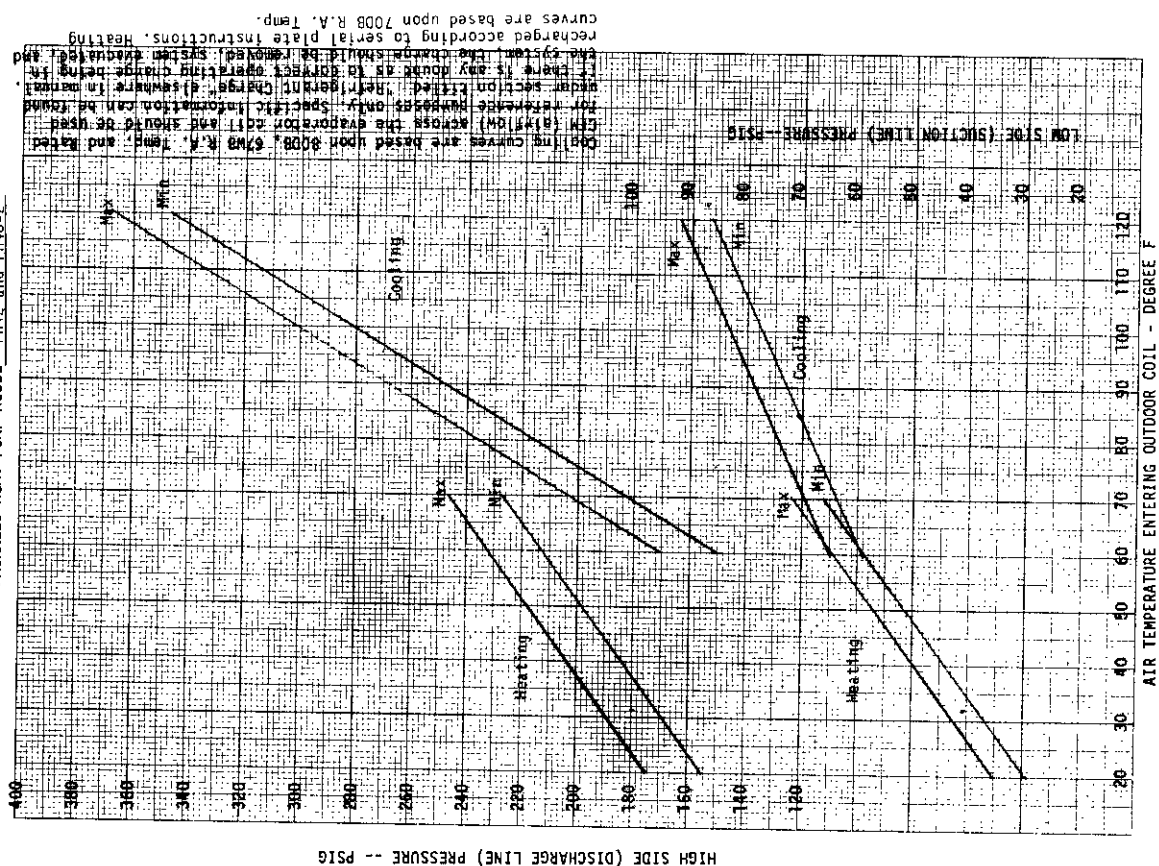

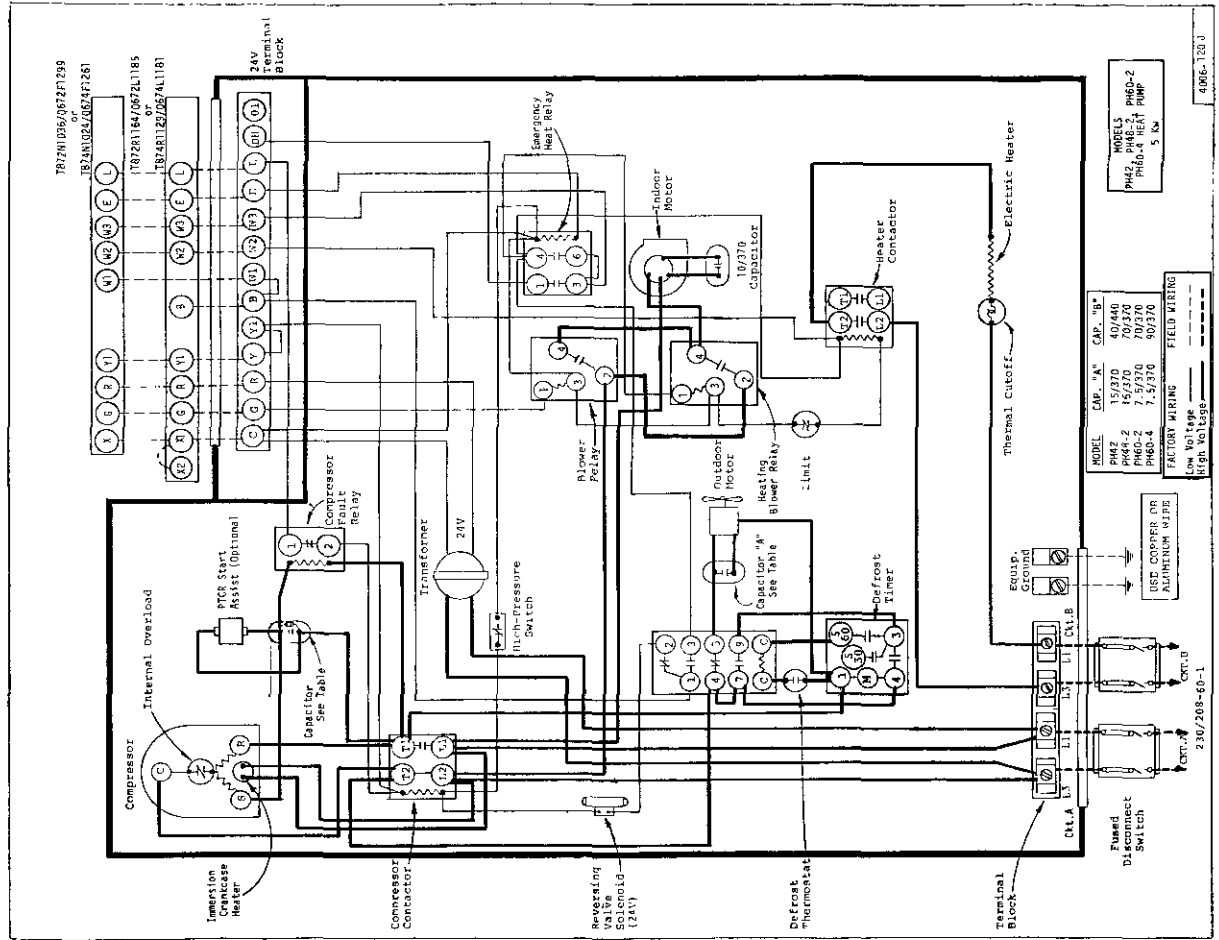
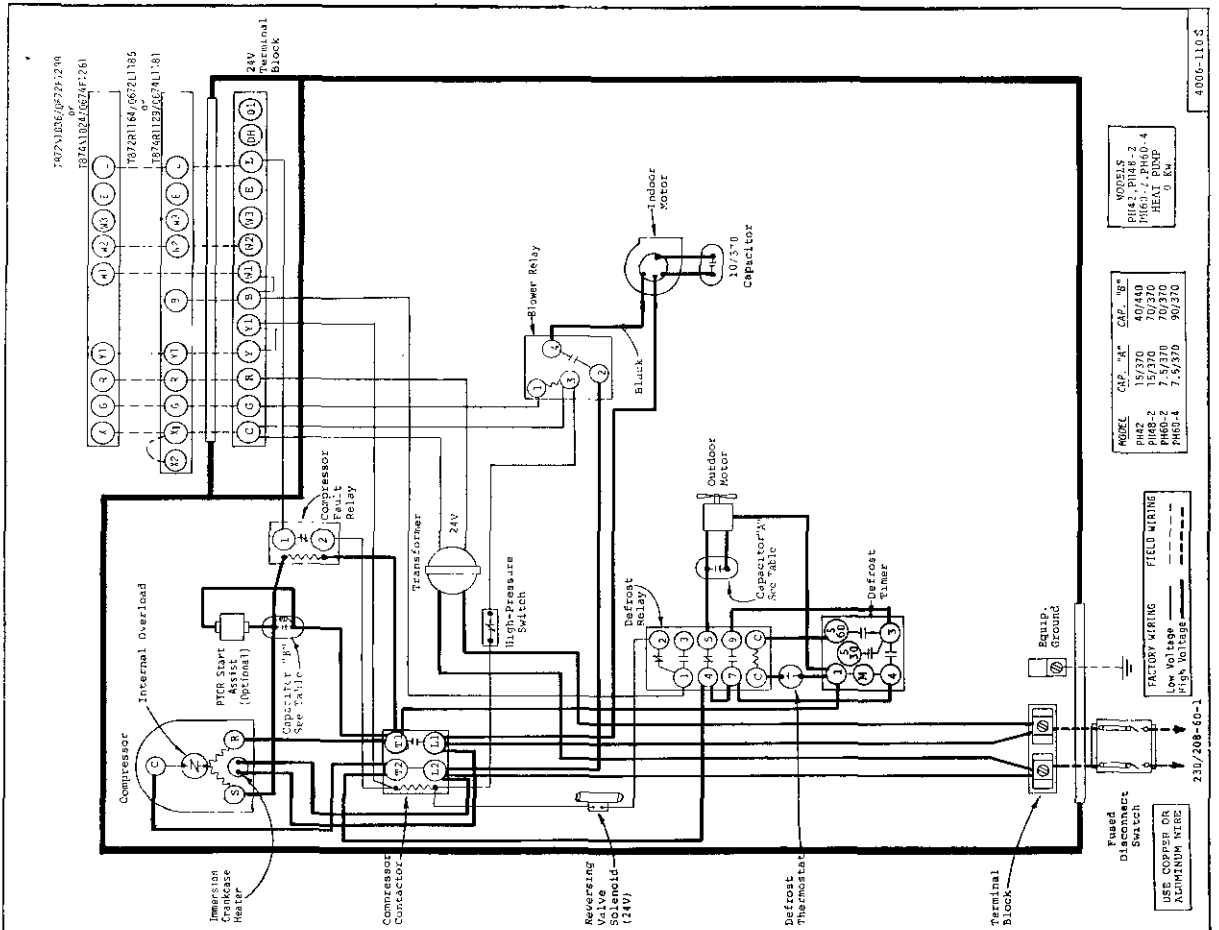





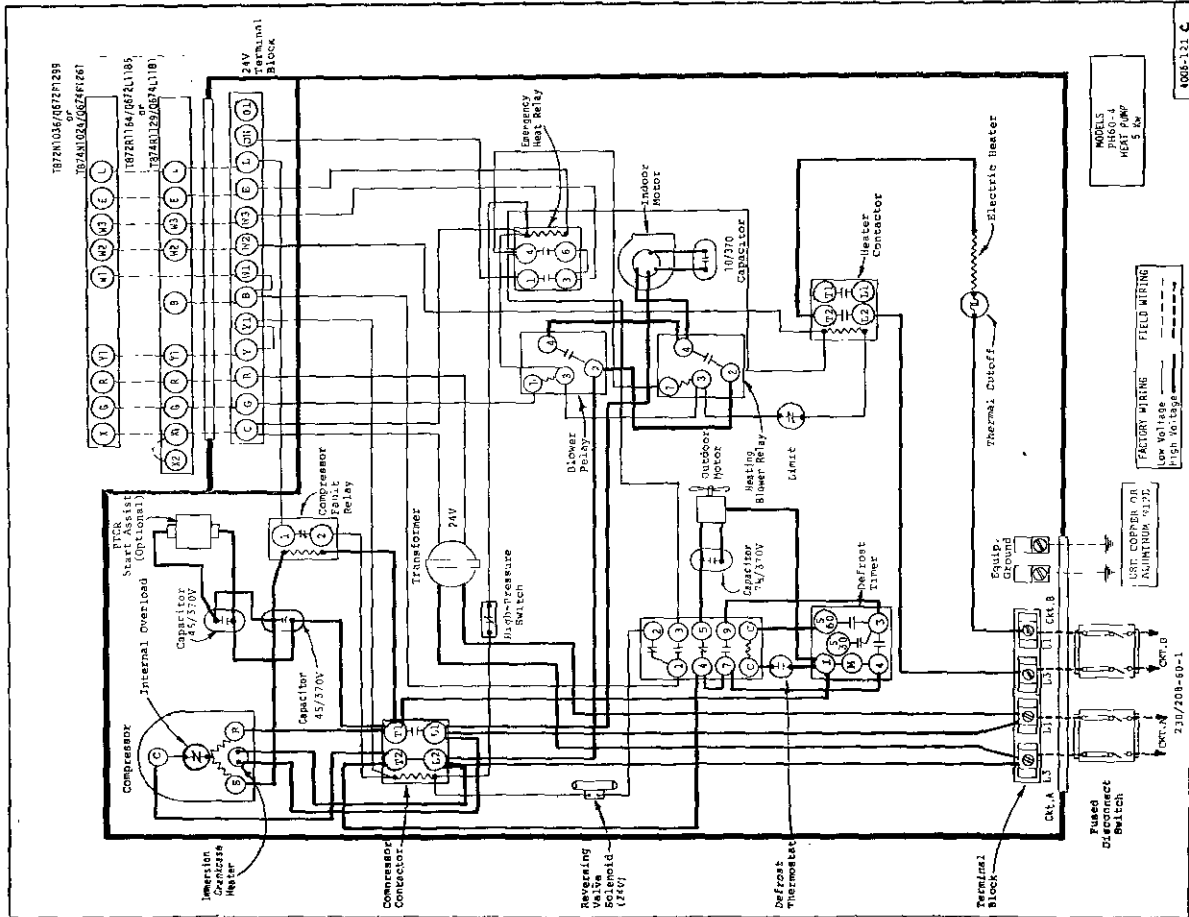
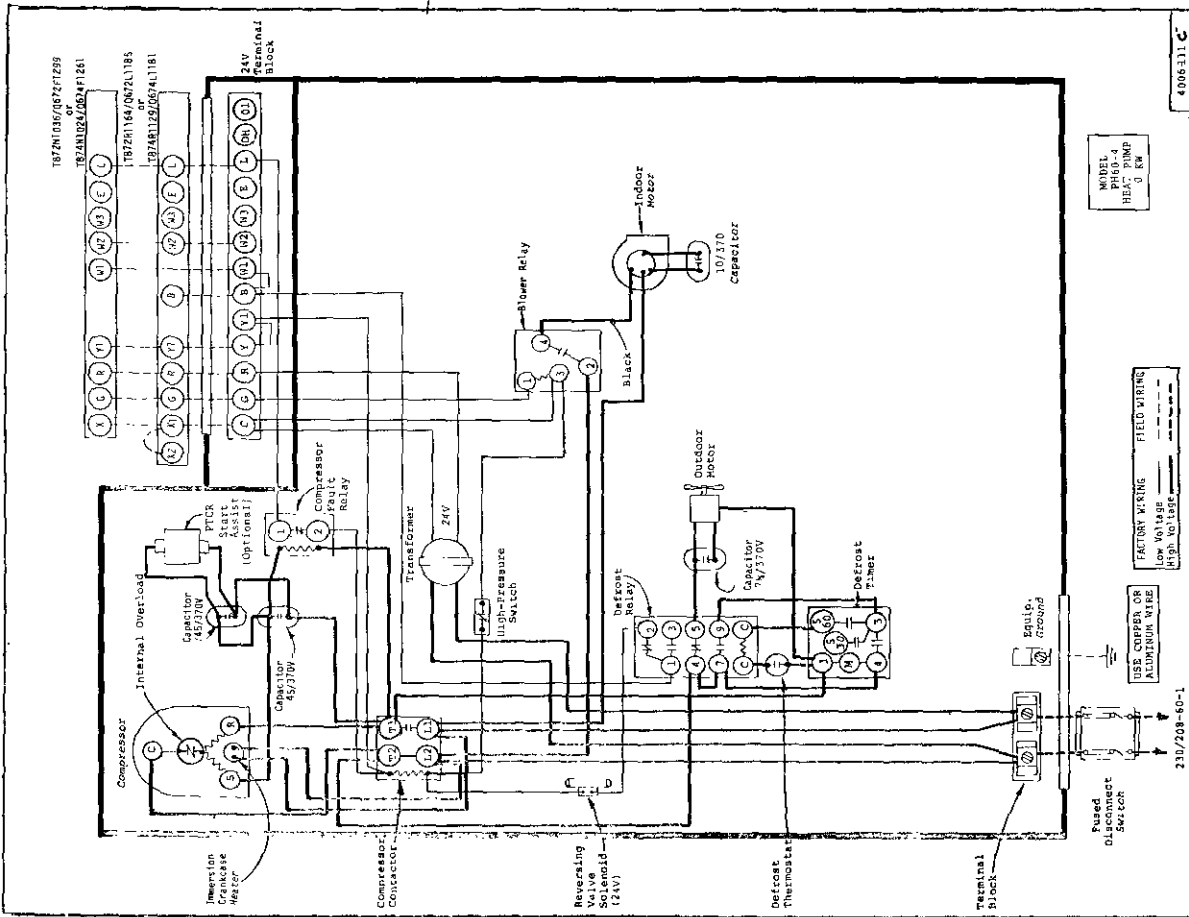

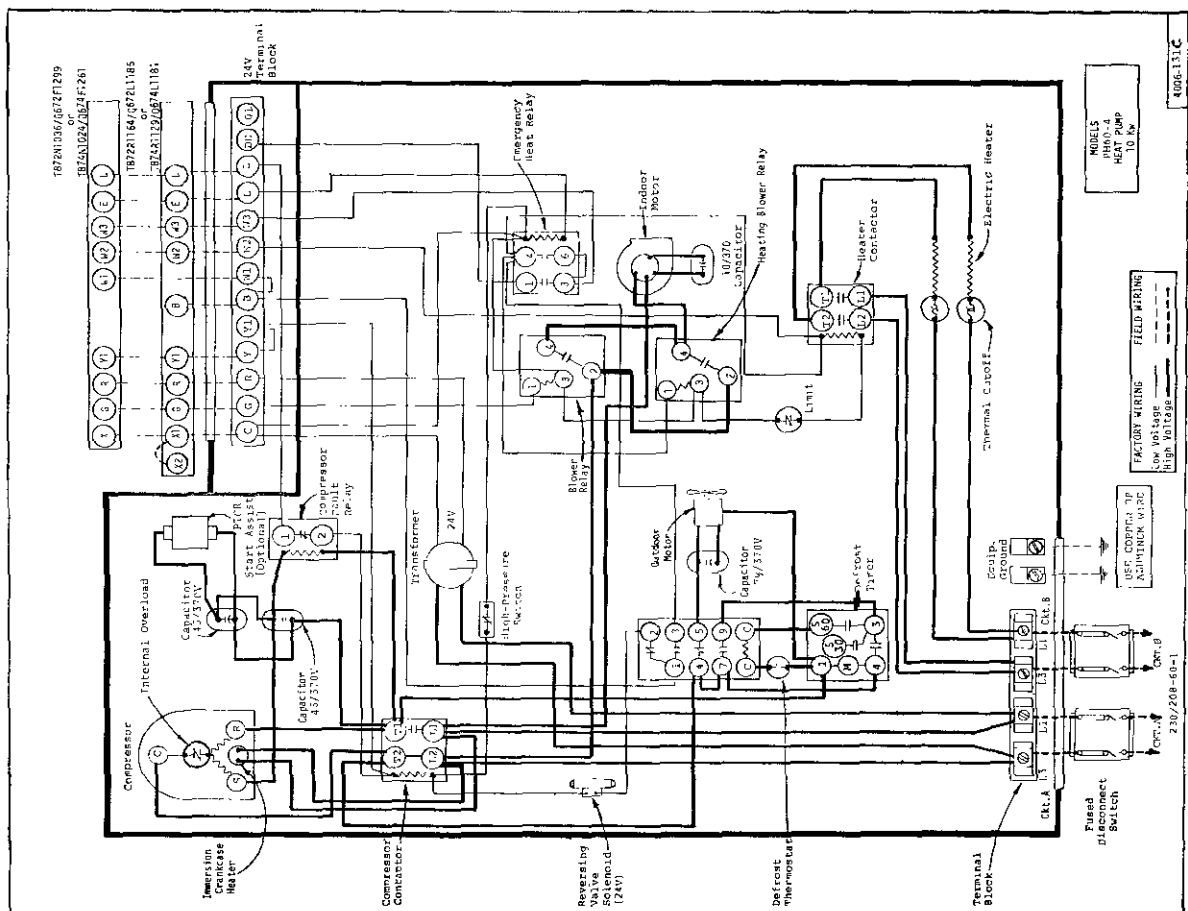
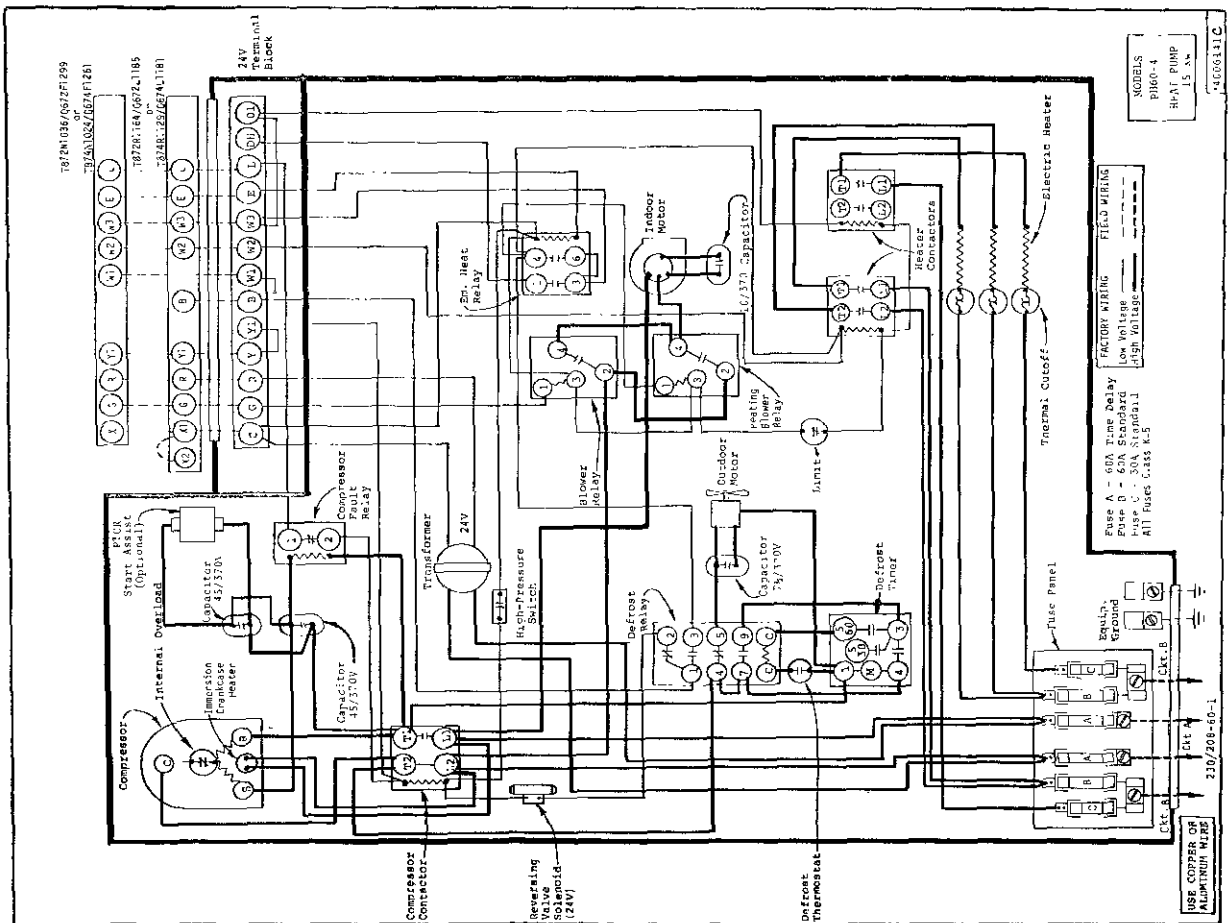

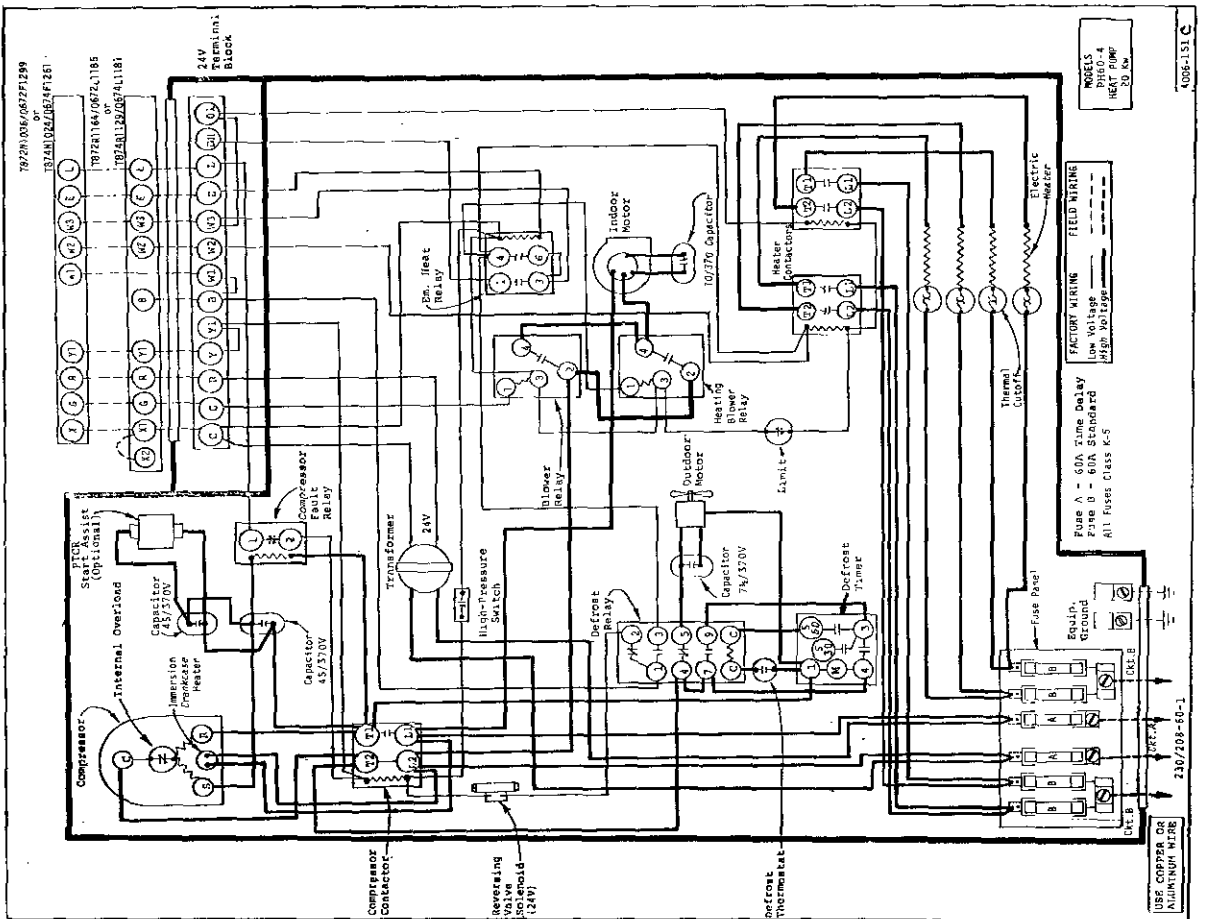
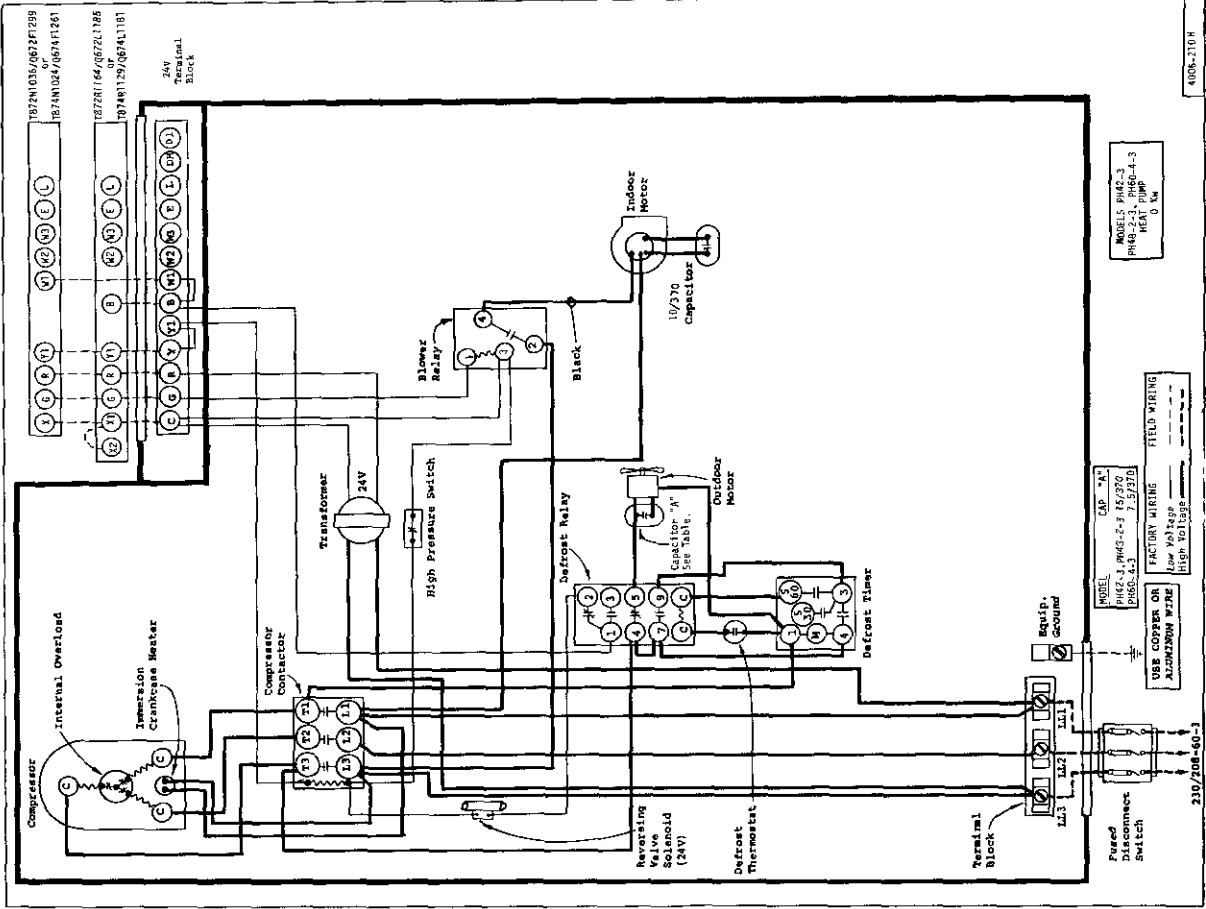

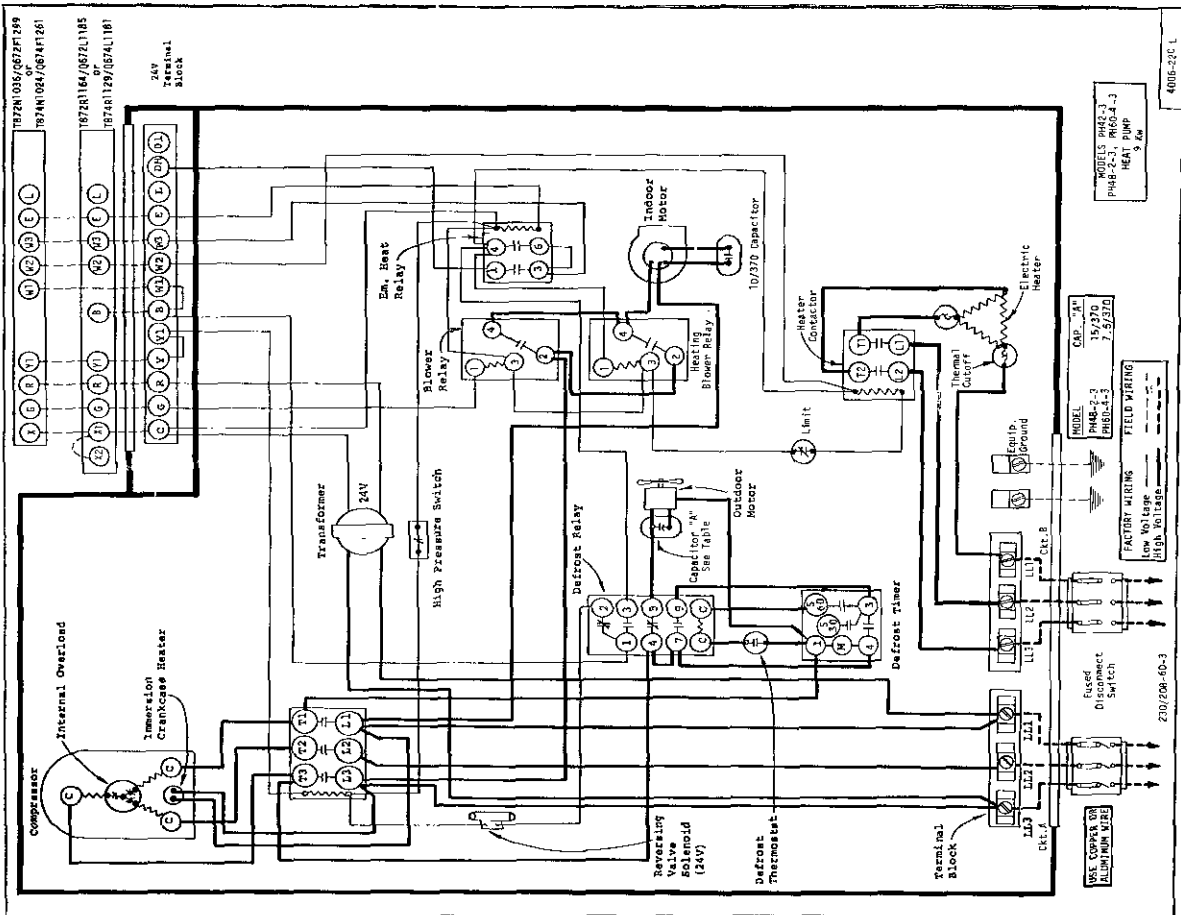
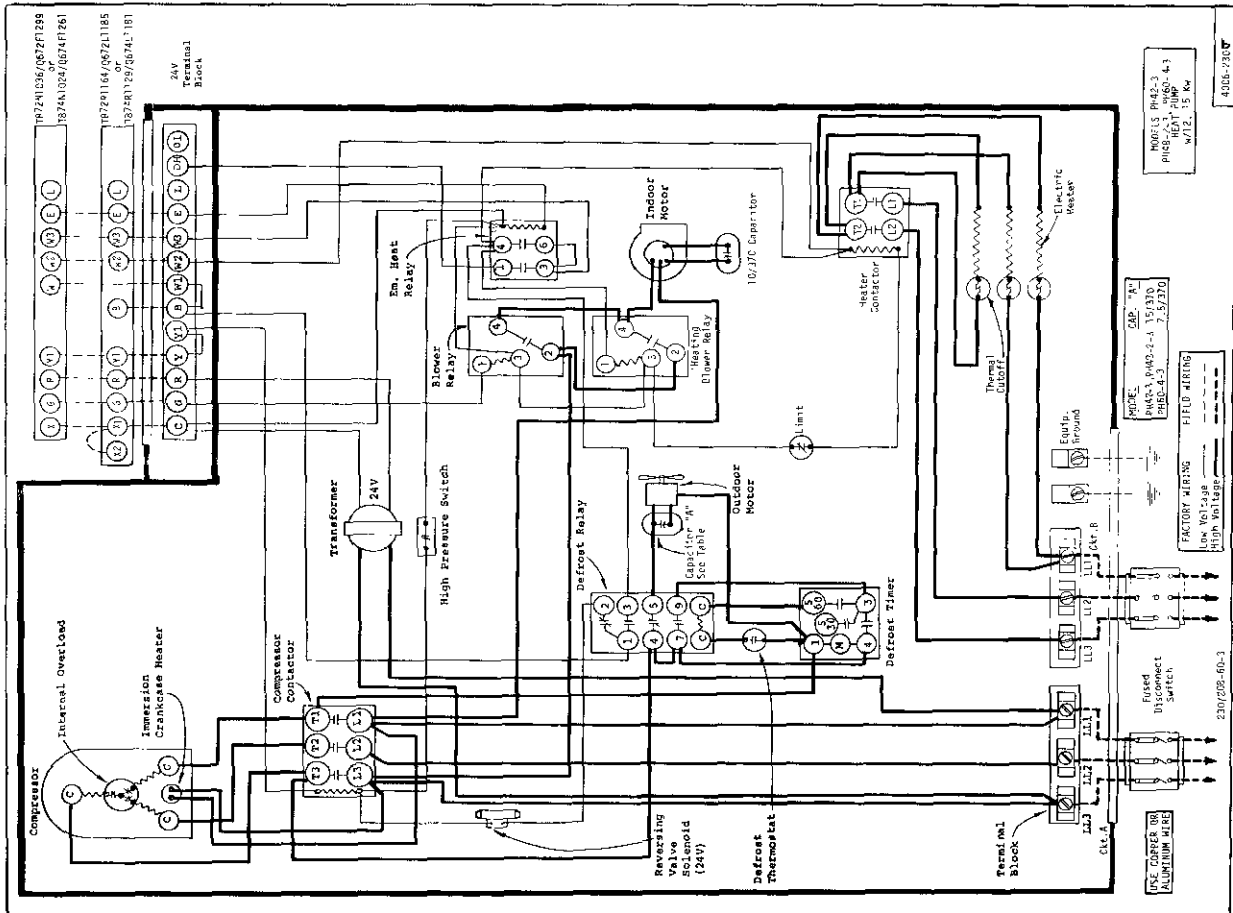



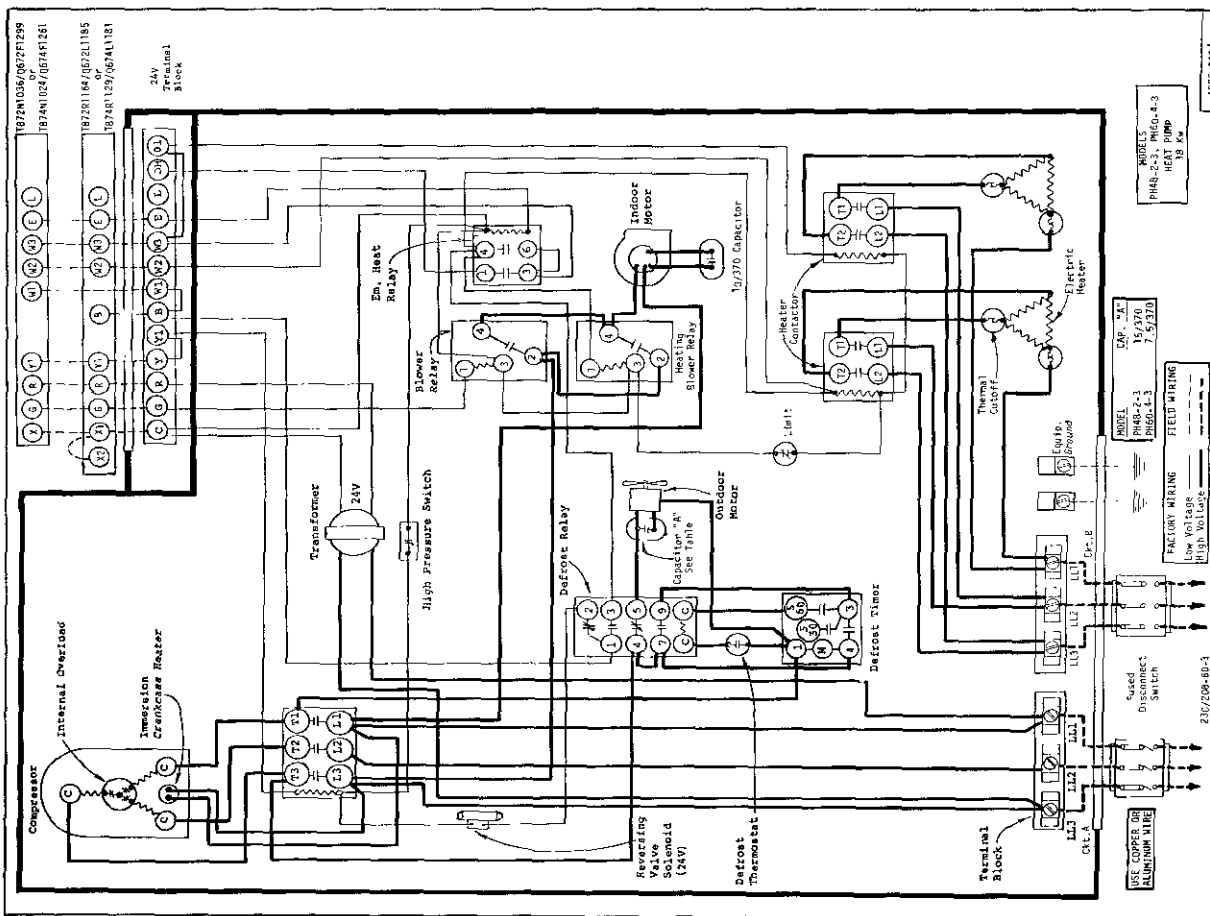
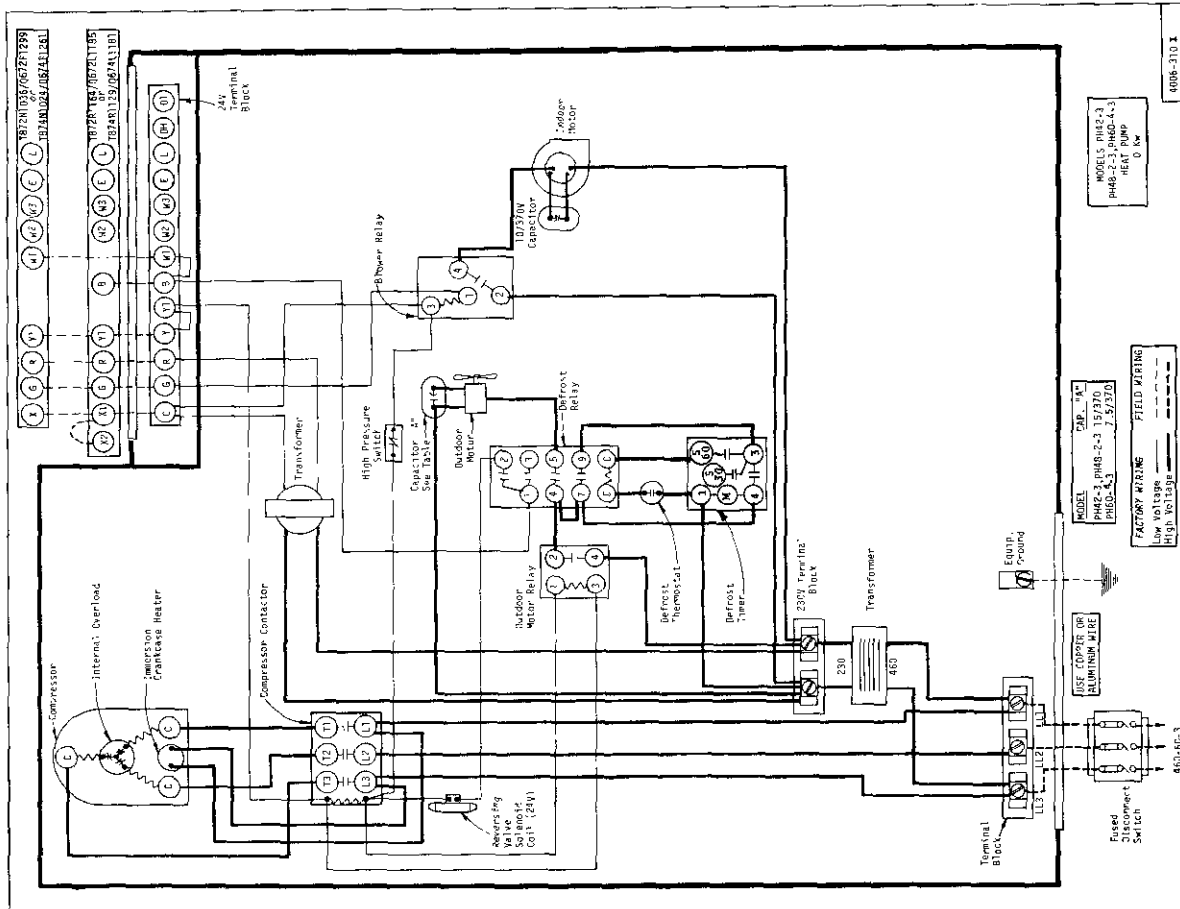

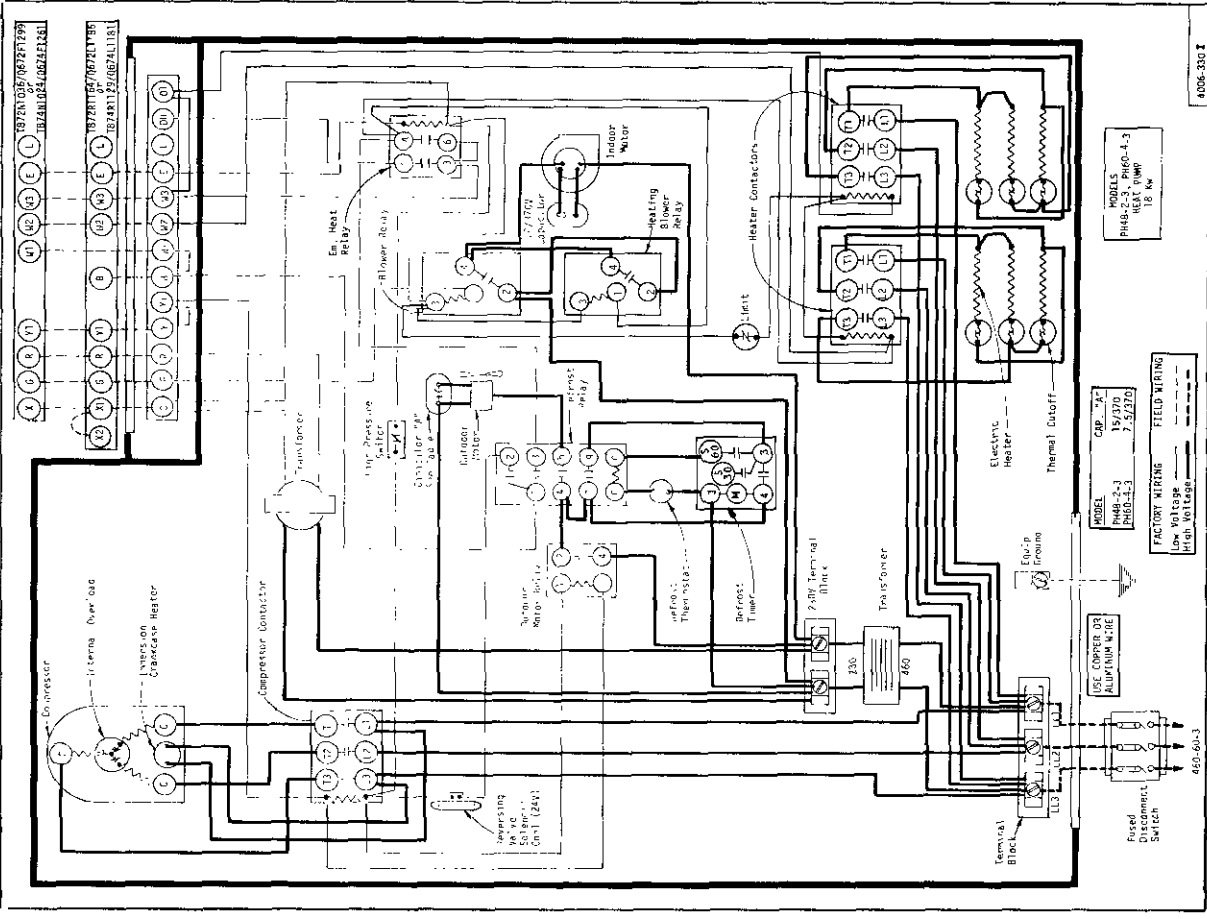
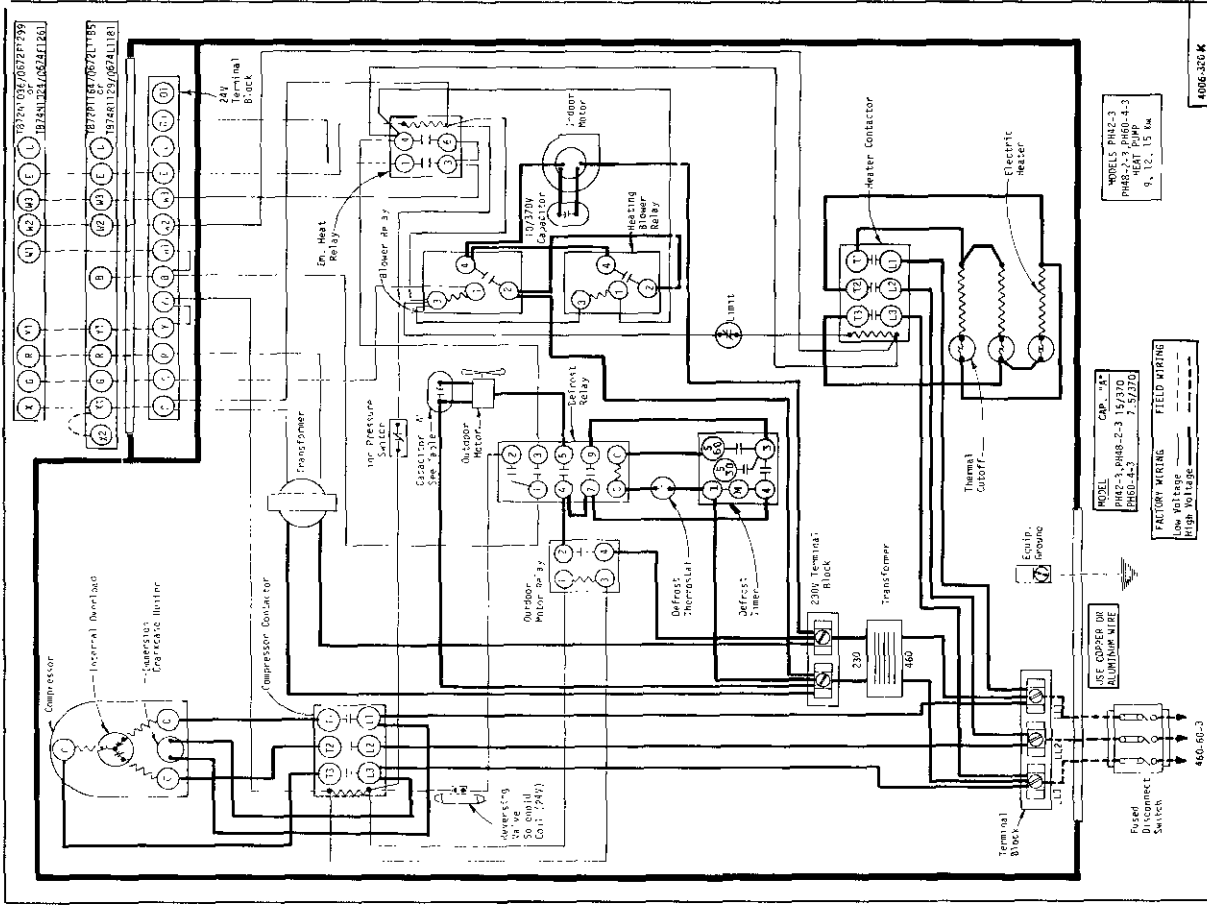

PART NO.	DESCRIPTION	PH42	PH42-3	PH48-2	PH48-2-3	PH60-4	PH60-4-3	PH42-3	PH48-2-3	PH60-4-3	PH60-4-3	
8604-046	Heat Strip 12Kw											
8604-050	Heat Strip 9Kw											
8604-052	Heat Strip 15Kw											
8406-010	High Pressure Switch											
8402-012	Limit Switch 130°											
8106-015	Motor - Blower 1/2 hp											
8105-021	Motor - Fan 1/3 hp											
8106-016	Motor - Fan 1/2 hp											
8200-003	Motor Mount - Blower											
8200-004	Motor Mount - Fan											
8451-011	Motor Mounting Parts											
8201-008	Relay - Blower											
8201-024	Relay - Compressor Fault											
8201-023	Relay - Defrost											
8201-013	Relay - Emergency Heat											
8650-006	Reversing Valve											
8650-010	Reversing Valve Solenoid Coil											
8201-024	Compressor Fault Relay											
8210-005	Strainer											
8607-010	Terminal Board											
8607-001	Terminal Block											
8607-003	Terminal Block											
8607-002	Terminal Block											
8402-025	Thermal Cut-off											
8612-011	Timer 30/60 Min											
8407-015	Transformer											
8407-004	Transformer - Stepdown											
7051-005	Condenser Grille											
7051-007	Wire Grille - Inlet											
8401-011	Contact - 30E0-30											

Minimum Net Billing \$15.00. Supersedes all previous lists. Subject to change without notice. F.O.B. Bryan, Ohio 43506.

PART NO.	DESCRIPTION	PH42	PH42-3	PH48-2	PH48-2-3	PH60-4	PH60-4-3	PH42-3	PH48-2-3	PH48-2-3	PH60-4-3
5202-005	Accumulator										
5202-008	Accumulator *										
5152-045	Blower Housing 10-9										
5152-015	Blower Wheel 0010-10A										
8552-030	Capacitor - Comp. 40/440V										
8552-005	Capacitor - Blower 10/370V										
8552-026	Capacitor - Fan 15/370V										
8552-036	Capacitor - Comp. 70/370V										
8552-004	Capacitor - Fan 7 1/2/370V										
8811-016	Capillary Tube - Cool										
8811-019	Capillary Tube - Heat										
8811-020	Capillary Tube - Cool										
8811-023	Capillary Tube - Heat										
8811-027	Capillary Tube - Cool										
8811-032	Capillary Tube - Heat										
5651-036	Check Valve										
5051-029	Condenser Coil										
8000-063	Compressor CRK1-0325-PEV-270										
8000-064	Compressor CRK1-0325-TF5-270										
8000-065	Compressor CRK1-0325-TFD-270										
8000-067	Compressor AG112E1-001-A4										
8000-030	Compressor AG111RT-004-A4										
8000-047	Compressor AG111UT-004-A4										
8000-074	Compressor AG134E1-002-A4										
8000-075	Compressor AG134RT-002-A4										
8000-049	Compressor AG133UT-003-A4										
8401-007	Contact - R8242A1008										
8401-002	Contact - 30B0-30										
8401-006	Contact - R8242B1006										
8401-003	Contact - R8243A1007										
8401-016	Contact - R8243A1189										
8408-004	Defrost Mounting Plate										
8408-002	Defrost Thermostat										
5060-025	Evaporator Coil										
5151-027	Fan Blade F12H9.5-2430 ccw										
5151-026	Fan Blade F12H9.5-2425x1/2 ccw										
8614-014	Fuse Block 15Kw										
8614-019	Fuse Block 20Kw										
8614-022	Fuse TR50										
8614-007	Fuse 60A										
8614-006	Fuse 30A										
8604-044	Heat Strip 10Kw										
8604-047	Heat Strip 15Kw										
8604-048	Heat Strip 9Kw										
8401-010	Contact - R8243B1005 (12-15Kw)										
8552-043	Capacitor - Compressor										

\*Please order by model number.

