

MANUAL 2100-047A

## INSTALLATION INSTRUCTIONS



# WALL MOUNTED PACKAGE HEAT PUMPS

**MODELS**  
**48WH2**

**BAR D MANUFACTURING COMPANY**  
P. O. Box 607      Bryan, Ohio 43506  
(419) 636-1194

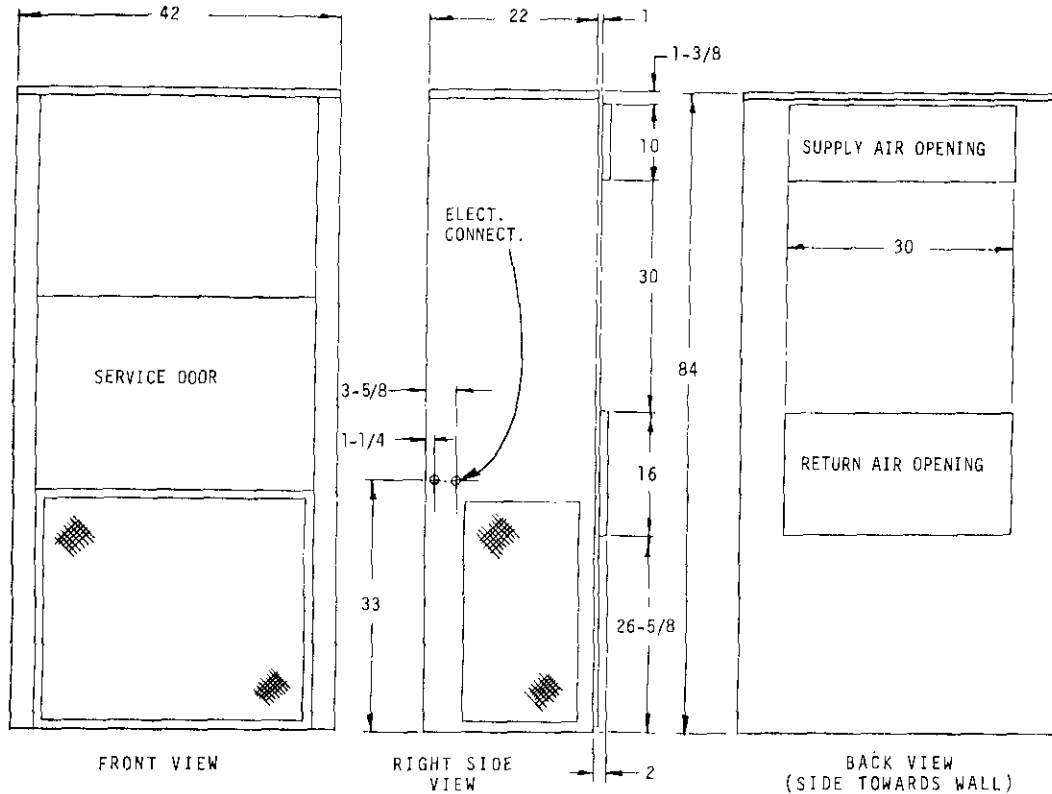

ELECTRICAL INFORMATION								WIRING INFORMATION**			
MODEL	Rated Volts & Ph	Operating Voltage Range	Heater* KW	Max Unit Amps	No. Field Power Circuits	Internal Fuses Ckt. A/B	Required $\Delta$ Overcurrent Protection	Min. Ckt. Ampacity Ckt. A/B	Field Power Wiring Ckt. A/B	Ground Wire Size Ckt. A/B	Wiring Diagram Number
48WH2	230/208-1	197-253	0	33.8	1		60	41	6	10	4014-110F
			5	54.6	2		60/30	41/26	6/10	10/10	-120F
			10	75.4	2		60/60	41/52	6/6	10/10	-130G
			15	96.3	2	60/60 & 30	60/80	41/78	6/3	10/8	-140H
20	117	2	60/60 & 30	60/110	41/104	6/1	10/6	-150H			
48WH2	230/208-3	187-253	0	25.8	1		45	31	8	10	4014-210F
			9	47.5	2		45/30	31/27	8/10	10/10	-220H
			12	54.7	2		45/40	31/36	8/8	10/10	-230H
			15	62	2		45/45	31/45	8/6	10/10	-230H
18	69.2	2		45/60	31/54	8/4	10/10	-240J			
48WH2	460-3	414-506	0	10.4	1		15	15	14	14	4014-310F
			9	21.2	1		30	26	70	10	-320H
			12	24.8	1		30	30	10	10	-320H
			15	28.4	1		35	35	8	10	-320H
18	32.1	1		40	39	8	10	-330I			

\*Electric heaters are nominal Kw @ 240 or 480V.  
 \*\*Based on 60°C copper wire. Other wiring materials must be rated for marked minimum circuit ampacity or greater. Not all models are approved for aluminum wire.

$\Delta$  Time delay fuses or "HACR Type" circuit breakers must be used for 60 and smaller sizes. Standard fuses or circuit breakers suitable for sizes 70 and larger.

# APPLICATION AND INSTALLATION INSTRUCTIONS FOR WH-SERIES PACKAGE HEAT PUMPS

## IMPORTANT

The equipment covered in this manual is to be installed by trained, experienced service and installation technicians. Any heat pump is more critical of proper operating, charge and an adequate duct system than a straight air conditioning unit. All ductwork, supply and return, must be properly sized for the design air flow requirement of the equipment. NESCA is an excellent guide to proper sizing. All duct work or portions thereof not in the conditioned space should be properly insulated in order to both conserve energy and prevent condensation or moisture damage.

## SHIPPING DAMAGE

Upon receipt of equipment, the carton should be checked for external signs of shipping damage. If damage is found, the receiving party must contact the last carrier immediately, preferably in writing, requesting inspection by the carrier's agent.

## GENERAL

The refrigerant system is completely assembled and charged. All internal wiring is complete.

The unit is designed for use with or without duct work. Flanges are provided for attaching the supply and return ducts.

These instructions explain the recommended method to install the air cooled self-contained unit and the electrical wiring connections to the unit.

These instructions and any instructions packaged with any separate equipment required to make up the entire air conditioning system should be carefully read before beginning the installation. Note particularly "Starting Procedure" and any tags and/or labels attached to the equipment.

While these instructions are intended as a general recommended guide, they do not supersede any national and/or local codes in any way. Authorities having jurisdiction should be consulted before the installation is made.

## INSTALLATION

Size of unit for a proposed installation should be based on heat loss calculation made according to methods of National Warm Air Heating and Air Conditioning Association. The air duct should be installed in accordance with the Standards of the National Fire Protection Association for the Installation of Air Conditioning and Ventilating Systems of Other Than Residence Type, NFPA No. 90A, and Residence Type Warm Air Heating and Air Conditioning Systems, NFPA No. 90B. Where local regulations are at a variance with instructions, installer should adhere to local codes.

## DUCTWORK

Design the ductwork according to methods given by the National Warm Air Heating and Air Conditioning Association. When duct runs through unheated spaces, it should be insulated with a minimum of two inches of insulation. Use insulation with a vapor barrier on the outside of the insulation. Flexible joints should be used to connect the ductwork to the equipment in order to keep the noise transmission to a minimum.

A one inch clearance to combustible material for the first three feet of duct attached to the outlet air frame is required. See page 6 for further details.

## FILTER

A 1" throwaway filter is supplied with each unit. The filter slides into position making it easy to service. This filter can be serviced from the outside by removing the service door.

## FRESH AIR INTAKE

All units are built with a fresh air inlet hole punched in the service panel. The fresh air damper assembly is shipped with each unit, and must be attached at the installation site. See Figure 1 for typical installation procedure.

The fresh air damper assembly is standard equipment with the unit because of the variety of state or local codes requiring fresh air capability.

All capacity, efficiency and cost of operation information as required for Department of Energy "Energy-guide" Fact Sheets is based upon the fresh air blank-off plate in place and is recommended for maximum energy efficiency.

The blank-off plate is available upon request from the factory and is installed in place of the fresh air damper shipped with each unit.

## WALL MOUNTING

1. Two holes, the size of the supply and return air openings must be cut through the wall as shown in Figure 2.
2. On wood-frame walls, the wall construction must be strong and rigid enough to carry the weight of the unit without transmitting any unit vibration.
3. Concrete block walls must be thoroughly inspected to insure that they are capable of carrying the weight of the installing unit.
4. Ducts through the walls must be insulated and all joints taped or sealed to prevent air or moisture entering the wall cavity.
5. Some installations may not require any return air duct. It is recommended that on this type of installation that a filter grille be located in the wall. Filters must be of sufficient size to allow a maximum velocity of 400 FPM.

NOTE: If no return air duct is used, applicable installation codes may limit this cabinet to installation only in a single story structure.

## WIRING - MAIN POWER

Refer to the unit rating plate for wire sizing information and maximum fuse or "HACR Type" circuit breaker size. Each outdoor unit is marked with a "Minimum Circuit Ampacity." This means that the field wiring used must be sized to carry that amount of current. Depending on the installed Kw of electric heat, there may be two field power circuits required. If this is the case, the unit serial plate will so indicate. Some models are suitable only for connection with copper wire, while others can be wired with either copper or aluminum wire. Each unit and/or wiring diagram will be marked "Use Copper Conductors Only" or "Use Copper or Aluminum Conductors." These instructions MUST BE adhered to. Refer to the National Electrical Code for complete current carrying capacity data on the various insulation grades of wiring material.

The electrical data lists fuse and wire sizes (60°F copper) for all models, including the most commonly used center sizes. Also shown are the number of field power circuits required for the various models with heaters.

The unit rating plate lists a "Maximum Time Delay Fuse" or "HACR Type" circuit breaker that is to be used with the equipment. The correct size must be used for proper circuit protection and also to assure that there will be no nuisance tripping due to the momentary high starting current of the compressor motor.

#### WIRING - 24V CONTROL CIRCUIT

Nine (9) wires should be run from thermostat subbase to the 24V terminal board in the unit. A nine conductor, 18 gauge copper, color-coded thermostat cable is recommended. The connection points are shown on most of the wiring diagrams and are also shown below.

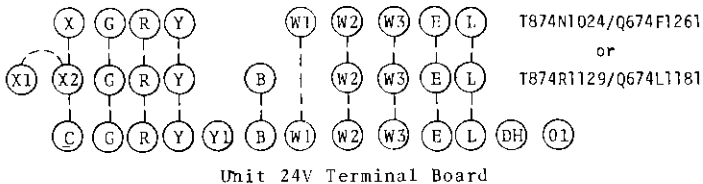

**IMPORTANT NOTE:** Only the thermostat and subbase combinations as shown above will work with this equipment. The stat and subbase MUST be matched, and correct operation can be assured only by proper selection and application of these parts.

#### CONDENSATE DRAIN

A plastic drain hose extends from the drain pan at the top of the unit down to the unit base. There are openings in the unit base for the drain hose to pass through. In the event the drain hose is connected to a drain system of some type, it must be an open or vented type system to assure proper drainage.

#### COMPRESSOR MALFUNCTION RELAY (Single Phase Models Only)

Actuation of the green "check" lamp is accomplished by a voltage type relay which is factory installed. Any condition such as loss of charge, defective capacitor, defective contactor, etc., that will prevent compressor from operating will cause green lamp to activate. This is a signal to the operator of the equipment to place system in emergency heat position.

#### PRESSURE SERVICE PORTS

High and low pressure service ports are installed on all units so that the system operating pressures can be observed. Pressure curves can be found later in the manual covering all models on both cooling and heating cycles. It is imperative to match the correct pressure curve to the unit by model number.

#### SEQUENCE OF OPERATION

**Cooling** - Circuit R-Y makes at thermostat pulling in compressor contactor starting the compressor and outdoor motor. The G (indoor motor) circuit is automatically completed on any call for cooling operation, or can be energized by manual fan switch on subbase for constant air circulation.

**Heating** - A 24V solenoid coil on reversing valve controls heating cycle operation. Two thermostat options, one allowing "Auto" changeover from cycle to cycle and the other constantly energizing solenoid coil during heating season and thus eliminating pressure equalization noise except during defrost, are to be used. On "Auto" option, a circuit is completed from R-W1 and R-Y on each heating "on" cycle, energizing reversing valve solenoid and pulling in compressor contactor starting compressor and outdoor motor. R-G also make starting indoor blower motor. Heat pump heating cycle now in operation. The second option has no "Auto" changeover position, but instead energizes the reversing valve solenoid constantly whenever the system switch on subbase is placed in "Heat" position, the "B" terminal being constantly energized from R. A thermostat demand for heat completes R-Y circuit, pulling in compressor contactor starting compressor and outdoor motor. R-G also make starting indoor blower motor.

#### COMPRESSOR CUT-OFF THERMOSTAT AND OUTDOOR THERMOSTATS

Heat pump compressor operation at outdoor temperatures below 0°F are neither desirable nor advantageous in terms of efficiency. Since most equipment at time of manufacture is not designated for any specific destination of the country, and most of the equipment is installed in areas not approaching the lower outdoor temperature range, the compressor cut-offs are not factory installed.

Outdoor thermostats are available to hold off various banks of electric heat until needed as determined by outdoor temperature. The set point of either type of thermostat is variable with geographic region and sizing of the heating equipment to the structure. Utilization of the Heating Application Data and the heat loss calculation of the building are useful in determining the correct set points.



#### COMPRESSOR CUT-OFF & OUTDOOR THERMOSTAT WIRING

SEE SPECIFIC WIRING INFORMATION ON PAGE 7.

#### HEAT ANTICIPATION

Both of the thermostats shown below have a fixed heat anticipator for stage 1 with no adjustment required. Stage 2 has an adjustable anticipator for the W2 connection and fixed for the W3 connection. Both the W2 and W3 circuits are controlled by the stage 2 bulb. The only heat anticipator that needs to be checked is stage 2 and it should be set to match the load carried by the W2 circuit. The normal factory wiring provides for only one electric heat contactor to be controlled by W2, and the anticipator should be set at .40A. If special field wiring is done, it is best to actually measure the load but a good rule is .40A for each heat contactor controlled by W2.

#### WALL THERMOSTAT AND SUBBASE COMBINATIONS

Group	Thermostat	Subbase	Predominant Feature
A	8403-017 (T874R1129)	8404-009 (Q674L1181)	Heat or Cool No Auto 
B	8403-018 (T874N1024)	8404-010 (Q674F1261)	Automatic Heat-Cool Changeover Position 

 No automatic changeover position—must manually place in heat or cool. Reversing valve remains energized at all times system switch is in heat position (except during defrost cycle). No pressure equalization noise when thermostat is satisfied on either heating or cooling.

 Allows thermostat to control both heating and cooling operation when set in "AUTO" position. Reversing valve de-energizes at end of each "ON" heating cycle.

**IMPORTANT NOTE:** Both thermostat and subbase combinations shown above incorporate the following features; Man-Auto fan switch, Off-Heat-Cool-Em. Heat Switch, and two (2) indicator lamps—one for emergency heat and one for compressor malfunction.

#### THERMOSTAT INDICATOR LAMPS

The red lamp marked "EM.HT." comes on and stays on whenever the system switch is placed in the Em. Ht. position. The green lamp marked "check" will come on if there is any problem that prevents the compressor from running when it is supposed to be.

#### EMERGENCY HEAT POSITION

The operator of the equipment must manually place the system switch in this position. This is done when there is a known problem with the outdoor section, or when the green "check" lamp comes on indicating a problem.

## DEFROST CYCLE

The defrost cycle is controlled by time and temperature. The 240 volt timer motor runs all the time the compressor is in operation. When the outdoor temperature is in the lower 40°F temperature range or colder, the outdoor coil temperature is 32°F or below. This temperature is sensed by the defrost thermostat mounted near the bottom of the outdoor coil on a return bend. The defrost thermostat closes at approximately 32°F. Every 60 (or 30) minutes that the compressor is running, contacts 3-5 close for 7 minutes, with contacts 3-4 closed for the first 40 seconds of that 7 minutes. If the defrost thermostat is closed, the defrost relay energizes and places the system in defrost mode. An interlocking circuit is created with timer contact 3-5 and defrost relay contact 7-9 in series.

During the defrost mode, the refrigerant cycle switches back to the cooling cycle, the outdoor motor stops, electric heaters are energized, and hot gas passing through the outdoor coil melts any accumulated frost. When the temperature rises to approximately 57°F, the defrost thermostat opens, de-energizing the defrost relay and returning the system to heating operation.

If some abnormal or temporary condition such as a high wind causes the heat pump to have a prolonged defrost cycle, contacts 3-5 of the defrost timer will open after 7 minutes and restore the system to heating operations automatically.

There are two time settings on the defrost timer-- 30 minutes and 60 minutes. Most models are shipped wired on the 60 minute setting for greatest operating economy. If special circumstances require a change to the shorter time, remove wire connected to terminal 5/60 and reconnect to terminal 5/30.

There is a manual advance knob located on the timer. This can be used to advance timer to contact closure point if it is desired to check out defrost cycle operation, without waiting for time to elapse.

### DEFROST TIMER WIRING

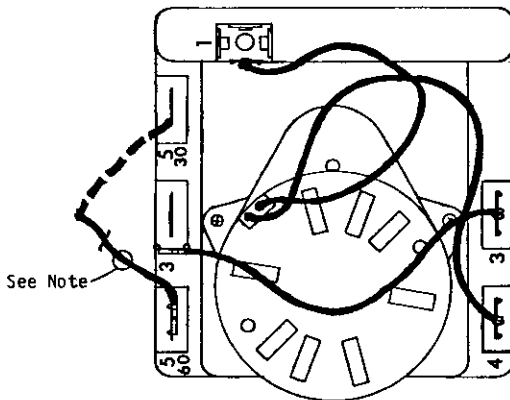

NOTE: All models are connected to 5/60 terminal (60 minute). Any model can be changed from 60 minutes to 30 minutes by unplugging from 5/60 terminal and reconnecting to 5/30 terminal as shown by dotted line.

### SERVICE HINTS

1. Caution homeowner to maintain clean air filters at all times. Also, not to needlessly close off supply and return air registers. This reduces air flow through the system, which shortens equipment service life as well as increasing operating costs.
2. Switching to heating cycle at 75°F or higher outside temperature may cause a nuisance trip of the manual reset high pressure switch.
3. The heat pump wall thermostats perform multiple functions. Be sure that all function switches are correctly set for the desired operating mode before trying to diagnose any reported service problems.

4. Check all power fuses or circuit breakers to be sure that they are the correct rating.
5. Periodic cleaning of the outdoor coil to permit full and unrestricted airflow circulation is essential.

### IMPORTANT INSTALLER NOTES:

1. For improved start-up performance wash the indoor coil with a dishwasher detergent.

### CRANKCASE HEATERS

All units are provided with some form of compressor crankcase heat. Some single phase units utilize the compressor motor start winding in series with a portion of the run capacitor to generate heat within the compressor shell to prevent liquid refrigerant migration.

Some three phase units utilize a wraparound type of crankcase heater that warms the compressor oil from the outside.

Some single and three phase models have an insertion well-type heater located in the lower section of the compressor housing. This is a self-regulating type heater that draws only enough power to maintain the compressor at a safe temperature.

Some form of crankcase heat is essential to prevent liquid refrigerant from migrating to the compressor, causing oil pump out on compressor start-up and possible valve failure due to compressing a liquid.

Refer to unit wiring diagram to find exact type of crankcase heater used.

The following decal is affixed to all outdoor units detailing start-up procedure. This is very important. Please read carefully.

### IMPORTANT

THESE PROCEDURES MUST BE FOLLOWED AT INITIAL START-UP AND AT ANY TIME POWER HAS BEEN REMOVED FOR 12 HOURS OR LONGER.

10 PREVENT COMPRESSOR DAMAGE WHICH MAY RESULT FROM THE PRESENCE OF LIQUID REFRIGERANT IN THE COMPRESSOR CRANKCASE

1 MAKE CERTAIN THE ROOM THERMOSTAT IS IN THE OFF POSITION (THE COMPRESSOR IS NOT TO OPERATE)

2 APPLY POWER BY CLOSING THE SYSTEM DISCONNECT SWITCH THIS ENERGIZES THE COMPRESSOR HEATER WHICH EVAPORATES THE LIQUID REFRIGERANT IN THE CRANKCASE

3 ALLOW 4 HOURS OR 60 MINUTES PER POUND OF REFRIGERANT IN THE SYSTEM AS NOTED ON THE UNIT RATING PLATE WHICH EVER IS GREATER

4 AFTER PROPERLY ELAPSED TIME THE THERMOSTAT MAY BE SET TO OPERATE THE COMPRESSOR

5 EXCEPT AS REQUIRED FOR SAFETY WHILE SERVICING - DO NOT OPEN SYSTEM DISCONNECT SWITCH

796-051

UNIT MODELS

20WA1  
24WA2  
18WH2  
24WH2

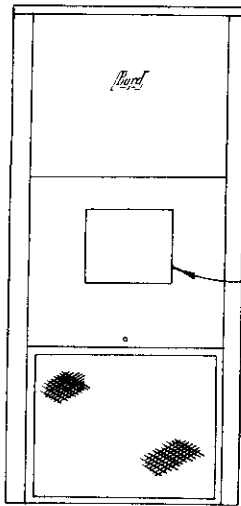

Model FAD10  
Fresh Air Cover  
With Adjustable  
Damper

UNIT MODELS

30WA2  
36WA4  
30WH1  
36WH2  
42WA  
49WA  
48WH2

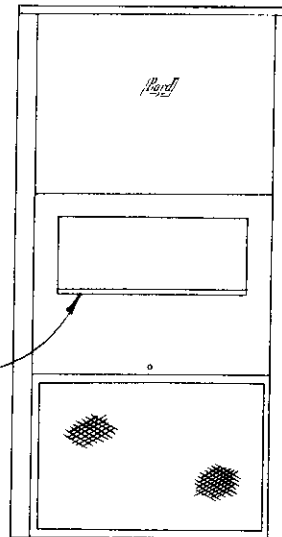

MODEL FAD25  
Fresh Air Cover  
With Adjustable  
Damper

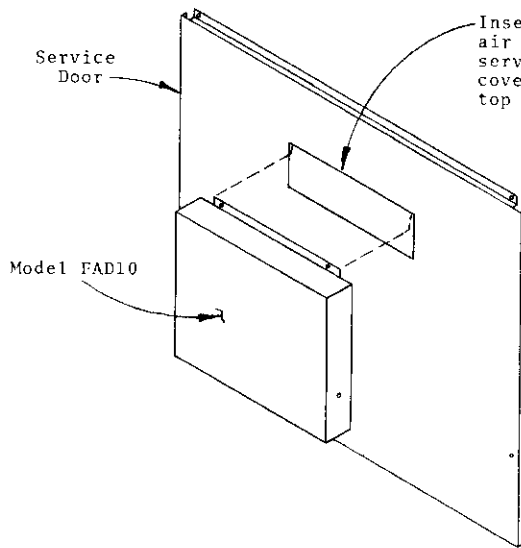

Insert top flange of fresh air cover into opening in service door and push top of cover assembly all the way to top of opening.

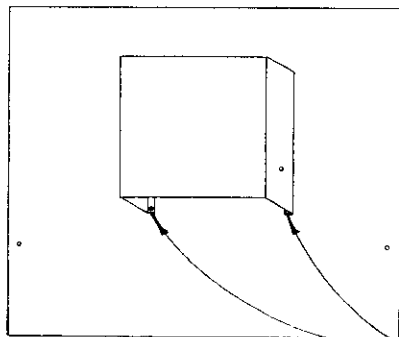
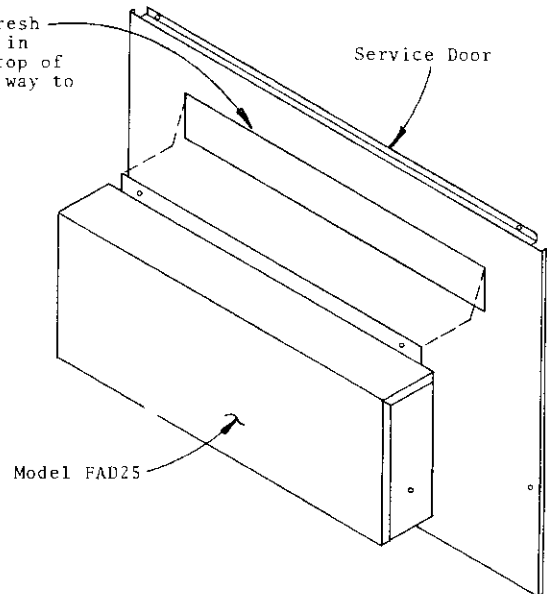

Secure bottom of Fresh Air Cover Assembly with two screws.

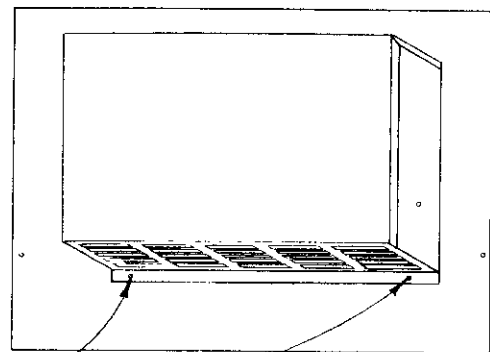
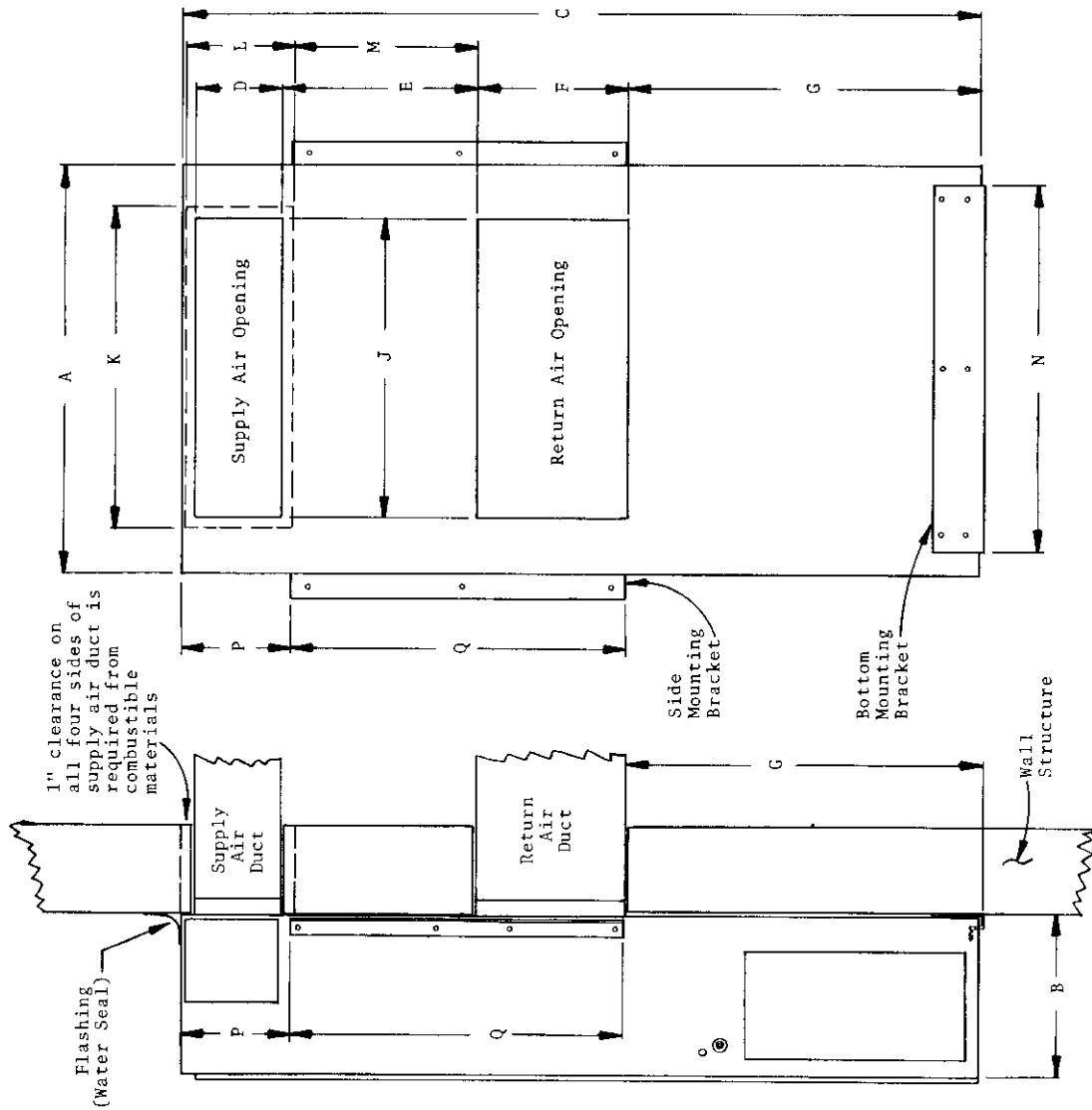

FIGURE 1

SIDE VIEW

WALL VIEW



MOUNTING INSTRUCTIONS

1. These units are secured by wall mounting brackets which secure the unit to the outside wall surface at both sides and at the bottom.
2. The unit itself is suitable for "0" inch clearance, but the supply air duct flange and the first few feet of supply air duct require 1 inch clearance to combustible material. If combustible wall, use K and L dimensions for sizing, if non-combustible, use D and J.
3. After the wall opening positions have been selected, lay out the position for the bottom and side brackets. Fasten the brackets securely to the wall (type of fasteners will depend on wall construction).
4. Be sure to observe the P dimension when attaching the side brackets. This will assure that no screws are driven into the unit sides damaging any internal parts. One-half inch sheet metal screws are recommended.
5. For additional mounting rigidity, the return air and supply air (depending upon wall construction) frames or collars can be drilled and screwed or welded to the structural wall itself. Be sure to observe required clearance if combustible wall.

MODEL	A	B	C	D	E	F	G	J	K	L	M	N	P	Q
20WA1, 24WA2	32-1/4	13-1/2	69-5/8	8	20-1/2	12	27-1/2	20	22	10	19-1/2	24	10	31
18WH2, 24WH2														
30WA2, 36WA4	38-1/4	15-1/4	74	8	18	14	32-5/8	28	30	10	17	34	10	31
30WH1, 36WH2														
42WA, 49WA	42	22	84	10	30	16	26-5/8	30	32	12	29	34	10	42
48WH2														

FIGURE 2

**FAN BLADE SETTING DIMENSIONS**

Shown in the drawing below are the correct fan blade setting dimensions for proper air delivery across the outdoor coil.

Any service work requiring removal or adjustment in the fan and/or motor area will require that the dimensions below be checked and blade adjusted in or out on the motor shaft accordingly.

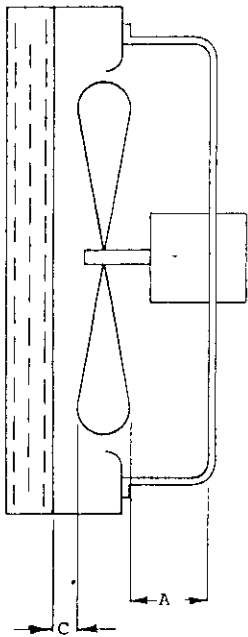

MODEL	DIM. A	DIM. C
48WH2	1	4-5/8

**COMPRESSOR CUT-OFF AND OUTDOOR THERMOSTAT WIRING**

5,10,15Kw 1-PH — 9,12,15Kw 3-PH

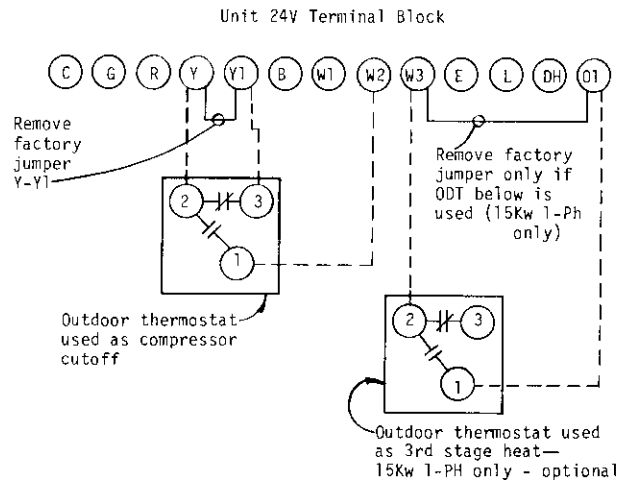

20Kw 1-PH — 18Kw 3-PH

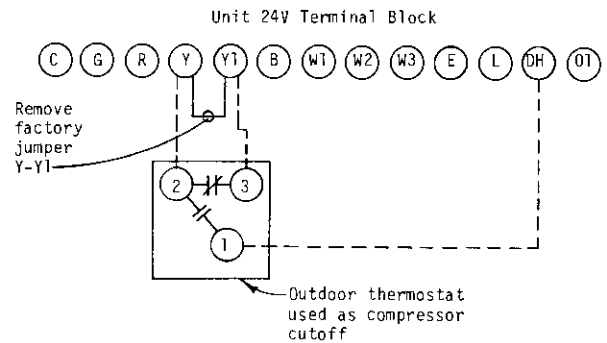

**REFRIGERANT CHARGE**

The correct system R-22 charge is shown on the unit rating plate. Optimum unit performance will occur with a refrigerant charge resulting in a suction line temperature (6" from compressor) as shown in the following table:

RATED CFM AND E.S.P. (WET COIL—COOLING)			
MODEL	RATED CFM	RATED E.S.P.	RECOMMENDED AIRFLOW RANGE
48WH2	1650	.33	1440-1770 CFM

The above suction line temperatures are based upon 80°F dry bulb/67°F wet bulb (50% R.H.) temperature and rated airflow across the evaporator during cooling cycle.

MODEL	AIRFLOW	95°F O.D. Temp.	82°F O.D. Temp.
48WH2	1650	67-69	74-76

INDOOR BLOWER PERFORMANCE CFM — DRY COIL WITH FILTER	
E.S.P. Inches H <sub>2</sub> O	MODEL 48WH2
.0	2125
.1	2035
.2	1950
.3	1845
.4	1735
.5	1620
.6	1490



BARD MANUFACTURING COMPANY  
MODEL 48MHZ

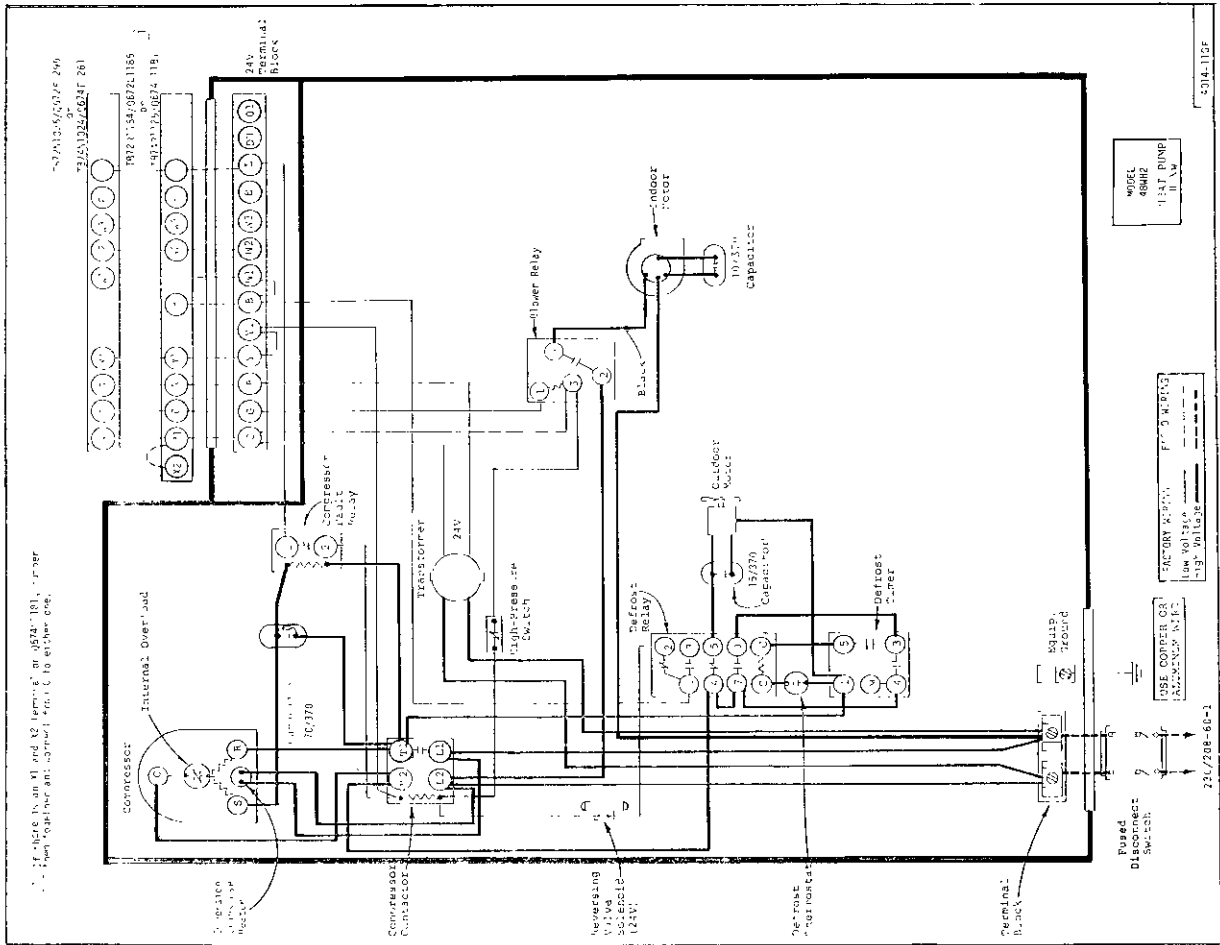
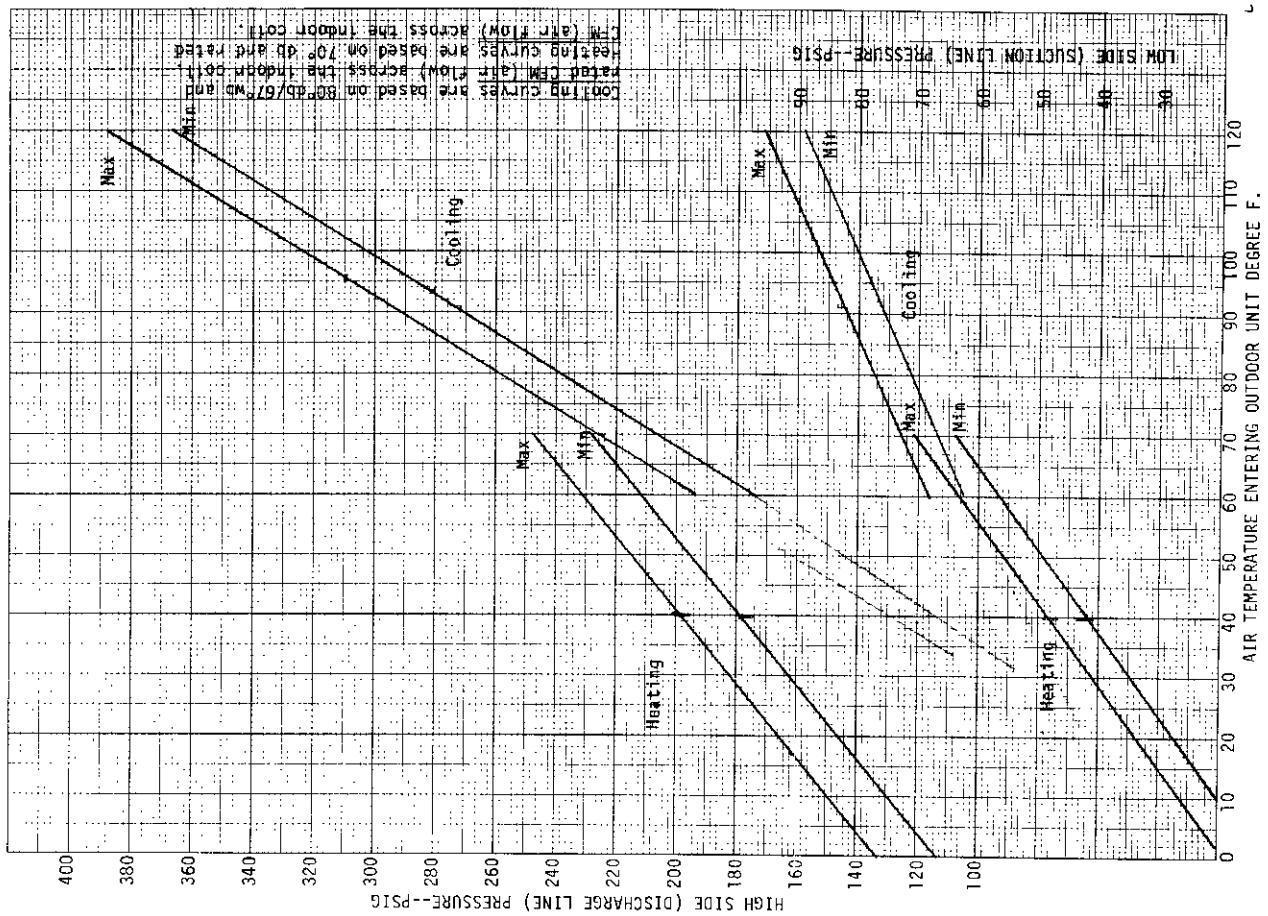

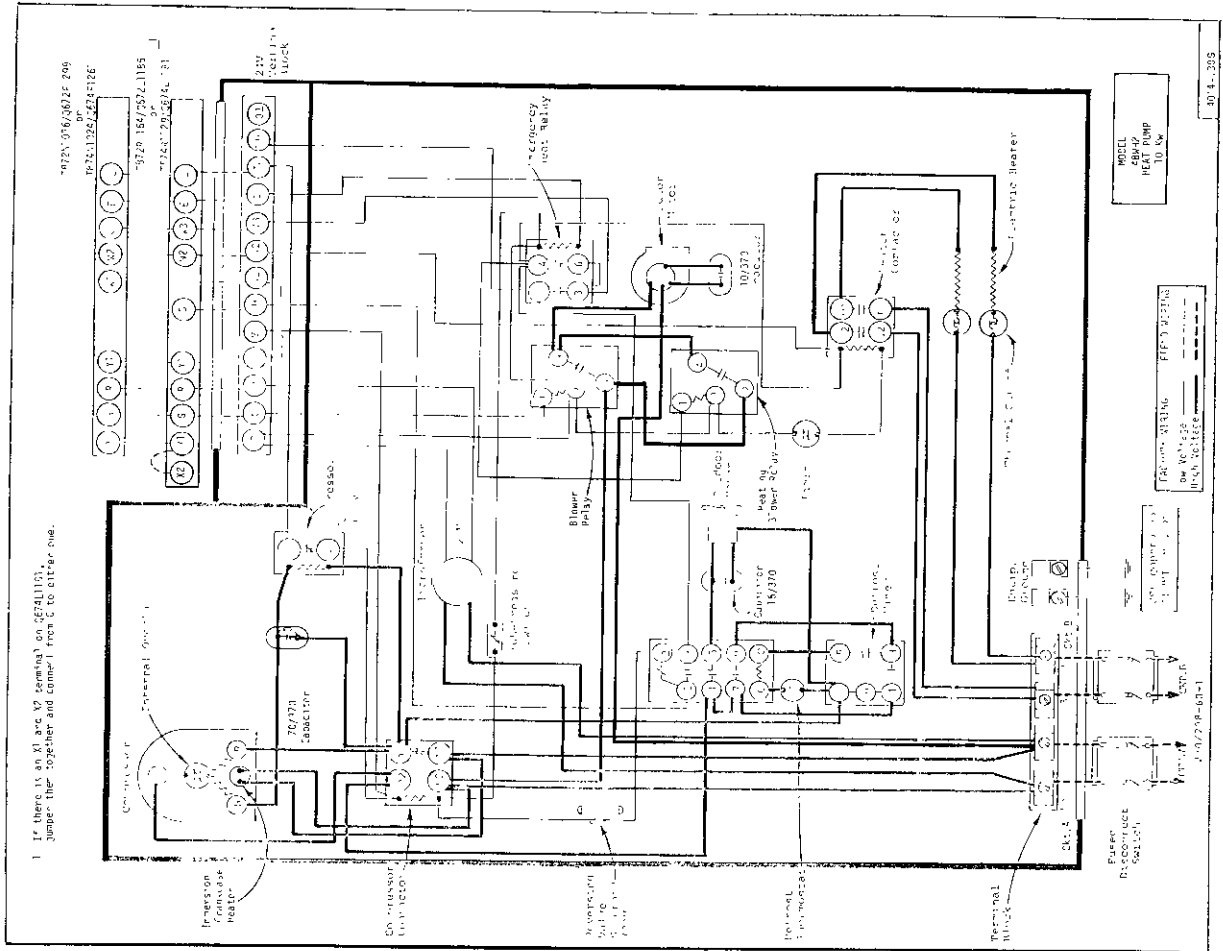
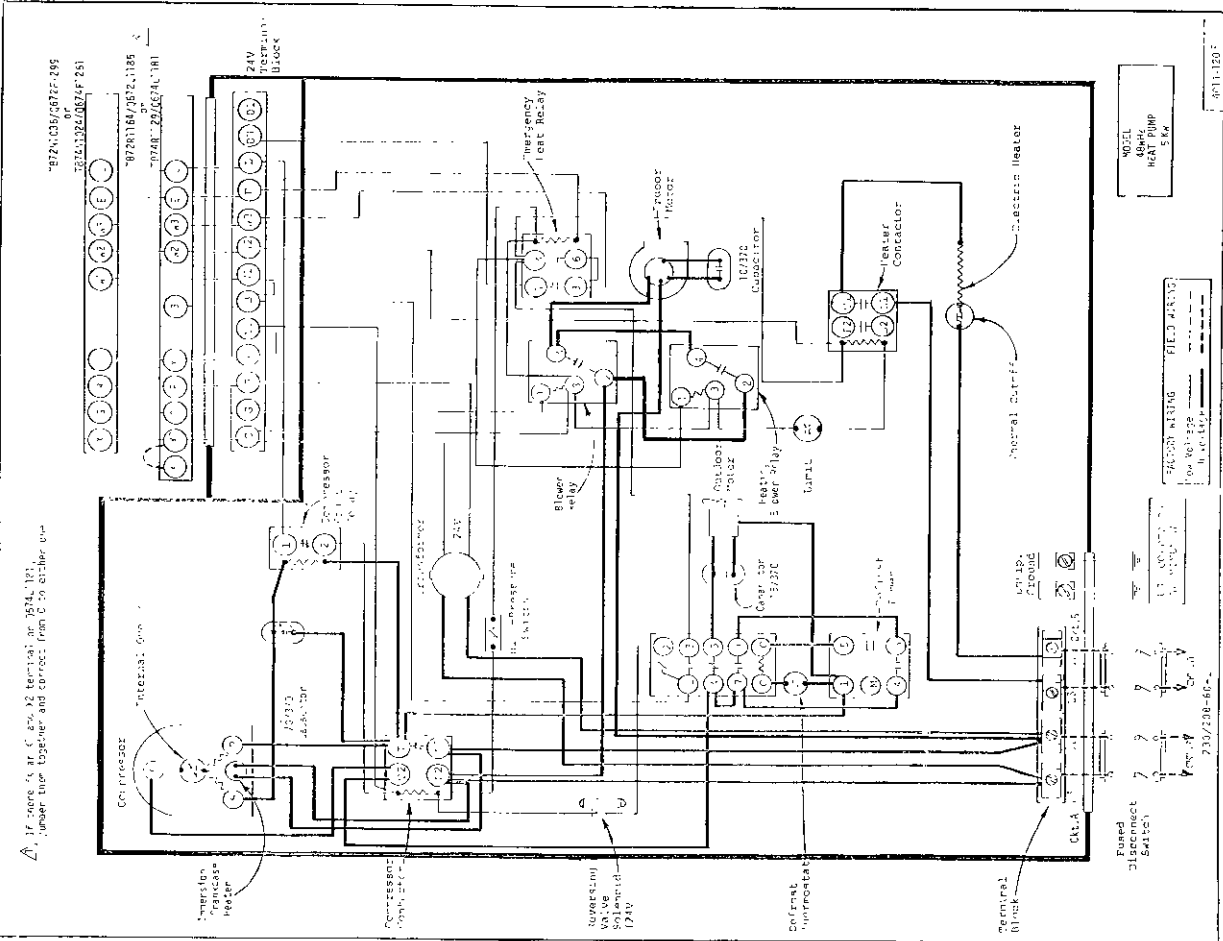

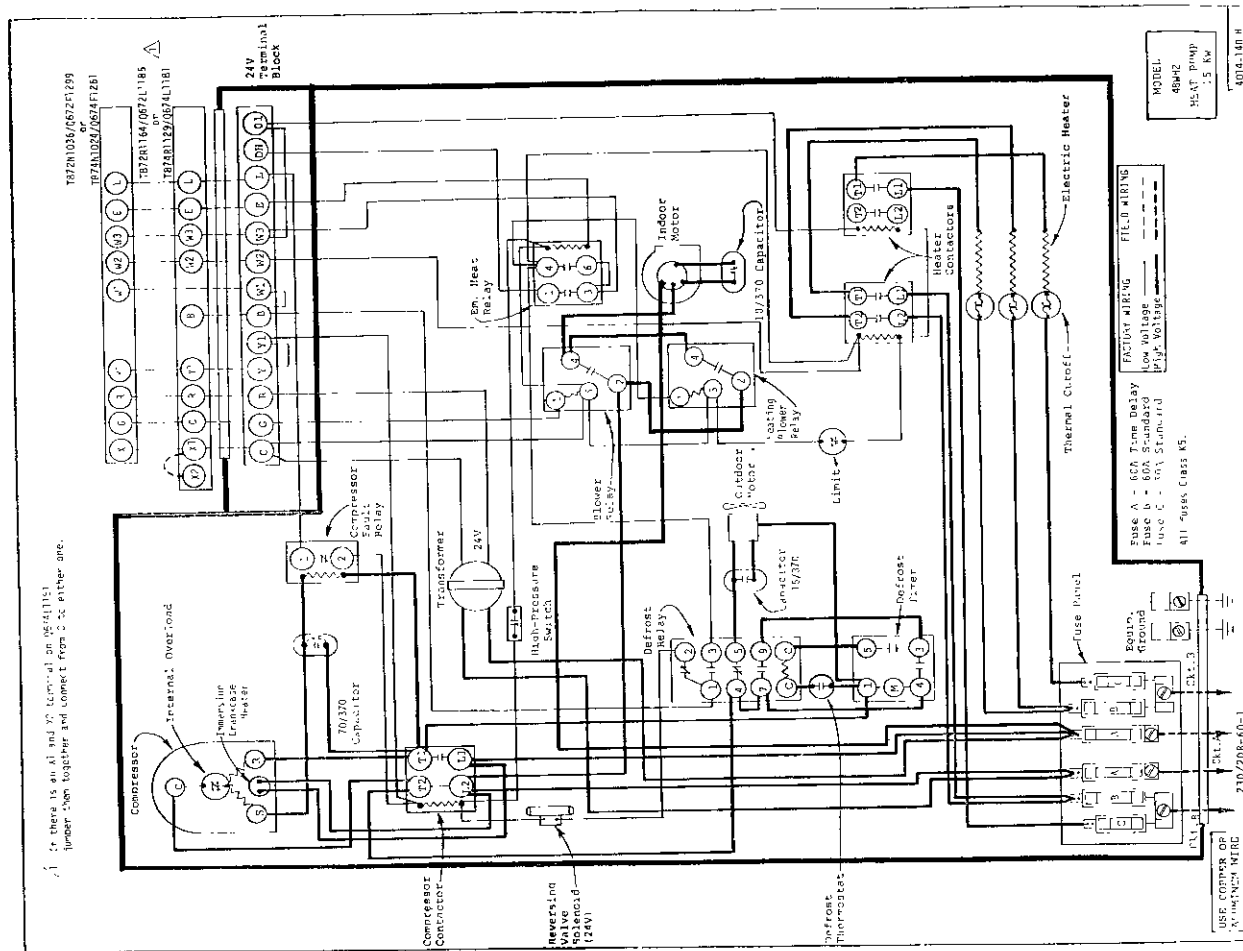
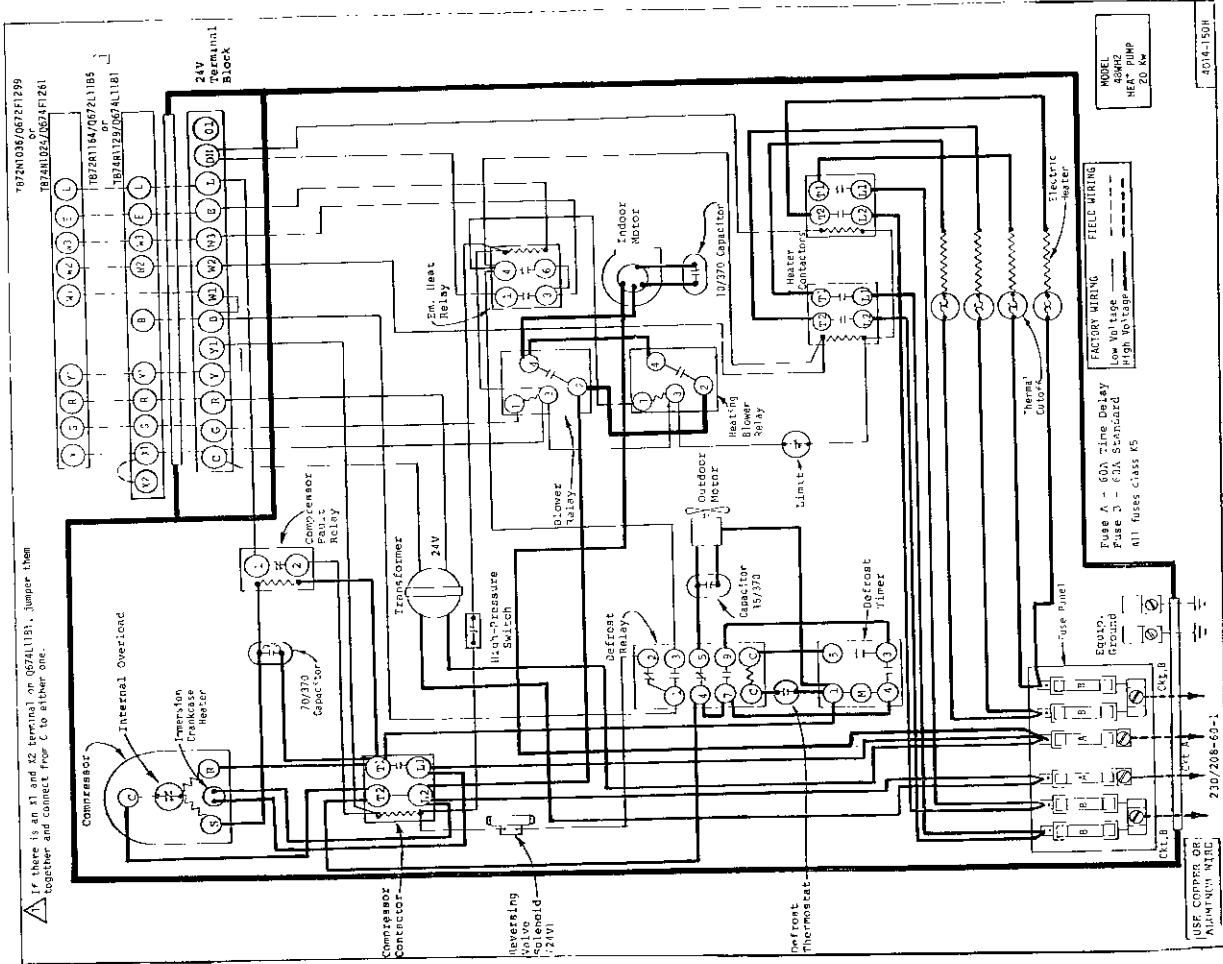

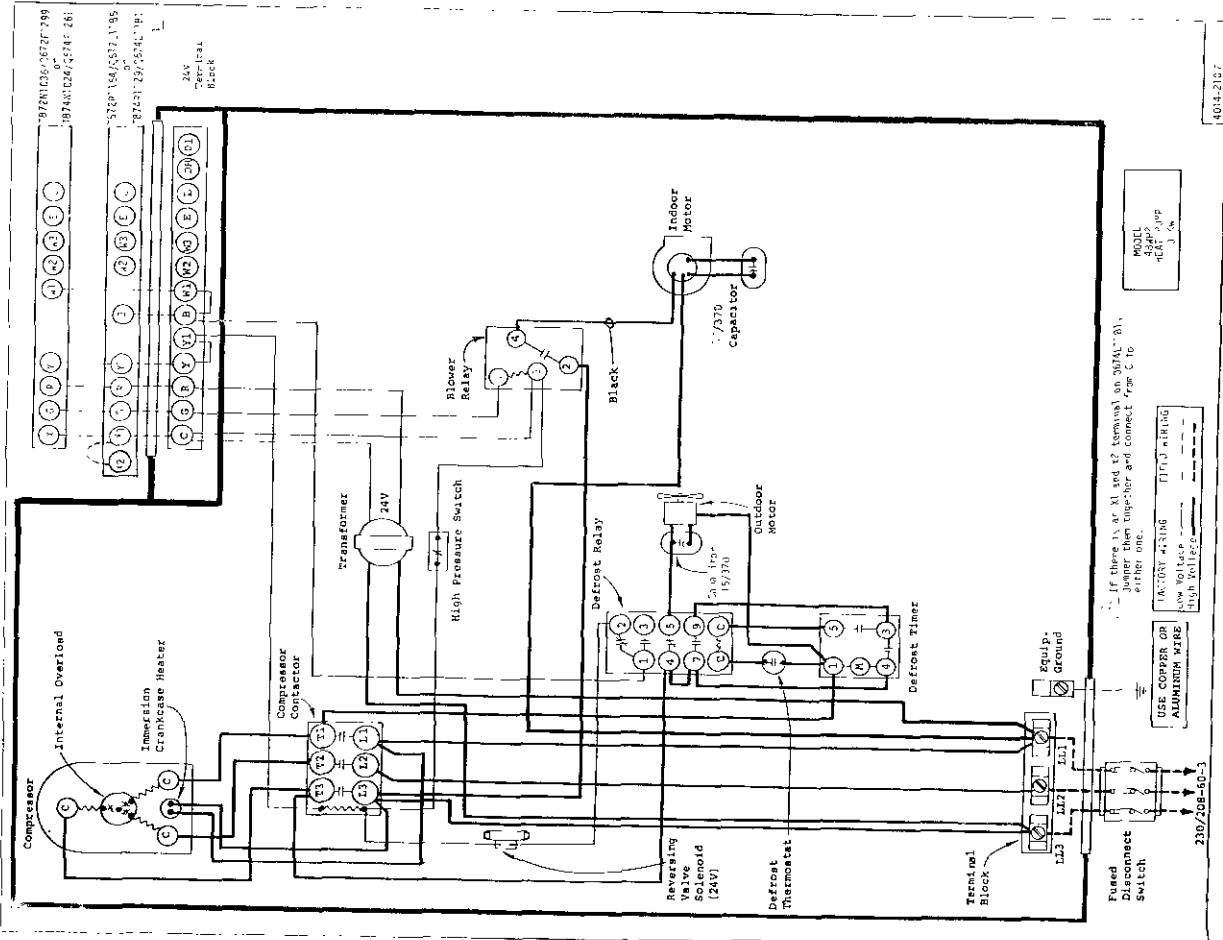
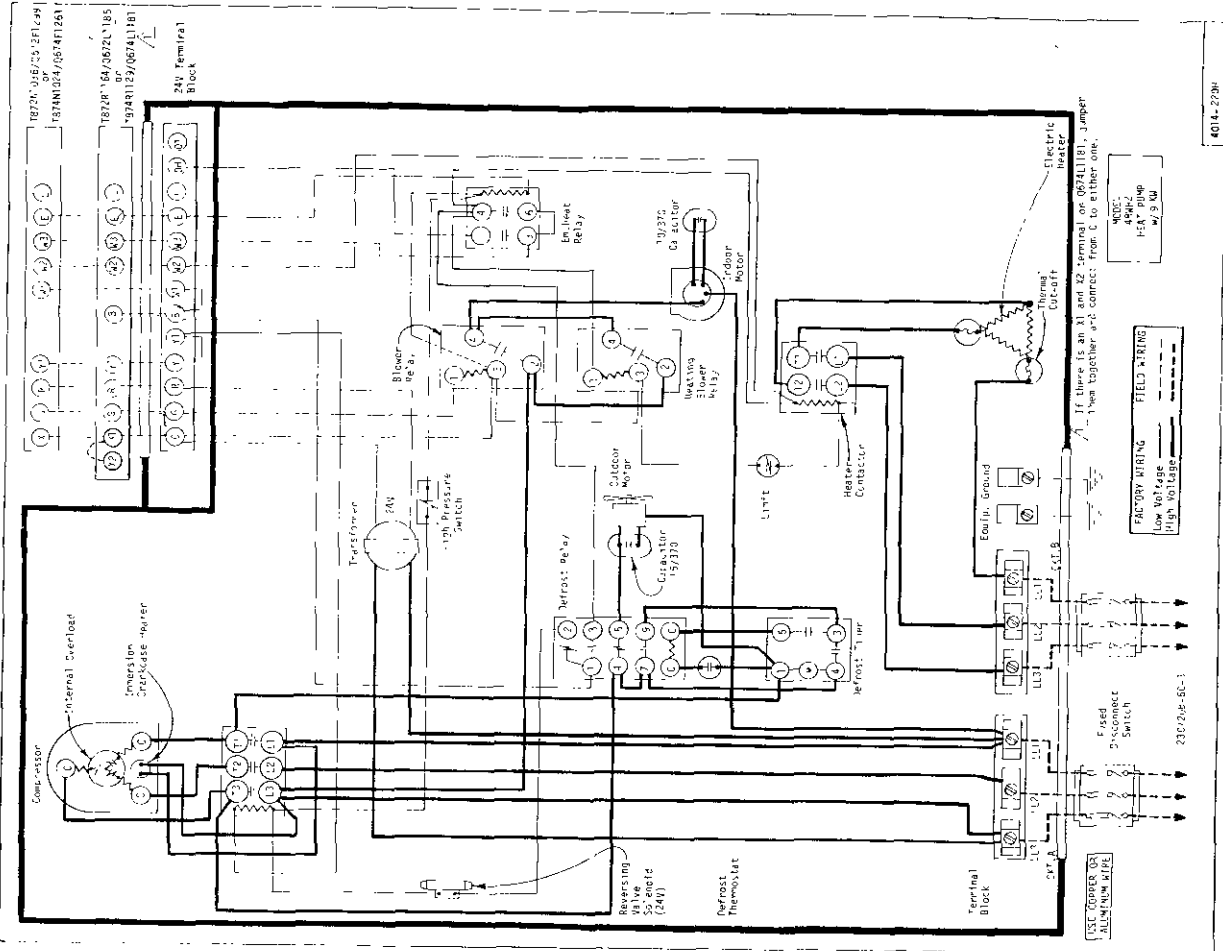

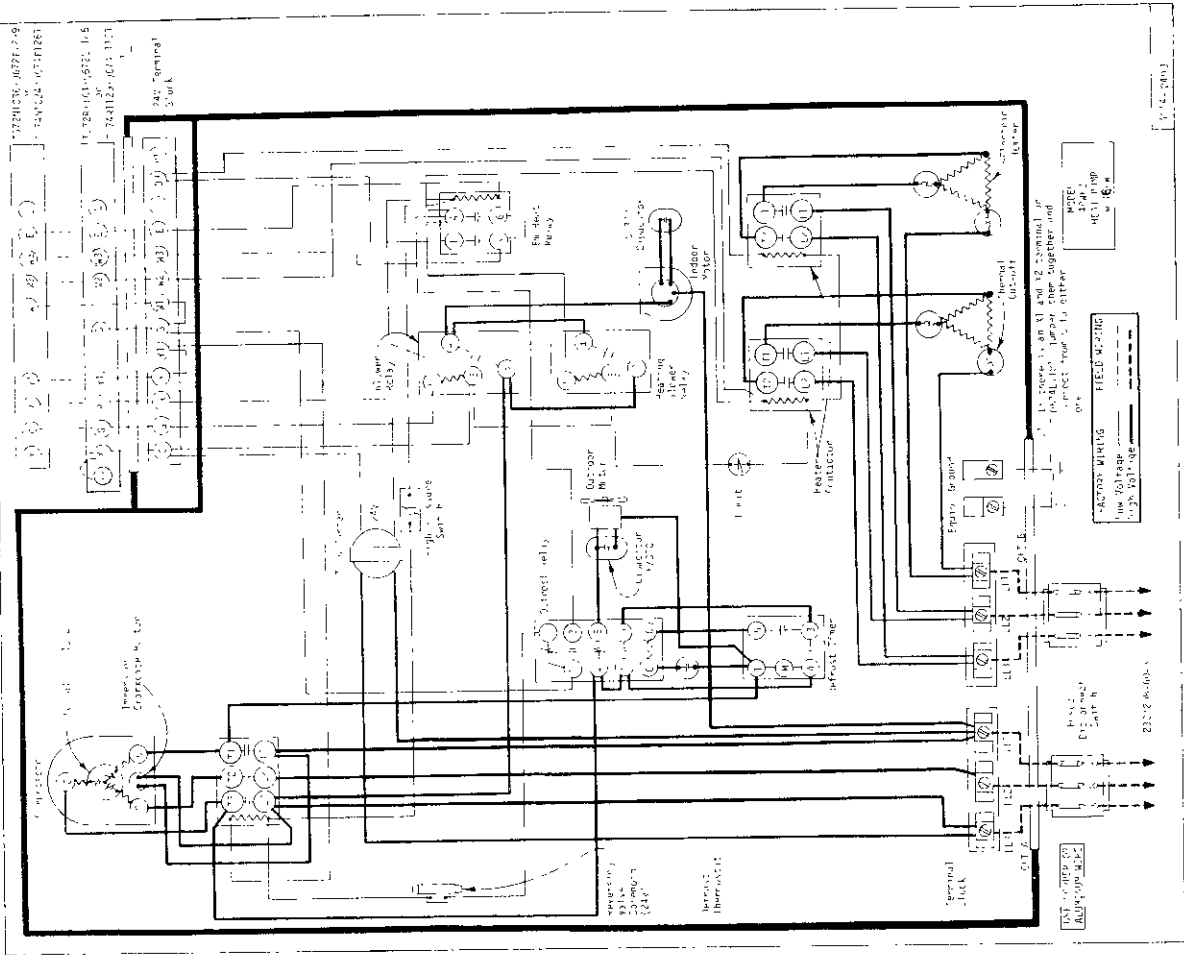
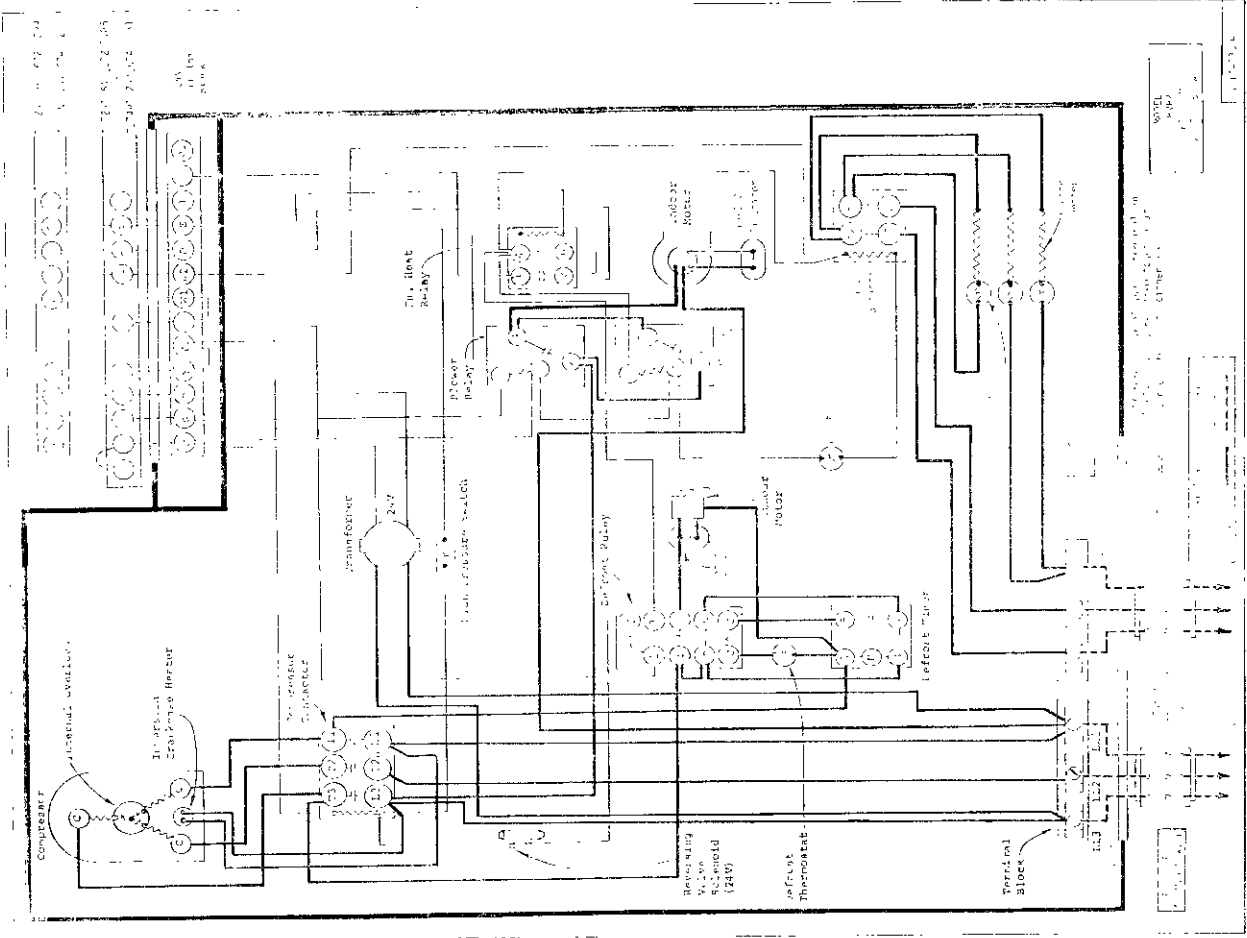

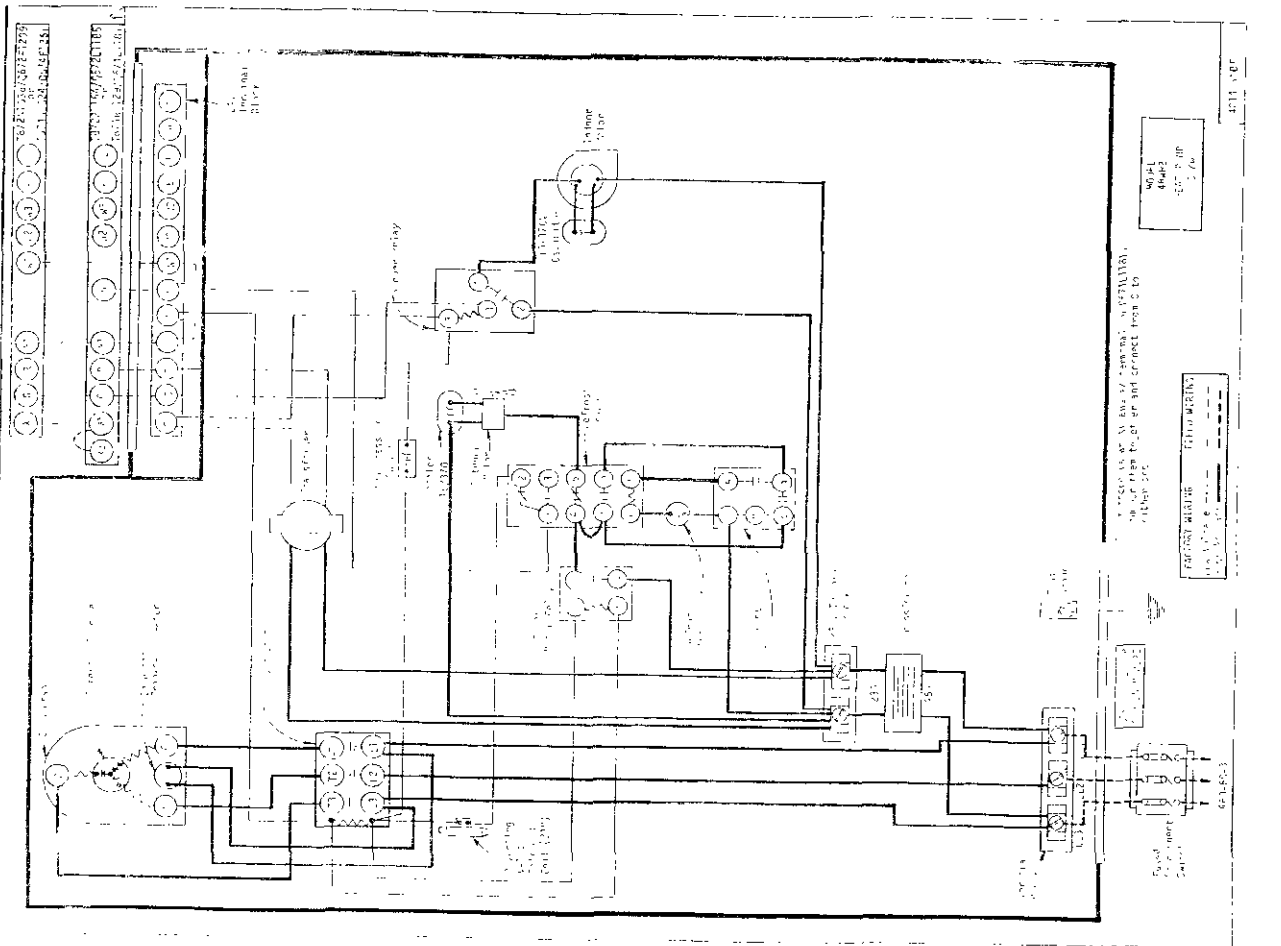
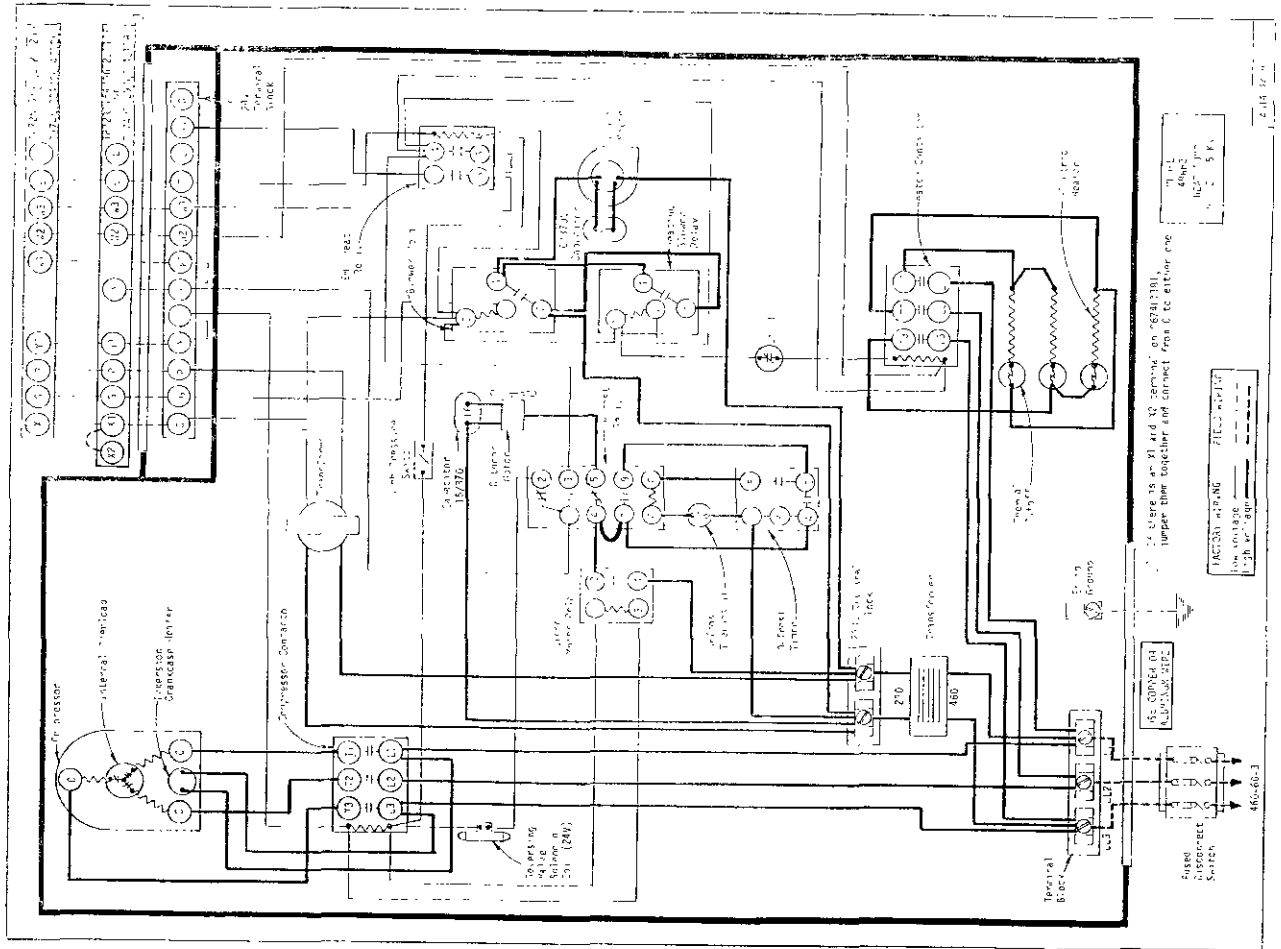

PARTS LIST  
SINGLE PACKAGE HEAT PUMPS

PART NO.	DESCRIPTION	48WH2	48MH2-3	48MH2-3 460V
5202-005	Accumulator	X	X	X
5152-026	Blower Housing	X	X	X
5152-011	Blower Wheel	X	X	X
5152-012	Blower Wheel	X	X	X
8552-036	Capacitor	X	X	X
8552-026	Capacitor	X	X	X
8552-005	Capacitor	X	X	X
5811-026	Capillary Tube - Heat	(2)	(2)	(2)
5811-021	Capillary Tube - Cool	(2)	(2)	(2)
5651-006	Check Valve	X	X	X
8000-067	Compressor	X	X	X
8000-030	Compressor	X	X	X
8000-047	Compressor	X	X	X
5051-029	Condenser Coil	X	X	X
8401-003	Contact - Comp. 30A	X	X	X
8401-002	Contact - Comp. 25A	X	X	X
8401-006	Contact - Heater 20A	X	X	X
8408-004	Defrost Mounting Plate	X	X	X
8408-002	Defrost Thermostat	X	X	X
5060-025	Evaporator Coil	X	X	X
5151-027	Fan Blade	X	X	X
7004-016	Filter	X	X	X
8614-007	Fuse - Heater 60A	X	X	X
8614-022	Fuse - Compressor 60A	X	X	X
8614-006	Fuse - 30A	X	X	X
8614-014	Fuse Block	X	X	X
8614-019	Fuse Block	X	X	X
8604-044	Heat Strip	X	X	X
8604-048	Heat Strip	X	X	X
8604-046	Heat Strip	X	X	X
8604-047	Heat Strip	X	X	X
8604-050	Heat Strip	X	X	X
8604-051	Heat Strip	X	X	X
8604-052	Heat Strip	X	X	X
8406-010	High Pressure Switch	X	X	X
8402-024	Limit Switch	X	X	X
8106-014	Motor - Blower	X	X	X
8105-021	Motor - Fan	X	X	X
8200-004	Motor Mount Fan	X	X	X
8201-008	Relay - Blower	X	X	X
8201-024	Relay - Compressor Fault	X	X	X
8201-023	Relay - Defrost	X	X	X
8201-013	Relay - Emergency Heat	X	X	X
5650-006	Reversing Valve	X	X	X
5650-008	Solenoid Coil	X	X	X
5210-005	Strainer	(2)	(2)	(2)
8607-010	Terminal Board 24V	X	X	X
8607-001	Terminal Block 230V	X	X	X
8607-002	Terminal Block 230V	X	X	X
8607-003	Terminal Block 230V	X	X	X
8402-032	Thermal Cutoff	X	X	X
8612-011	Timer	X	X	X
8407-015	Transformer	X	X	X
8407-004	Transformer - Stepdown	X	X	X
8401-010	Contact - 2P30A (12-15kw)	X	X	X

Minimum net billing \$15.00. Supersedes all previous lists.  
Subject to change without notice. F.O.B. Bryan, Ohio.

