

INSTALLATION INSTRUCTIONS

**WALL MOUNTED
PACKAGE HEAT PUMPS**

MODELS

42WH

48WH5

60WH

ELECTRICAL INFORMATION												WIRING INFORMATION**			
Model	Rated Volts/Ph	Operating Voltage Range	Heater* KW	Max Unit Amps	No. Field Power Circuits	Internal Fuses		Required Overcurrent Protection ①		Minimum Circuit Ampacity		Field Power Wiring		Ground Wire Size	
						Ckt. A	Ckt. B	Ckt. A	Ckt. B	Ckt. A	Ckt. B	Ckt. A	Ckt. B	Ckt. A	Ckt. B
42WH	230/208-1	197-253	0	29.3	1			50		35		8		10	
			5	50.1	1			70		61		8		8	
			10	71	1	50/30		90		87		2		8	
			15+	91.6	2	50/60		50	60	35	70	8	2	10	8
			20	87.2	2	50	60/30	50	110	35	100	8	1	10	8
42WH-3	230/208-3	187-253	0	21.8	1			40		28		10		10	
			9	43.5	1			60		48		6		10	
			12	58.7	1	40/60		60		62		8		10	
			15+	58.0	1	40/90		70		71		3		8	
			18	47.4	1	40/60		40		60		8		8	
42WH-3	460-3	414-506	0	10.4	1			15		15		14		14	
			9	21.2	1			30		24		10		10	
			12	24.8	1			30		30		10		10	
			15+	28.4	1			35		35		8		10	
			18	23.7	1			30		30		10		10	
48WH-3	230/208-3	187-253	0	24.8	1			45		30		8		10	
			9	46.5	1			60		58		8		8	
			12	53.7	1	45/30		70		67		8		8	
			15+	61.0	1	45/90		80		76		3		8	
			18	47.4	1	45/60		60		60		8		8	
48WH-3	460-3	414-506	0	12.4	1			20		15		14		14	
			9	23.2	1			30		29		10		10	
			12	26.8	1			35		33		10		10	
			15+	30.4	1			40		37		8		10	
			18	23.7	1			30		30		10		10	
60WH	230/208-1	197-253	0	37.3	1			60		45		6		10	
			5	58.1	1			90		71		3		8	
			10	75.0	1	60/30		110		97		1		6	
			15+	95.8	2	60/60		60	60	45	70	6	2	10	8
			20	67.2	2	60	60/60	60	110	45	100	6	1	10	6
60WH-3	230/208-3	187-253	0	26.1	1			50		32		8		10	
			9	48.8	1			70		59		8		8	
			12	55.2	1	50/30		80		68		8		8	
			15+	62.5	1	50/90		90		77		3		8	
			18	49.5	1	50/60		70		59		8		8	
60WH-3	460-3	414-506	0	13.4	1			25		16		12		12	
			9	24.2	1			35		34		10		10	
			12	27.8	1			40		34		8		10	
			15+	31.4	1			40		38		8		10	
			18	24.2	1			24.2		30		10		10	

*Electric heaters are nominal Kw @ 240 or 480V.

**Based on 50°C copper wire. Other wiring materials must be rated for marked minimum circuit ampacity or greater. Not all models are approved for aluminum wire.

① Time delay fuses or "HACR Type" circuit breakers must be used for 60 and smaller sizes. Standard fuses or circuit breakers suitable for sizes 70 and larger.

+ Maximum Kw that can operate with heat pump on.

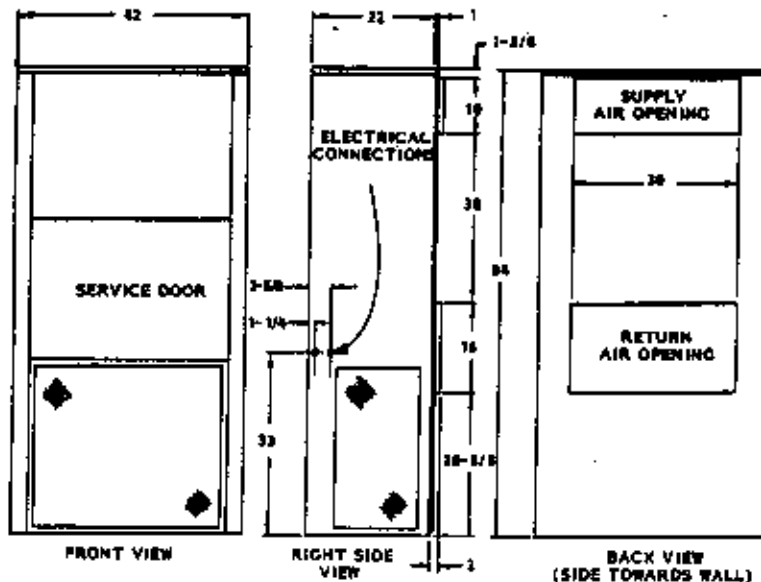

IMPORTANT

The equipment covered in this manual is to be installed by trained, experienced service and installation technicians. Any heat pump is more critical of proper operating, charge and an adequate duct system than a straight air conditioning unit. All duct work supply and return, must be properly sized for the design air flow requirement of the equipment. ACCA is an excellent guide to proper sizing. All duct work or portions thereof not in the conditioned space should be properly insulated in order to both conserve energy and prevent condensation or moisture damage.

SHIPPING DAMAGE

Upon receipt of equipment, the carton should be checked for external signs of shipping damage. If damage is found, the receiving party must contact the last carrier immediately, preferably in writing, requesting inspection by the carrier's agent.

GENERAL

The refrigerant system is completely assembled and charged. All internal wiring is complete.

The unit is designed for use with or without duct work. Flanges are provided for attaching the supply and return ducts.

These instructions explain the recommended method to install the air cooled self-contained unit and the electrical wiring connections to the unit.

These instructions and any instructions packaged with any separate equipment required to make up the entire air conditioning system should be carefully read before beginning the installation. Note particularly "Starting Procedure" and any tags and/or labels attached to the equipment.

While these instructions are intended as a general recommended guide, they do not supersede any national and/or local codes in any way. Authorities having jurisdiction should be consulted before the installation is made.

INSTALLATION

Size of unit for a proposed installation should be based on heat loss calculation made according to methods of Air Conditioning Contractors of America (ACCA). The air duct should be installed in accordance with the Standards of the National Fire Protection Association for the Installation of Air Conditioning and Ventilating systems of Other Than Residence Type, NFPA No. 90A, and Residence Type Warm Air Heating and Air Conditioning Systems, NFPA No. 90B. Where local regulations are at a variance with instructions, installer should adhere to local codes.

DUCT WORK

Design the duct work according to methods given by the Air Conditioning Contractors of America. When duct runs through unheated spaces, it should be insulated with a minimum of one inch of insulation. Use insulation with a vapor barrier on the outside of the insulation. Flexible joints should be used to connect the duct work to the equipment in order to keep the noise transmission to a minimum.

A one-inch clearance to combustible material for the first three feet of duct attached to the outlet air frame is required. See page 6 for further details.

FILTER

A one inch throwaway filter is supplied with each unit. The filter slides into position making it easy to service. This filter can be serviced from the outside by removing the service door.

FRESH AIR INTAKE

All units are built with a fresh air inlet hole punched in the service panel. The fresh air damper assembly is shipped with each unit, and must be attached at the installation site. See Figure 1 for typical installation procedure.

The fresh air damper assembly is standard equipment with the unit because of the variety of state or local codes requiring fresh air capability.

All capacity, efficiency and cost of operation information as required for Department of Energy "Energyguide" Fact Sheets is based upon the fresh air blank-off plate in place and is recommended for maximum energy efficiency.

The blank-off plate is available upon request from the factory and is installed in place of the fresh air damper shipped with each unit.

WALL MOUNTING

1. Two holes, the size of the supply and return air openings must be cut through the wall as shown in Figure 2.
2. On wood-frame walls, the wall construction must be strong and rigid enough to carry the weight of the unit without transmitting any unit vibration.
3. Concrete block walls must be thoroughly inspected to insure that they are capable of carrying the weight of the installing unit.
4. Ducts through the walls must be insulated and all joints taped or sealed to prevent air or moisture entering the wall cavity.
5. Some installations may not require any return air duct. It is recommended that on this type of installation that a filter grille be located in the wall. Filters must be of sufficient size to allow a maximum velocity of 400 FPM.

NOTE: If no return air duct is used, applicable insulation codes may limit this cabinet to installation only in a single story structure.

WIRING - MAIN POWER

Refer to the unit rating plate for wire sizing information and maximum fuse or "HACR Type" circuit breaker size. Each outdoor unit is marked with a "Minimum Circuit Ampacity." This means that the field wiring used must be sized to carry that amount of current. Depending on the installed Kw of electric heat, there may be two field power circuits required. If this is the case, the unit serial plate will so indicate. Some models are suitable only for connection with copper wire, while others can be wired with either copper or aluminum wire. Each unit and/or wiring diagram will be marked "Use Copper Conductors Only" or "Use Copper or Aluminum Conductors." These instructions MUST BE adhered to. Refer to the National Electrical Code for complete current carrying capacity data on the various insulation grades of wiring material.

The electrical data lists fuse and wire sizes (60°F copper) for all models, including the most commonly used heater sizes. Also shown are the number of field power circuits required for the various models with heaters.

The unit rating plate lists a "Maximum Time Delay Relay Fuse" or "HACR Type" circuit breaker that is to be used with the equipment. The correct size must be used for proper circuit protection and also to assure that there will be no nuisance tripping due to the momentary high starting current of the compressor motor.

WIRING - 24V CONTROL CIRCUIT

Nine (9) wires should be run from thermostat subbase to the 24V terminal board in the unit. A nine conductor, 18 gauge copper, color-coded thermostat cable is recommended. The connection points are shown on most of the wiring diagrams and are also shown below.

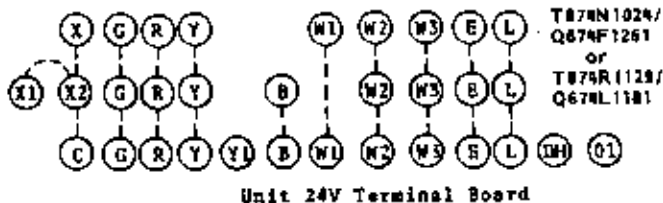

IMPORTANT NOTE: Only the thermostat and subbase combinations as shown above will work with this equipment. The stat and subbase **MUST** be matched, and correct operation can be assured only by proper selection and application of these parts.

CONDENSATE DRAIN

A plastic drain hose extends from the drain pan at the top of the unit down to the unit base. There are openings in the unit base for the drain hose to pass through. In the event the drain hose is connected to a drain system of some type, it must be an open or vented type system to assure proper drainage.

COMPRESSOR MALFUNCTION RELAY (Single Phase Models Only)

Actuation of the green "check" lamp is accomplished by a voltage type-relay which is factory installed. Any condition such as loss of charge, defective capacitor, defective contactor, etc., that will prevent compressor from operating will cause green lamp to activate. This is a signal to the operator of the equipment to place system in emergency heat position.

PRESSURE SERVICE PORTS

High and low pressure service ports are installed on all units so that the system operating pressures can be observed. Pressure curves can be found later in the manual covering all models on both cooling and heating cycles. It is imperative to match the correct pressure curve to the unit by model number.

SEQUENCE OF OPERATION

Cooling - Circuit R-Y makes at thermostat pulling in compressor contactor, starting the compressor and outdoor motor. The G (indoor motor) circuit is automatically completed on any call for cooling operation, or can be energized by manual fan switch on subbase for constant air circulation.

Heating - A 24V solenoid coil on reversing valve controls heating cycle operation. Two thermostat options, one allowing "Auto" changeover from cycle to cycle and the other constantly energizing solenoid coil during heating season and thus eliminating pressure equalization noise except during defrost, are to be used. On "Auto" option, a circuit is completed from R-W1 and R-Y on each heating "on" cycle, energizing reversing valve solenoid and pulling in compressor contactor starting compressor and outdoor motor. R-G also make starting indoor blower motor. Heat pump heating cycle now in operation. The second option has no "Auto" changeover position, but instead energizes the reversing valve solenoid constantly whenever the system switch on subbase is placed in "Heat" position, the "B" terminal being constantly energized from R. A thermostat demand for heat completes R-Y circuit, pulling in compressor contactor starting compressor and outdoor motor. R-G also make starting indoor blower motor.

COMPRESSOR CUT-OFF THERMOSTAT & OUTDOOR THERMOSTATS

Heat pump compressor operation at outdoor temperatures below 0°F are neither desirable nor advantageous in terms of efficiency. Since most equipment at time of manufacture is not designated for any specific destination of the country, and most of the equipment is installed in areas not approaching the lower outdoor temperature range, the compressor cut-offs are not factory installed.

Outdoor thermostats are available to hold off various banks of electric heat until needed as determined by outdoor temperature. The set point of either type of thermostat is variable with geographic region and sizing of the heating equipment to the structure. Utilization of the Heating Application Data and the heat loss calculation of the building are useful in determining the correct set points.

COMPRESSOR CUT-OFF AND OUTDOOR THERMOSTAT WIRING

See specific wiring information on page 7.

HEAT ANTICIPATION

Both of the thermostats shown below have a fixed heat anticipator for stage 1 with no adjustment required. Stage 2 has an adjustable anticipator for the W2 connection and fixed for the W3 connection. Both the W2 and W3 circuits are controlled by the stage 2 bulb. The only heat anticipator that needs to be checked is stage 2 and it should be set to match the load carried by the W2 circuit. The normal factory wiring provides for only one electric heat contactor to be controlled by W2, and the anticipator should be set at .40A. If special field wiring is done, it is best to actually measure the load but a good rule is .40A for each heat contactor controlled by W2.

WALL THERMOSTAT AND SUBBASE COMBINATIONS			
Group	Thermostat	Subbase	Predominant Feature
A	8903-017 (T879R1129)	8488-809 (Q679L1181)	Heat or Cool No Auto ①
B	8903-018 (T879N1029)	8404-018 (Q679F1261)	Automatic Heat-Cool Changeover Position ②

① No automatic changeover position--must manually place in heat or cool. Reversing valve remains energized at all times system switch is in heat position (except during defrost cycle). No pressure equalization noise when thermostat is satisfied on either heating or cooling.

② Allows thermostat to control both heating and cooling operation when set in "AUTO" position. Reversing valve de-energizes at end of each "ON" heating cycle.

IMPORTANT NOTE: Both thermostat and subbase combinations shown above incorporate the following features: Man-Auto fan switch, Off-Heat-Cool-Em. Heat Switch, and two (2) indicator lamps—one for emergency heat and one for compressor malfunction.

THERMOSTAT INDICATOR LAMPS

The red lamp marked "EM.HT." comes on and stays on whenever the system switch is placed in the emergency heat position. The green lamp marked "check" will come on if there is any problem that prevents the compressor from running when it is supposed to be.

EMERGENCY HEAT POSITION

The operator of the equipment must manually place the system switch in this position. This is done when there is a known problem with the indoor section, or when the green "check" lamp comes on indicating a problem.

DEFROST CYCLE

The defrost cycle is controlled by time and temperature. The 24 volt timer motor runs all the time the compressor is in operation. When the outdoor temperature is in the lower 40°F temperature range or colder, the outdoor coil temperature is 32°F or below. This temperature is sensed by the defrost thermostat mounted near the bottom of the outdoor coil on a return bend. The defrost thermostat closes at approximately 32°F. Every 60 (or 30) minutes that the compressor is running, contacts 3-5 close for 7 minutes, with contacts 3-4 closed for the first 40 seconds of that 7 minutes. If the defrost thermostat is closed, the defrost relay energizes and places the system in defrost mode. An interlocking circuit is created with timer contacts 3-5 and defrost relay contacts 7-9 in series.

During the defrost mode, the refrigerant cycle switches back to the cooling cycle, the outdoor motor stops, electric heaters are energized, and hot gas passing through the outdoor coil melts any accumulated frost. When the temperature rises to approximately 57°F, the defrost thermostat opens, de-energizing the defrost relay and returning the system to heating operation.

If some abnormal or temporary condition such as a high wind causes the heat pump to have a prolonged defrost cycle, contacts 3-5 of the defrost timer will open after 7 minutes and restore the system to heating operations automatically.

There are two time settings on the defrost timer--30 minutes and 60 minutes. Most models are shipped wired on the 60 minute setting for greatest operating economy. If special circumstances require a change to the shorter time, remove wire connected to terminal 5/60 and reconnect to terminal 5/30.

There is a manual advance knob located on the timer. This can be used to advance timer to contact closure point if it is desired to check out defrost cycle operation, without waiting for time to elapse.

DEFROST TIMER WIRING

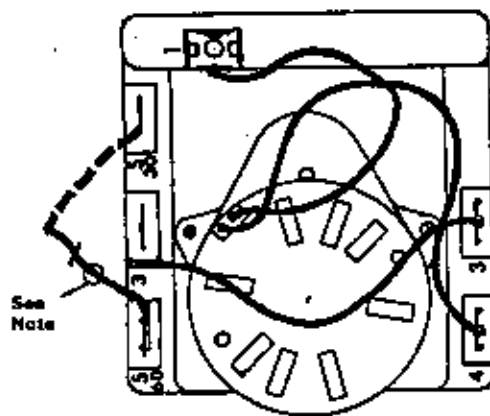

NOTE: All models are connected to 5/60 terminal (60 minutes). Any model can be changed from 60 minutes to 30 minutes by unplugging from 5/60 terminal and reconnecting to 5/30 terminal as shown by dotted line.

SERVICE HINTS

1. Caution homeowner to maintain clean air filters at all times. Also, not to needlessly close off supply and return air registers. This reduces air flow through the system, which shortens equipment service life as well as increasing operating costs.
2. Switching to heating cycle at 75°F or higher outside temperature may cause a nuisance trip of the manual reset high pressure switch.
3. The heat pump wall thermostats perform multiple functions. Be sure that all function switches are correctly set for the desired operating mode before trying to diagnose any reported service problems.

4. Check all power fuses or circuit breakers to be sure that they are the correct rating.
5. Periodic cleaning of the outdoor coil to permit full and unrestricted airflow circulation is essential.

IMPORTANT INSTALLER NOTE

For improved start-up performance wash the indoor coil with a dishwasher detergent.

CRANKCASE HEATERS

All units are provided with some form of compressor crankcase heat. Some single phase units utilize the compressor motor start winding in series with a portion of the run capacitor to generate heat within the compressor shell to prevent liquid refrigerant migration.

Some three phase units utilize a wraparound type of crankcase heater that warms the compressor oil from the outside.

Some single and three phase models have an insertion well-type heater located in the lower section of the compressor housing. This is a self-regulating type heater that draws only enough power to maintain the compressor at a safe temperature.

Some form of crankcase heat is essential to prevent liquid refrigerant from migrating to the compressor, causing oil pump out on compressor start-up and possible valve failure due to compressing a liquid.

Refer to unit wiring diagram to find exact type of crankcase heater used.

The following decal is affixed to all outdoor units detailing start-up procedure. This is very important. Please read carefully.

IMPORTANT

THESE PROCEDURES MUST BE FOLLOWED AT INITIAL START-UP AND AT ANY TIME POWER HAS BEEN REMOVED FOR 12 HOURS OR LONGER.

TO PREVENT COMPRESSOR DAMAGE WHICH MAY RESULT FROM THE PRESENCE OF LIQUID REFRIGERANT IN THE COMPRESSOR CRANKCASE.

1. MAKE CERTAIN THE ROOM THERMO STAT IS IN THE "OFF" POSITION (THE COMPRESSOR IS NOT TO OPERATE).

2. APPLY POWER BY CLOSING THE SYSTEM DISCONNECT SWITCH THIS ENERGIZES THE COMPRESSOR HEATER WHICH EVAPORATES THE LIQUID REFRIGERANT IN THE CRANKCASE.

3. ALLOW 4 HOURS OR 60 MINUTES PER POUND OF REFRIGERANT IN THE SYSTEM AS NOTED ON THE UNIT RATING PLATE WHOEVER IS GREATER.

4. AFTER PROPERLY ELAPSED TIME THE THERMOSTAT MAY BE SET TO OPERATE THE COMPRESSOR.

5. EXCEPT AS REQUIRED FOR SAFETY WHILE SERVICING - DO NOT OPERATE SYSTEM DISCONNECT SWITCH.

7981 061

NOTE:

If this unit is operated in cooling below a 65° outdoor ambient temperature, the installation of low ambient controls (LAC-1 and 8201-008 relay) to unit is required.

UNIT MODELS

20WA1
20WA4
18WH4
24WH4

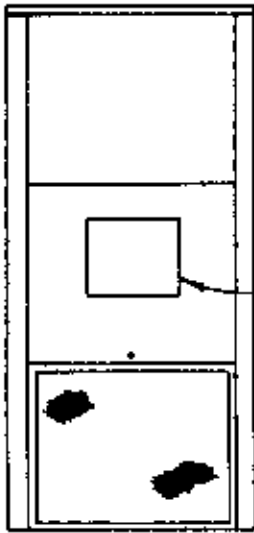

Model FAD10
Fresh Air Cover
With Adjustable
Damper

UNIT MODELS

30WA4
36WA5
30WH4
36WH5
42WA
42WH
48WA
48WH5
60WA
60WH

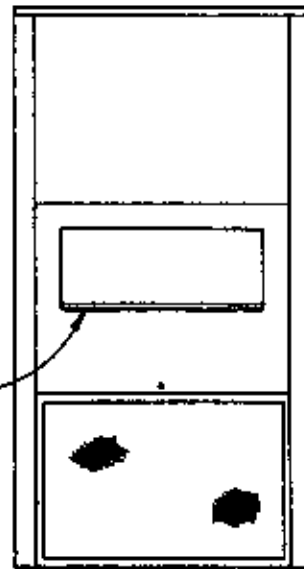

MODEL FAD25
Fresh Air Cover
With Adjustable
Damper

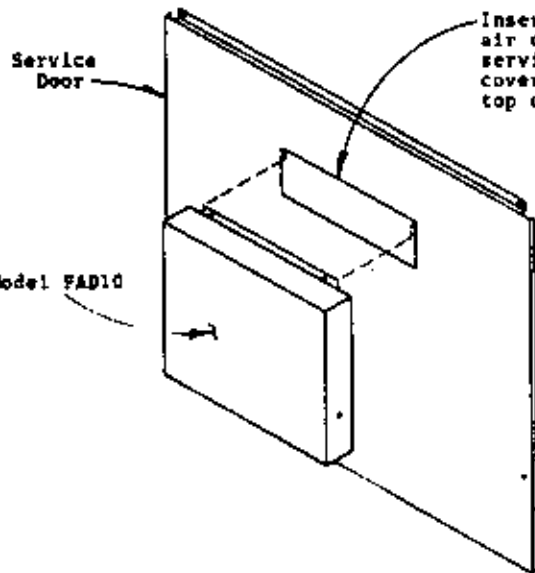

Insert top flange of fresh
air cover into opening in
service door and push top of
cover assembly all the way to
top of opening.

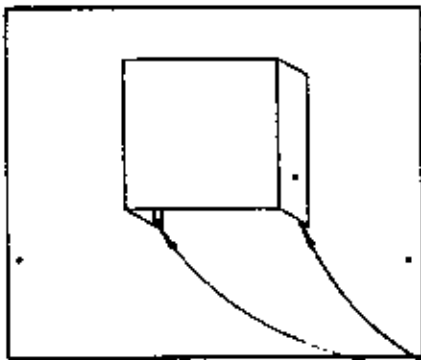
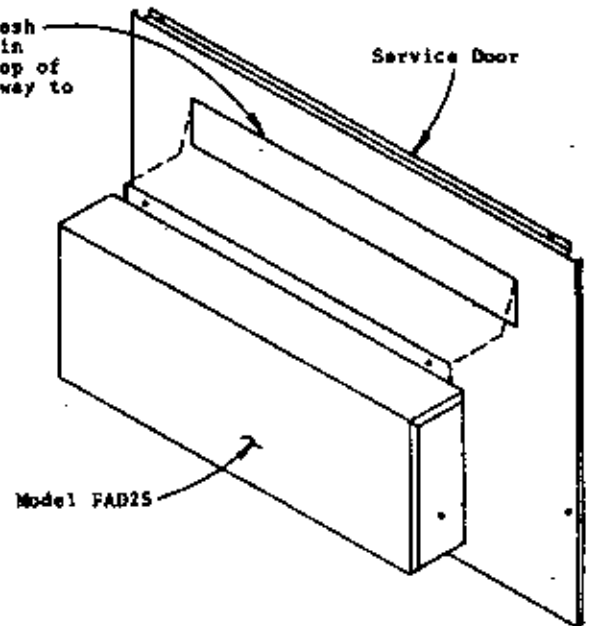

Secure bottom of
Fresh Air Cover Assembly
with two screws.

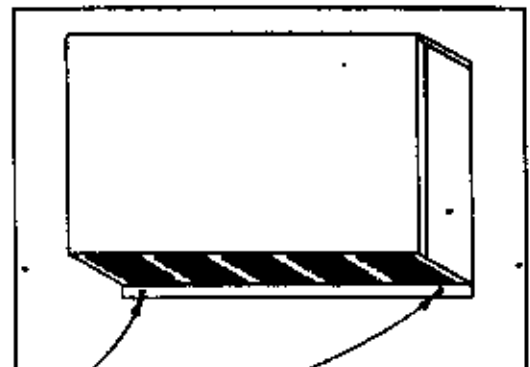
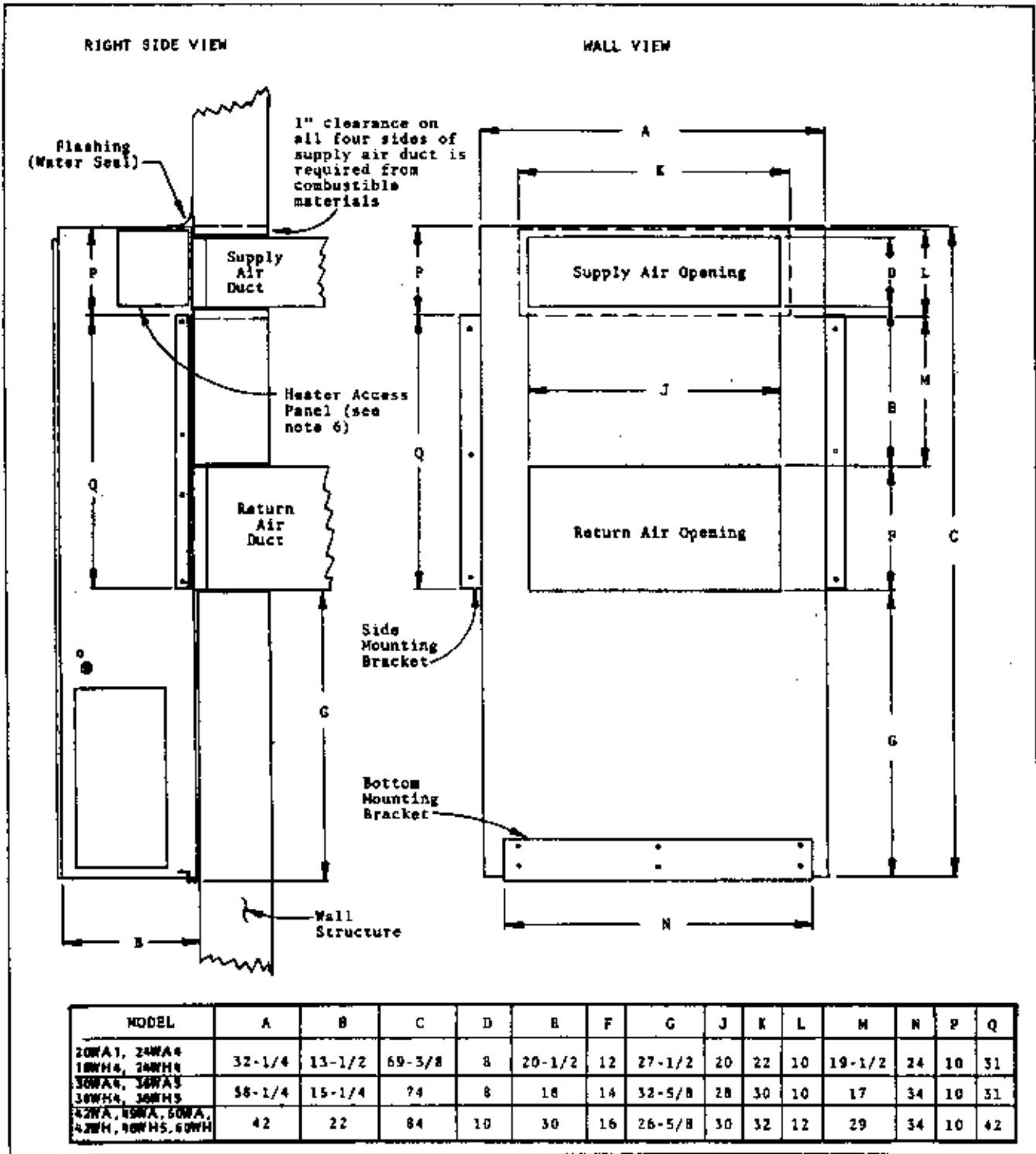

FIGURE 1

FIGURE 2



MOUNTING INSTRUCTIONS

1. These units are secured by wall mounting brackets which secure the unit to the outside wall surface at both sides and at the bottom.
2. The unit itself is suitable for "8" inch clearance, but the supply air duct flange and the first few feet of supply air duct require 1 inch clearance to combustible material. If combustible wall, use K and L dimensions for sizing. If non-combustible, use D and J.
3. After the wall opening positions have been selected, lay out the position for the bottom and side brackets. Fasten the brackets securely to the wall (type of fasteners will depend on wall construction).
4. Be sure to observe the P dimension when attaching the side brackets. This will assure that no screws are driven into the unit sides damaging any internal parts. One-half inch sheet metal screws are recommended.
5. For additional mounting rigidity, the return air and supply air (depending upon wall construction) frames or collars can be drilled and screwed or welded to the structural wall itself. Be sure to observe required clearance if combustible wall.
6. Maintain 30 inches minimum clearance on right side of unit to allow access to heat strip.

FAN BLADE SETTING DIMENSIONS

Shown in the drawing below are the correct fan blade setting dimensions for proper air delivery across the outdoor coil.

Any service work requiring removal or adjustment in the fan and/or motor area will require that the dimensions below be checked and blade adjusted in or out on the motor shaft accordingly.

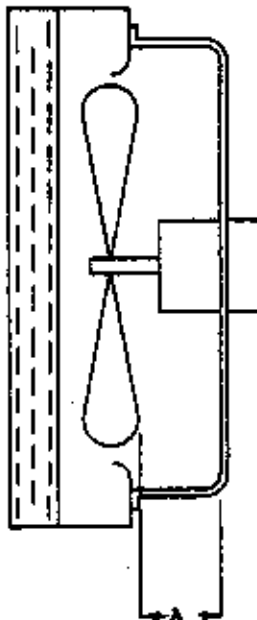

MODEL	DIM. A
42WH	1
48WH5	1
60WH	1-1/2

REFRIGERANT CHARGE

The correct system R-22 charge is shown on the unit rating plate. Optimum unit performance will occur with a refrigerant charge resulting in a suction line temperature (6" from compressor) as shown in the following table:

Model	Rated Airflow	95°F OD Temp.	82°F OD Temp.
42WH	1800	65 - 67	71 - 73
48WH5	1850	58 - 61	67 - 69
60WH	1760	51 - 53	63 - 65

The above suction line temperatures are based upon 80°F dry bulb/67°F wet bulb (88% R.H.) temperature and rated airflow across the evaporator during cooling cycle.

INDOOR BLOWER PERFORMANCE CFM—DRY COIL WITH FILTER			
E.S.P. In. H ₂ O	42WH	48WH5	60WH
.0	1998	2000	2020
.1	1910	1875	1915
.2	1825	1760	1810
.3	1720	1635	1700
.4	1595	1460	1560
.5	1440	1280	1415

RATED CFM AND E.S.P. (WET COIL—COOLING)			
Model	Rated CFM	Rated E.S.P.	Recommended Airflow Range
42WH	1800	.30	1440 - 1770
48WH5	1850	.33	1440 - 1770
60WH	1760	.20	1500 - 1940

COMPRESSOR CUT-OFF AND OUTDOOR THERMOSTAT WIRING

5,10,15Kw 1-PH — 9,12,15Kw 3-PH

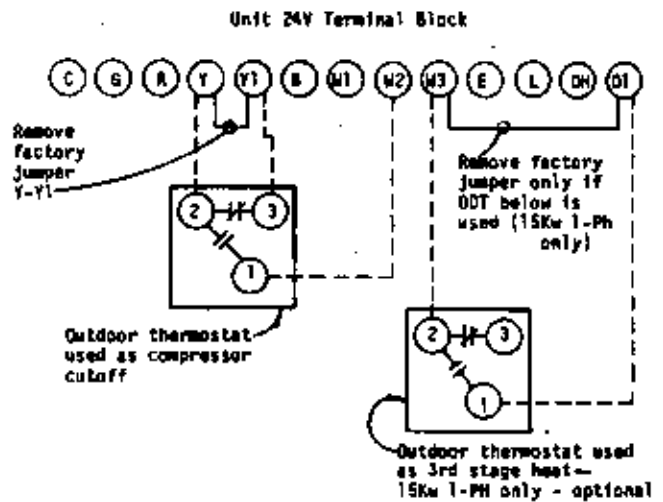

20Kw 1-PH — 18Kw 3-PH

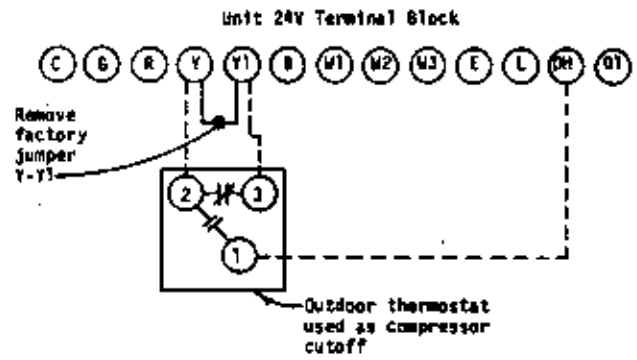

PACKAGED HEAT PUMP MODEL 42WH

ing curves are based upon 80DB, 67WB Temp. and d
 C (airflow) across the evaporator coil and should be J
 for reference purposes only. Specific information can be found
 under section titled "Refrigerant Charge" elsewhere in manual.
 If there is any doubt as to correct operating charge being in the
 system, the charge should be removed, system evacuated, and
 recharged according to serial plate instructions. Heating curves
 are based on 75DB in. H₂O. Refrigerant: R-22.

LOW SIDE PRESSURE--PSIG
 (SUCTION LINE)

HIGH SIDE (DISCHARGE LINE) PRESSURE--PSIG

0 10 20 30 40 50 60 70 80 90 100 110 120
 AIR TEMPERATURE ENTERING OUTDOOR COIL--DEGREE F.

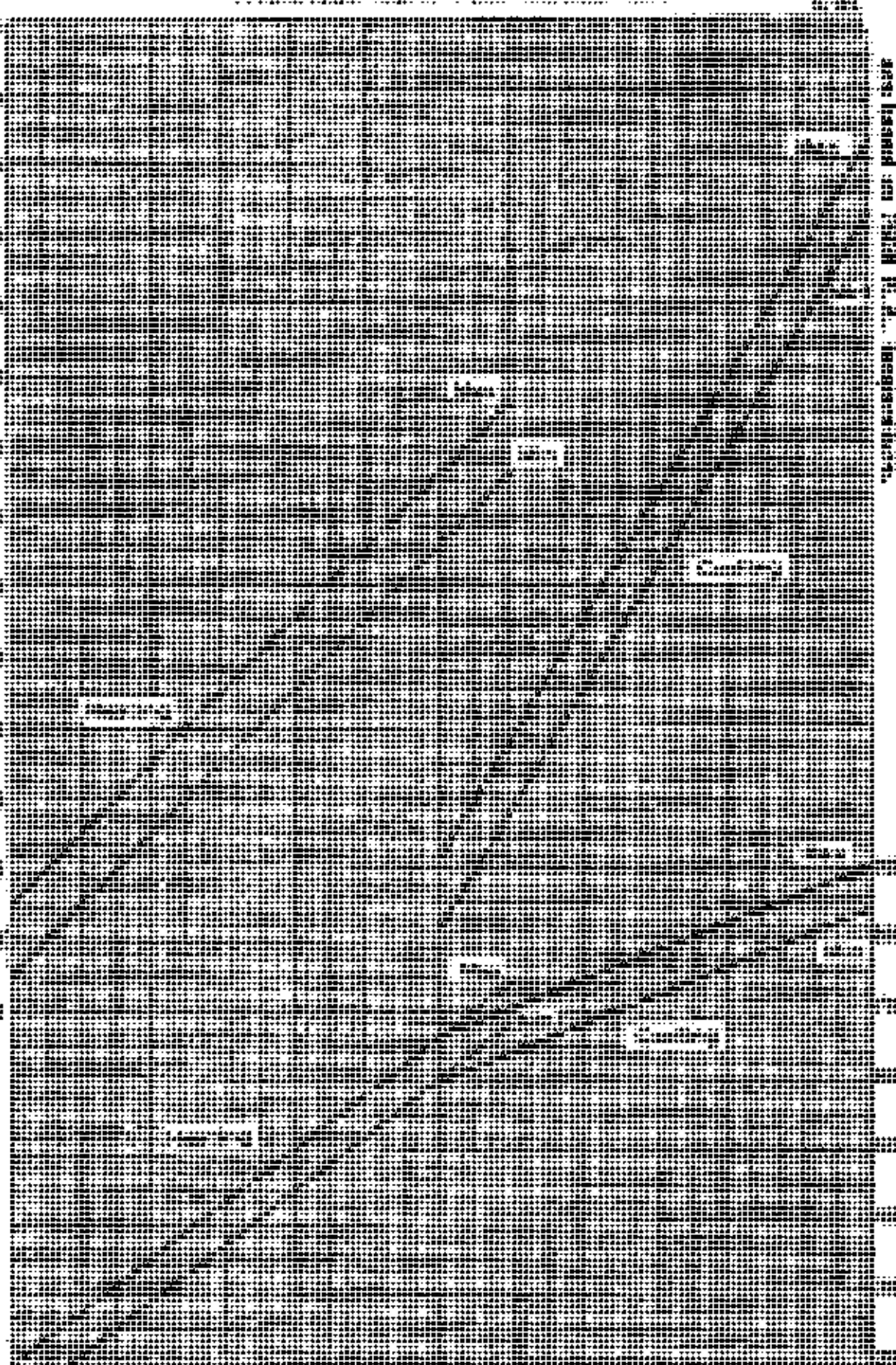

PACKAGED HEAT PUMP MODEL 48WH5

8/84

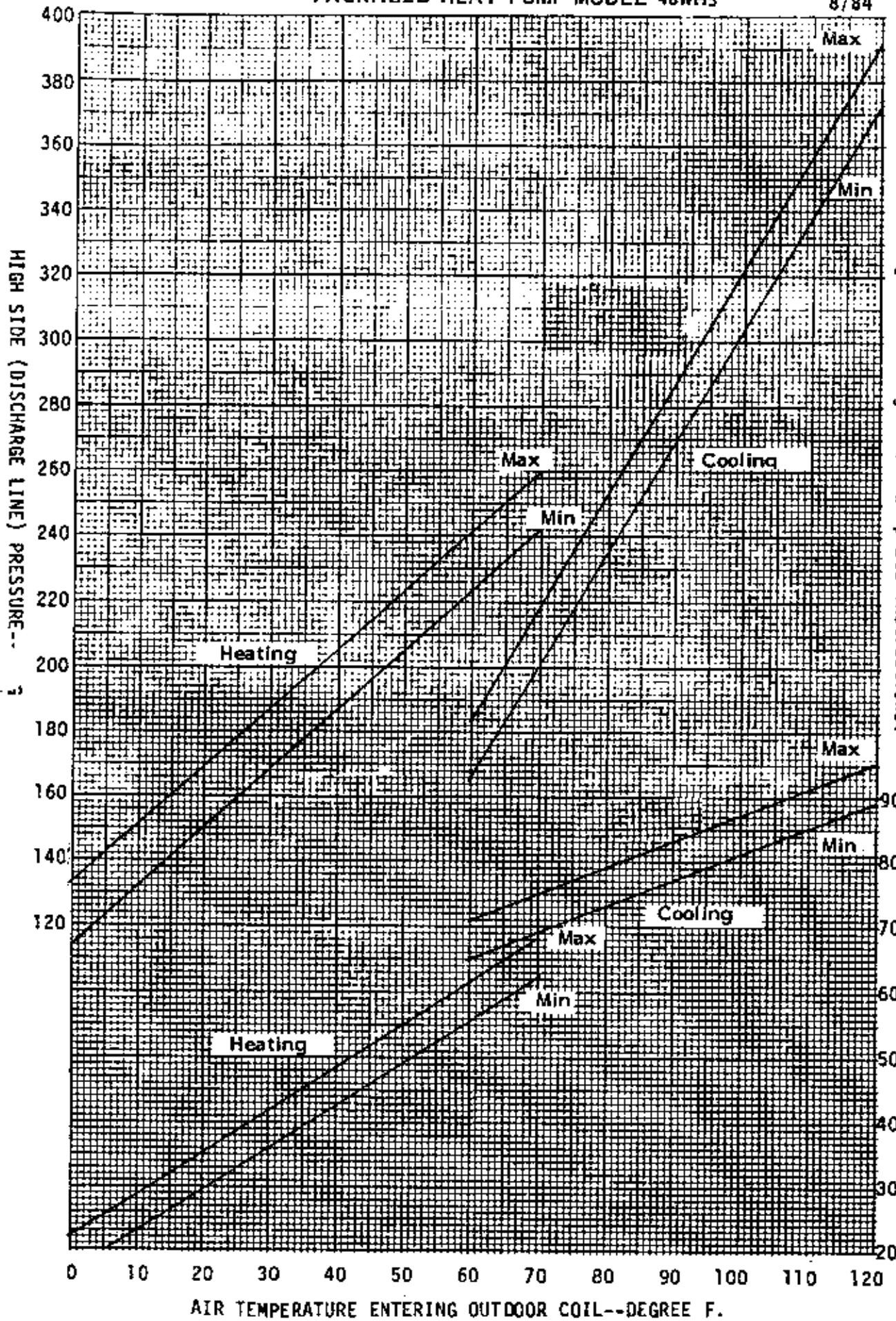

These curves are based upon 80°DB, 67°WB R.A. Temp. and Rated CFM (air-flow) across the evaporator coil and should be used for reference purposes only. Special information can be found under section titled "Refrigerant Charge" elsewhere in manual. If there is any doubt as to correct operating charge being in the system, the charge should be removed, system evacuated, and recharged according to serial plate instructions.

LOW SIDE PRESSURE--PSIG
(SUCTION LINE)

C. Capacity curves are based upon 80DB, 67WB Temp. and 1
 C. (airflow) across the evaporator coil and should be used
 for reference purposes only. Specific information can be found
 under section titled "Refrigerant Charge" elsewhere in manual.
 If there is any change in the condensing pressure rating in this
 system, then always consult the condensing pressure performance chart
 manufacturer's literature in order to determine the correct capacity
 and capacity correction factors.

LOW SIDE PRESSURE--PSIG
 100 90 80 70 60 50 40 30 20 10 0

HIGH SIDE (DISCHARGE LINE) PRESSURE--PSIG
 120 110 100 90 80 70 60 50 40 30 20 10 0

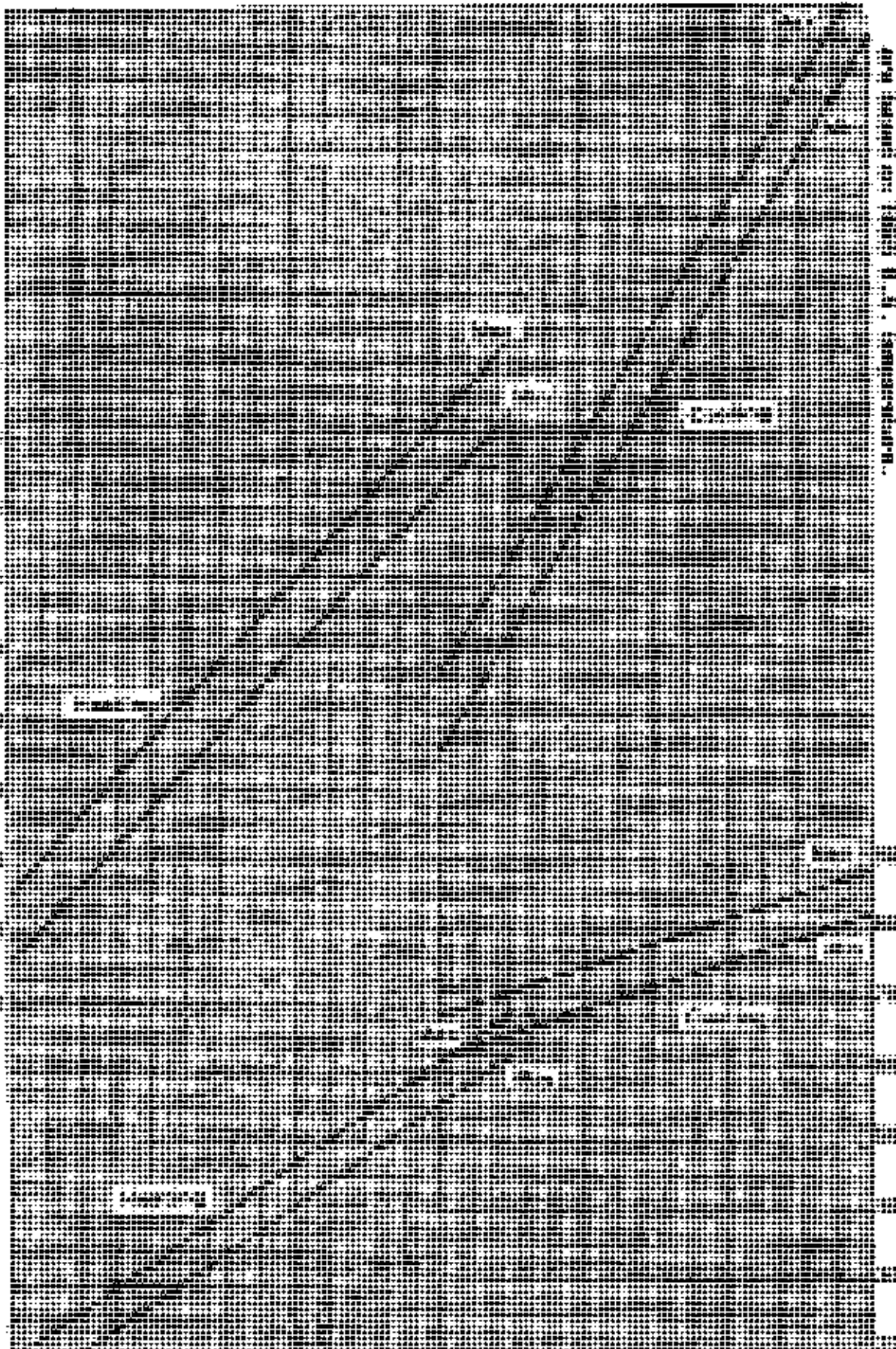

0 10 20 30 40 50 60 70 80 90 100 110 120
 AIR TEMPERATURE ENTERING OUTDOOR COIL--DEGREE F.

**PARTS LIST
SINGLE PACKAGE HEAT PUMPS**

7/85

Part No.	Description	42WH	42WH-3	48WH5	48WH5-3	60WH	60WH-3	42WH-3 460V	48WH5-3 460V	60WH-3 460V
5202-005	Accumulator	x	x	x	x			x	x	
5202-010	Accumulator					x	x			x
5152-026	Blower Housing 10-8	x	x	x	x	x	x	x	x	x
5152-011	Blower Wheel DD10-8A	x	x	x	x	x	x	x	x	x
5152-012	Blower Wheel DD10-8A	x	x	x	x	x	x	x	x	x
8552-030	Capacitor 40/440V	x		x						
8552-026	Capacitor 15/370V	x	x	x	x	x	x	x	x	x
8552-005	Capacitor 10/370V	x	x	x	x	x	x	x	x	x
8552-043	Capacitor 45/370V					x				
5811-026	Capillary Tube - Heat			(2)	(2)				(2)	
5811-021	Capillary Tube - Cool			(2)	(2)				(2)	
5811-017	Capillary Tube - Heat	(2)	(2)					(2)		
5811-033	Capillary Tube - Cool	(3)	(3)					(3)		
5811-036	Capillary Tube - Heat					(4)	(4)			(4)
5811-025	Capillary Tube - Cool					(2)	(2)			(2)
5651-036	Check Valve	x	x	x	x	x	x	x	x	x
8000-072	Compressor AV144ET	x								
8000-088	Compressor AV145RT		x							
8000-081	Compressor AV168ET			x						
8000-082	Compressor AV169RT				x					
8000-074	Compressor AG134ET					x				
8000-075	Compressor AG134RT						x			
8000-089	Compressor AV145TT						x			
8000-083	Compressor AV169TT								x	
8000-049	Compressor AG133UT									x
5051-029	Condenser Coil	x	x	x	x			x	x	
5051-038	Condenser Coil					x	x			x
8401-003	Contacto - Comp. 30A	x		x						
8401-002	Contacto - Comp. 25A		x		x			x	x	x
8401-006	Contacto - Heater 20A	x	x	x	x	x	x			
8401-010	Contacto - 2P30A (12-15Kw)		x		x		x			
8401-011	Contacto 3P30A						x			
8401-016	Contacto 1P35A					x				
8408-004	Defrost Mounting Plate	x	x	x	x	x	x	x	x	x
8408-012	Defrost Thermostat	x	x	x	x	x	x	x	x	x
5060-036	Evaporator Coil	x	x					x		
5060-025	Evaporator Coil			x	x				x	
5060-039	Evaporator Coil					x	x			x
5151-027	Fan Blade F12H9.5-2430	x	x	x	x	x	x	x	x	x
7004-016	Filter 26x30	x	x	x	x	x	x	x	x	x
8614-022	Fuse TR60			x		x				
8614-007	Fuse 60A	x	x	x	x	x	x			
8614-006	Fuse 30A	x	x	x	x	x	x			
8614-033	Fuse OT45		x		x		x			
8614-023	Fuse TR50	x	x		x	x	x			
8614-032	Fuse OT40		x		x		x			
8614-018	Fuse Block 10Kw	x		x		x				
8614-014	Fuse Block 15Kw	x		x		x				
8614-037	Fuse TR40		x							

**PARTS LIST
SINGLE PACKAGE HEAT PUMPS**

9/85

Part No.	Description	42WH	42WH-3	48WH5	48WH5-3	60WH	60WH-3	42WH-3 460V	48WH5-3 460V	60WH-3 460V
8614-019	Fuse Block 15Kw	x	x	x	x	x	x			
8614-021	Fuse Block 9Kw		x		x		x			
8614-020	Fuse Block 12, 15, 18Kw		x		x		x			
8604-044	Heat Strip 10Kw	x		x		x				
8604-048	Heat Strip 9Kw		x		x		x			
8604-046	Heat Strip 12Kw		x		x		x			
8604-047	Heat Strip 15Kw	x	x	x	x	x				
8604-050	Heat Strip 9Kw							x	x	x
8604-051	Heat Strip 12Kw							x	x	x
8604-052	Heat Strip 15Kw							x	x	x
8406-010	High Pressure Switch	x	x	x	x	x	x	x	x	x
8402-047	Limit Switch L180-7	x	x	x	x	x	x	x	x	x
8106-014	Blower Motor 1/2 hp	x	x	x	x	x	x	x	x	x
8105-021	Motor - Fan 1/3 hp	x	x	x	x	x	x	x	x	x
8200-004	Motor Mount Fan	x	x	x	x	x	x	x	x	x
8201-008	Relay - Blower	x	x	x	x	x	x	x	x	x
8201-024	Relay - Compressor Fault	x		x		x				
8201-047	Relay - Defrost	x	x	x	x	x	x	x	x	x
8201-013	Relay - Emergency Heat	x	x	x	x	x	x	x	x	x
5650-006	Reversing Valve	x	x	x	x	x	x	x	x	x
5650-008	Solenoid Coil	x	x	x	x	x	x	x	x	x
5210-005	Strainer	x	x	(2)	(2)	x	x	x	(2)	x
5210-009	Strainer	x	x					x		
5210-006	Strainer					x	x			x
8607-015	Penolic Insulator							x	x	x
8607-010	Terminal Board 24V	x	x	x	x	x	x	x	x	x
8607-013	Terminal Block 230V	x		x		x				
8607-014	Terminal Block 230V		x		x		x	x	x	x
8402-032	Thermal Cutoff	x	x	x	x	x	x	x	x	x
8612-012	Timer	x	x	x	x	x	x	x	x	x
8407-035	Transformer	x	x	x	x	x	x	x	x	x
8407-004	Transformer - Stepdown							x	x	x
8607-017	Terminal block							x	x	x

Minimum net billing \$15.00. Supersedes all previous lists. Subject to change without notice.

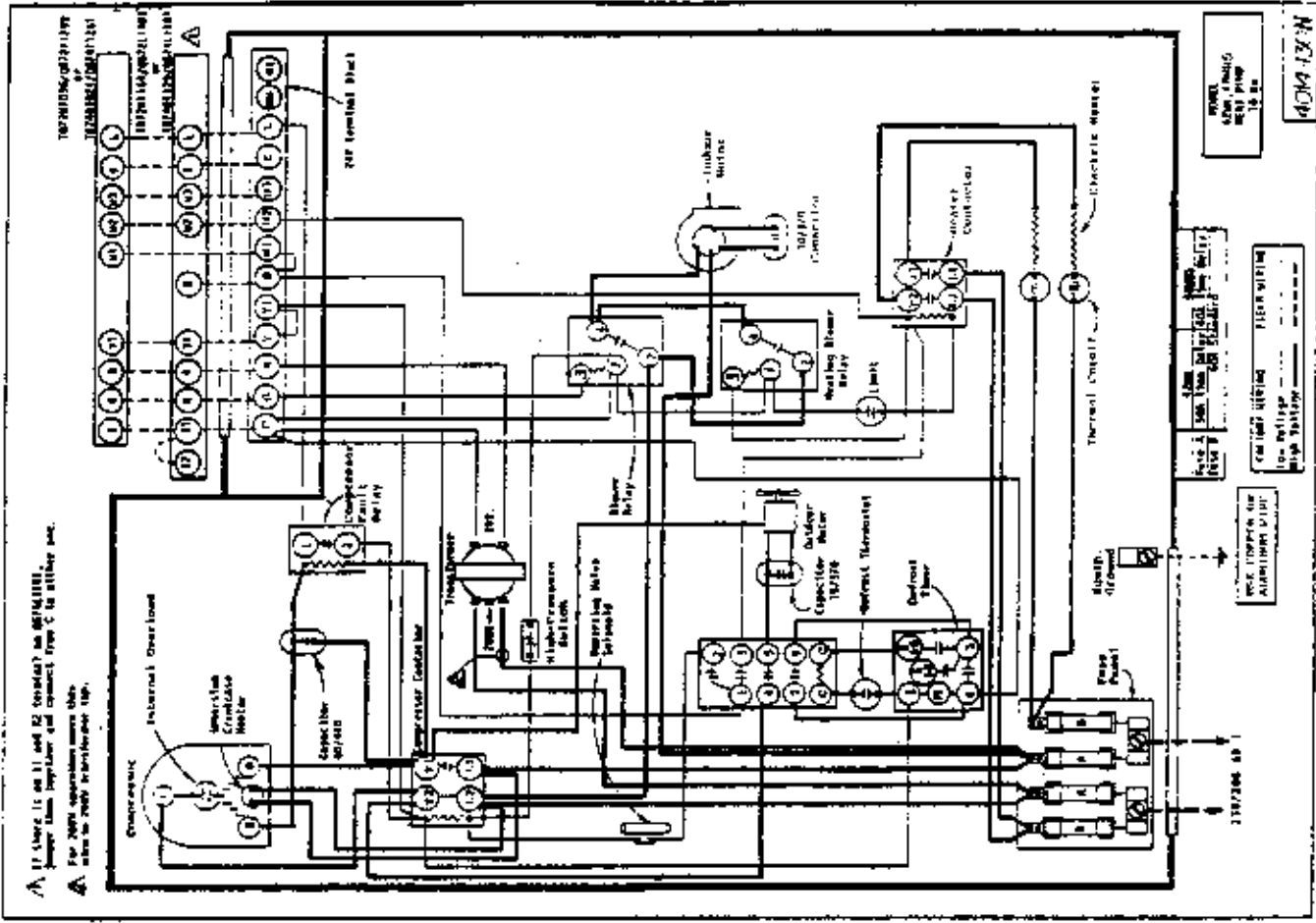

WIRE TAPING
MAY BE
USED

WIRE TAPING
MAY BE
USED

WIRE TAPING
MAY BE
USED

WIRE TAPING
MAY BE
USED

WIRE TAPING
MAY BE
USED

WIRE TAPING
MAY BE
USED

WIRE TAPING
MAY BE
USED

WIRE TAPING
MAY BE
USED

WIRE TAPING
MAY BE
USED

404-122

404-122

404-122

404-122

▲ If there is an RT and RT Control, see 0404131C
 Jumper Lead Together and Connect from E to either one.
 ▲ For 200V operation, connect this
 wire to 200V transformer tap.

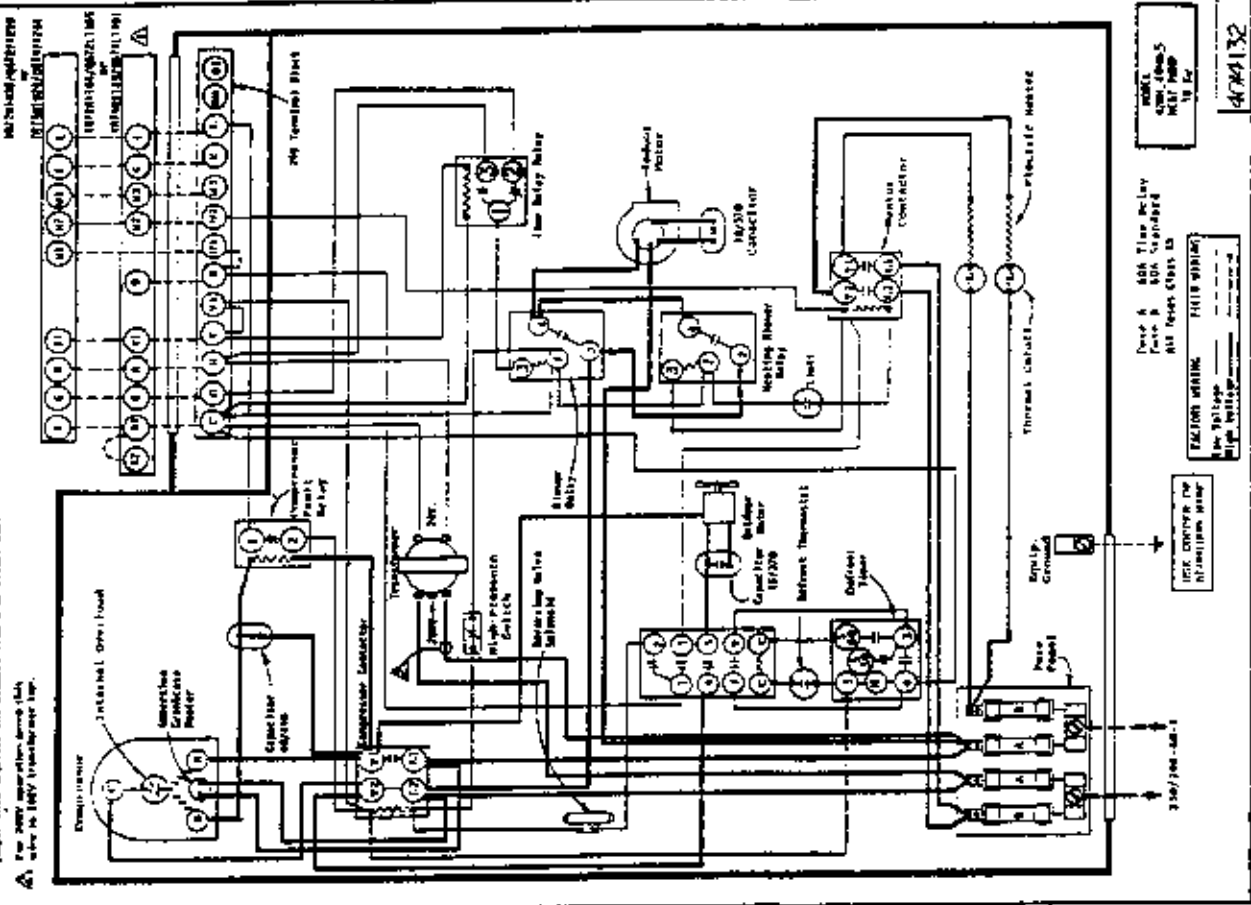

FACTORY WIRING
 Low Voltage
 High Voltage

WIRE CONNECTOR ON REAR OF M.I.R.C.

240V/200-40-1

Page A 60A Time Relay
 Part B 60A Control
 Air Tech Class B

0404132

▲ If there is an RT and RT Control, see 0404131C
 Jumper Lead Together and Connect from C to either one.
 ▲ For 200V operation, connect this
 wire to 200V transformer tap.

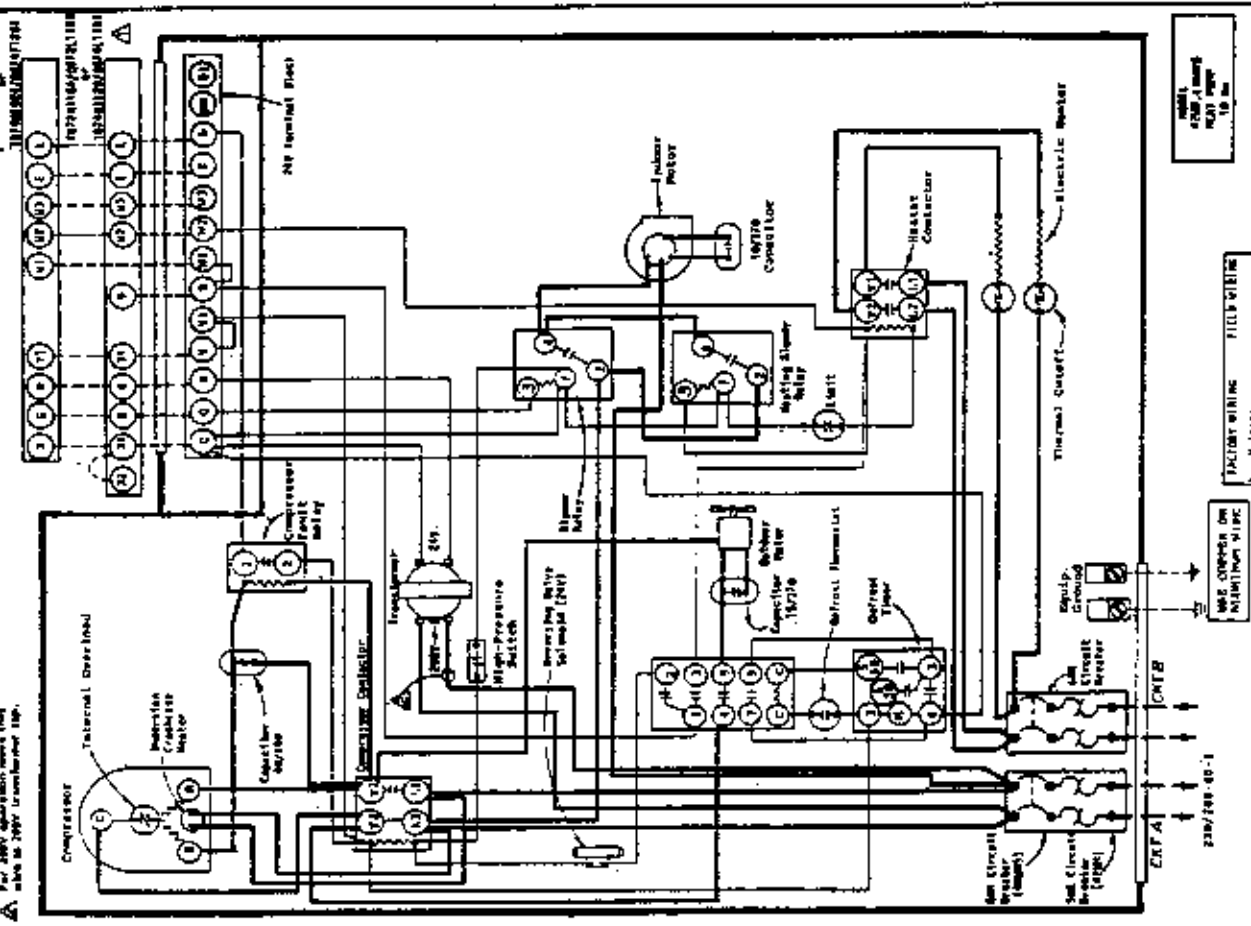

FACTORY WIRING
 Low Voltage
 High Voltage

WIRE CONNECTOR ON REAR OF M.I.R.C.

240V/200-40-1

Page A 60A Time Relay
 Part B 60A Control
 Air Tech Class B

0404131C

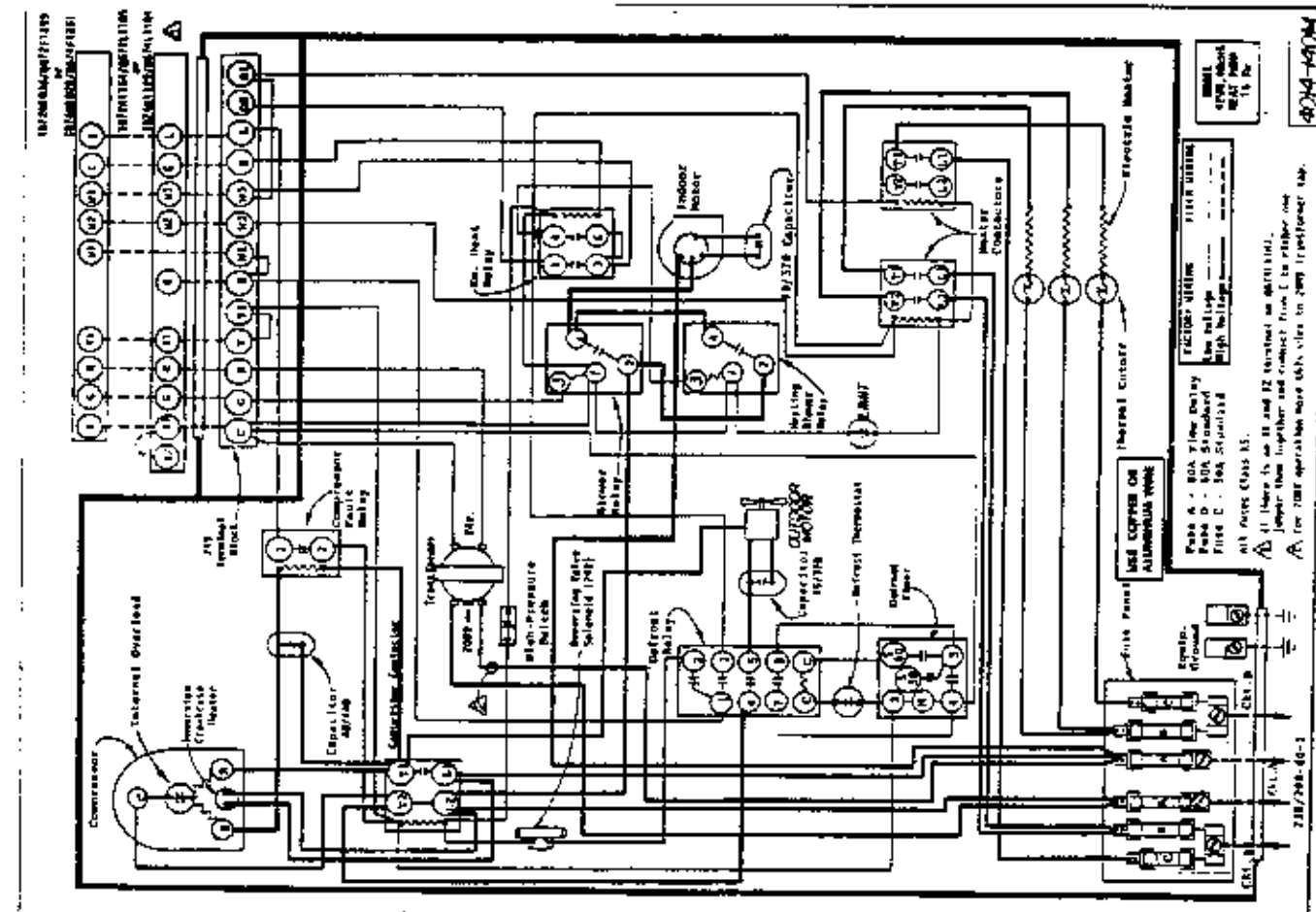
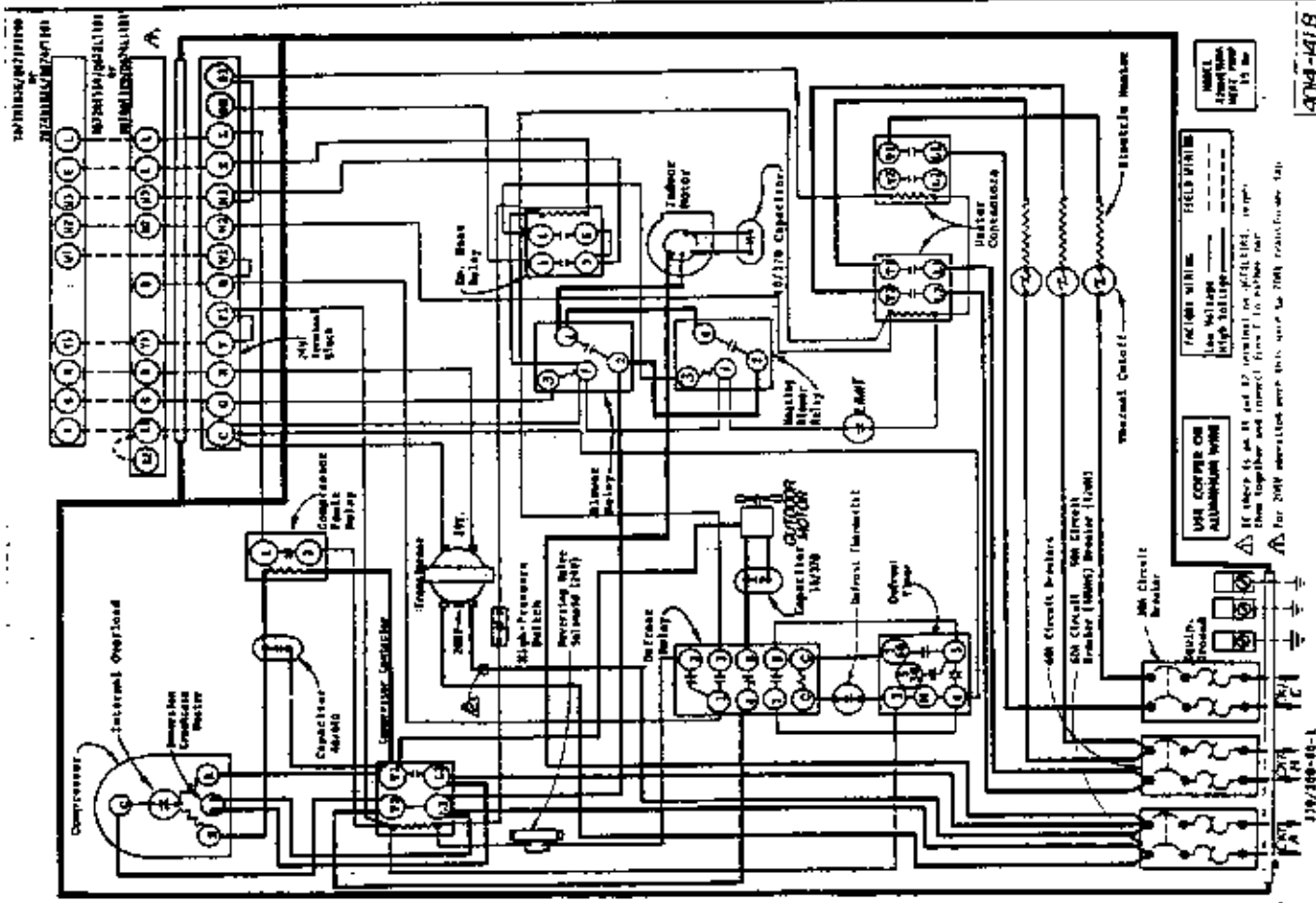

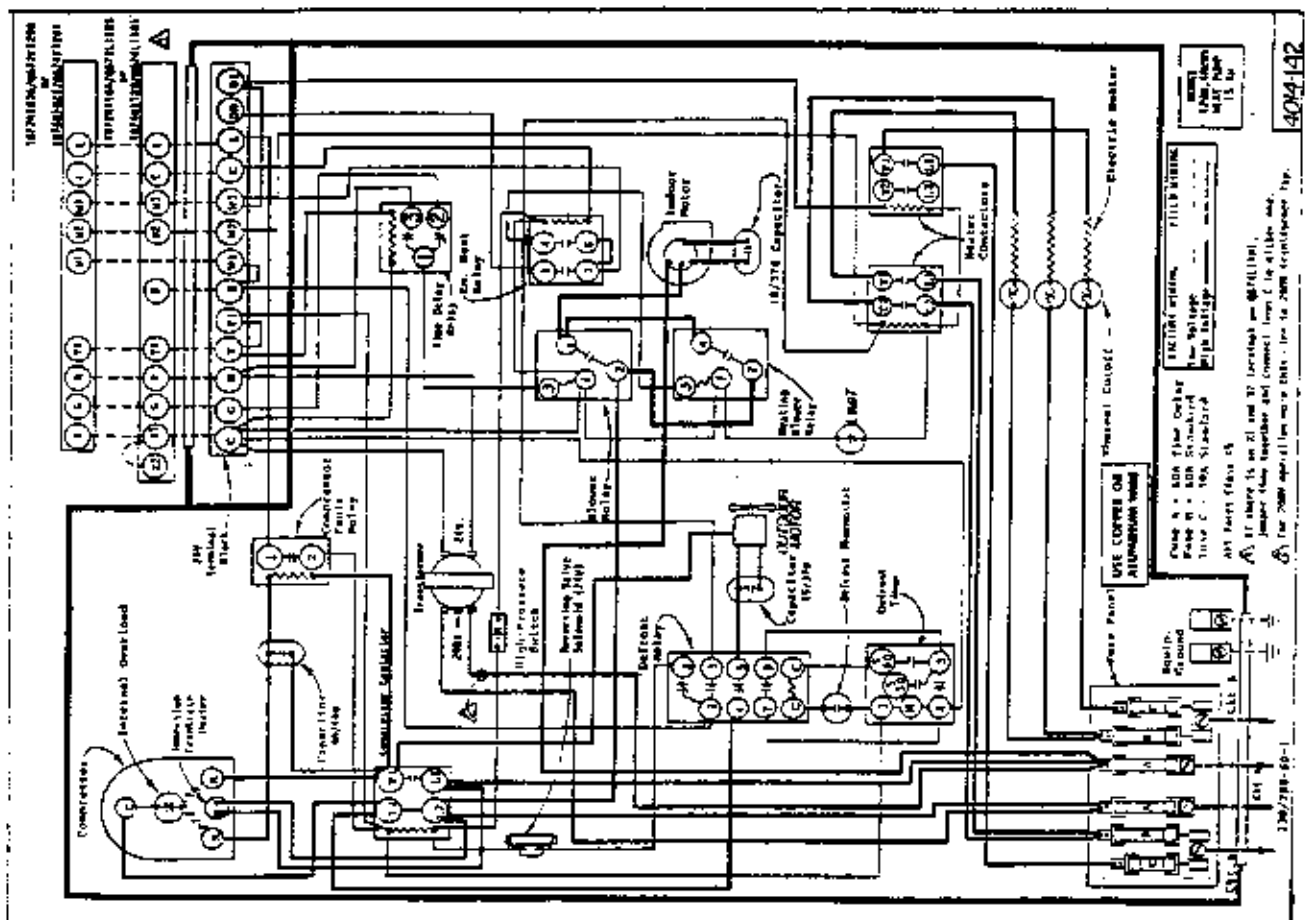
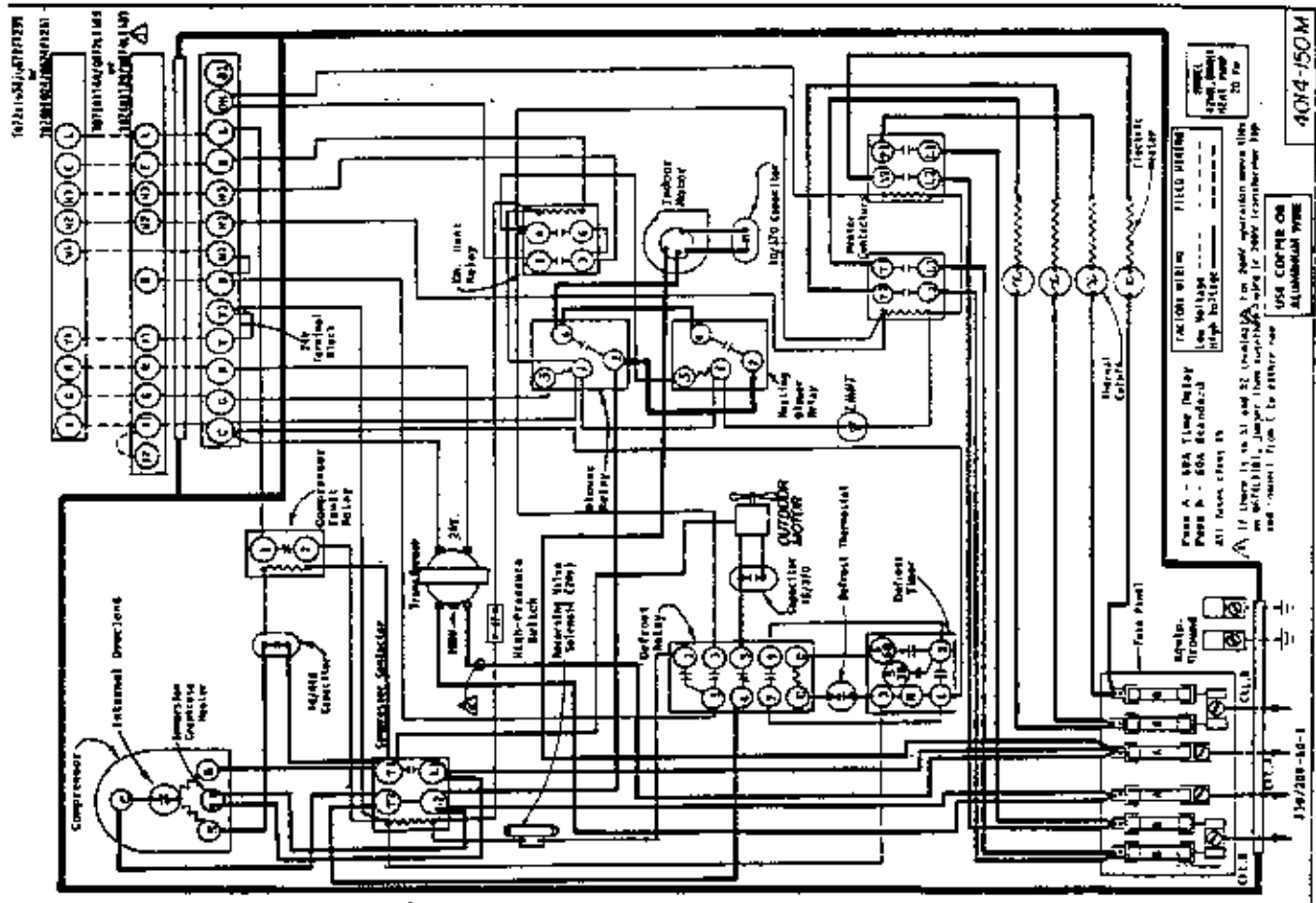

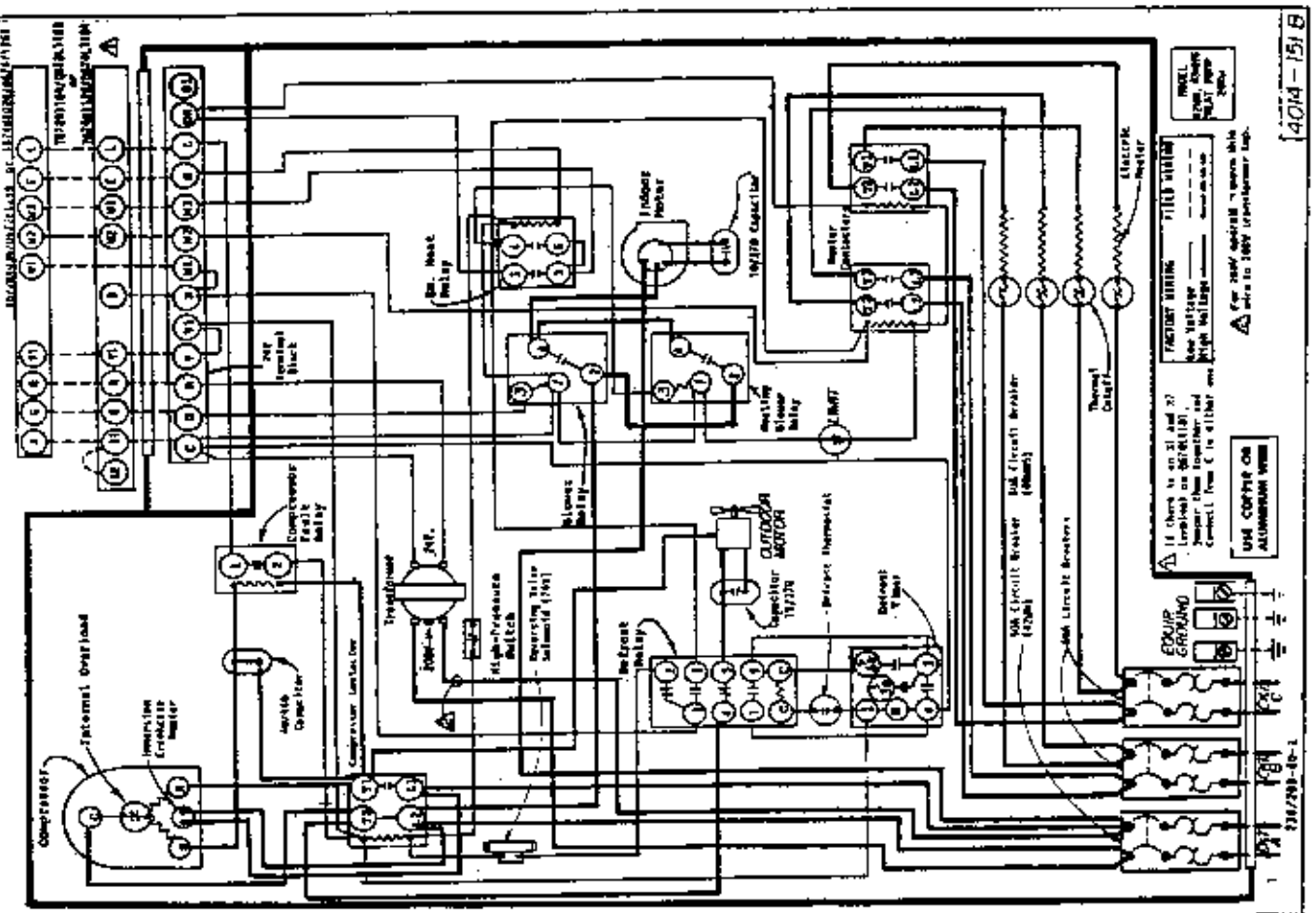
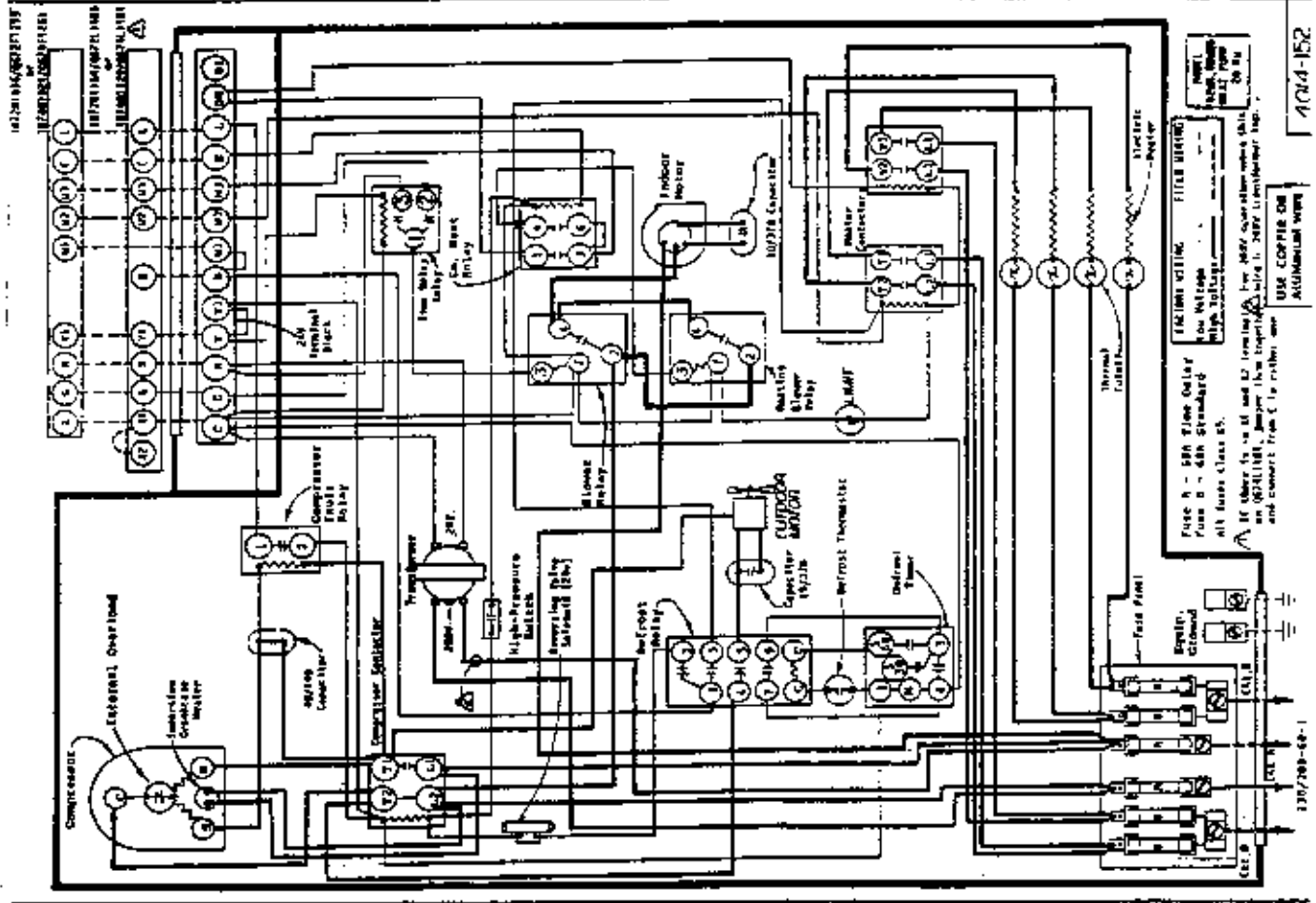

FACTORY WIRING
 See Voltage
 High Voltage
 ALL Wires Class B5

USE COPPER OR ALUMINUM WIRES

IF there is an 21 and 27 terminal on (20) (151B), jumper from terminal 27 to 28. For 28V operation, omit 28A and connect from C to 41A, see 130/790-62-1

FACTORY WIRING
 See Voltage
 High Voltage
 ALL Wires Class B5

USE COPPER OR ALUMINUM WIRES

IF there is an 21 and 27 terminal on (20) (151B), jumper from terminal 27 to 28. For 28V operation, omit 28A and connect from C to 41A, see 130/790-62-1

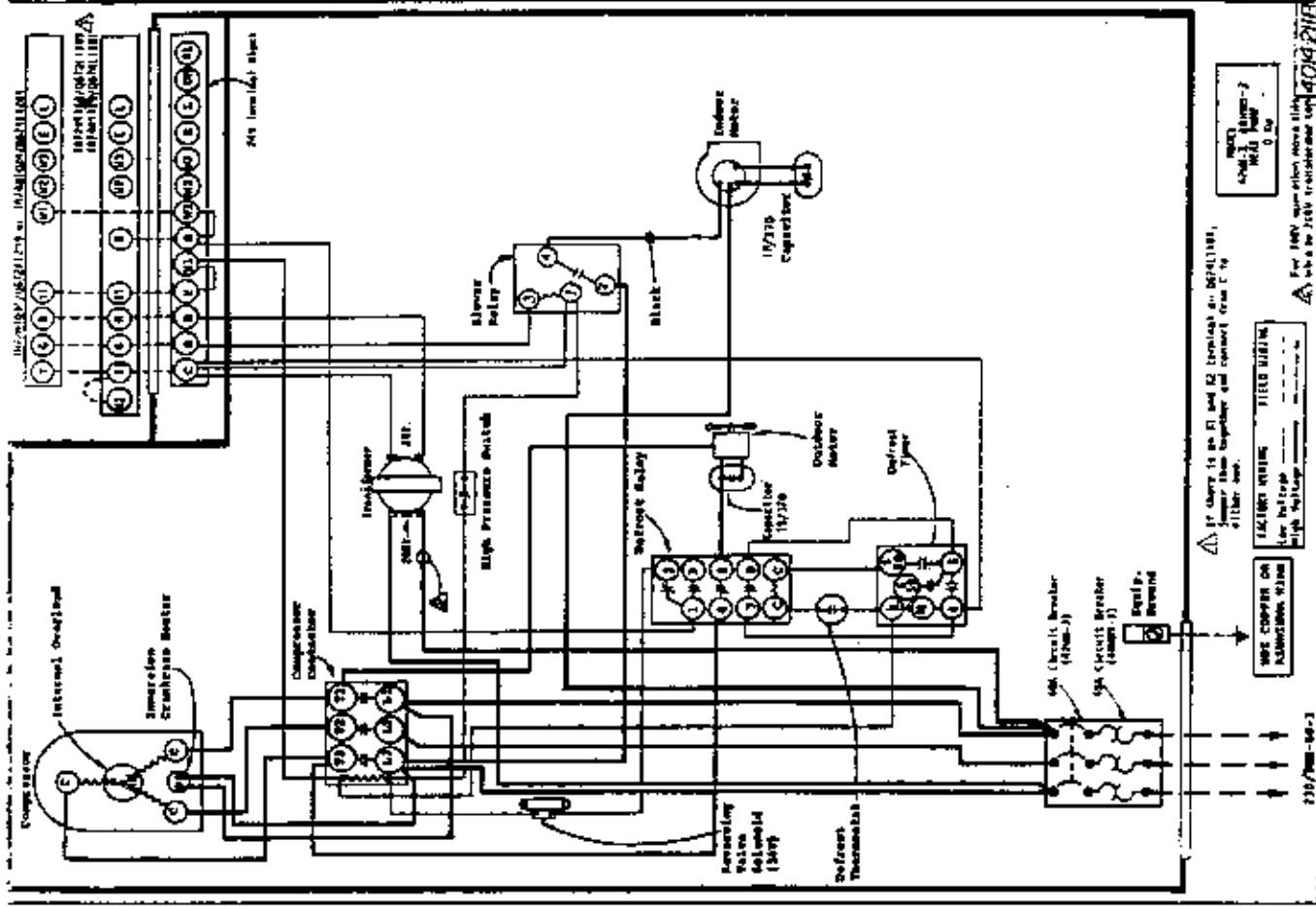
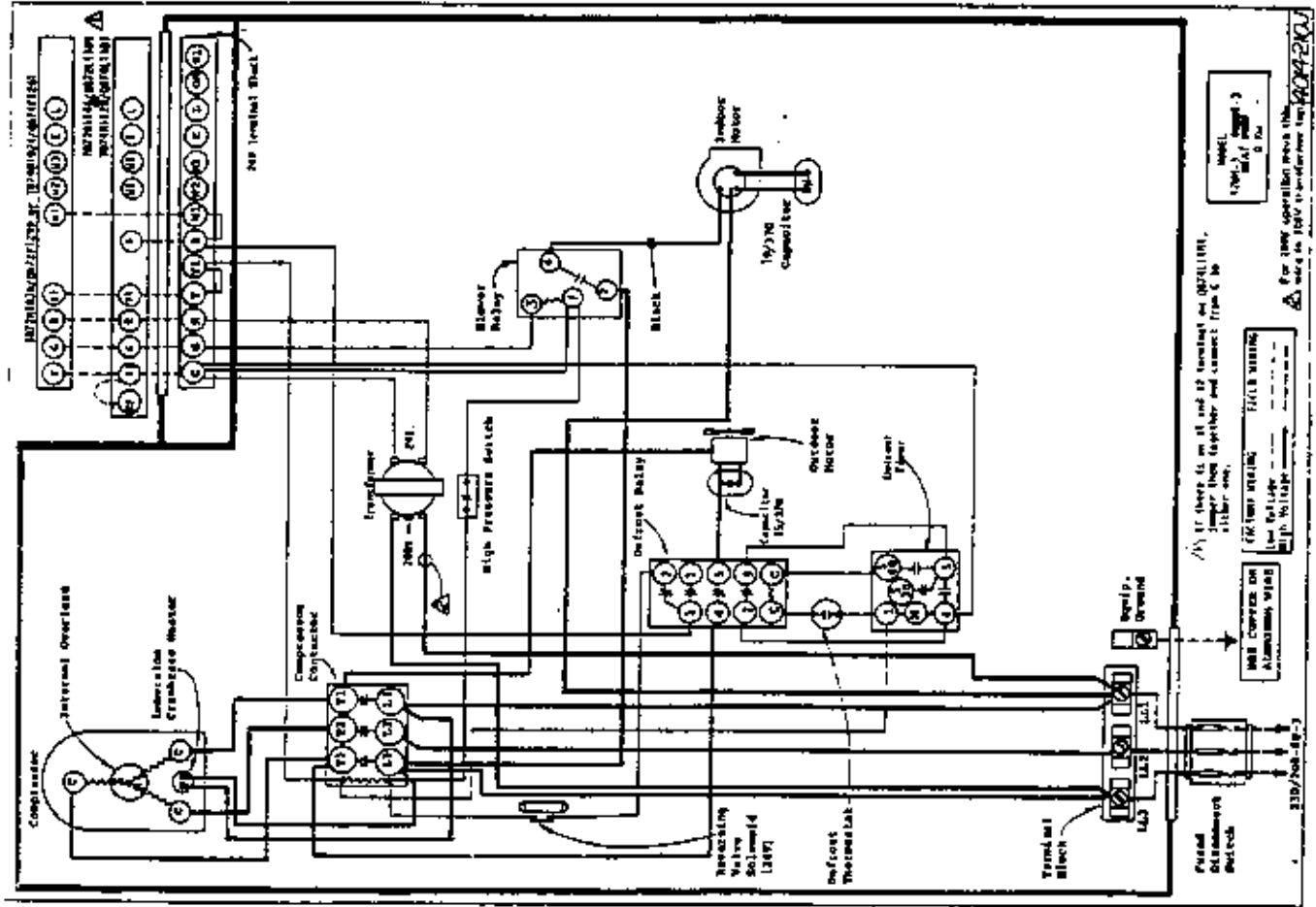

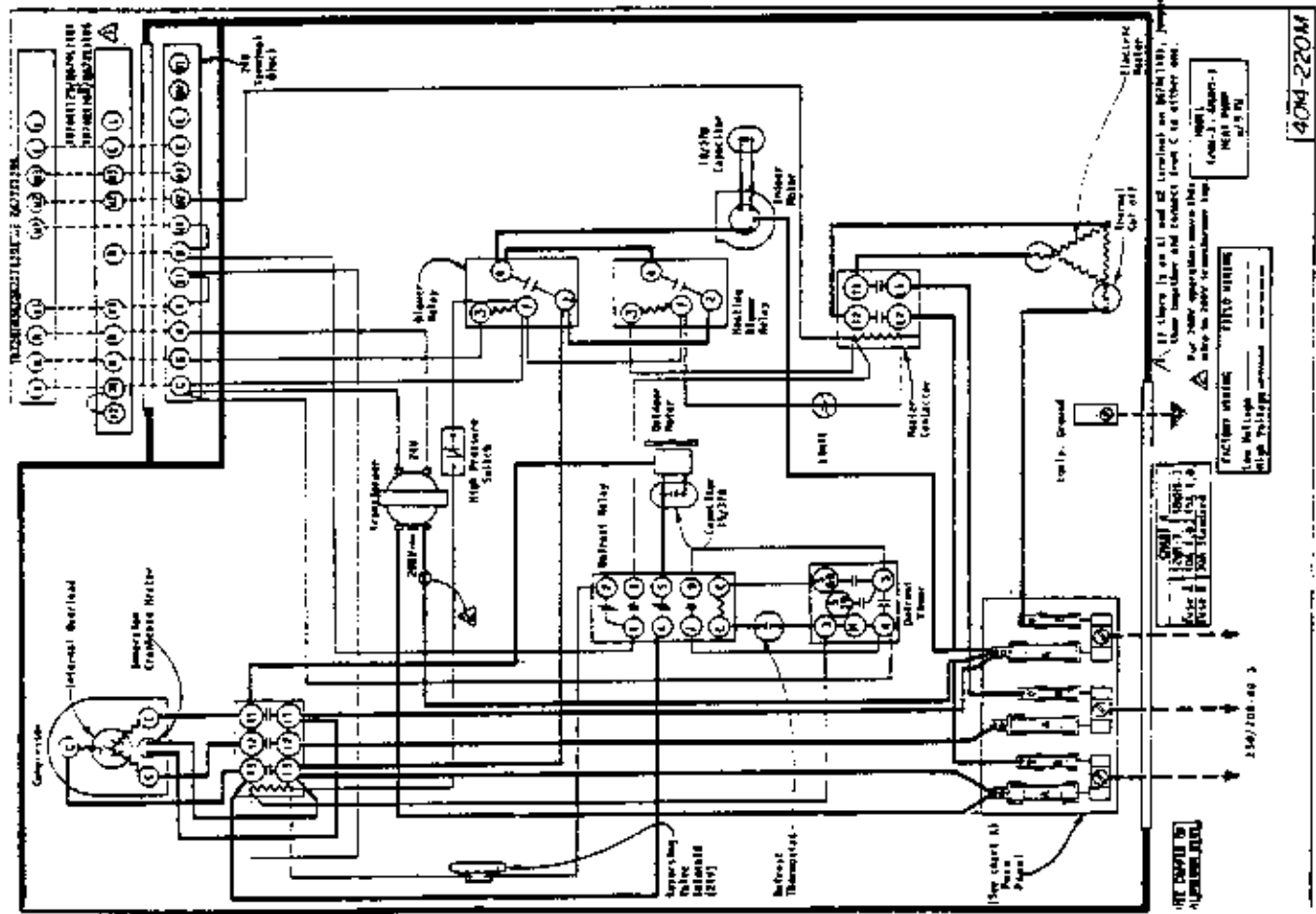
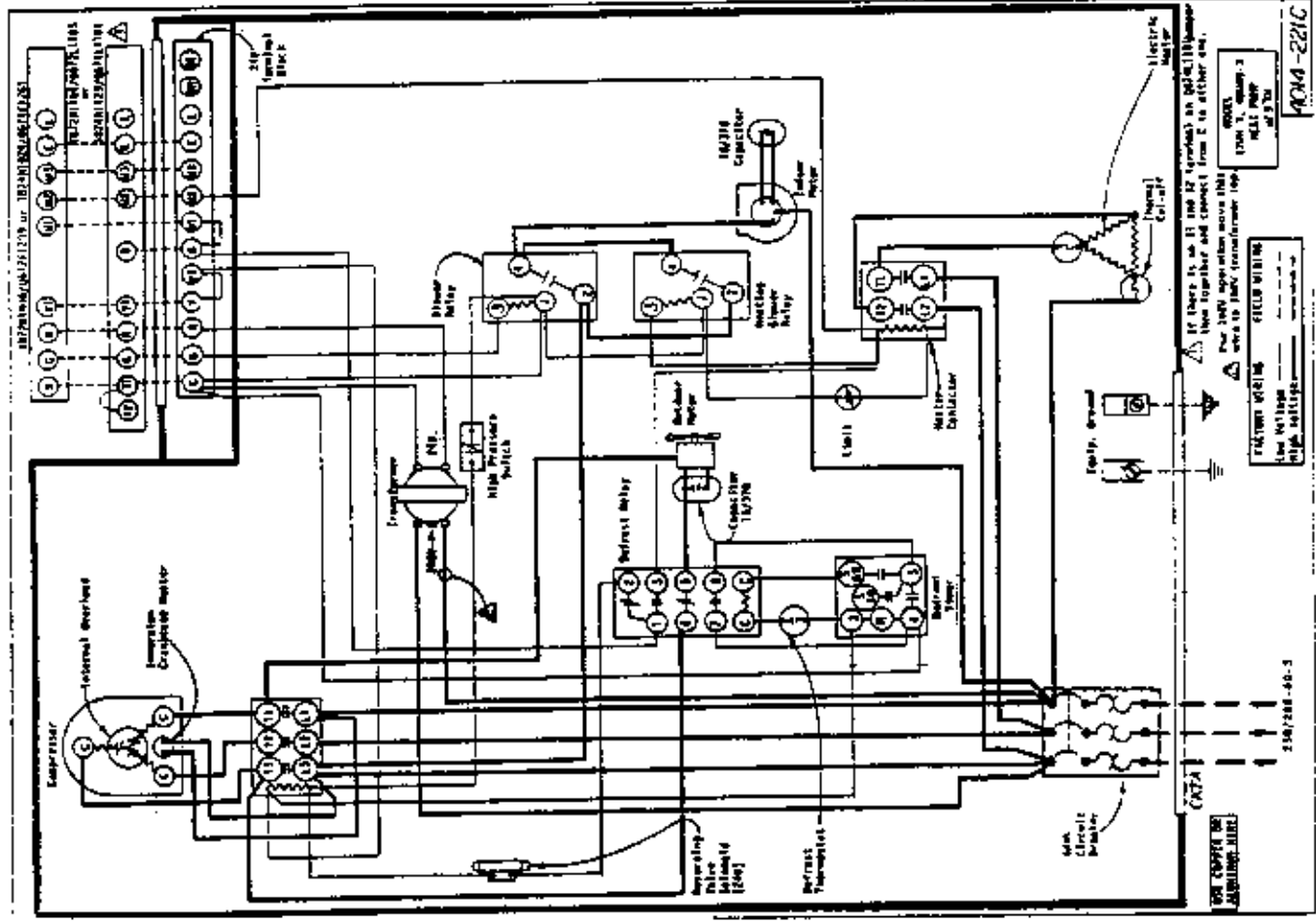

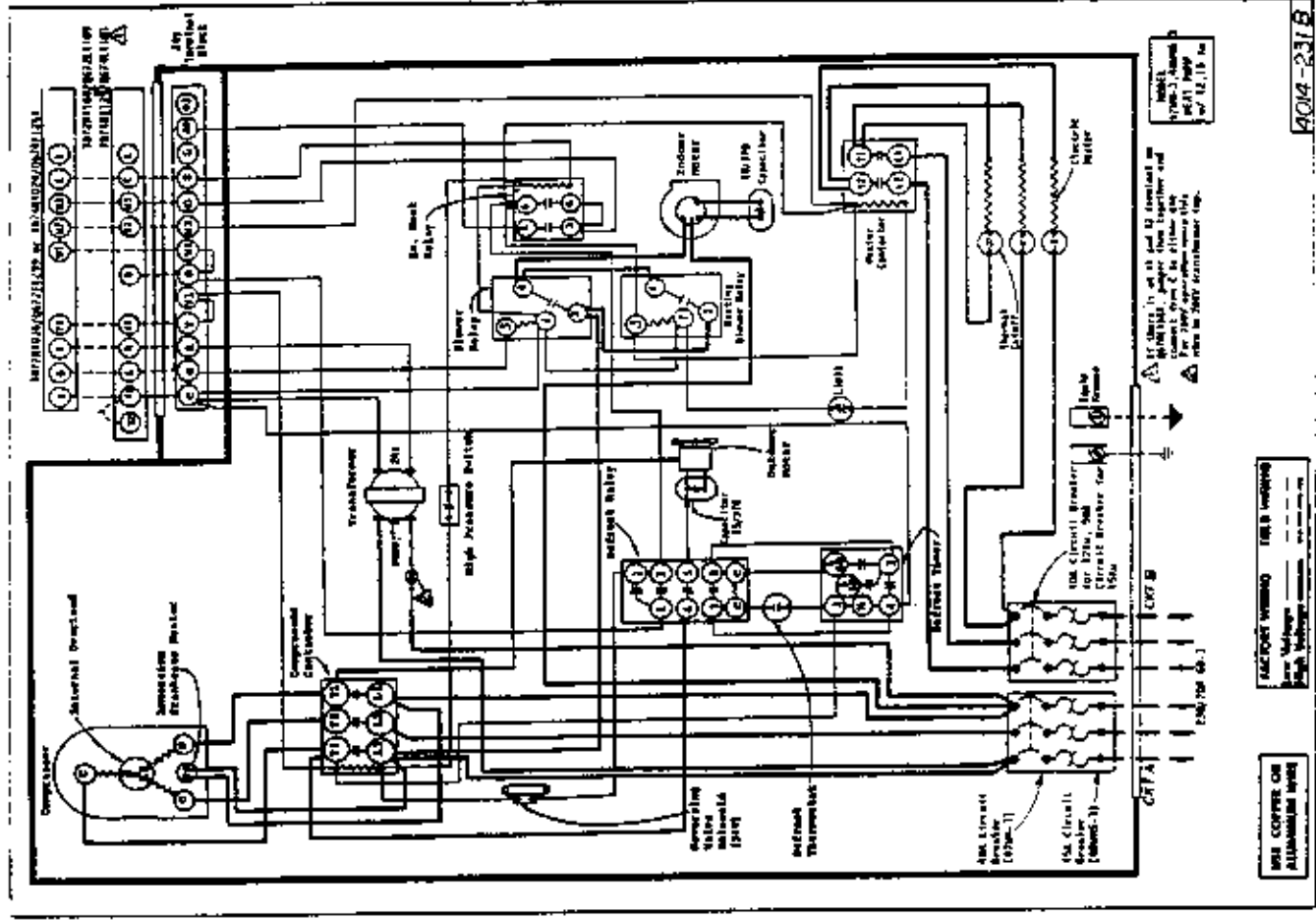
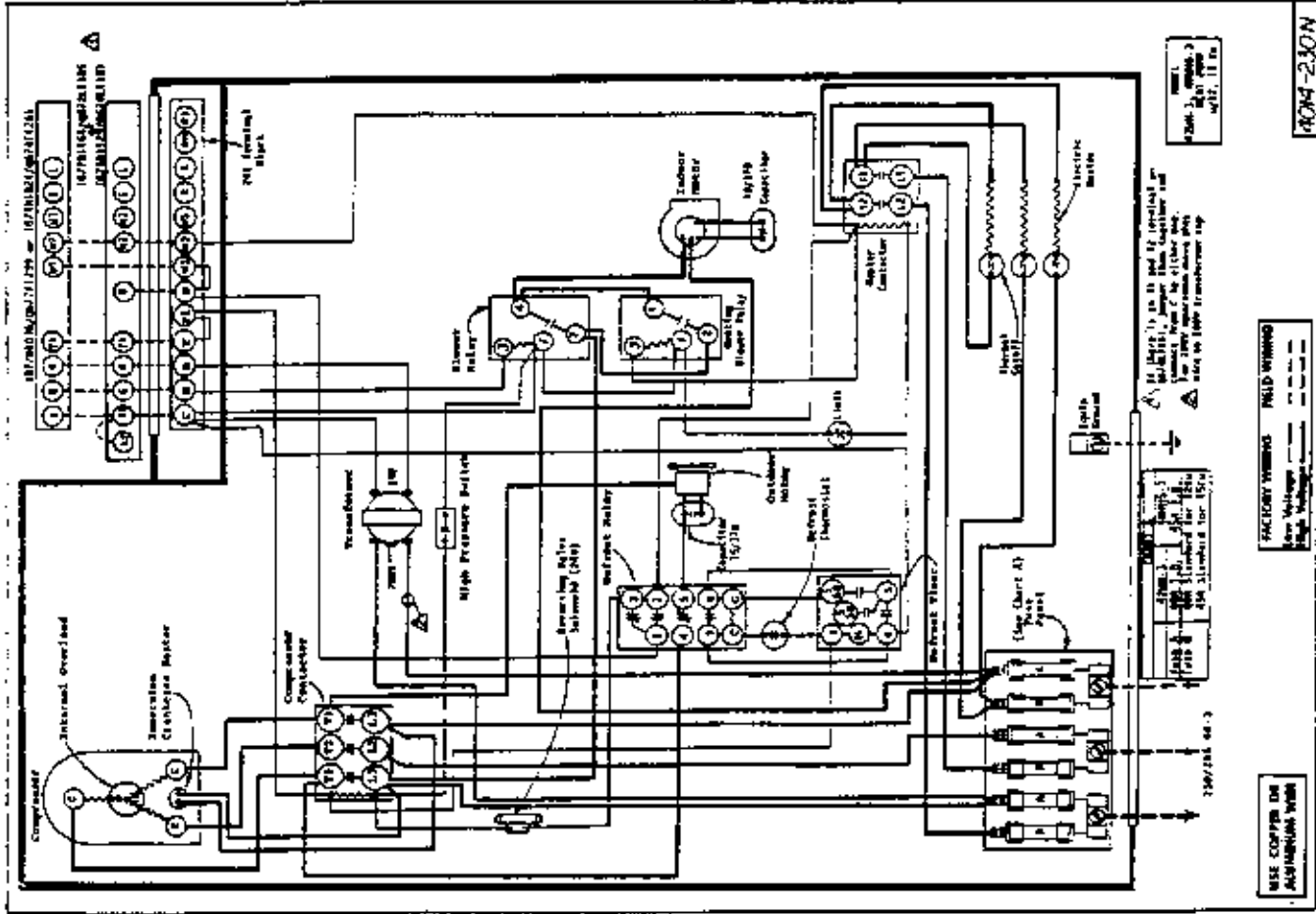

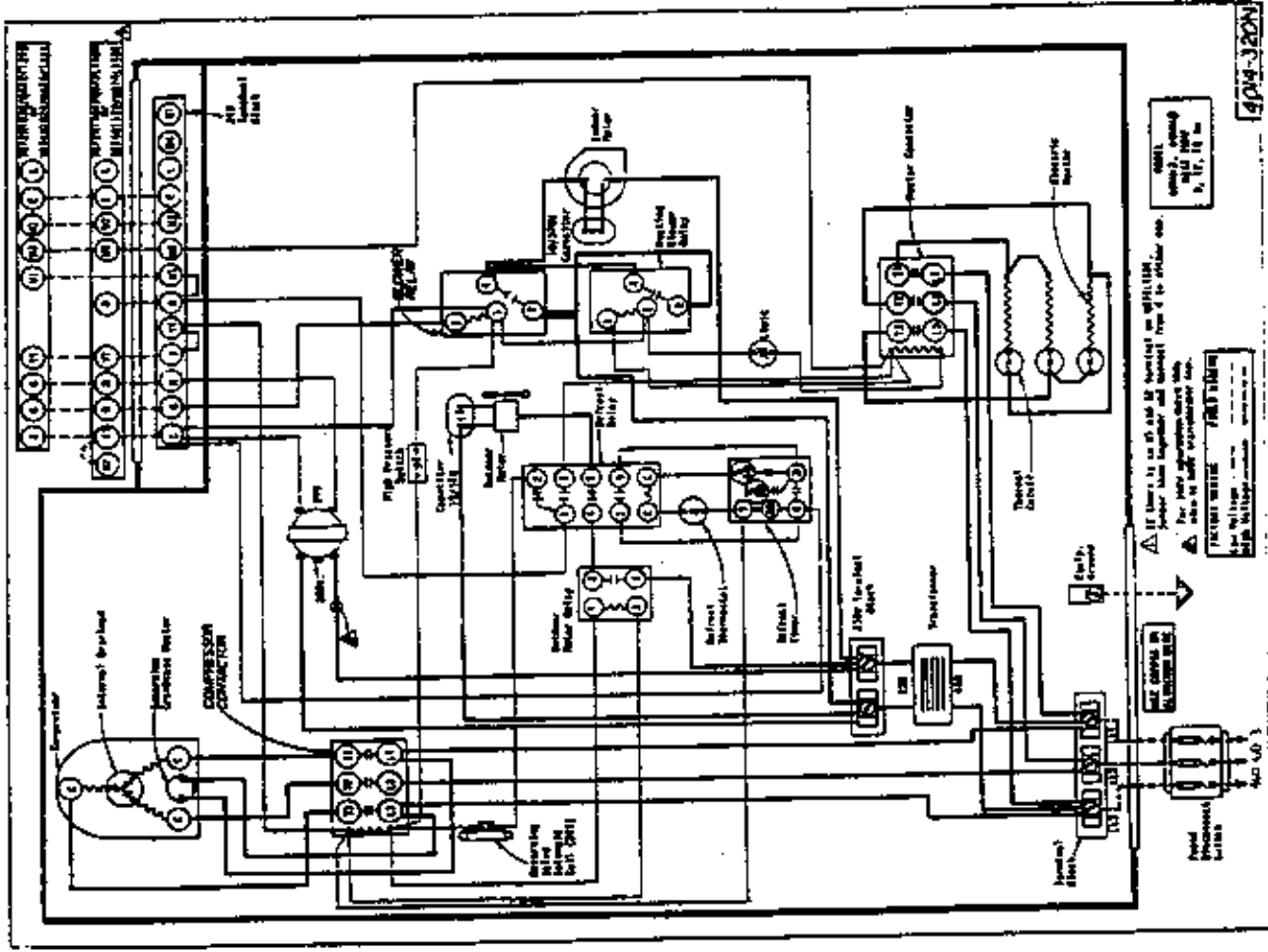
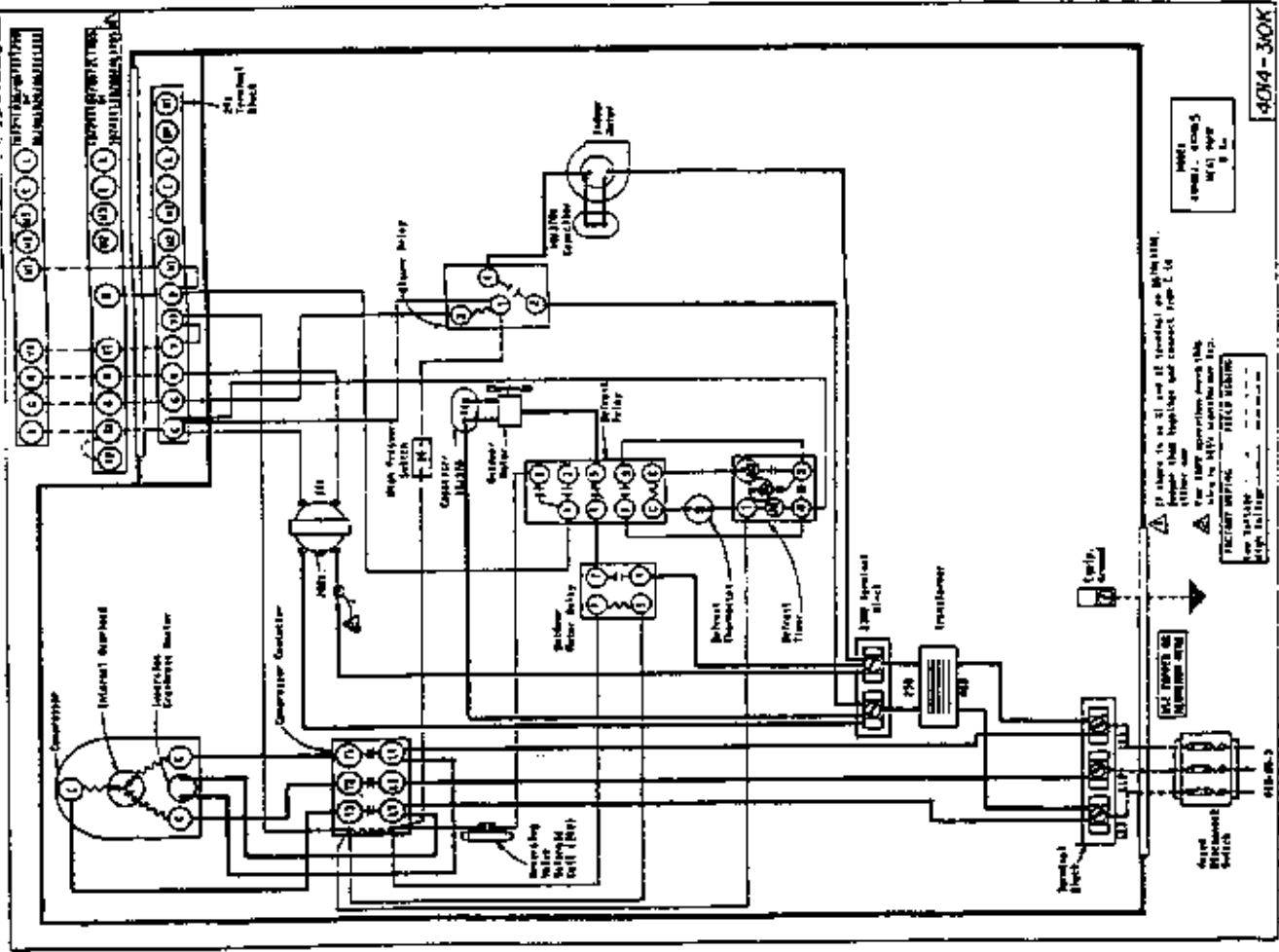

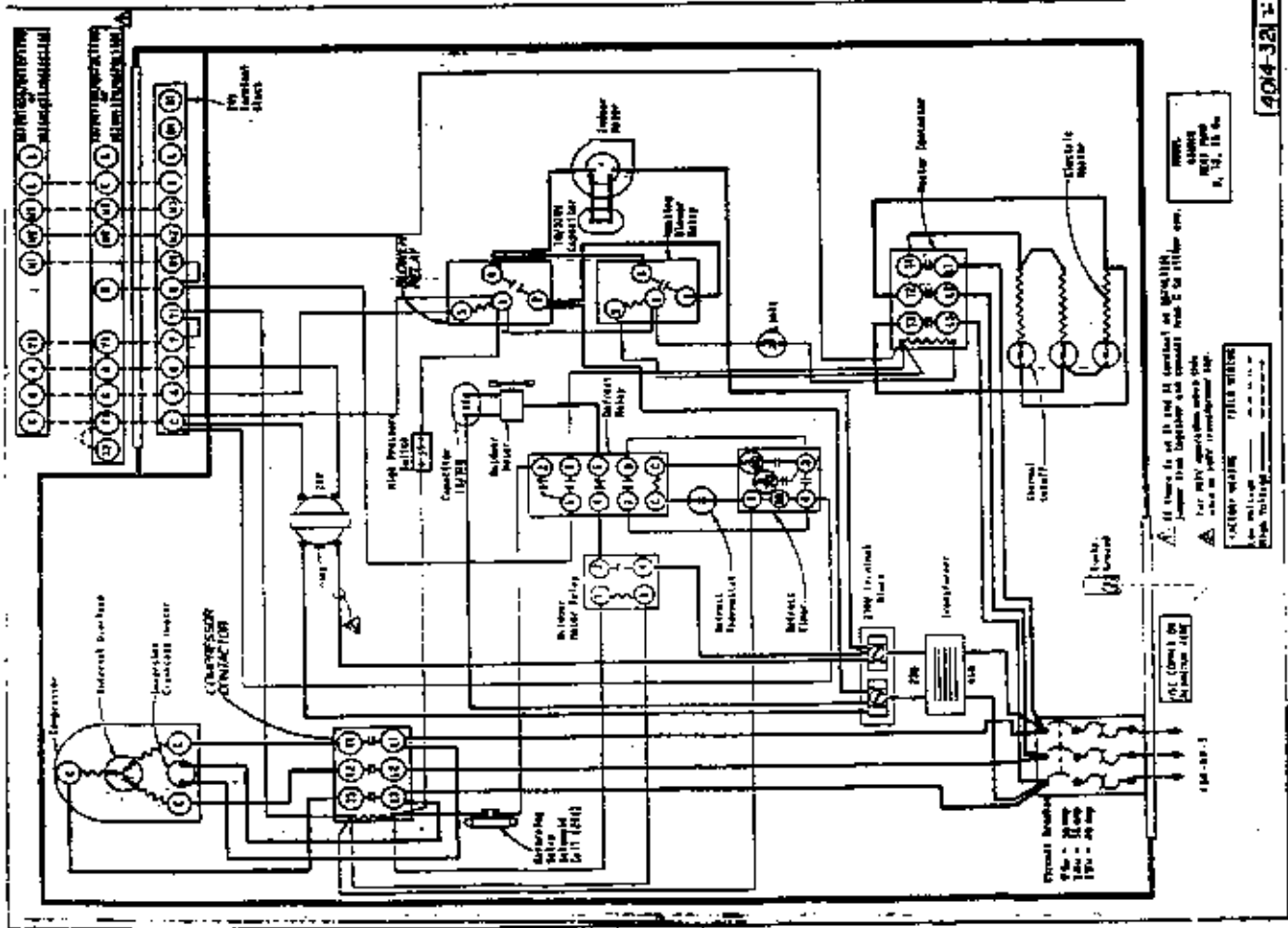

404-32-1

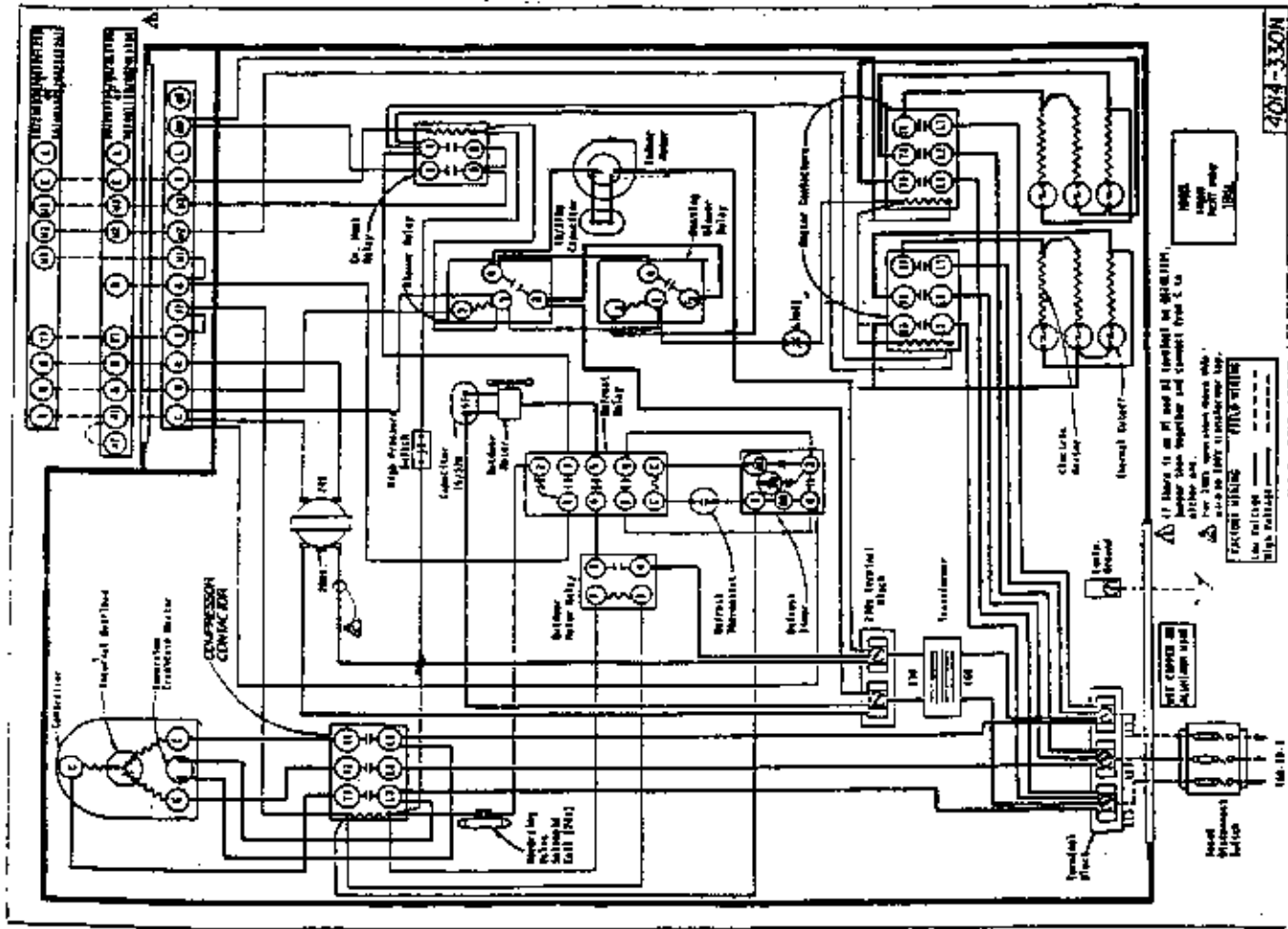

404-33-1

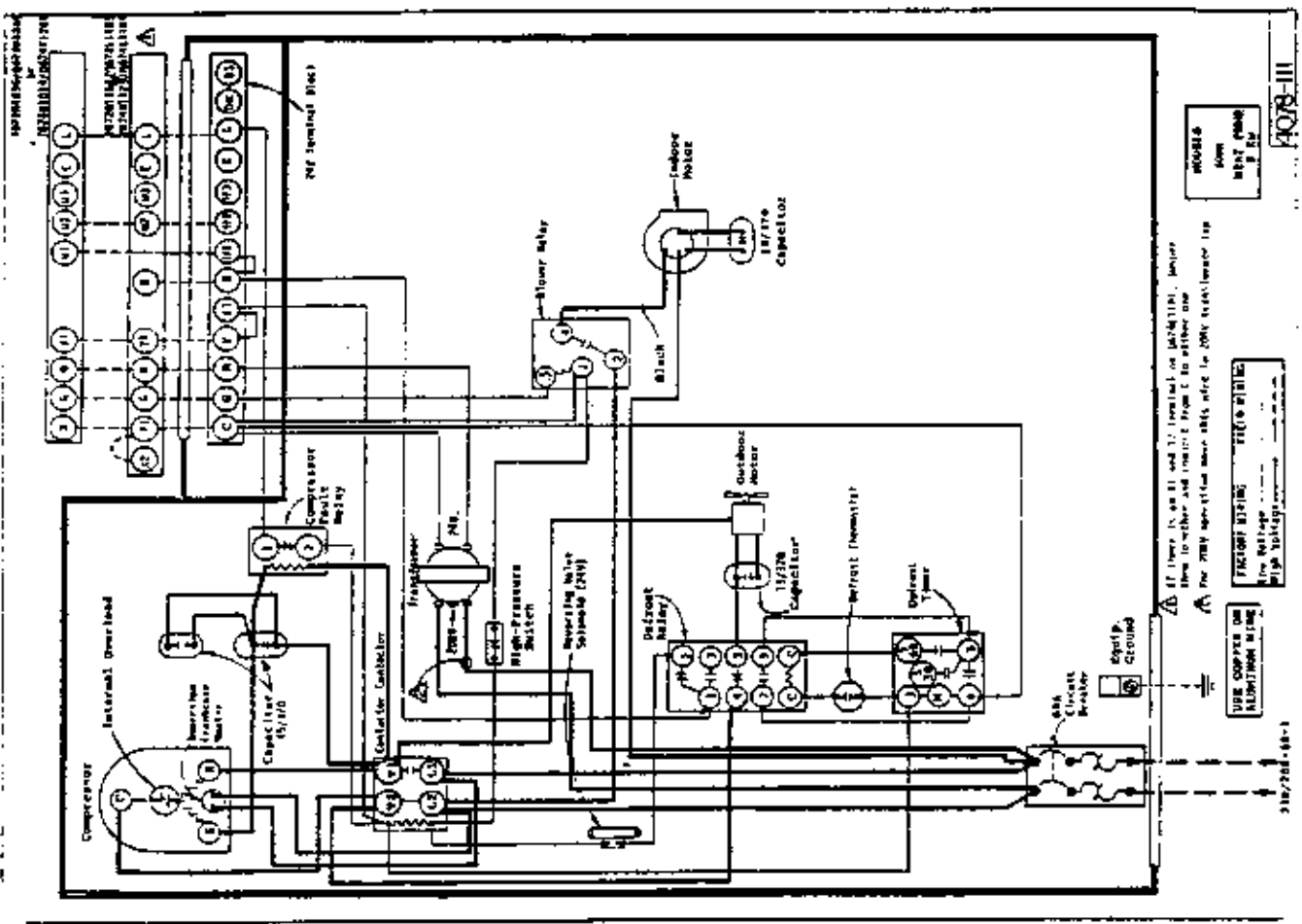
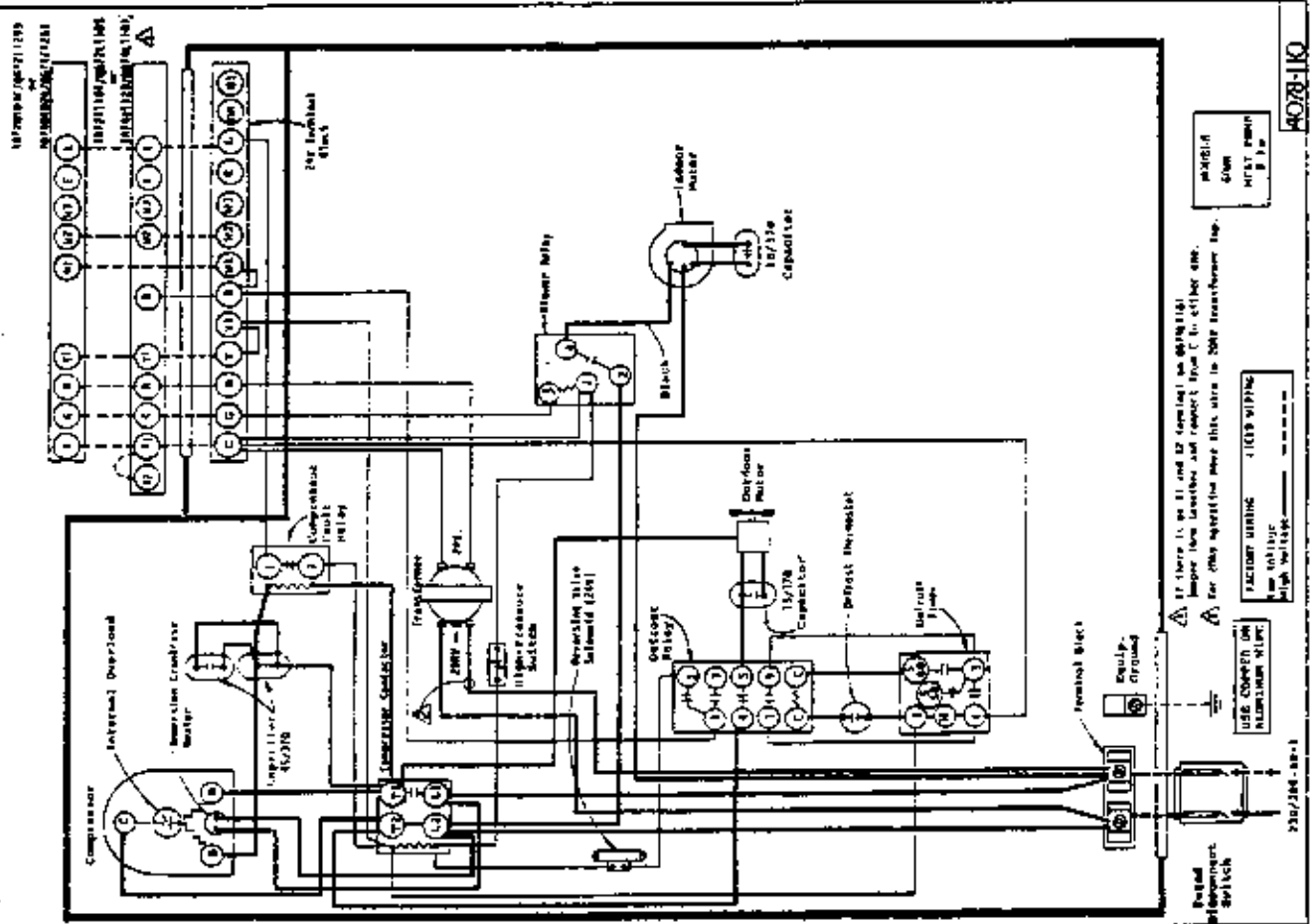

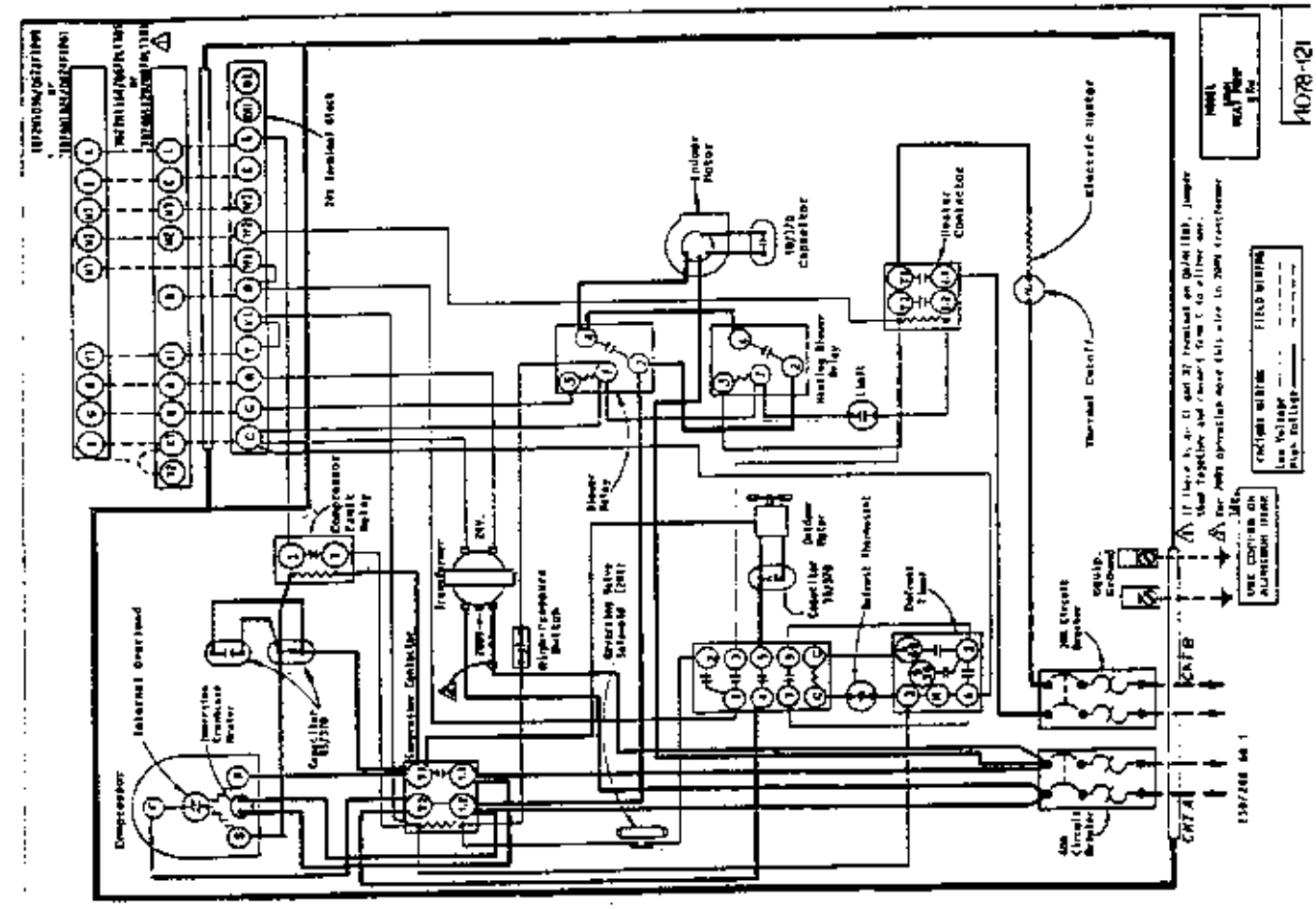
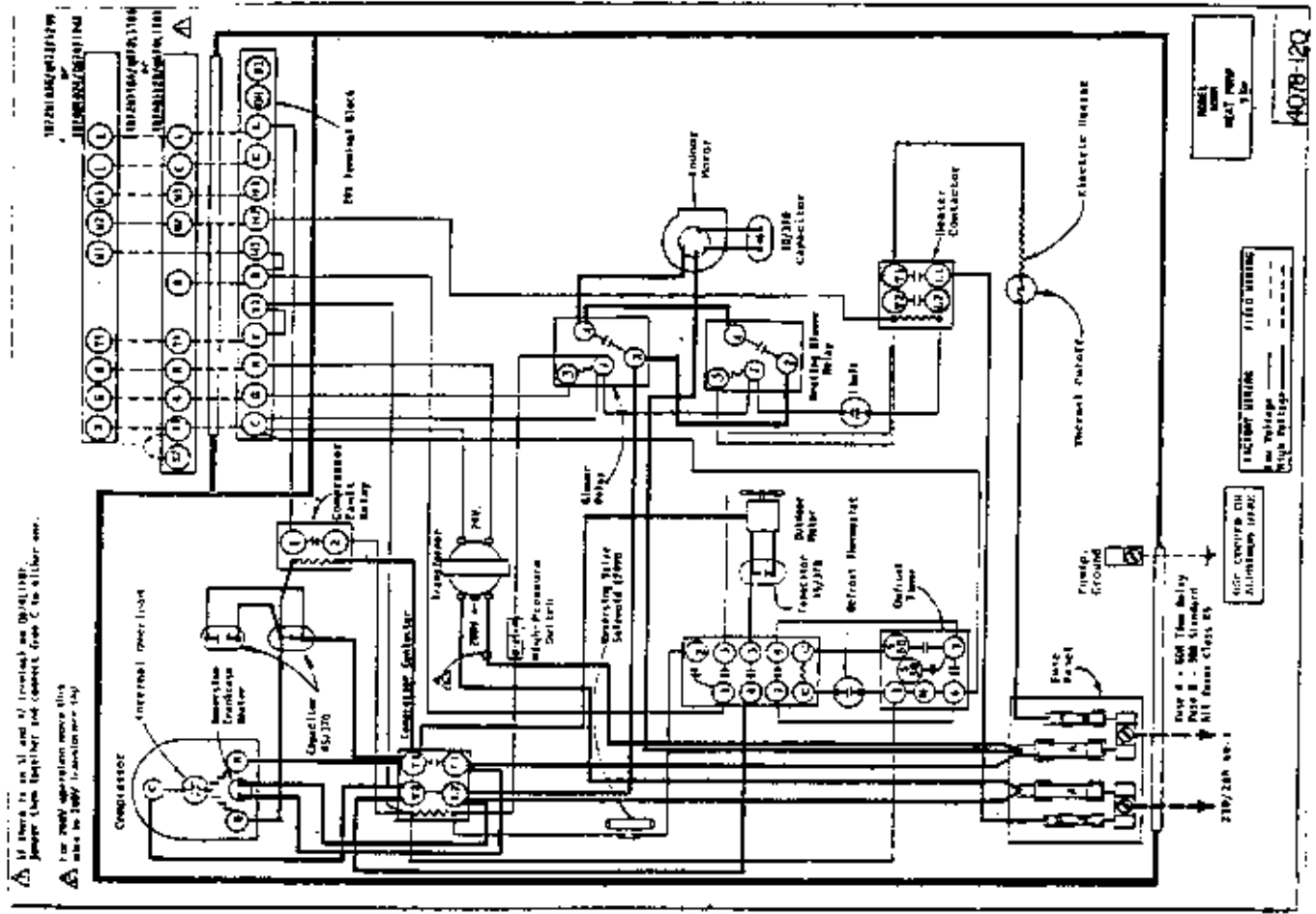

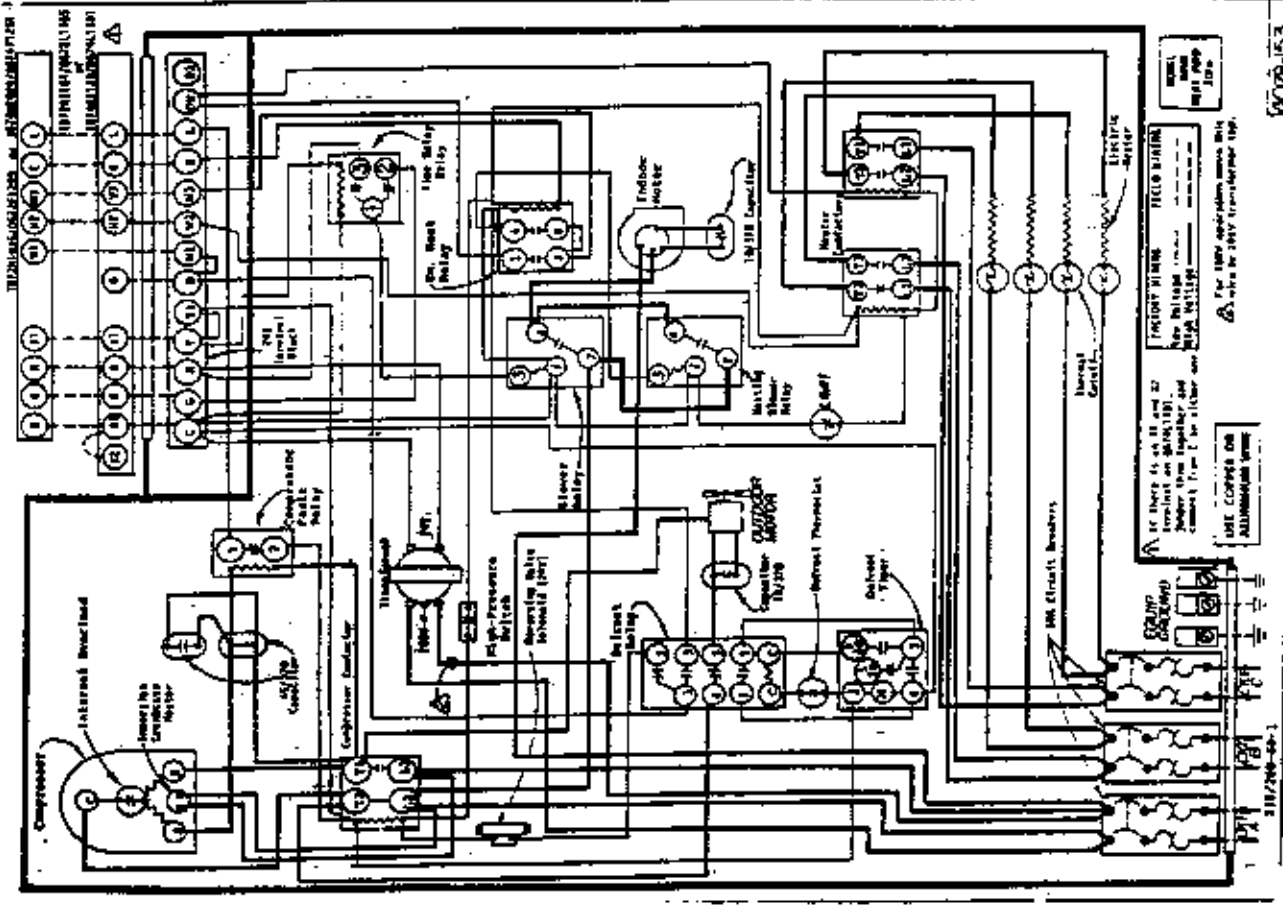
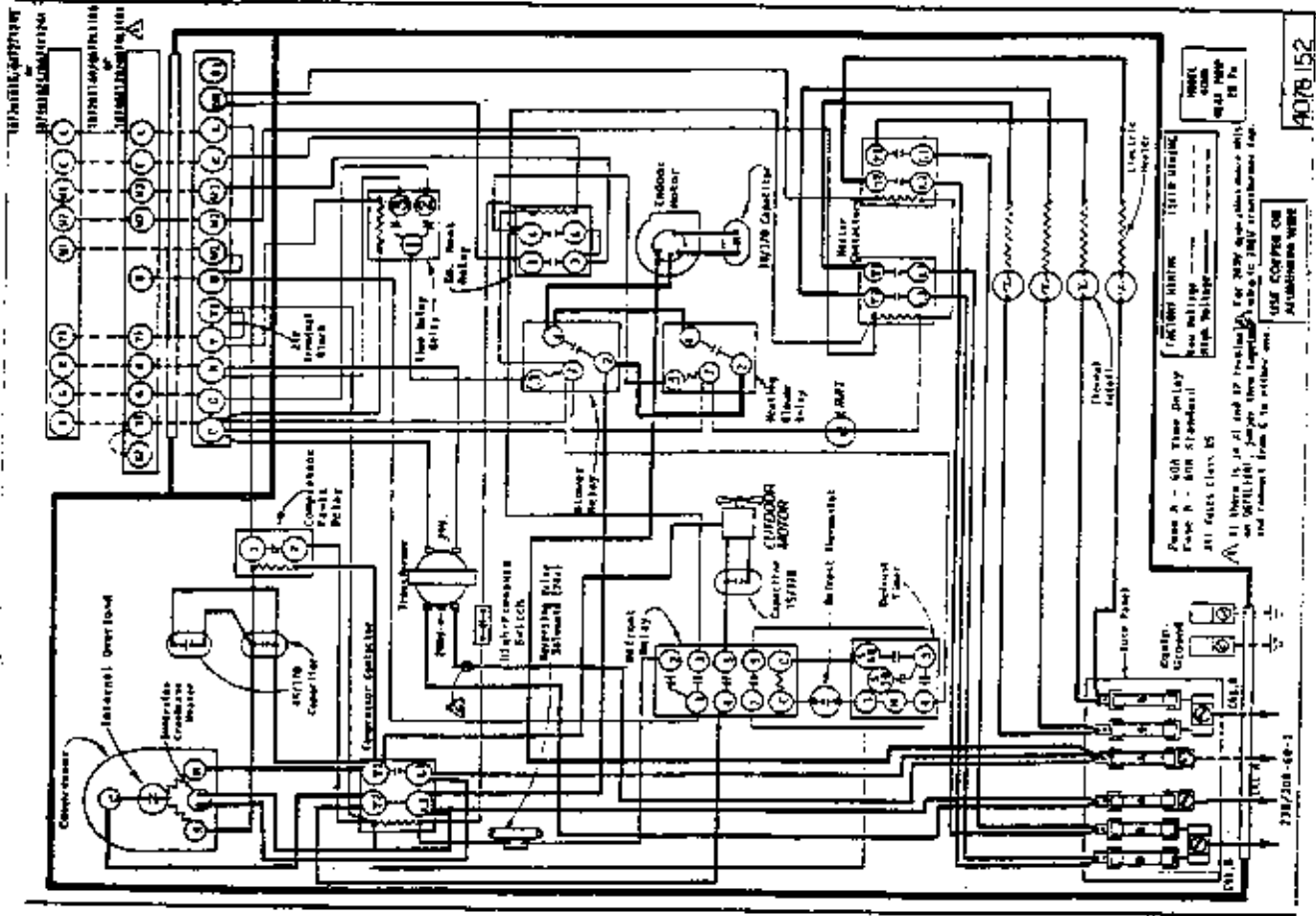

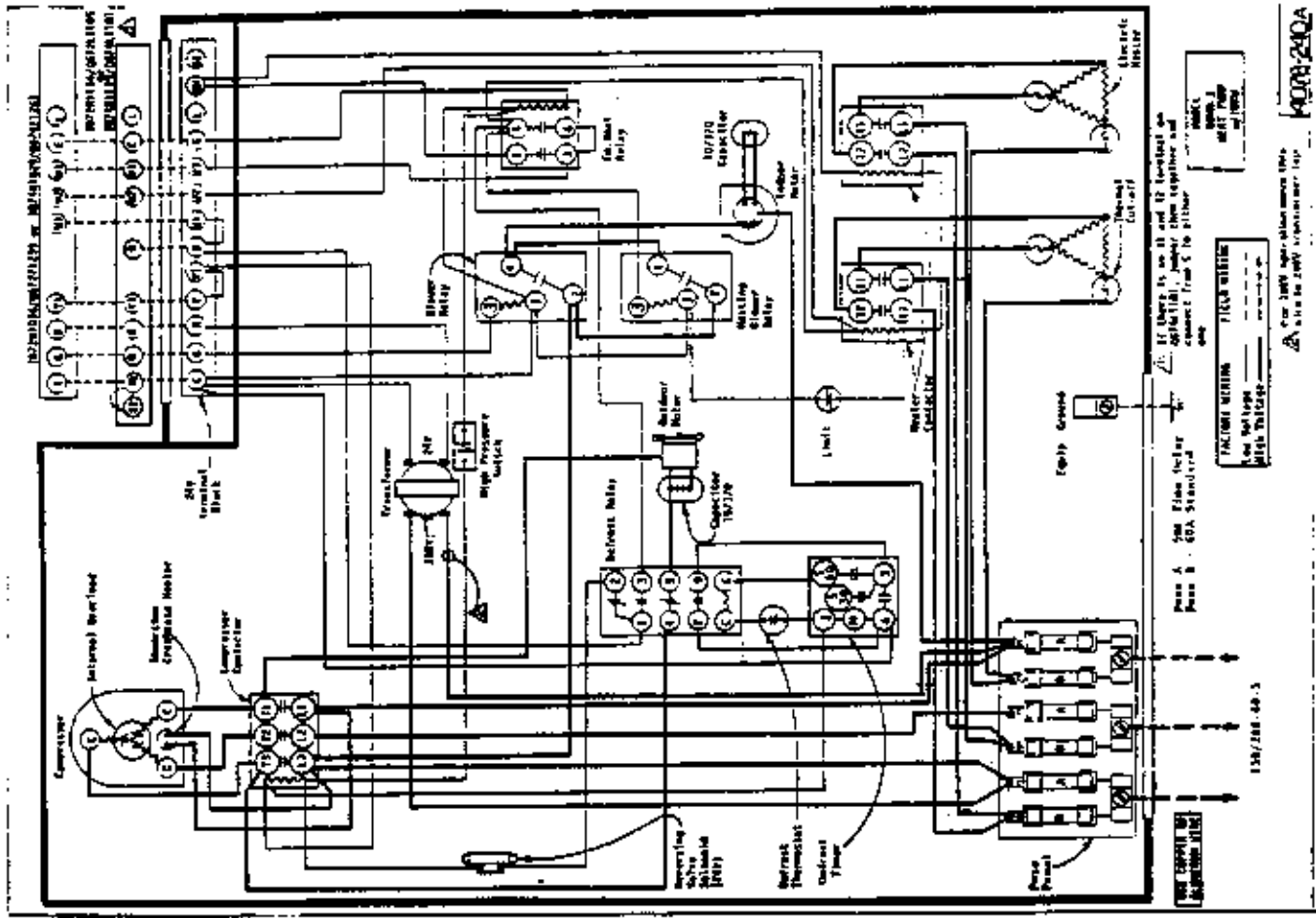

4078-210A

FOR 240V OPERATION USE THE 240V TERMINAL TAB

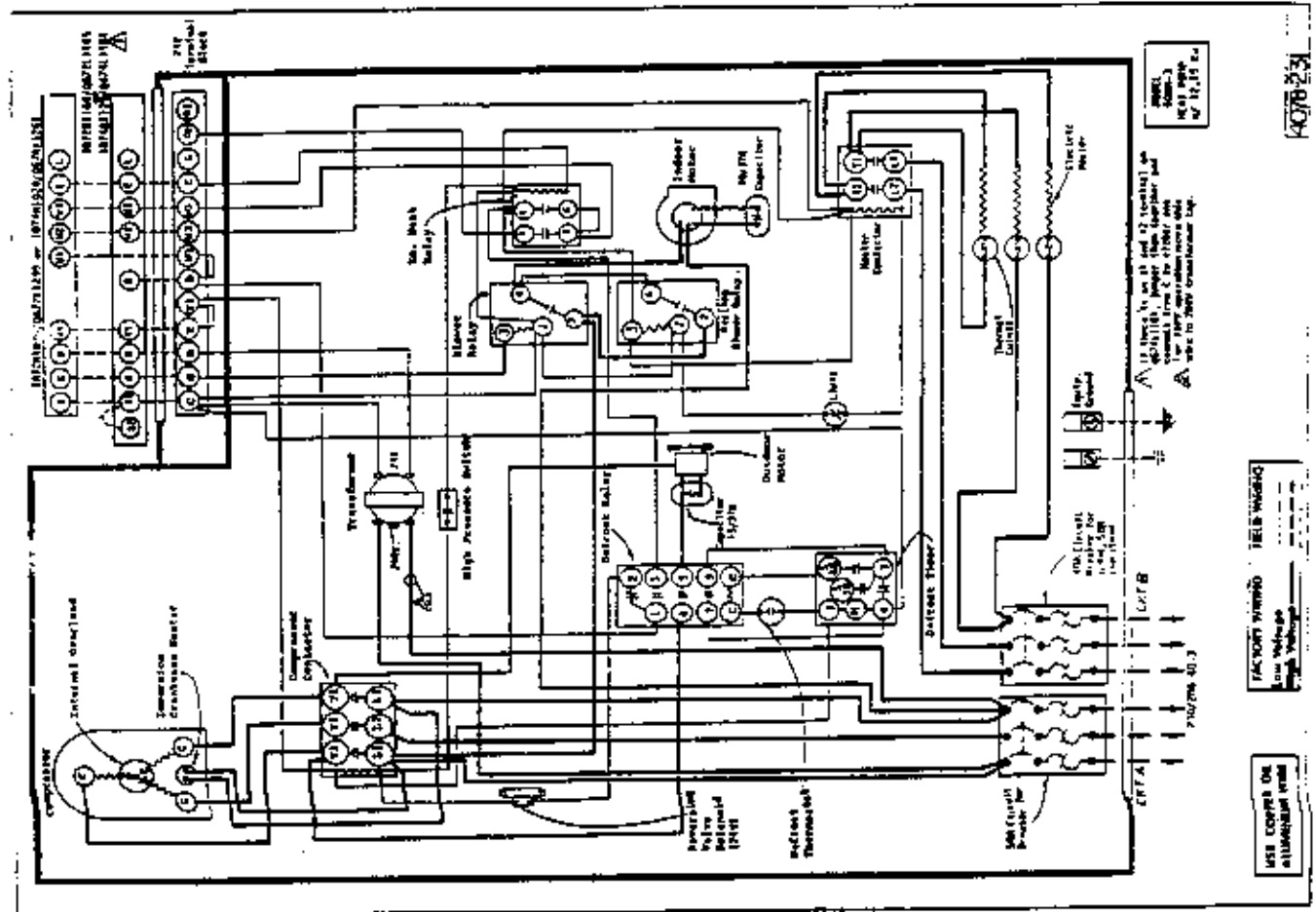

4078-211

FOR 240V OPERATION USE THE 240V TERMINAL TAB

