

INSTALLATION INSTRUCTIONS

MODELS

HWP30

HWPD30*

HWP36

HWPD36*

*Built-in hot water heat exchanger.

HIGH EFFICIENCY

WATER SOURCE

HORIZONTAL PACKAGED HEAT PUMPS

WATER TEMPERATURES: 25 to 105°F

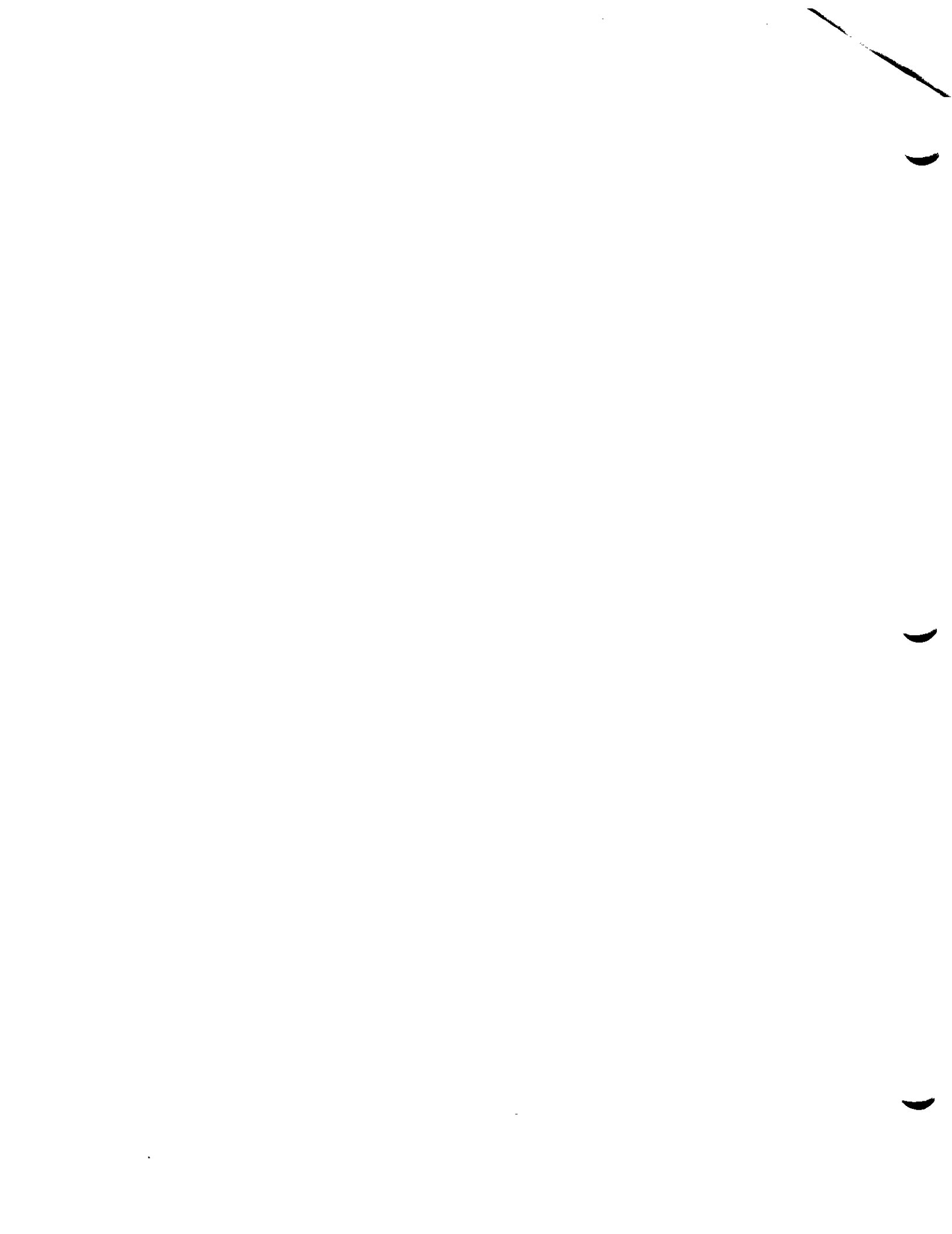

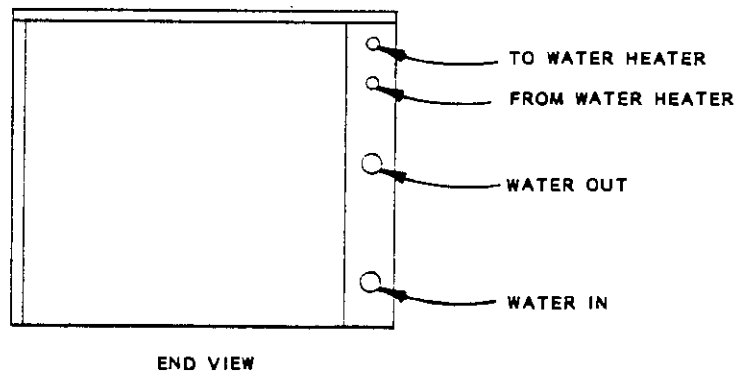
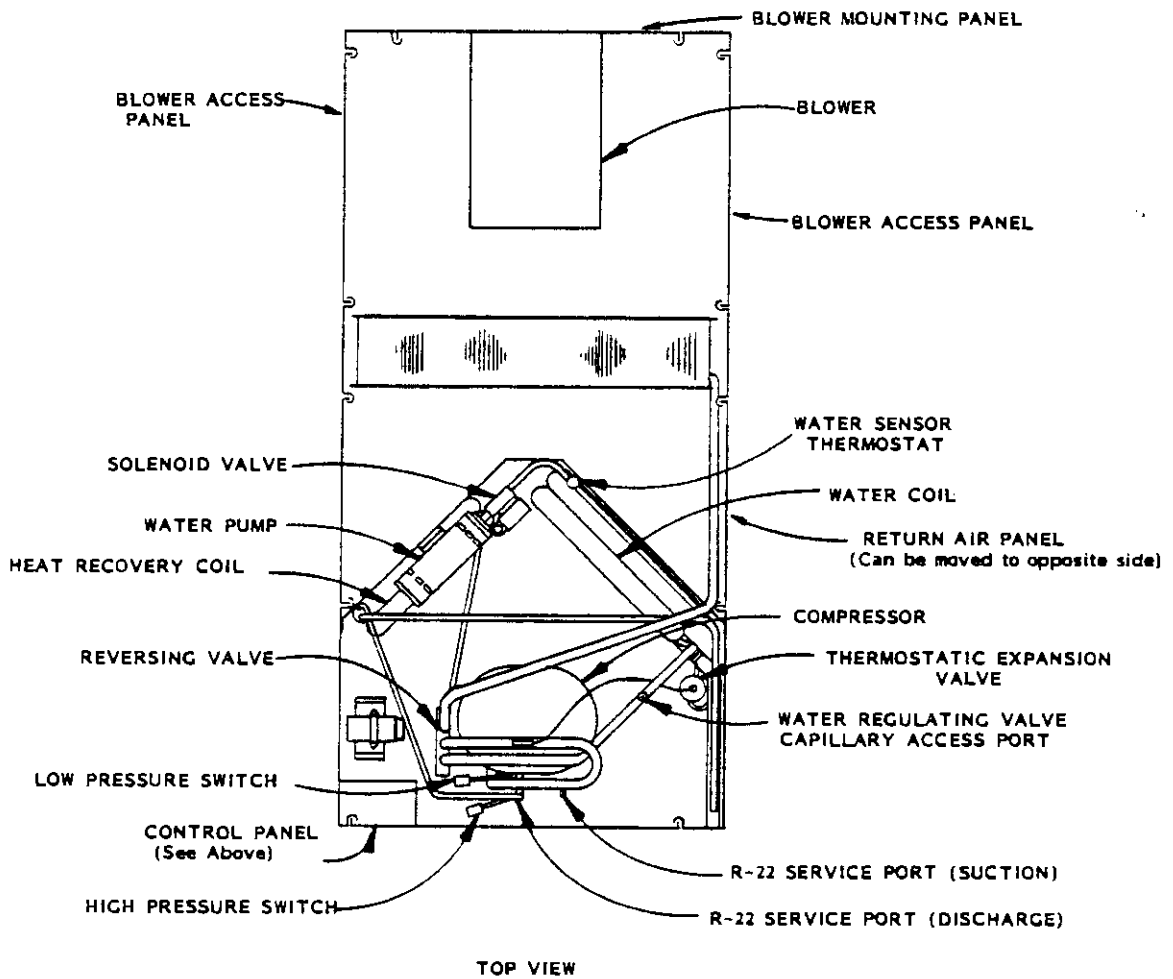
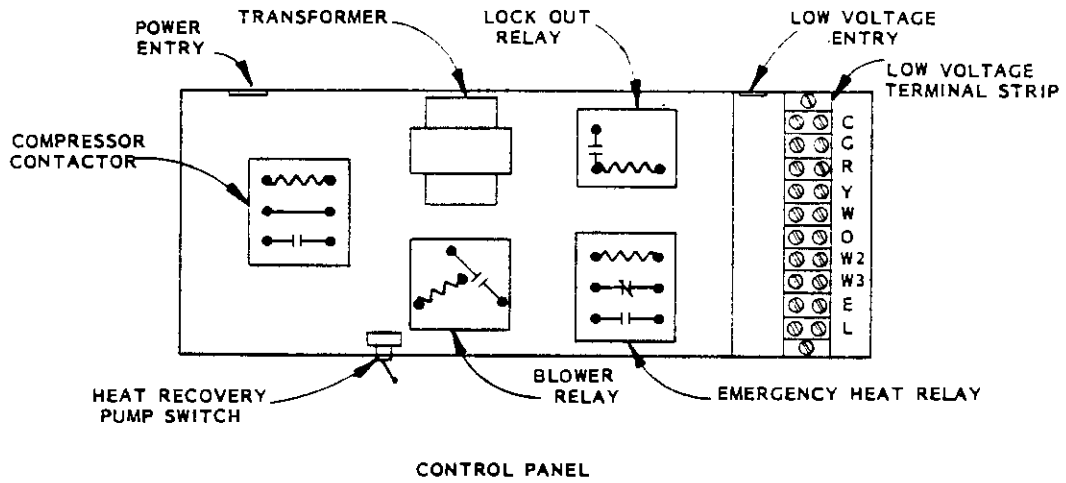

NOTE: If no return air duct is used, applicable installation codes may limit this cabinet to installation only in a single story structure.

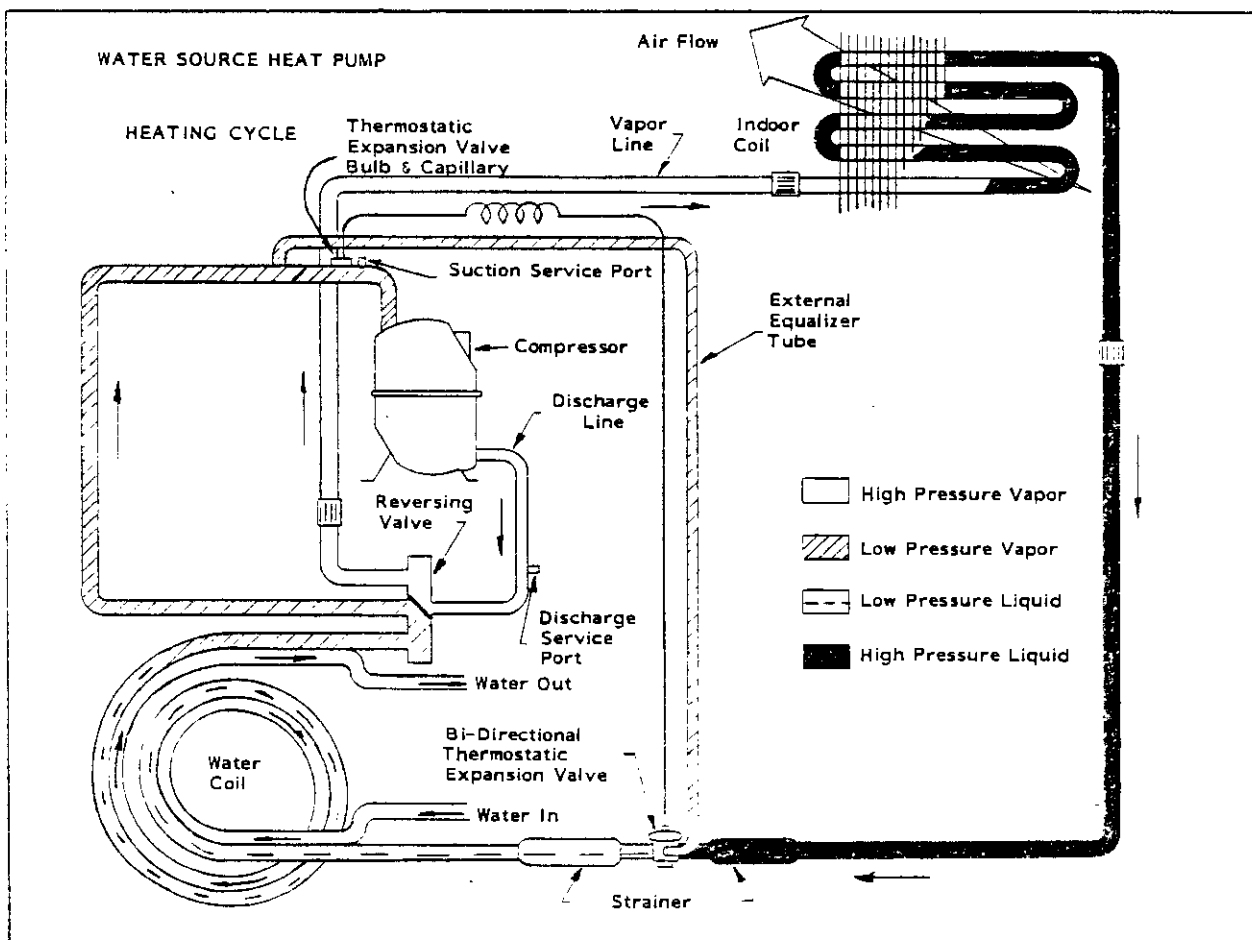
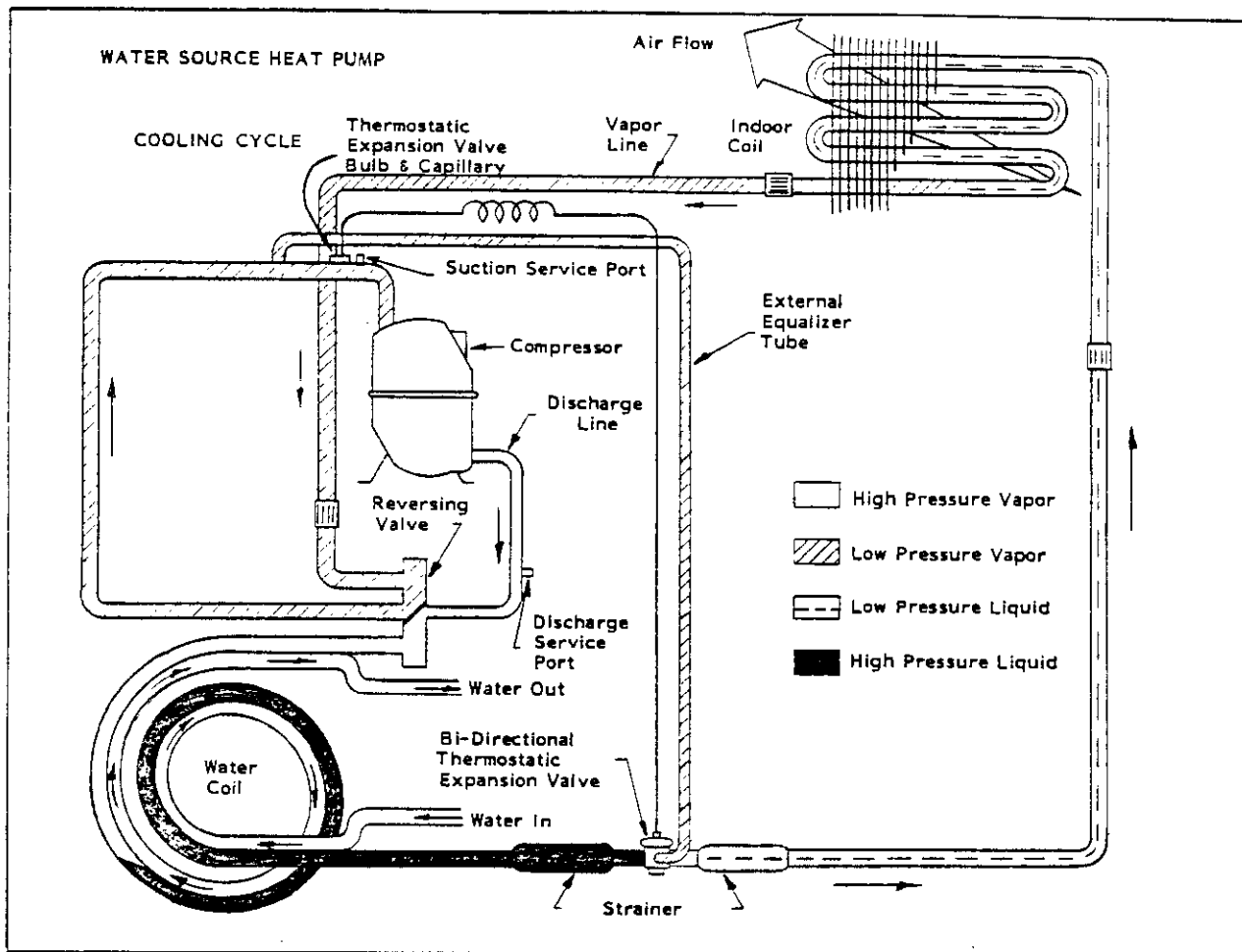

GENERAL

Units are shipped completely assembled and internally wired, requiring only duct connections, thermostat wiring, 230-208 volt AC power wiring, and water piping. The equipment covered in this manual is to be installed by trained, experienced service and installation technicians. Any heat pump is more critical of proper refrigerant charge and an adequate duct system than a cooling only air conditioning unit.

These instructions and any instructions packaged with any separate equipment required to make up the entire heat pump system should be carefully read before beginning the installation. Note particularly any tags and/or labels attached to the equipment.

While these instructions are intended as a general recommended guide, they do not in any way supersede any national and/or local codes. Authorities having jurisdiction should be consulted before the installation is made.

UNPACKING

Upon receipt of the equipment, the carton should be checked for external signs of shipping damage. If damage is found, the receiving party must contact the last carrier immediately, preferably in writing, requesting inspection by the carrier's agent.

INSTALLATION

1. BTUH CAPACITY SELECTION

Capacity of the unit for a proposed installation should be based on heat loss calculations made in accordance with methods of the Air Conditioning Contractors of America, formerly National Warm Air Heating and Air Conditioning Association. The air duct system should be sized and installed in accordance with Standards of the National Fire Protection Association For The Installation of Air Conditioning and Ventilating Systems of Other Than Residence Type NFPA No. 90A, and Residence Type Warm Air Heating and Air Conditioning Systems, NFPA No. 90B.

2. SITE SELECTION

The unit may be installed in a basement, crawlspace or attic provided adequate service access is insured. The unit should be located in the conditioned space to prevent freezing of the water lines.

Clearance to combustible materials is 0 inches for the heat pump. If an optional duct heater is installed, follow the instructions packed with the duct heater for specifications regarding clearance to combustible material.

Before setting the unit, consider ease of piping, drain and electrical connections for the unit. Also, for units with heat recovery unit, consider the proximity of the unit to the water heater or storage tank.

3. SUPPLY AND RETURN DUCT LOCATIONS ON UNIT

Refer to Figure 3. The unit's supply and return air connections can be arranged in six different configurations. To change from left-hand return (shipping mode) to right-hand return, remove the return air panel, turn the panel around and install it on the opposite side of the unit over the return air opening. Install optional filter rack or duct work using the holes provided. To change the direction of blower discharge, remove the blower access panels. Remove the bolt holding the blower assembly, lift blower out of the bottom offset. Remove the blower discharge panel (panel with air opening and plenum flanges) and install it into either the left-hand or right-hand opening. Replace blower into its new position by inserting blower bottom flange into the bottom offset and aligning upper flange bolt hole with the hole provided and tightening the bolt. Replace blower access panels. Place the unit on a solid base to minimize undesirable noise and vibration. DO NOT elevate the base pan on rubber or cork vibration eliminator pads as this will permit the unit base to act like a drum, transmitting objectionable noise.

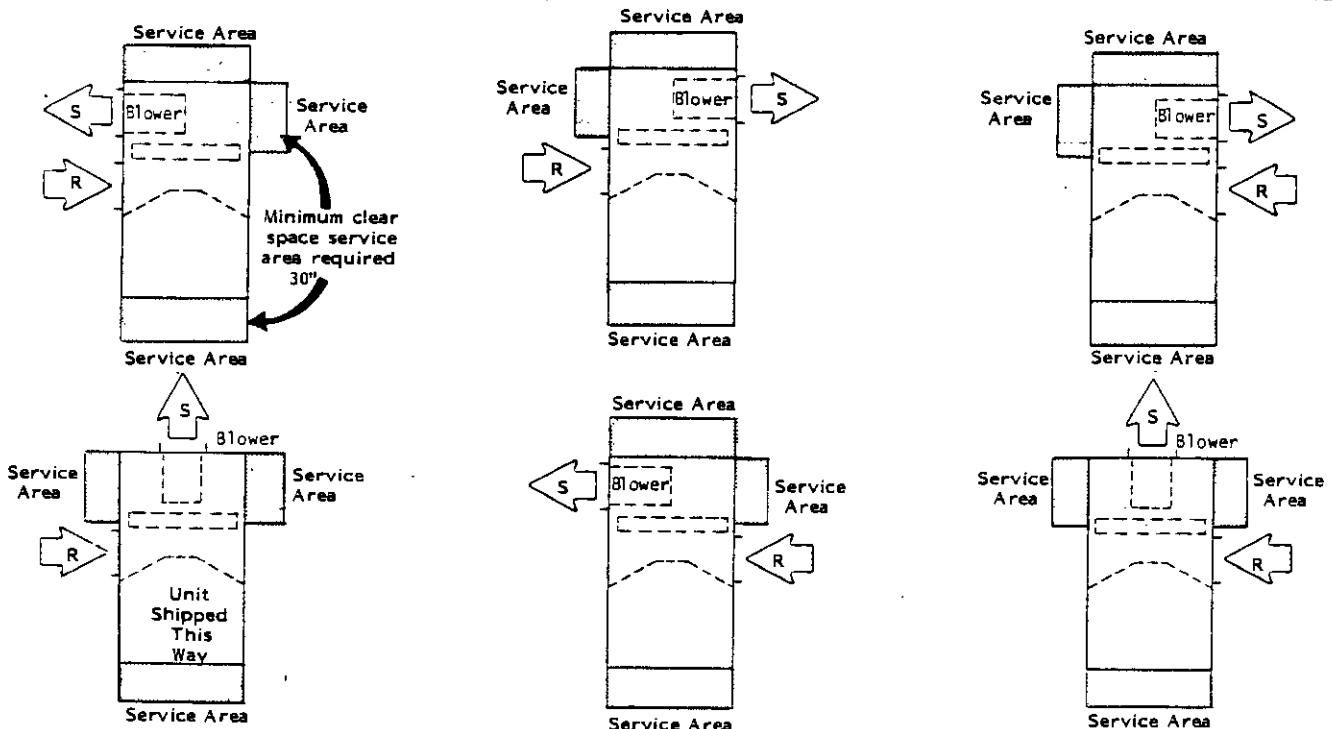

← S Supply air from unit.
← R Return air from unit.

FIGURE 3

4. DUCTWORK

If the unit is to be installed in a crawlspace or attic, a secondary drain pan, with overflow drain connection, under the entire unit is highly recommended.

DO NOT install the unit in such a way that a direct path exists between any return grille and the unit. Rather, insure that the air entering the return grille will make at least one turn before entering the unit air coil. This will reduce possible objectionable compressor and air noise from entering the occupied space.

Design the ductwork according to methods given by the National Warm Air Heating and Air Conditioning Association. When duct runs through unconditioned spaces, it should be insulated with a minimum of two inches fiberglass insulation with vapor barrier. It is recommended that flexible connections be used to connect the ductwork to the unit in order to keep the noise transmission to a minimum.

5. FILTER (Filter Rack Optional)

This unit must not be operated without a filter or filter grilles. Optional filter rack with a disposable filter should be checked often and replaced if dirty. Insufficient air flow due to undersized duct systems or dirty filters can result in nuisance tripping of the high or low pressure controls. Refer to Table 3 for correct air flow and static pressure requirements. See Figure 4 for optional filter rack assembly and installation.

6. ELECTRICAL WIRING

All electrical connections are made through the side of the unit. High voltage connections are made to the compressor contactor. Low voltage connections are made to the terminal strip mounted in the control panel. Refer to the wiring diagram for connecting the terminals.

a. MAIN POWER

Refer to the unit serial plate for wire sizing information and correct overcurrent protection size. Each unit is marked with a "Minimum Circuit Ampacity". This means that field wiring connectors must be sized to carry that amount of current. Each unit and/or wiring diagram is also marked "Use Copper Conductors Only" meaning the leads provided are not suitable for aluminum wiring. Refer to the National Electric Code for complete current-carrying capacity data on the various grades of wiring material.

The unit rating plate lists "maximum Overcurrent Protective Device" that is to be used with the equipment. This device may be a time delay fuse or HACR Type circuit breaker. The correct size overcurrent protective device must be used to provide for proper circuit protection and to avoid nuisance trips due to the momentary high starting current of the compressor motor.

b. CONTROL CIRCUIT--LOW VOLTAGE WIRING

A 24 volt terminal strip is mounted in the control panel. Two types of thermostats are available: 1) Single stage heat, single stage cool to operate the heat pump alone--without backup duct style electric heaters. This thermostat is equipped with a signal light to indicate when the unit is "locked out" because of the low or high pressure control. Refer to the wiring diagrams at the end of this manual for correct connection of the terminals. 2) Two stage heat, single stage cool to operate the heat pump or duct heaters on heating or the heat pump on cooling. This thermostat is also equipped with a signal light to indicate when the unit is "locked out" because of operation of the low or high pressure control. In addition, a second signal light tells when the unit has been placed in Emergency Heat. Refer to the wiring diagram at the end of this manual and to the wiring diagram packed with the duct heater for correct connection of the low voltage terminals.

7. CONDENSATE DRAIN

Determine where the drain line will run. This drain line contains cold water and must be insulated to avoid drops of water from dropping on ceiling, etc. A trap must be installed in the primary drain line.

For installations with auxiliary drain pan, a separate drain line should be run from the auxiliary drain pan and terminated where the homeowner can see it. Be certain to show the homeowner the location of the drain line and to explain its purpose. In the event of overflow of primary drain, water will collect in auxiliary pan and run out through the auxiliary drain line.

It is not recommended that any condensate drain lines be connected to a sewer main. Drain lines must be installed in accordance with local codes.

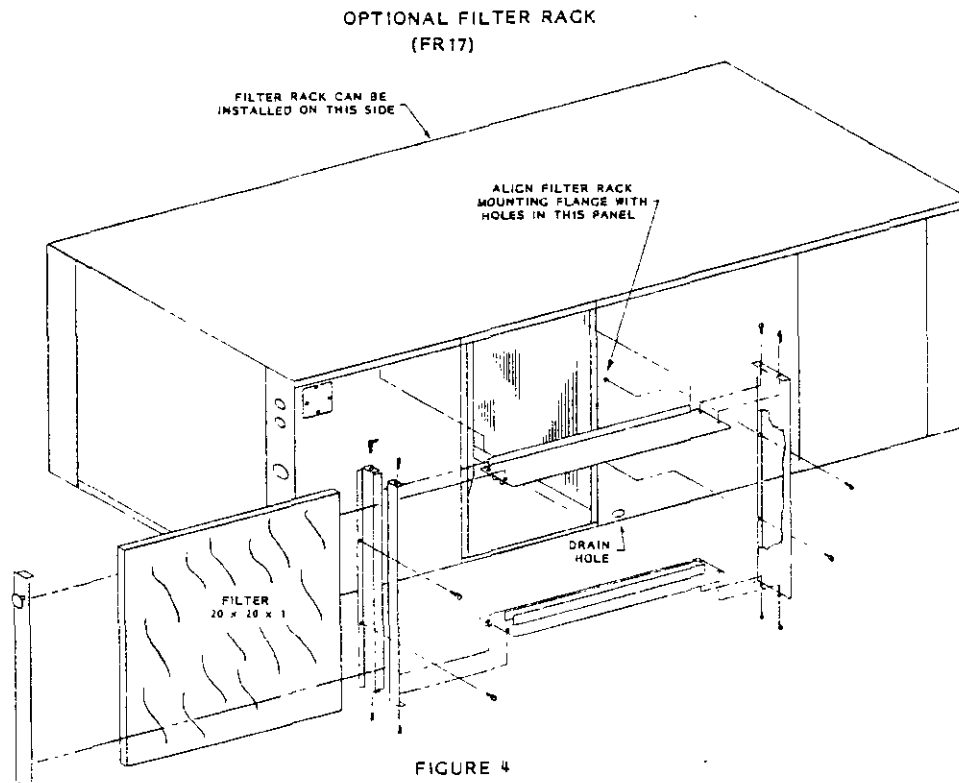

8. PIPING ACCESS TO THE UNIT

Water piping to and from the unit enters the unit casing through the water access panel. Piping connections are made to lengths of 1" hose which connect to the heat exchanger.

9. WATER CONNECTIONS

It is very important that an adequate supply of clean non-corrosive water at the proper pressure be provided before the installation is made. Insufficient water, in the heating mode for example, will cause the low pressure control to trip, shutting down the heat pump. In assessing the capacity of the water system, it is advisable that the complete water system be evaluated to prevent possible lack of water or water pressure at various household fixtures whenever the heat pump turns on. All plumbing to and from the unit is to be installed in accordance with local plumbing codes. The use of plastic pipe, where permissible, is recommended to prevent electrolytic corrosion of the water pipe. Because of the relatively cold temperatures encountered with well water, it is strongly recommended that the water lines connecting the unit be insulated to prevent water droplets from condensing on the pipe surface.

Refer to Piping, Figure 5. Slow closing Solenoid Valve (6) with a 24V coil provides on/off control of the water flow to the unit. Refer to the wiring diagram for correct hookup of the valve solenoid coil.

Constant Flow Valve (7) provides correct flow of water to the unit regardless of variations in water pressure. Observe the water flow direction indicated by the arrow on the side of the valve body. Following is a table showing which valve is to be installed with which heat pump.

HEAT PUMP MODEL	FLOW RATE	PART NUMBER
HWP30 HWP30	4 GPM	8603-010
HWP36 HWP36	5 GPM	8603-011

Strainer (5) installed upstream of constant flow valve (7) to collect foreign material which would clog the flow valve orifice.

The figure shows the use of shutoff valves (9) and (11), on the in and out water lines to permit isolation of the unit from the plumbing system should future service work require this. Globe valves should not be used as shutoff valves because of the excessive pressure drop inherent in the valve design. Instead use gate or ball valves as shutoffs so as to minimize pressure drop.

Drain Cocks (8) and (10), and tees have been included to permit acid cleaning the refrigerant-to-water coil should such cleaning be required. See WATER CORROSION.

Drain Cock (12) provides access to the system to check water flow through the constant flow valve to insure adequate water flow through the unit. A water meter 1-10 GPM (8603-013) is used to check the water flow rate. See photo #1.

10. WELL PUMP SIZING

Strictly speaking, sizing the well pump is the responsibility of the well drilling contractor. It is important, however, that the HVAC contractor be familiar with the factors that determine what size pump will be required. Rule of thumb estimates will invariably lead to under or oversized well pumps. Undersizing the pump will result in inadequate water to the whole plumbing system but with especially bad results to the heat pump—NO HEAT/NO COOL calls will result. Oversized pumps will short cycle and could cause premature pump motor or switch failure.

The well pump must be capable of supplying enough water and at an adequate pressure to meet competing demands of water fixtures. The well pump must be sized in such a way that three requirements are met:

1. Adequate flow rate in GPM.
2. Adequate pressure at the fixture.
3. Able to meet the above from the depth of the well—feet of lift.

The pressure requirements put on the pump are directly affected by the diameter of pipe being used as well as by the water flow rate through the pipe. The worksheet included in Manual 2100-078 should guarantee that the well pump has enough capacity. It should also ensure that the piping is not undersized which would create too much pressure due to friction loss. High pressure losses due to undersized pipe will reduce efficiency and require larger pumps and could also create water noise problems.

11. POND INSTALLATIONS

When pond water is used as the water supply and heat sink for these units, the following is recommended:

- a. The pond must be large enough to ensure a minimum entering water temperature of 37°F for the unit to operate in the heating mode.
- b. The pond must be large enough to ensure a maximum entering water temperature of 105°F for the unit to operate in the cooling mode.
- c. A water flow rate of 12 GPM or greater is required for all models.
- d. Place inlet and outlet pipes far enough apart from each other to prevent thermal interference between the supply and return water.
- e. Screen over intake and discharge pipes.
- f. Intake water should be below the 15 foot level in the pond.

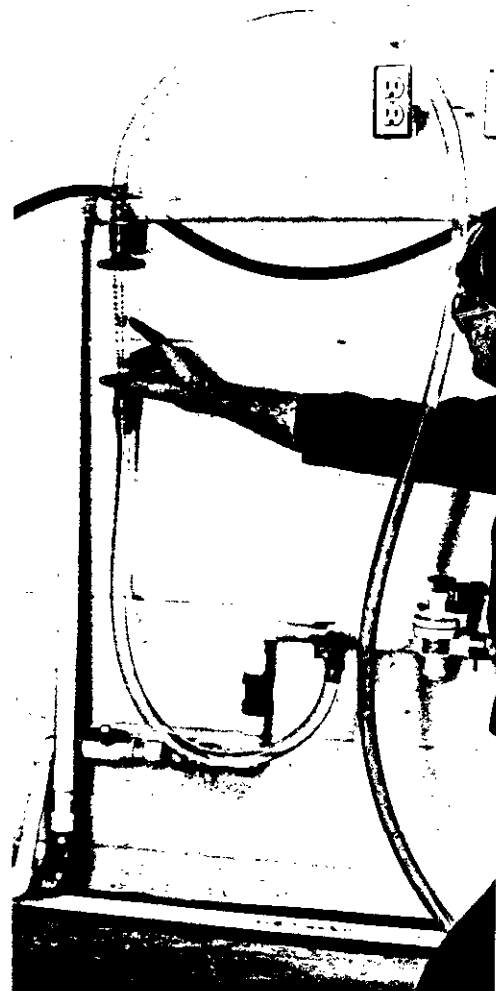

PHOTO NO. 1

Measuring typical water flow through a water source heat pump using a water flow meter (8603-013) to ensure proper water flow through unit.

SEQUENCE OF OPERATION

1. COOLING WITH OR WITHOUT DUCT HEATERS

Whenever the system lever is moved to COOL, thermostat system switch completes a circuit R to O, energizing the reversing valve solenoid. On a call for cooling, the cooling bulb completes a circuit from R to G, energizing the blower relay coil. The blower relay contacts complete a 230 volt circuit to the blower motor and the blower operates. R to Y circuit is completed at the same time as the fan circuit and current flows from Y to terminal 4 at the lockout relay. Terminal 4 of the lockout relay provides two paths for current flow.

1. Through the lockout relay coil which offers the resistance of the lockout relay coil.
2. Through the normally closed contacts of the lockout relay to terminal 5 of the lockout relay and then through the high and low pressure switches to the compressor contactor coil.

If the high and low pressure switches remain closed (refrigerant pressure remains normal), the path of least resistance is through these safety controls to the compressor contactor coil. The contacts of the compressor contactor complete a 230 volt circuit to the compressor and the compressor runs. If discharge (suction) pressure reaches the set point of the high (low) pressure control, the normally closed contacts of the high (low) pressure control open and current no longer flows to the compressor contactor coil--the coil drops out. Current now can take the path of least resistance through the lockout relay coil, energizing the lockout relay coil and opening terminals 4 and 5 of the lockout relay. The lockout relay will remain energized as long as a circuit is completed between R and Y at the thermostat. In the meantime, since the compressor is not operating, refrigerant pressure will equalize and the high (low) pressure switch will automatically reset. However, the circuit to the compressor contactor will not be complete until the lockout relay is de-energized by moving the thermostat system switch to OFF, breaking the circuit from R to Y, dropping out the lockout relay coil and permitting terminals 4 and 5 to make. When the high (low) pressure switch closes, a circuit is completed to L at the thermostat, energizing the signal light to indicate a malfunction. When the system switch is moved from OFF to COOL, the cycle is repeated.

2. SINGLE STAGE HEAT WITHOUT DUCT HEATERS

Compressor circuit R to Y including lockout relay and pressure controls is the same as cooling. Blower circuit R to G is the same as cooling. With system switch set to HEAT, no circuit is completed between R and O and reversing valve solenoid is not energized.

3. TWO STAGE HEAT WITH DUCT HEATERS

First stage heat is the same as single stage heating without duct heater. When the second stage thermostat bulb makes, a circuit is completed from R to W2, energizing the duct heater heat contactor, R1, through the automatic thermal cutout (TCO). The contacts of R1 close a circuit to the heat pump blower relay and, through the manual reset thermal cutoff device, to the elements. Elements and blower remain energized as long as R to W2 are made.

4. EMERGENCY HEAT

When the system switch is moved to EMER, the compressor circuit R to Y is disconnected. Control of the electric heaters is from R to W2 through the thermostat second stage heating bulb. Blower operation is controlled by the second stage heating bulb. Operation is the same as above, "Two Stage Heat With Duct Heaters."

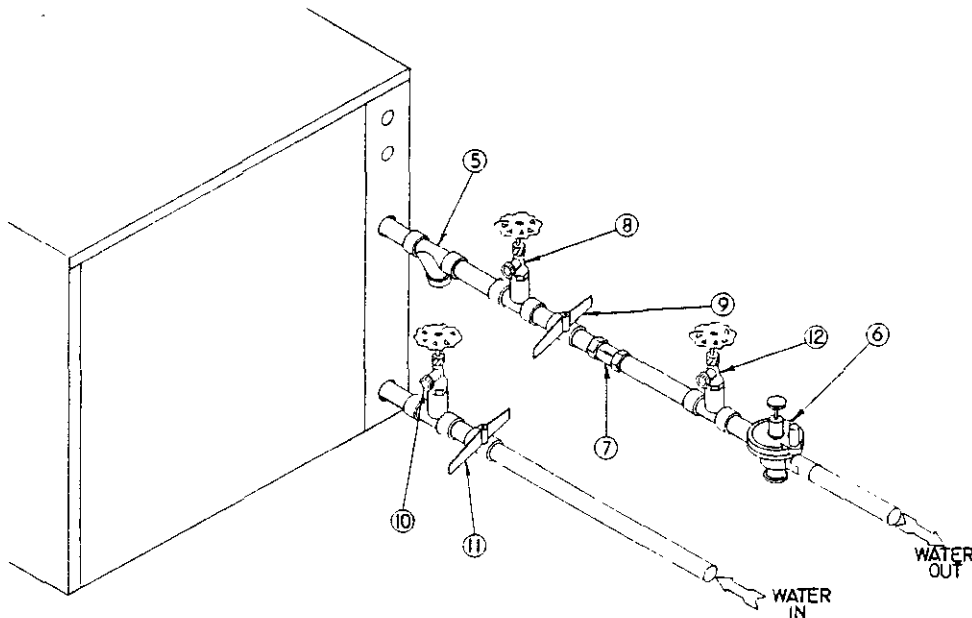

FIGURE 5

SYSTEM START UP PROCEDURE

1. Be sure main power to the unit is OFF at the disconnect.
2. Set thermostat system switch to OFF, fan switch to AUTO.
3. Move main power disconnect to ON. Power should be on to unit for a minimum of 4 hours or 60 minutes per pound of refrigerant. This allows the crankcase heater to drive any refrigerant liquid out of the compressor sump. This procedure should be followed whenever the power has been off for twelve hours or longer. Except as required for safety while servicing--DO NOT OPEN THE UNIT DISCONNECT SWITCH.
4. Check system air flow for obstructions.
 - a) Move thermostat fan switch to ON. Blower runs.
 - b) Be sure all registers and grilles are open.
 - c) Move thermostat fan switch to AUTO. Blower should stop.
5. Fully open the manual inlet and outlet valves.
6. Check water flow. (See Photo 1)
 - a) Connect a water flow meter to the drain cock (12, Fig.5) between the constant flow valve and the solenoid valve. Run a hose from the flow meter to a drain or sink. Open the drain cock.
 - b) Check the water flow rate through constant flow valve to be sure it is the same as the unit is rated for.
(Example: 4 GPM for a HWP30)
 - c) When water flow is okay, close drain cock and remove the water flow meter. The unit is now ready to start.
7. Start the unit in cooling mode by moving the thermostat switch to cool, fan should be set for AUTO.
 - a) Check to see the solenoid valve opened.
8. Check the system refrigerant pressures Δ against the cooling refrigerant pressure curves on page 12 and 13 of this manual for rated water flow and entering water temperatures. If the refrigerant pressures do not match, check for air flow problem then refrigeration system problem.
9. Switch the unit to the heating mode by moving the thermostat switch to heat, fan should be set for AUTO.
 - a) Check to see the solenoid valve opened again.
10. Check the refrigerant system pressures Δ against the heating refrigerant pressure curve in Installation Manual. Once again, if they do not match, check for air flow problems and then refrigeration system problems.

NOTE: If a charge problem is determined (high or low):

- a) Check for possible refrigerant leaks.
- b) Discharge all remaining refrigerant from unit.
- c) Evacuate unit down to 29 inches of vacuum.
- d) Recharge the unit with refrigerant by weight. This is the only way to insure a proper charge.

Δ For models with domestic hot water heat exchanger, be sure the water pump switch is off while checking refrigerant system.

GENERAL

Units having a heat recovery coil should only be installed by trained refrigeration technicians. These instructions serve as a guide to the technician installing the heat recovery portion of the unit. They are not intended as a step-by-step procedure with which the mechanically inclined owner can install the unit.

DESCRIPTION

Units with the heat recovery coil mounted at the factory are designed to recover the "waste" heat from the compressor discharge gas and use this "waste" heat to heat domestic hot water. Units so equipped may be identified by the letter "D" in the model number. In addition to the components already described for the heat pump, these units are equipped with an additional water-to-refrigerant coil, a circulating pump and a thermostat to control the operation of the circulating pump. The water-to-refrigerant coil is constructed of two tubes. Water flows through the center tube, totally separated from the water tube. The space between these two tubes is vented to atmosphere. In the unlikely event a leak should develop, no leakage can occur between the water and the refrigerant.

INSTALLATION

1. **TWO TANK.** In order to realize the maximum energy savings from the domestic hot water heat recovery unit, it is recommended that a second water storage tank be installed in addition to the main hot water heater. Fossil fuel fired water heaters must be a two tank installation. If the existing water heater is electric, the two tank installation is still the best approach, however, a one tank installation is satisfactory. Tanks specifically intended for hot water storage are available from water heater manufacturers (solar hot water storage tanks). These tanks have special dip tube arrangements, are built without heaters and are constructed with heavier insulation. However, a well insulated electric water heater without the electric heating elements connected will also make a suitable storage tank.

The size of this tank should be as large as space and economy permit but in no event should it be less than one-half of the daily water requirements for the occupants. As a guide in estimating the daily family water requirements, the Department of Energy recommends a figure of 16.07 gallons of hot water per day per individual. For example, a family of four would require 64.3 gallons per day (4 x 16.07).

2. **ONE TANK.** Where space or first cost economy dictates only one hot water heater, a single tank installation is permissible. It should be noted, however, that the amount of savings realized is reduced.

The single hot water tank may be a new hot water heater (sized in this case to 100% of daily water requirements) or the existing water heater in the case of a retrofit installation. The existing hot water heater should be carefully inspected and any sediment removed by draining the water heater and flushing it until all loose sediment has been flushed away. This sediment, besides cutting down on the efficiency of the water heater and heat recovery unit could damage the circulating pump, or clog the strainer and stop water flow.

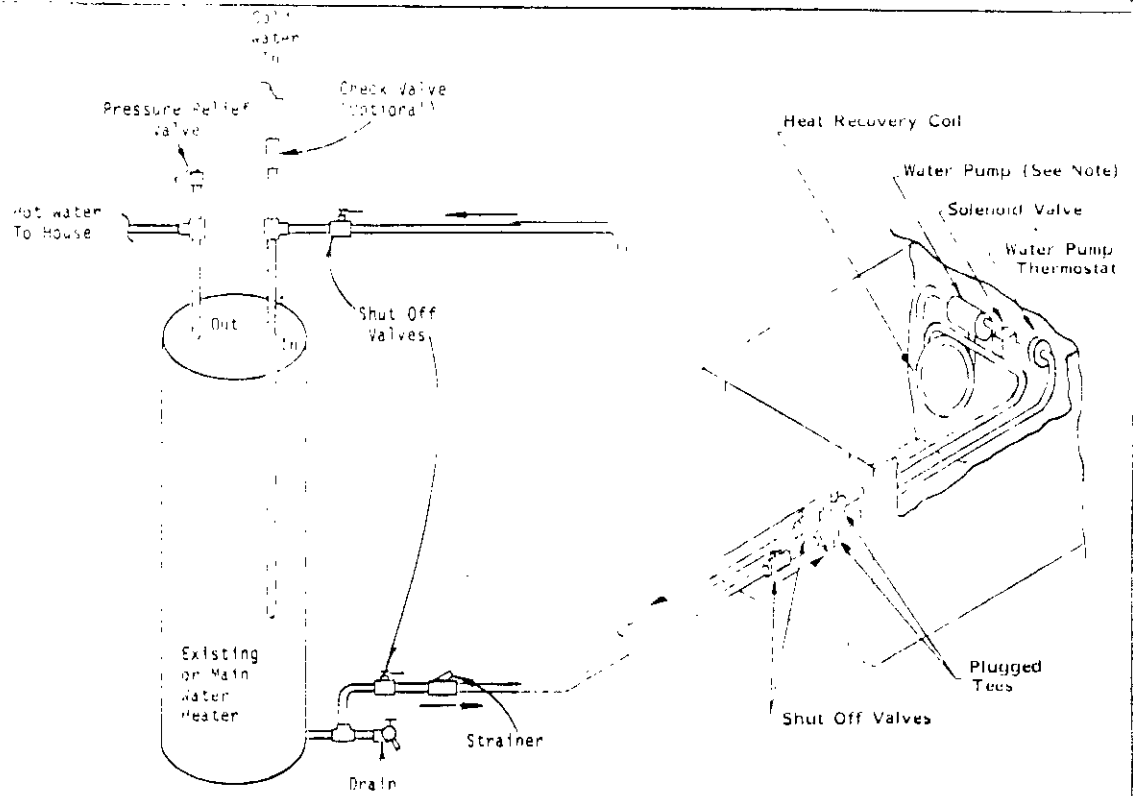

NOTE: Do not operate water pump without water lines connected and water in system with shut off valves open. Turn pump switch to off.

TYPICAL "HWPD" MODEL
ONE TANK INSTALLATION
(Permissible)

FIG. 8

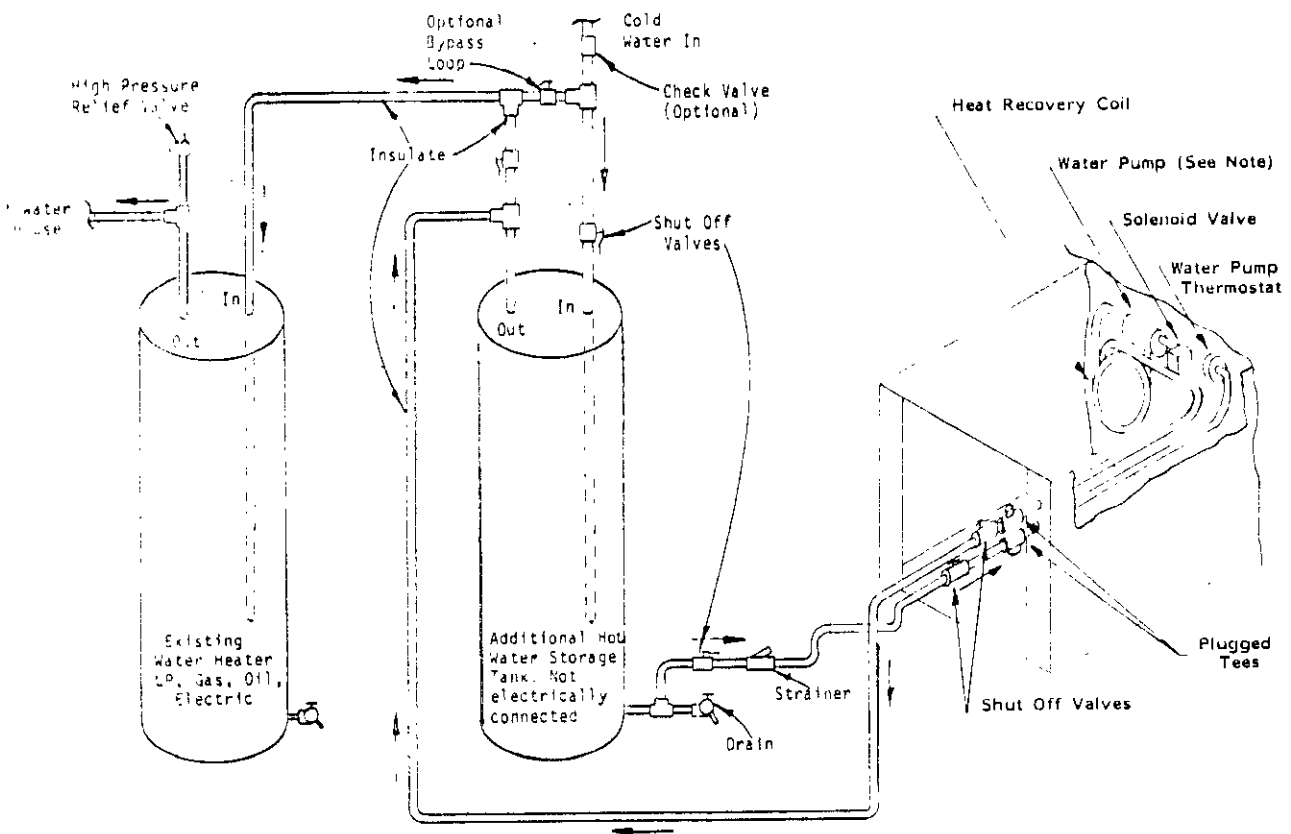

NOTE: Do not operate water pump without water lines connected and water in system with shut off valves open. Turn pump switch to off.

TYPICAL "HWPD" MODEL
TWO TANK INSTALLATION
(Preferred)

FIG. 7

LOCATION

In determining the location of the storage tank (and the water heater) keep in mind that small temperature differences between the storage tank water temperature and the refrigerant temperature permit this unit to function. It is consequently necessary that all tubing be kept as short and direct as possible and that the tubing be adequately and thoroughly insulated.

Locate the storage tank as close to the heat pump and water heater as the installation permits. Be sure to provide adequate service access to all components.

INSTALLATION PROCEDURE - GENERAL

1. Turn off the water heater electric power (if electric hot water heater) or close the fuel supply line (if fossil fuel water heater).

2. Turn off the electric power to the water source heat pump.

3. Shut off the main water supply line by closing the water valve at the well pressure tank (if a well system) or the water meter (if city water is being used for domestic purposes).

4. Connect a garden hose to the water heater drain valve (bottom of the water heater tank) and drain the water heater to a floor drain or other convenient drain.

5. If the water heater has been in service for some time, inspect it for sediment. Remove all sediment and thoroughly flush the water heater tank.

WATER PIPING

Two tank installation, refer to Piping Diagram, Fig. 7 and steps 1 to 3, and Two Tank installation instructions. One tank installation, refer to Piping Diagram, Fig. 8 and steps 1 to 3 and One Tank installation instructions. Follow all local plumbing codes. Piping connections are 1/2 inch O.D. copper pipe, Type K or L, and are made inside the unit. A removable 4x4 panel has been provided in the unit side to permit safely soldering the connections. Route the copper through the end of the heat pump through the holes provided.

1. A plugged tee and shut off valve should be provided near the heat pump unit. This will make it easy if it ever becomes necessary to clean the desuperheater coil. A suitable cleaner is mentioned below, "Water Corrosion" section. The shut off valves will isolate the unit from the rest of the plumbing and the plugged tees will provide access to the coil and pump for the cleaner.

2. A strainer is included in both figures to collect any sediment which may accumulate in the storage tank or water heater. This strainer should be of the cleanable "Y" type. It is more important that the strainer be included on one tank retrofit installation where the hot water heater may be suspected of sedimentation.

3. A check valve is shown in both figures as an option. The purpose of the check valve is to prevent any contamination of the water system in the unlikely event that the heat exchanger develops a leak. Check the local plumbing code as this check valve may be required.

TWO TANK INSTALLATION - FIGURE 7

1. Water into the heat recovery unit is taken from the bottom of the storage tank. This location will insure that the coldest water will always be circulated to the recovery unit.

2. If a solar type water storage tank is being used (specifically designed for storing but not heating water), insert the dip tubes according to the manufacturer's instructions.

3. If a second water heater is being used for storage, install a pipe thread tee and a suitably sized pipe nipple in the water heater drain connection (bottom of the tank). The run of the tee is connected between the water heater and a drain valve. Brass or bronze fittings are recommended for these fittings. Check the local plumbing code-- brass or bronze may be required. The branch of the tee is connected to the recovery unit "water in" copper tube. Use a pipe thread to sweat adapter to connect the tubing between the tee and recovery unit.

4. The "water out" tubing from the recovery unit is connected through a tee to the storage tank and to the normal "water in" of the main water heater.

5. Cold water into the storage tank is connected to the "water in" of the storage tank.

6. An optional bypass loop with valve is shown in Fig. 7 between the water into the storage tank and the "water out" of the storage tank. The loop will make future service work easier should it become necessary to drain the storage tank. In normal operation the valve in the bypass loop should be closed.

ONE TANK INSTALLATION -- FIGURE 8

NOT RECOMMENDED FOR FOSSIL FUEL FIRED WATER HEATER

1. Unless the single hot water heater is new, it should be thoroughly inspected and cleaned of sediment. Flush the tank several times and inspect it after each flushing. Be sure the tank is free of sedimentation.

2. Water from the hot water heater is connected to the domestic hot water supply as any conventional hot water heater would be connected.

3. Water to the heat recovery unit is connected through a tee at the drain valve connection of the hot water heater as described in step 3 above.

4. Water from the recovery unit is connected at the "water in" connection of the hot water heater through a tee.

OPERATION OF THE HEAT RECOVERY UNIT

The circulating pump and solenoid valve are wired in parallel with the heat pump compressor (230 VAC circuit). Thus, no water can be circulated to the water-to-refrigerant coil unless the compressor is in operation.

In addition, a thermostat, attached to the entering water tube of the pump, is wired in series with the pump motor and solenoid valve. The thermostat is normally closed and opens when the tube temperature reaches 150°F. This will stop further heating of the water by the recovery unit and is intended to prevent overheating the water. The thermostat will reset at approximately 120°F.

Heat for domestic hot water is obtained from the discharge gas of the compressor. This heat would ordinarily be rejected to the ground water in the cooling mode or to the room air in the heating mode. With the recovery unit this heat is transferred to the storage tank or water heater.

START UP AND CHECK OUT

1. Be sure all shut off valves are open. If optional bypass valve, See Fig. 7, has been installed, this valve should be closed.

2. Open a hot water faucet to permit any air to bleed from the plumbing.

3. Turn off the heat pump disconnect.

4. Temporarily remove compressor wire from load side of contactor and insulate.

5. Turn heat pump disconnect ON.

6. Set the wall thermostat to cool.

7. Inspect for water leaks and verify pump is operating.

8. Again turn off the heat pump disconnect.

9. Re-install compressor wire on compressor contactor terminal.

10. Repeat steps 5 and 6. Feel the "water in" and "water out" tubes. There should be a noticeable temperature difference. How much temperature difference you measure will depend upon tubing length, flow rate, storage tank temperature and could vary from 2°F to 20°F.

11. Move thermostat system to OFF. Verify that water pump stops.

WATER CORROSION

Two concerns will immediately come to light when considering a water source heat pump, whether for ground water or for a closed loop application: Will there be enough water? And, how will the water quality affect the system?

Water quantity is an important consideration and one which is easily determined. The well driller must perform a pump down test on the well according to methods described by the National Well Water Association. This test, if performed correctly, will provide information on the rate of flow and on the capacity of the well. It is important to consider the overall capacity of the well when thinking about a water source heat pump because the heat pump may be required to run for extended periods of time.

The second concern, about water quality, is equally important. Generally speaking, if the water is not offensive for drinking purposes, it should pose no problem for the heat pump. The well driller or local water softening company can perform tests which will determine the chemical properties of the well water.

Water quality problems will show up in the heat pump in one or more of the following ways:

1. Decrease in water flow through the unit.
2. Decreased heat transfer of the water coil (entering to leaving water temperature difference is less).

There are four main water quality problems associated with ground water. These are:

(1) Biological growth. This is the growth of microscopic organisms in the water and will show up as a slimy deposit throughout the water system. Shock treatment of the well is usually required and this is best left up to the well driller. The treatment consists of injecting chlorine into the well casing and flushing the system until all growth is removed.

(2) Suspended particles in the water. Filtering will usually remove most suspended particles (fine sand, small gravel) from the water. The problem with suspended particles in the water is that it will erode metal parts, pumps, heat transfer coils, etc. So long as the filter is cleaned and periodically maintained, suspended particles should pose no serious problem. Consult with your well driller.

(3) Corrosion of metal. Corrosion of metal parts results from either highly corrosive water (acid water, generally not the case with ground water) or galvanic reaction between dissimilar metals in the presence of water. By using plastic plumbing or di-electric unions galvanic reaction is eliminated. The use of corrosion resistant materials (such as the Cupro Nickel coil) throughout the water system will reduce corrosion problems significantly.

(4) Scale formation. Of all the water problems, the formation of scale by ground water is by far the most common. Usually this scale is due to the formation of calcium carbonate but magnesium carbonate or calcium sulfate may also be present. Carbon dioxide gas (CO_2) the carbonate of calcium and magnesium carbonate, is very soluble in water. It will remain dissolved in the water until some outside factor upsets the balance. This outside influence may be a large change in water temperature or pressure. When this happens, enough carbon dioxide gas combines with dissolved calcium or magnesium in the water and falls out of solution until a new balance is reached. The change in temperature that this heat pump produces is usually not high enough to cause the dissolved gas to fall out of solution. Likewise if pressure drops are kept to a reasonable level, no precipitation or carbon dioxide should occur.

REMEDIES OF WATER PROBLEMS

WATER TREATMENT. Water treatment can usually be economically justified for closed loop systems. However, because of the large amounts of water involved with a ground water heat pump, water treatment is generally too expensive.

ACID CLEANING THE WATER COIL OR HEAT RECOVERY UNIT.

If scaling of the coil is strongly suspected, the coil can be cleaned up with a solution of Phosphoric Acid (food grade acid). Follow the manufacturer's directions for mixing, use, etc. Refer to the "Cleaning Water Coil," Fig. 9. The acid solution can be introduced into the heat pump coil through the hose bib (Part 8 of Fig. 9). Be sure the isolation valves (Parts 9 and 11 of Fig. 9) are closed to prevent contamination of the rest of the system by the coil. The acid should be pumped from a bucket into the hose bib (Part 8, Fig. 9) and returned to the bucket through the other hose bib (Part 10, Fig. 9). Follow the manufacturer's directions for the product used as to how long the solution is to be circulated, but it is usually circulated for a period of several hours.

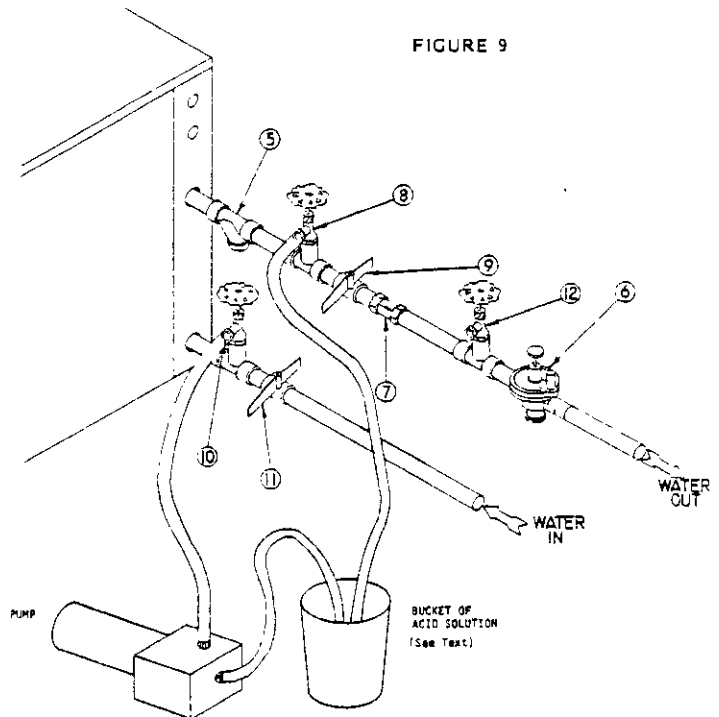

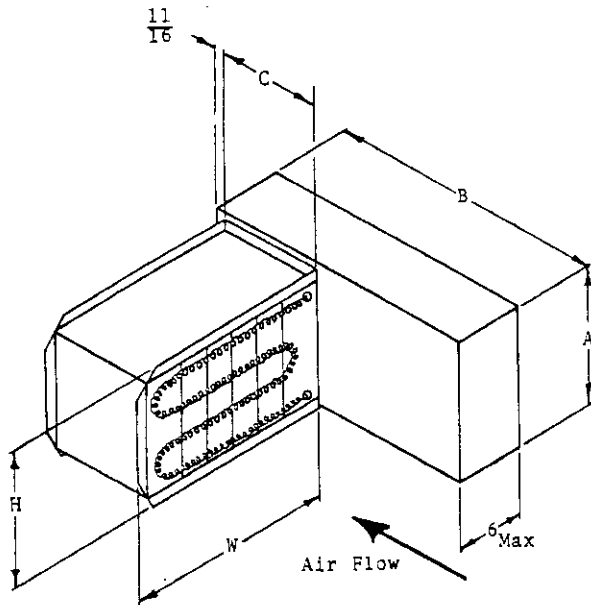

Model	HWP30-HWPD30		HWP36-HWPD36	
	GPM	PSIG	Ft. Hd.	PSIG
4	2.0	4.6	1.9	4.4
5	3.0	6.9	2.0	4.6
6	4.2	10.0	2.4	5.5
7	5.7	13.1	3.0	6.9
8	7.5	17.3	3.9	9.0
9	9.5	21.9	5.5	12.7
10	12.0	27.7	7.6	17.5
11	14.8	34.1	10.4	24.0
12	17.6	40.6	15.3	35.3
13	20.3	46.8	20.6	47.5

PART NO.	PH	VOLTS	KW	MINIMUM AMPACITY	WIRE SIZE ¹		MAX. FUSE	DIMENSIONS			
					Cu	Al		H&A	W	B	C
8604-067	1	240	4.8	25	#10	#8	25	8	12	17	6
8604-068	1	240	9.6	50	#6	#4	50	8	16	17	6
8604-069 ²	1	240	15.0	79	#3	#1	80	12	18	27	12
8604-070 ²	1	240	19.2	100	#1	#0	100	12	18	27	12

¹ Use wire suitable for at least 90°C.
² Fused units (over 48 amperes).

MODEL	GPM
HWP30 HWPD30	4
HWP36 HWPD36	5

E.S.P. In H ₂ O	HWP30	HWP36
	HWPD30	HWPD36
	Motor Speed	Motor Speed
	Low	High
.00	1140	1340
.10	1120	1300
.20	1090	1260
.30	1055	1215
.40	1015	1160
.50	975	1100
.60	930	1035

*Filter included. See unit specifications for rated CFM

MODEL	RATED CFM	RECOMMENDED AIR FLOW RANGE— CFM
HWP30 HWPD30	1000	900 - 1100
HWP36 HWPD36	1200	1080 - 1320

PART NO.	MIN. AVAILABLE PRESSURE PSIG	FLOW RATE GPM
8603-010	15 ¹	4
8603-011	15 ¹	5

¹ The pressure drop through the constant flow valve will vary depending on the available pressure ahead of the valve. Unless a minimum of 15 psig is available immediately ahead of the valve no water will flow.

These curves are based upon 80°DB, 67°WB R.A. Temp. and Rated CFM (airflow) for cooling and 70°DB for heating and should be used for reference purposes only. If there is any doubt as to correct operating charge being in the system, the charge should be removed, system evacuated, and recharged according to serial plate instructions.

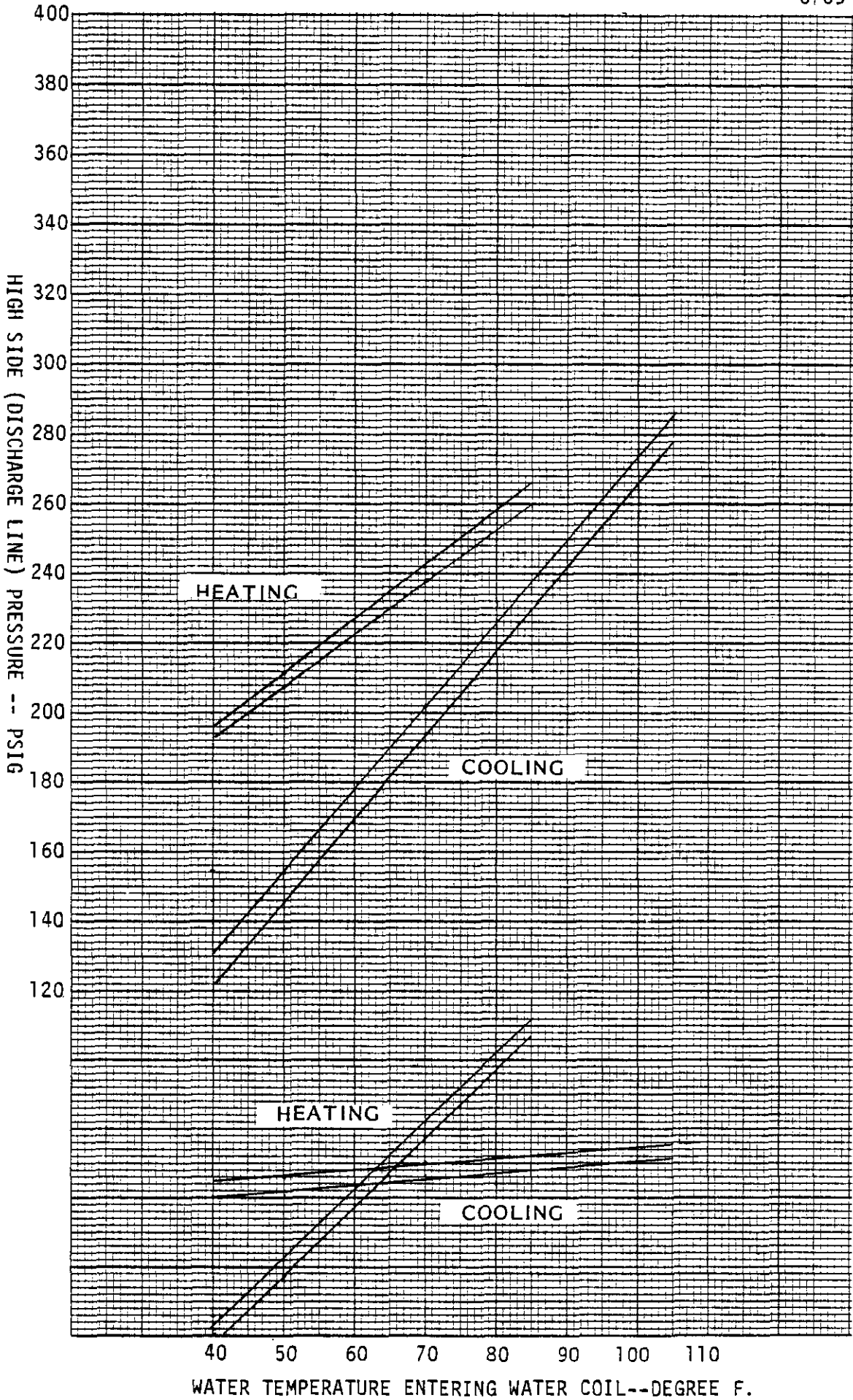

NOTE: On units with heat recovery coil (HWP30) turn water pump switch to "off" before measuring refrigerant pressures.

LOW SIDE PRESSURE--PSIG (SUCTION LINE)

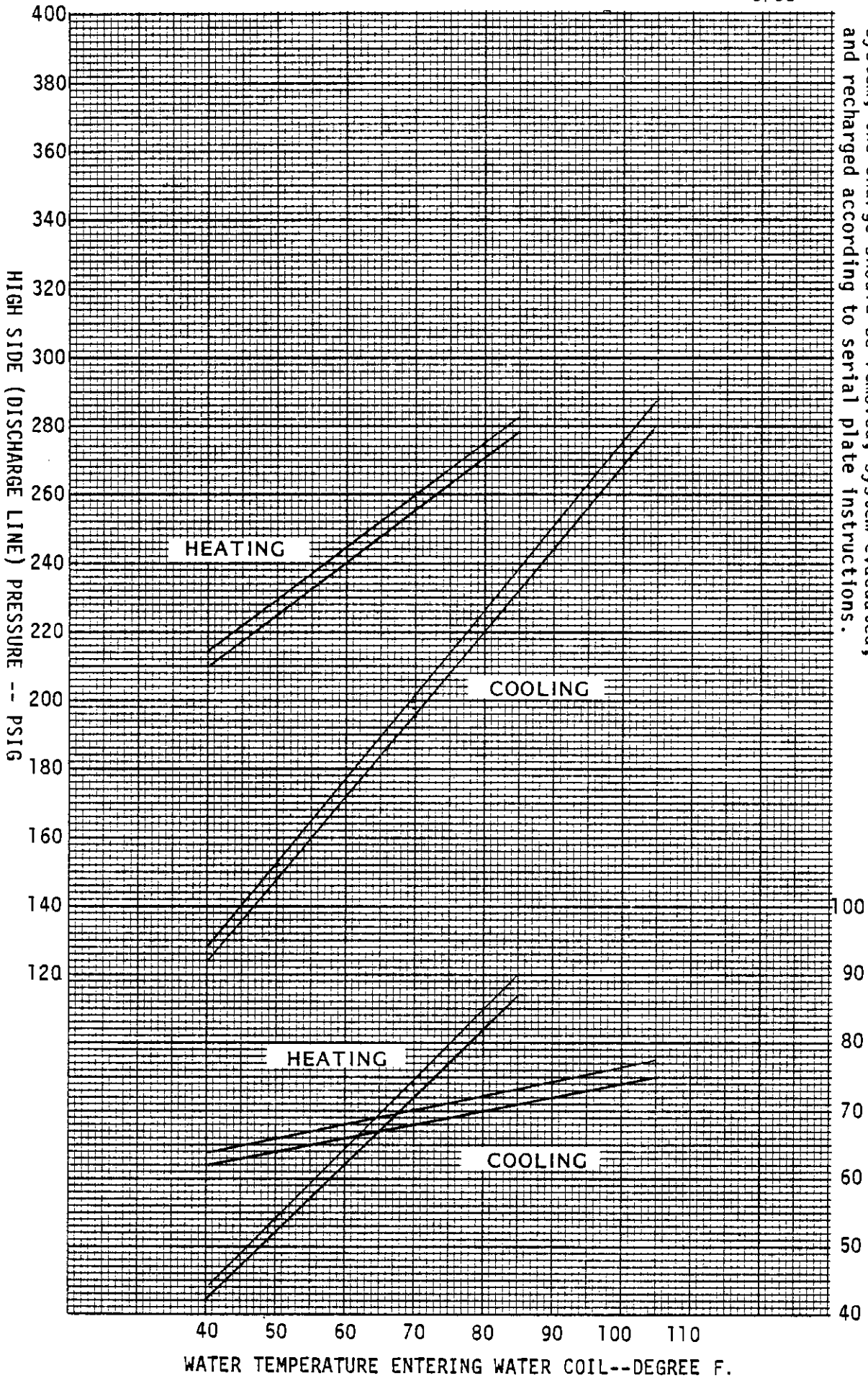

These curves are based upon 80°DB, 67°WB R.A. Temp. and Rated CFM (airflow) for cooling and 70°DB for heating and should be used for reference purposes only. If there is any doubt as to correct operating charge being in the system, the charge should be removed, system evacuated, and recharged according to serial plate instructions.

NOTE: On units with heat recovery coil (HWP36), turn water pump switch to "off" before measuring refrigerant pressures.

LOW SIDE PRESSURE--PSIG (SUCTION LINE)

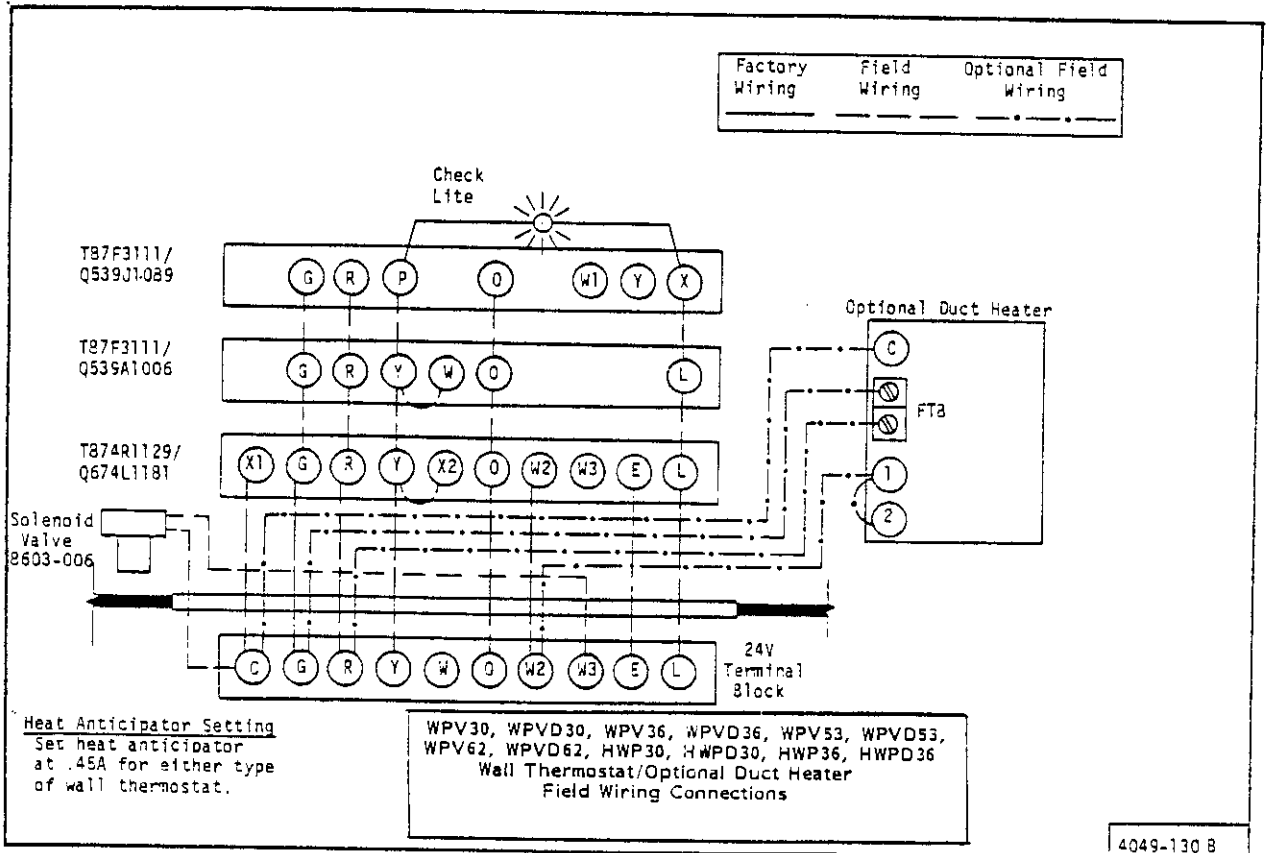
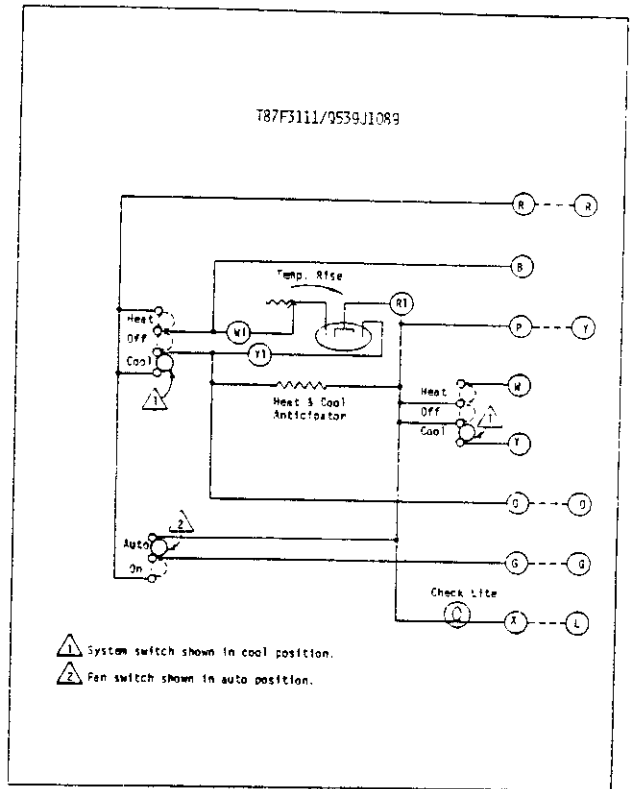
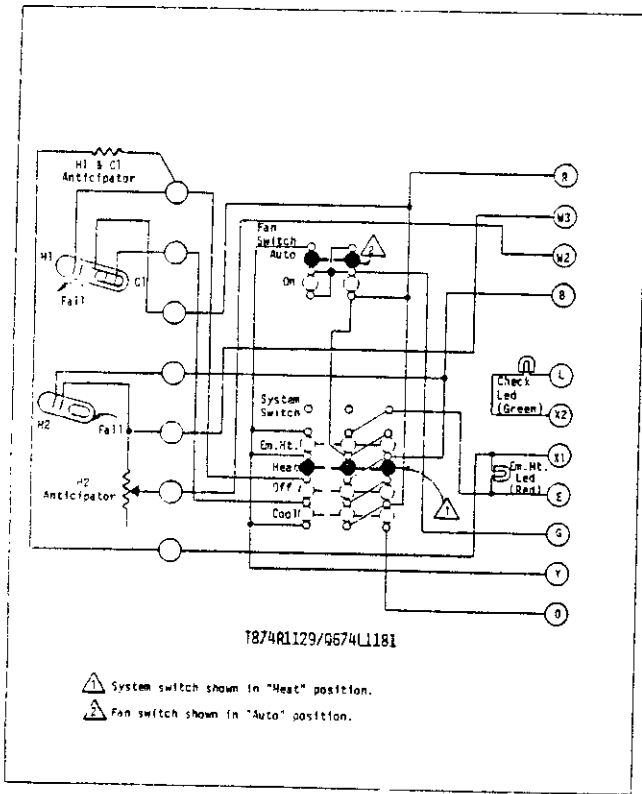

230/208-60-1

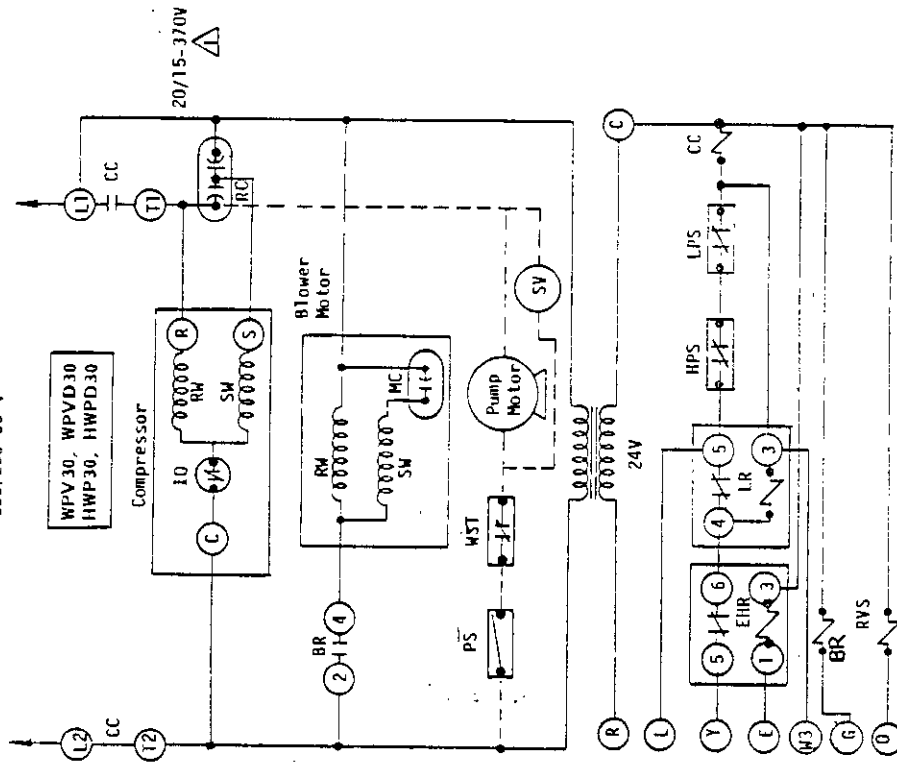

4049-800 B

230/208-60-1

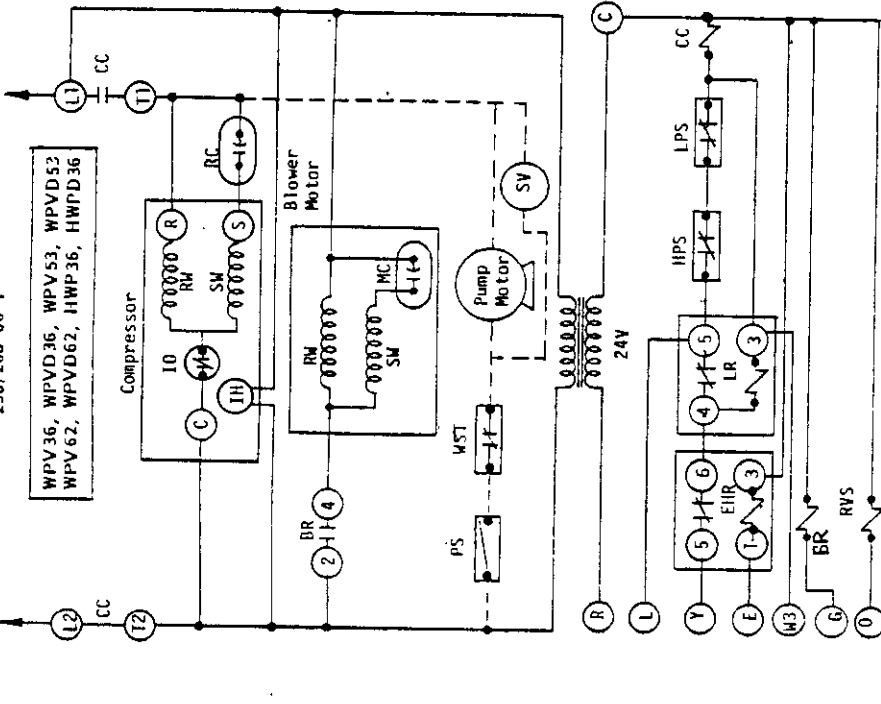

4049-800 B

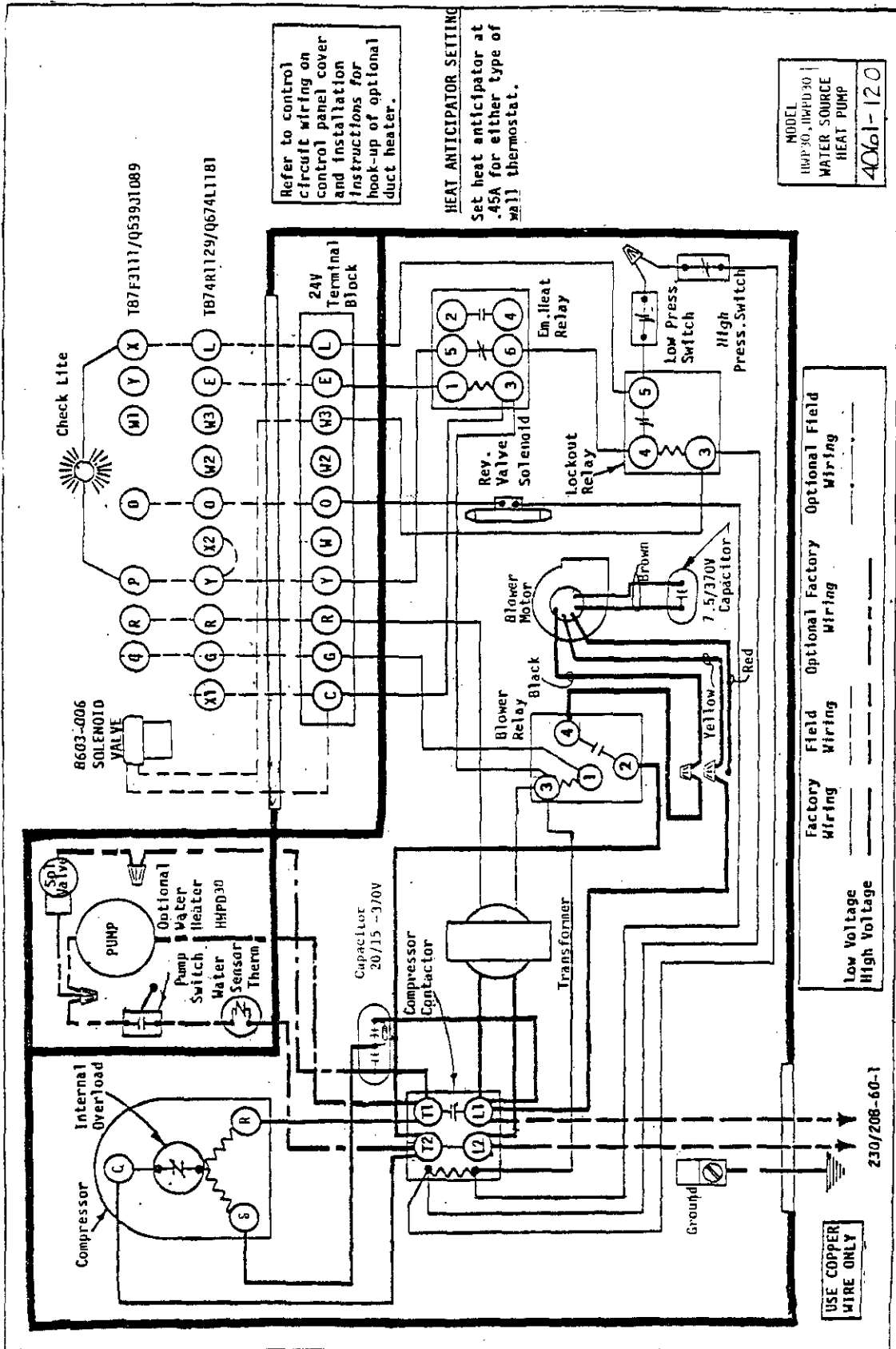

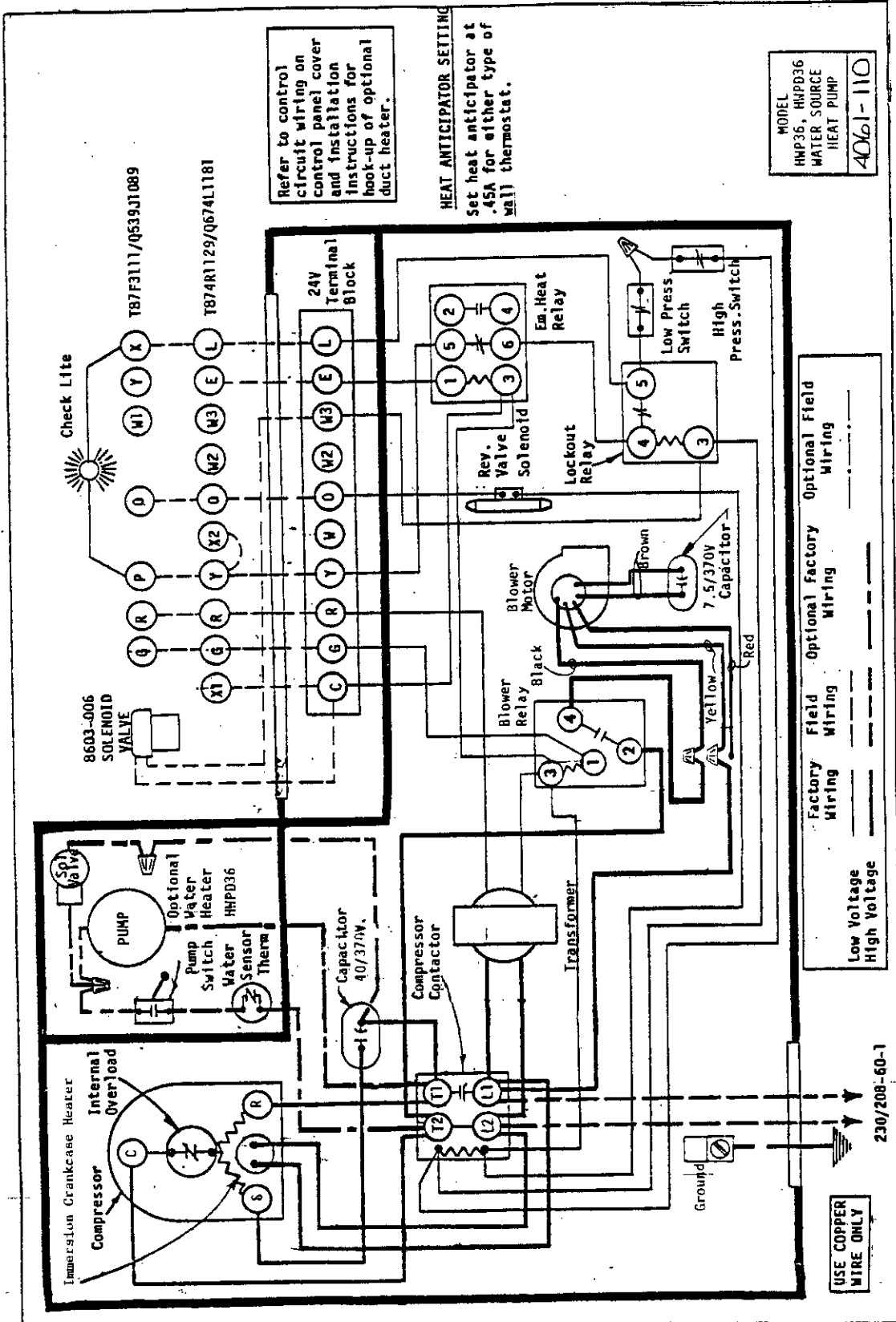

Refer to control circuit wiring on control panel cover and instructions for hook-up of optional duct heater.

HEAT ANTICIPATOR SETTING
 Set heat anticipator at .45A for either type of wall thermostat.

MODEL
 HMP36, HMPD36
 WATER SOURCE
 HEAT PUMP
 4061-110

Factory Wiring _____
 Field Wiring _____
 Optional Factory Wiring _____
 Optional Field Wiring _____

USE COPPER WIRE ONLY

230/208-60-1
 Low Voltage
 High Voltage

PERFORMANCE CHECK
WATER SOURCE HEAT PUMPS

INSTALLER PLEASE FILL OUT AND
RETAIN WITH UNIT

DATE OF INSTALLATION _____ MODEL NO(S) _____ SERIAL NO(S) _____

ITEM	COOLING	HEATING	JOB NUMBER
1. HEAD PRESSURE			NAME OF INSTALLER
2. SUCTION PRESSURE			NAME OF OWNER
3. WATER TEMP.(IN)			ADDRESS
4. WATER TEMP. (OUT)			CITY STATE
5. WATER PRESSURE (IN)			
6. WATER PRESSURE (OUT)			FIELD COMMENTS:
7. WATER FLOW (GPM)			
8. AMPERES (BLOWER)			
9. AMPERES (COMPRESSOR)			
10. LINE VOLTAGE (COMPRESSOR RUNNING)			
11. AIR TEMP.(IN) D.B.			
W.B.			
12. AIR TEMP.(OUT) D.B.			
W.B.			
13. DESUPERHEATER H ₂ O TEMP. (IN)			
14. DESUPERHEATER H ₂ O TEMP. (OUT)			

*This PERFORMANCE CHECK SHEET should be
filled out by installer and retained with unit.*

PARTS LIST
PACKAGED HORIZONTAL
WATER SOURCE HEAT PUMPS

PART NO.	DESCRIPTION	HWP30	HWPD30	HWP36	HWPD36
900-050	Blower Assembly Complete	x	x	x	x
5152-047	Blower Wheel DD10-6	x	x	x	x
8552-007	Capacitor -Comp. 20/15 - 370V	x	x		
8552-035	Capacitor-Comp. 40/370V			x	x
8552-025	Capacitor - Blower 7.5/440V	x	x	x	x
8000-071	Compressor AB225HT	x	x		
8000-052	Compressor CRG1-0250			x	x
5052-001	Condenser Coil	x	x		
5052-001	Condenser Coil			x	x
8401-007	Contactora - Compressor	x	x	x	x
5052-004	Desuperheater Coil		x		x
5060-034	Evaporator Coil	x	x	x	x
8406-016	High Pressure Switch	x	x	x	x
8406-015	Low Pressure Switch	x	x	x	x
8105-022	Motor - Blower 1/3 PSC	x	x	x	x
8200-003	Motor Mount	x	x	x	x
8201-008	Relay - Blower	x	x	x	x
8201-015	Relay - Emergency Heat	x	x	x	x
8201-034	Relay - Lockout	x	x	x	x
5650-009	Reversing Valve			x	x
5650-008	Reversing Valve	x	x	x	x
5650-005	Reversing Valve	x	x		
5650-011	Solenoid Valve		x		x
5210-010	Strainer	(2)	(2)	(2)	(2)
8607-011	Terminal Block	x	x	x	x
5651-041	Thermostat Expansion Valve	x	x	x	x
8300-001	Water Pump		x		x
8408-007	Water Pump Thermostat		x		x
8406-020	Toggle Switch		x		x
8407-015	Transformer 55VA	x	x	x	x
OPTIONAL ITEMS:					
8604-067	Duct Heater 4.8 Kw	x	x	x	x
8604-068	Duct Heater 9.6 Kw	x	x	x	x
8604-069	Duct Heater 15.0 Kw	x	x	x	x
8604-070	Duct Heater 19.2 Kw	x	x	x	x
8603-006	Solenoid Valve	x	x	x	x
8603-010	Constant Flow Valve 4 GPM	x	x		
8603-011	Contant Flow Valve 5 GPM			x	x

Minimum Net Billing \$15.00. Supersedes all previous lists.
Subject to change without notice. F.O.B. Bryan, Ohio.



PERFORMANCE CHECK
WATER SOURCE HEAT PUMPS

INSTALLER
PLEASE FILL OUT
AND RETURN TO
BARD MANUFACTURING CO.

*Please fill out as much of the below information as you can.
This information is needed by our Service Department to better
assist you in the event of possible future service needs.*

DATE OF INSTALLATION _____ MODEL NO(S) _____ SERIAL NO(S) _____

ITEM	COOLING	HEATING	JOB NUMBER
1. HEAD PRESSURE			NAME OF INSTALLER
2. SUCTION PRESSURE			NAME OF OWNER
3. WATER TEMP.(IN)			ADDRESS
4. WATER TEMP. (OUT)			CITY STATE
5. WATER PRESSURE (IN)			
6. WATER PRESSURE (OUT)			FIELD COMMENTS:
7. WATER FLOW (GPM)			
8. AMPERES (BLOWER)			
9. AMPERES (COMPRESSOR)			
10. LINE VOLTAGE (COMPRESSOR RUNNING)			
11. AIR TEMP.(IN) D.B.			
W.B.			
12. AIR TEMP.(OUT) D.B.			
W.B.			
13. DESUPERHEATER H ₂ O TEMP. (IN)			
14. DESUPERHEATER H ₂ O TEMP. (OUT)			

*This PERFORMANCE CHECK SHEET should be
filled out by installer and returned to:*

Bard Manufacturing Company
P.O. Box 607
Bryan, Ohio 43506

State

Fold here

PLACE
STAMP
HERE

BARD MANUFACTURING COMPANY
P. O. Box 607
BRYAN, OHIO 43506

Fold here