

INSTALLATION INSTRUCTIONS

MODELS

EH3MA-1-5A
EH3MA-1-8A
EH3MA-1-10A
EH3MA-1-15A
EH3MA-1-20A

OPTIONAL ELECTRIC HEAT PACKAGES

FOR USE WITH MODELS

MU30A, MU36C, MU42D
MH30A, MH36A, MH42A

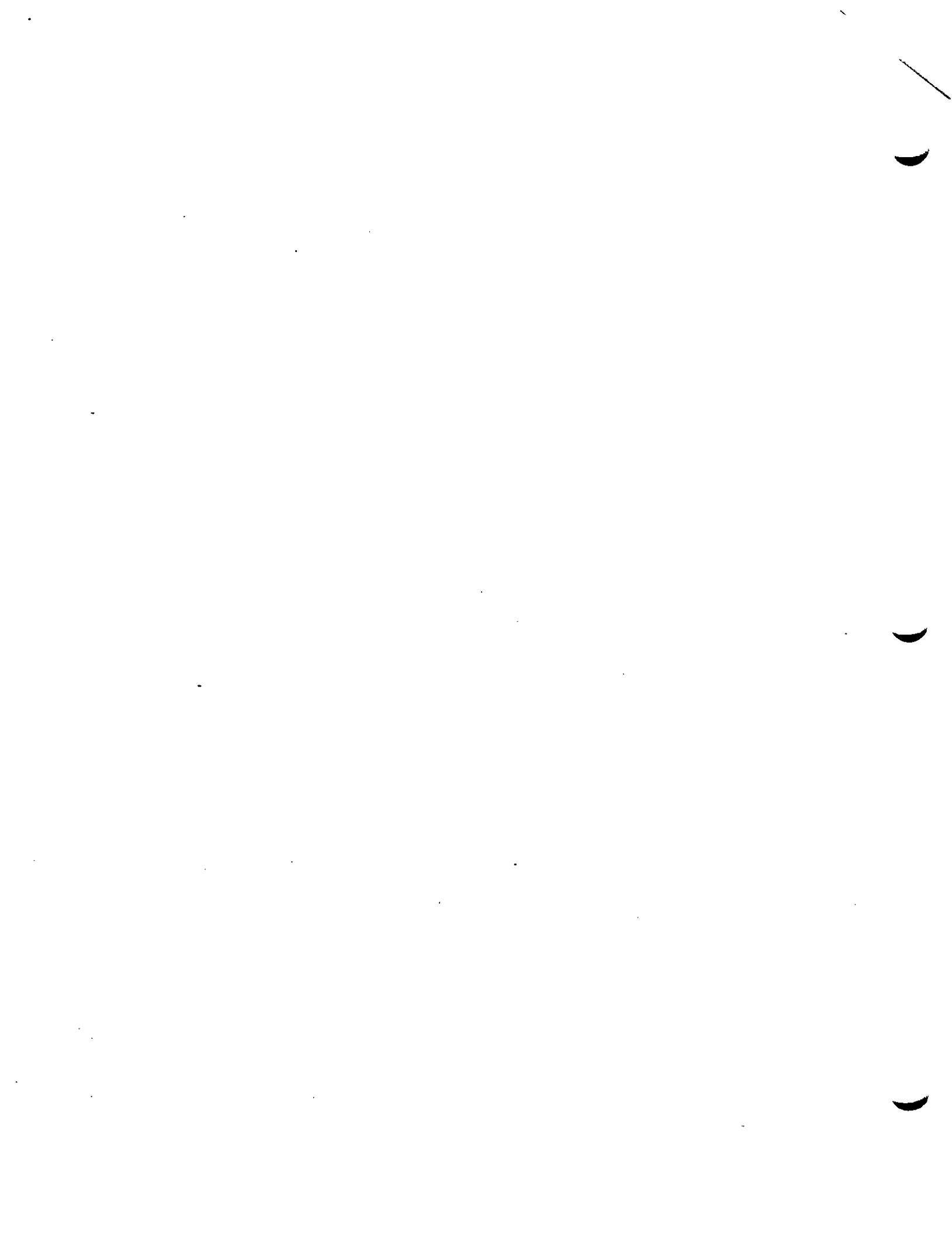

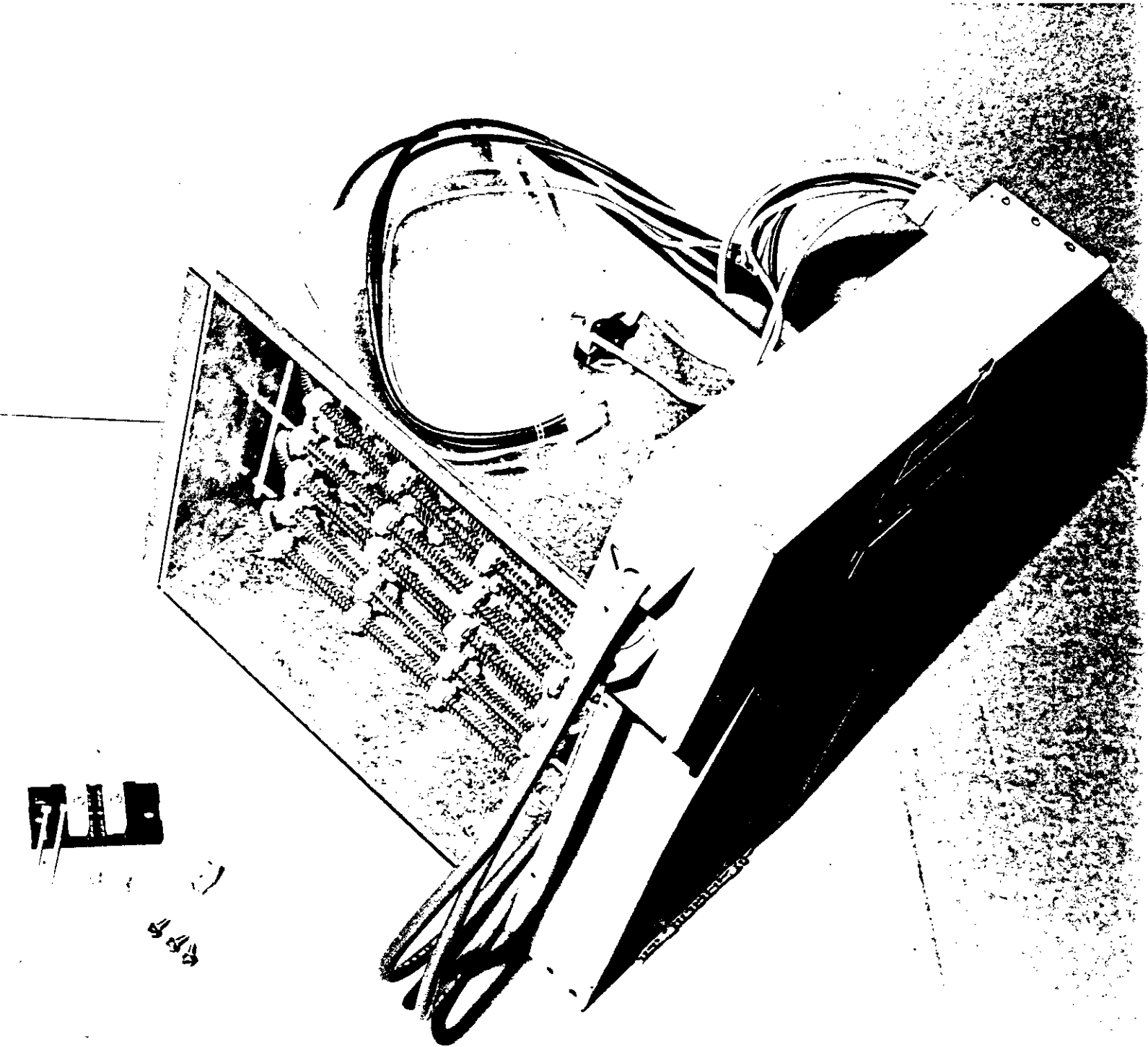

Figure 1

IMPORTANT

The equipment covered in this manual is to be installed by trained, experienced service and installation technicians.

SHIPPING DAMAGE

Upon receipt of equipment, the carton should be checked for external signs of shipping damage. If damage is found, the receiving party must contact the last carrier immediately, preferably in writing, requesting inspection by the carrier's agent.

UNPACKING THE HEAT PACKAGE

Remove the heat package from the shipping carton. The heat package must consist of the following: (See Fig. 1)

1. Basic heater enclosure with controls and installation instructions.
2. Plastic bag containing (1) 230V terminal block, (1) grounding lug, (3) #10-16 x 1/2" screws, (2) #10-12 x 3/4" screws and (2) wire ties.

INSTALLATION

Disconnect all power supplies to the air conditioner or heat pump. Remove the blower service door located to the right of the unit control panel. Remove the two screws used to secure the blower housing to the slide mount (Figure 2). Remove the blower assembly from the slide mount taking care to protect all blower motor leads from damage.

Install the basic heater enclosure into the slide mount previously used for mounting the blower. Secure the heater enclosure to the slide mount with the two screws that were removed earlier from the blower housing.

Slide the blower housing into the heater enclosure slide mount located on the left side of the enclosure. Secure the blower housing to the heater enclosure with two screws (shipped in plastic bag).

IMPORTANT

The optional heat packages in conjunction with models MH30A, MH36A or MH42A are internally wired to allow a maximum of 10Kw of electric heat to be energized during heat pump operation. Any installed Kw over 10Kw will operate only during the emergency heat mode.

A maximum of 20Kw may operate in the heating mode for models MU30A, MU36C and MU42D.

WIRING CONNECTIONS

Connect the wires exiting the rear of the heater package into the unit circuit by plugging in the plastic snap lock fitting into the mating fitting located on the insulated partition between the control panel and the blower area.

IMPORTANT: A separate power supply must be provided for use with any optional heater package. DO NOT attempt to connect a heater package with a basic unit to a single power supply.

Remove the unit control panel cover and the inner 4-1/4" x 7-3/4" cover. By removing this cover an isolated area is exposed. Install the 230 volt terminal block and the grounding lug using the enclosed screws into prepunched holes supplied.

Route the two 29" long wires from the heater package through the provided hole in the insulated partition to the newly installed 230 volt terminal block.

Connect the wires to the fuse or terminal block in the enclosure.

Inspect all wiring for damage and secure any loose wiring with the enclosed wire ties. See Figure 3 for completed assembly. Replace the terminal block cover, control box cover and blower service door.

Energize both power supplies and check for proper system operation.

| PARTS LIST | | | | | | |
|---------------------------------|----------------------|------------|------------|-------------|-------------|-------------|
| OPTIONAL ELECTRIC HEAT PACKAGES | | | | | | |
| PART NO. | DESCRIPTION | EH3MA-1-5A | EH3MA-1-8A | EH3MA-1-10A | EH3MA-1-15A | EH3MA-1-20A |
| 8401-006 | Contactors 2P20 | (1) | (1) | (1) | (2) | (2) |
| 8614-006 | Fuse 0T 30 | | | | (2) | |
| 8614-007 | Fuse 0T 60 | | | | (2) | (4) |
| 8614-017 | Fuse Block | | | | x | |
| 8614-018 | Fuse Block | | | | | x |
| 8604-023 | Heat Strip 5Kw | x | | | | |
| 8604-024 | Heat Strip 10Kw | | | x | | (2) |
| 8604-025 | Heat Strip 15Kw | | | | x | |
| 8402-011 | Limit Switch | x | x | x | x | x |
| 8201-008 | Heating Blower Relay | x | x | x | x | x |
| 8607-001 | Terminal Block | (2) | (2) | (2) | (1) | (1) |
| 8402-030 | Thermal Cutoff | (1) | (2) | (2) | (3) | (4) |
| 8604-026 | Heat Strip 8Kw | | x | | | |

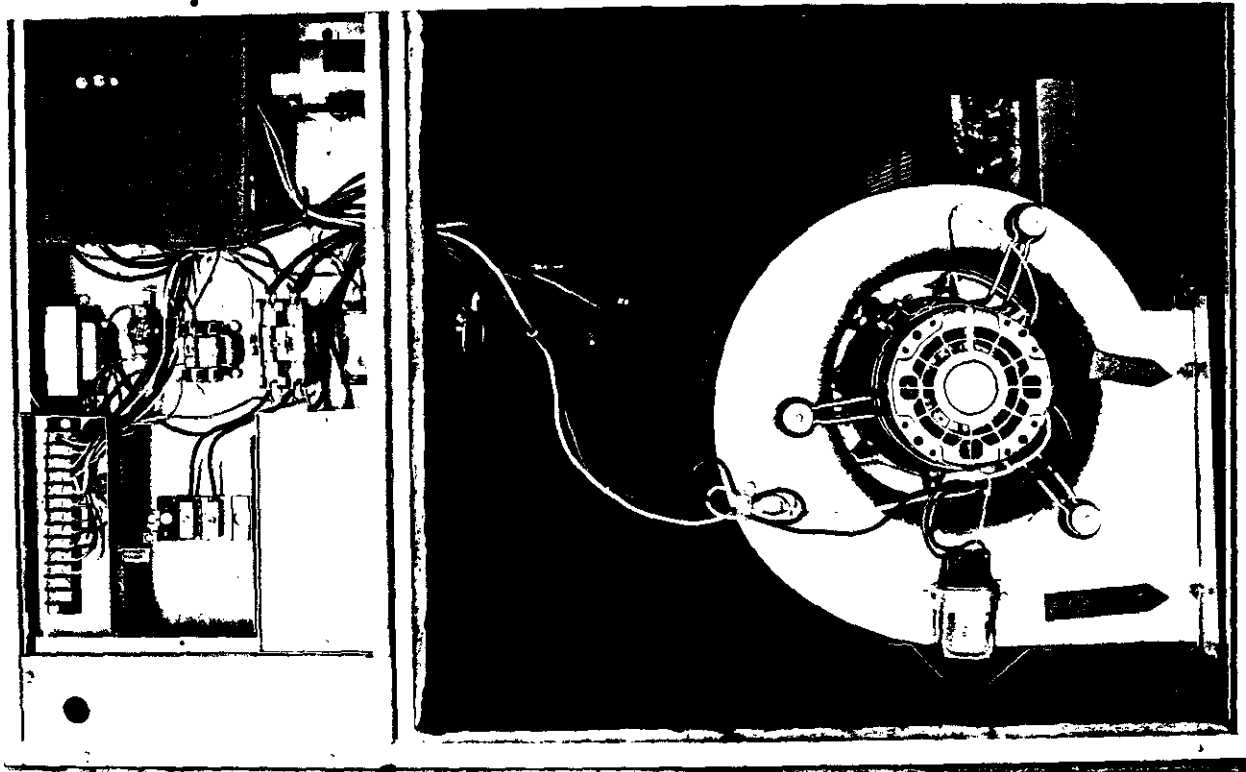

Figure 2

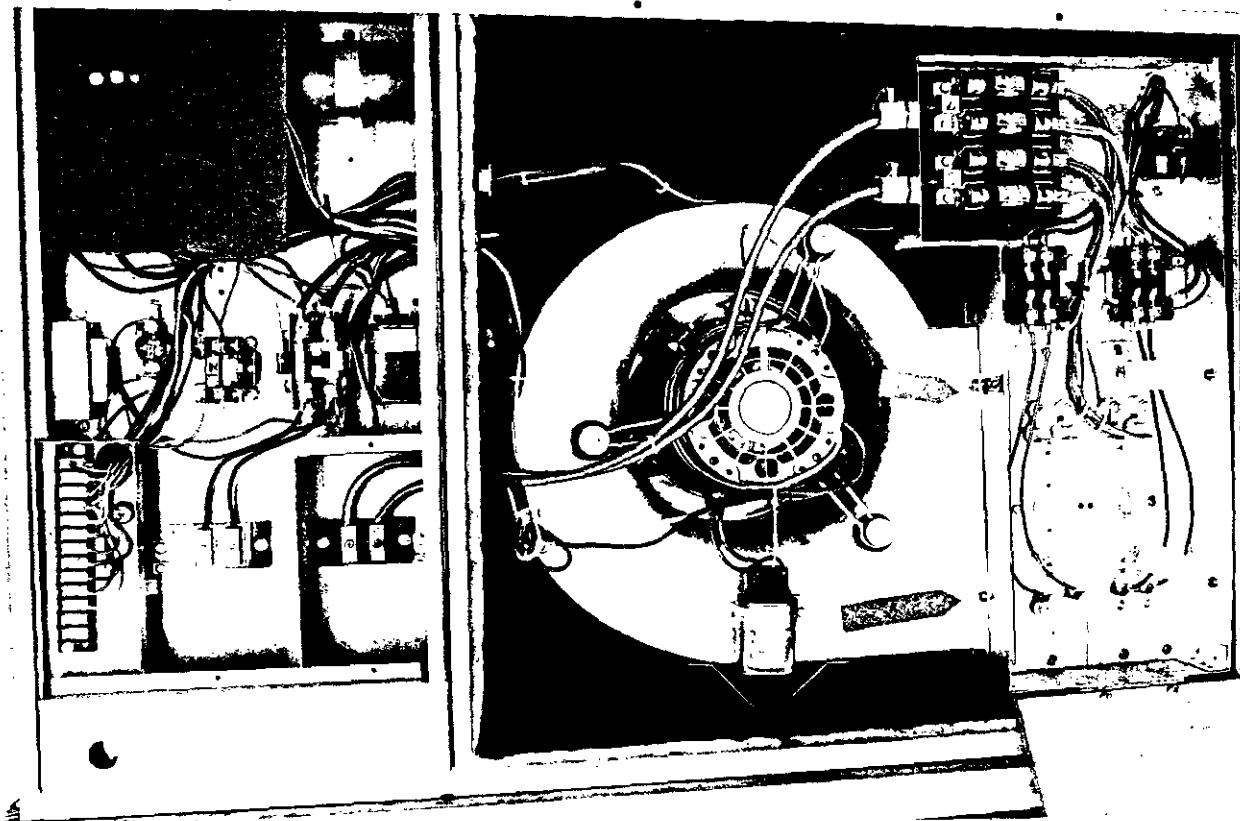
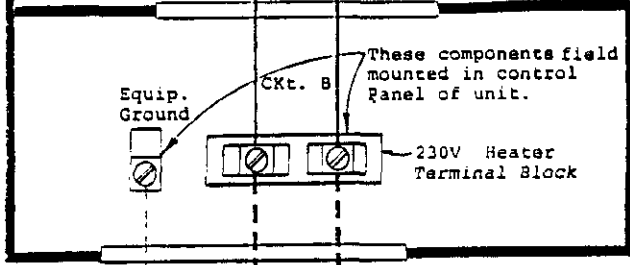
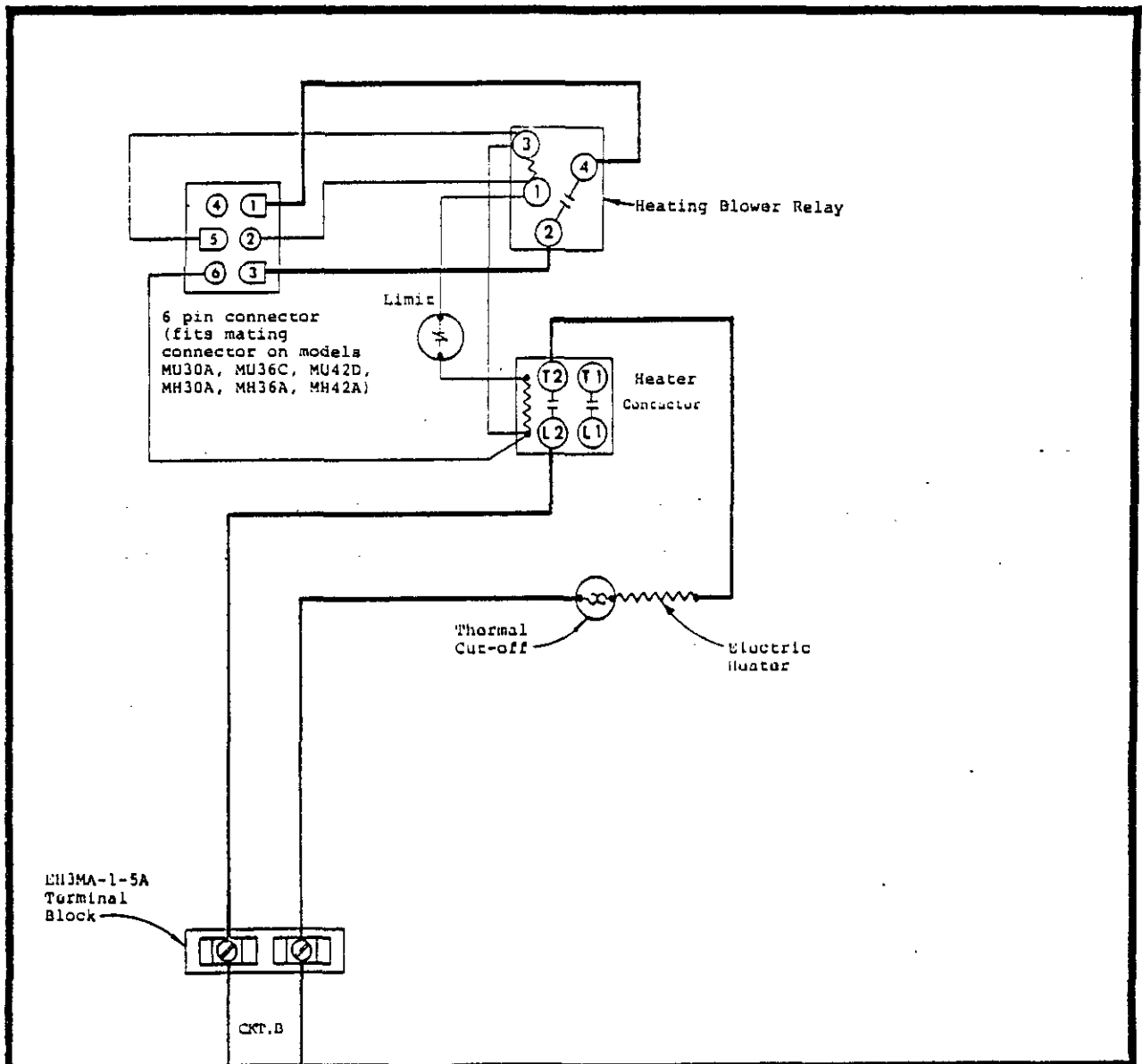

Figure 3



- ⚠ The EH3MA-1-5A heater package consists of the following:
- (1) Basic heater package.
 - (1) Terminal Block (Cat. No. EB or 11993).
 - (1) Listed Ground Terminal 6-12 AL, 6-14 CU.

Refer to the heat package instructions for proper installation.

USE COPPER OR ALUMINUM WIRE

⚠ EH3MA-1-5A HEATER PACKAGE

| | FACTORY WIRING | FIELD WIRING |
|--------------|----------------|--------------|
| Low Voltage | ————— | ----- |
| High Voltage | ————— | ----- |

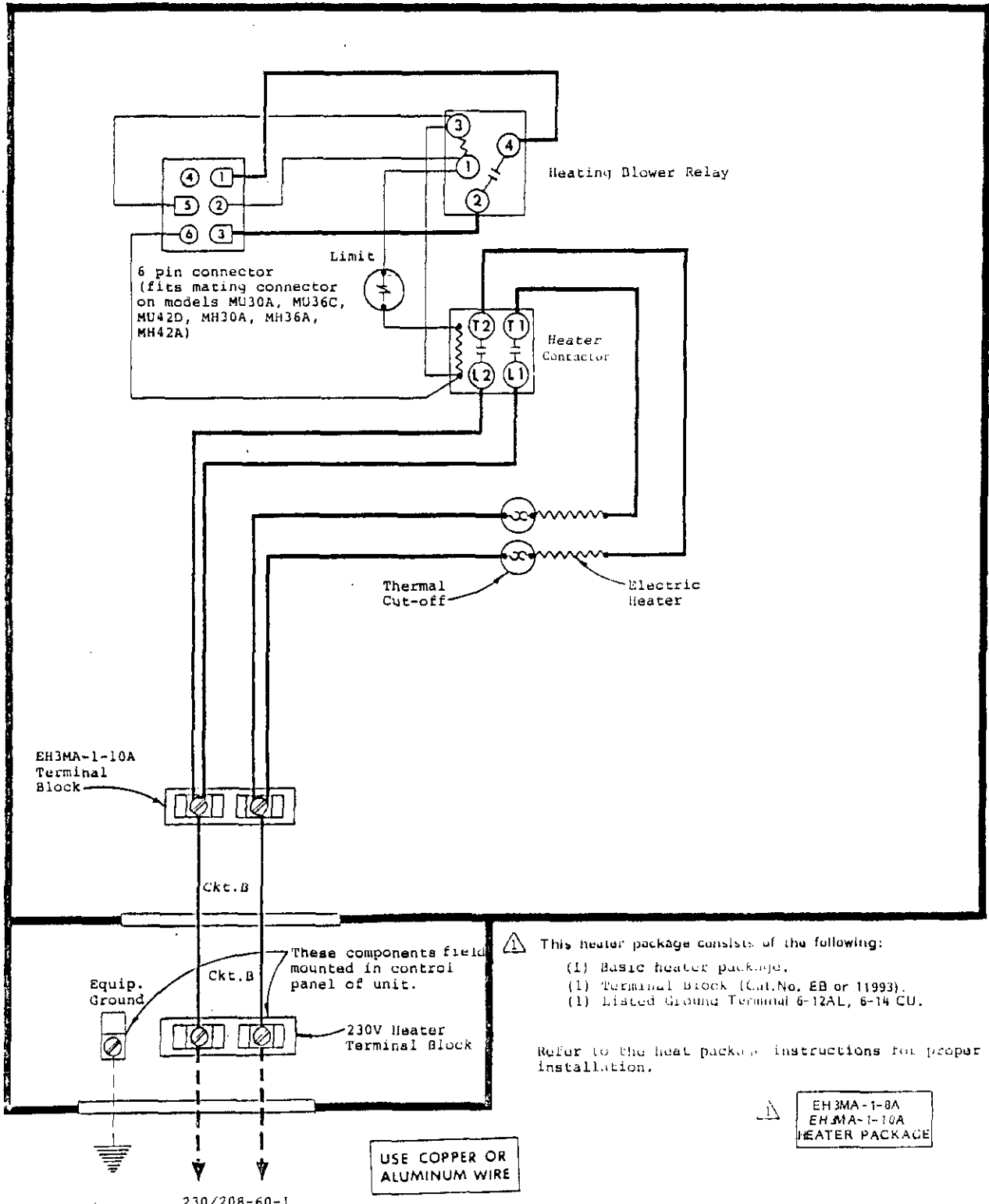

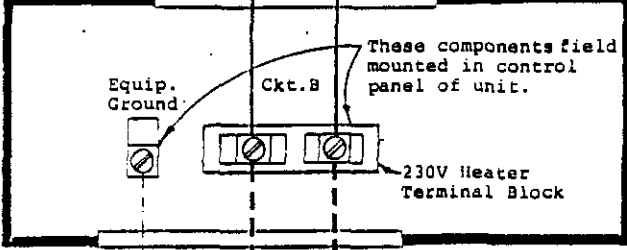
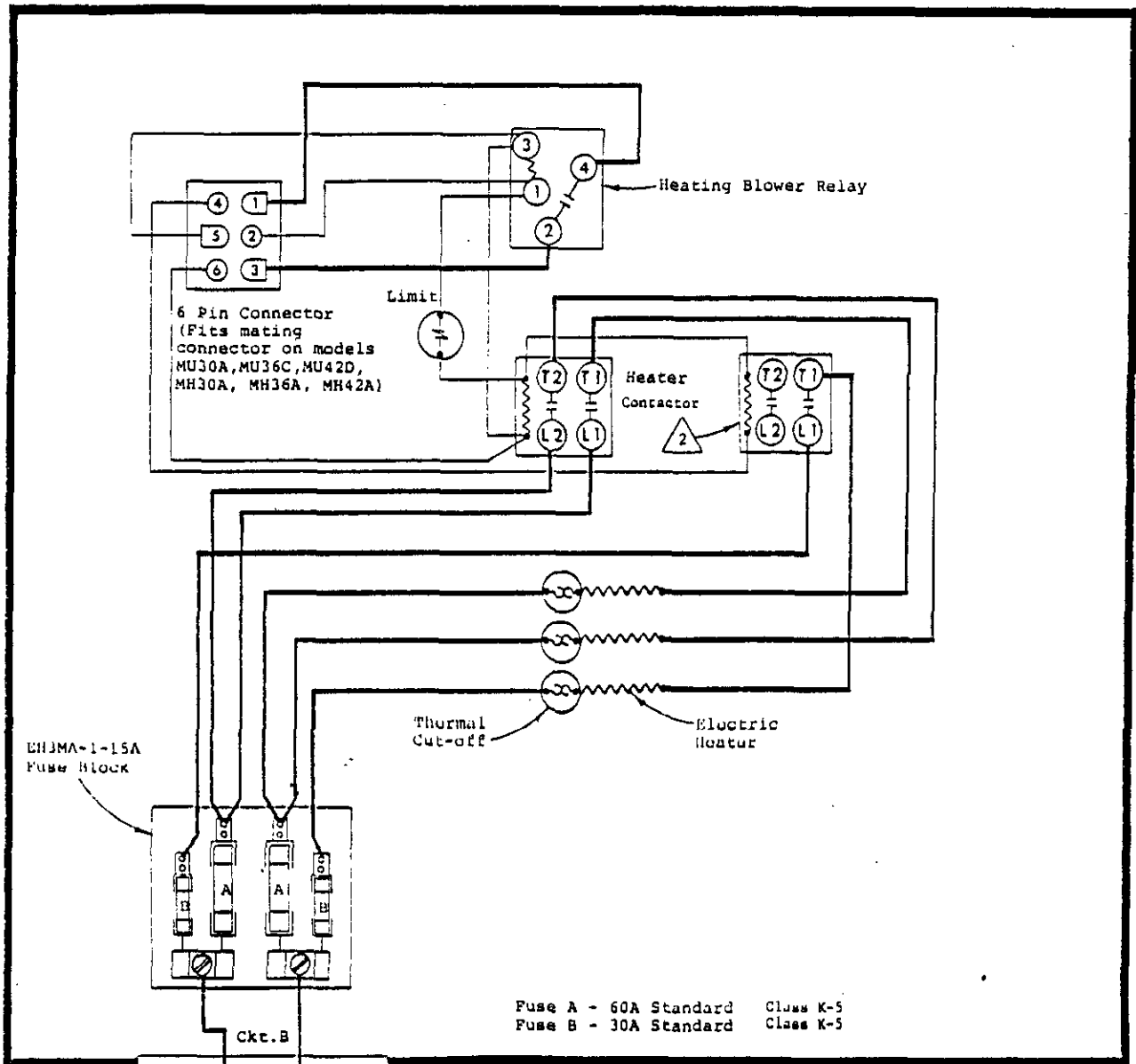

- ⚠ The EH3MA-1-15A heater package consists of the following:
- (1) Basic heater package.
 - (1) Terminal Block (Cat.No. EB or 11993).
 - (1) Listed Ground Terminal 6-12 AL, 6-14 CU.

Refer to the heat package instructions for proper installation.

⚠ 2nd heat contactor operates only during emergency heat or compressor cut-off.

USE COPPER OR ALUMINUM WIRE

⚠ EH3MA-1-15A HEATER PACKAGE

| FACTORY WIRING | FIELD WIRING |
|----------------|--------------|
| Low Voltage | ----- |
| High Voltage | ----- |

230/208-60-1

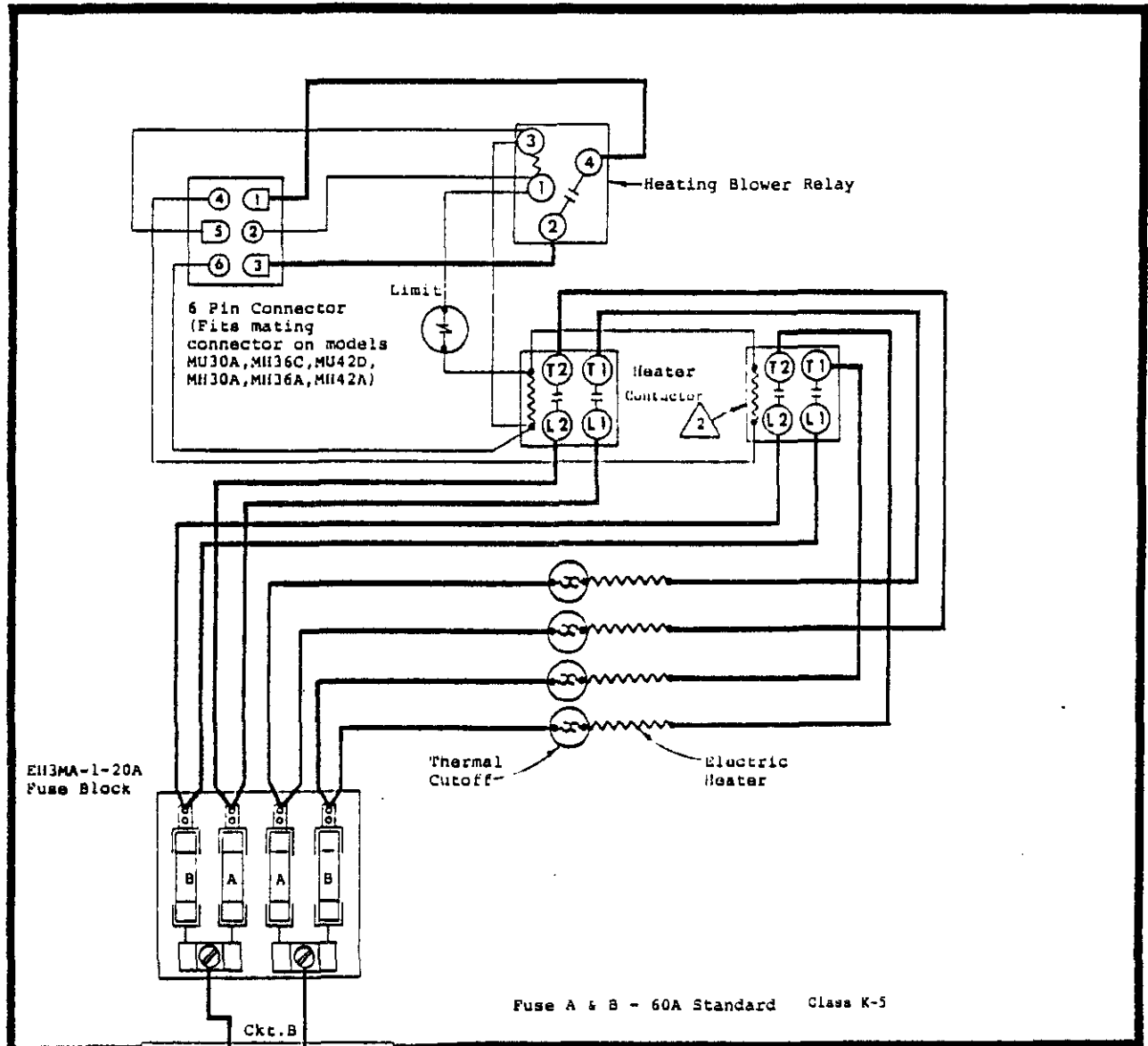

- ⚠ The EH3MA-1-20A heater package consists of the following:
- (1) Basic heater package.
 - (1) Terminal Block (Cat. No. EH or 11993).
 - (1) Listed Ground Terminal 6-12 AL, 6-14 CU.

⚠ Refer to the heat package instructions for proper installation. 2nd heat contactor operates only during emergency heat or compressor cut-off.



EH3MA-1-20A HEATER PACKAGE

USE COPPER OR ALUMINUM WIRE

| FACTORY WIRING | FIELD WIRING |
|------------------|------------------------|
| Low Voltage ——— | Low Voltage - - - - - |
| High Voltage ——— | High Voltage - - - - - |