



HEATING & AIR CONDITIONING

INSTALLATION INSTRUCTIONS

MODELS

EH3MA-1-5A

EH3MA-1-10A

EH3MA-1-15A

EH3MA-1-20A

OPTIONAL ELECTRIC HEAT PACKAGES

FOR USE WITH MODELS

MH30A, MH36A, MH42A



Home

A DIVISION OF LEAR SIEGLER, INC.
900 BROOKS AVENUE HOLLAND, MICHIGAN 49423 (616) 394-4200



B

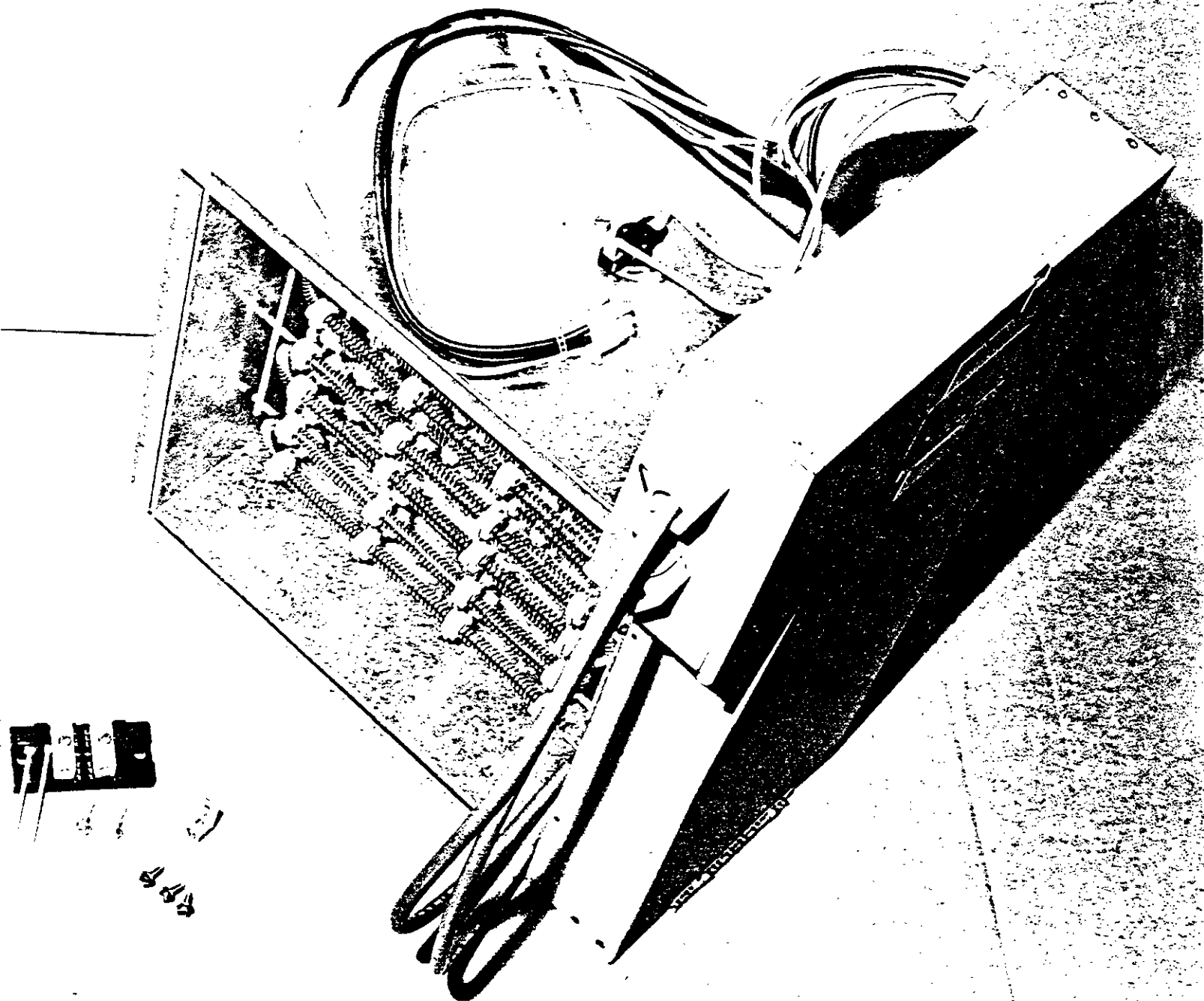

Figure 1

IMPORTANT

The equipment covered in this manual is to be installed by trained, experienced service and installation technicians.

SHIPPING DAMAGE

Upon receipt of equipment, the carton should be checked for external signs of shipping damage. If damage is found, the receiving party must contact the last carrier immediately, preferably in writing, requesting inspection by the carrier's agent.

UNPACKING THE HEAT PACKAGE

Remove the heat package from the shipping carton. The heat package must consist of the following: (See Fig. 1)

1. Basic heater enclosure with controls and installation instructions.
2. Plastic bag containing (1) 230V terminal block, (1) grounding lug, (3) #10-16 x 1/2" screws, (2) #10-12 x 3/4" screws and (2) wire ties.

INSTALLATION

Disconnect all power supplies to the air conditioner or heat pump. Remove the blower service door located to the right of the unit control panel. Remove the two screws used to secure the blower housing to the slide mount (Figure 2). Remove the blower assembly from the slide mount taking care to protect all blower motor leads from damage.

Install the basic heater enclosure into the slide mount previously used for mounting the blower. Secure the heater enclosure to the slide mount with the two screws that were removed earlier from the blower housing.

Slide the blower housing into the heater enclosure slide mount located on the left side of the enclosure. Secure the blower housing to the heater enclosure with two screws (shipped in plastic bag).

IMPORTANT

The optional heat packages in conjunction with models MH30A, MH36A or MH42A are internally wired to allow a maximum of 10Kw of electric heat to be energized during heat pump operation. Any installed Kw over 10Kw will operate only during the emergency heat mode.

If this unit is operated in cooling below a 65° outdoor ambient temperature, the installation of low ambient controls (LAC-1 and 8201-008 relay) to unit is required.

WIRING CONNECTIONS

Connect the wires exiting the rear of the heater package into the unit circuit by plugging in the plastic snap lock fitting into the mating fitting located on the insulated partition between the control panel and the blower area.

IMPORTANT: A separate power supply must be provided for use with any optional heater package. DO NOT attempt to connect a heater package with a basic unit to a single power supply.

Remove the unit control panel cover and the inner 4-1/4" x 7-3/4" cover. By removing this cover an isolated area is exposed. Install the 230 volt terminal block and the grounding lug using the enclosed screws into prepunched holes supplied.

Route the two 29" long wires from the heater package through the provided hole in the insulated partition to the newly installed 230 volt terminal block.

Connect the wires to the fuse or terminal block in the enclosure.

Inspect all wiring for damage and secure any loose wiring with the enclosed wire ties. See Figure 3 for completed assembly. Replace the terminal block cover, control box cover and blower service door.

Energize both power supplies and check for proper system operation.

PARTS LIST						
OPTIONAL ELECTRIC HEAT PACKAGES						
PART NO.	DESCRIPTION	EH3MA-A05	EH3MA-A08	EH3MA-A10	EH3MA-A15	EH3MA-A20
8401-006	Contactor 2P20	(1)	(1)	(1)	(2)	(2)
8614-006	Fuse 0T30				(2)	
8614-007	Fuse 0T60				(2)	(4)
8614-017	Fuse Block				x	
8614-018	Fuse Block					x
8604-023	Heat Strip 5Kw	x				
8604-024	Heat Strip 10Kw			x		(2)
8604-025	Heat Strip 15Kw				x	
8402-011	Limit Switch	x	x	x	x	x
8201-008	Heating Blower Relay	x	x	x	x	x
8607-013	Terminal Block	x	x	x		
8402-030	Thermal Cutoff	(1)	(2)	(2)	(3)	(4)
8604-026	Heat Strip 8Kw		x			
4060-110	Wiring Diagram	x				
4060-120	Wiring Diagram		x	x		
4060-130	Wiring Diagram				x	
4060-140	Wiring Diagram					x

B

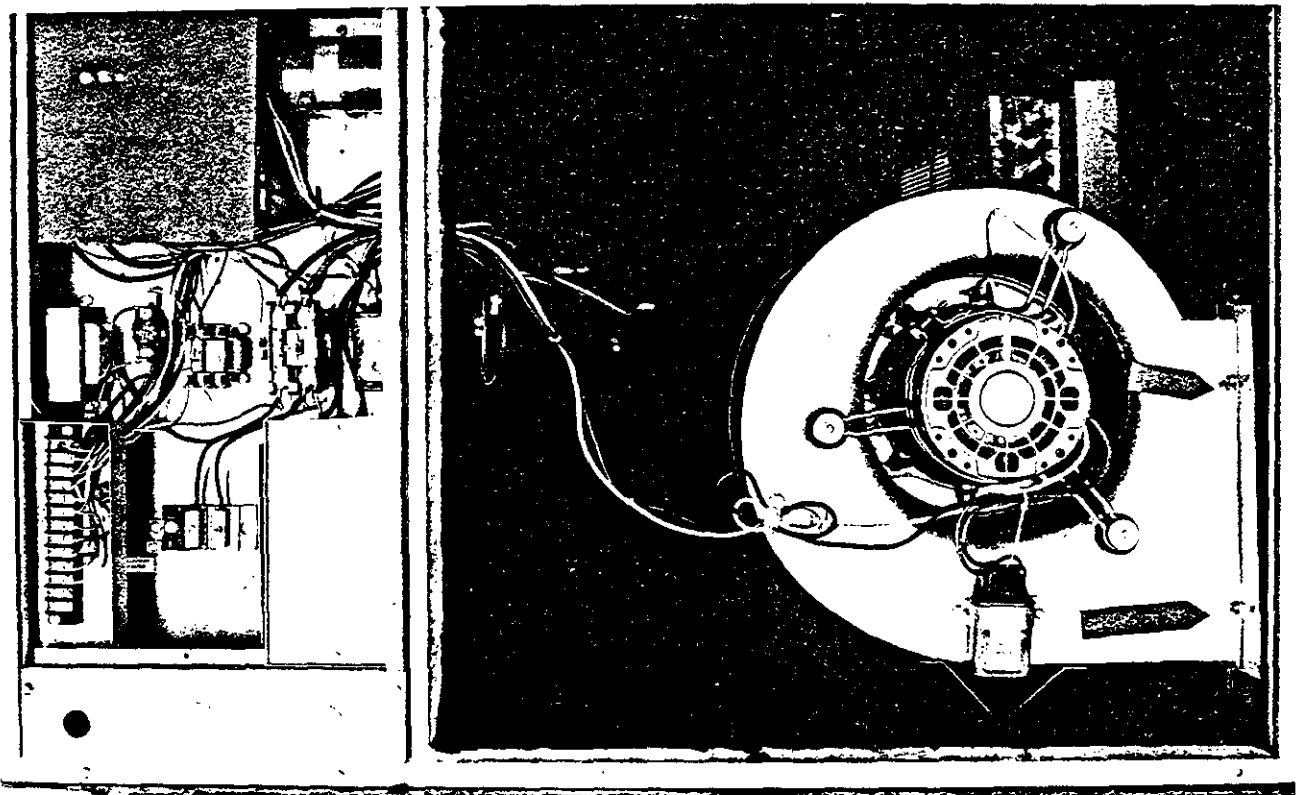

Figure 2

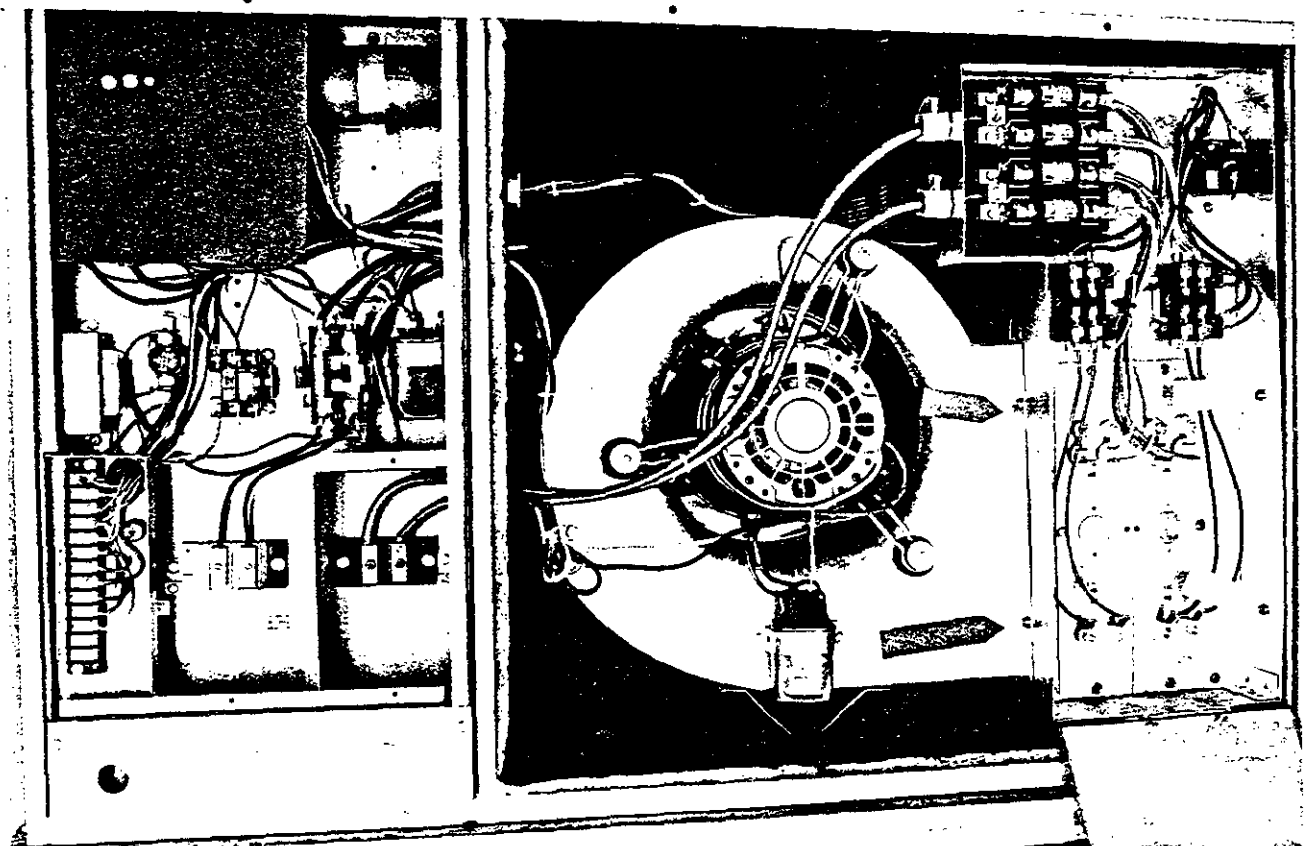
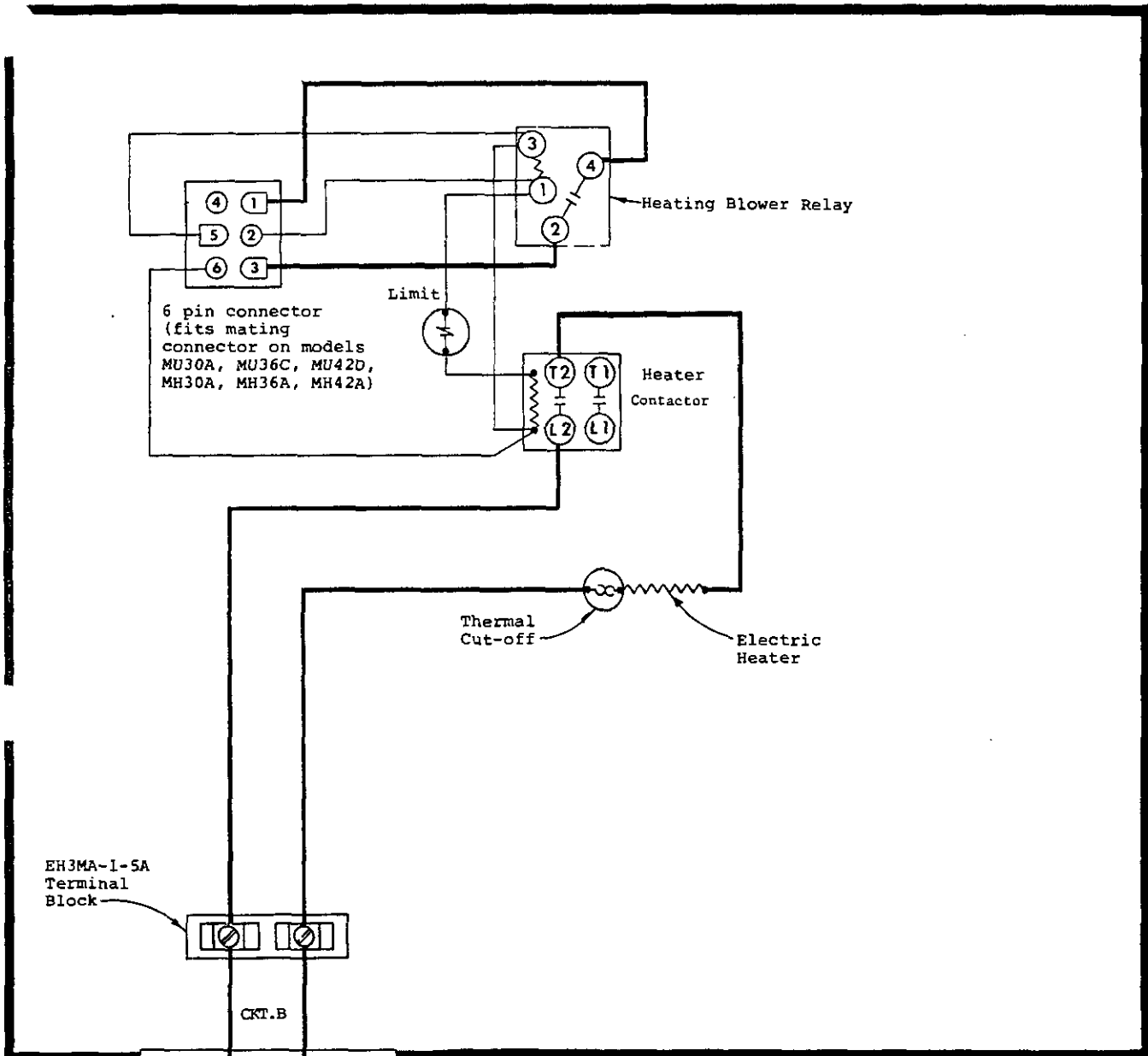

Figure 3



6 pin connector
(fits mating
connector on models
MU30A, MU36C, MU42D,
MH30A, MH36A, MH42A)

Heating Blower Relay

Heater
Contactor

Limit

Electric
Heater

Thermal
Cut-off

EH3MA-1-5A
Terminal
Block

CKT.B

Equip.
Ground

CKT. B

These components field
mounted in control
Panel of unit.

230V Heater
Terminal Block

230/208-60-1

- ⚠ The EH3MA-1-5A heater package consists of the following:
- (1) Basic heater package.
 - (1) Terminal Block (Cat. No. EB or 11993).
 - (1) Listed Ground Terminal 6-12 AL, 6-14 CU.

Refer to the heat package instructions for proper installation.

USE COPPER OR
ALUMINUM WIRE

⚠ EH3MA-1-5A
HEATER PACKAGE

	FACTORY WIRING	FIELD WIRING
Low Voltage	—————	- - - - -
High Voltage	—————	- - - - -

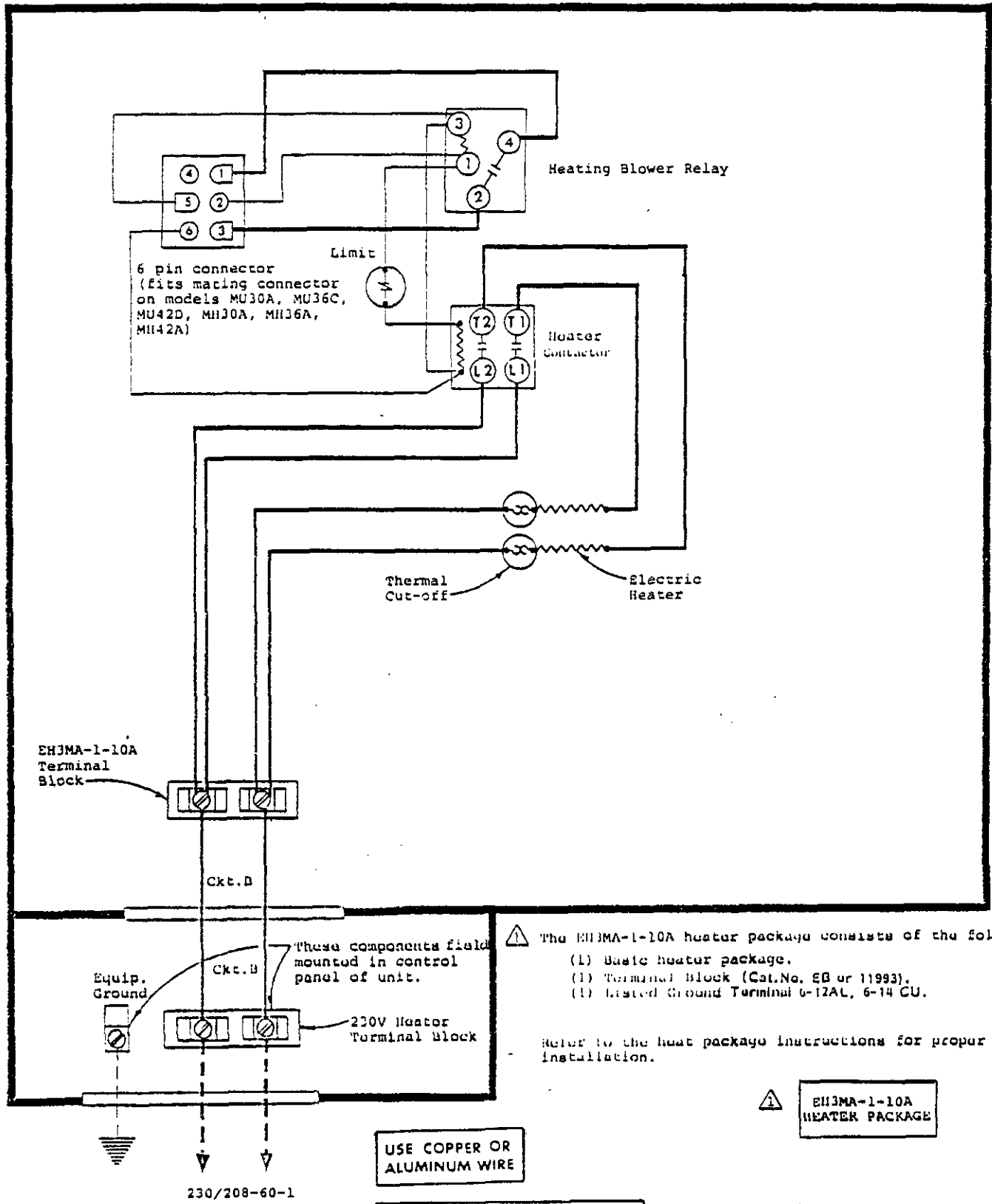

- ⚠ The EH3MA-1-10A heater package consists of the following:
- (1) Basic heater package.
 - (1) Terminal Block (Cat.No. EB or 11993).
 - (1) Listed Ground Terminal 6-12AL, 6-14 CU.

Refer to the heat package instructions for proper installation.

⚠ EH3MA-1-10A HEATER PACKAGE

	FACTORY WIRING	FIELD WIRING
Low Voltage	————	-----
High Voltage	————	-----

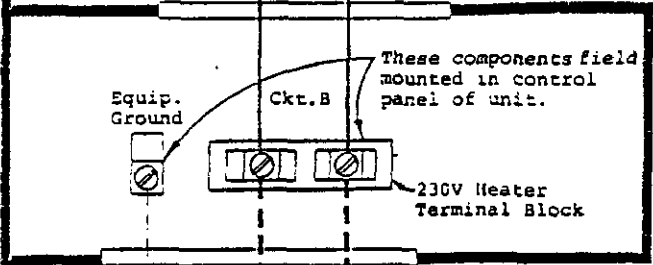
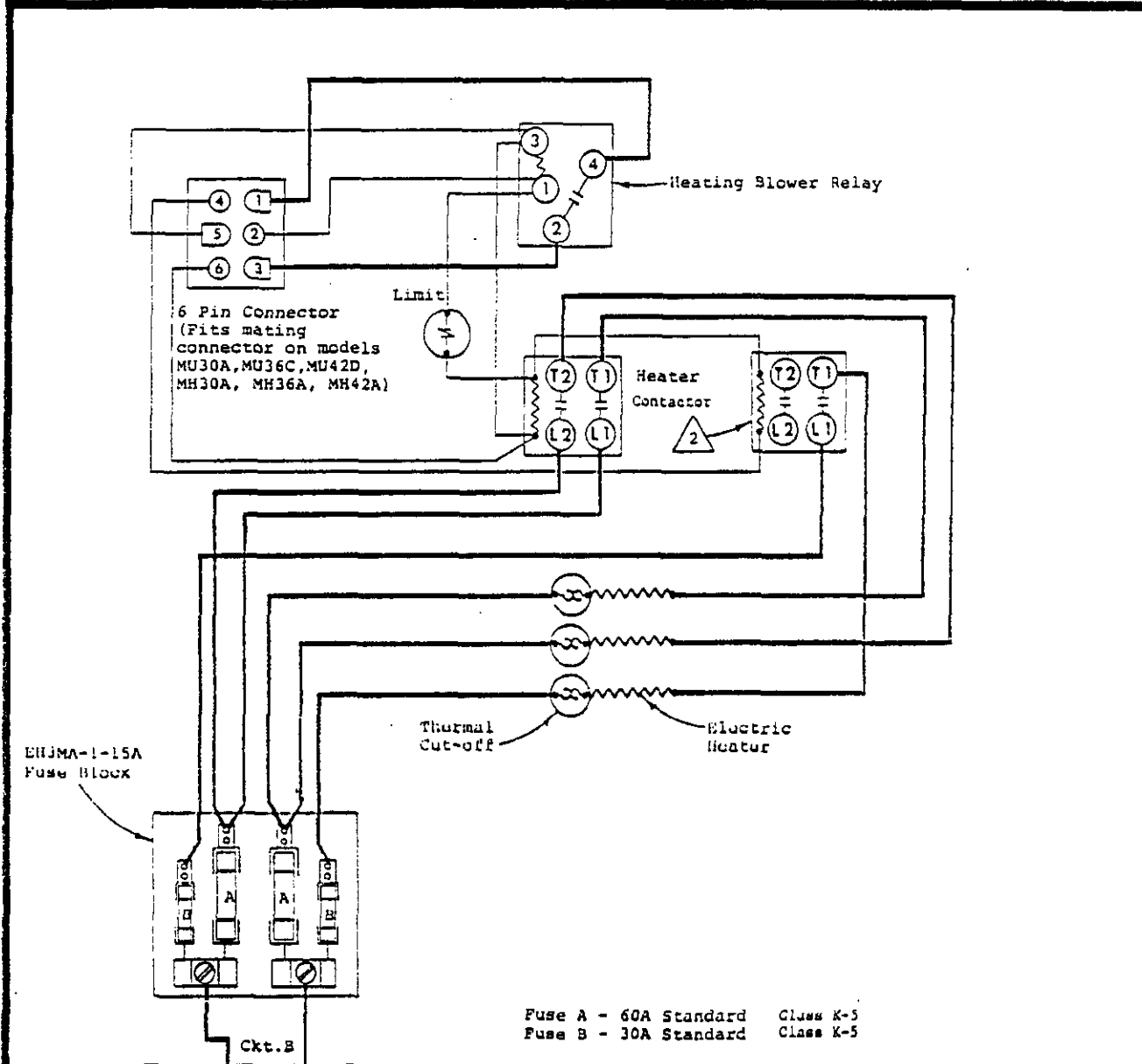

- ⚠ The EH3MA-1-15A heater package consists of the following:
- (1) Basic heater package.
 - (1) Terminal Block (Cat.No. EB or 11993).
 - (1) Listed Ground Terminal 6-12 AL, 6-14 CU.

Refer to the heat package instructions for proper installation

⚠ 2nd heat contactor operates only during emergency heat or compressor cut-off.

USE COPPER OR ALUMINUM WIRE

⚠ EH3MA-1-15A HEATER PACKAGE

FACTORY WIRING	FIELD WIRING
Low Voltage ———	-----
High Voltage ———	-----

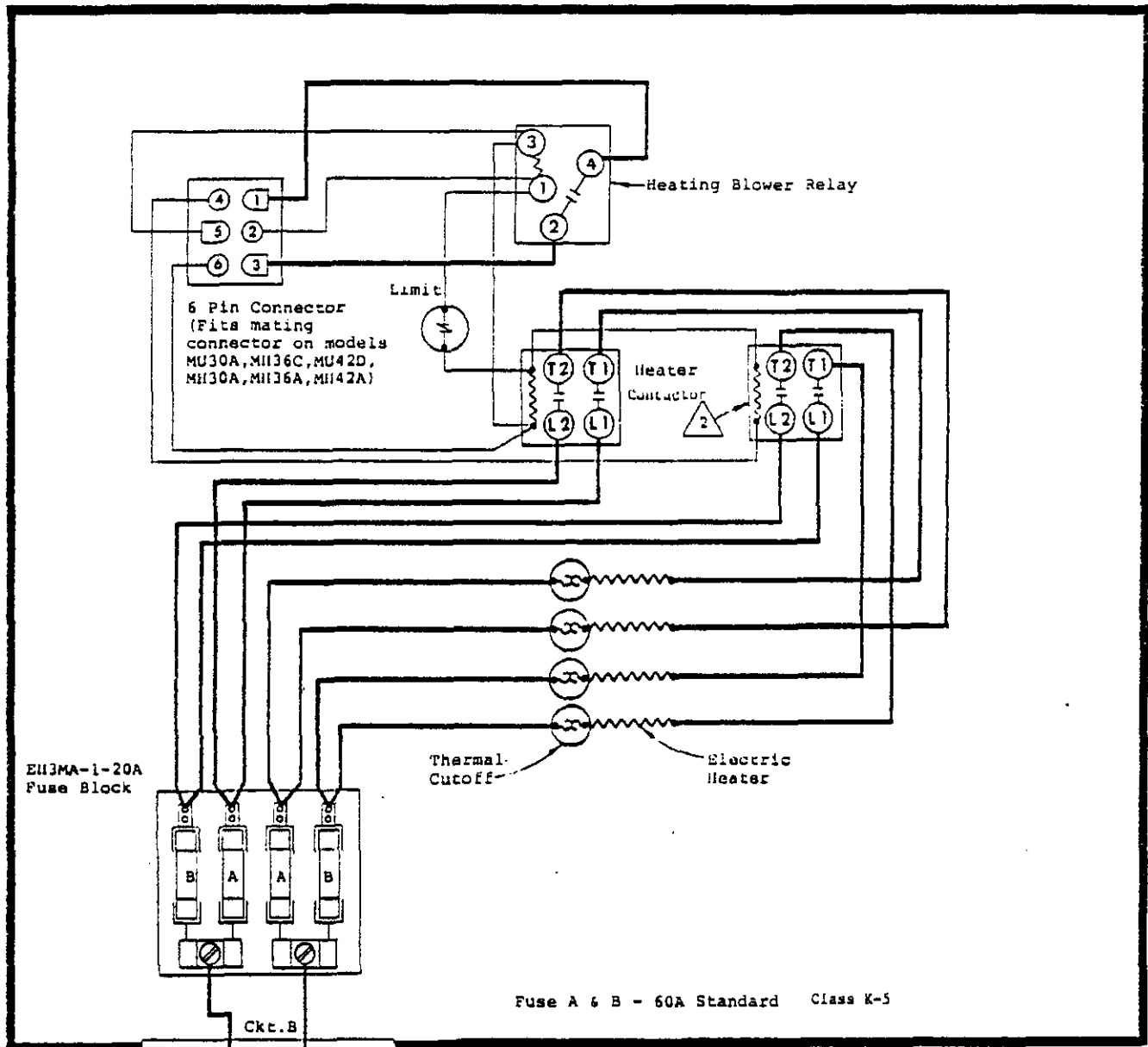

EH3MA-1-20A
Fuse Block

Fuse A & B - 60A Standard Class K-5

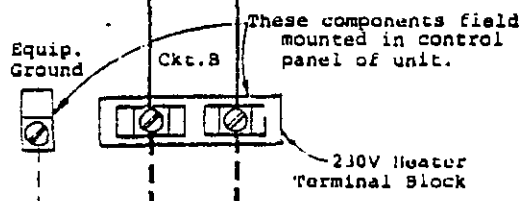

- ⚠ The EH3MA-1-20A heater package consists of the following:
- (1) Basic heater package.
 - (1) Terminal Block (Cat. No. EH or 11993).
 - (1) Listed Ground Terminal 6-12 AL, 6-14 CU.

⚠ Refer to the heat package instructions for proper installation. 2nd heat contactor operates only during emergency heat or compressor cut-off.

USE COPPER OR ALUMINUM WIRE

⚠ EH3MA-1-20A HEATER PACKAGE

FACTORY WIRING	FIELD WIRING
Low Voltage	-----
High Voltage	-----

230/208-60-1