

# INSTALLATION INSTRUCTIONS

## MODELS

EH3PA-1-5A  
EH3PA-1-10A  
EH3PA-1-15A  
EH3PA-3-9B  
EH3PA-3-12B  
EH3PA-3-15B  
EH3PA-3-9C  
EH3PA-3-12C  
EH3PA-3-15C

OPTIONAL ELECTRIC HEAT PACKAGES

FOR USE WITH 2.5 and 3 TON  
PACKAGED UNITS



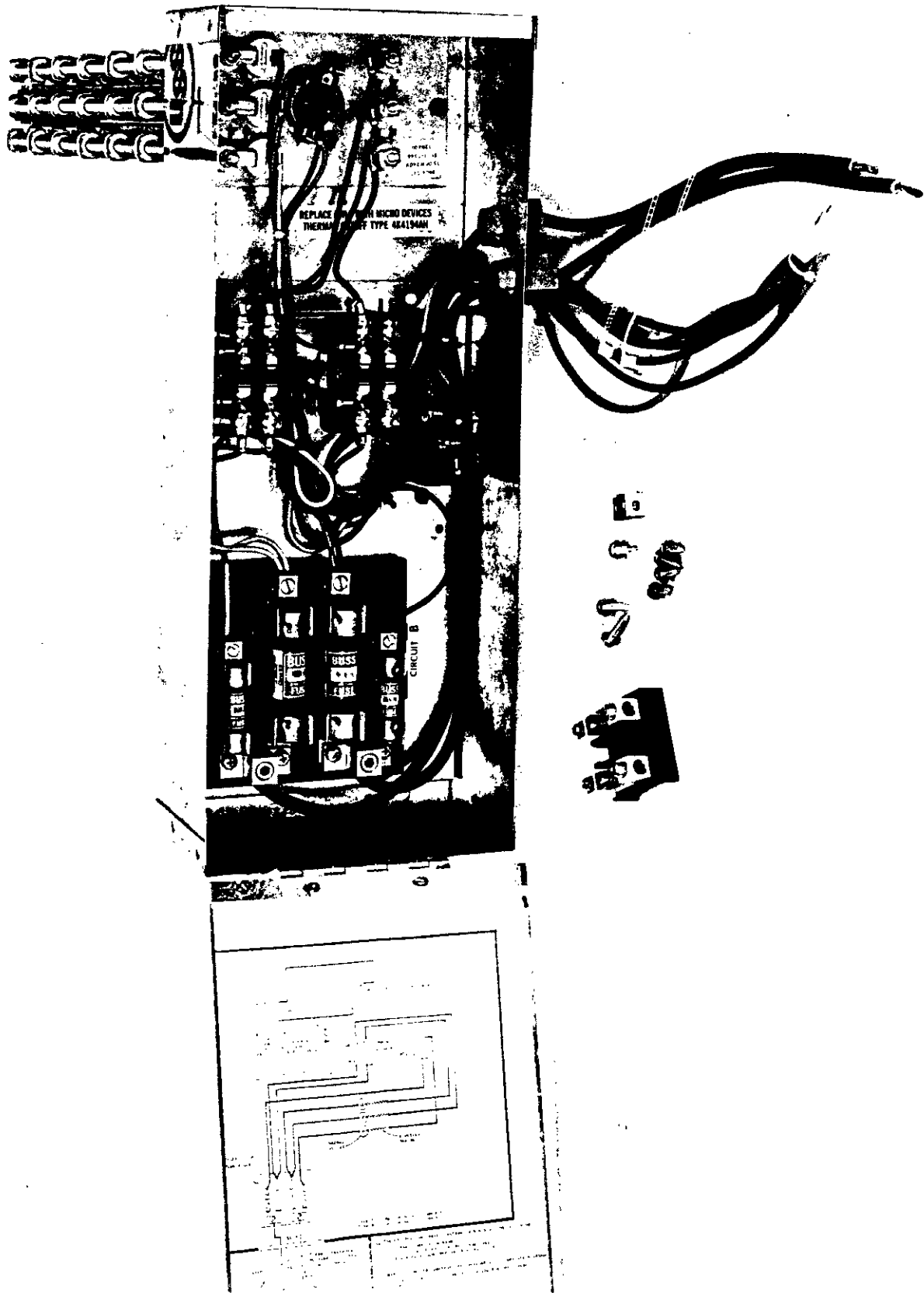

Figure 1

## IMPORTANT

The equipment covered in this manual is to be installed by trained, experienced service and installation technicians.

## SHIPPING DAMAGE

Upon receipt of equipment, the carton should be checked for external signs of shipping damage. If damage is found, the receiving party must contact the last carrier immediately, preferably in writing, requesting inspection by the carrier's agent.

## UNPACKING THE HEAT PACKAGE

Remove the heat package from the shipping carton. The heat package must consist of the following: (See Figure 1)

1. Basic heater enclosure with controls and installation instructions.
2. Plastic bag containing (1) 230V terminal block; (1) grounding lug; (4) #10-16 x 1/2" screws; (2) #8-16 x 1" screws; (1) #10-24 x 1/2" screw; and (1) wire tie.

## INSTALLATION

Disconnect all power supplies to the air conditioner or heat pump. Remove the control panel service door. Remove the four (4) #10-16 x 1/2" screws which secure the electric heat cover plate. Remove the electric heat cover plate from the blower partition and discard. Carefully insert heater package through the opening, provided in the blower partition. Guide the heater package into the opening being careful to align the locating pin(s) of the heater(s) in the dimpled holes provided in the rear of the blower partition. Line up the four (4) holes in the heater control panel with the four (4) prepunched holes in the blower partition and secure the heater package to the blower partition with the four (4) #10-16x1/2" screws provided.

## WIRING CONNECTIONS

Connect the wires exiting the bottom of the heater package into the unit circuit by plugging in the plastic snap lock fitting into the mating fitting located on the rear of the control panel.

**IMPORTANT:** A separate power supply must be provided for use with any optional heater package. DO NOT attempt to connect a heater package with a basic unit to a single power supply.



Figure 2

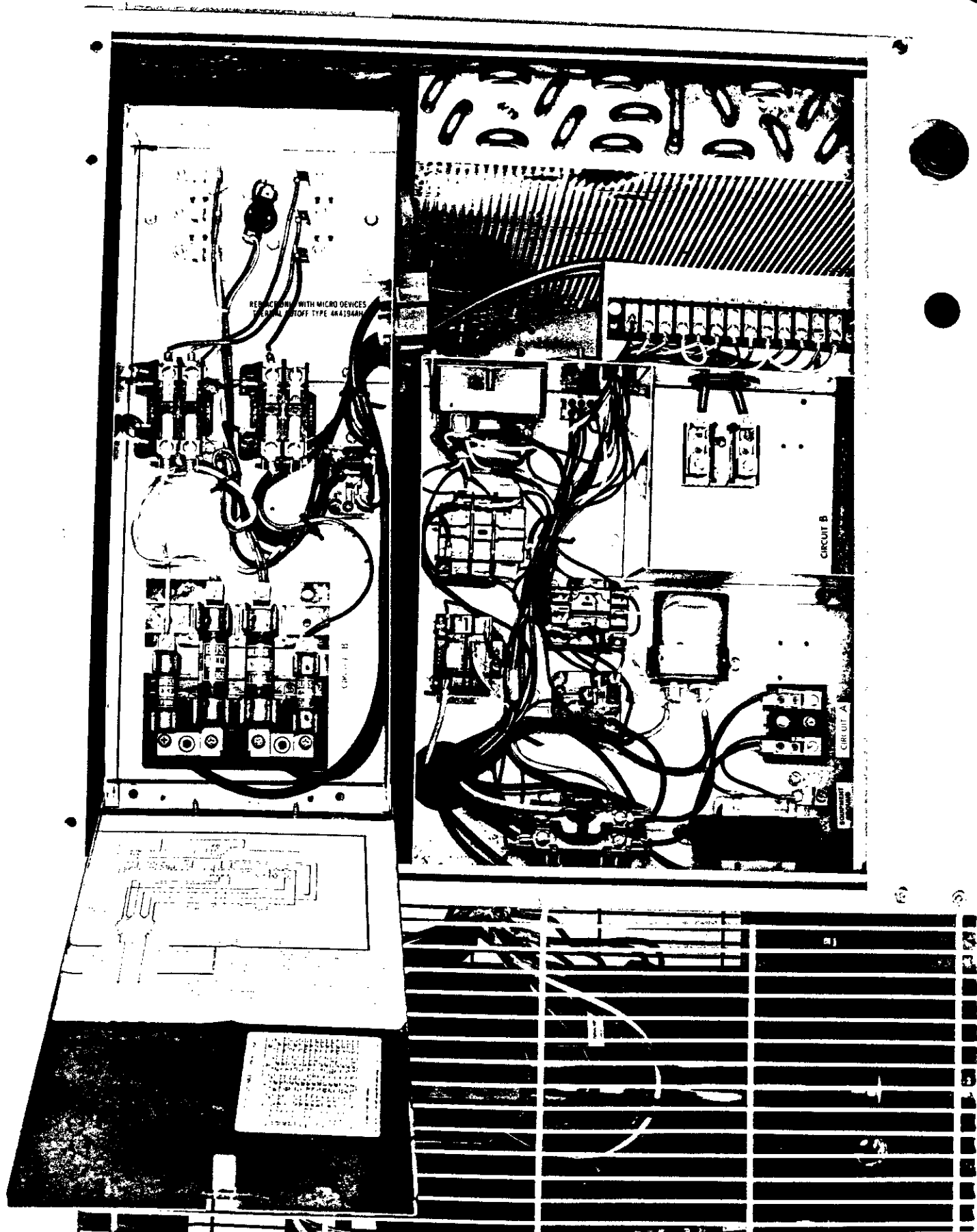

REDUCTION WITH MICRO DEVICES  
SERIAL OFFSET TYPE 4K4134AH

CIRCUIT B

CIRCUIT B

CIRCUIT A

Figure 3

Remove the unit control panel cover and the inner 4-1/4" x 7-3/4" cover. By removing this cover an isolated area is exposed. Install the high voltage terminal block. Use the two (2) #8-16 x 1" screws. Install the grounding lug, using the two (2) #10-24 x 1/2" screws into the prepunched holes supplied.

Route the line voltage power circuit wires from the heater package through the bushed hole in the control panel to the newly installed high voltage terminal block.

Inspect all wiring for damage and secure any loose wiring with the enclosed wire ties. See Figure 3 for completed assembly. Replace the terminal block cover, control box cover and blower service door.

Energize both power supplies and check for proper system operation.

PARTS LIST										
OPTIONAL ELECTRIC HEAT PACKAGES										
Part No.	Description	EH3PA-1-5A	EH3PA-1-10A	EH3PA-1-15A	EH3PA-3-9B	EH3PA-3-12B	EH3PA-3-15B	EH3PA-3-9C 460V	EH3PA-3-12C 460V	EH3PA-3-15C 460V
8401-006	Contactior 2P20	(1)	(1)	(2)	(1)	(1)	(2)			
8401-002	Contactior 3P25A							(1)	(1)	(1)
8614-017	Fuse Block			x						
8614-006	Fuse 30A			(2)						
8614-007	Fuse 60A			(2)						
8607-013	Terminal Block	x	x							
8607-014	Terminal Block				x	x	x	x	x	x
8402-026	Thermal Cut-off	(1)	(2)	(3)	(2)	(3)	(3)	(2)	(3)	(3)
8402-012	Limit Switch	x	x	x	x	x	x	x	x	x
8201-032	Blower Relay							x	x	x
8201-008	Blower Relay	x	x	x	x	x	x			
8604-042	Heat Strip 5Kw 240v	x								
8604-044	Heat Strip 10Kw 240v		x							
8604-047	Heat Strip 15Kw 240v			x			x			
8604-048	Heat Strip 9Kw 240v				x					
8604-046	Heat Strip 12Kw 240v					x				
8604-072	Heat Strip 9Kw 480v							x		
8604-051	Heat Strip 12Kw 480v								x	
8604-052	Heat Strip 15kw 480v									x

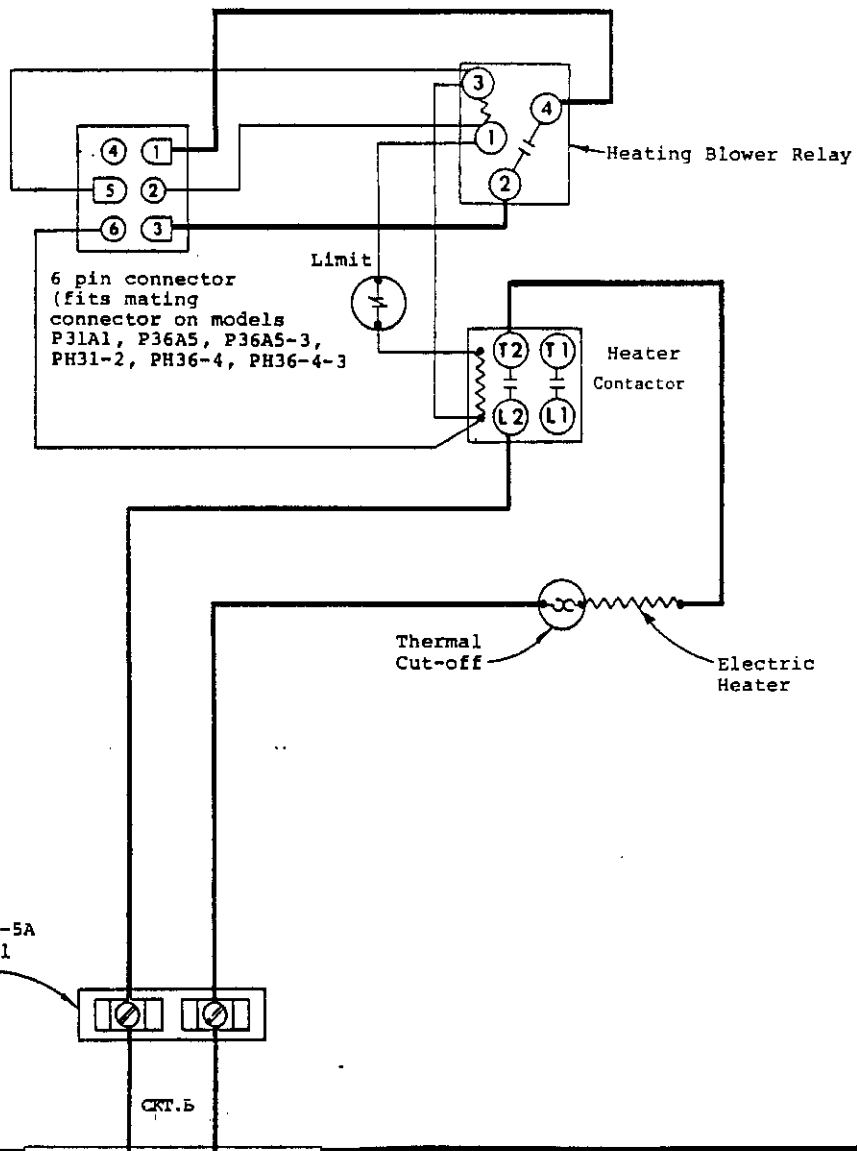

6 pin connector  
(fits mating  
connector on models  
P31A1, P36A5, P36A5-3,  
PH31-2, PH36-4, PH36-4-3)

Heating Blower Relay

Heater  
Contactor

Thermal  
Cut-off

Electric  
Heater

EH3PA-1-5A  
Terminal  
Block

CKT. B

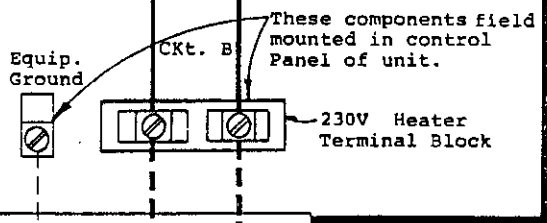

These components field  
mounted in control  
Panel of unit.

230V Heater  
Terminal Block

- ⚠ The EH3PA-1-5A heater package consists of the following:
- (1) Basic heater package.
  - (1) Terminal Block (Cat. No. EB or 11993).
  - (1) Listed Ground Terminal 6-12-AL, 6-14 CU.

\* 50HZ application not U.L. Listed  
Refer to the heat package instructions for proper  
installation.

USE COPPER OR  
ALUMINUM WIRE

⚠ EH3PA-1-5A  
HEATER PACKAGE

240-60-1  
240/220-50-1 \*

	FACTORY WIRING	FIELD WIRING
Low Voltage	————	-----
High Voltage	————	-----





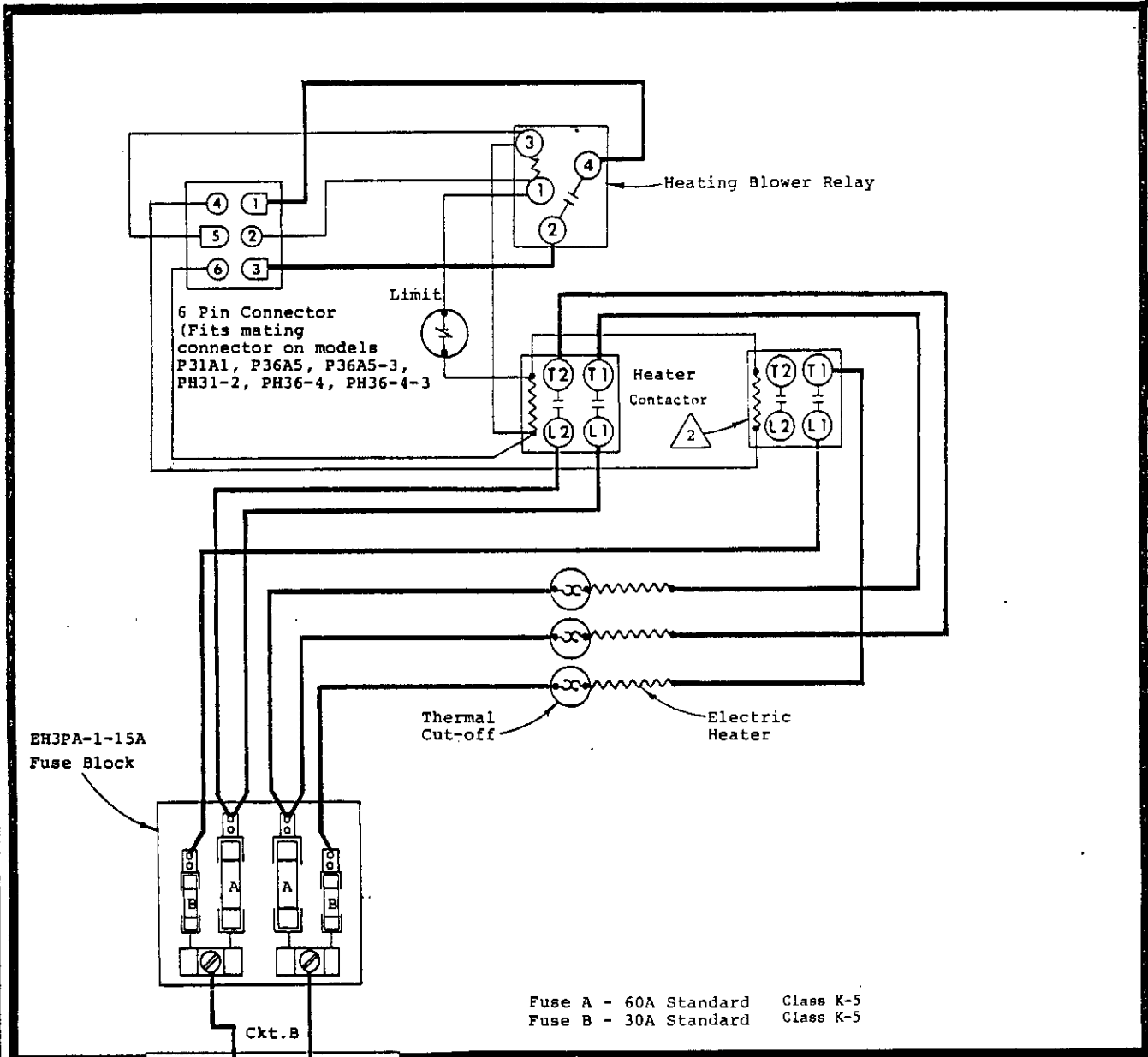

⚠ The EH3PA-1-15A heater package consists of the following:  
 (1) Basic heater package.  
 (1) Terminal Block (Cat.No. EB or 11993).  
 (1) Listed Ground Terminal 6-12 AL, 6-14 CU.  
 Refer to the heat package instructions for proper installation.

⚠ 2nd heat contactor operates only during emergency heat or compressor cut-off.

\*50HZ application not U.L. Listed

USE COPPER OR ALUMINUM WIRE

⚠ EH3PA-1-15A HEATER PACKAGE

FACTORY WIRING	FIELD WIRING
Low Voltage ———	-----
High Voltage ———	-----

4067-130B

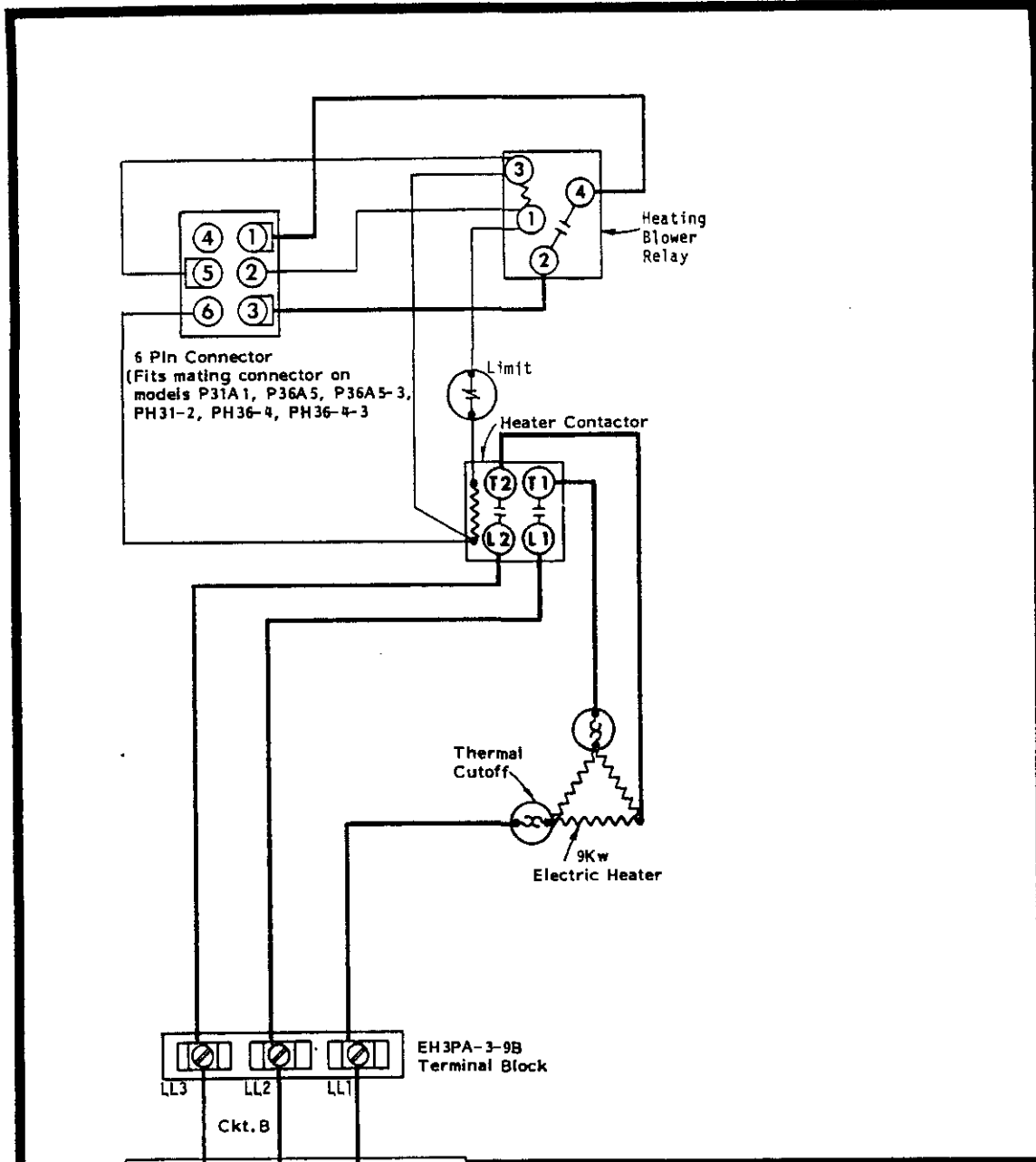

6 Pin Connector  
 (Fits mating connector on  
 models P31A1, P36A5, P36A5-3,  
 PH31-2, PH36-4, PH36-4-3)

Heating  
 Blower  
 Relay

Limit

Heater Contactor

Thermal  
 Cutoff

9Kw  
 Electric Heater

EH3PA-3-9B  
 Terminal Block

LL3 LL2 LL1

Ckt. B

These components  
 field mounted in  
 control panel of  
 unit.

230V Heater  
 Terminal Block

LL3 LL2 LL1

Ckt. B

Equip.  
 Ground

⚠ The EH3PA-3-9B Heater Package consists of the following:

- (1) Basic heater package
- (2) Terminal block (Cat. No. ERB or 11993)
- (3) Listed Ground Terminal 6-12AL, 6-14 CU

\*50HZ application not U.L. Listed

⚠ EH3PA-3-9B  
 HEATER PACKAGE

USE COPPER OR  
 ALUMINUM WIRE

240-60-3  
 240/220-50-3\*

FACTORY WIRING	FIELD WIRING
Low Voltage ———	-----
High Voltage ———	-----

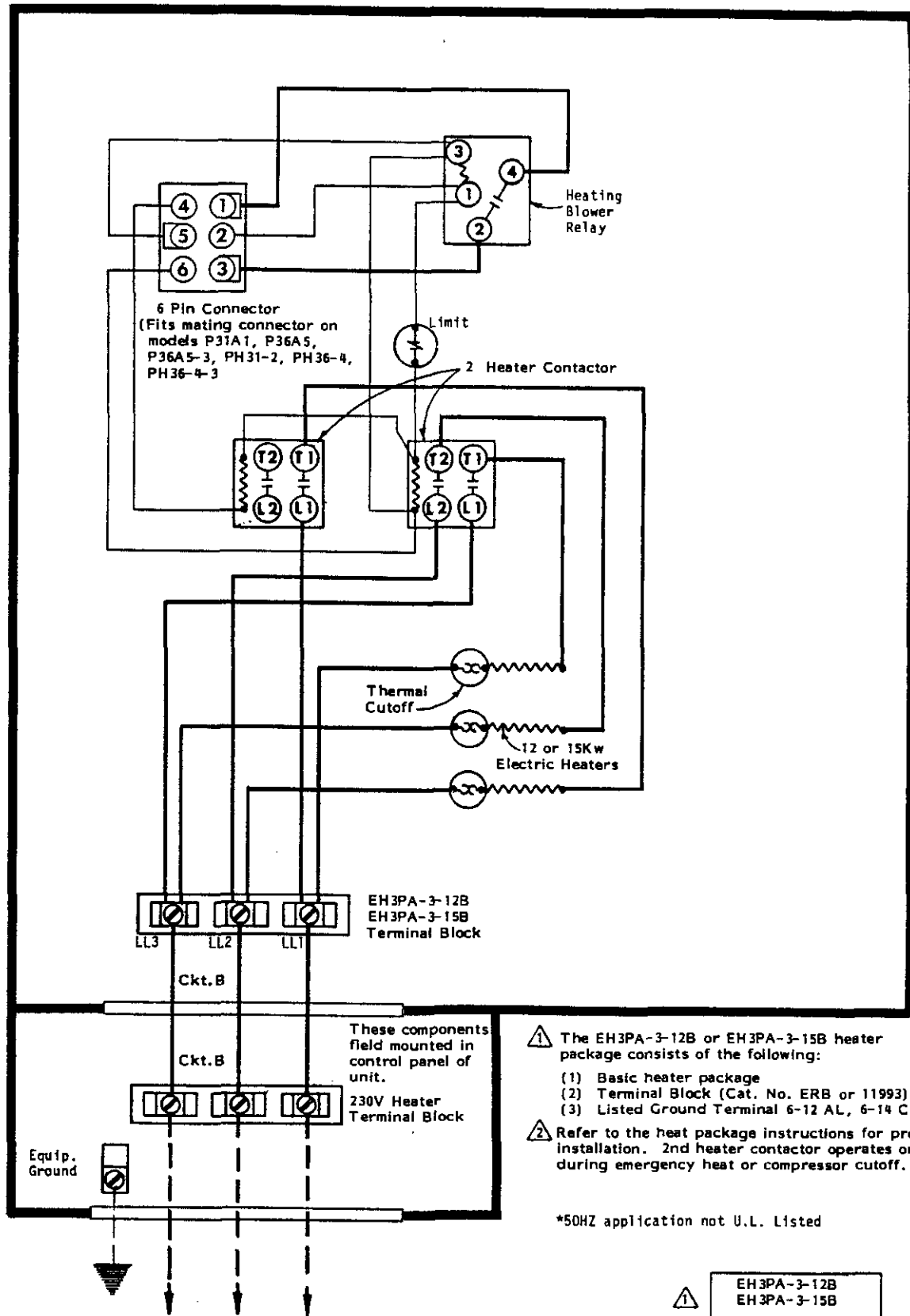

- ⚠ The EH3PA-3-12B or EH3PA-3-15B heater package consists of the following:
  - (1) Basic heater package
  - (2) Terminal Block (Cat. No. ERB or 11993)
  - (3) Listed Ground Terminal 6-12 AL, 6-14 CU
- ⚠ Refer to the heat package instructions for proper installation. 2nd heater contactor operates only during emergency heat or compressor cutoff.

\*50HZ application not U.L. Listed

⚠ EH3PA-3-12B  
EH3PA-3-15B  
HEATER PACKAGES

USE COPPER OR ALUMINUM WIRE

240-60-3  
240/220-50-3 \*

FACTORY WIRING	FIELD WIRING
Low Voltage ————	-----
High Voltage ————	-----

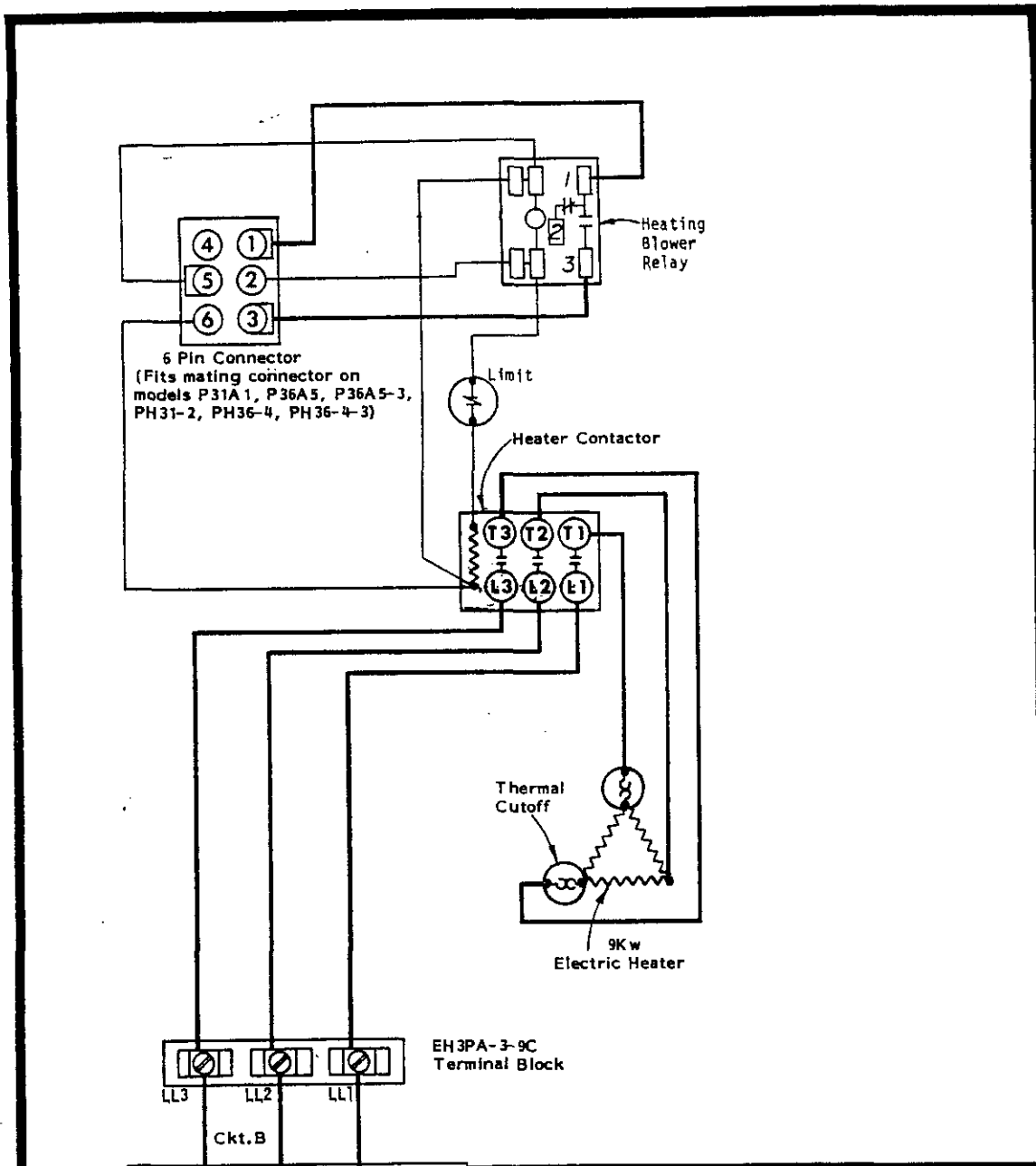

6 Pin Connector  
 (Fits mating connector on  
 models P31A1, P36A5, P36A5-3,  
 PH31-2, PH36-4, PH36-4-3)

Heating  
Blower  
Relay

Limit

Heater Contactor

Thermal  
Cutoff

9Kw  
Electric Heater

EH3PA-3-9C  
Terminal Block

LL3 LL2 LL1

Ckt. B

These components  
field mounted in  
control panel of  
unit.

460V Heater  
Terminal Block

Ckt. B

Equip.  
Ground

⚠ The EH3PA-3-9C heater package consists of the following:

- (1) Basic heater package
- (2) Terminal Block (Cat. No. ERB or 11993)
- (3) Listed Ground Terminal 6-12 AL, 6-14 CU



EH3PA-3-9C  
HEATER PACKAGE

USE COPPER OR  
ALUMINUM WIRE

480-60-3

FACTORY WIRING	FIELD WIRING
Low Voltage ———	-----
High Voltage ———	-----

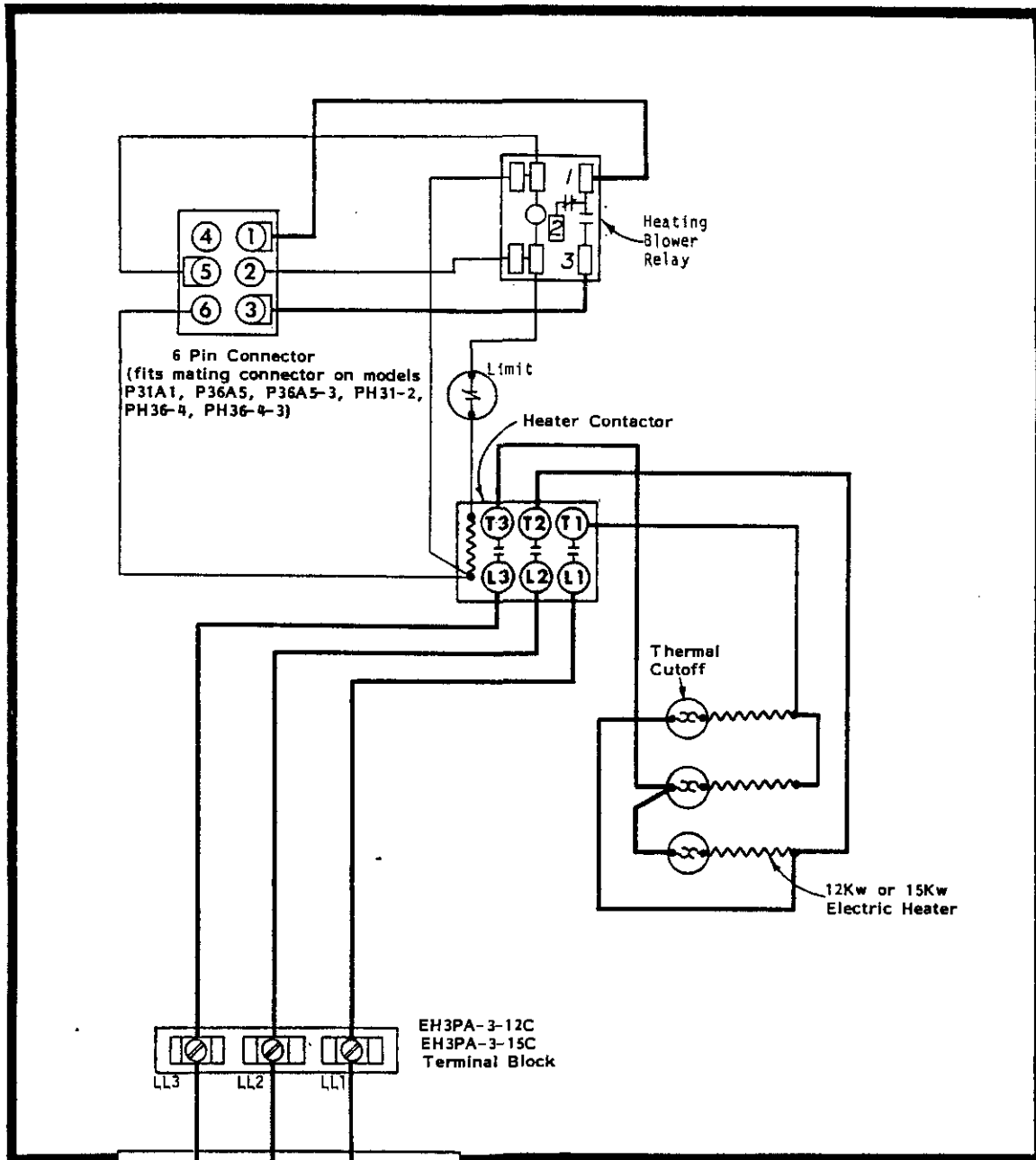

- ⚠ The EH3PA-3-12C or EH3PA-3-15C heater package consists of the following:
- (1) Basic heater package
  - (2) Terminal Block (Cat. No. ERB or 11993)
  - (3) Listed Ground Terminal 6-12 AL, 6-14 CU

⚠ EH3PA-3-12C  
EH3PA-3-15C  
HEATER PACKAGE

USE COPPER OR ALUMINUM WIRE

480-60-3

FACTORY WIRING	FIELD WIRING
Low Voltage ————	-----
High Voltage ————	-----