

INSTALLATION INSTRUCTIONS

MODELS

EH5PA-A05

EH5PA-A10

EH5PA-A15

EH5PA-A20

EH5PA-B09

EH5PA-B12

EH5PA-B15

EH5PA-B18

EH5PA-C09

EH5PA-C12

EH5PA-C15

EH5PA-C18

OPTIONAL ELECTRIC HEAT PACKAGES

FOR USE WITH 3.5, 4 and 5 TON
PACKAGED UNITS

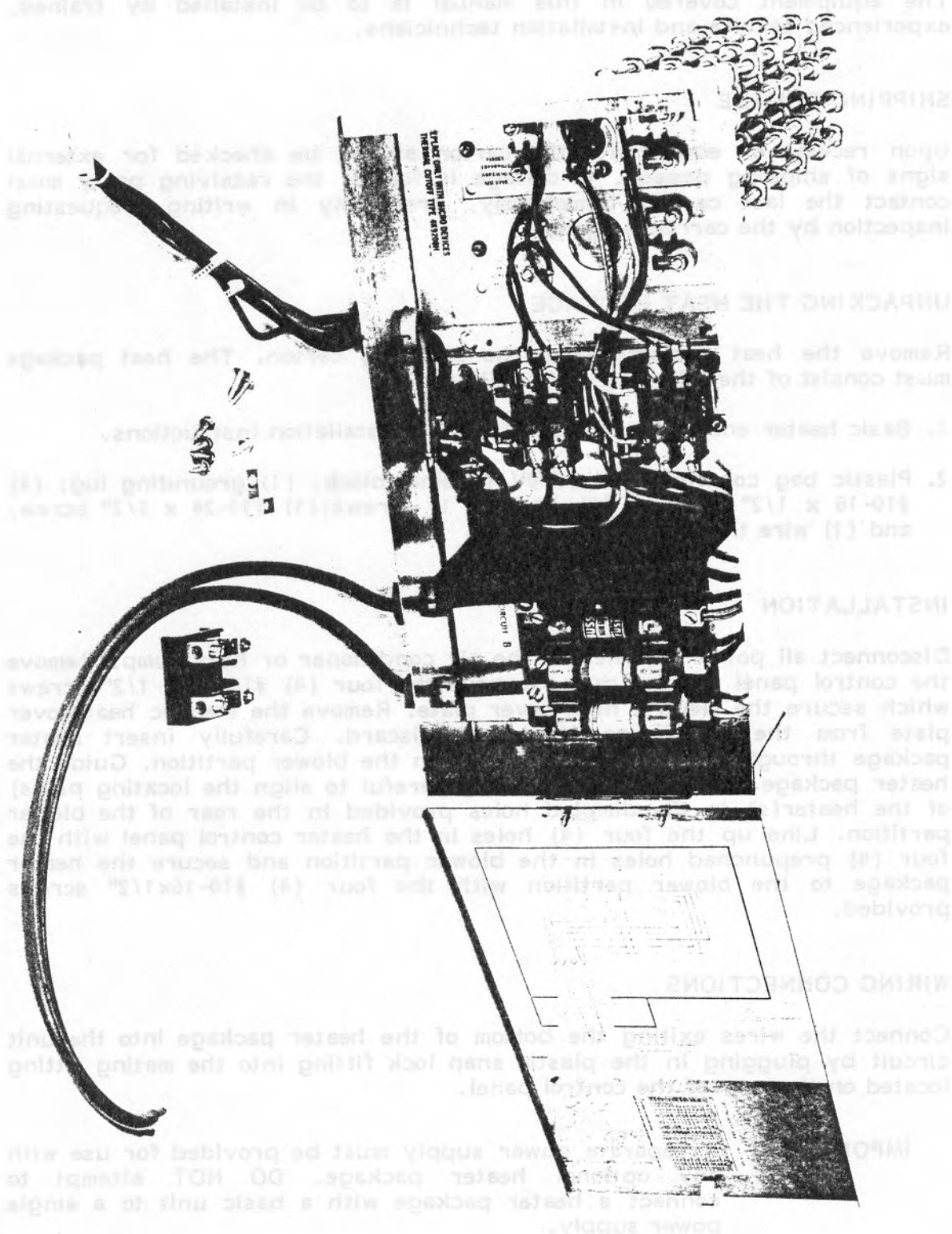

Figure 1

IMPORTANT

The equipment covered in this manual is to be installed by trained, experienced service and installation technicians.

SHIPPING DAMAGE

Upon receipt of equipment, the carton should be checked for external signs of shipping damage. If damage is found, the receiving party must contact the last carrier immediately, preferably in writing, requesting inspection by the carrier's agent.

UNPACKING THE HEAT PACKAGE

Remove the heat package from the shipping carton. The heat package must consist of the following: (See Figure 1)

1. Basic heater enclosure with controls and installation instructions.
2. Plastic bag containing (1) 230V terminal block; (1) grounding lug; (4) #10-16 x 1/2" screws; (2) #8-16 x 1" screws; (1) #10-24 x 1/2" screw; and (1) wire tie.

INSTALLATION

Disconnect all power supplies to the air conditioner or heat pump. Remove the control panel service door. Remove the four (4) #10-16 x 1/2" screws which secure the electric heat cover plate. Remove the electric heat cover plate from the blower partition and discard. Carefully insert heater package through the opening, provided in the blower partition. Guide the heater package into the opening being careful to align the locating pin(s) of the heater(s) in the dimpled holes provided in the rear of the blower partition. Line up the four (4) holes in the heater control panel with the four (4) prepunched holes in the blower partition and secure the heater package to the blower partition with the four (4) #10-16x1/2" screws provided.

WIRING CONNECTIONS

Connect the wires exiting the bottom of the heater package into the unit circuit by plugging in the plastic snap lock fitting into the mating fitting located on the rear of the control panel.

IMPORTANT: A separate power supply must be provided for use with any optional heater package. DO NOT attempt to connect a heater package with a basic unit to a single power supply.

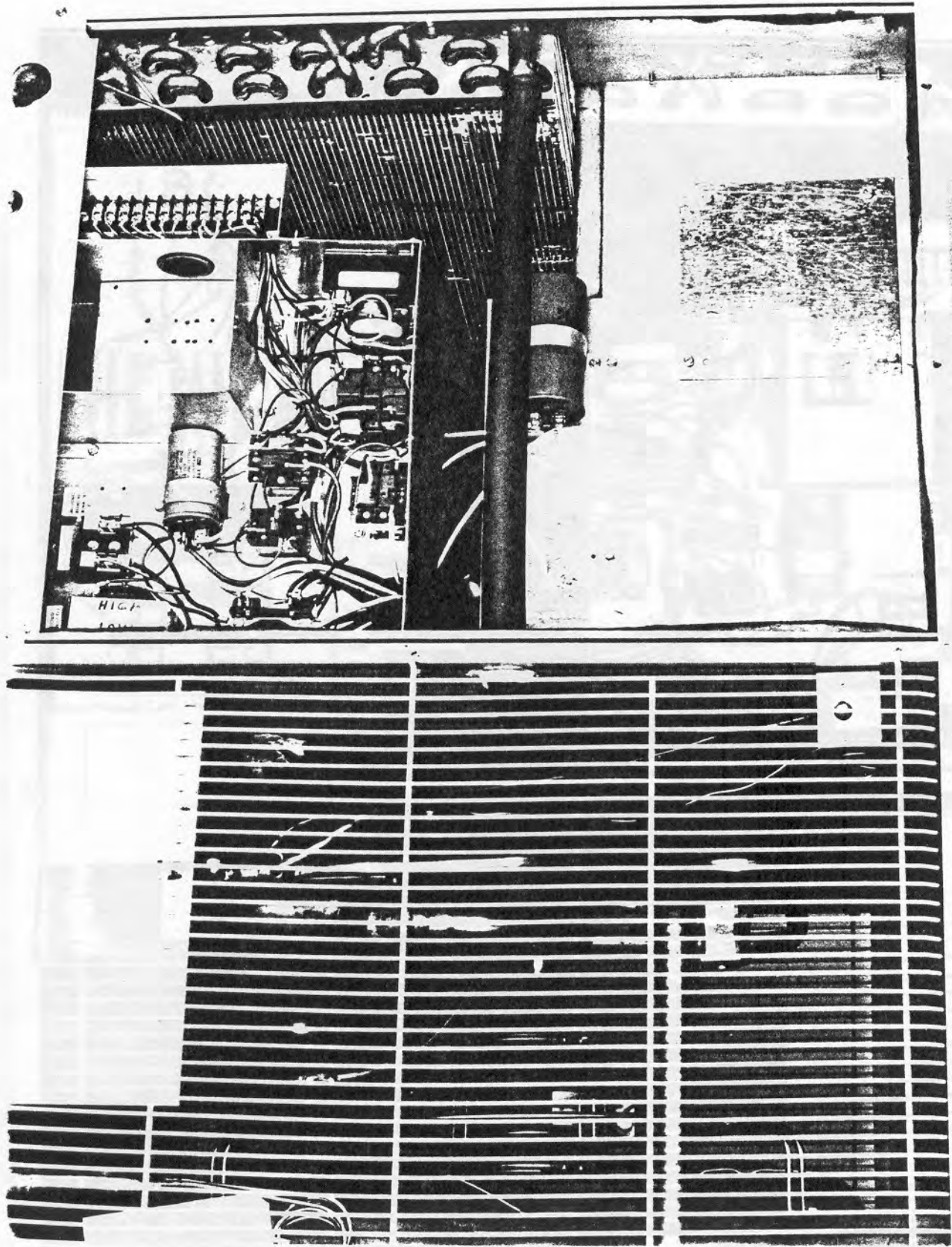

Figure 2

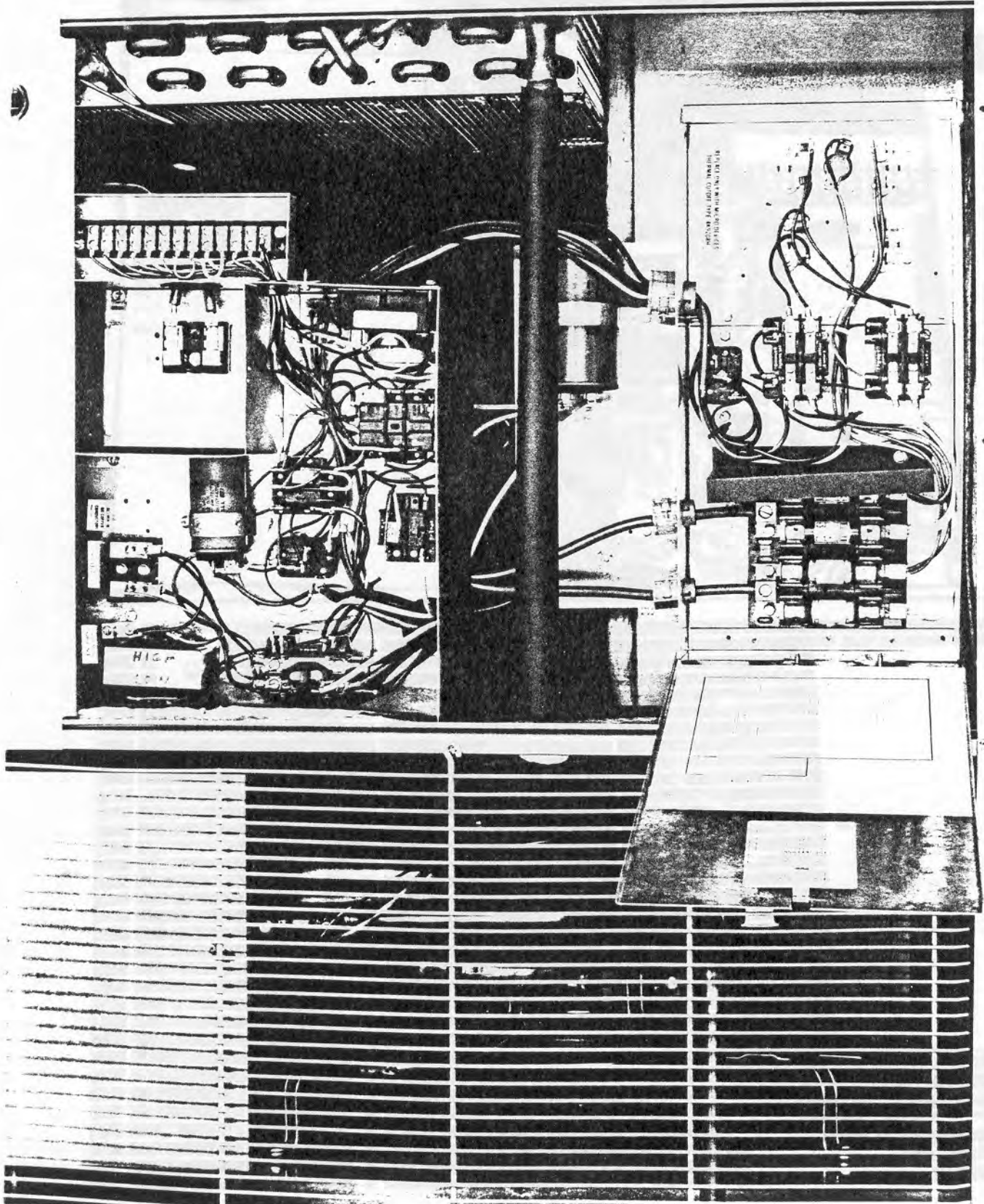

Figure 3

Remove the unit control panel cover and the inner 4-1/4" x 7-3/4" cover. By removing this cover an isolated area is exposed. Install the high voltage terminal block. Use the two (2) #8-16 x 1" screws. Install the grounding lug, using the two (2) #10-24 x 1/2" screws into the prepunched holes supplied.

Route the line voltage power circuit wires from the heater package through the bushed hole in the control panel to the newly installed high voltage terminal block.

Inspect all wiring for damage and secure any loose wiring with the enclosed wire ties. See Figure 3 for completed assembly. Replace the terminal block cover, control box cover and blower service door.

Energize both power supplies and check for proper system operation.

PARTS LIST													
OPTIONAL ELECTRIC HEAT PACKAGES													
Part No.	Description	EH5PA-A05	EH5PA-A10	EH5PA-A15	EH5PA-A20	EH5PA-B09	EH5PA-B12	EH5PA-B15	EH5PA-B18	EH5PA-C09	EH5PA-C12	EH5PA-C15	EH5PA-C18
8401-006	Contactor 2P20A	(1)	(1)	(2)	(2)	(1)	(2)	(2)	(2)				
8401-002	Contactor 3P25A									(1)	(1)	(1)	(2)
8614-017	Fuse Block			(1)									
8614-018	Fuse Block				(1)								
8402-025	Thermal Cutoff	(1)	(2)	(3)	(4)	(2)	(3)	(3)	(4)	(2)	(3)	(3)	(4)
8201-008	Blower Relay	x	x	x	x	x	x	x	x	x	x	x	x
8607-013	Terminal Block	x	x										
8607-014	Terminal Block					x	x	x	x	x	x	x	x
8614-006	Fuse 30A			(2)									
8614-007	Fuse 60A			(2)	(4)								
8402-012	Limit Switch	x	x	x	x	x	x	x	x	x	x	x	x
8604-042	Heat Strip 5kw	x											
8604-044	Heat Strip 10kw		x		(2)								
8604-047	Heat Strip 15kw			x				x					
8604-046	Heat Strip 12kw						x						
8604-048	Heat Strip 9kw					x			(2)				
8604-072	Heat Strip 9kw									x			(2)
8604-051	Heat Strip 12kw										x		
8604-052	Heat Strip 15kw											x	
4068-110	Wiring Diagram	x											
4068-120	Wiring Diagram		x										
4068-130	Wiring Diagram			x									
4068-140	Wiring Diagram				x								
4068-210	Wiring Diagram					x							
4068-220	Wiring Diagram						x	x					
4068-230	Wiring Diagram								x				
4068-310	Wiring Diagram									x			
4068-320	Wiring Diagram										x	x	
4068-330	Wiring Diagram												x

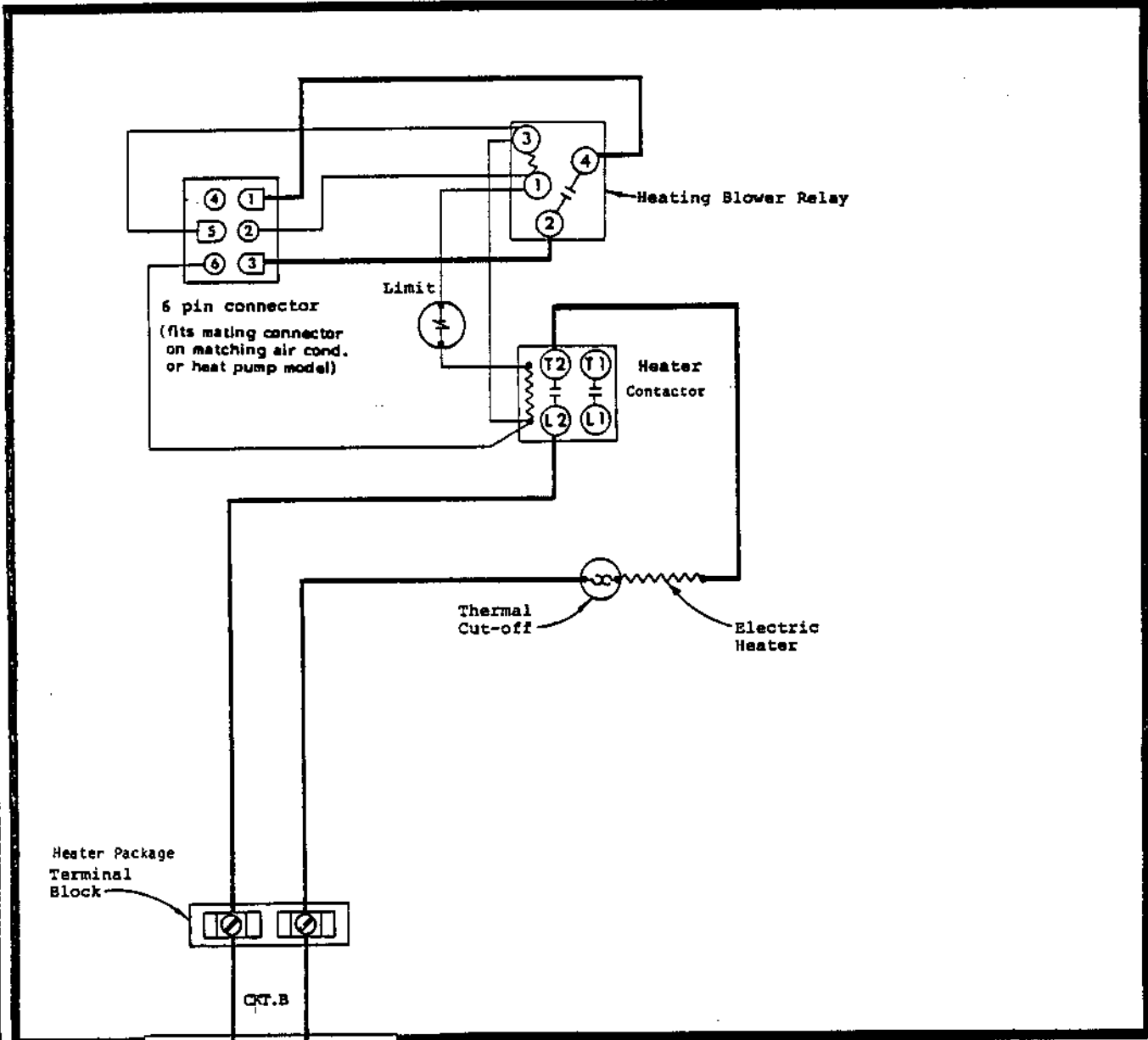

Heater Package Terminal Block

6 pin connector
(fits mating connector on matching air cond. or heat pump model)

Heating Blower Relay

Limit

Heater Contactor

Thermal Cut-off

Electric Heater

CT.B

Equip. Ground

CKT. B

These components field mounted in control Panel of unit.

230V Heater Terminal Block



This heater package consists of the following:

- (1) Basic heater package.
- (1) Terminal Block (Cat. No. EB or 11983).
- (1) Listed Ground Terminal 6-12 AL, 6-14 CU.

Refer to the heat package instructions for proper installation.

*50HZ application not U.L. Listed

USE COPPER OR ALUMINUM WIRE

FACTORY WIRING	FIELD WIRING
Low Voltage _____	Low Voltage - - - - -
High Voltage _____	High Voltage - - - - -

240/208-60-1
240/220-50-1*

4068-110 E

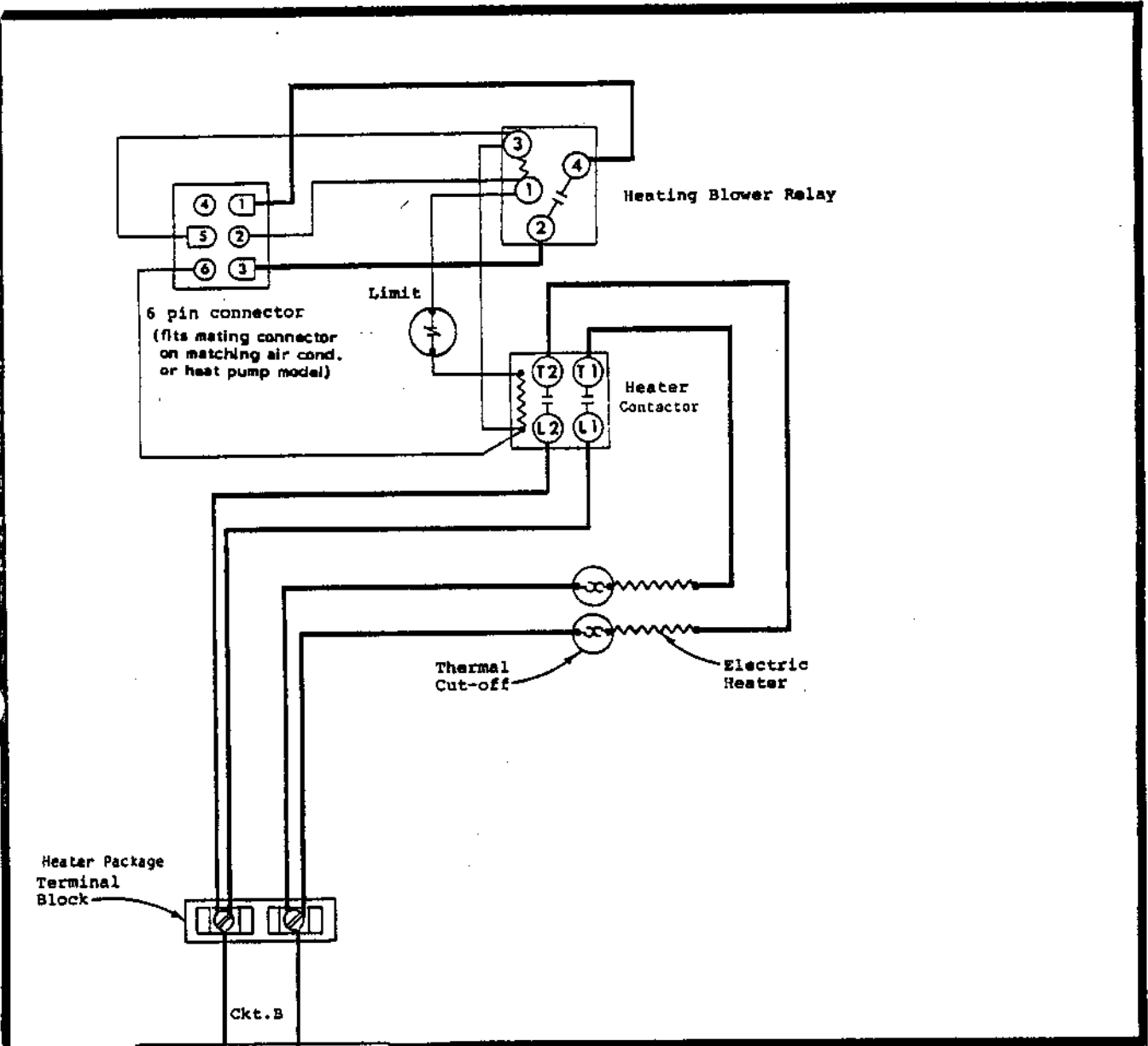

⚠ This heater package consists of the following:

- (1) Basic heater package.
- (1) Terminal Block (Cat.No. EB or 11993).
- (1) Listed Ground Terminal 6-12AL, 6-14 CU.

*50HZ application not U.L. Listed
Refer to the heat package instructions for proper installation.

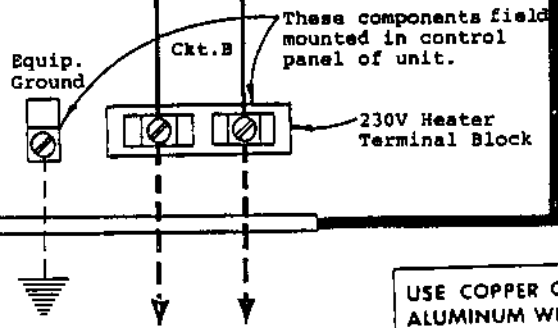

USE COPPER OR ALUMINUM WIRE

240/208-60-1
240/220-50-1 *

	FACTORY WIRING	FIELD WIRING
Low Voltage	—————	-----
High Voltage	—————	-----

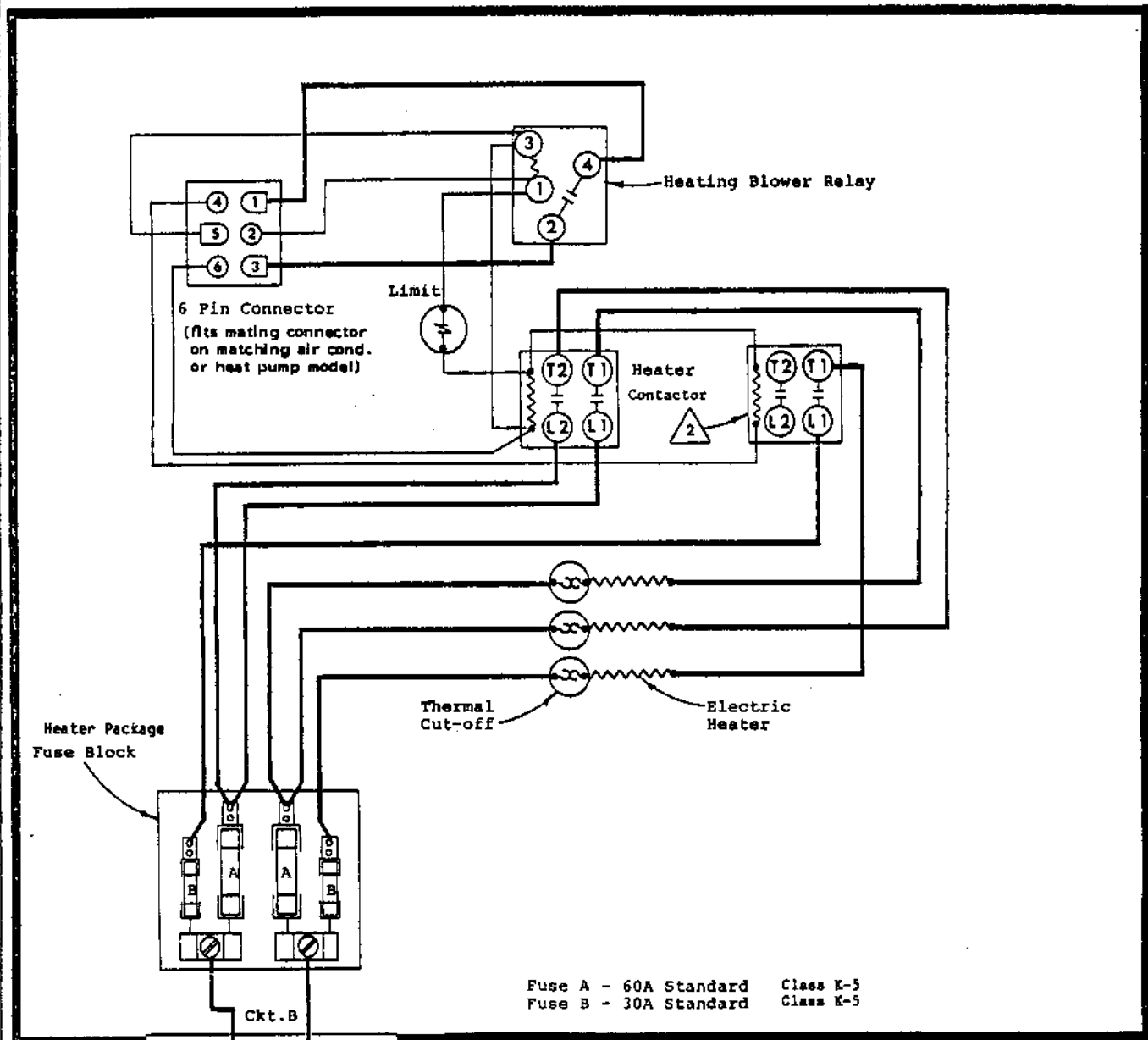

Fuse A - 60A Standard Class K-5
 Fuse B - 30A Standard Class K-5

- ⚠ This heater package consists of the following:
- (1) Basic heater package.
 - (1) Terminal Block (Cat.No. EB or 11993).
 - (1) Listed Ground Terminal 6-12 AL, 6-14 CU.

Refer to the heat package instructions for proper installation.

- ⚠ 2nd heat contactor operates only during emergency heat or compressor cut-off.

*50HZ application not U.L. Listed

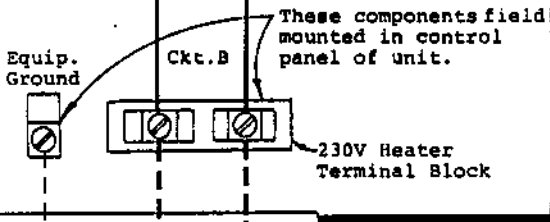

USE COPPER OR ALUMINUM WIRE

	FACTORY WIRING	FIELD WIRING
Low Voltage	—————	-----
High Voltage	—————	-----

240/208-60-1
 240/220-50-1 *

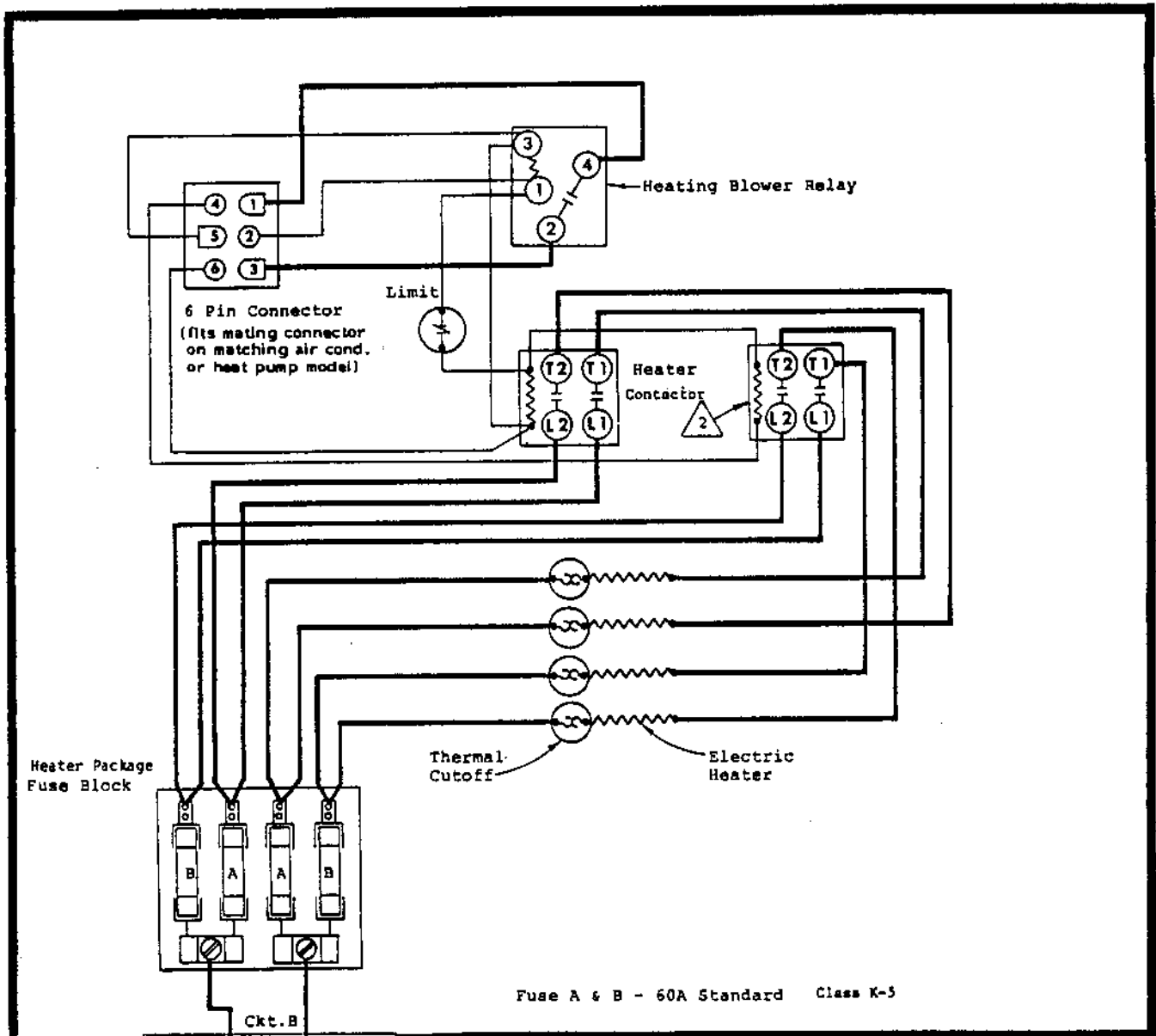

Fuse A & B - 60A Standard Class K-5

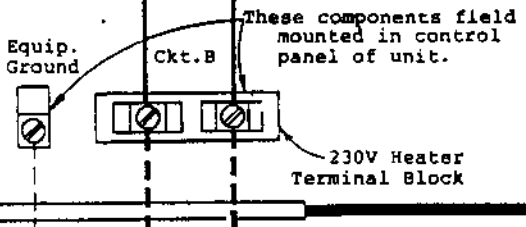

- ⚠ This heater package consists of the following:
 - (1) Basic heater package.
 - (1) Terminal Block (Cat. No. EB or 11993).
 - (1) Listed Ground Terminal 6-12 AL, 6-14 CU.
 Refer to the heat package instructions for proper installation.

- ⚠ 2nd heat contactor operates only during emergency heat or compressor cut-off.
- *50HZ application not U.L. Listed

USE COPPER OR ALUMINUM WIRE

	FACTORY WIRING	FIELD WIRING
Low Voltage	_____	-----
High Voltage	=====	-----

240/208-80-1
240/230-50-1 *

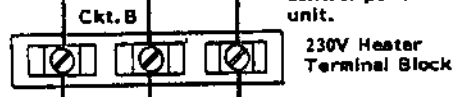
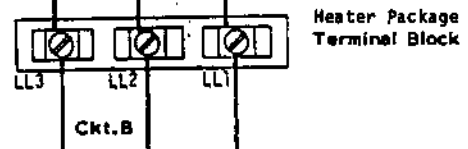
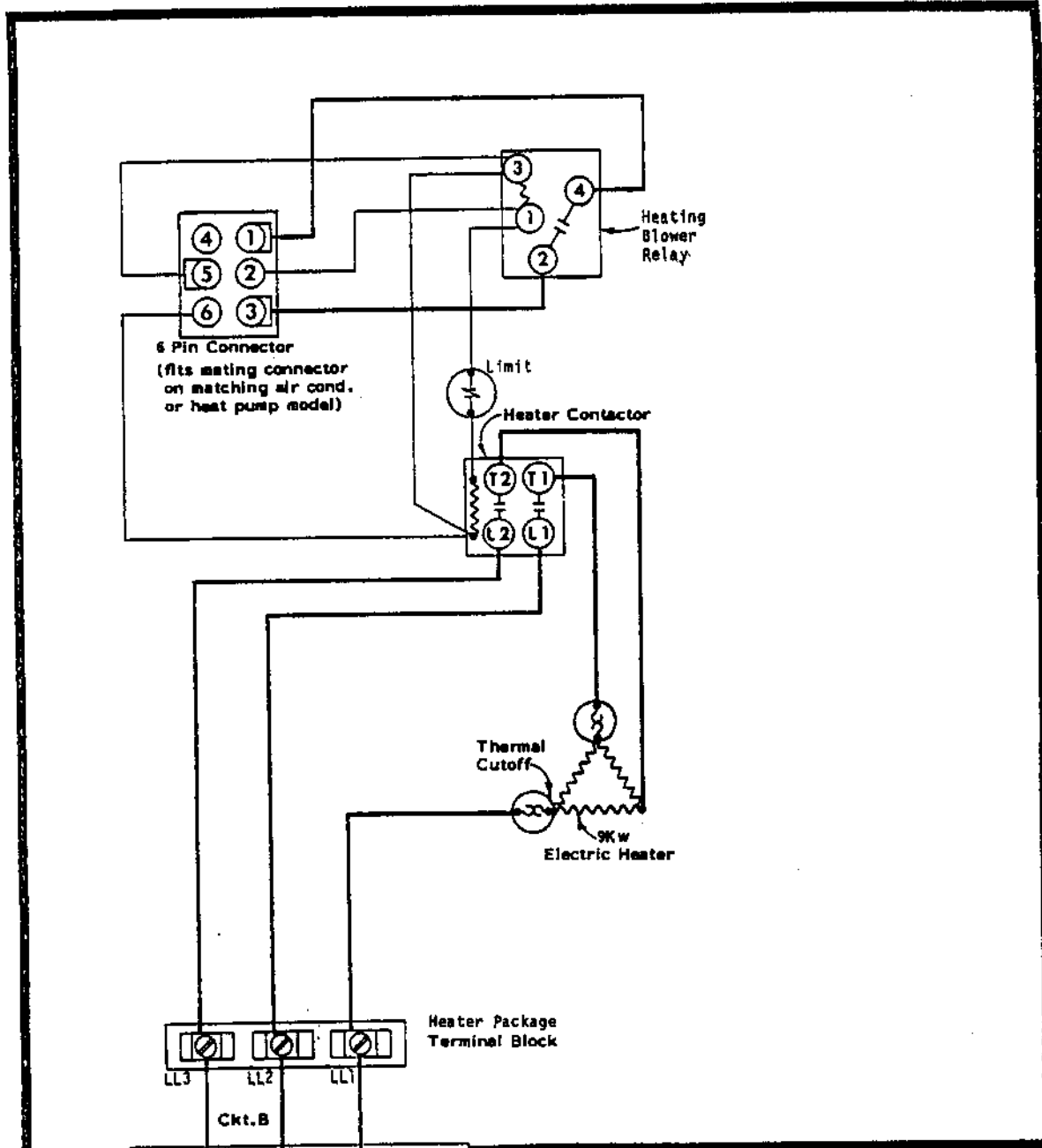

These components field mounted in control panel of unit.

⚠ This heater package consists of the following:

- (1) Basic heater package
- (2) Terminal Block (Cat. No. ERB or 11993)
- (3) Listed Ground Terminal 6-12 AL, 6-14 CU

*50HZ application not U.L. Listed

USE COPPER OR ALUMINUM WIRE

240/208-60-3
240/220-50-3 *

FACTORY WIRING	FIELD WIRING
Low Voltage ————	-----
High Voltage ————	-----

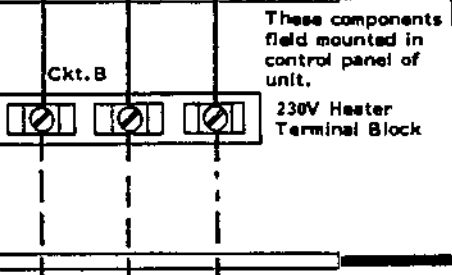
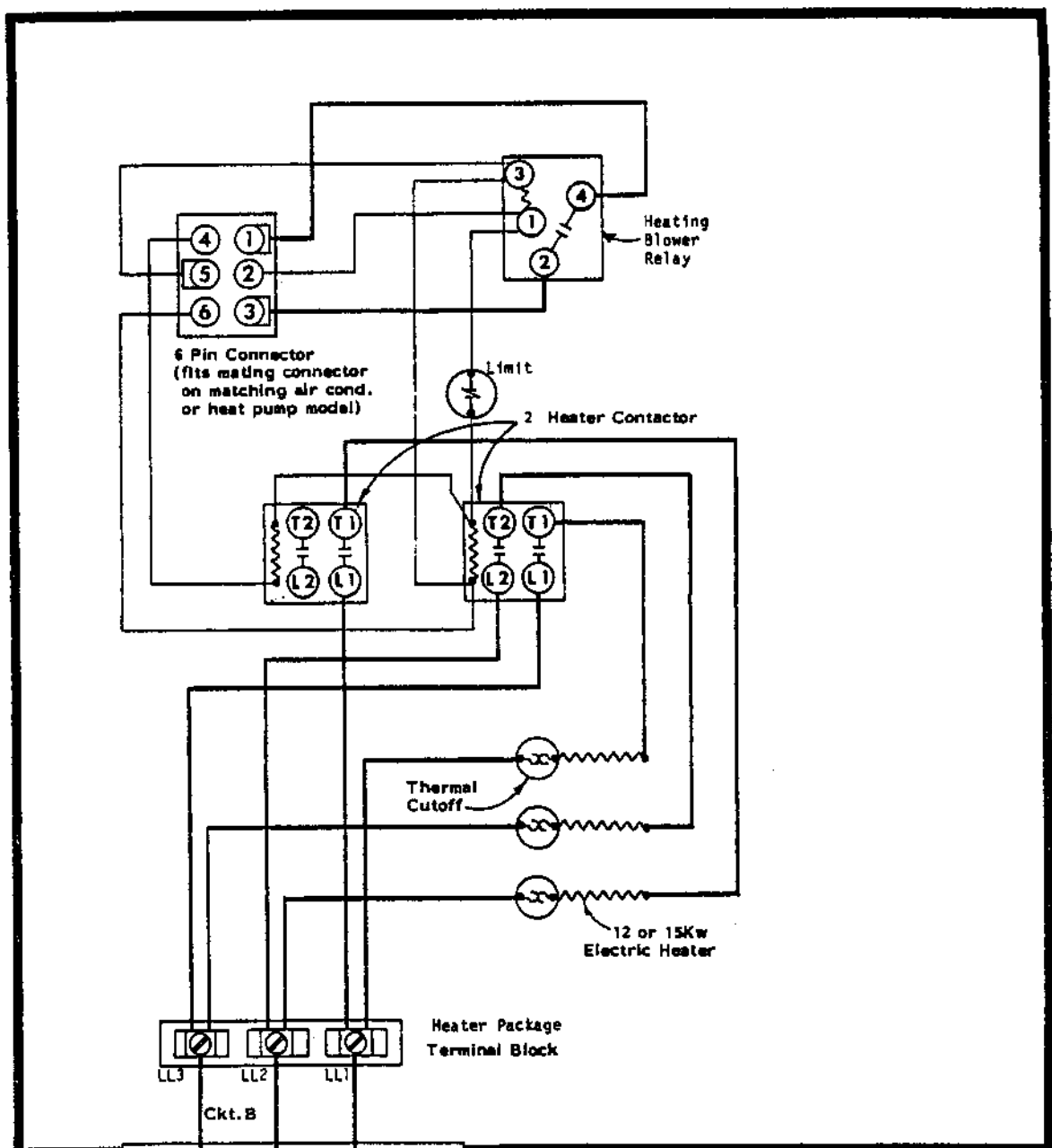

⚠ This heater package consists of the following:

- (1) Basic heater package
- (2) Terminal Block (Cat. No. ERB or 11993)
- (3) Listed Ground Terminal 6-12 AL, 6-18 CU

⚠ Refer to the heat package instructions for proper installation. 2nd heater contactor operates only during emergency heat or compressor cutoff.

*50HZ application not U.L. Listed

USE COPPER OR ALUMINUM WIRE

240/208-60-3
240/220-50-3 *



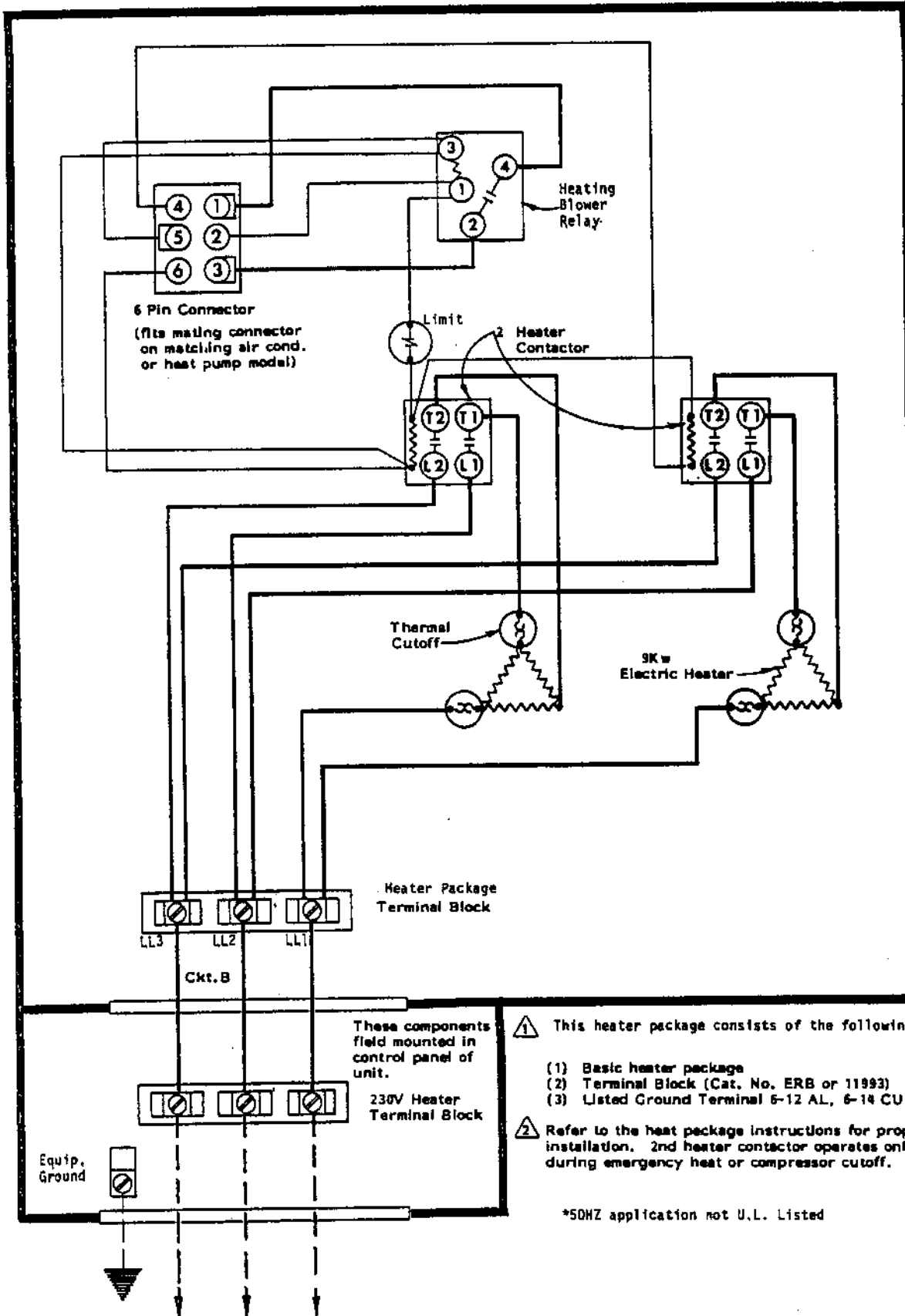

These components field mounted in control panel of unit.

⚠ This heater package consists of the following:

- (1) Basic heater package
- (2) Terminal Block (Cat. No. ERB or 11993)
- (3) Listed Ground Terminal 6-12 AL, 6-14 CU

⚠ Refer to the heat package instructions for proper installation. 2nd heater contactor operates only during emergency heat or compressor cutoff.

*50HZ application not U.L. Listed

USE COPPER OR ALUMINUM WIRE

240/208-60-3
240/220-50-3 *

FACTORY WIRING	FIELD WIRING
Low Voltage	-----
High Voltage	-----

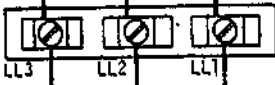
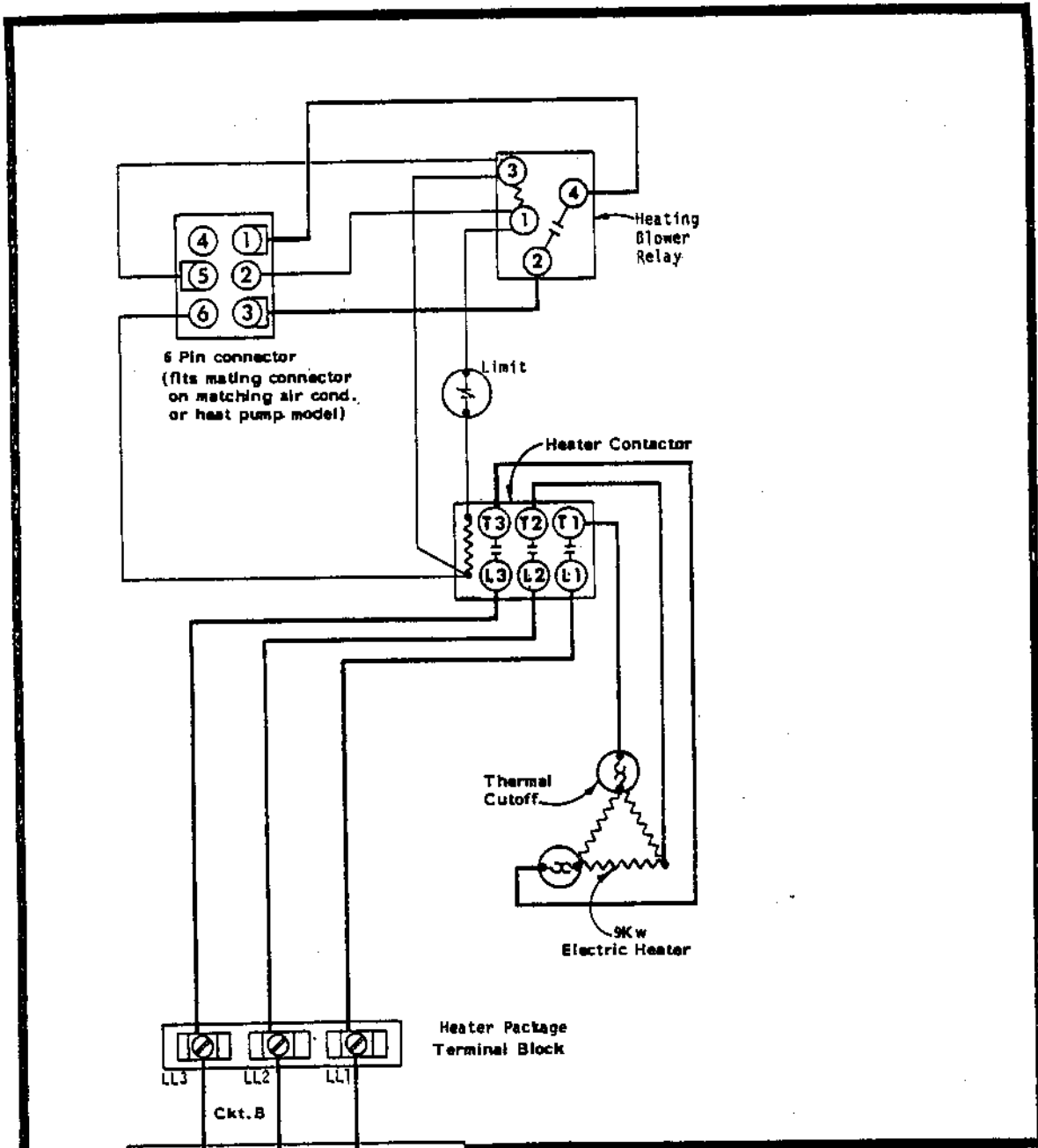

Ckt. B

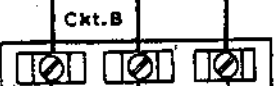

Ckt. B



These components field mounted in control panel of unit.

460V Heater Terminal Block

⚠ This heater package consists of the following:

- (1) Basic heater package
- (2) Terminal Block (Cat. No. ERB or 11993)
- (3) Listed Ground Terminal 6-12 AL, 6-14 CU

USE COPPER OR ALUMINUM WIRE

FACTORY WIRING	FIELD WIRING
Low Voltage	-----
High Voltage	-----

480-60-3

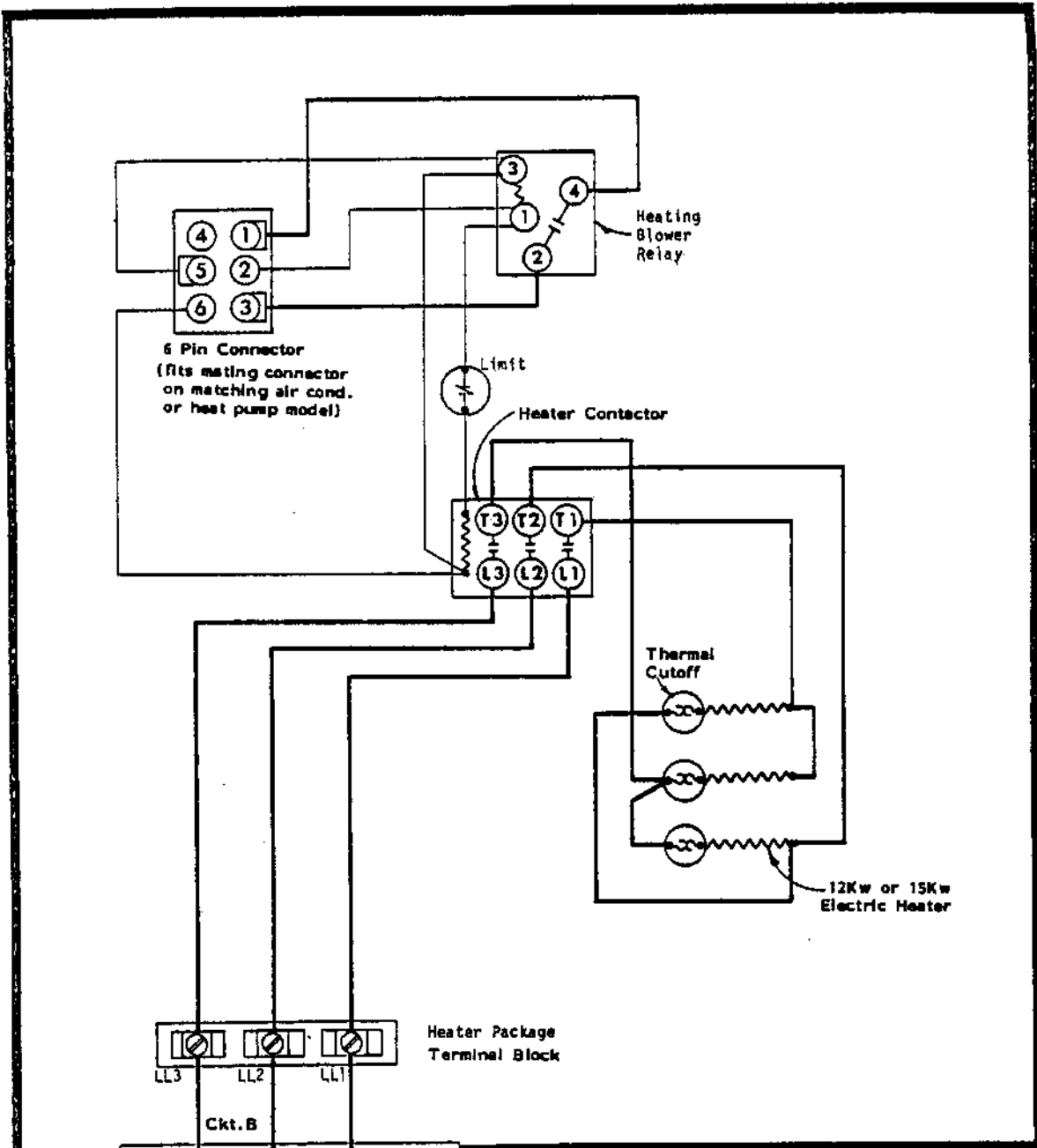

Heater Package Terminal Block
LL3 LL2 LL1

Ckt. B

460V Heater Terminal Block
Ckt. B

Equip. Ground

These components field mounted in control panel of unit.

⚠ This heater package consists of the following:

- (1) Basic heater package
- (2) Terminal Block (Cat. No. ERB or 11993)
- (3) Listed Ground Terminal 6-12 AL, 6-14 CU

480-60-3

USE COPPER OR ALUMINUM WIRE

FACTORY WIRING	FIELD WIRING
Low Voltage	-----
High Voltage	-----

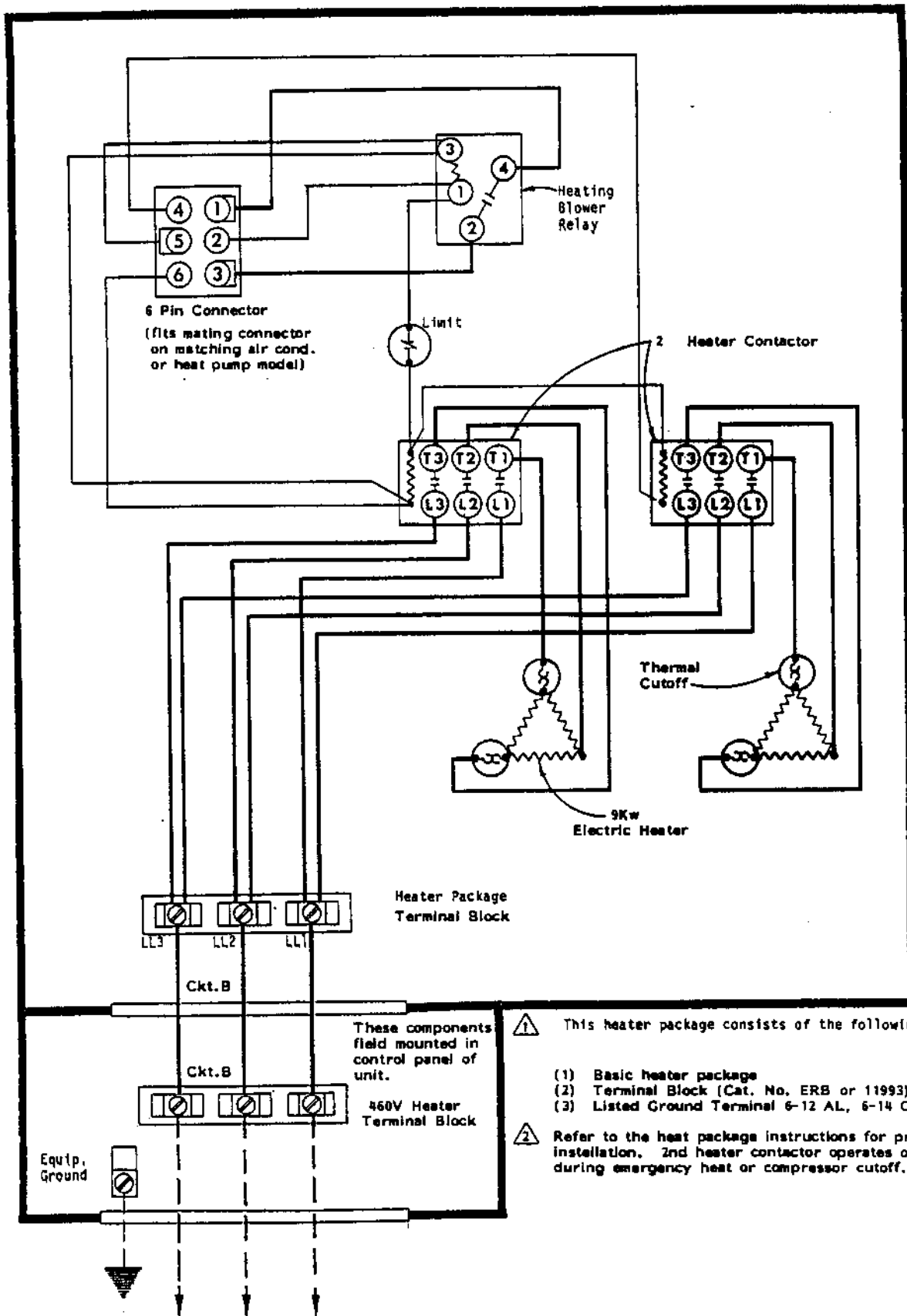

These components field mounted in control panel of unit.

⚠ This heater package consists of the following:

- (1) Basic heater package
- (2) Terminal Block (Cat. No. ERB or 11993)
- (3) Listed Ground Terminal 6-12 AL, 6-14 CU

⚠ Refer to the heat package instructions for proper installation. 2nd heater contactor operates only during emergency heat or compressor cutoff.

480-60-3

USE COPPER OR ALUMINUM WIRE

FACTORY WIRING	FIELD WIRING
Low Voltage	-----
High Voltage	-----