

Time pump cycle time should be 2 min.

MANUAL 2100-102B

NOTE: MAY NEED TO INCREASE TANK SIZE

INSTALLATION INSTRUCTIONS

HIGH EFFICIENCY WATER SOURCE PACKAGED HEAT PUMPS

MODELS

WPV30A	WPV53A
*WPVD30A	*WPVD53A
WPV36A	WPV62A
*WPVD36A	*WPVD62A

*Built-in hot water heat exchanger.

GROUND WATER TEMPERATURES 45-75°F

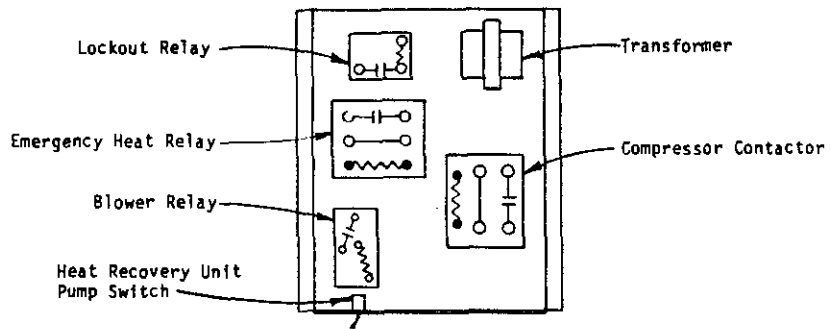

CONTROL PANEL

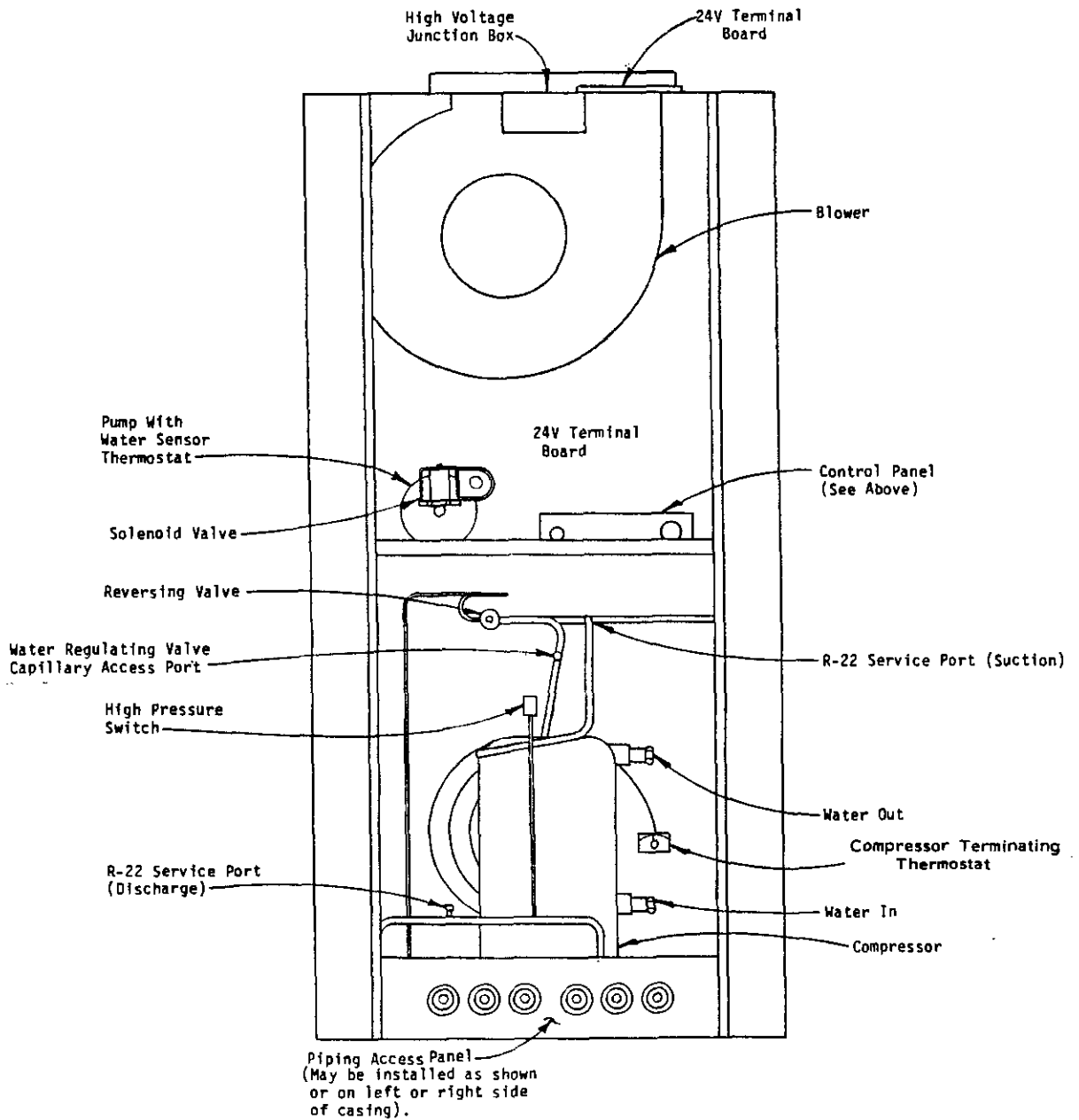

NOTE: If no return air duct is used, applicable installation codes may limit this cabinet to installation only in a single story structure.

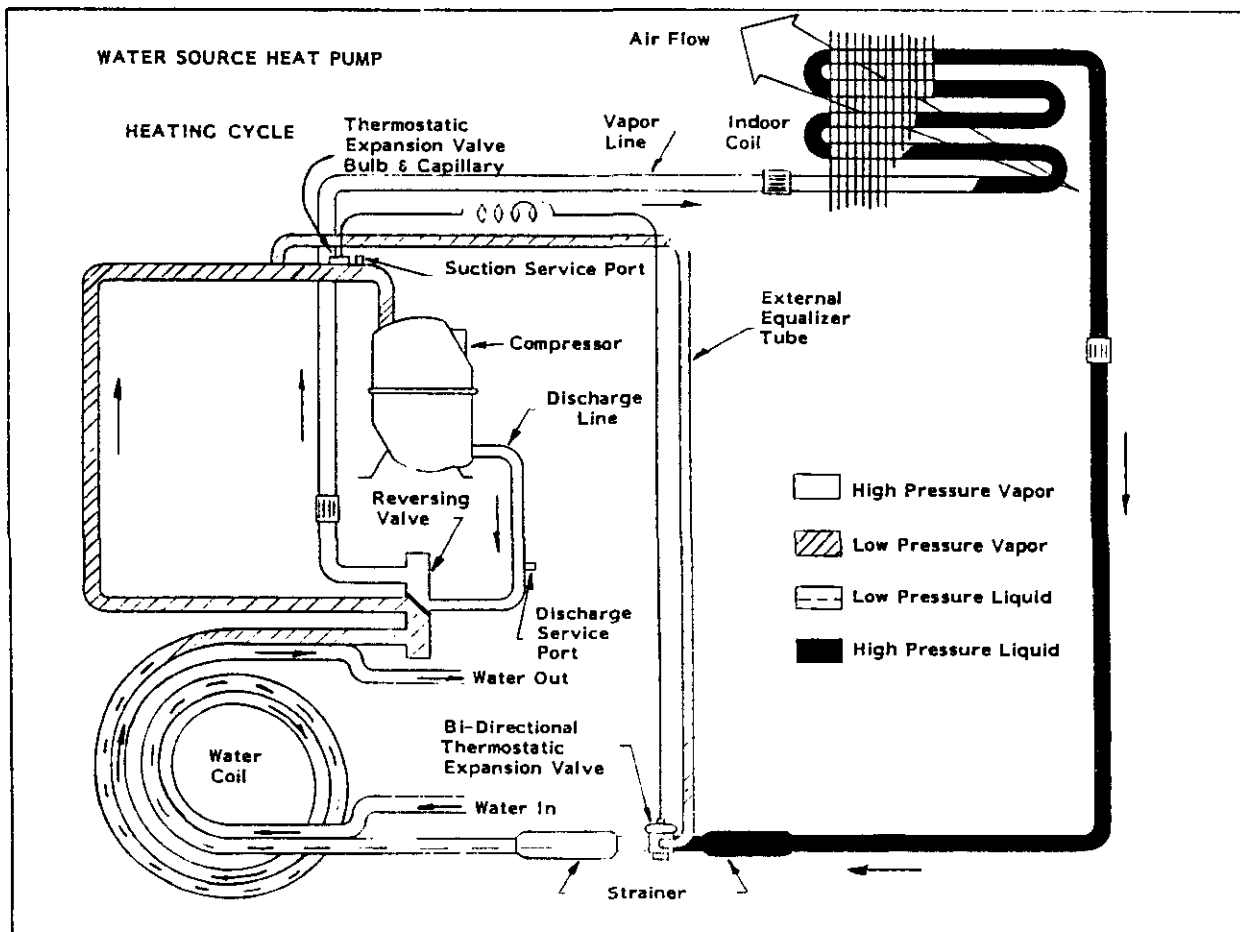
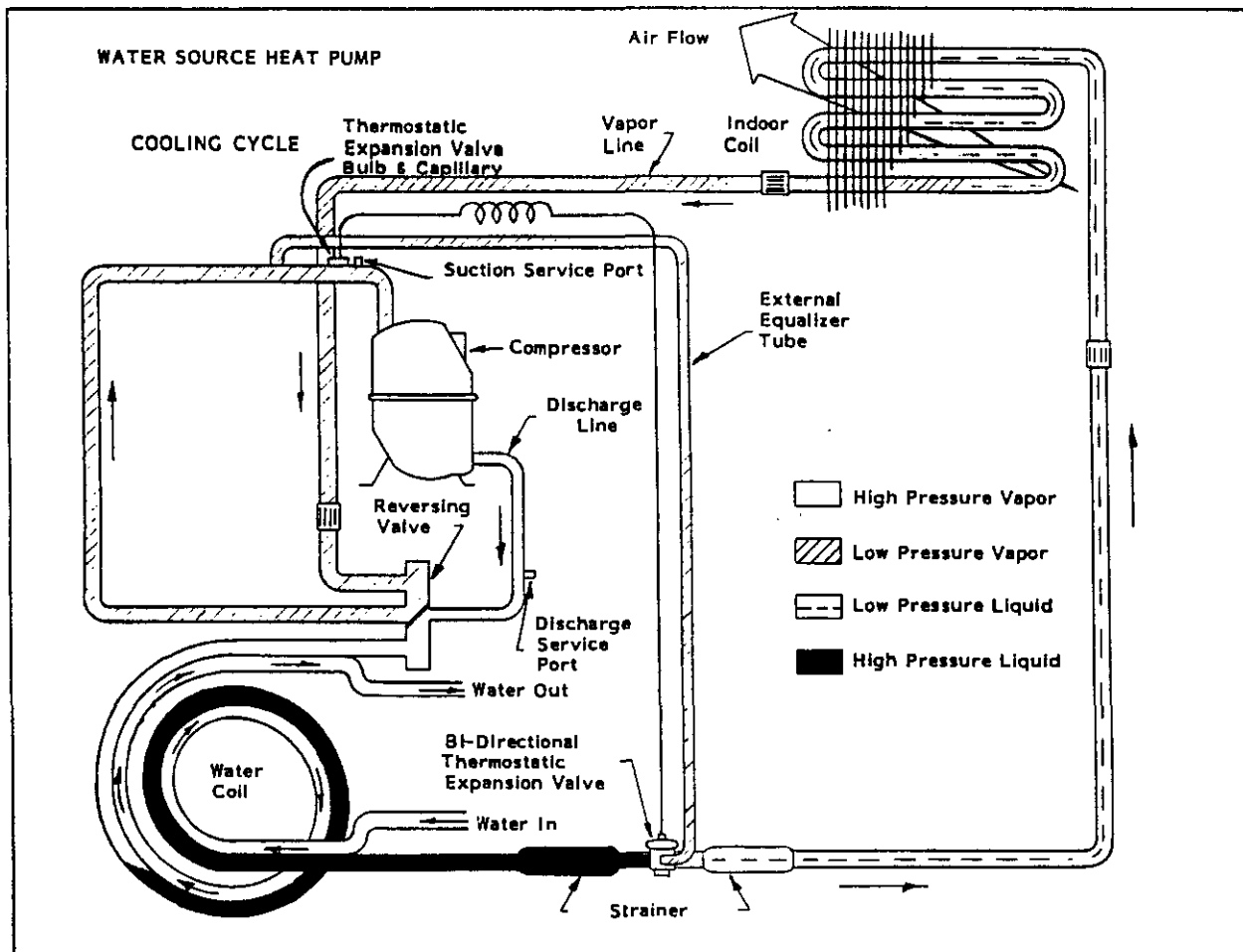

GENERAL

Units are shipped completely assembled and internally wired, requiring only duct connections, thermostat wiring, 230-208 volt AC power wiring, and water piping. The equipment covered in this manual is to be installed by trained, experienced service and installation technicians. Any heat pump is more critical of proper refrigerant charge and an adequate duct system than a cooling only air conditioning unit.

These instructions and any instructions packaged with any separate equipment required to make up the entire heat pump system should be carefully read before beginning the installation. Note particularly any tags and/or labels attached to the equipment.

While these instructions are intended as a general recommended guide, they do not in any way supersede any national and/or local codes. Authorities having jurisdiction should be consulted before the installation is made.

UNPACKING

Upon receipt of the equipment, the carton should be checked for external signs of shipping damage. If damage is found, the receiving party must contact the last carrier immediately, preferably in writing, requesting inspection by the carrier's agent.

INSTALLATION

1. BTUH CAPACITY SELECTION

Capacity of the unit for a proposed installation should be based on heat loss calculations made in accordance with methods of the Air Conditioning Contractors of America, formerly National Warm Air Heating and Air Conditioning Association. The air duct system should be sized and installed in accordance with Standards of the National Fire Protection Association For The Installation of Air Conditioning and Ventilating Systems of Other Than Residence Type NFPA No. 90A, and Residence Type Warm Air Heating and Air Conditioning Systems, NFPA No. 90B.

2. SITE SELECTION

The unit may be installed in a basement, closet or utility room provided adequate service access is insured. Ideally, three sides of the unit should have a minimum access clearance of two feet but the unit can be adequately serviced if two or only one side has the minimum two feet clearance. The unit should be located in the conditioned space to prevent freezing of the water lines and to permit proper, automatic shut off of the water regulating valves.

Clearance to combustible materials is 0 inches for the heat pump. If an optional duct heater is installed, follow the instructions packed with the duct heater for specifications regarding clearance to combustible material.

Before setting the unit, consider ease of piping, drain and electrical connections for the unit. Also, for units with heat recovery unit, consider the proximity of the unit to the water heater or storage tank. Place the unit on a solid base, preferably concrete, to minimize undesirable noise and vibration. DO NOT elevate the base pan on rubber or cork vibration eliminator pads as this will permit the unit base to act like a drum, transmitting objectionable noise.

3. DUCTWORK

If the unit is to be installed in a closet or utility room which does not have a floor drain, a secondary drain pan under the entire unit is highly recommended.

DO NOT install the unit in such a way that a direct path exists between any return grille and the unit. Rather, insure that the air entering the return grille will make at least one turn before entering the unit air coil. This will reduce possible objectionable compressor and air noise from entering the occupied space.

Design the ductwork according to methods given by the National Warm Air Heating and Air Conditioning Association. When duct runs through unconditioned spaces, it should be insulated with a minimum of two inches fiberglass insulation with vapor barrier. It is recommended that flexible connections be used to connect the ductwork to the unit in order to keep the noise transmission to a minimum.

4. FILTER

This unit must not be operated without a filter. It comes equipped with a disposable filter which should be checked often and replaced if dirty. Insufficient air flow due to undersized duct systems or dirty filters can result in nuisance tripping of the high or low pressure controls. Refer to Table 3 for correct air flow and static pressure requirements. See Figure 3.

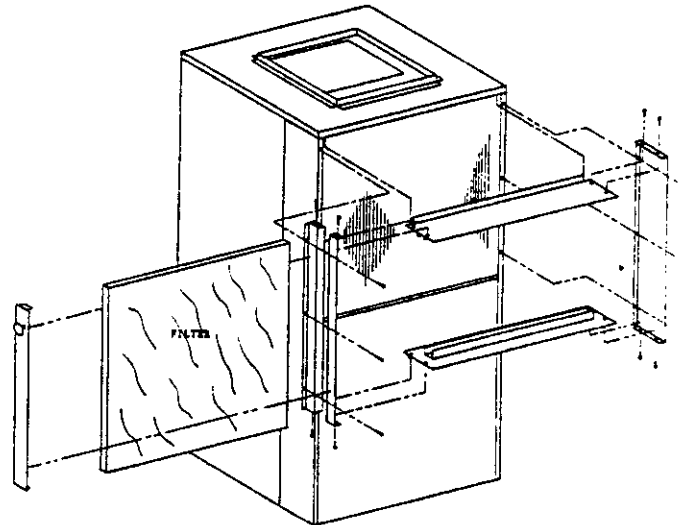

FIGURE 3

5. ELECTRICAL WIRING

All electrical connections are made through the top of the unit. High voltage connections are made with wire nuts to the factory-provided pigtail leads in the junction box. Low voltage connections are made to the terminal strip mounted on the top of the unit. Refer to the wiring diagram for connecting the terminals.

a. MAIN POWER

Refer to the unit serial plate for wire sizing information and correct overcurrent protection size. Each unit is marked with a "Minimum Circuit Ampacity." This means that field wiring connectors must be sized to carry that amount of current. Each unit and/or wiring diagram is also marked "Use Copper Conductors Only," meaning the leads provided are not suitable for aluminum wiring. Refer to The National Electric Code for complete current-carrying capacity data on the various grades of wiring material.

The unit rating plate lists "Maximum Overcurrent Protective Device" that is to be used with the equipment. This device may be a time delay fuse or HACR Type circuit breaker. The correct size overcurrent protective device must be used to provide for proper circuit protection and to avoid nuisance trips due to the momentary high starting current of the compressor motor.

b. CONTROL CIRCUIT—LOW VOLTAGE WIRING

A 24 volt terminal strip is mounted on top of the unit. Two types of thermostats are available: 1) Single stage heat, single stage cool to operate the heat pump alone—without backup duct style electric heaters. This thermostat is equipped with a signal light to indicate when the unit is "locked out" because of the low or high pressure control. Refer to the wiring diagrams at the end of this manual for correct connection of the terminals. 2) Two stage heat, single stage cool to operate the heat pump or duct heaters on heating or the heat pump on cooling. This thermostat is also equipped with a signal light to indicate when the unit is "locked out" because of operation of the low or high pressure control. In addition, a second signal light tells when the unit has been placed in Emergency Heat. Refer to the wiring diagram at the end of this manual and to the wiring diagram packed with the duct heater for correct connection of the low voltage terminals.

6. CONDENSATE DRAIN

Determine where the drain line will run. This drain line contains cold water and must be insulated to avoid droplets of water from condensing on the pipe and dropping on finished floors or the ceiling under the unit. A trap MUST BE installed in the drain line and the trap filled with water prior to start up. The use of plugged tees in place of elbows to facilitate cleaning is highly recommended.

Drain lines must be installed according to local plumbing codes. It is not recommended that any condensate drain line be connected to a sewer main. The drain line enters the unit through the water access panel and connects to the FPT coupling under the condensate drain pan.

7. PIPING ACCESS TO THE UNIT

Water piping to and from the unit enters the unit casing through the water access panel. Piping connections are made directly to the heat exchanger coil and are 3/4" or 1" FPT. The access panel can be installed on any one of three sides (any side of the casing except the air coil side). It is highly recommended that the piping from the water coil to the outside of the casing be installed while the unit is completely accessible and before it is finally set in position.

8. WATER CONNECTIONS

It is very important that an adequate supply of clean, non-corrosive water at the proper pressure be provided before the installation is made. Insufficient water, in the heating mode for example, will cause the low pressure control to trip, shutting down the heat pump. In assessing the capacity of the water system, it is advisable that the complete water system be evaluated to prevent possible lack of water or water pressure at various household fixtures whenever the heat pump turns on. All plumbing to and from the unit is to be installed in accordance with local plumbing codes. The use of plastic pipe, where permissible, is recommended to prevent electrolytic corrosion of the water pipe. Because of the relatively cold temperatures encountered with well water, it is strongly recommended that the water lines connecting the unit be insulated to prevent water droplets from condensing on the pipe surface.

Refer to Piping, Figure 4. Slow closing Solenoid VALVE (6) with a 24V coil provides on/off control of the water flow to the unit. Refer to the wiring diagram for correct hookup of the valve solenoid coil.

Constant Flow Valve (7) provides correct flow of water to the unit regardless of variations in water pressure. Observe the water flow direction indicated by the arrow on the side of the valve body. Following is a table showing which valve is to be installed with which heat pump.

HEAT PUMP MODEL	FLOW RATE	BARD PART NUMBER
WPV30A, WPVD30A	4 GPM	8603-010
WPV36A, WPVD36A	5 GPM	8603-011
WPV53A, WPVD53A	6 GPM	8603-007
WPV62A, WPVD62A	8 GPM	8603-008

Strainer (5) installed upstream of constant flow valve (7) to collect foreign material which would clog the flow valve orifice.

The figure shows the use of shut-off valves (9) and (11), on the in and out water lines to permit isolation of the unit from the plumbing system should future service work require this. Globe valves should not be used as shutoff valves because of the excessive pressure drop inherent in the valve design. Instead use gate or ball valves as shut-offs so as to minimize pressure drop.

Drain cocks (8) and (10), and tees have been included to permit acid cleaning the refrigerant-to-water coil should such cleaning be required. See WATER CORROSION.

Drain Cocks (12) provides access to the system to check water flow through the constant flow valve to insure adequate water flow through the unit. A water meter 1-10 GPM (8603-013) is used to check the water flow rate.

9. WELL PUMP SIZING

Strictly speaking, sizing the well pump is the responsibility of the well drilling contractor. It is important, however, that the HVAC contractor be familiar with the factors that determine what size pump will be required. Rule of thumb estimates will invariably lead to under or oversized well pumps. Undersizing the pump will result in inadequate water to the whole plumbing system but with especially bad results to the heat pump—NO HEAT/NO COOL calls will result. Oversized pumps will short cycle and could cause premature pump motor or switch failure.

The well pump must be capable of supplying enough water and at an adequate pressure to meet competing demands of water fixtures. The well pump must be sized in such a way that three requirements are met:

1. Adequate flow rate in GPM.
2. Adequate pressure at the fixture.
3. Able to meet the above from the depth of the well-feet of lift.

The pressure requirements put on the pump are directly affected by the diameter of pipe being used as well as by the water flow rate through the pipe. The worksheet included in Manual 2100-078 should guarantee that the well pump has enough capacity. It should also ensure that the piping is not undersized which would create too much pressure due to friction loss. High pressure losses due to undersized pipe will reduce efficiency and require larger pumps and could also create water noise problems.

SEQUENCE OF OPERATION

1. COOLING WITH OR WITHOUT DUCT HEATERS

Whenever the system lever is moved to COOL, thermostat system switch completes a circuit R to O, energizing the reversing valve solenoid. On a call for cooling, the cooling bulb completes a circuit from R to G, energizing the blower relay coil. The blower relay contacts complete a 230 volt circuit to the blower motor and the blower operates. R to Y circuit is completed at the same time as the fan circuit and current flows from Y to terminal 4 at the lockout relay. Terminal 4 of the lockout relay provides two paths for current flow.

NOTE:

- ① On models approved for closed loop installations (WPVxxA and WPDxxA), low pressure switch is replaced with an adjustable thermostat. This thermostat is factory installed with capillary wrapped around refrigerant line and factory set to 10°F.

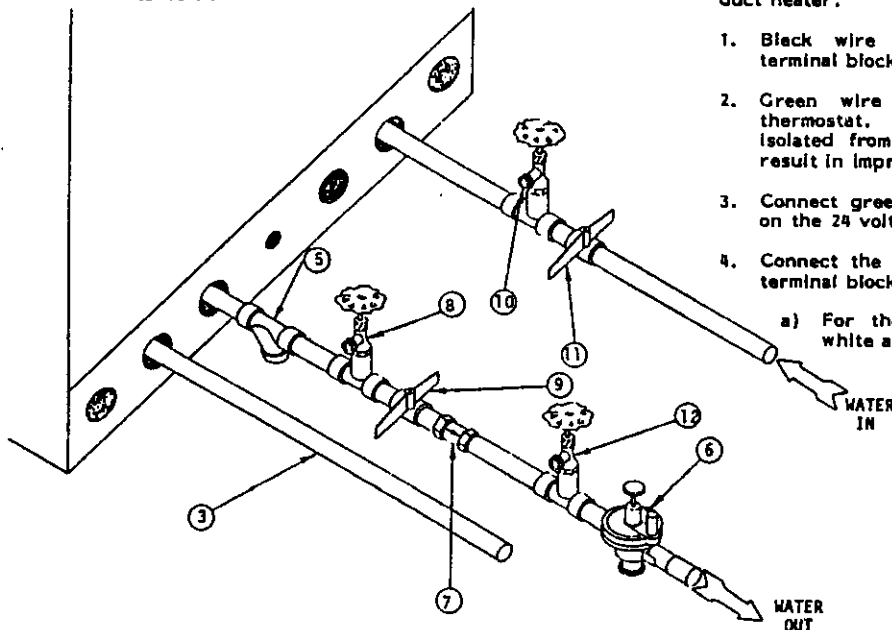

FIGURE 4

1. Through the lockout relay coil which offers the resistance of the lockout relay coil.
2. Through the normally closed contacts of the lockout relay to terminal 5 of the lockout relay and then through the high and low pressure switches to the compressor contactor coil.

If the high and low pressure switches remain closed (refrigerant pressure remains normal), the path of least resistance is through these safety controls to the compressor contactor coil. The contacts of the compressor contactor complete a 230 volt circuit to the compressor and the compressor runs. If discharge (suction) pressure reaches the set point of the high (low) pressure control, the normally closed contacts of the high (low) pressure control open and current no longer flows to the compressor contactor coil—the coil drops out. Current now can take the path of least resistance through the lockout relay coil, energizing the lockout relay coil and opening terminals 4 and 5 of the lockout relay. The lockout relay will remain energized as long as a circuit is completed between R and Y at the thermostat. In the meantime, since the compressor is not operating, refrigerant pressure will equalize and the high (low) pressure switch will automatically reset. However, the circuit to the compressor contactor will not be complete until the lockout relay is de-energized by moving the thermostat system switch to OFF, breaking the circuit from R to Y, dropping out the lockout relay coil and permitting terminals 4 and 5 to make. When the high (low) pressure switch closes, a circuit is completed to L at the thermostat, energizing the signal light to indicate a malfunction. When the system switch is moved from OFF to COOL, the cycle is repeated.

2. SINGLE STAGE HEAT WITHOUT DUCT HEATERS

Compressor circuit R to Y including lockout relay and pressure controls is the same as cooling. Blower circuit R to G is the same as cooling. With system switch set to HEAT, no circuit is completed between R and O and reversing valve solenoid is not energized.

3. TWO STAGE HEAT WITH DUCT HEATERS

First stage heat is the same as single stage heating without duct heater. When the second stage thermostat bulb makes, a circuit is completed from C to W2 and W3, energizing the duct heater heat contactor, through the heating element and manual reset limit. C to W2 also simultaneously energizes the 24 volt coil on the interlock relay, closing the contacts, which in turn energize the low voltage coil on the blower relay to close the high voltage contacts and power the blower motor. The elements and blower remain energized as long as C to W2 are made.

The following is a verbal description of the proper procedure for connecting the low voltage hookups for the duct heater.

1. Black wire from duct heater to C on the 24 volt terminal block.
 2. Green wire from duct heater to green wire from thermostat. These wires must be wire nipped and isolated from the terminal block. Failure to do so will result in improper heater operation.
 3. Connect green with tracer from heater to the G terminal on the 24 volt terminal block.
 4. Connect the white wire from the heater to W2 on 24 volt terminal block.
- a) For the 15 and 20kw duct heaters, connect the white and white with black tracer wires to W2.

4. EMERGENCY HEAT

When the system switch is moved to EMER, the compressor circuit R to Y is disconnected. Control of the electric heaters is from C to W2 through the thermostat second stage heating bulb. Blower operation is controlled by the second stage heating bulb. Operation is the same as above, "Two Stage Heat With Duct Heaters."

SYSTEM START UP PROCEDURE

1. Be sure main power to the unit is OFF at the disconnect.
 2. Set thermostat system switch to OFF, fan switch to AUTO.
 3. Move main power disconnect to ON. Power should be on to unit for a minimum of four hours or sixty minutes per pound of refrigerant. This allows the crankcase heater to drive any refrigerant liquid out of the compressor sump. This procedure should be followed whenever the power has been off for twelve hours or longer. Except as required for safety while servicing—DO NOT OPEN THE UNIT DISCONNECT SWITCH.
 4. Check system air flow for obstructions.
 - a) Move thermostat fan switch to ON. Blower runs.
 - b) Be sure all registers and grilles are open.
 - c) Move thermostat fan switch to AUTO. Blower should stop.
 5. Fully open the manual inlet and outlet valves.
 6. Check water flow. (See Photo 1)
 - a) Connect a water flow meter to the drain cock (12, Fig. 4) between the constant flow valve and the solenoid valve. Run a hose from the flow meter to a drain or sink. Open the drain cock.
 - b) Check the water flow rate through constant flow valve to be sure it is the same as the unit is rated for.
(Example: 4 GPM for a WPV30)
 - c) When water flow is okay, close drain cock and remove the water flow meter. The unit is now ready to start.
 7. Start the unit in cooling mode. \triangle By moving the thermostat switch to cool, fan should be set for AUTO.
 - a) Check to see the solenoid valve opened.
 8. Check the system refrigerant pressures against the cooling refrigerant pressure curve in the Installation Manual for rated water flow and entering water temperatures. If the refrigerant pressures do not match, check for air flow problem then refrigeration system problem.
 9. Switch the unit to the heating mode. \triangle By moving the thermostat switch to heat, fan should be set for AUTO.
 - a) Check to see the solenoid valve opened again.
 10. Check the refrigerant system pressures against the heating refrigerant pressure curve in Installation Manual. Once again, if they do not match, check for air flow problems and then refrigeration system problems.
- NOTE: If a charge problem is determined (high or low):
- a) Check for possible refrigerant leaks.
 - b) Discharge all remaining refrigerant from unit.
 - c) Evacuate unit down to 29 inches of vacuum.
 - d) Recharge the unit with refrigerant by weight. This is the only way to insure a proper charge in cap tube system.

\triangle For models with domestic hot water heat exchanger, be sure the water pump switch is off while checking refrigerant system.

UNIT WITH HEAT RECOVERY FOR HEATING
DOMESTIC HOT WATER -- WPVD SERIES

GENERAL

Units having a heat recovery coil should only be installed by trained refrigeration technicians. These instructions serve as a guide to the technician installing the heat recovery portion of the unit. They are not intended as a step-by-step procedure with which the mechanically inclined owner can install the unit.

DESCRIPTION

Units with the heat recovery coil mounted at the factory are designed to recover the "waste" heat from the compressor discharge gas and use this "waste" heat to heat domestic hot water. Units so equipped may be identified by the letter "D" in the model number. In addition to the components already described for the heat pump, these units are equipped with an additional water-to-refrigerant coil, a circulating pump and a thermostat to control the operation of the circulating pump. The water-to-refrigerant coil is constructed of two tubes. Water flows through the center tube, refrigerant flows through a surrounding tube, totally separated from the water tube. The space between these two tubes is vented to atmosphere. In the unlikely event a leak should develop, no leakage can occur between the water and the refrigerant.

INSTALLATION

1. TWO TANK. In order to realize the maximum energy savings from the domestic hot water heat recovery unit, it is recommended that a second water storage tank be installed in addition to the main hot water heater. Fossil fuel fired water heaters must be a two tank installation. If the existing water heater is electric, the two tank installation is still the best approach, however, a one tank installation is satisfactory. Tanks specifically intended for hot water storage are available from water heater manufacturers (solar hot water storage tanks). These tanks have special dip tube arrangements, are built without heaters and are constructed with heavier insulation. However, a well insulated electric water heater without the electric heating elements connected will also make a suitable storage tank.

The size of this tank should be as large as space and economy permit but in no event should it be less than one-half of the daily water requirements for the occupants. As a guide in estimating the daily family water requirements, the Department of Energy recommends a figure of 16.07 gallons of hot water per day per individual. For example, a family of four would require 64.3 gallons per day (4 x 16.07).

2. ONE TANK. Where space or first cost economy dictates only one hot water heater, a single tank installation is permissible. It should be noted, however, that the amount of savings realized is reduced.

The single hot water tank may be a new hot water heater (sized in this case to 100% of daily water requirements) or the existing water heater in the case of a retrofit installation. The existing hot water heater should be carefully inspected and any sediment removed by draining the water heater and flushing it until all loose sediment has been flushed away. This sediment, besides cutting down on the efficiency of the water heater and heat recovery unit, could damage the circulating pump, or clog the strainer and stop water flow.

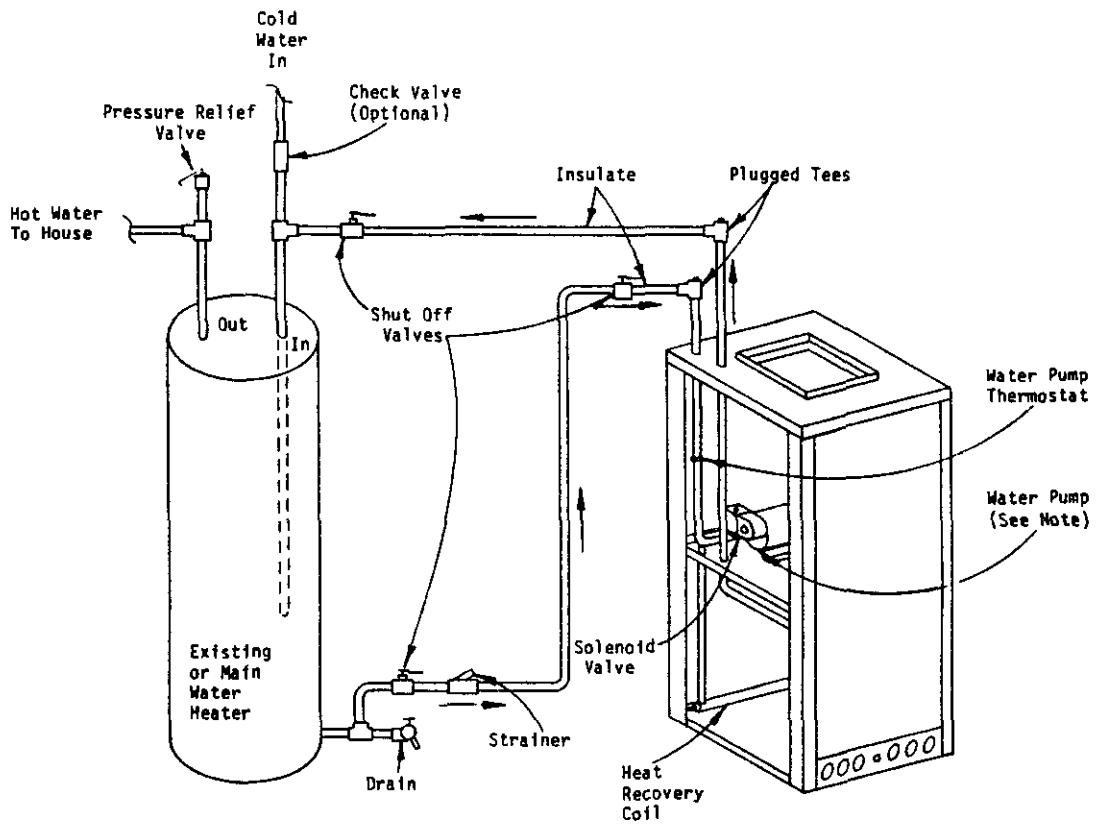

NOTE: DO NOT OPERATE WATER PUMP WITHOUT WATER LINES CONNECTED AND WATER IN SYSTEM WITH SHUT OFF VALVES OPEN! TURN PUMP SWITCH TO OFF.

TYPICAL "WPVD" MODEL ONE TANK INSTALLATION (Permissible)

FIGURE 5

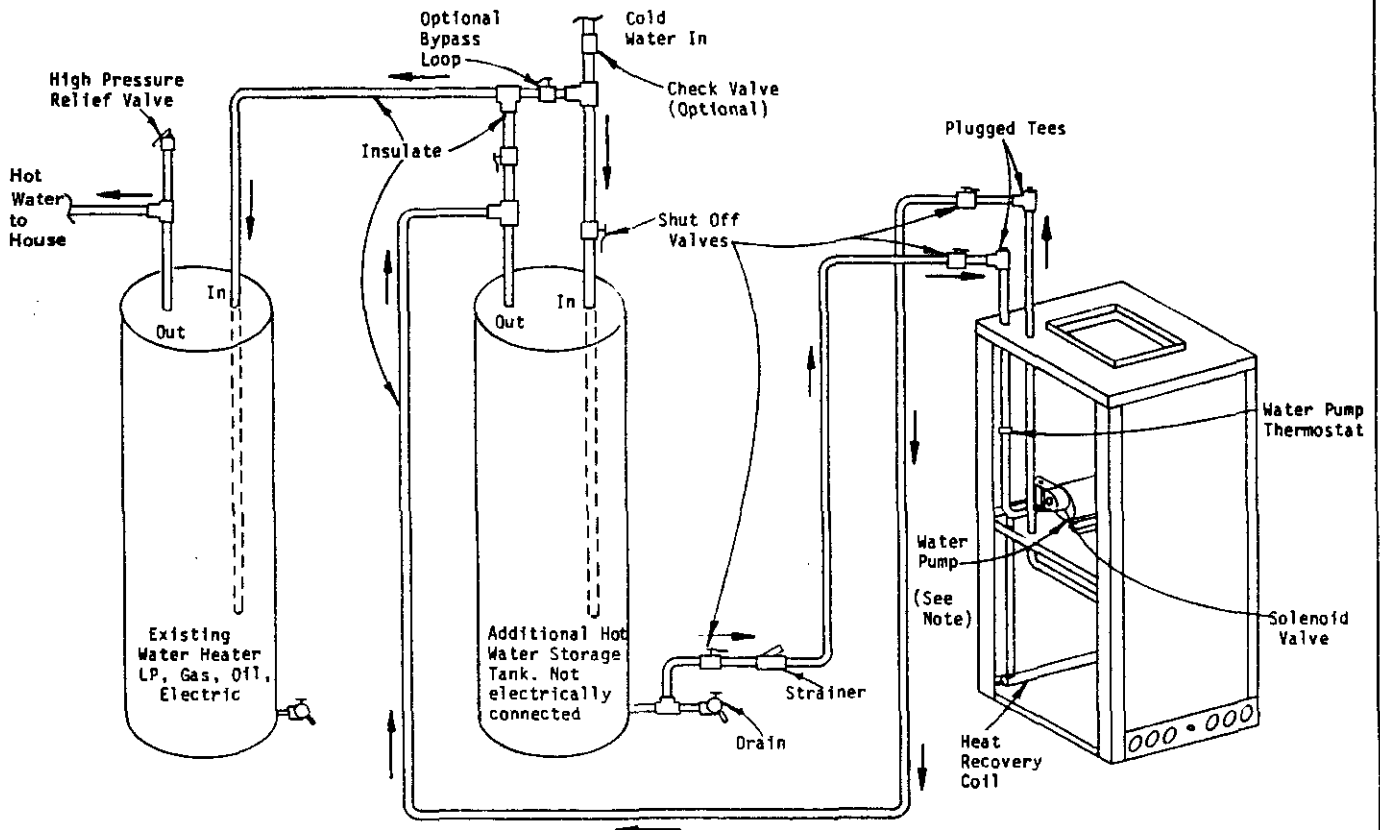

NOTE: DO NOT OPERATE WATER PUMP WITHOUT WATER LINES CONNECTED AND WATER IN SYSTEM WITH SHUT OFF VALVES OPEN! TURN PUMP SWITCH TO OFF.

TYPICAL "WPVD" MODEL TWO TANK INSTALLATION (Preferred)

FIGURE 6

LOCATION

In determining the location of the storage tank (and the water heater) keep in mind that small temperature differences between the storage tank water temperature and the refrigerant temperature permit this unit to function. It is consequently necessary that all tubing be kept as short and direct as possible and that the tubing be adequately and thoroughly insulated.

Locate the storage tank as close to the heat pump and water heater as the installation permits. Be sure to provide adequate service access to all components.

INSTALLATION PROCEDURE - GENERAL

1. Turn off the water heater electric power (if electric hot water heater) or close the fuel supply line (if fossil fuel water heater).
2. Turn off the electric power to the water source heat pump.
3. Shut off the main water supply line by closing the water valve at the well pressure tank (if a well system) or the water meter (if city water is being used for domestic purposes).
4. Connect a garden hose to the water heater drain valve (bottom of the water heater tank) and drain the water heater to a floor drain or other convenient drain.
5. If the water heater has been in service for some time, inspect it for sediment. Remove all sediment and thoroughly flush the water heater tank.

WATER PIPING

Two tank installation, refer to Piping Diagram, Fig. 6 and steps 1 to 3, and Two Tank installation instructions. One tank installation, refer to Piping Diagram, Fig. 7 and steps 1 to 3 and One Tank installation instructions. Follow all local plumbing codes. Piping connections are 1/2 inch O.D. copper pipe, Type K or L, and are made inside the unit. Route the copper through the top of the heat pump through the holes provided.

1. A plugged tee and shut off valve should be provided near the heat pump unit. This will make it easy if it ever becomes necessary to clean the desuperheater coil. A suitable cleaner is mentioned below, "Water Corrosion" section. The shut off valves will isolate the unit from the rest of the plumbing and the plugged tees will provide access to the coil and pump for the cleaner.
2. A strainer is included in both figures to collect any sediment which may accumulate in the storage tank or water heater. This strainer should be of the cleanable "Y" type. It is more important that the strainer be included on one tank retrofit installation where the hot water heater may be suspected of sedimentation.
3. A check valve is shown in both figures as an option. The purpose of the check valve is to prevent any contamination of the water system in the unlikely event that the heat exchanger develops a leak. Check the local plumbing code as this check valve may be required.

TWO TANK INSTALLATION - FIGURE 6

1. Water into the heat recovery unit is taken from the bottom of the storage tank. This location will insure that the coldest water will always be circulated to the recovery unit.
2. If a solar type water storage tank is being used (specifically designed for storing but not heating water), insert the dip tubes according to the manufacturer's instructions.
3. If a second water heater is being used for storage, install a pipe thread tee and a suitably sized pipe nipple in the water heater drain connection (bottom of the tank). The run of the tee is connected between the water heater and a drain valve. Brass or bronze fittings are recommended

for these fittings. Check the local plumbing code—brass or bronze may be required. The branch of the tee is connected to the recovery unit "water in" copper tube. Use a pipe thread to sweat adapter to connect the tubing between the tee and recovery unit.

4. The "water out" tubing from the recovery unit is connected through a tee to the storage tank and to the normal "water in" of the main water heater.

5. Cold water into the storage tank is connected to the "water in" of the storage tank.

6. An optional bypass loop with valve is shown in Fig. 6 between the water into the storage tank and the "water out" of the storage tank. The loop will make future service work easier should it become necessary to drain the storage tank. In normal operation the valve in the bypass loop should be closed.

ONE TANK INSTALLATION — FIGURE 5

NOT RECOMMENDED FOR FOSSIL FUEL FIRED WATER HEATER

1. Unless the single hot water heater is new, it should be thoroughly inspected and cleaned of sediment. Flush the tank several times and inspect it after each flushing. Be sure the tank is free of sedimentation.
2. Water from the hot water heater is connected to the domestic hot water supply as any conventional hot water heater would be connected.
3. Water to the heat recovery unit is connected through a tee at the drain valve connection of the hot water heater as described in step 3 above.
4. Water from the recovery unit is connected at the "water in" connection of the hot water heater through a tee.

OPERATION OF THE HEAT RECOVERY UNIT

The circulating pump and solenoid valve are wired in parallel with the heat pump compressor (230 VAC circuit). Thus, no water can be circulated to the water-to-refrigerant coil unless the compressor is in operation.

In addition, a thermostat, attached to the entering water tube of the pump, is wired in series with the pump motor and solenoid valve. The thermostat is normally closed and opens when the tube temperature reaches 150°F. This will stop further heating of the water by the recovery unit and is intended to prevent overheating the water. The thermostat will reset at approximately 120°F.

Heat for domestic hot water is obtained from the discharge gas of the compressor. This heat would ordinarily be rejected to the ground water in the cooling mode or to the room air in the heating mode. With the recovery unit this heat is transferred to the storage tank or water heater.

START UP AND CHECK OUT

1. Be sure all shut off valves are open. If optional bypass valve, see Fig. 6, has been installed, this valve should be closed.
2. Open a hot water faucet to permit any air to bleed from the plumbing.
3. Turn off the heat pump disconnect.
4. Temporarily remove compressor wire from load side of contactor and insulate.
5. Turn heat pump disconnect ON.
6. Set the wall thermostat to cool.
7. Inspect for water leaks and verify pump is operating.
8. Again turn off the heat pump disconnect.
9. Re-install compressor wire on compressor contactor terminal.

START UP AND CHECK OUT (Cont)

10. Repeat steps 5 and 6. Feel the "water in" and "water out" tubes. There should be a noticeable temperature difference. How much temperature difference you measure will depend upon tubing length, flow rate, storage tank temperature and could vary from 2°F to 20°F.

11. Move thermostat system to OFF. Verify that water pump stops.

WATER CORROSION

Two concerns will immediately come to light when considering a water source heat pump, whether for ground water or for a closed loop application: Will there be enough water? And, how will the water quality affect the system?

Water quantity is an important consideration and one which is easily determined. The well driller must perform a pump down test on the well according to methods described by the National Well Water Association. This test, if performed correctly, will provide information on the rate of flow and on the capacity of the well. It is important to consider the overall capacity of the well when thinking about a water source heat pump because the heat pump may be required to run for extended periods of time.

The second concern, about water quality, is equally important. Generally speaking, if the water is not offensive for drinking purposes, it should pose no problem for the heat pump. The well driller or local water softening company can perform tests which will determine the chemical properties of the well water.

Water quality problems will show up in the heat pump in one or more of the following ways:

1. Decrease in water flow through the unit.
2. Decreased heat transfer of the water coil (entering to leaving water temperature difference is less).

There are four main water quality problems associated with ground water. These are:

- (1) Biological growth. This is the growth of microscopic organisms in the water and will show up as a slimy deposit throughout the water system. Shock treatment of the well is usually required and this is best left up to the well driller. The treatment consists of injecting chlorine into the well casing and flushing the system until all growth is removed.
- (2) Suspended particles in the water. Filtering will usually remove most suspended particles (fine sand, small gravel) from the water. The problem with suspended particles in the water is that it will erode metal parts, pumps, heat transfer coils, etc. So long as the filter is cleaned and periodically maintained, suspended particles should pose no serious problem. Consult with your well driller.
- (3) Corrosion of metal. Corrosion of metal parts results from either highly corrosive water (acid water, generally not the case with ground water) or galvanic reaction between dissimilar metals in the presence of water. By using plastic plumbing or di-electric unions galvanic reaction is eliminated. The use of corrosion resistant materials (such as the Cupro Nickel coil) throughout the water system will reduce corrosion problems significantly.
- (4) Scale formation. Of all the water problems, the formation of scale by ground water is by far the most common. Usually this scale is due to the formation of calcium carbonate but magnesium carbonate or calcium sulfate may also be present. Carbon dioxide gas (CO₂), the carbonate of calcium and magnesium carbonate, is very soluble in water. It will remain dissolved in the water until some outside factor upsets the balance. This outside influence may be a large change in water temperature or pressure. When this happens, enough carbon dioxide gas combines with dissolved calcium or magnesium in the water and falls out of solution until a new balance is reached. The change in temperature that

this heat pump produces is usually not high enough to cause the dissolved gas to fall out of solution. Likewise if pressure drops are kept to a reasonable level, no precipitation of carbon dioxide should occur.

REMEDIES OF WATER PROBLEMS

WATER TREATMENT. Water treatment can usually be economically justified for closed loop systems. However, because of the large amounts of water involved with a ground water heat pump, water treatment is generally too expensive.

ACID CLEANING THE WATER COIL OR HEAT RECOVERY UNIT. If scaling of the coil is strongly suspected, the coil can be cleaned up with a solution of Phosphoric Acid (food grade acid). Follow the manufacturer's directions for mixing, use, etc. Refer to the "Cleaning Water Coil", Fig. 7. The acid solution can be introduced into the heat pump coil through the hose bib (Part 8 of Fig. 7). Be sure the isolation valves (Parts 9 and 11 of Fig. 7) are closed to prevent contamination of the rest of the system by the coil. The acid should be pumped from a bucket into the hose bib (Part 8, Fig. 7) and returned to the bucket through the other hose bib (Part 10, Fig. 7). Follow the manufacturer's directions for the product used as to how long the solution is to be circulated, but it is usually circulated for a period of several hours.

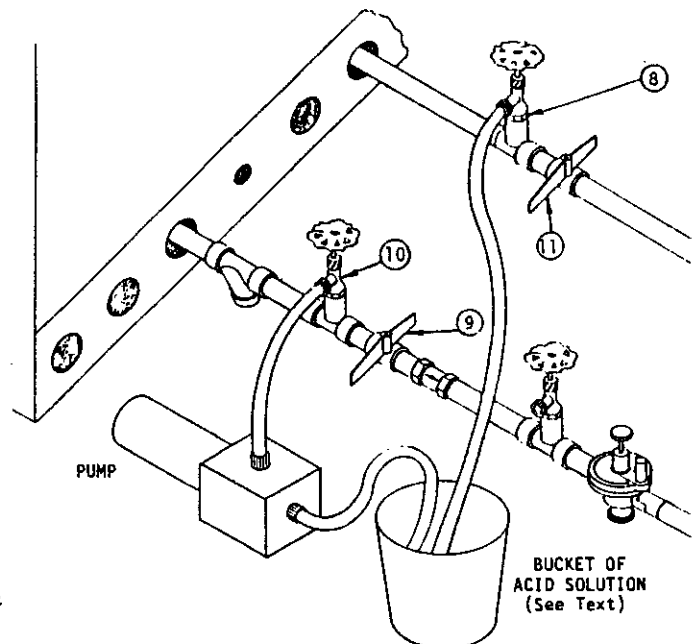

FIGURE 7

LAKE AND POND INSTALLATIONS

Lakes and ponds can provide a low cost source of water for heating and cooling with a ground water heat pump. Direct usage of the water without some filtration is not recommended as algae and turbid water can foul the water to freon heat exchanger. Instead, there have been very good results using a dry well dug next to the water line or edge. Normal procedure in installing a dry well is to backhoe a 15 to 20 foot hole adjacent to the body of water (set backhoe as close to the water's edge as possible). Once excavated, a perforated plastic casing should be installed with gravel backfill placed around the casing. The gravel bed should provide adequate filtration of the water to allow good performance of the ground water heat pump.

The following is a list of recommendations to follow when installing this type of system:

- A lake or pond should be at least 1 acre (40,000 sq. ft.) in surface area for each 50,000 BTUs of ground water heat pump capacity or have two times the cubic feet size of the dwelling that you are trying to heat (includes basement if heated).
- The average water depth should be at least 5 feet and there should be an area where the water depth is at least 12 to 15 feet deep.
- If possible, use a submersible pump suspended in the dry well casing. Jet pumps and other types of suction pumps normally consume more electrical energy than similarly sized submersible pumps. Pipe the unit the same as a water well system.
- Size the pump to provide necessary GPM for the ground water heat pump. A 12 GPM or greater water flow rate is required on all modes when used on this type system.
- A pressure tank should be installed in the dwelling to be heated adjacent to the ground water heat pump. A pressure switch should be installed at the tank for pump control.
- All plumbing should be carefully sized to compensate for friction losses, etc., particularly if the pond or lake is over 200 feet from the dwelling to be heated or cooled.
- Keep all water lines below low water level and below the frost line.
- Most installers use 4-inch field tile (rigid plastic or corrugated) for water return to the lake or pond.
- The drain line discharge should be located at least 100 feet from the dry well location.

- The drain line should be installed with a slope of 2 inches per 10 feet of run to provide complete drainage of the line when the ground water heat pump is not operating. This gradient should also help prevent freezing of the discharge where the pipe terminates above the frost line.
- Locate the discharge high enough above high water level so the water will not back up and freeze inside the drain pipe.
- Where the local conditions prevent the use of a gravity drainage system to a lake or pond, you can instead run standard plastic piping out into the pond below the frost and low water level.

WARNING: THIN ICE MAY RESULT IN THE VICINITY OF THE DISCHARGE LINE.

WARNING: Many ground water heat pumps are designed to operate only at water temperatures of 45°F or higher. Water temperatures at the bottom of an ice covered pond can drop down close to freezing (38°F), which is too cold for some units to operate. Those ground water heat pumps designed for low water temperature operation normally are sent out from the manufacturer with a low pressure control set at between 28 and 35 PSIG. BE SURE THAT THE UNIT HAS LOW TEMPERATURE PERFORMANCE DOWN TO 35 DEGREES, THAT CAN OPERATE SAFELY WITHOUT ANTIFREEZE.

For complete information on water well systems and lake and pond applications, refer to Manual 2100-078B (or later edition), available from your distributor.

EARTH COUPLED GROUND LOOP APPLICATIONS

This unit is also designed to work on earth coupled ground loop system, however, these systems operate at entering water (without antifreeze) temperature well below the temperature normally experienced in water well system. A SPST thermostat senses refrigerant temperature and shuts off compressor should extremely low antifreeze temperatures or loss of flow occur. Factory set at 10°F.

For information on earth coupled loop design, piping connections to heat pump and installation refer to Manual 2100-099, "Earth Coupled Loop System Design Manual," available from your distributor.

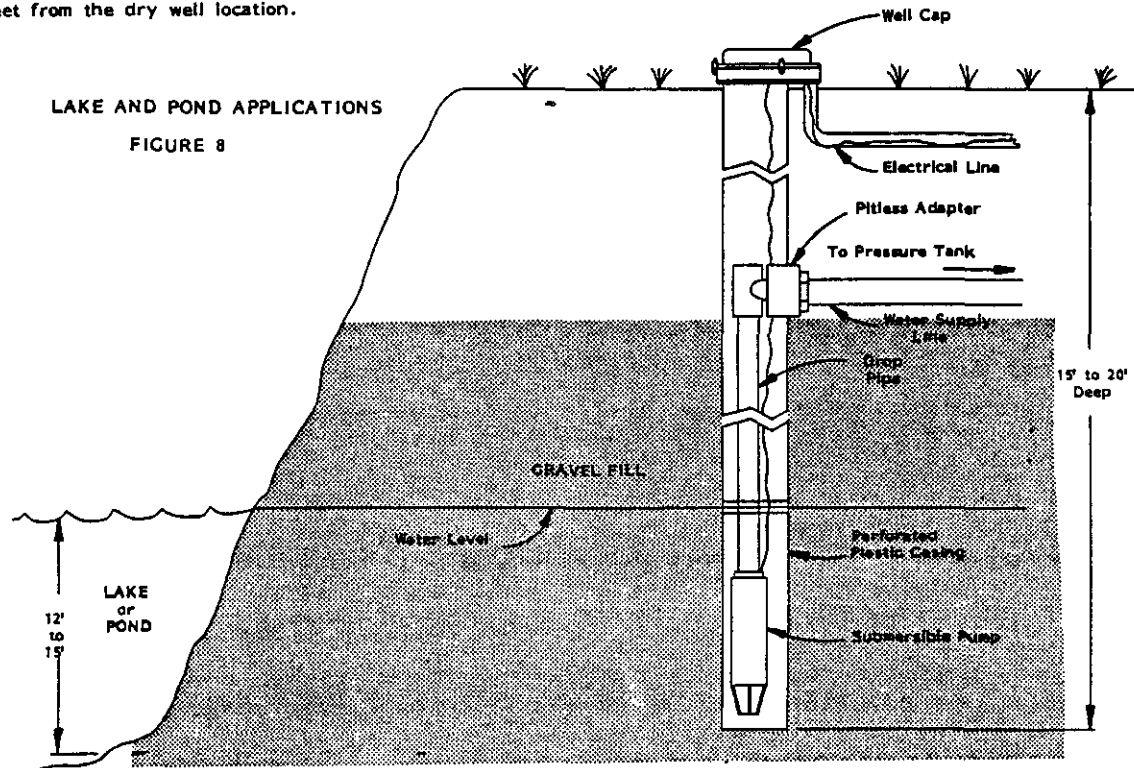

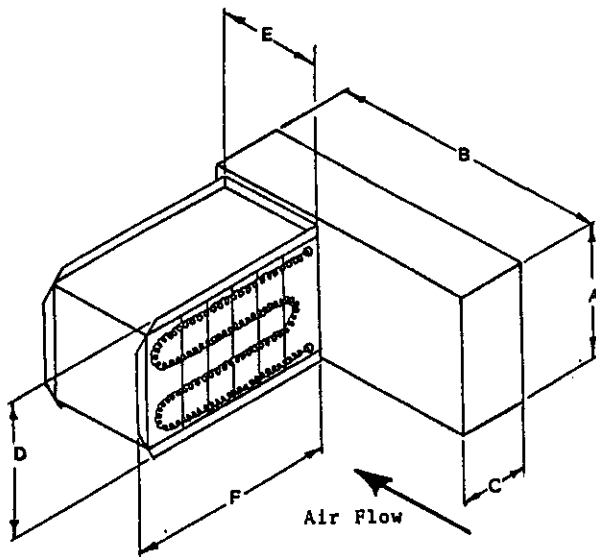

TABLE 5				
WATER COIL PRESSURE DROP				
MODEL	WPV30A WPVD30A	WPV36A WPVD36A	WPV53A WPVD53A	WPV62A WPVD62A
GPM	PSIG	PSIG	PSIG	PSIG
4	2.0	1.9	--	--
5	3.0	2.0	--	--
6	4.2	2.4	2.5	2.5
7	5.7	3.0	3.2	3.5
8	7.5	3.9	4.0	4.5
9	9.5	5.5	5.2	5.6
10	12.0	7.6	6.5	6.7
11	14.8	10.4	7.7	8.0
12	17.6	15.3	9.0	9.3
13	20.3	20.6	10.5	10.7
14	--	--	12.0	12.3
15	--	--	13.9	15.5
16	--	--	15.8	18.3

TABLE 1													
ACCESSORY ITEMS — DUCT HEATER													
PART NO.	PH	VOLTS	KW	MINIMUM AMPACITY	WIRE SIZE ^Δ		MAX. FUSE	DIMENSIONS					
					Cu	Al		A	B	C	D	E	F
8604-080	1	240	5	27	#10	#8	30	8	10	4	7	7	12
8604-081	1	240	9.8	52	#6	#4	55	8	10	4	7	7	16
8604-082 ^Δ	1	240	14.7	78	#4	#1	80	15	18	4	11	9	18
8604-083 ^Δ	1	240	19.2	100	#2	#0	100	15	18	4	11	9	18

^Δ Use wire suitable for at least 75°C.
^Δ Fused units (over 48 amperes).

TABLE 6	
WATER COIL RATED FLOW	
MODEL	GPM
WPV30A WPVD30A	4
WPV36A WPVD36A	5
WPV53A WPVD53A	6
WPV62A WPVD62A	8

TABLE 2								
INDOOR BLOWER PERFORMANCE								
CFM — DRY COIL WITH FILTER								
MODEL	WPV30A, WPVD30A WPV36A, WPVD36A			WPV53A, WPVD53A WPV62A, WPVD62A With Optional CW45 Installed			WPV53A, WPVD53A WPV62A, WPVD62A Without Optional CW45 Installed	
	E.S.P. IN. W.C.	High	Medium	Low	High	Medium	Low	High
0	1400	1270	1210	1920	1780	1600	1920	1750
.10	1345	1230	1170	1880	1750	1580	1880	1710
.20	1280	1180	1130	1830	1720	1550	1830	1670
.30	1210	1110	1090	1810	1680	1540	1750	1630
.40	1130	1070	1040	1750	1630	1500	1700	1570
.50	1050	1000	980	1650	1570	1440	1610	1520
.60	970	890	900	1580	1500	1400	1550	1450

TABLE 3		
MODEL	RATED CFM	RECOMMENDED AIR FLOW RANGE—CFM
WPV30A WPVD30A	1000	900 - 1090
WPV36A WPVD36A	1200	1070 - 1345
WPV53A WPVD53A	1550	1400 - 1700
WPV62A WPVD62A	1700	1530 - 1830

TABLE 4		
PART NO.	MIN. AVAILABLE PRESSURE PSIG	FLOW RATE GPM
8603-007	15 ^Δ	6
8603-008	15 ^Δ	8
8603-010	15 ^Δ	4
8603-011	15 ^Δ	5

^Δ The pressure drop through the constant flow valve will vary depending on the available pressure ahead of the valve. Unless a minimum of 15 psig is available immediately ahead of the valve no water will flow.

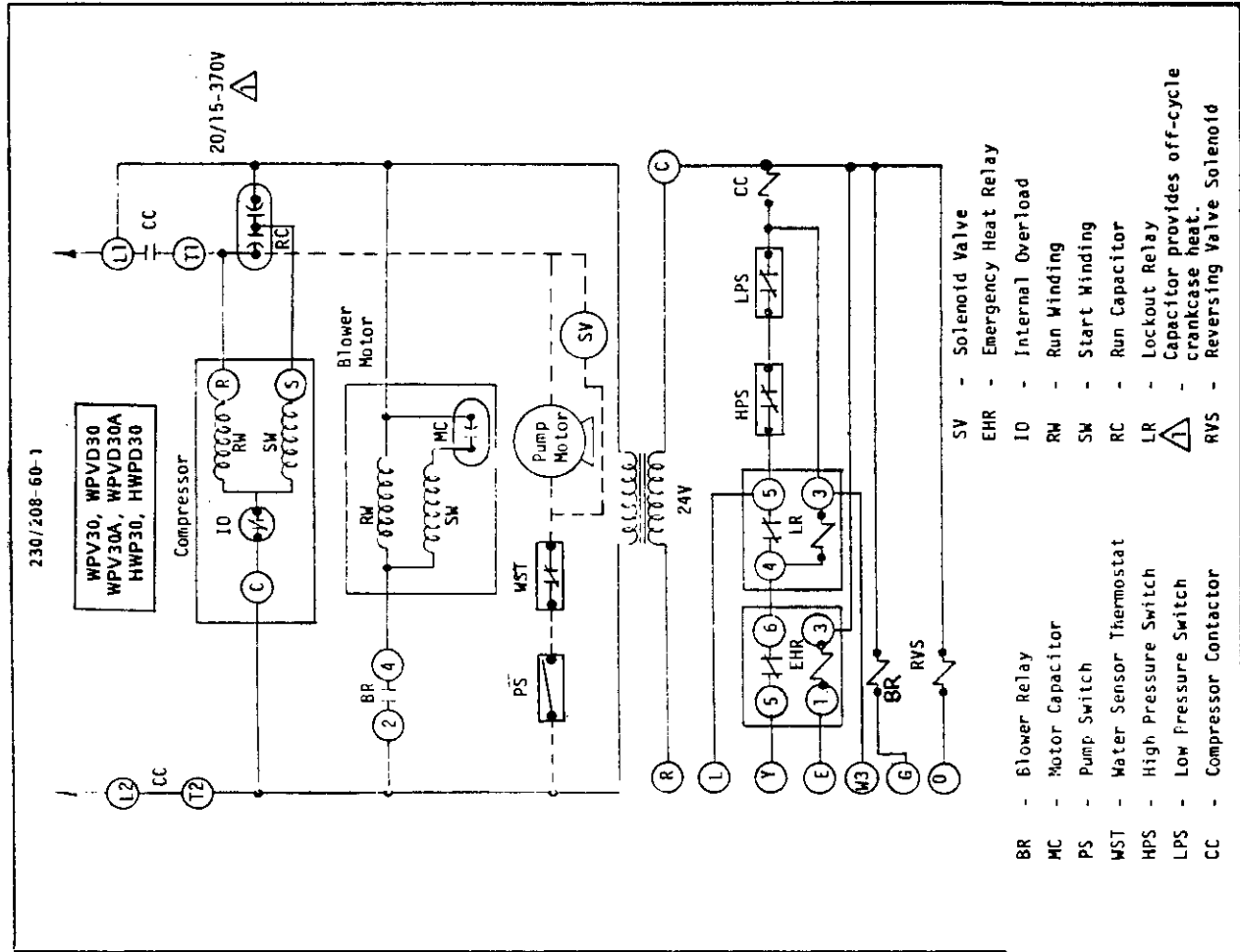

4049-800C

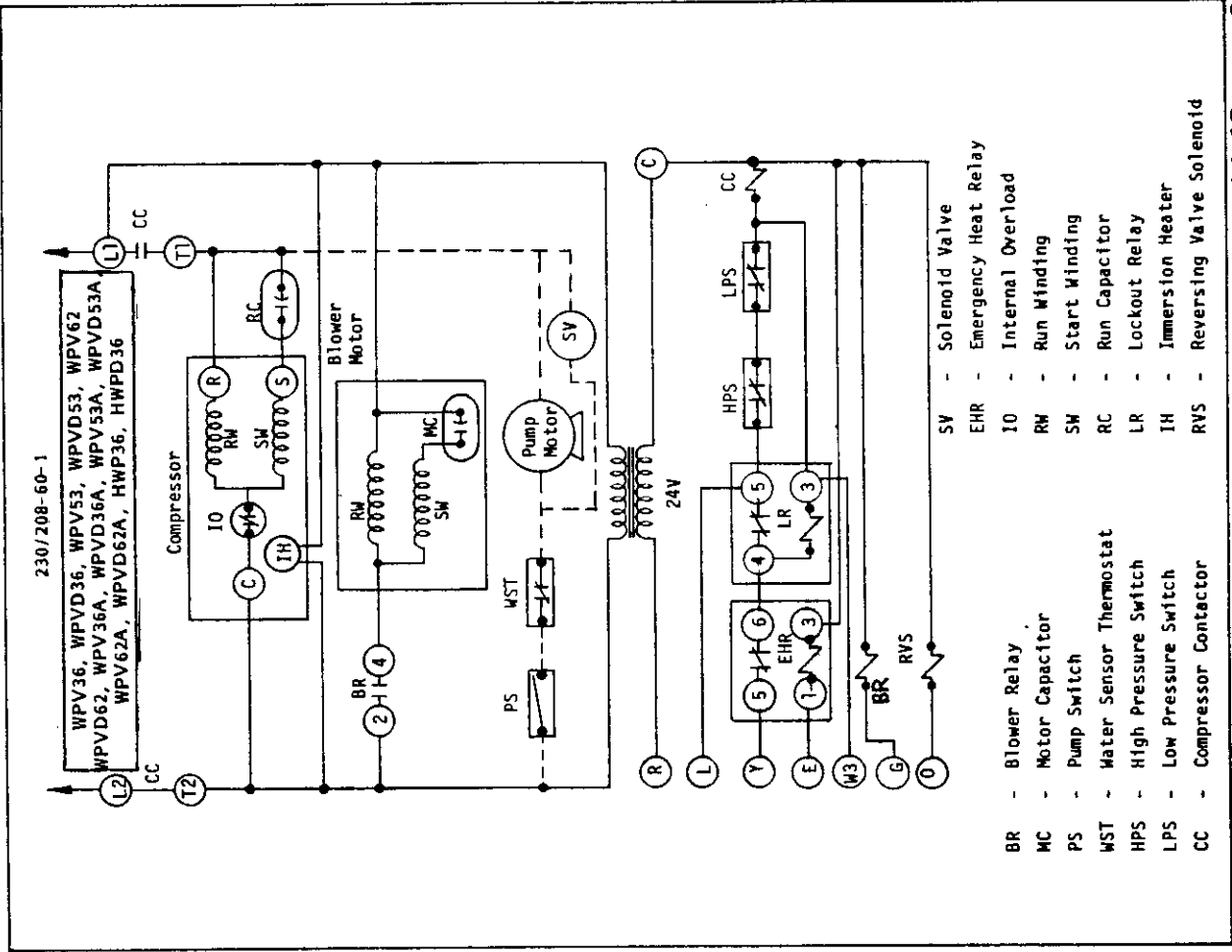

4049-801C

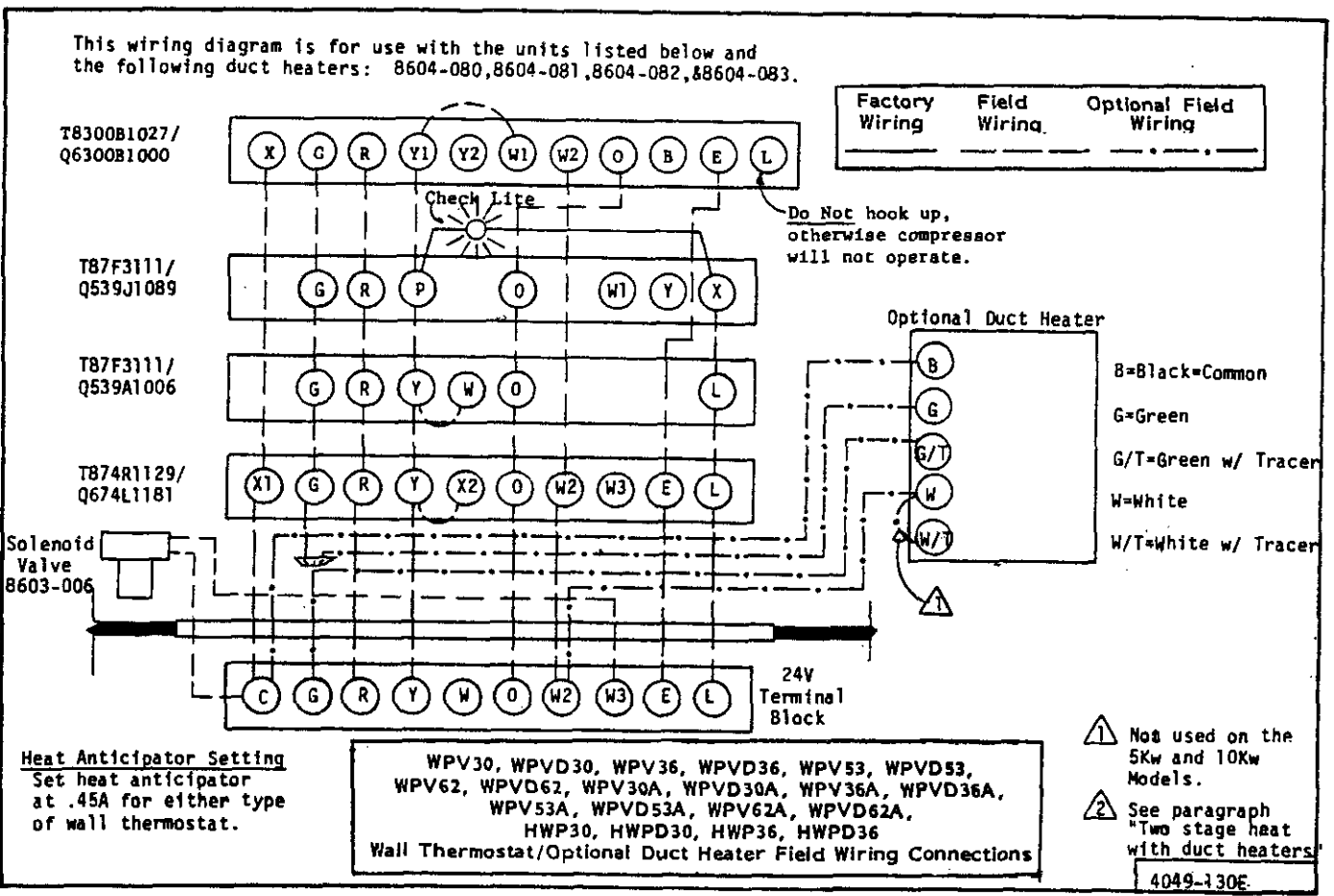
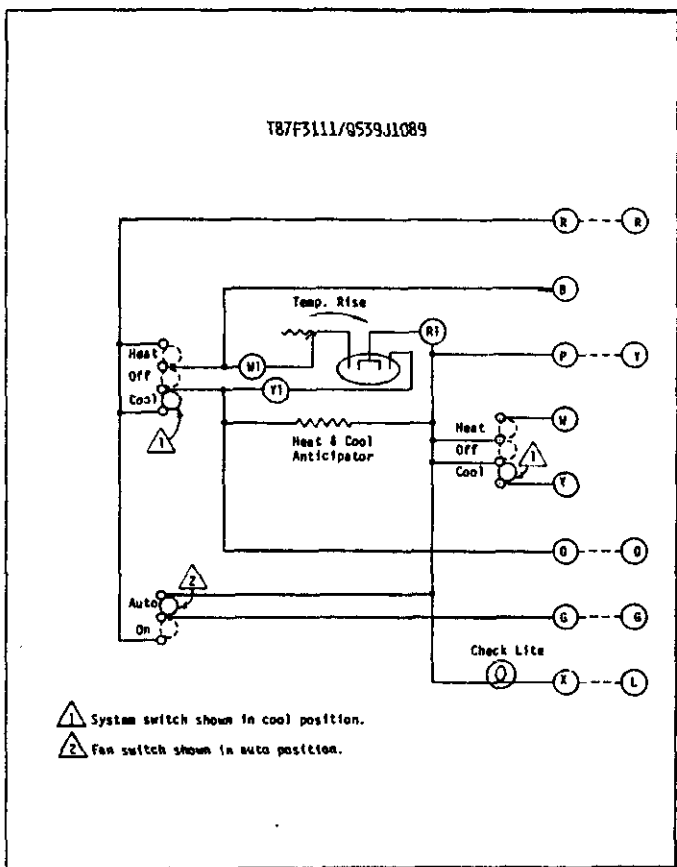
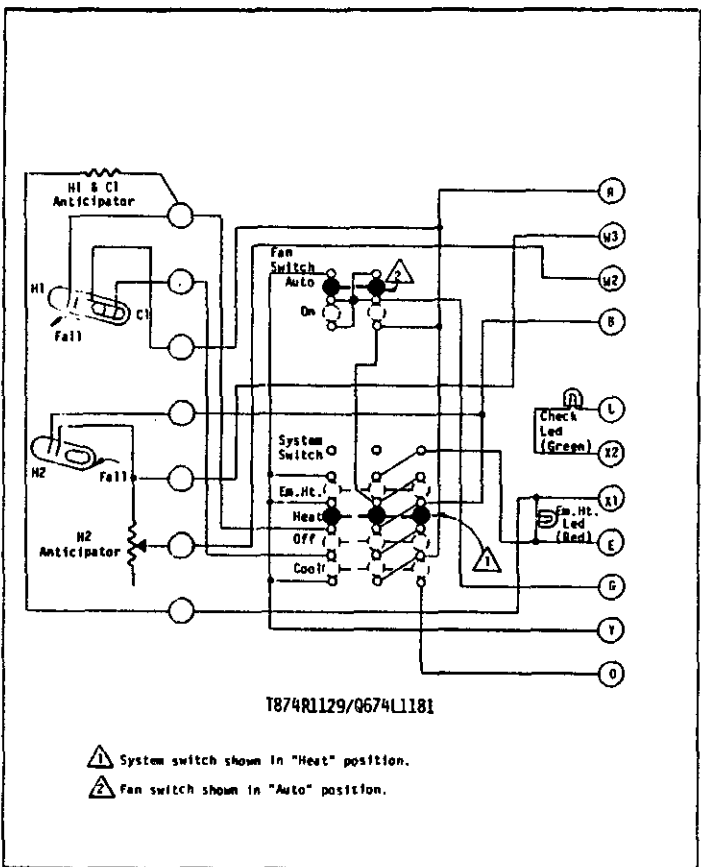

PARTS LIST
WATER SOURCE
PACKAGE HEAT PUMPS

10/85

Part No.	Description	WPV30A	WPVD30A	WPV36A	WPVD36A
5152-046	Blower Assembly	x	x	x	x
8552-035	Capacitor 40/370V 2" round			x	x
8552-007	Capacitor 20/15-370V 2" oval	x	x		
8552-002	Capacitor - blower 5/370V	x	x	x	x
8000-071	Compressor AB225HT-015-A4	x	x		
8000-052	Compressor CRG3-0250-PFV-270			x	x
5052-001	Condenser Coil	x	x		
5052-002	Condenser Coil			x	x
8401-007	Contactora - Compressor	x	x	x	x
5052-005	Desuperheater Coil		x		x
5060-012	Evaporator Coil	x	x	x	x
5651-041	Expansion Valve	x	x	x	x
7004-017	Filter 22x22x1	x	x	x	x
8406-016	High Pressure Switch	x	x	x	x
8105-010	Motor - Blower 1/3 hp	x	x	x	x
8200-003	Motor Mount	x	x	x	x
5451-011	Motor Mounting Parts	x	x	x	x
8201-008	Relay - Blower	x	x	x	x
8201-034	Relay - Lockout	x	x	x	x
5650-005	Reversing Valve	x	x		
5650-009	Reversing Valve			x	x
5650-008	Reversing Valve Solenoid	x	x	x	x
5210-010	Strainer	(2)	(2)	(2)	(2)
8607-011	Terminal Board 24V	x	x	x	x
8407-035	Transformer	x	x	x	x
8300-001	Water Pump		x		x
8408-007	Water Pump Thermostat		x		x
8201-015	Emergency Heat Relay	x	x	x	x
5650-011	Solenoid Valve GS300		x		x
8408-005	Comp. Terminating Thermostat	x	x	x	x
OPTIONAL ITEMS					
8604-080	Duct Heater 5Kw	x	x	x	x
8604-081	Duct Heater 9.8Kw	x	x	x	x
8604-082	Duct Heater 14.7Kw	x	x	x	x
8604-083	Duct Heater 19.2Kw	x	x	x	x
8603-010	Constant Flow Valve 4 GPM	x	x		
8603-011	Constant Flow Valve 5 GPM			x	x
8603-006	Solenoid Valve 24V	x	x	x	x

Minimum net billing \$15.00. Supersedes all previous lists.
 Subject to change without notice.

*Denotes change.

PARTS LIST
WATER SOURCE
PACKAGE HEAT PUMPS

10/85

Part No.	Description	WPV53A	WPVD53A	WPV62A	WPVD62A
*	Blower Housing 10-7	x	x	x	x
5152-010	Blower Wheel DD10-7A	x	x	x	x
8552-030	Capacitor-Comp. 40/440V 2½"Rnd	x	x		
8552-036	Capacitor-Comp. 70/370V 2½"Rnd			x	x
8552-004	Capacitor-Blower 7½/370V 1½Oval	x	x	x	x
8000-072	Compressor - AV144ET-001-A4	x	x		
8000-068	Compressor AC123ET-002-A4			x	x
5052-006	Condenser Coil	x	x		
5052-007	Condenser Coil			x	x
8401-007	Contactora - Compressor	x	x		
8401-003	Contactora - Compressor			x	x
5052-005	Desuperheater Coil		x		x
5060-029	Evaporator Coil	x	x	x	x
5651-046	Expansion Valve	x	x	x	x
7004-018	Filter 25x25x1	x	x	x	x
8401-016	High Pressure Switch	x	x	x	x
8106-017	Motor - Blower 1/2 hp	x	x	x	x
8200-003	Motor Mount	x	x	x	x
5451-011	Motor Mounting Parts	x	x	x	x
8201-008	Relay - Blower	x	x	x	x
8201-015	Relay - Emergency Heat	x	x	x	x
8201-034	Relay - Impedance	x	x	x	x
5650-006	Reversing Valve	x	x	x	x
5650-008	Reversing Valve	x	x	x	x
5650-011	Solenoid Valve		x		x
5210-010	Strainer	(2)	(2)	(2)	(2)
8607-011	Terminal Block	x	x	x	x
8406-020	Toggle Switch		x		x
8407-035	Transformer	x	x	x	x
8300-001	Water Pump		x		x
8408-007	Water Pump Thermostat		x		x
8408-005	Comp. Terminating Thermostat	x	x	x	x
OPTIONAL ITEMS					
8604-080	Duct Heater 5Kw	x	x	x	x
8604-081	Duct Heater 9.8Kw	x	x	x	x
8604-082	Duct Heater 14.7Kw	x	x	x	x
8604-083	Duct Heater 19.2Kw	x	x	x	x
8603-007	Constant flow valve 6 GPM	x	x		
8603-008	Constant flow valve 8 GPM			x	x
8603-006	Solenoid Valve 24V	x	x	x	x

*Please order by model number.

**Denotes change.

Minimum Net Billing \$15.00. Supersedes all previous lists.
 Subject to change without notice.

QUICK REFERENCE TROUBLE-SHOOTING CHART FOR WATER TO AIR HEAT PUMP

POSSIBLE CAUSE	POWER SUPPLY										WATER COIL SECTION										INDOOR SECTION					AUX. HEAT	DEFN.																																																																																																																																																																																						
	LINE VOLTAGE					CONTROL CIRCUIT					REFRIGERANT SYSTEM					WATER COIL					INDOOR BLOWER MOTOR & COIL							CHECK VALVE																																																																																																																																																																																					
POWER FAILURE	●	●	●	●	●	INDOOR BLOWER RELAY	●	●	●	●	●	DISCH. LINE HITTING INSIDE OF SHELL	●	●	●	●	●	VALVE DEFECTIVE	●	●	●	●	●	MOTOR WINDINGS DEFECTIVE	●	●	●	●	●	REFRIGERANT CHARGE LOW	●	●	●	●	●	REFRIGERANT OVERCHARGE	●	●	●	●	●	HIGH HEAD PRESSURE	●	●	●	●	●	LOW HEAD PRESSURE	●	●	●	●	●	HIGH SUCTION PRESSURE	●	●	●	●	●	LOW SUCTION PRESSURE	●	●	●	●	●	NON-CONDENSABLES	●	●	●	●	●	UNEQUALIZED PRESSURES	●	●	●	●	●	SOLENOID VALVE STUCK CLOSED (HTG)	●	●	●	●	●	SOLENOID VALVE STUCK OPEN (HTG OR CLG)	●	●	●	●	●	LEAKING	●	●	●	●	●	DEFECTIVE VALVE OR COIL	●	●	●	●	●	STICKING CLOSED	●	●	●	●	●	LEAKING OR DEFECTIVE	●	●	●	●	●	PLUGGED OR RESTRICTED METERING DEVICE (HTG)	●	●	●	●	●	SCALLED OR PLUGGED COIL (HTG)	●	●	●	●	●	SCALLED OR PLUGGED COIL (CLG)	●	●	●	●	●	WATER VOLUME LOW (HTG)	●	●	●	●	●	WATER VOLUME LOW (CLG)	●	●	●	●	●	PLUGGED OR RESTRICTED METERING DEVICE (HTG)	●	●	●	●	●	PLUGGED OR RESTRICTED METERING DEVICE (CLG)	●	●	●	●	●	FINNED DIRTY OR PLUGGED	●	●	●	●	●	MOTOR WINDING DEFECTIVE	●	●	●	●	●	AIR VOLUME LOW	●	●	●	●	●	MOTOR WINDING DEFECTIVE	●	●	●	●	●	AIR FILTERS DIRTY	●	●	●	●	●	UNDERSIZED OR RESTRICTED DUCTWORK	●	●	●	●	●	STICKING CLOSED	●	●	●	●	●	LEAKING OR DEFECTIVE	●	●	●	●	●	AUX. HEAT UPSTREAM OF COIL	●	●	●	●	●

POSSIBLE CAUSE

DENOTES COMMON CAUSE

DENOTES OCCASIONAL CAUSE

PROBLEM CONDITION

- COMPRESSOR WILL NOT RUN
- NO POWER AT CONTACTOR
- COMPRESSOR WILL NOT RUN
- POWER AT CONTACTOR
- COMPRESSOR "HUMS" BUT WILL NOT START
- COMPRESSOR CYCLES ON OVERLOAD
- THERMOSTAT CHECK LIGHT
- LITTLE-LOCKOUT RELAY
- COMPRESSOR OFF ON HIGH
- PRESSURE CONTROL
- COMPRESSOR OFF ON LOW
- PRESSURE CONTROL
- COMPRESSOR NOISY

HEATING OR COOLING CYCLES

HEAD PRESSURE TOO HIGH

HEAD PRESSURE TOO LOW

SUCTION PRESSURE TOO HIGH

SUCTION PRESSURE TOO LOW

I. D. BLOWER WILL NOT START

I. D. COIL FROSTING OR ICING

HIGH COMPRESSOR AMPS

EXCESSIVE WATER USAGE

COOLING

COMPRESSOR RUNS

CONTINUOUSLY—NO COOLING

LIQUID REFRIGERANT FLOODING

BACK TO COMPRESSOR

COMPRESSOR RUNS

CONTINUOUSLY—NO HEATING

REVERSING VALVE

DOES NOT SHIFT

LIQUID REFRIGERANT FLOODING

BACK TO COMPRESSOR

AUX. HEAT ON I. D. BLOWER OFF

EXCESSIVE OPERATING COSTS

ICE IN WATER COIL

HEATING CYCLE

PERFORMANCE CHECK
WATER SOURCE HEAT PUMPS

INSTALLER PLEASE FILL OUT AND
RETAIN WITH UNIT

DATE OF INSTALLATION _____ MODEL NO(S) _____ SERIAL NO(S) _____

ITEM	COOLING	HEATING	JOB NUMBER
1. HEAD PRESSURE			NAME OF INSTALLER
2. SUCTION PRESSURE			NAME OF OWNER
3. WATER TEMP. (IN)			ADDRESS
4. WATER TEMP. (OUT)			CITY STATE
5. WATER PRESSURE (IN)			
6. WATER PRESSURE (OUT)			FIELD COMMENTS:
7. WATER FLOW (GPM)			
8. AMPERES (BLOWER)			
9. AMPERES (COMPRESSOR)			
10. LINE VOLTAGE (COMPRESSOR RUNNING)			
11. AIR TEMP. (IN) D.B.			
W.B. ~			
12. AIR TEMP. (OUT) D.B.			
W.B.			
13. DESUPERHEATER H ₂ O TEMP. (IN)			
14. DESUPERHEATER H ₂ O TEMP. (OUT)			

*This PERFORMANCE CHECK SHEET should be
filled out by installer and retained with unit.*

These curves are based upon 80°DB, 67°WB R.A. Temp. and Rated CFM (airflow) for cooling and 70°DB for heating and should be used for reference purposes only. If there is any doubt as to correct operating charge being in the system, the charge should be removed, system evacuated, and recharged according to serial plate instructions.

① Operation of the unit with these water temperatures requires the addition of antifreeze (closed loop systems). Pressures may vary 5 to 15% depending on the type and degree of concentration of the antifreeze solution.

NOTE: Compressor compartment panels must be in place when measuring pressures.

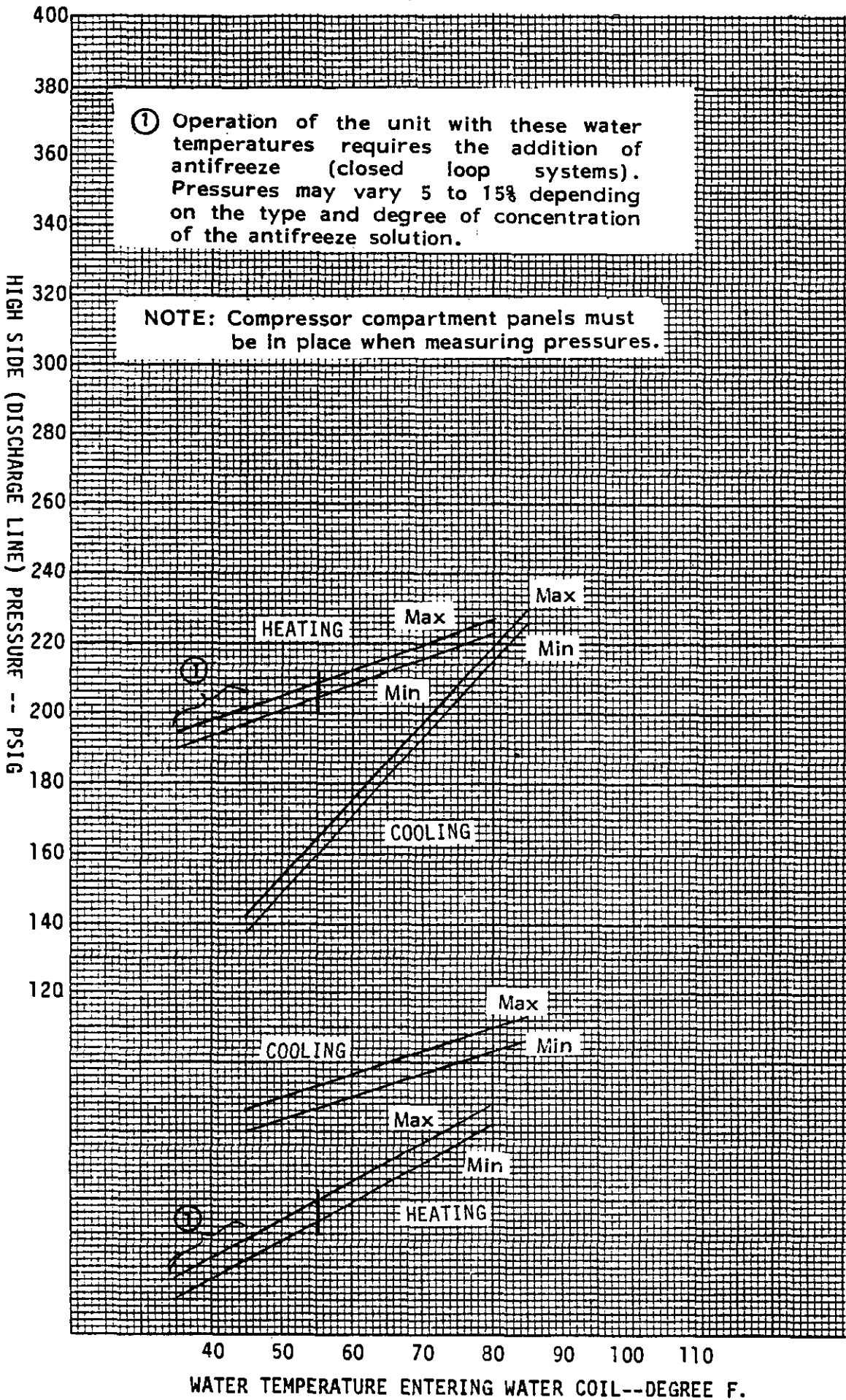

NOTE: On units with heat recovery coil (WPVD) turn water pump switch to "off" before measuring refrigerant pressures.

LOW SIDE PRESSURE--PSIG
(SUCTION LINE)

These curves are based upon 80°DB, 67°WB R.A. Temp. and Rated CFM (airflow) for cooling and 70°DB for heating and should be used for reference purposes only. If there is any doubt as to correct operating charge being in the system, the charge should be removed, system evacuated, and recharged according to serial plate instructions.

① Operation of the unit with these water temperatures requires the addition of antifreeze (closed loop systems). Pressures may vary 5 to 15% depending on the type and degree of concentration of the antifreeze solution.

NOTE: Compressor compartment panels must be in place when measuring pressures.

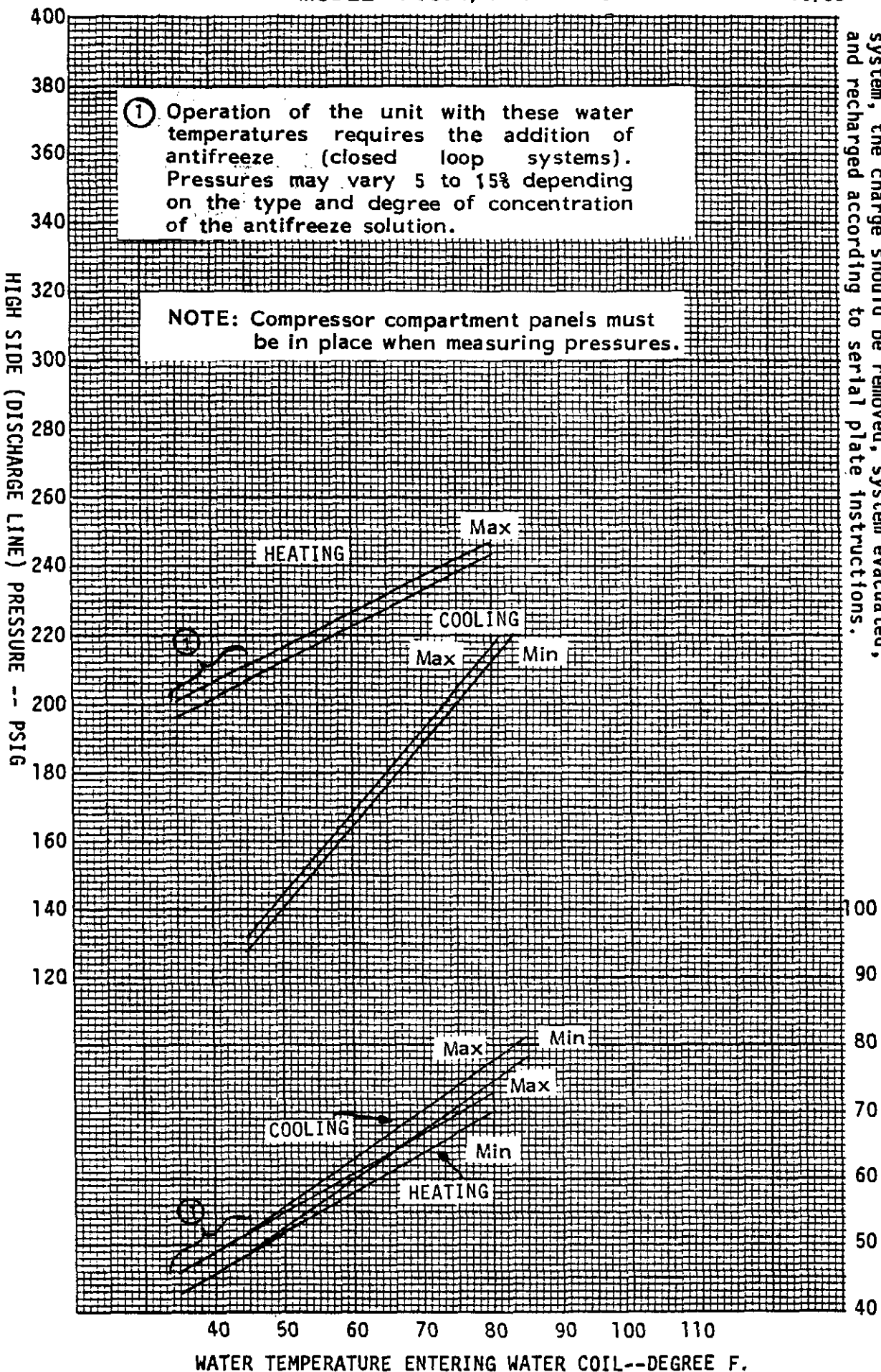

LOW SIDE PRESSURE--PSIG
(SUCTION LINE)

NOTE: On units with heat recovery coil (WPVD) turn water pump switch to "off" before measuring refrigerant pressures.

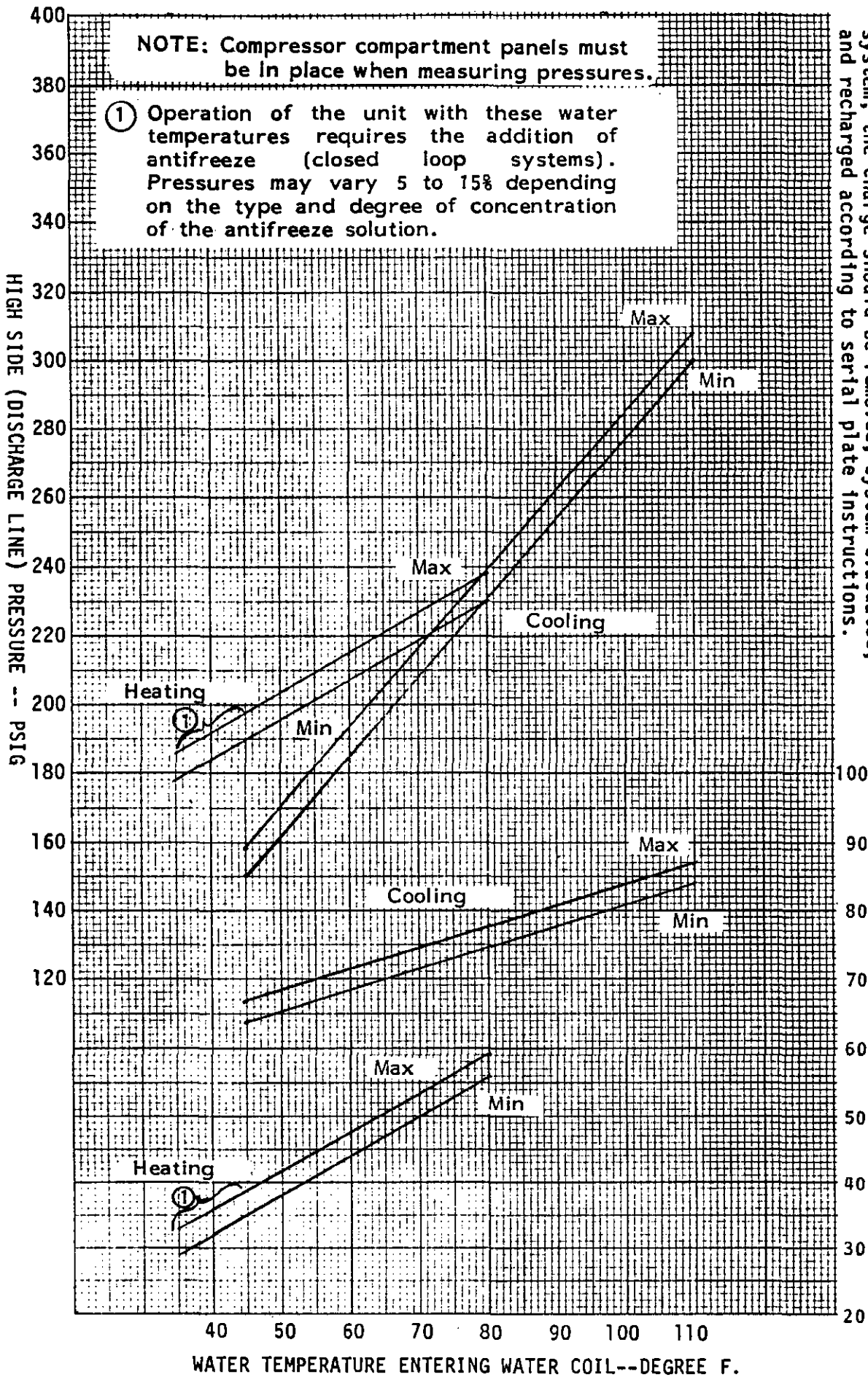

These curves are based upon 80°DB, 67°WB R.A. Temp. and Rated CFM (airflow) for cooling and 70°DB for heating and should be used for reference purposes only. If there is any doubt as to correct operating charge being in the system, the charge should be removed, system evacuated, and recharged according to serial plate instructions.

NOTE: On units with heat recovery coil (WPVD) turn water pump switch to "off" before measuring refrigerant pressures.

LOW SIDE PRESSURE--PSIG (SUCTION LINE)

These curves are based upon 80°DB, 67°WB R.A. Temp. and Rated CFM (airflow) for cooling and 70°DB for heating and should be used for reference purposes only. If there is any doubt as to correct operating charge being in the system, the charge should be removed, system evacuated, and recharged according to serial plate instructions.

① Operation of the unit with these water temperatures requires the addition of antifreeze (closed loop systems). Pressures may vary 5 to 15% depending on the type and degree of concentration of the antifreeze solution.

NOTE: Compressor compartment panels must be in place when measuring pressures.

HIGH SIDE (DISCHARGE LINE) PRESSURE -- PSIG

LOW SIDE PRESSURE--PSIG (SUCTION LINE)

NOTE: On units with heat recovery coil (WPVD) turn water pump switch to "off" before measuring refrigerant pressures.

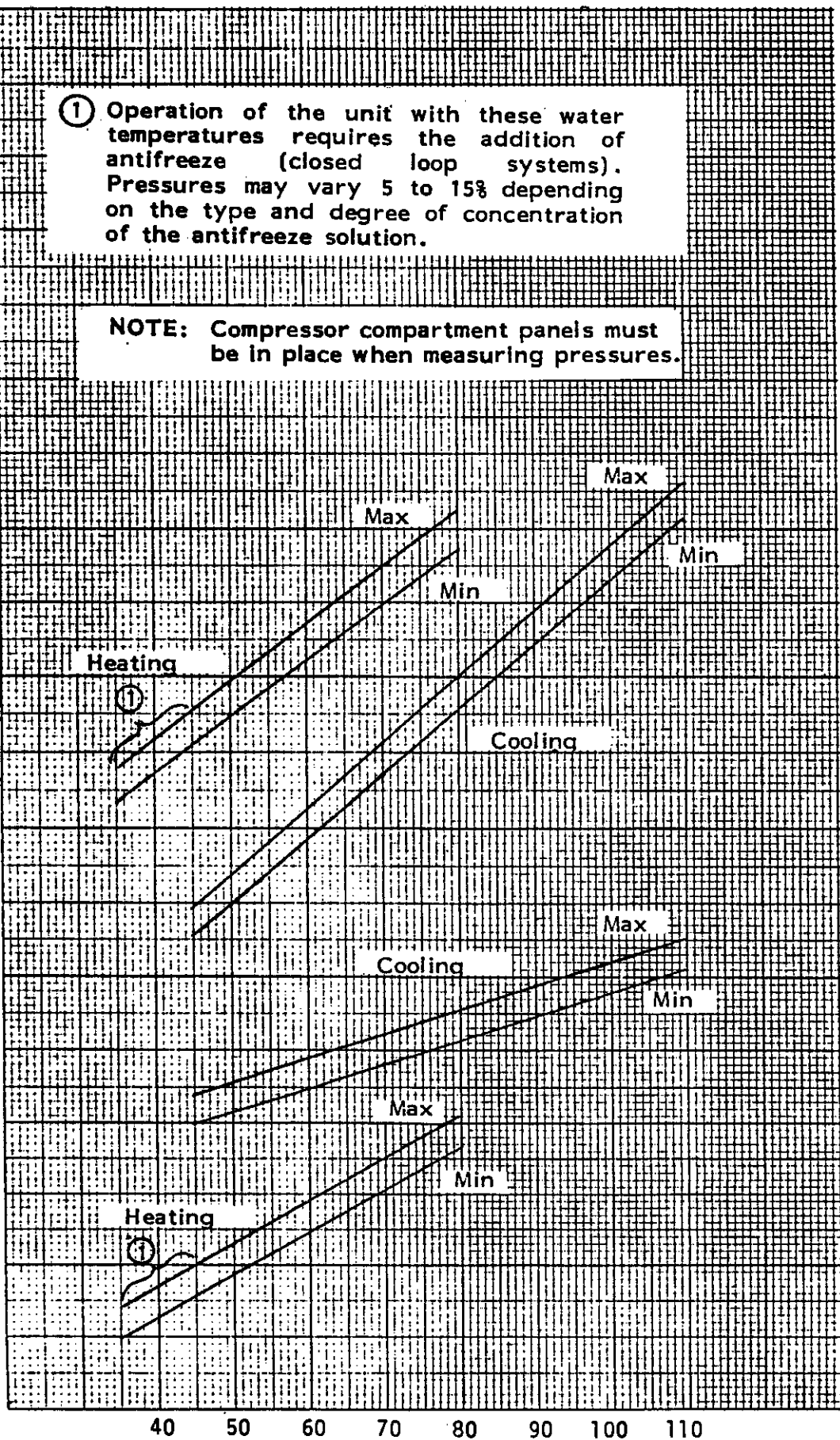

WATER TEMPERATURE ENTERING WATER COIL--DEGREE F.

⚠ For 208V operation move this wire to 208V transformer tap.

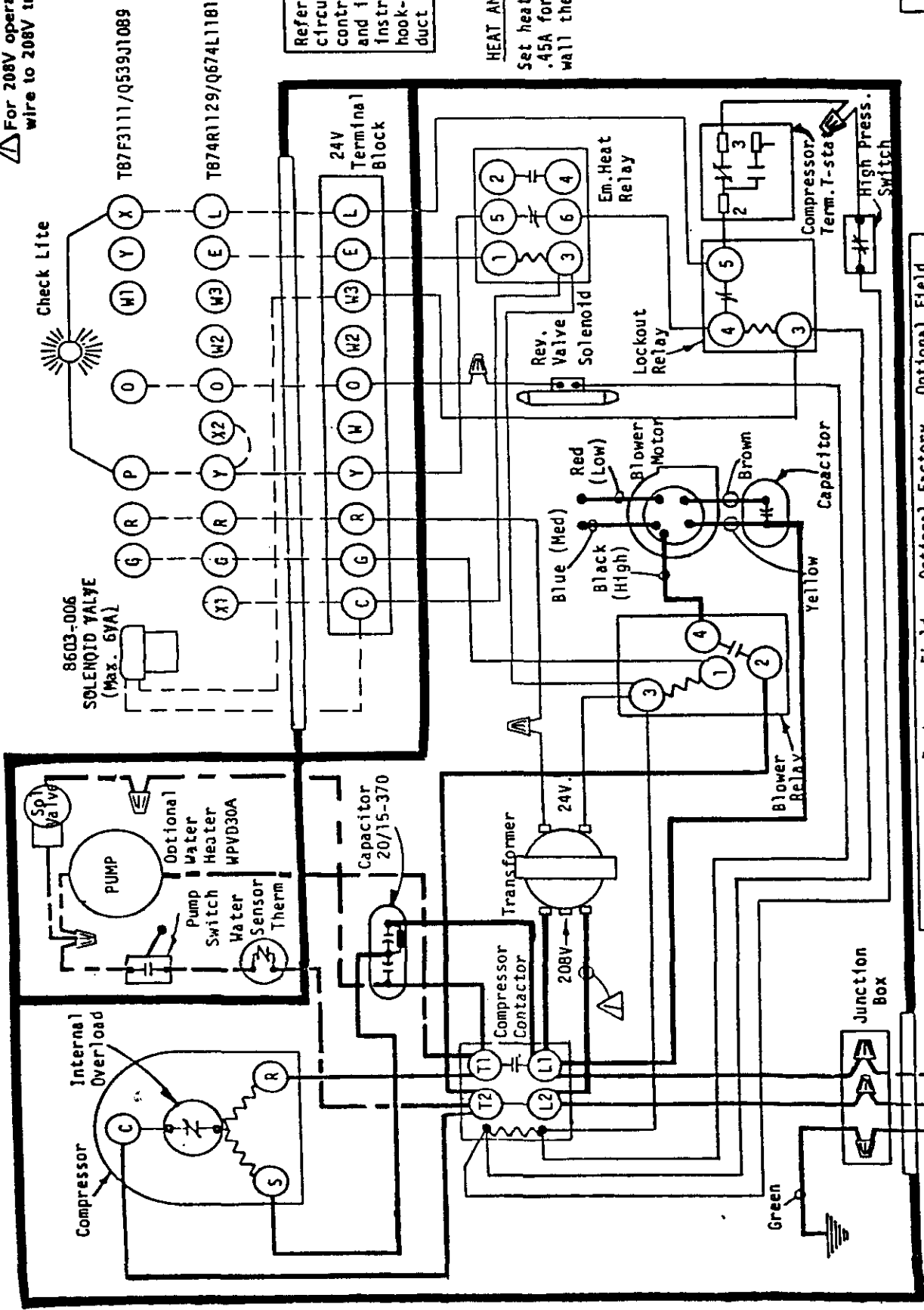

Refer to control circuit wiring on control panel cover and instructions for hook-up of optional duct heater.

HEAT ANTICIPATOR SETTING
Set heat anticipator at .45A for either type of wall thermostat.

MODELS
WPV30A
WPVD30A

4049-803B

Factory Wiring	Field Wiring	Optional Factory Wiring	Optional Field Wiring
_____	_____	_____	_____
Low Voltage	_____	_____	_____
High Voltage	_____	_____	_____

230/208-60-1

USE COPPER WIRE ONLY

⚠ For 208V operation move this wire to 208V transformer tap.

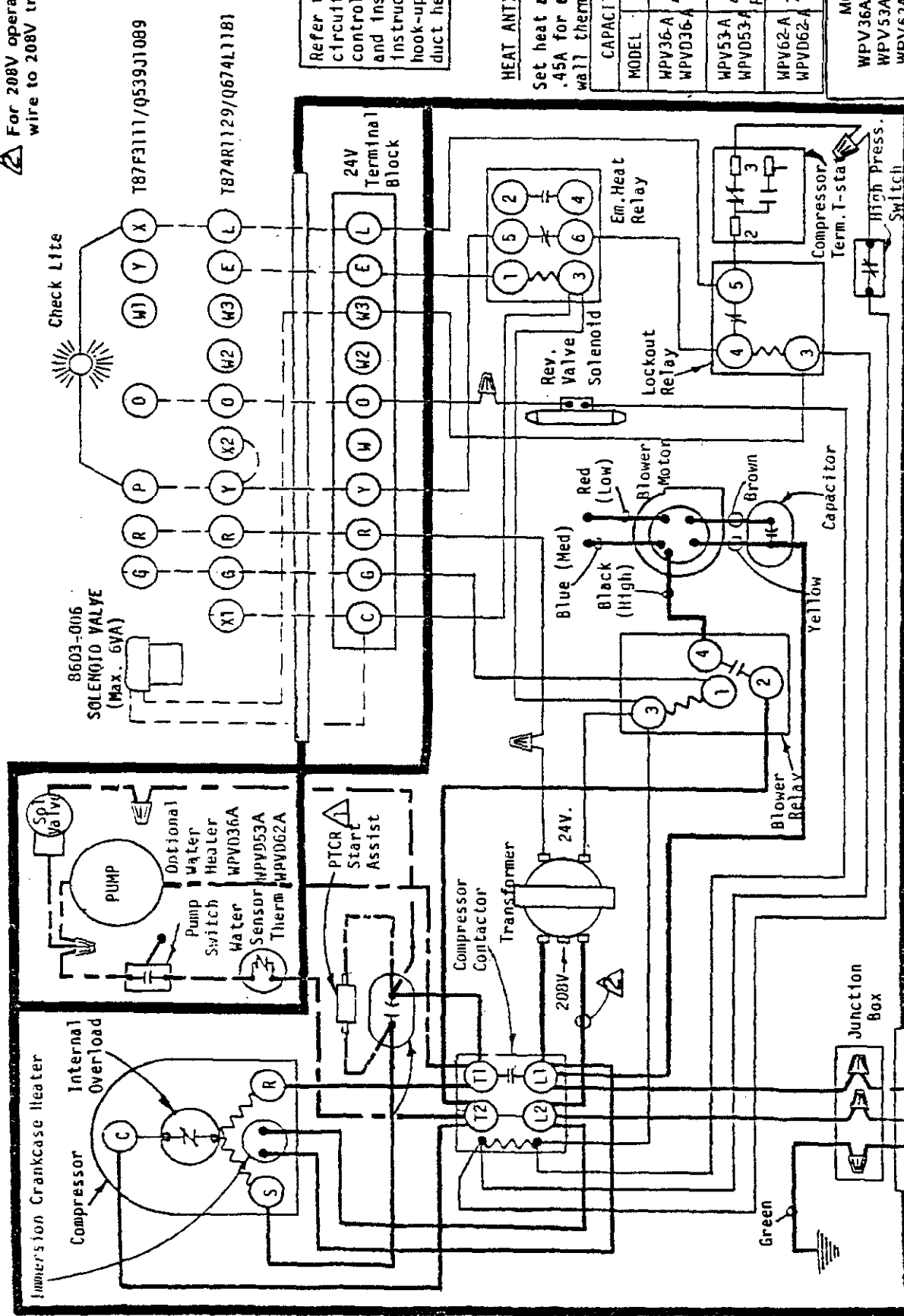

Refer to control circuit wiring on control panel cover and installation instructions for hook-up of optional duct heater.

HEAT ANTICIPATOR SETTING
Set heat anticipator at .45A for either type of wall thermostat.

CAPACITOR RATINGS	
MODEL	COMP. BLOMER
WPV36-A	40/370
WPV36-A	5/370
WPV53-A	40/440
WPV53-A	7.5/370
WPV62-A	70/370
WPV62-A	7.5/370

MODELS
WPV36A, WPVD36A
WPV53A, WPVD53A
WPV62A, WPVD62A

Water Source Heat Pump
4054-803C

⚠ PTCR Start Assist on WPV53A, WPVD53A, WPV62A, WPVD62A only

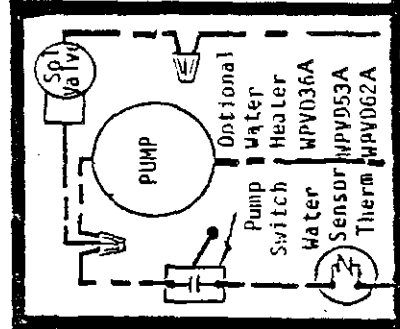

Factory Wiring _____
 Field Wiring _____
 Optional Factory Wiring _____
 Optional Field Wiring _____

Low Voltage _____
 High Voltage _____

USE COPPER WIRE ONLY
230/208-60-1