

LO-BOY
High Economy Gas Furnace
OWNERS INFORMATION MANUAL

FOR YOUR SAFETY

If you smell gas:

1. Open windows
2. Don't touch electrical switches
3. Extinguish any open flame
4. Immediately call your gas supplier

FOR YOUR SAFETY

Do not store or use gasoline or other flammable vapors and liquids in the vicinity of this or any other appliance.

GENERAL

The warnings shown on the cover of this manual and the information on the following pages are very important and should be fully read and understood by the operator of this equipment. Please take the few minutes necessary to completely read this booklet, and if there are any questions when you are through, ask your installer to review them with you. Please retain this booklet for future reference.

CLEARANCES

There are certain minimum installation clearances from the furnace cabinet and sheet metal plenum attached to the top of the furnace to any combustible materials. These clearances for each model of furnace are shown on the furnace rating plate (located in the burner compartment) and are the responsibility of the furnace installer during the installation of the appliance.

It is the owner's responsibility to make sure these clearances are always maintained thereafter. Additionally, a minimum of 24 inches for serviceability of furnace is required from the front side of all models.

A furnace installed in an attic or other insulated space must be kept free and clear of insulating material. The furnace area should be examined when the furnace is installed or additional insulation material is added. Insulating materials may be combustible.

BE SURE TO OBSERVE THE FOLLOWING RULES:

- A. **DO NOT** allow any cardboard, newspapers, or any other combustible material (this includes wood, 2x4's, etc.) within the above specified minimum clearances. This includes placing any combustibles on or against the sheet metal plenum attached to the top of the furnace.
- B. The furnace area is to be kept clear of gasoline solvents, painting supplies, and any other flammable vapors or liquids.

COMBUSTION AND VENTILATING AIR

Whether your furnace is installed in a closet, basement, garage or other location as dictated by the particular application, an adequate source of fresh outside air has been provided by the installer to allow proper combustion and venting of the products of combustion to the outside of the building.

It is again the responsibility of the owner to assure that this important flow of combustion and ventilating air is not obstructed from reaching the furnace.

LIGHTING AND SHUT-DOWN INSTRUCTIONS

- A. **Intermittent Pilot** - This is an electric ignition system which lights and proves the pilot flame presence before allowing the main burner to open.

WARNING: Should overheating occur, or the gas supply fail to shut off, shut off the manual gas valve to the appliance before shutting off the electrical supply.

INTERMITTENT PILOT

TO SHUT DOWN FURNACE:

1. Set thermostat, lowest setting.
2. Turn gas valve to OFF position.
3. Switch off electric supply to furnace.

OPERATING INSTRUCTIONS

1. Set the thermostat to lowest setting, electric supply and gas valve to OFF position and wait five minutes.
2. Turn gas valve ON, restore electric power and set room thermostat. Setting must be above room temperature to start burner operation.
3. **DO NOT** attempt to manually light the pilot, it will light automatically.
4. If the burner fails to ignite, repeat steps 1 through 4 of the operating instructions.
5. If the burner again fails to ignite, shut down the furnace and have qualified service personnel investigate the problem.

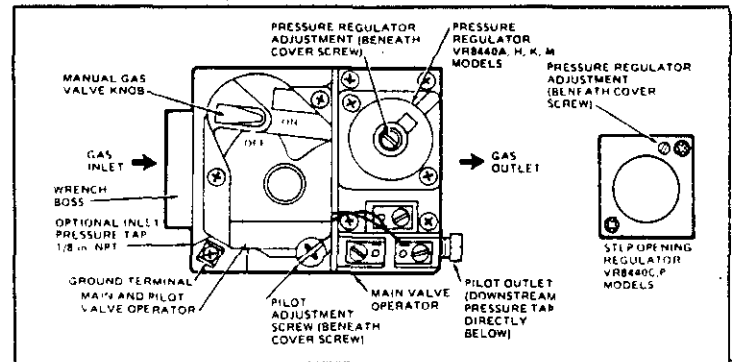

Top view of VR8440 gas control.

AIR FILTERS

It is the owner's responsibility to check the condition of the air filters on at least a monthly basis when the furnace is in use and to clean or replace whenever it is necessary.

PERMANENT TYPE FILTER (usually foam type) are washable. Use a solution of soapy water, followed by a rinse in clear water and then dried by tapping the frame against a solid object.

NEVER OPERATE A FURNACE WITHOUT A FILTER
NEVER SUBSTITUTE A THROWAWAY (FIBERGLASS) FOR A PERMANENT (FOAM) TYPE

FILTER SIZES FOR GAS FURNACES	
Model	Size
1L85D42A	(1) 18-3/4 x 20 P
1L115D48A	(1) 22-3/4 x 20 P
1L145D60A	(2) 13 x 20 P
P = Permanent type filter.	

FIGURE 1.

IL-SERIES LO-BOY FURNACE FILTER REPLACEMENT

To remove filters from Lo-Boy models, you must first remove the rear blower-filter access door. Then, just lift filter up and pull out.

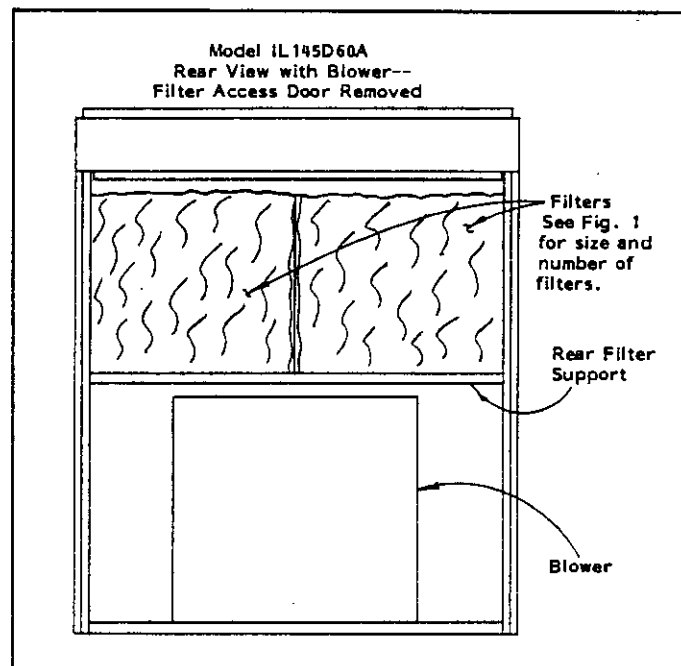
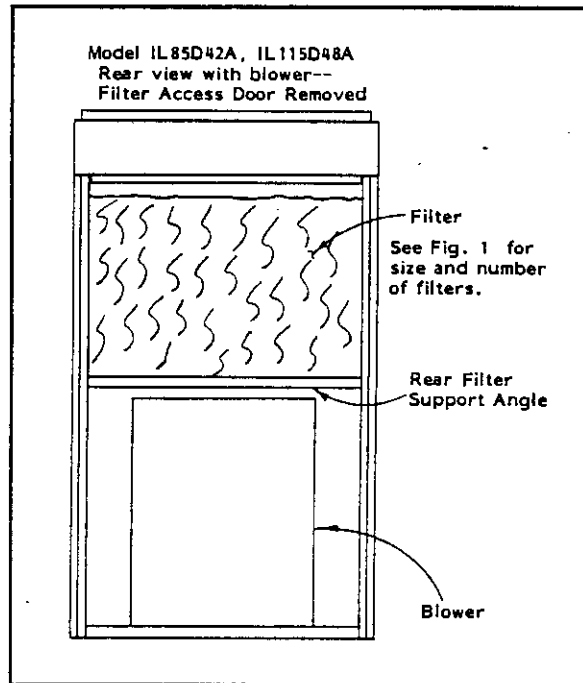

LUBRICATION REQUIREMENTS

All models have permanently lubricated blower motors. The induced draft blower motor must be lubricated every six months with SAE20 motor oil.

FURNACE EXAMINATION

The furnace and the vent system (commonly called the flue pipe, smoke pipe, chimney, etc.) should be inspected yearly by a qualified service agency, generally prior to the heating season. Detailed procedures for this inspection are contained in the instructions booklet and should be handled by the qualified service agency only.

Periodic examinations of the combustion area and vent system should also be conducted by the owner on a regular basis, preferably every month but at least every two months, during the heating season.

The following procedure should be followed for the periodic inspection as conducted by the owner:

1. Set the wall thermostat to the "OFF" position or lower the set point lever to a temperature well below the existing room temperature. Shut off electric power to the furnace. A switch should be mounted either on the outside of the furnace or adjacent to the furnace for this purpose.
2. Remove the furnace door exposing the burner compartment. This is accomplished on the IL-Series by sliding door upwards to unhook the top and disengaging the bottom offset.
3. Using flashlight or trouble light, observe the burner compartment and where the burner(s) extend into the heat exchanger. There should be very minimal scaling or sooting in this area. Some loose debris may have fallen down on to the floor of the heat exchanger from the upper flue passageways, and this may be vacuumed out. Also observe the sides of the heat exchanger for "HOT SPOTS" due to improper burner alignment or overfiring and give particular attention to any area where it looks like there may be any deterioration from corrosion or rusting. On the IL-Series multiple burners, observe for any corrosion on the burners themselves. Should anything appear questionable, contact your service agency.
4. On intermittent pilot models, the pilot lights only when the thermostat calls for heat and the main burner lights within a few seconds thereafter. It is recommended that any observation of the pilot or main burner operation be done only with the burner compartment door in place and viewing through the combustion air slots. Any adjustments to the pilot flame should be done by a competent service agency.
5. Inspect the flue pipe the full distance from the furnace to chimney or to exit point from the building, observing for corrosion and possible leakage that might result in products of combustion entering the living area.

WARNING: LEAKAGE OF PRODUCTS OF COMBUSTION INTO THE LIVING AREA MAY RESULT IN ASPHYXIATION.

Any questionable flue pipe should be replaced. Considering its importance, it is relatively cheap insurance to protect your family. Consult your service agency.

6. Replace the burner compartment access doors by reversing the procedure as outlined under step 2 above.
7. Restore the electrical power to the furnace by turning the switch back on. Adjust the thermostat to call for heating operation.
8. Observe the main burners in operation viewing through the combustion air slots. The flame should be mostly "blue" with possibly a little "yellow" at the tips of the flames. The flames should be in the center of the heat exchanger compartments and not impinging on the heat exchanger surfaces themselves.
9. Observe the fire until the blower starts (there is a normal delay period until the heat exchanger warms up). There should be no change in the size or shape of the flame. If there is any wavering or blowing of the flame on blower start-up, it is an indication of a possible leak in the heat exchanger. Turn off the main electrical switch to the furnace and the gas valve in the gas line leading to the furnace, and call your service agency.

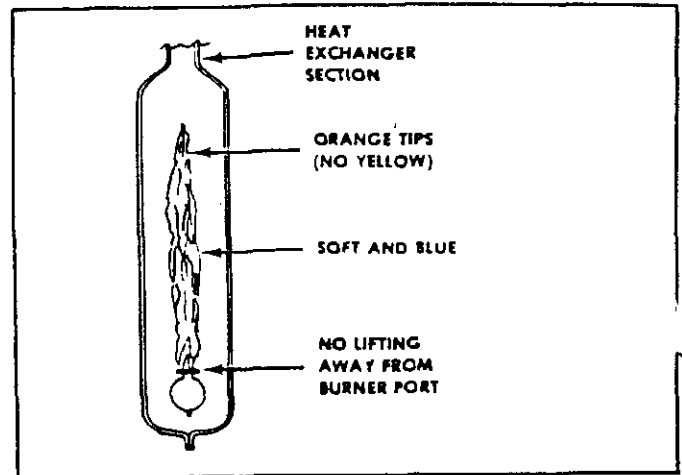

IL-SERIES
(Multiple Section Type)

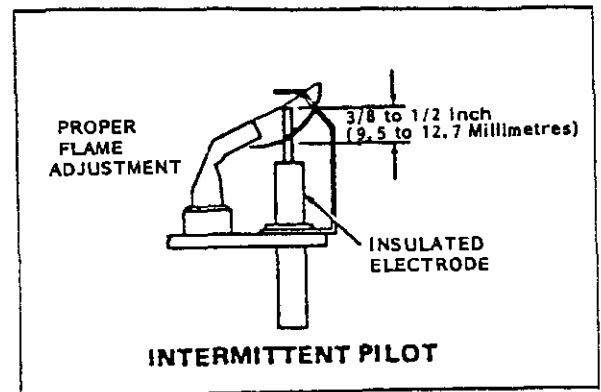

INTERMITTENT PILOT