

# **INSTALLATION INSTRUCTIONS**

## **ROOF MOUNT PACKAGED HEAT PUMP**

### **MODELS**

**RPMH42**

**RPMH48**

**RPMH60**

**SPECIALLY DESIGNED FOR ROOFTOP  
HEATING/COOLING APPLICATIONS**

COPYRIGHT APRIL, 1989  
BARD MANUFACTURING COMPANY  
BRYAN, OHIO

## INDEX

Important . . . . .	5
Shipping Damage . . . . .	5
Unpacking The Self-Contained Unit . . . . .	5
General . . . . .	5
Installation. . . . .	6
Ductwork . . . . .	6
Locating The Unit . . . . .	6
Roof Curb Fabrication . . . . .	6
Optional Electric Heater Packages . . . . .	6
Installation . . . . .	7
Wiring--Main Power . . . . .	7
Condensate Drainage . . . . .	7
Wiring--24V Control Circuit . . . . .	7
Compressor Malfunction Relay (1-Phase Models Only) . . . . .	8
Pressure Service Ports . . . . .	8
Thermostat Indicator Lamps . . . . .	8
Emergency Heat Position . . . . .	8
Compressor Cut-Off Thermostat and Outdoor Thermostat . . . . .	8
Compressor Cut-Off and Outdoor Thermostat Wiring . . . . .	9
Heat Anticipation . . . . .	9
Sequence of Operation . . . . .	10
Crankcase Heaters . . . . .	10
Air Filters . . . . .	11
Fresh Air Intake . . . . .	11
Defrost Cycle . . . . .	11
Refrigerant Charge . . . . .	12
Service Hints . . . . .	12

## INDEX OF FIGURES AND TABLES

Figure 1 . . . . .	1
Figure 2 . . . . .	2
Figure 3 . . . . .	7
Figure 4 . . . . .	8
Figure 5 . . . . .	9
Figure 6 . . . . .	10
Figure 7 . . . . .	11

Table 1 . . . . .	3
Table 2 . . . . .	3
Table 3 . . . . .	4
Table 4 . . . . .	4
Table 5 . . . . .	9
Table 6 . . . . .	12

Figure 1

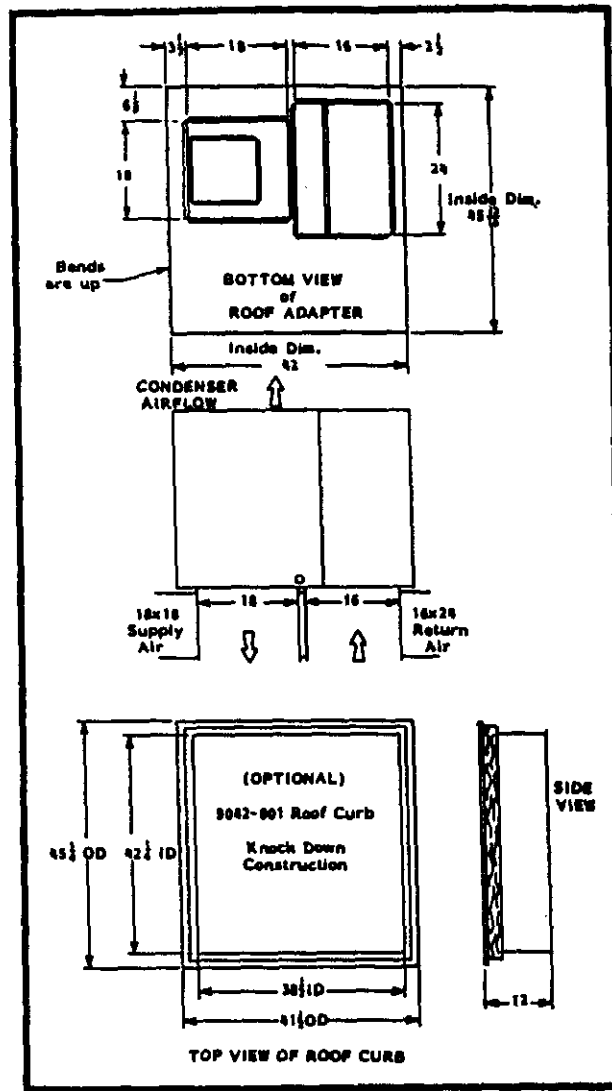

**TYPICAL CONSTRUCTION FOR DIMENSIONAL LUMBER EXTENSION CONSTRUCTION**

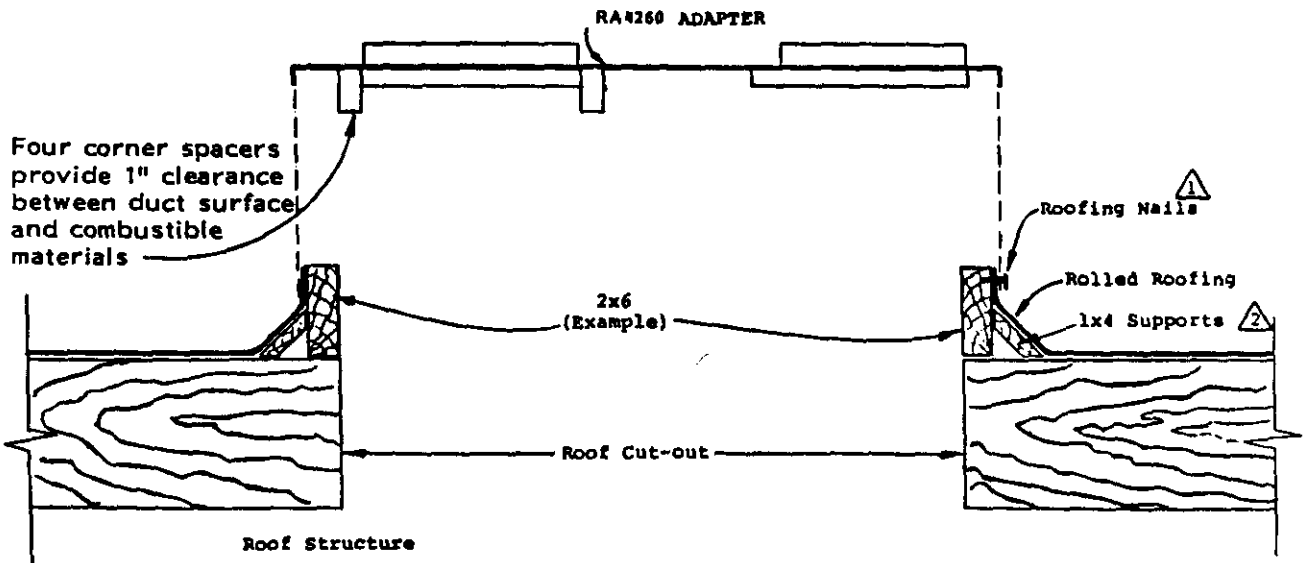

- ⚠ 1 Nail 3/4" from top.
- ⚠ 2 Provides support to roofing material, prevents sharp bends and cracking.

FIGURE 2

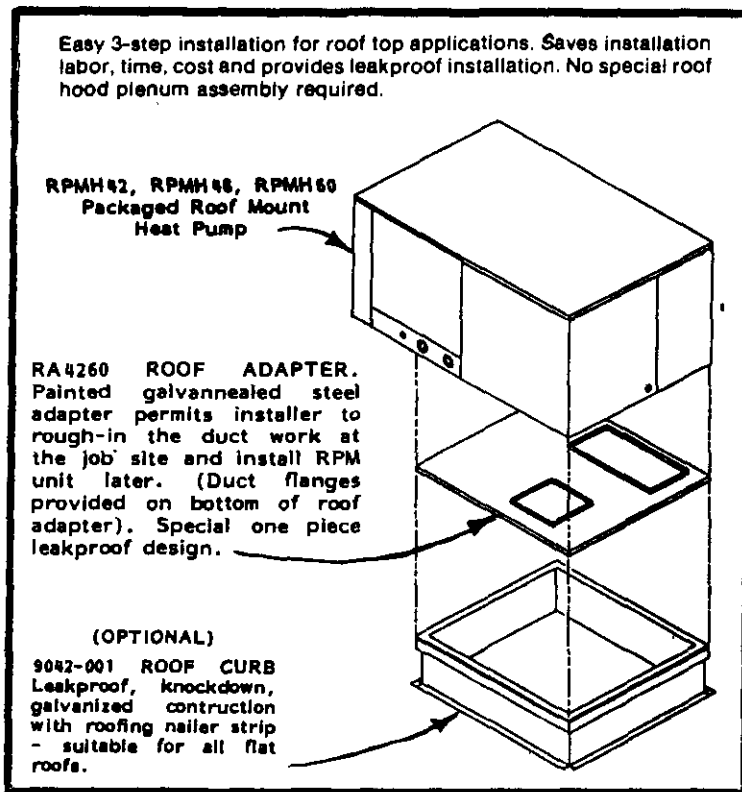

### UNIT LIFTING BRACKET

Four lifting brackets with fasteners are supplied with the basic unit. These brackets are inserted next to the unit control panel. Access to these brackets is gained by removing the outer control panel cover. These brackets can be installed using the mating holes along the unit base.

### TIE DOWN BRACKET

Two tie down brackets are supplied. After the unit has been lifted on to the roof adapter/curb assembly, attach the tie down brackets to the lifting brackets as shown.

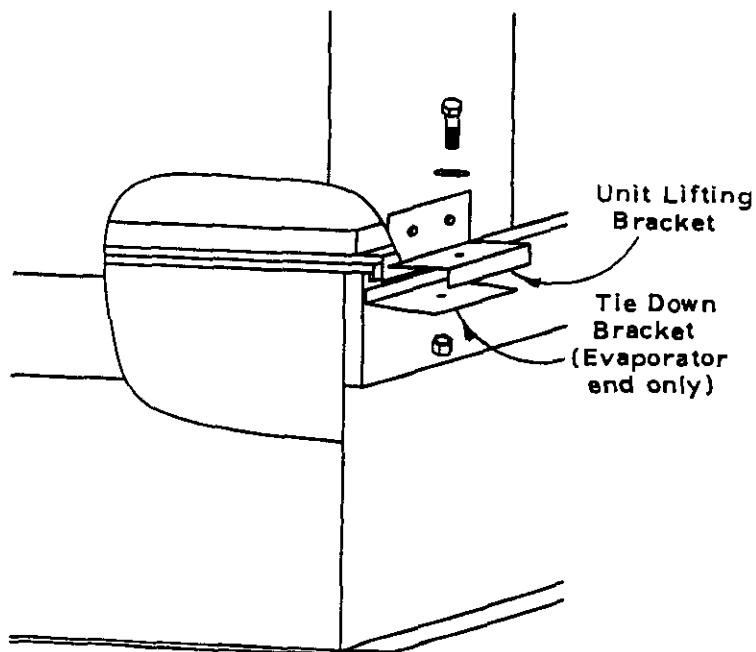

TABLE 1  
INDOOR BLOWER PERFORMANCE  
CFM -- DRY COIL WITH FILTER

B.S.P. in H <sub>2</sub> O	RPM42			RPM48			RPM60	
	High Speed	Medium Speed	Low Speed	High Speed	Medium Speed	Low Speed	High Speed	Low Speed
.0	1995	1920	1775	2160	2075	1860	2250	2100
.10	1935	1870	1735	2080	1980	1810	2180	2045
.20	1865	1800	1670	1995	1920	1735	2100	1975
.30	1770	1700	1600	1910	1840	1670	2020	1910
.40	1680	1610	1525	1820	1745	1590	1925	1840
.50	1580	1525	1430	1715	1650	1510	1845	1750
.60	1480	1420	1340	1615	1550	1420	1740	1660

TABLE 2  
OPTIONAL FIELD INSTALLED HEATER PACKAGES  
ARE ONLY TO BE USED WITH THE HEAT PUMPT MODELS AS INDICATED BELOW

Heater Package Model No.	Volts and Phase	①	①	①	①	①	①			
		R P M H 4 2	R P M H 4 2	R P M H 4 2	R P M H 8 8	R P M H 8 8	R P M H 8 8	R P M H 6 0	R P M H 6 0	R P M H 6 0
EH5RA-A10	240/208-1	S	A	A	S	A	A	S	A	A
EH5RA-A15		S	A	A	S	A	A	S	A	A
EH5RA-A20		S	A	A	S	A	A	S	A	A
EH5RA-A25		S	A	A	S	A	A	S	A	A
EH5RA-B09	240/208-3	A	S	A	A	S	A	A	S	A
EH5RA-B15		A	S	A	A	S	A	A	S	A
EH5RA-B24		A	S	A	A	S	A	A	S	A
EH5RA-C09	480-3	A	A	S	A	A	S	A	A	S
EH5RA-C15		A	A	S	A	A	S	A	A	S
EH5RA-C24		A	A	S	A	A	S	A	A	S

S Standard application--Heater volts and phase same as basic unit.

A Alternate application--Heater volts and phase different from basic unit.

① Maximum amount of electric heat which operated in conjunction with the compressor during heating mode is 15KW, 1 and 3 phase. The balance of the heat can be operated only during compressor cutoff or emergency heat mode.

TABLE 3  
ELECTRICAL DATA

Model	Rated Volts & PH	Operating Voltage Range	Max. Unit Amps 230/208	Maximum Fuse Or Ckt. Brk *	Minimum Circuit Ampacity	Field Power Wiring**	Ground Wire Size**
				Ckt. A	Ckt. A	Ckt. A	Ckt. A
RPMH42	230/208-1	197-253	27.3/29.6	50	36	8	10
RPMH42-B	230/208-3	187-253	20/22.5	40	26	10	10
RPMH42-C+	460-3	414-506	10.5	15	15	14	14
RPMH48	230/208-1	197-253	29.3/32	60	38	8	10
RPMH48-B	230/208-3	187-253	22/24	40	28	10	10
RPMH48-C+	460-3	414-506	11.2	20	15	14	14
RPMH60	230/208-1	197-253	34.8/38.8	60	47	6	10
RPMH60-B	230/208-3	187-253	26.3/28.3	50	34	8	10
RPMH60-C+	460-3	414-506	13.4	25	16	12	12

\*Maximum time delay fuse or HACR type circuit breaker. HACR not applicable to 460 volt.

\*\*60 degree C copper wire size, basic unit only.

+460 volt not U.L. listed.

TABLE 4  
OPTIONAL FIELD-INSTALLED ELECTRIC HEATER TABLE

Heater Pkg. Model No.	Unit Volts Phase	Htr. KW & Cap. @240V (or 480V if applicable)		Heater KW & Capacity @208 Volts		Htr Amps @240/208V (or 480V if Applicable)	Heater Internal Fuses	Circuit B				
								No. Field Ckts.	Minimum Circuit Ampacity	Maximum Overcurrent Protection	Field Power Wiring ①	Ground Wire Size ②
EHSRA-A10	240/208-1	10	34,100	7.5	25,600	41.6/36.2		1	53/46	60/50	6/6	10
EHSRA-A15	240/208-1	15	51,200	11.25	38,400	62.5/54.1	30/60	1	79/68	80/70	3/14	8
EHSRA-A20	240/208-1	20	68,200	15.0	51,200	83.2/72.1	60/60	1	104/91	110/100	2/3 ③	6
EHSRA-A25	240/208-1	25	85,300	18.75	64,000	104.2/90.1	30/60/60	1	130/113	150/125	1/2 ③	6
EHSRA-B09	240/208-3	9	30,700	6.75	23,000	21.7/18.7		1	28/24	30/25	10/10	10
EHSRA-B15	240/208-3	15	51,200	11.25	38,400	36.2/31.2		1	46/39	50/40	6/8	10
EHSRA-B24	240/208-3	24	81,900	18.0	61,400	57.9/50.0	40/40/40	1	73/63	80/70	3/4	8
EHSRA-C09	460-3	9	30,700	6.75	23,000	10.8		1	15	15	14	14
EHSRA-C15	460-3	15	51,200	11.25	38,400	18.0		1	23	25	10	10
EHSRA-C24	460-3	24	81,900	18.0	61,400	28.8		1	36	40	8	10

① Based on wire suitable for 60 degrees C. Other wiring materials must be rated for marked "Minimum Circuit Ampacity" or greater.

② Based upon Table 250-95 of N.E.C. 1984. See electrical data for basic air conditioner for Ckt. A wiring specification requirements.

③ For ampacities over 100 amperes use wire suitable for at least 75 degrees C.



## **IMPORTANT**

The equipment covered in this manual is to be installed by trained, experienced service and installation technicians. Any heat pump is more critical of proper operating, charge and an adequate duct system than a straight air conditioning unit. All ductwork, supply and return, must be properly sized for the design air flow requirement of the equipment. Air Conditioning Contractors of America (ACCA) is an excellent guide to proper sizing. All ductwork or portions thereof not in the conditioned space should be properly insulated in order to both conserve energy and prevent condensation or moisture damage.

## **SHIPPING DAMAGE**

Upon receipt of equipment, the carton should be checked for external signs of shipping damage. If damage is found, the receiving party must contact the last carrier immediately, preferably in writing, requesting inspection by the carrier's agent.

## **UNPACKING THE SELF-CONTAINED UNIT**

It is recommended that the unit be unpacked at the installation site to minimize damage due to handling.

1. Cut and remove the metal band from around unit.
2. Remove the carton from the unit.
3. The installation manual is contained in an envelope shipped with the unit. Make sure that it does not get lost.
4. Carefully block up the unit and remove the shipping skid.
5. CAUTION: DO NOT tip the unit on its side. Oil may enter the compressor cylinders and cause starting or operating trouble. If unit has been set on its side, restore to upright position and do not run for several hours. Also run intermittently for a few seconds. Do this three or four times with three minutes in between. Observe abnormal compressor noise.

## **GENERAL**

The refrigerant system is completely assembled and charged. All internal wiring is complete.

These instructions explain the recommended method to install the air cooled self-contained unit and the electrical wiring connections to the unit.

These instructions and any instructions packaged with any separate equipment required to make up the entire air conditioning system should be carefully read before beginning the installation. Note particularly "Starting Procedure" and any tags and/or labels attached to the equipment.

While these instructions are intended as a general recommended guide, they do not supersede any national and/or local codes in any way. Authorities having jurisdiction should be consulted before the installation is made.

## INSTALLATION

Size of the unit for a proposed installation should be based on heat loss calculation made according to methods of National Warm Air Heating and Air Conditioning Association. The air duct should be installed in accordance with the Standards of the National Fire Protection Association for the Installation of Air Conditioning and Ventilating Systems of Other Than Residence Type, NFPA No. 90A and Residence Type Warm Air Heating and Air Conditioning Systems, NFPA No. 90B. Where local regulations are at a variance with instructions, installer should adhere to local codes.

The unit casing itself is suitable for "0" inch clearance, but the first two feet of supply air duct requires one inch clearance to combustible material.

\*\*\*\*\*

**WARNING:** Failure to provide the one inch clearance for the first two feet between the supply duct and a combustible surface can result in fire.

\*\*\*\*\*

## DUCTWORK

Design the ductwork according to methods given by the National Warm Air Heating and Air Conditioning Association. When duct runs through unheated spaces, it should be insulated with a minimum of one inch of insulation. Use insulation with a vapor barrier on the outside of the insulation. Flexible joints should be used to connect the duct work to the equipment in order to keep the noise transmission to a minimum.

## LOCATING THE UNIT

A location on the roof must be chosen that will provide adequate support to the unit, while at the same time allowing clearance for the supply air and return air duct connections to the RA4260 roof adapter (see layout and dimensions). **NOTE:** The RA4260 roof adapter **MUST BE USED** to assure a leak-free installation and the UL approval is contingent upon the use of this mating adapter.

## ROOF CURB FABRICATION

The roof curb (extension section between actual roof and RA4260 roof adapter) could be fabricated from either sheet steel or nominal dimensional lumber. In either case, the OD dimension of the extension section must be sized to fit the RA4260 adapter dimensions as shown.

All corners, seams or joints must be sealed to assure a leak-free installation. The height of the curb section is determined by installation requirements such as degree slope of roof, direction that the outdoor (exposed) coil faces, and geographic location. The unit **MUST SET LEVEL** when installed, and should be high enough to provide proper defrost drainage from outdoor coil during heating cycle.

A suggested design for a wood frame type construction is shown on page 1.

## OPTIONAL ELECTRIC HEATER PACKAGES

The EBSRA series electric heater packages are available as options. Each package comes complete with heaters and controls.

**IMPORTANT:** A separate power entrance is required for the heater package. **DO NOT** attempt to wire a basic unit and a heater package to one power circuit.

## INSTALLATION

Installation of the heat package requires removing the unit blower from its securing slide mount, inserting the heat package into the same mount and reinstalling the unit blower into a similar mount on the heat package. A minimal amount of wiring is required. Refer to the heat package installation instructions for detailed installation information.

### WIRING--MAIN POWER

Refer to the unit rating plate for wire sizing information and maximum fuse or "HACR Type" circuit breaker size. Each unit is marked with a "Minimum Circuit Ampacity." This means that the field wiring used must be sized to carry that amount of current. Refer to the National Electrical Code for complete current carrying capacity data on the various insulation grades of wiring material.

If an optional heater package is installed, a separate power circuit must be added. Refer to the Electrical Information Chart for circuit information. **DO NOT ATTEMPT TO COMBINE A BASIC UNIT AND A HEATER PACKAGE TO ONE POWER SUPPLY CIRCUIT.**

The unit rating plate lists a "Maximum Time Delay Fuse" or "HACR Type" circuit breaker that is to be used with the equipment. The correct size must be used for proper circuit protection and also to assure that there will be no nuisance tripping due to the momentary high starting current of the compressor motor.

### CONDENSATE DRAINAGE

A 3/4" FPT coupling is provided to connect a condensate drain line to and is located on side opposite outdoor coil.

### WIRING--24V CONTROL CIRCUIT

Ten (10) wires should be run from thermostat subbase to the 24V terminal board in the unit. An 18 gauge copper, color-coded thermostat cable is recommended. The connection points are shown on most of the wiring diagrams and are also shown below.

FIGURE 3  
Unit 24V Terminal Board

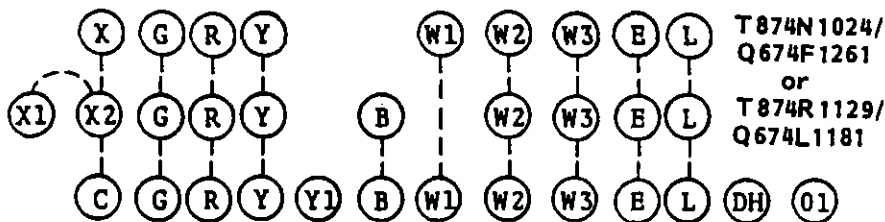

**IMPORTANT NOTE:** Only the thermostat and subbase combinations as shown above will work with this equipment. The thermostat and subbase **MUST** be matched, and correct operation can be assured only by proper selection and application of these parts.

## COMPRESSOR MALFUNCTION RELAY (1-PHASE MODELS ONLY)

Actuation of the green "check" lamp is accomplished by a voltage type relay which is factory installed. Any condition such as loss of charge, defective capacitor, etc., that will prevent compressor from operating will cause green lamp to activate. This is a signal to the operator of the equipment to place system in emergency heat position.

## PRESSURE SERVICE PORTS

High and low pressure service ports are installed on all units so that the system operating pressures can be observed. Pressure charts can be found later in the manual covering all models on both cooling and heating cycles. It is imperative to match the correct pressure chart to the unit by model number.

## THERMOSTAT INDICATOR LAMPS

The red lamp marked "EM HT" comes on and stays on whenever the system switch is placed in the EM HT position. The green lamp marked "check" will come on if there is any problem that prevents the compressor from running when it is supposed to be.

## EMERGENCY HEAT POSITION

The operator of the equipment must manually place the system switch in this position. This is done when there is a known problem with the outdoor section, or when the green "check" lamp comes on indicating a problem.

## COMPRESSOR CUT-OFF THERMOSTAT AND OUTDOOR THERMOSTAT

Heat pump compressor operation at outdoor temperatures below 0 degree F are neither desirable nor advantageous in terms of efficiency. Since most equipment at time of manufacture is not designated for any specific destination of the country, and most of the equipment is installed in areas not approaching the lower outdoor temperature range, the compressor cut-offs are not factory installed.

**NOTE:** Maximum amount of electric heat which can be operated in conjunction with the compressor during heating mode is 15KW single and three phase. The balance of the electric heat can be operated only during the compressor cut off or emergency heat mode.

FIGURE 4

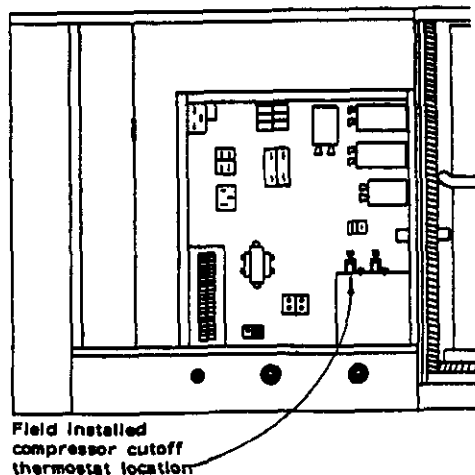

## COMPRESSOR CUT-OFF AND OUTDOOR THERMOSTAT WIRING

FIGURE 5

Unit 24V Terminal Board

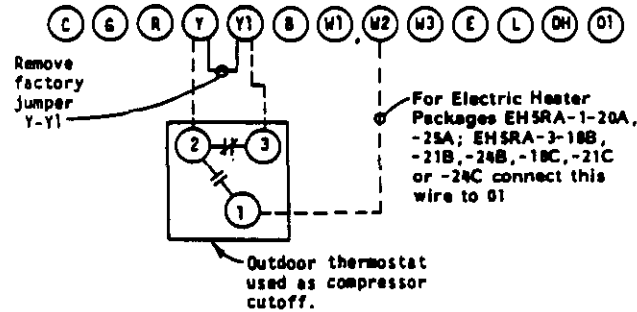

## HEAT ANTICIPATION

Both of the thermostats shown below have a fixed heat anticipator for stage 1 with no adjustment required. Stage 2 has an adjustable anticipator for the W2 connection and fixed for the W3 connection. Both the W2 and W3 circuits are controlled by the stage 2 bulb. The only heat anticipator that needs to be checked is stage 2 and it should be set to match the load carried by the W2 circuit. If special field wiring is done, it is best to actually measure the load but a good rule is .40A for EACH heat contactor controlled by W2.

TABLE 5

WALL THERMOSTAT AND SUBBASE COMBINATIONS			
Group	Thermostat	Subbase	Predominant Feature
A	8403-017 (T874R1129)	8404-009 (Q674L1181)	Heat or Cool ① No Auto
B	8403-018 (T874N1024)	8404-010 (Q674F1261)	Automatic Heat-Cool ② Changeover Position

① No automatic changeover position--must manually place in heat or cool. Reversing valve remains energized at all times system switch is in heat position (except during defrost cycle). No pressure equalization noise when thermostat is satisfied on either heating or cooling.

② Allows thermostat to control both heating and cooling operation when set in "AUTO" position. Reversing valve de-energizes at end of each "ON" heating cycle.

**IMPORTANT NOTE:** Both thermostat and subbase combinations shown above incorporate the following features: Man-Auto fan switch, Off-Heat-Cool-Em. Heat Switch, and two (2) indicator lamps--one for emergency heat and one for compressor malfunction.

## SEQUENCE OF OPERATION

**COOLING**--Circuit R-Y makes at thermostat pulling in compressor contactor starting the compressor and outdoor motor. The G (indoor motor) circuit is automatically completed on any call for cooling operation, or can be energized by manual fan switch on subbase for constant air circulation.

**HEATING**--A 24V solenoid coil on reversing valve controls heating cycle operation. Two thermostat options, one allowing "Auto" changeover from cycle to cycle and the other constantly energizing solenoid coil during heating season and thus eliminating pressure equalization noise except during defrost, are to be used. On "Auto" option, a circuit is completed from R-W1 and R-Y on each heating "on" cycle, energizing reversing valve solenoid and pulling in compressor contactor starting compressor and outdoor motor. R-G also make starting indoor blower motor. Heat pump heating cycle now in operation. The second option has no "Auto" changeover position, but instead energizes the reversing valve solenoid constantly whenever the system switch on subbase is placed in "Heat" position, the "B" terminal being constantly energized from R. A thermostat demand for heat completes R-Y circuit, pulling in compressor contactor starting compressor and outdoor motor. R-G also make starting indoor blower motor.

## CRANKCASE HEATERS

All single and three phase models have an insertion well-type crankcase heater located in the lower section of the compressor housing. This is a self-regulating type heater that draws only enough power to maintain the compressor at a safe temperature.

Crankcase heat is essential to prevent liquid refrigerant from migrating to the compressor, causing oil pump out on compressor start-up and possible valve failure due to compressing a liquid.

The decal in Figure 5 is affixed to all outdoor units detailing start-up procedure. This is very important. Please read carefully.

FIGURE 6

### **IMPORTANT**

**THESE PROCEDURES MUST BE FOLLOWED AT INITIAL START-UP AND AT ANY TIME POWER HAS BEEN REMOVED FOR 12 HOURS OR LONGER.**

**TO PREVENT COMPRESSOR DAMAGE WHICH MAY RESULT FROM THE PRESENCE OF LIQUID REFRIGERANT IN THE COMPRESSOR CRANKCASE**

1. MAKE CERTAIN THE ROOM THERMOSTAT IS IN THE "OFF" POSITION. (THE COMPRESSOR IS NOT TO OPERATE).
2. APPLY POWER BY CLOSING THE SYSTEM DISCONNECT SWITCH. THIS ENERGIZES THE COMPRESSOR HEATER WHICH EVAPORATES THE LIQUID REFRIGERANT IN THE CRANKCASE.
3. ALLOW 4 HOURS OR 60 MINUTES PER POUND OF REFRIGERANT IN THE SYSTEM AS NOTED ON THE UNIT RATING PLATE, WHICHEVER IS GREATER.
4. AFTER PROPERLY ELAPSED TIME THE THERMOSTAT MAY BE SET TO OPERATE THE COMPRESSOR.
5. EXCEPT AS REQUIRED FOR SAFETY WHILE SERVICING -- DO NOT OPEN SYSTEM DISCONNECT SWITCH.

7961-061

## AIR FILTER

Two 16" x 30" x 1" disposable fiberglass type filters are located inside the unit air filtration of both return air from structure and for optional fresh air intake (see below).

Access to the filter is by removing the panel located next to the unit drain connection.

## FRESH AIR INTAKE

The fresh air intake cover is a manual damper operated device to allow intake of fresh air whenever indoor blower is operating. The damper position can be manually set and locked in position with a wing nut. It is held in place by two screws and has a hardware cloth screen to prevent entry of birds or rodents. An optional cover plate is available if fresh air intake is not used.

## DEFROST CYCLE

The defrost cycle is controlled by time and temperature. The 24 volt timer motor runs all the time the compressor is in operation. When the outdoor temperature is in the lower 40 degree F temperature range or colder, the outdoor coil temperature is 32 degrees F or below. This temperature is sensed by the defrost thermostat mounted near the bottom of the outdoor coil on a return bend. The defrost thermostat closes at approximately 32 degrees F. Every 60 (or 30) minutes that the compressor is running, contacts 3 - 5 close for 7 minutes, with contacts 3 - 4 closed for the first 40 seconds of that 7 minutes. If the defrost thermostat is closed, the defrost relay energizes and places the system in defrost mode. An interlocking circuit is created with timer contact 3 - 5 and defrost relay contact 7 - 9 in series.

During the defrost mode, the refrigerant cycle switches back to the cooling cycle, the outdoor motor stops, electric heaters are energized, and hot gas passing through the outdoor coil melts any accumulated frost. When the temperature rises to approximately 57 degrees F, the defrost thermostat opens, de-energizing the defrost relay and returning the system to heating operation.

If some abnormal or temporary condition such as a high wind causes the heat pump to have a prolonged defrost cycle, contacts 3 - 5 of the defrost timer will open after 7 minutes and restore the system to heating operations automatically.

There are two time settings on the defrost timer--30 minutes and 60 minutes. Most models are shipped wired on the 60 minute setting for greatest operating economy. If special circumstances require a change to the shorter time, remove wire connected to terminal 5/60 and reconnect to terminal 5/30.

There is a manual advance knob located on the timer. This can be used to advance timer to contact point if it is desired to check out defrost cycle operation, without waiting for time to elapse.

FIGURE 7  
Defrost Timer Wiring

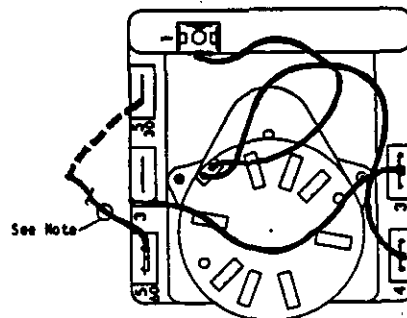

NOTE: All models are connected to 5/60 terminal (60 minute). Any models can be changed from 60 minutes to 30 minutes by unplugging from 5/60 terminal and reconnecting to 5/30 terminal as shown by dotted line.

## REFRIGERANT CHARGE

The correct system R-22 charge is shown on the unit rating plate. Optimum unit performance will occur with a refrigerant charge resulting in a suction line temperature (6" from compressor) as shown in the following table:

TABLE 6

Model	Rated Airflow	°	°
		95 F OD Temperature	82 F OD Temperature
RPMB42	1500	57 - 59	69 - 71
RPMB48	1700	61 - 63	69 - 71
RPMB60	2000	59 - 61	67 - 69

The above suction line temperatures are based upon 80 degrees F dry bulb/67 degrees F wet bulb (50% R.H.) temperature and rated airflow across the evaporator during cooling cycle.

## SERVICE HINTS

1. Caution homeowner to maintain clean air filters at all times. Also not to needlessly close off supply and return air registers. This reduces air flow through the system, which shortens equipment service life as well as increasing operating costs.
2. Switch to heating cycle at 75 degrees F or higher outside temperature may cause a nuisance trip of the manual reset high pressure switch.
3. The heat pump wall thermostats perform multiple functions. Be sure that all function switches are correctly set for the desired operating mode before trying to diagnose any reported service problems.
4. Check all power fuses or circuit breakers to be sure that they are the correct rating.
5. Periodic cleaning of the outdoor coil to permit full and unrestricted airflow circulation is essential.



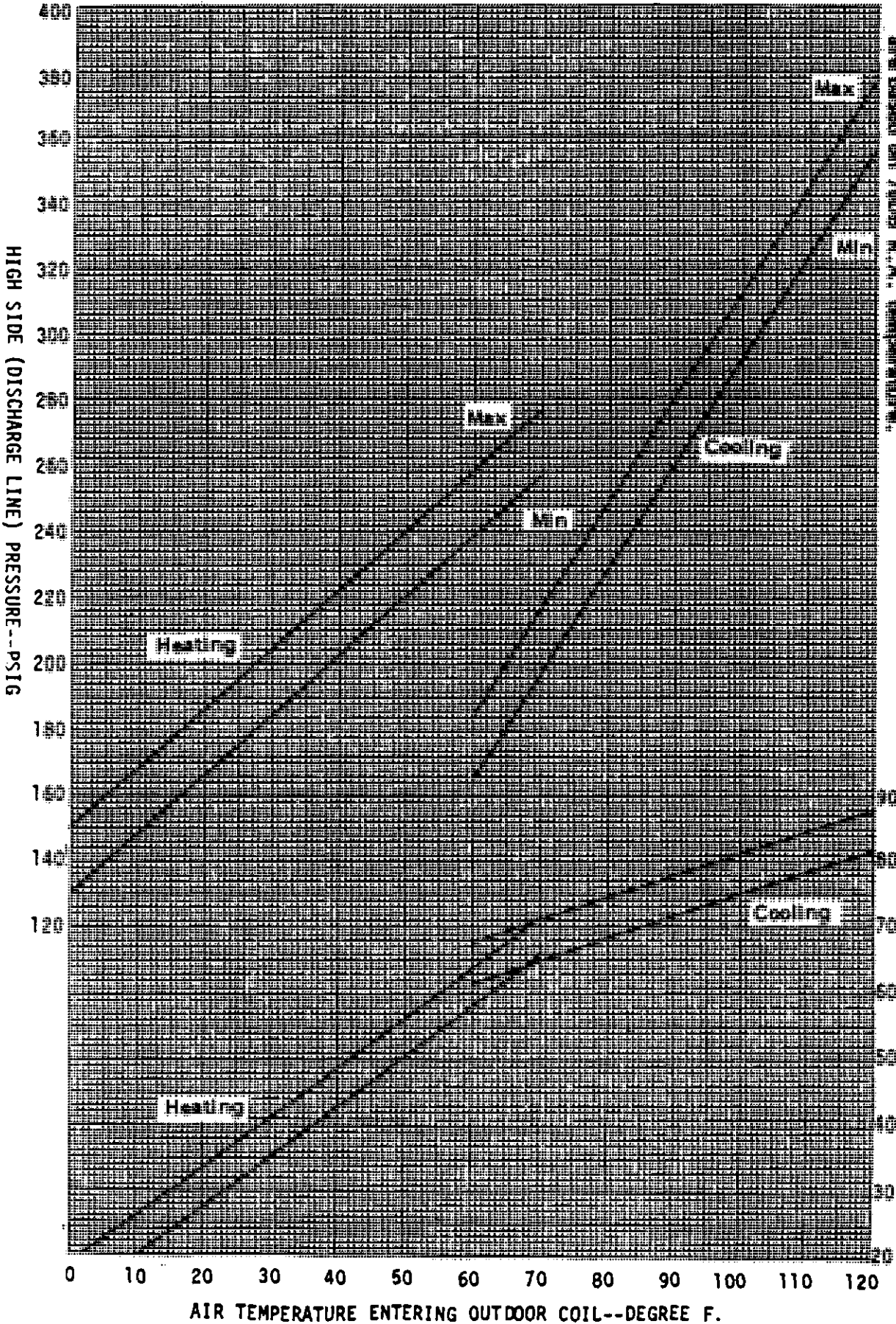

Cooling curves are based upon 80DB, 67WB Temp. and rated CFM (air-flow) across the evaporator coil and should be used for reference purposes only. Specific information can be found under section titled "Refrigerant Charge" elsewhere in manual. If there is any doubt as to correct operating charge being in the system, the charge should be removed, system evacuated, and recharged according to serial plate instructions. Heating curves

LOW SIDE PRESSURE--PSIG  
(SUCTION LINE)

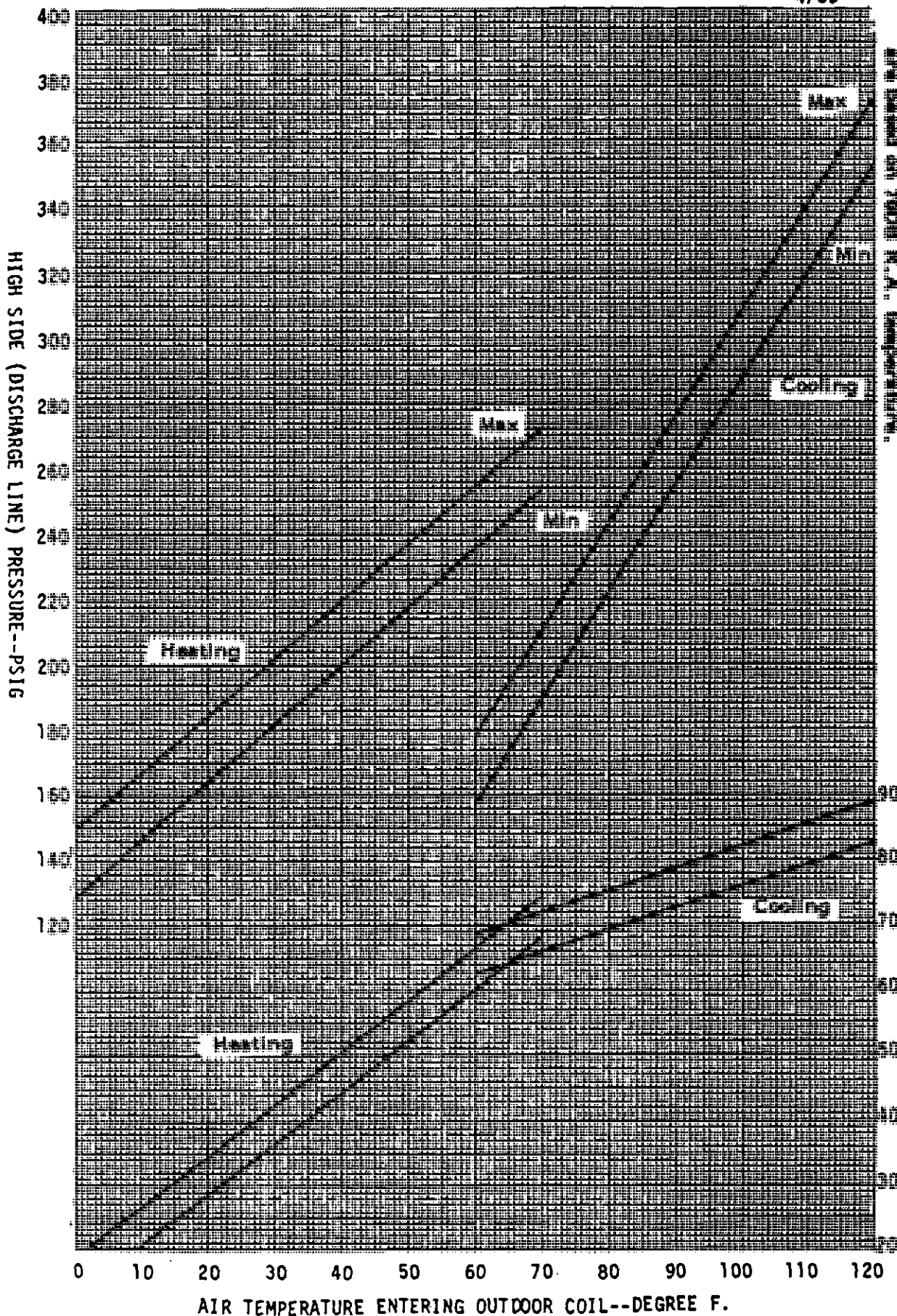

Cooling curves are based upon 80DB, 67WB Temp. and rated CFM (air-flow) across the evaporator coil and should be used for reference purposes only. Specific information can be found under section titled "Refrigerant Charge" elsewhere in manual. If there is any doubt as to correct operating charge being in the system, the charge should be removed, system evacuated, and recharged according to serial plate instructions. Heating curves

LOW SIDE PRESSURE--PSIG  
(SUCTION LINE)

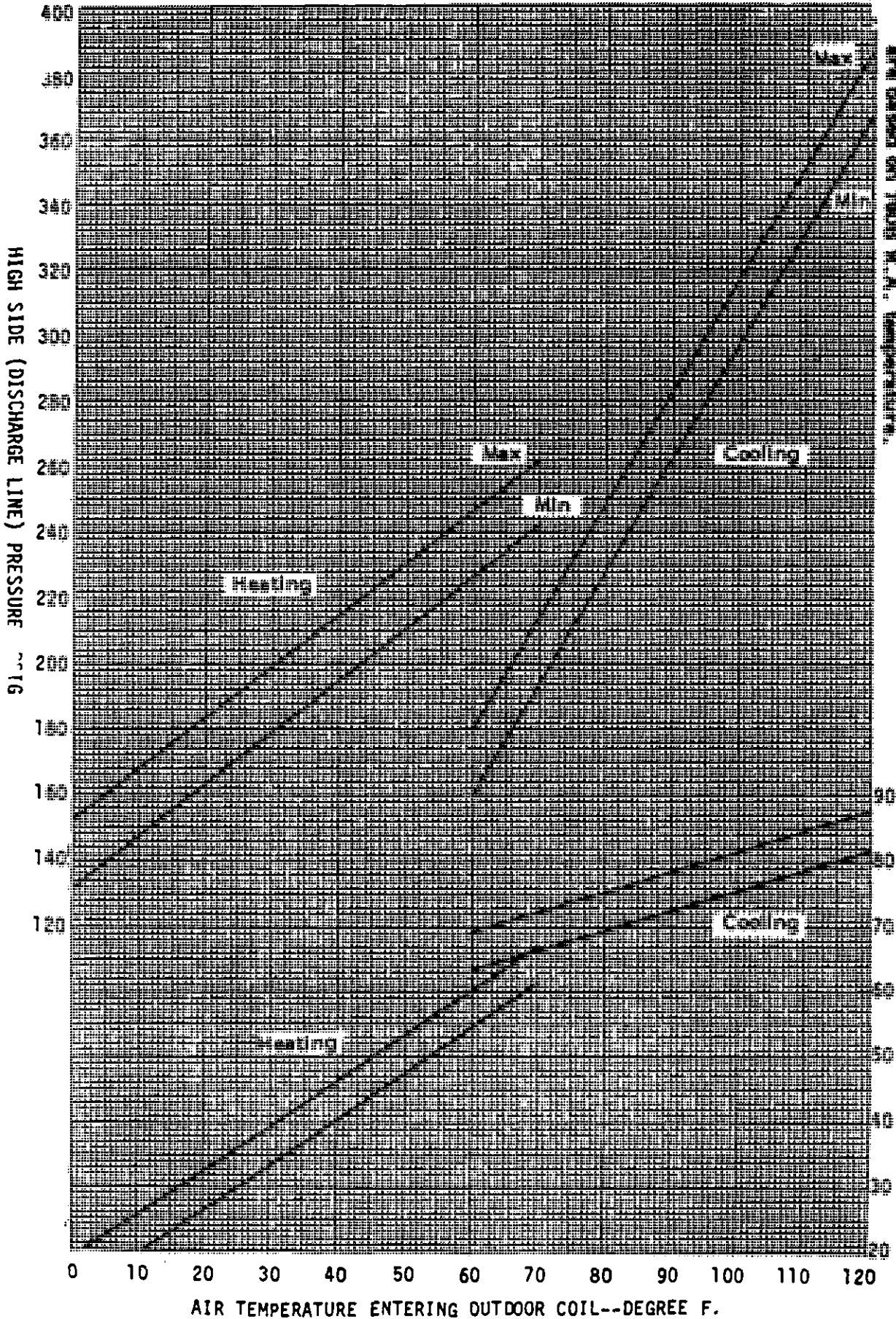

Cooling curves are based upon 80DB, 67WB Temp. and rated CFM (air-flow) across the evaporator coil and should be used for reference purposes only. Specific information can be found under section titled "Refrigerant Charge" elsewhere in manual. If there is any doubt as to correct operating charge being in the system, the charge should be removed, system evacuated, and recharged according to serial plate instructions. Heating curves

LOW SIDE PRESSURE--PSIG  
(SUCTION LINE)

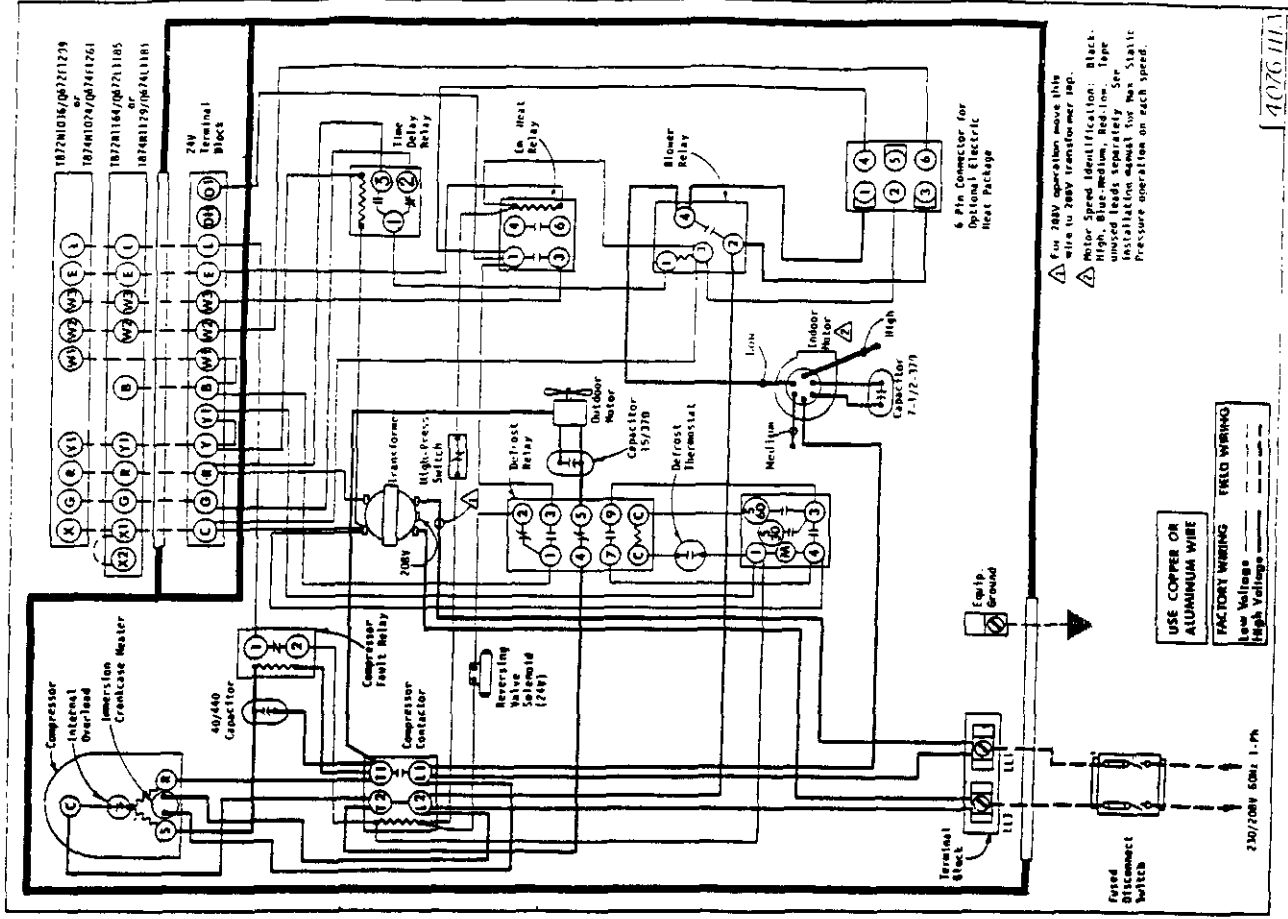
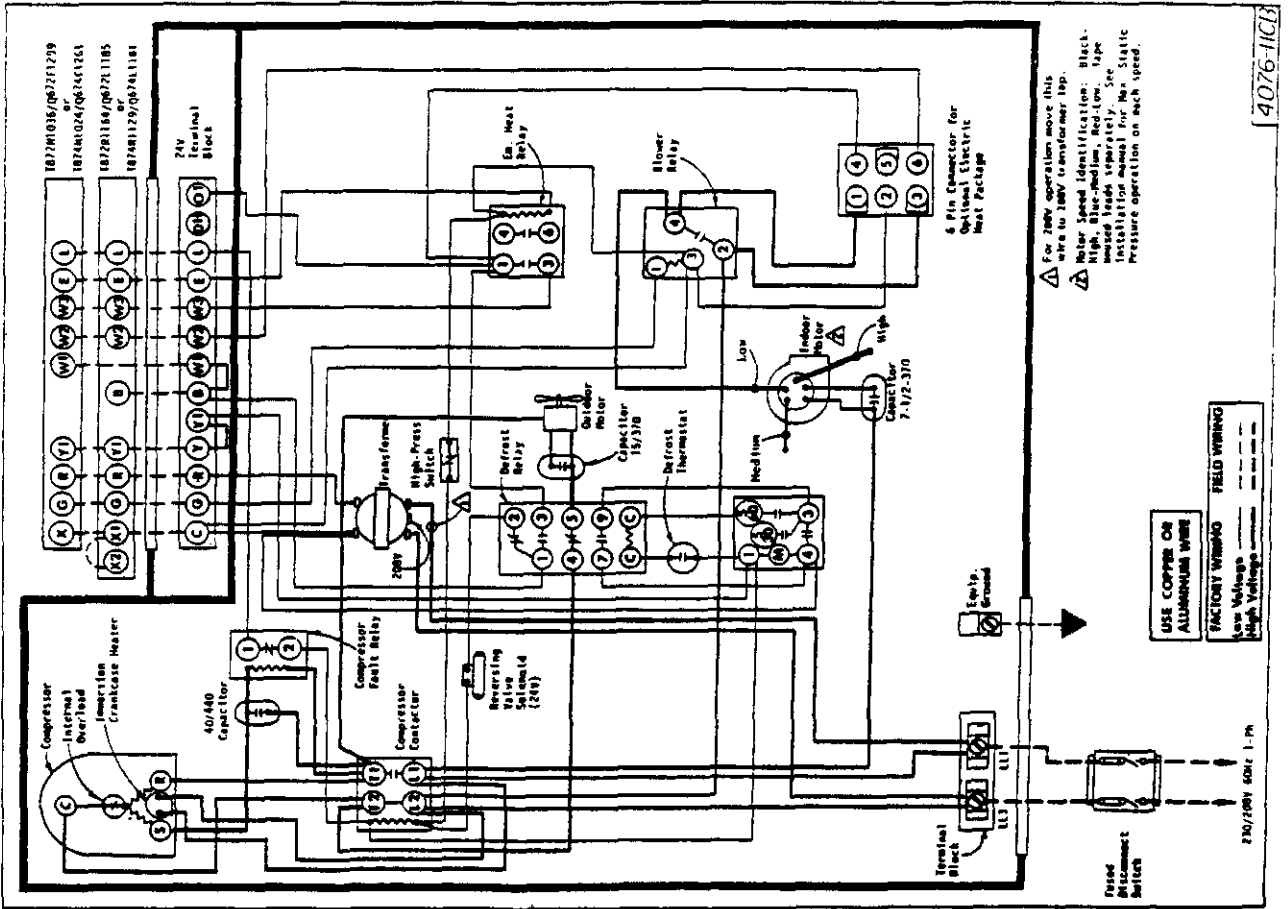

For 200V operation move this wire to 200V transformer tap.

Motor Speed Identification: Black, High, Blue-Medium, Red-Low. See installation manual for Max. Static Pressure operation on each speed.

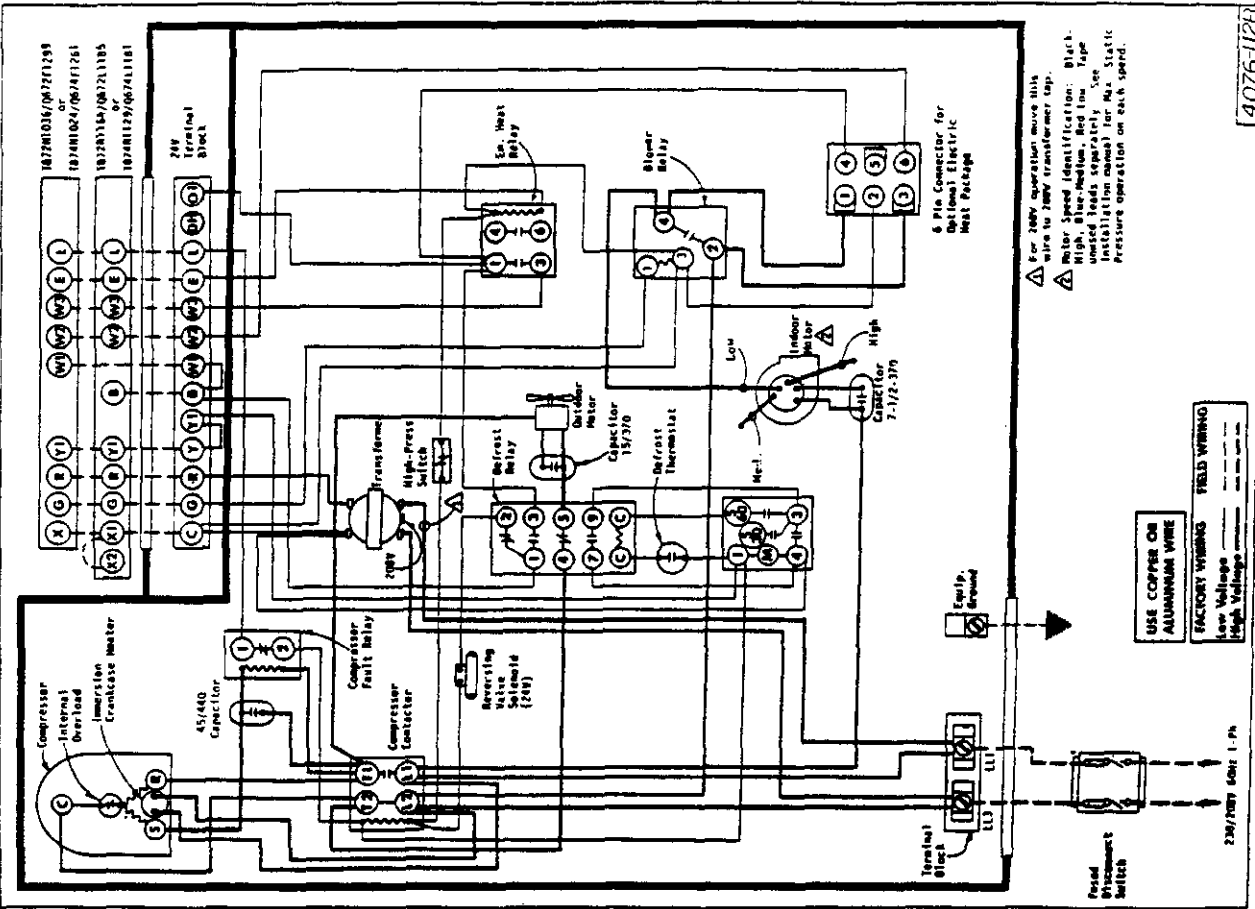
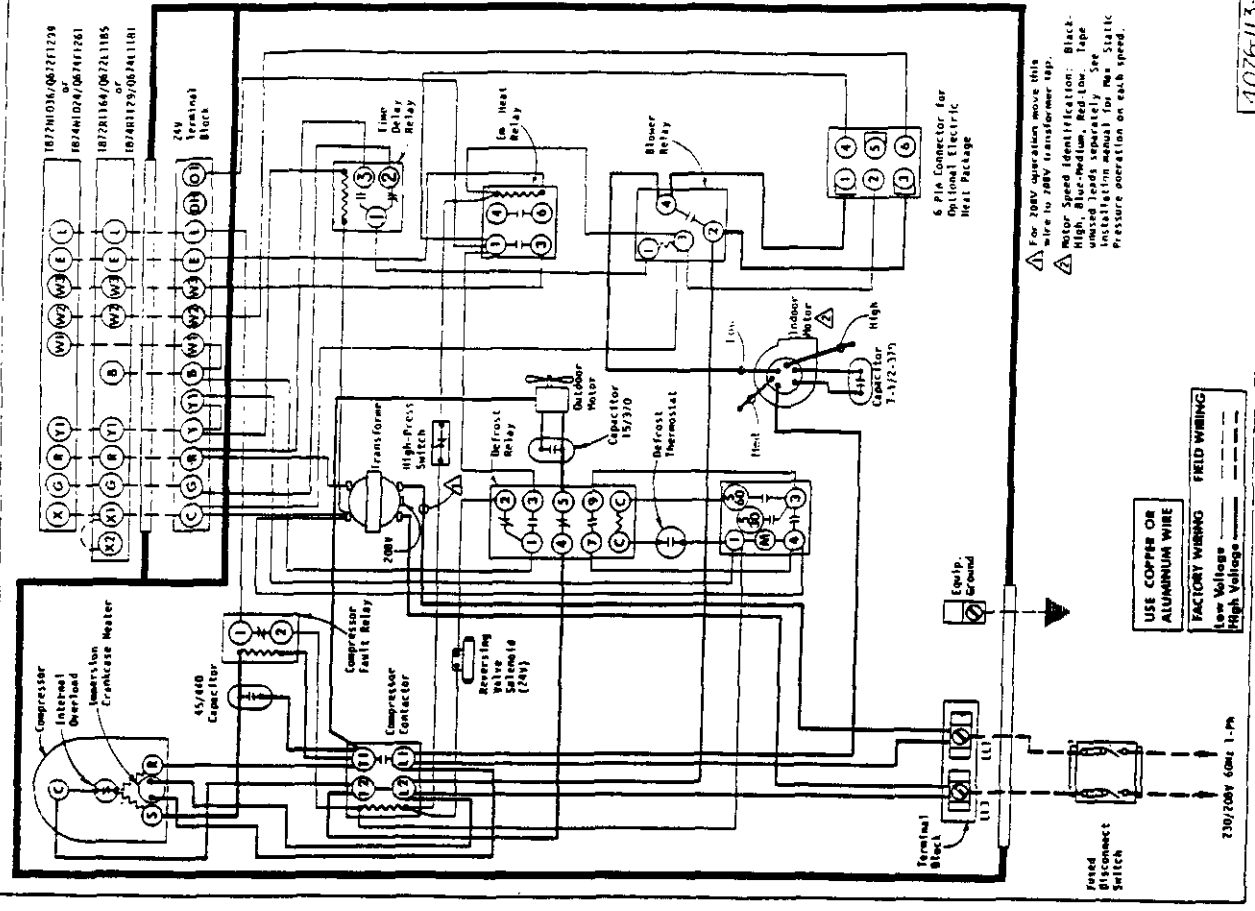



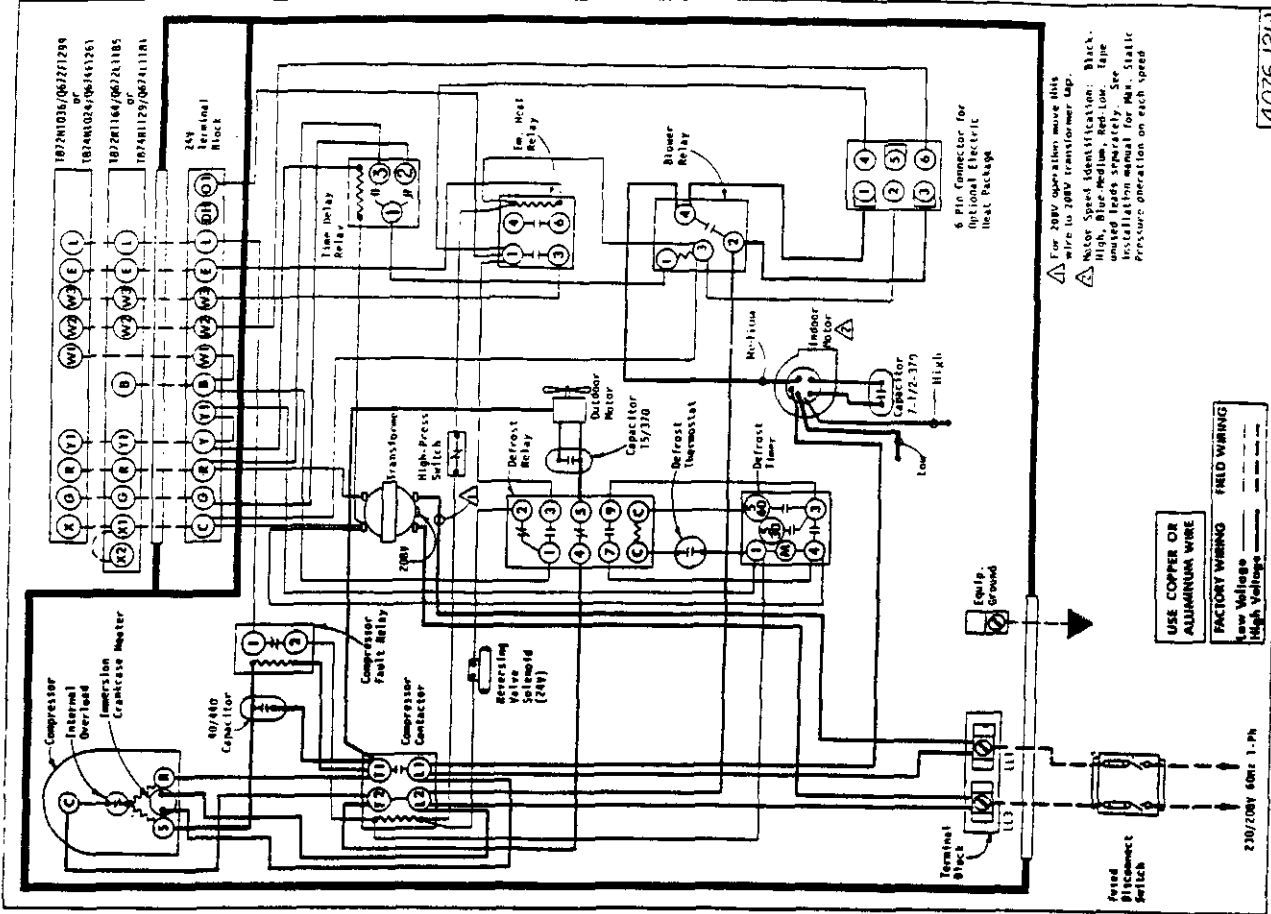
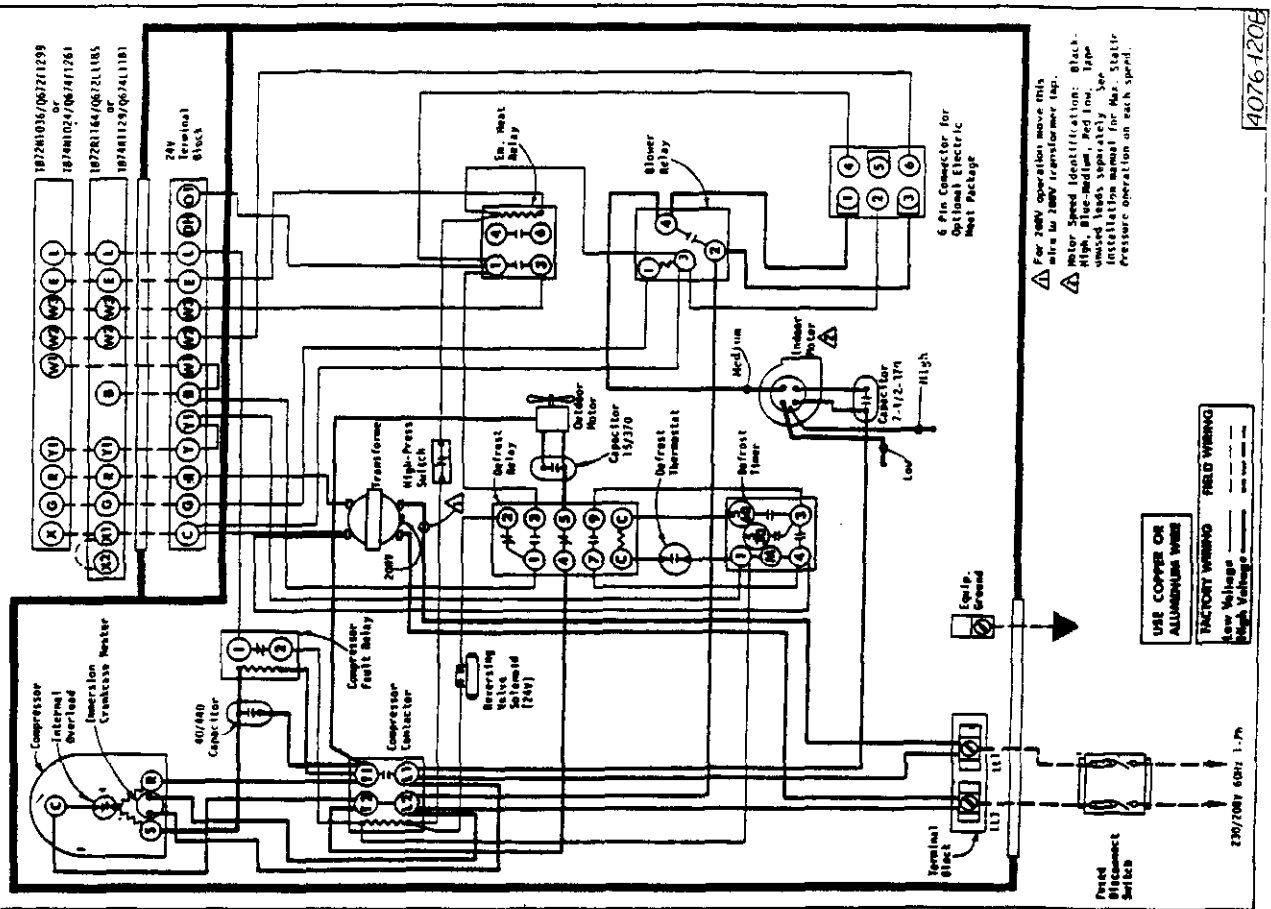

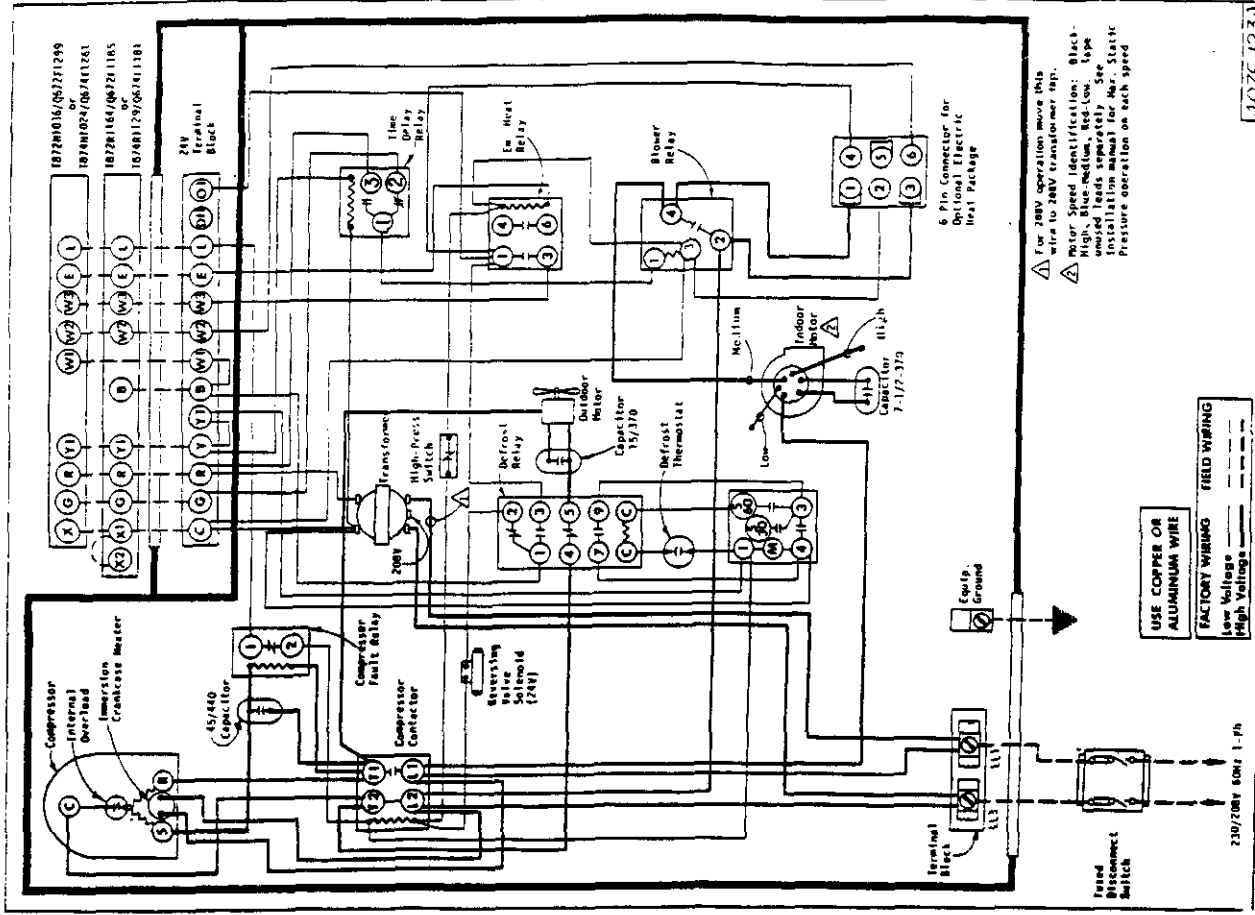
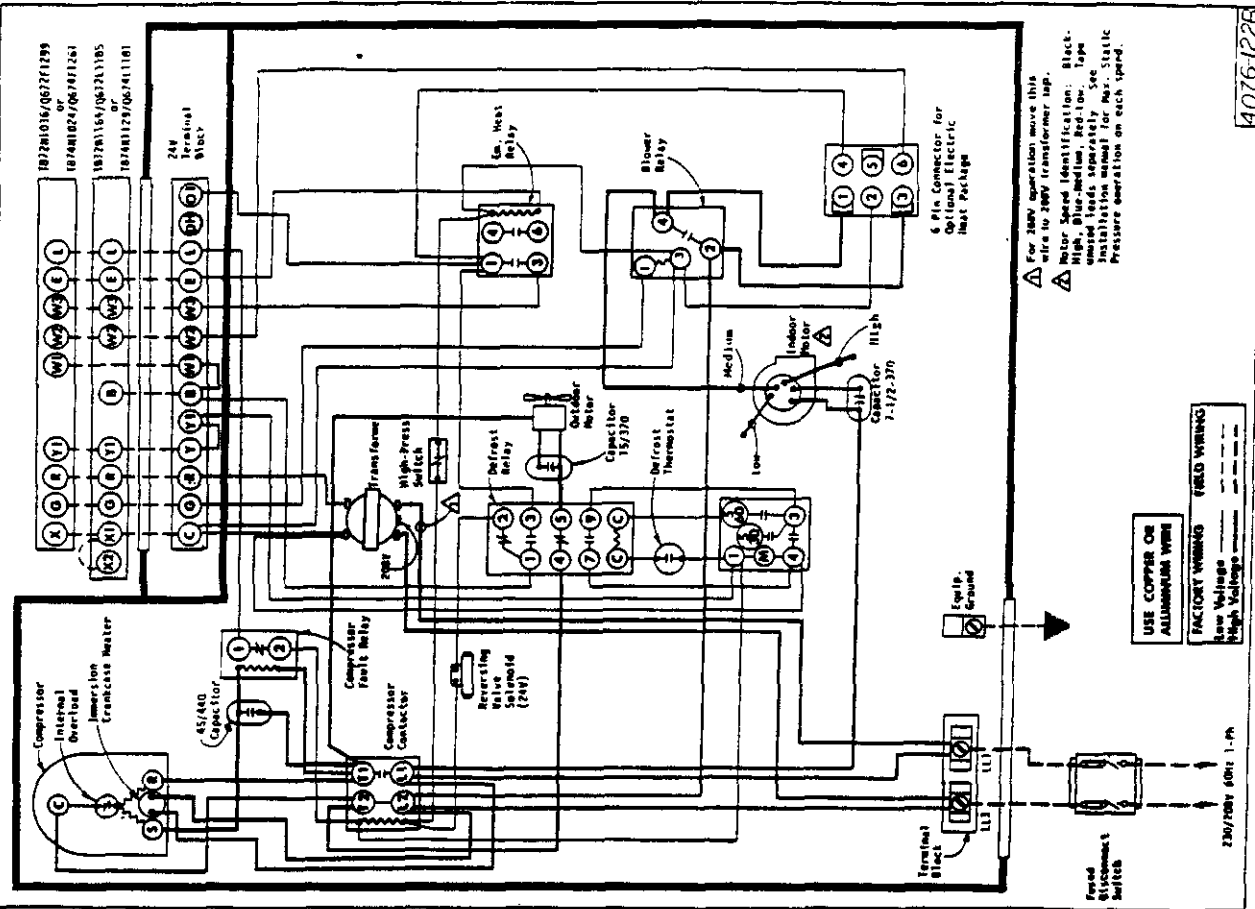

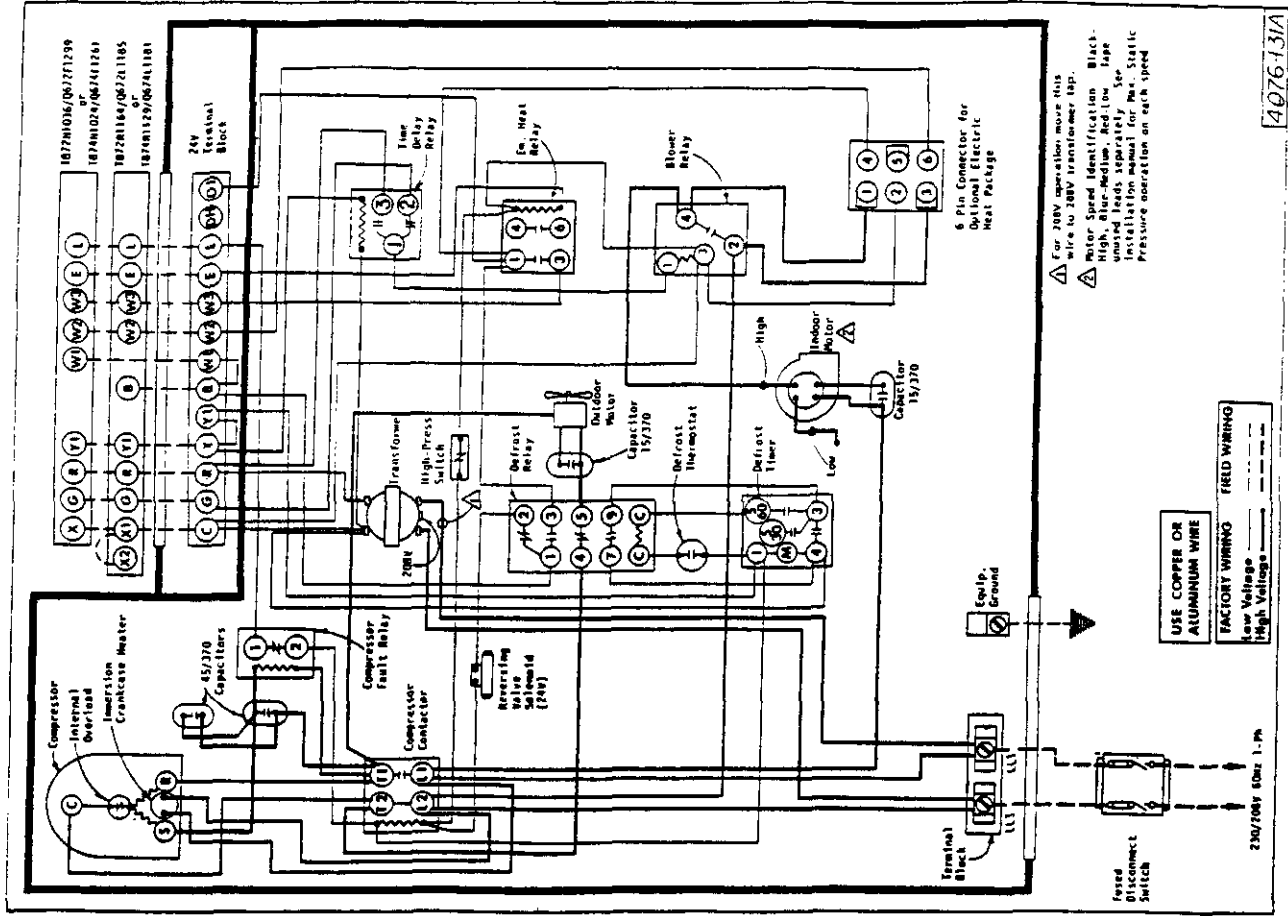
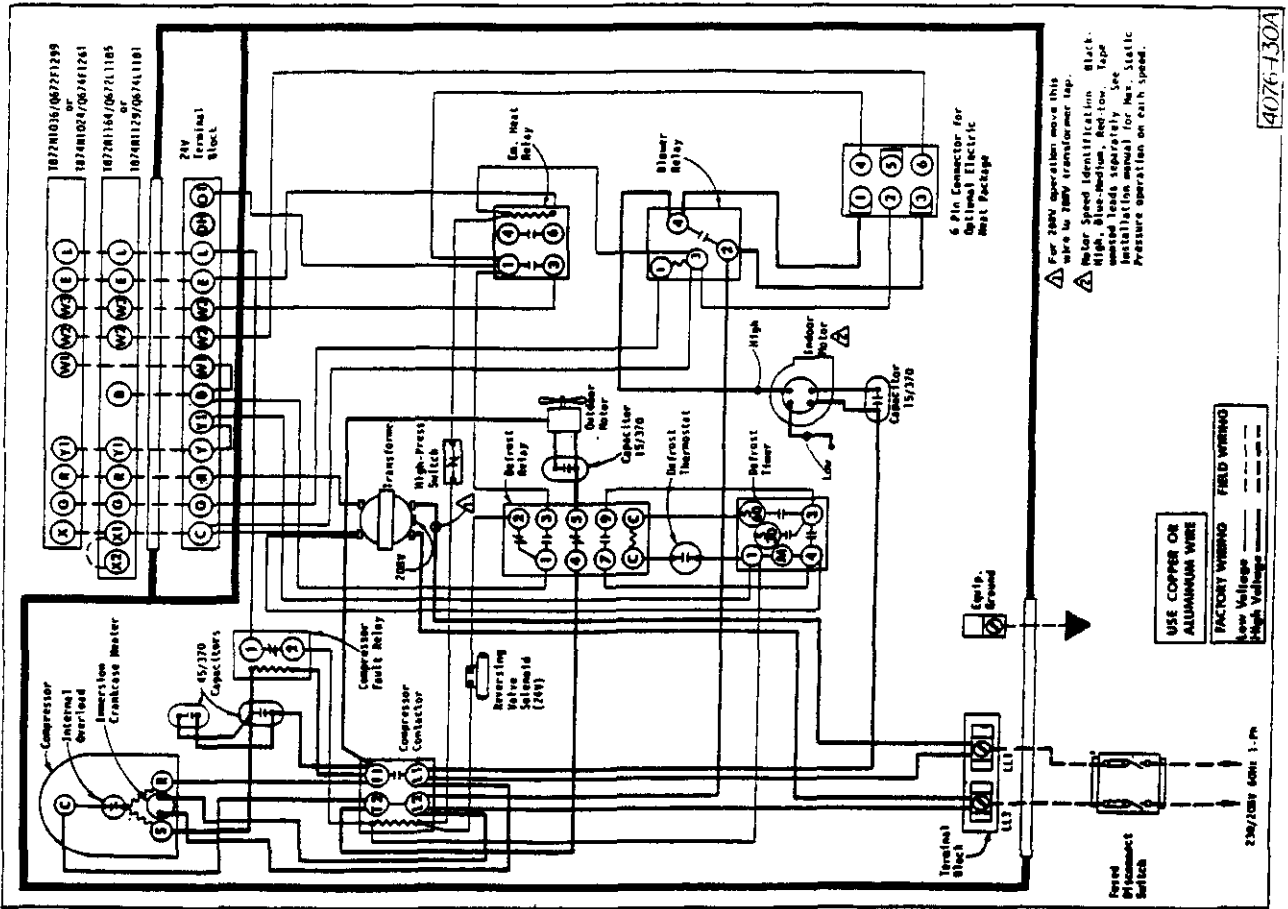

For 208V operation move this wire to 208V transformer tap.  
Motor Speed Identification: Black - High, Blue-Medium, Red-Low. Tap unused leads separately. See installation manual for Max. Static Pressure operation on each speed.



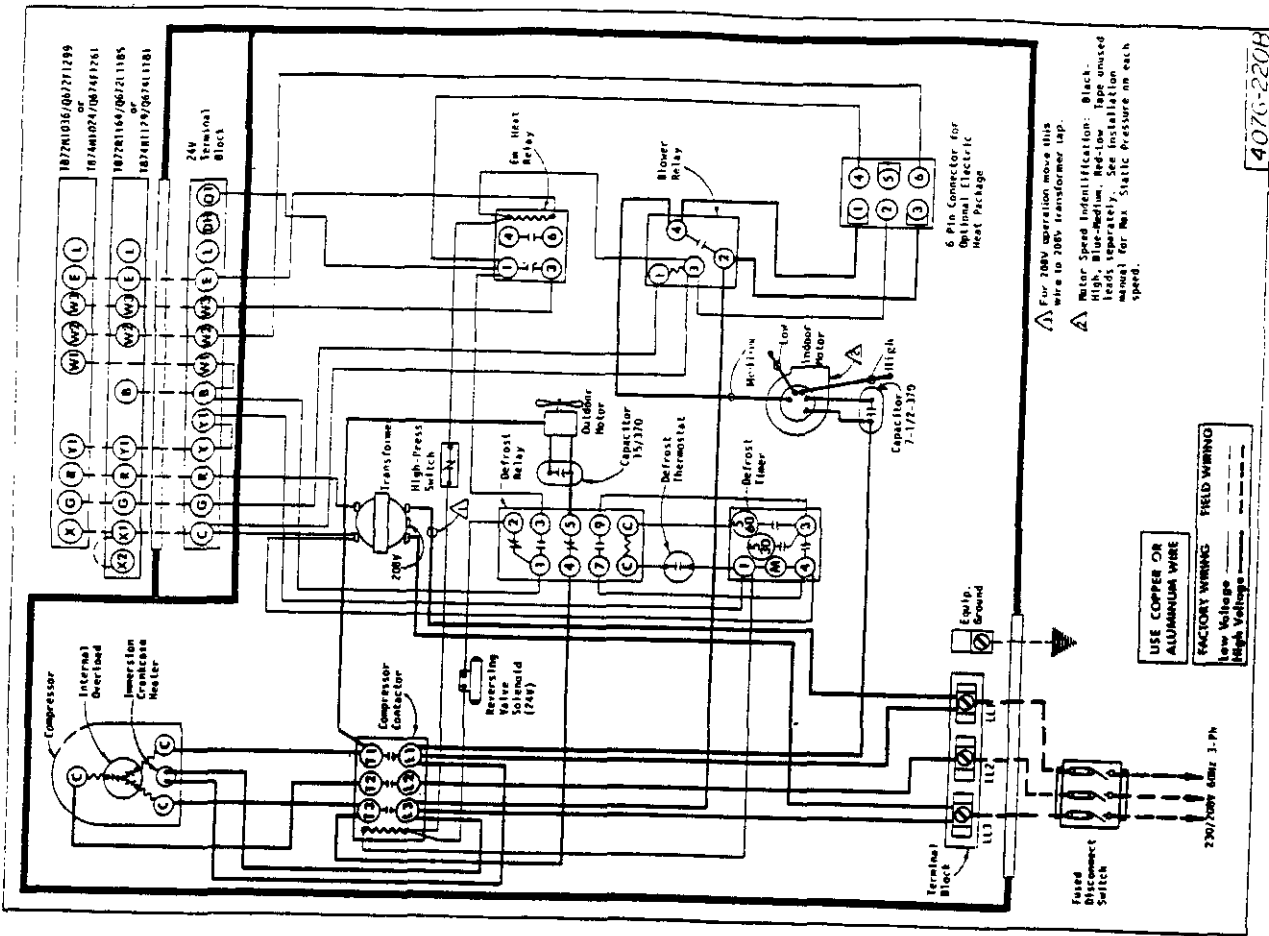
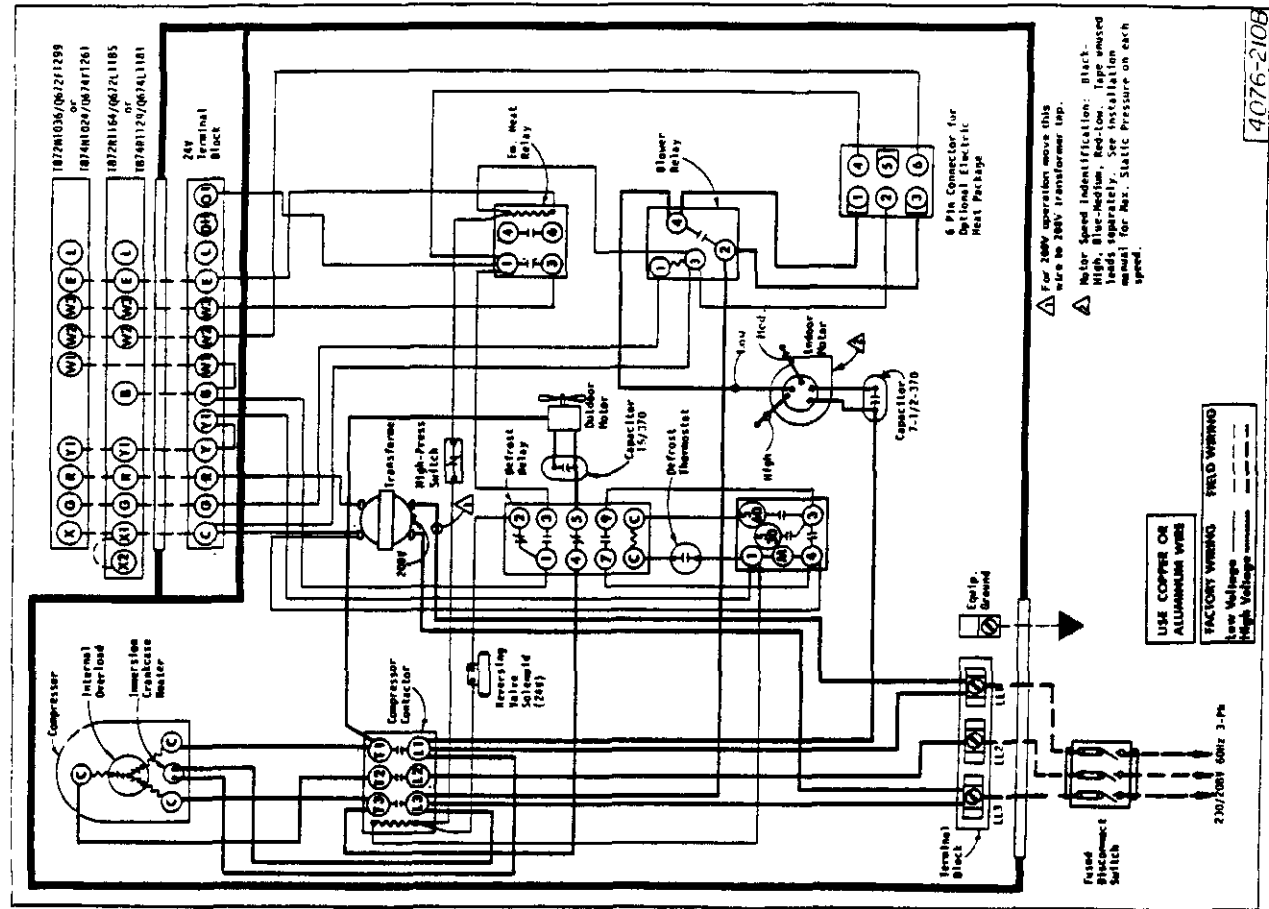

- ⚠ For 208V operation move this wire to 208V transformer tap.
- ⚠ Motor Speed Identification: Black, High, Blue-Medium, Red-Low. Tape amusec leads, separately. See installation manual for Max. Static Pressure on each speed.

- ⚠ For 208V operation move this wire to 208V transformer tap.
- ⚠ Motor Speed Identification: Black, High, Blue-Medium, Red-Low. Tape amusec leads, separately. See installation manual for Max. Static Pressure on each speed.

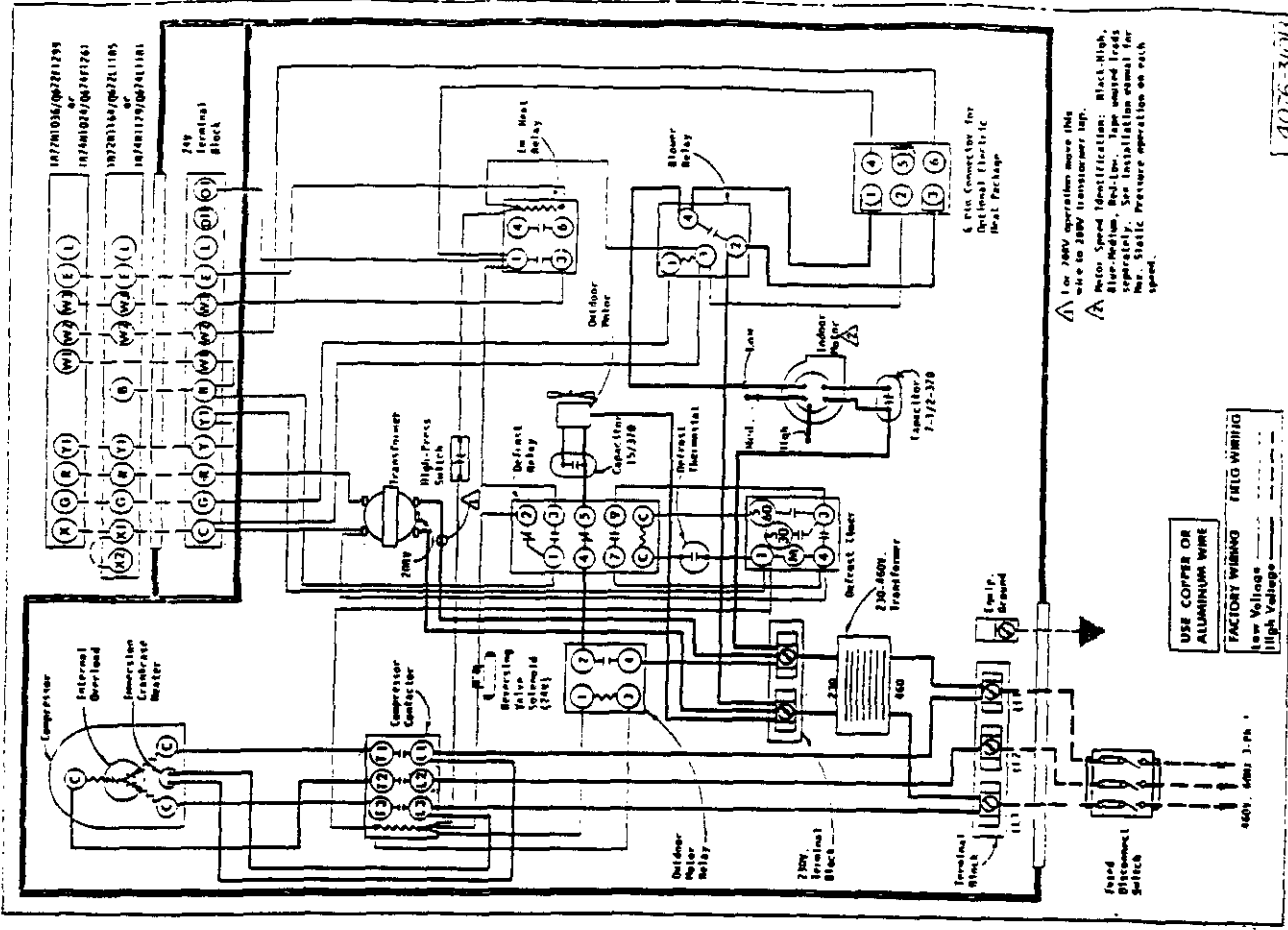
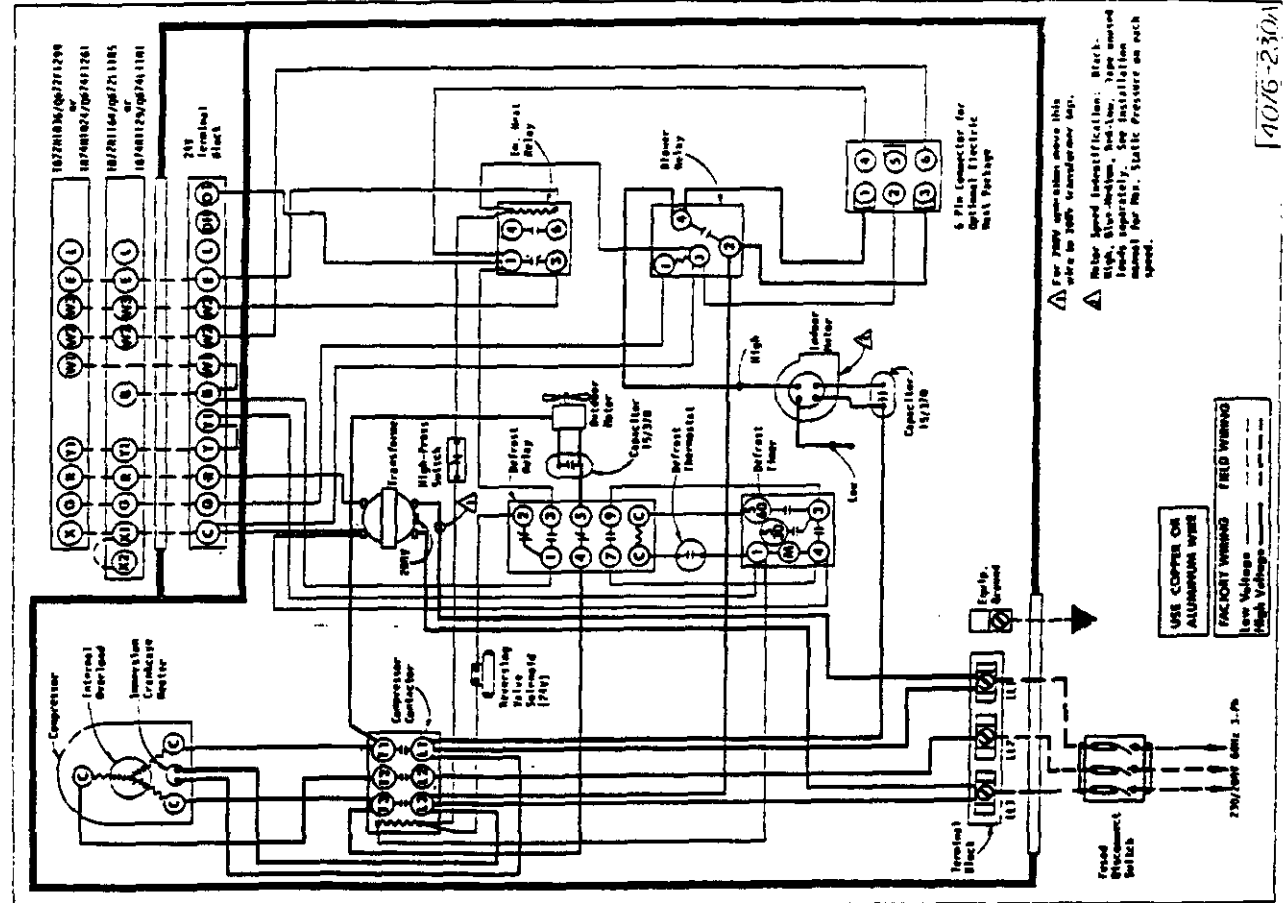

For 208V operation move this wire to 208V transformer tap.

Motor Speed Identification: Black-High, Blue-Medium, Red-Low. Tap wires used separately. See installation manual for motor static pressure operation on each speed.

For 208V operation move this wire to 208V transformer tap.

Motor Speed Identification: Black-High, Blue-Medium, Red-Low. Tap wires used separately. See installation manual for motor static pressure operation on each speed.



