

MODELS
RPMA 42, RPMA 48, RPMA 60
ROOF MOUNT
PACKAGED AIR CONDITIONER
INSTALLATION INSTRUCTIONS

SPECIALLY DESIGNED FOR ROOFTOP
HEATING / COOLING APPLICATIONS

Easy 3-step installation for roof top applications. Saves installation labor, time, cost and provides leakproof installation. No special roof hood plenum assembly required.

RPMA 42, RPMA 48, RPMA 60
Packaged Roof Mount
Air Conditioner

RA260 ROOF ADAPTER.
Painted galvanized steel
adapter permits installer to
rough-in the duct work at
the job site and install RPM
unit later. (Duct flanges
provided on bottom of roof
adapter). Special one piece
leakproof design.

(OPTIONAL)
9042-001 ROOF CURB
Leakproof, knockdown,
galvanized construction
with roofing nailer strip
- suitable for all flat
roofs.

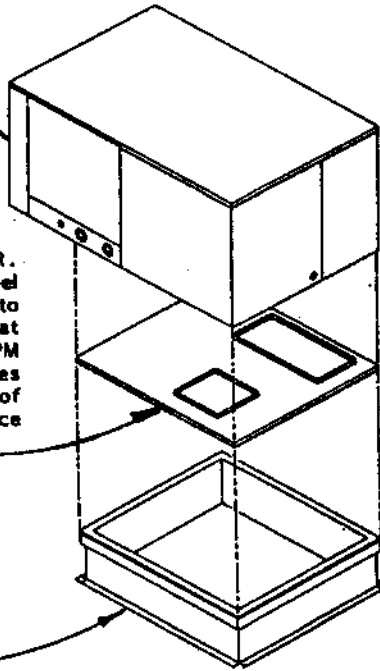

**TYPICAL CONSTRUCTION FOR
DIMENSIONAL LUMBER
EXTENSION CONSTRUCTION**

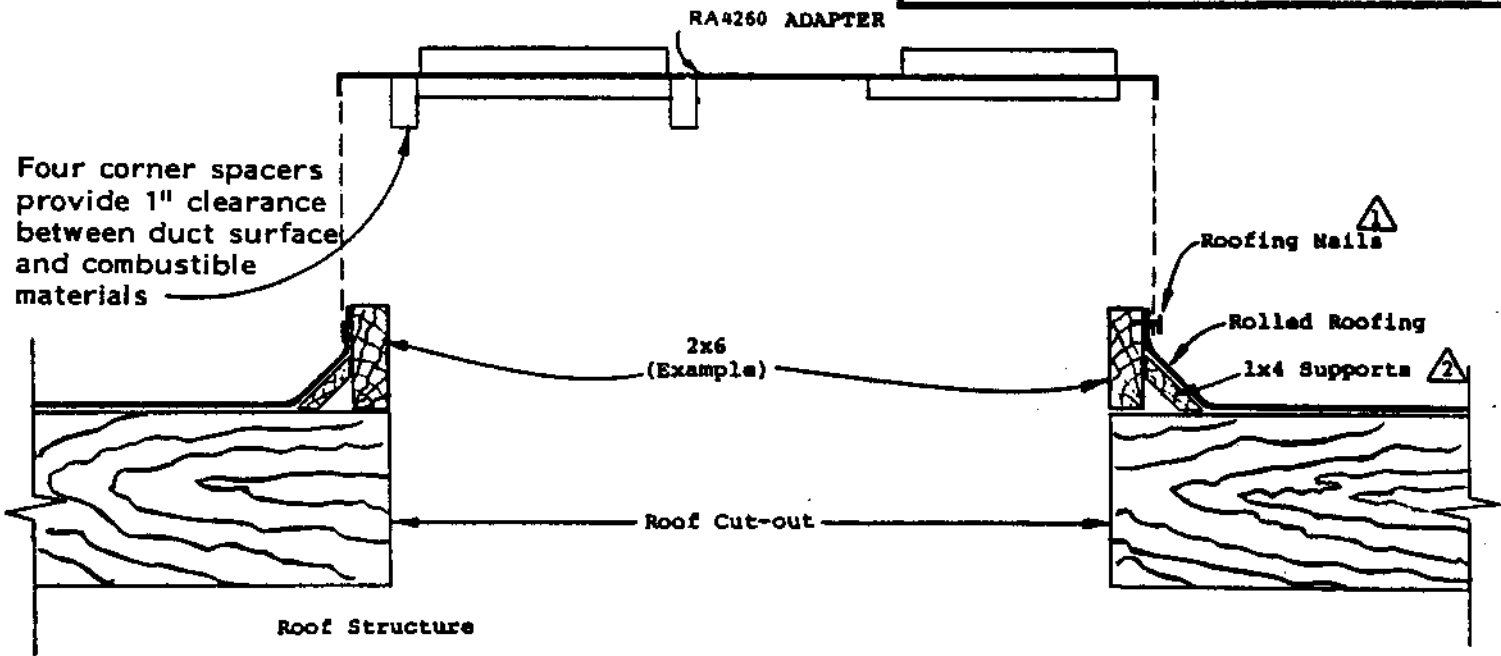
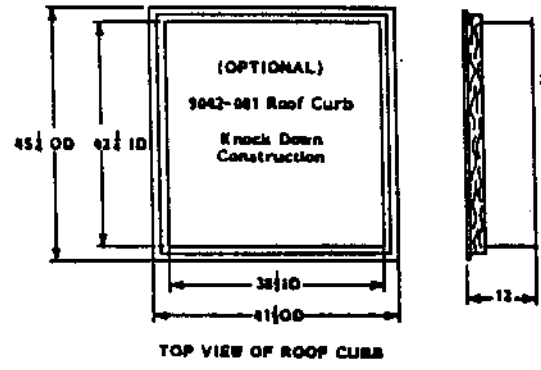
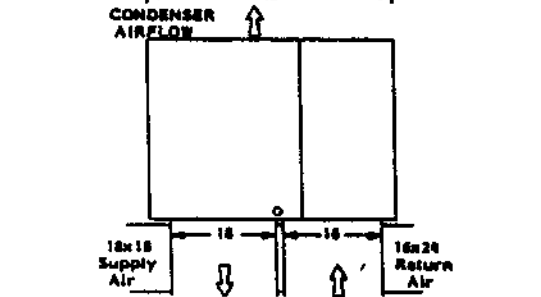
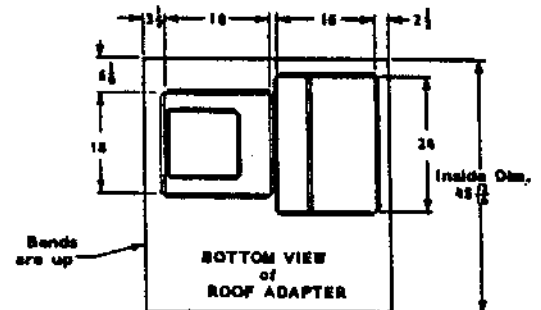

- ⚠ Nail 3/4" from top.
- ⚠ Provides support to roofing material, prevents sharp bends and cracking.

IMPORTANT

The equipment covered in this manual is to be installed by trained, experienced service and installation technicians. Any heat pump is more critical of proper operating, charge and an adequate duct system than a straight air conditioning unit. All ductwork, supply and return, must be properly sized for the design air flow requirement of the equipment. Air Conditioning Contractors of America (ACCA) is an excellent guide to proper sizing. All ductwork or portions thereof not in the conditioned space should be properly insulated in order to both conserve energy and prevent condensation or moisture damage.

SHIPPING DAMAGE

Upon receipt of equipment, the carton should be checked for external signs of shipping damage. If damage is found, the receiving party must contact the last carrier immediately, preferably in writing, requesting inspection by the carrier's agent.

UNPACKING THE SELF-CONTAINED UNIT

It is recommended that the unit be unpacked at the installation site to minimize damage due to handling.

1. Cut and remove the metal band from around unit.
2. Remove the carton from the unit.
3. The installation manual is contained in an envelope shipped with the unit. Make sure that it does not get lost.
4. Carefully block up the unit and remove the shipping skid.
5. CAUTION - DO NOT tip the unit on its side. Oil may enter the compressor cylinders and cause starting or operating trouble. If unit has sat on its side, restore to upright position and do not run for several hours. Also run intermittently for a few seconds. Do this three or four times with three minutes in between. Observe abnormal compressor noise.

GENERAL

The refrigerant system is completely assembled and charged. All internal wiring is complete.

These instructions explain the recommended method to install the air cooled self-contained unit and the electrical wiring connections to the unit.

These instructions and any instructions packaged with any separate equipment required to make up the entire air conditioning system should be carefully read before beginning the installation. Note particularly "Starting Procedure" and any tags and/or labels attached to the equipment.

While these instructions are intended as a general recommended guide, they do not supersede any national and/or local codes in any way. Authorities having jurisdiction should be consulted before the installation is made.

INSTALLATION

Size of the unit for a proposed installation should be based on heat loss calculation made according to methods of National Warm Air Heating and Air Conditioning Association. The air duct should be installed in accordance with the Standards of the National Fire Protection Association for the Installation of Air Conditioning and Ventilating Systems of Other Than Residence Type, NFPA No. 90A, and Residence Type Warm Air Heating and Air Conditioning Systems, NFPA No. 90B. Where local regulations are at a variance with instructions, installer should adhere to local codes.

UNIT LIFTING BRACKETS

Four lifting brackets with fasteners are supplied with the basic unit. These brackets are inserted next to the unit control panel. Access to these brackets is gained by removing the outer control panel cover. These brackets can be installed using the mating holes along the unit base.

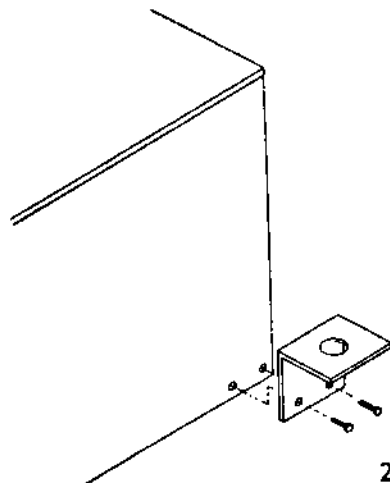

DUCTWORK

Design the ductwork according to methods given by the National Warm Air Heating and Air Conditioning Association. When duct runs through unheated spaces, it should be insulated with a minimum of one inch of insulation. Use insulation with a vapor barrier on the outside of the insulation. Flexible joints should be used to connect the duct work to the equipment in order to keep the noise transmission to a minimum.

LOCATING THE UNIT

A location on the roof must be chosen that will provide adequate support to the unit, while at the same time allowing clearance for the supply air and return air duct connections to the RA4260 roof adapter (see layout and dimensions). NOTE: The RA4260 roof adapter **MUST BE USED** to assure a leak-free installation and the UL approval is contingent upon the use of this mating adapter.

ROOF CURB FABRICATION

The roof curb (extension section between actual roof and RA4260 roof adapter) could be fabricated from either sheet steel or nominal dimensional lumber. In either case, the OD dimension of the extension section must be sized to fit the RA4260 adapter dimensions as shown.

All corners, seams or joints must be sealed to assure a leak-free installation. The height of the curb section is determined by installation requirements such as degree slope of roof, direction that the outdoor (exposed) coil faces, and geographic location. The unit **MUST SET LEVEL** when installed, and should be high enough to provide proper defrost drainage from outdoor coil during heating cycle.

A suggested design for a wood frame type construction is shown on page 1.

OPTIONAL ELECTRIC HEATER PACKAGES

The EHSRA-Series electric heater packages are available as options. Each package comes complete with heaters and controls.

IMPORTANT: A separate power entrance is required for the heater package. DO NOT attempt to wire a basic unit and a heater package to one power circuit.

INSTALLATION

Installation of the heat package requires removing the unit blower from its securing slide mount, inserting the heat package into the same mount and reinstalling the unit blower into a similar mount on the heat package. A minimal amount of wiring is required. Refer to the heat package installation instructions for detailed installation information.

WIRING - MAIN POWER

Refer to the unit rating plate for wire sizing information and maximum fuse or "HACR Type" circuit breaker size. Each unit is marked with a "Minimum Circuit Ampacity." This means that the field wiring used must be sized to carry that amount of current. Refer to the National Electrical Code for complete current carrying capacity data on the various insulation grades of wiring material.

If an optional heater package is installed, a separate power circuit must be added. Refer to the Electrical Information Chart for circuit information. **DO NOT ATTEMPT TO COMBINE A BASIC UNIT AND A HEATER PACKAGE TO ONE POWER SUPPLY CIRCUIT.**

The unit rating plate lists a "Maximum Time Delay Fuse" or "HACR Type" circuit breaker that is to be used with the equipment. The correct size must be used for proper circuit protection and also to assure that there will be no nuisance tripping due to the momentary high starting current of the compressor motor.

CONDENSATE DRAINAGE

A 3/4" FPT coupling is provided to connect a condensate drain line to, and is located on side opposite outdoor coil.

INDOOR BLOWER PERFORMANCE CFM - Dry Coil With Filter								
E.S.P. in H ₂ O	RPMA 42			RPMA 48			RPMA 60	
	High Speed	Medium Speed	Low Speed	High Speed	Medium Speed	Low Speed	High Speed	Low Speed
.0	1995	1920	1775	2160	2075	1860	2250	2100
.10	1935	1870	1735	2080	1980	1810	2180	2045
.20	1865	1800	1670	1995	1920	1735	2100	1975
.30	1770	1700	1600	1910	1840	1670	2020	1910
.40	1680	1610	1525	1820	1745	1590	1925	1840
.50	1580	1525	1430	1715	1650	1510	1845	1750
.60	1480	1420	1340	1615	1550	1420	1740	1660

BASIC UNIT ELECTRICAL DATA							
Model	Rated Volts & Ph	Operating Voltage Range	Max. Unit Amps 230/208	Maximum Fuse or Circuit Breaker*	Minimum Circuit Ampacity	Field** Power Wiring	Ground Wire ** Size
				Ckt. A	Ckt. A	Ckt. A	Ckt. A
RPMA 42	230/208-1	197-253	24/26	50	34	8	10
RPMA 42-B	230/208-3	187-253	18/19.5	35	25	10	10
RPMA 42-C+	460-3	414-506	10.0	15	15	14	14
RPMA 48	230/208-1	197-253	28.6/31.1	60	38	8	10
RPMA 48-B	230/208-3	187-253	21.5/23	40	27	10	10
RPMA 48-C+	460-3	414-506	12.0	20	15	14	14
RPMA 60	230/208-1	197-253	34.8/38.8	60	47	6	10
RPMA 60-B	230/208-3	187-253	26.3/28.3	50	34	8	10
RPMA 60-C+	460-3	414-506	13.4	25	16	12	12

* Maximum time delay fuse or HACR type circuit breaker, HACR not applicable to 460 volt.
 ** 60°C copper wire size, basic unit only.
 + 460V not UL listed.

OPTIONAL FIELD-INSTALLED ELECTRIC HEATER TABLE												
Heater Package Model No.	Heater Package Volts Phase	Htr. Kw & Capacity @ 240V (or 480V if applicable)		Heater Kw & Capacity @ 208 Volts		Heater Amps @ 240/208 (or 480V if applicable)	Heater Internal Fuses	CIRCUIT B				
		Kw	Btuh	Kw	Btuh			Number Field Ckts.	Minimum Circuit Ampacity	Max. Over- Current Protection	Field ^① Power Wiring	Ground Wire ^② Size
EH5RA-A10	240/208-1	10	34,100	7.5	25,600	41.6/36.2		1	53/46	60/50	6/6	10
EH5RA-A15	240/208-1	15	51,200	11.25	38,400	62.5/54.1	30/60	1	79/68	80/70	3/14	8
EH5RA-A20	240/208-1	20	68,200	15.0	51,200	83.2/72.1	60/60	1	104/91	110/100	2/3 ^③	6
EH5RA-A25	240/208-1	25	85,300	18.75	64,000	104.2/90.1	30/60/60	1	130/113	150/125	1/2 ^③	6
EH5RA-B09	240/208-3	9	30,700	6.75	23,000	21.7/18.7		1	28/24	30/25	10/10	10
EH5RA-B15	240/208-3	15	51,200	11.25	38,400	36.2/31.2		1	46/39	50/40	6/8	10
EH5RA-B24	240/208-3	24	81,900	18.0	61,400	57.9/50.0	40/40/40	1	73/63	80/70	3/4	8
EH5RA-C09	480-3	9	30,700	6.75	23,000	10.8		1	15	15	14	14
EH5RA-C15	480-3	15	51,200	11.25	38,400	18.0		1	23	25	10	10
EH5RA-C24	480-3	24	81,900	18.0	61,400	28.8		1	36	40	8	10

① Based on wire suitable for 60°C. Other wiring materials must be rated for marked "Minimum Circuit Ampacity" or greater.
 ② Based upon Table 250-95 of N.E.C. 1984.
 ③ For ampacities over 100 amperes use wire suitable for at least 75°C.
 See electrical data for basic air conditioning for Circuit A wiring specification requirements.

OPTIONAL FIELD-INSTALLED HEATER PACKAGES ARE ONLY TO BE USED
WITH THE AIR CONDITIONING MODELS AS INDICATED BELOW

Heater Model Number	Volts & Phase	RPMA 42	RPMA 42-B	RPMA 42-C	RPMA 48	RPMA 48-B	RPMA 48-C	RPMA 60	RPMA 60-B	RPMA 60-C
EH5RA-A10	240/208-1	S	A	A	S	A	A	S	A	A
EH5RA-A15	240/208-1	S	A	A	S	A	A	S	A	A
EH5RA-A20	240/208-1	S	A	A	S	A	A	S	A	A
EH5RA-A25	240/208-1	S	A	A	S	A	A	S	A	A
EH5RA-B09	240/208-3	A	S	A	A	S	A	A	S	A
EH5RA-B15	240/208-3	A	S	A	A	S	A	A	S	A
EH5RA-B24	240/208-3	A	S	A	A	S	A	A	S	A
EH5RA-C09	480-3	A	A	S	A	A	S	A	A	S
EH5RA-C15	480-3	A	A	S	A	A	S	A	A	S
EH5RA-C24	480-3	A	A	S	A	A	S	A	A	S

S - Standard application - heater volts and phase same as basic unit.
 A - Alternate application - heater volts and phase different from basic unit.

PRESSURE SERVICE PORTS

High and low pressure service ports are installed on all units so that the system operating pressures can be observed. Pressure curves can be found later in the manual covering all models. It is imperative to match the correct pressure curve to the unit by model number.

REFRIGERANT CHARGE

The correct system R-22 charge is shown on the unit rating plate. Optimum unit performance will occur with a refrigerant charge resulting in a suction line temperature (5" from compressor) as shown in the following table:

Model	Rated Airflow	95°F O.D. Temp.	82°F O.D. Temp.
RPMA42	1500	53 - 55	63 - 65
RPMA48	1700	56 - 58	64 - 66
RPMA60	1900	49 - 51	58 - 60

The above suction line temperatures are based upon 80°F dry bulb/67°F wet bulb (50% R.H.) temperature and rated airflow across the evaporator during cooling cycle.

AIR FILTER

Two 16"x30"x1" disposable fiberglass type filters are located inside the unit for air filtration of both return air from structure and for optional fresh air intake (see below).

Access to the filter is by removing the panel located next to the condensate drain connection.

FRESH AIR INTAKE

The fresh air intake cover is a manual damper operated device to allow intake of fresh air whenever indoor blower is operating. The damper position can be manually set and locked in position with a wing nut. It is held in place by two screws and has a hardware cloth screen to prevent entry of birds or rodents. An optional cover plate is available if fresh air intake is not used.

CRANKCASE HEATERS

All single and three phase models have an insertion well-type heater located in the lower section of the compressor housing. This is a self-regulating type heater that draws only enough power to maintain the compressor at a safe temperature.

Crankcase heat is essential to prevent liquid refrigerant from migrating to the compressor, causing oil pump out on compressor start-up and possible valve failure due to compressing a liquid.

The following decal is affixed to all outdoor units detailing the start-up procedure. This is very important. Please read carefully.

IMPORTANT

THESE PROCEDURES MUST BE FOLLOWED AT INITIAL START-UP AND AT ANY TIME POWER HAS BEEN REMOVED FOR 12 HOURS OR LONGER.

TO PREVENT COMPRESSOR DAMAGE WHICH MAY RESULT FROM THE PRESENCE OF LIQUID REFRIGERANT IN THE COMPRESSOR CRANKCASE

1. MAKE CERTAIN THE ROOM THERMOSTAT IS IN THE "OFF" POSITION (THE COMPRESSOR IS NOT TO OPERATE).
2. APPLY POWER BY CLOSING THE SYSTEM DISCONNECT SWITCH THE BLOWER OILS THE COMPRESSOR HEATER WHICH EVAPORATES THE LIQUID REFRIGERANT IN THE CRANKCASE.
3. ALLOW 4 HOURS OR 60 MINUTES PER POUND OF REFRIGERANT IN THE SYSTEM AS NOTED ON THE UNIT RATING PLATE WHICHEVER IS GREATER.
4. AFTER PROPERLY ELAPSED TIME THE THERMOSTAT MAY BE SET TO OPERATE THE COMPRESSOR.
5. EXCEPT AS REQUIRED FOR SAFETY WHILE SERVICING — DO NOT OPEN SYSTEM DISCONNECT SWITCH.

7981-061

SERVICE HINTS

1. Caution homeowner to maintain clean air filters at all times. Also not to needlessly close off supply and return air registers. This reduces air flow through the system, which shortens equipment service life as well as increasing operating costs.
2. The wall thermostats perform multiple functions. Be sure that all function switches are correctly set for the desired operating mode before trying to diagnose any reported service problems.
3. Check all power fuses or circuit breakers to be sure that they are the correct rating.
4. Periodic cleaning of the outdoor coil to permit full and unrestricted airflow circulation is essential.

If this unit is operated in cooling below a 65° outdoor ambient temperature, the installation of low ambient control (LAC-1) to unit is required.

PARTS LIST
SINGLE PACKAGE AIR CONDITIONERS

2/87

Part No.	Description	RPMA 42	RPMA 42-B	RPMA 42-C	RPMA 48	RPMA 48-B	RPMA 48-C	RPMA 60	RPMA 60-B	RPMA 60-C
* 5152-014	Blower Housing	x	x	x	x	x	x	x	x	x
5152-049	Blower Wheel 10-9	x	x	x	x	x	x	x	x	x
8552-030	Capacitor - Comp. 40/440V				x			(2)		
8552-043	Capacitor - Comp. 45/370V							(2)		
8552-004	Capacitor - Blower 7½/370V	x	x	x	x	x	x	(2)	(2)	(2)
8552-026	Capacitor - Blower/Fan 15/370V	x	x	x	x	x	x	(2)	(2)	(2)
8552-028	Capacitor - Comp. 35/440V	x								
5811-012	Capillary Tube	(4)	(4)	(4)						
5811-007	Capillary Tube				(3)	(3)	(3)			
5811-017	Capillary Tube							(4)	(4)	(4)
8000-058	Compressor CRJ3-0300-PFV	x								
8000-059	Compressor CRJ3-0300-TF5		x							
8000-060	Compressor CRJ3-0300-TFD			x						
8000-081	Compressor AV168ET				x					
8000-082	Compressor AV169RT					x				
8000-083	Compressor AV169TT						x			
8000-074	Compressor AG134ET							x		
8000-075	Compressor AC134RT								x	
8000-049	Compressor AG133UT									x
5051-027	Condenser Coil	x	x	x	x	x	x	x	x	x
8401-007	Contactora 25A1P	x								
8401-003	Contactora 30A1P				x					
8401-016	Contactora 35A1P							x		
8401-002	Contactora 25A3P		x	x		x	x			x
8401-011	Contactora 30A3P								x	
5060-030	Evaporator coil	x	x	x						
5060-029	Evaporator coil				x	x	x			
5060-038	Evaporator coil							x	x	x
5151-026	Fan Blade	x	x	x	x	x	x	x	x	x
8106-017	Motor - Blower	x	x	x	x	x	x			
8106-020	Motor - Blower							x	x	x
8106-021	Motor - Fan	x	x	x	x	x	x	x	x	x
8200-003	Motor Mount - Blower	x	x	x	x	x	x			
8200-027	Motor Mount - Fan	x	x	x	x	x	x	x	x	x
5451-011	Motor Mounting Parts	x	x	x	x	x	x	x	x	x
5153-022	Rain Shield	x	x	x	x	x	x	x	x	x
8201-008	Relay - Blower	x	x	(2)	x	x	(2)	x	x	(2)
5210-006	Strainer	x	x	x				x	x	x
5210-003	Strainer				x	x	x			
8607-013	Terminal Block	x			x			x		
8607-014	Terminal Block		x	x		x	x		x	x
8607-006	Terminal Board	x	x	x	x	x	x	x	x	x
7004-019	Filter 16x30x1	(2)	(2)	(2)	(2)	(2)	(2)	(2)	(2)	(2)
8607-015	Phenolic Insulator			x			x			x
8407-034	Transformer (40VA)	x	x	x	x	x	x	x	x	x
8407-004	Transformer (2KVA)	x			x			x		
7051-017	Condenser Grille	x	x	x	x	x	x	x	x	x
8200-028	Motor Mount							x	x	x
8607-017	Terminal Block			x			x			x

Minimum net billing \$15.00. Supersedes all previous lists.
Subject to change without notice. *Please order by model number. **Denotes change.

These curves are based upon 80°DB, 67°WB R.A. Temp. and rated CFM (airflow) across the evaporator coil and should be used for reference purposes only. Special information can be found under section titled "Refrigerant Charge" elsewhere in manual. If there is any doubt as to correct operating charge being in the system, the charge should be removed, system evacuated, and recharged according to serial plate instructions.

HIGH SIDE (DISCHARGE LINE) PRESSURE--PSIG

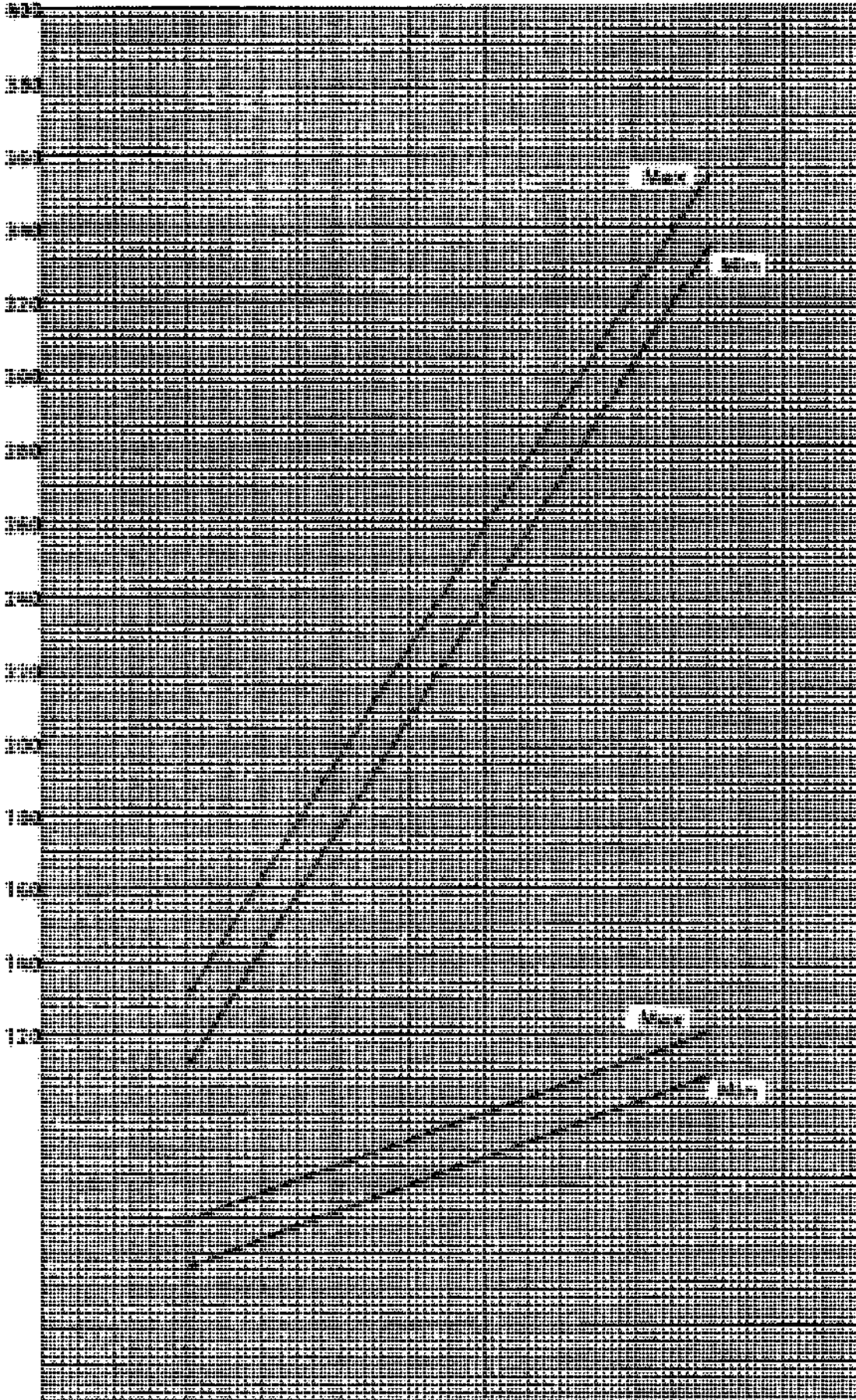

LOW SIDE PRESSURE--PSIG
(SUCTION LINE)

AIR TEMPERATURE ENTERING OUTDOOR COIL--DEGREE F.

The curves are based upon 80°DB, 67°WB R.A. Temp. ...
rate. CFM (airflow) across the evaporator coil and should be used for reference purposes only. Special information can be found under section titled "Refrigerant Charge" elsewhere in manual. If there is any doubt as to correct operating charge being in the system, the charge should be removed, system evacuated, and recharged according to serial plate instructions.

HIGH SIDE (DISCHARGE LINE) PRESSURE--PSIG

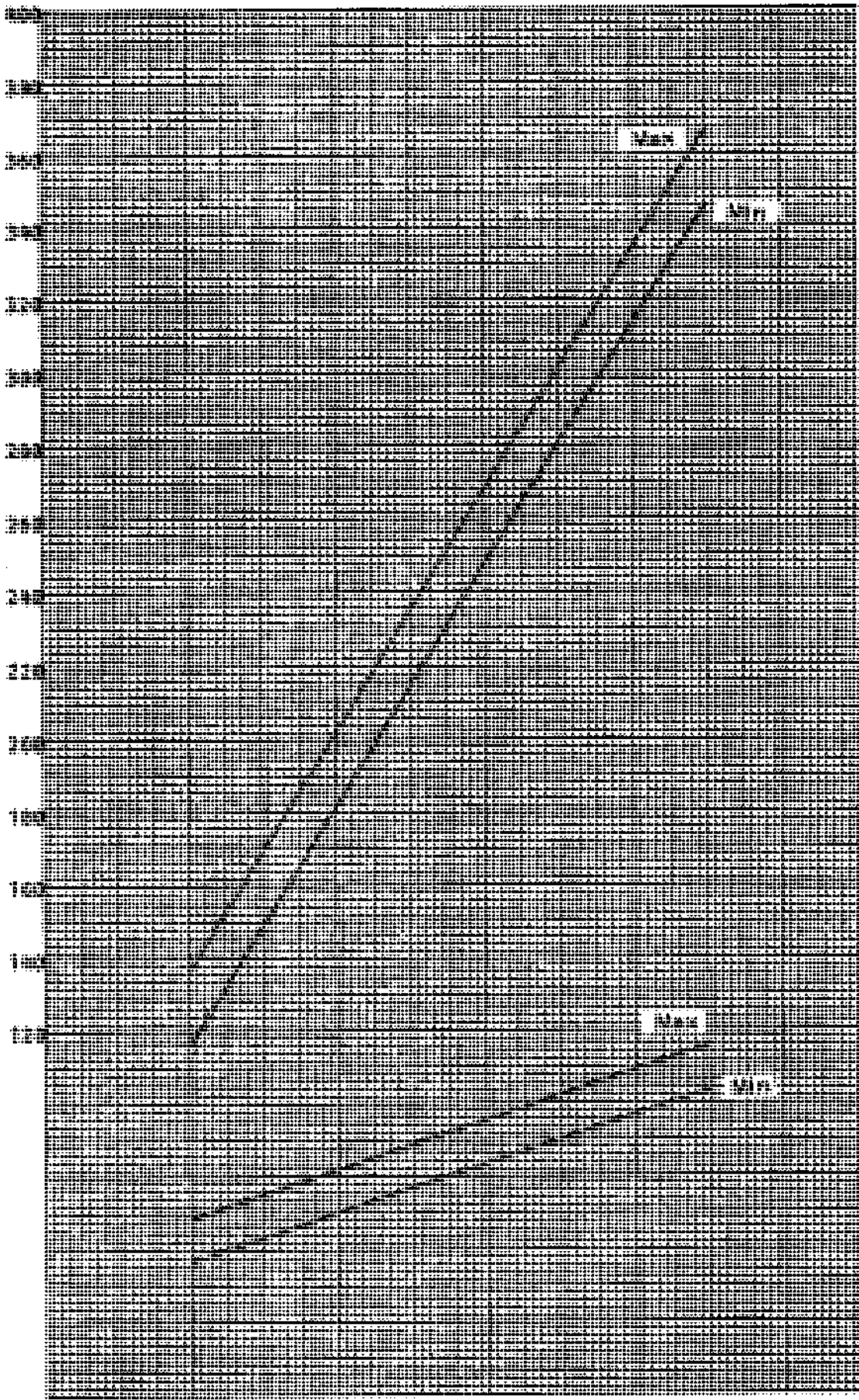

AIR TEMPERATURE ENTERING OUTDOOR COIL--DEGREE F.

LOW SIDE PRESSURE--PSIG
(SUCTION LINE)

These curves are based upon 80°DB, 67°WB R.A. Temp. and rated CFM (airflow) across the evaporator coil and should be used for reference purposes only. Special information can be found under section titled "Refrigerant Charge" elsewhere in manual. If there is any doubt as to correct operating charge being in the system, the charge should be removed, system evacuated, and recharged according to serial plate instructions.

HIGH SIDE (DISCHARGE LINE) PRESSURE--PSIG

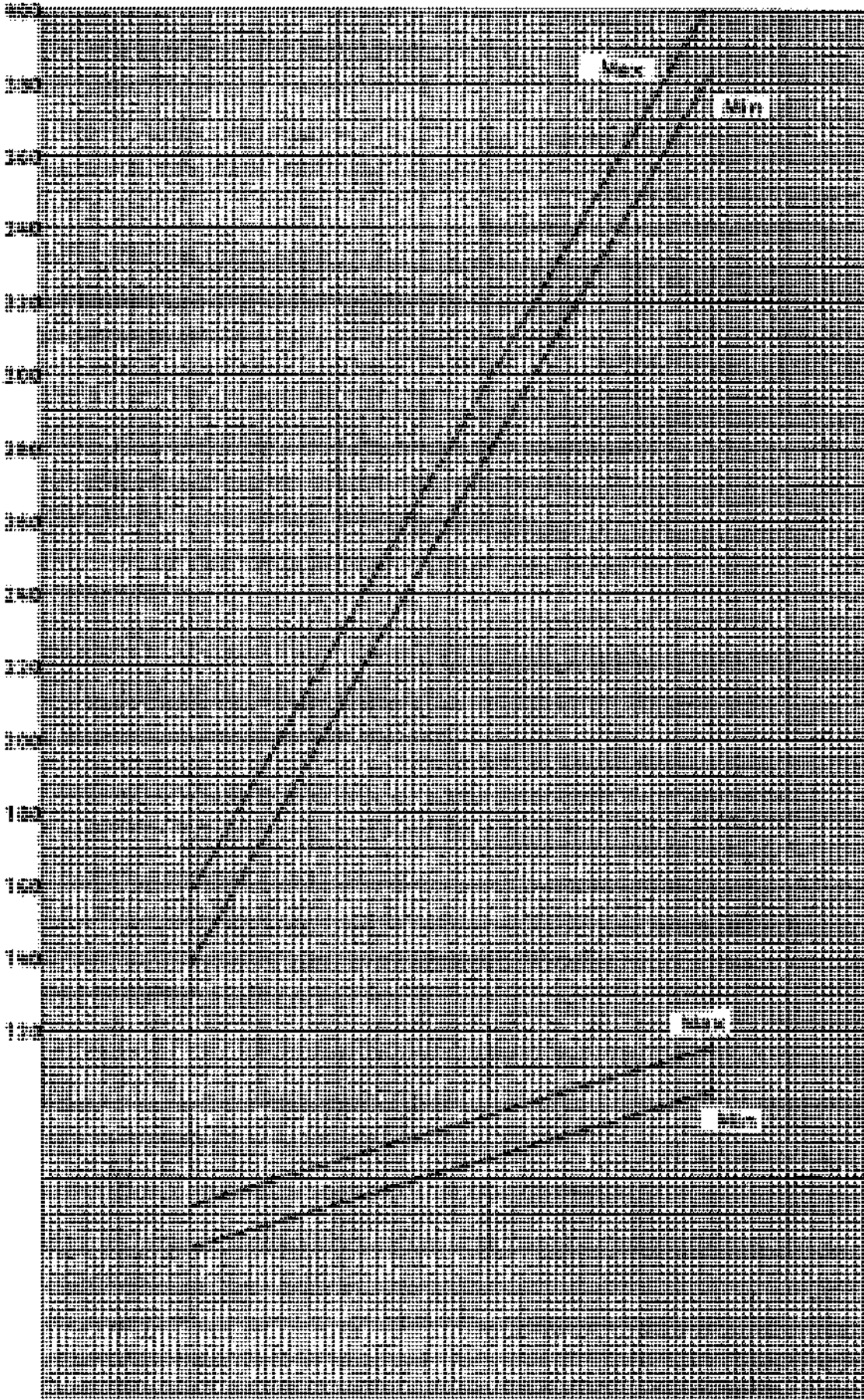

LOW SIDE PRESSURE--PSIG
(SUCTION LINE)

AIR TEMPERATURE ENTERING OUTDOOR COIL--DEGREE F.

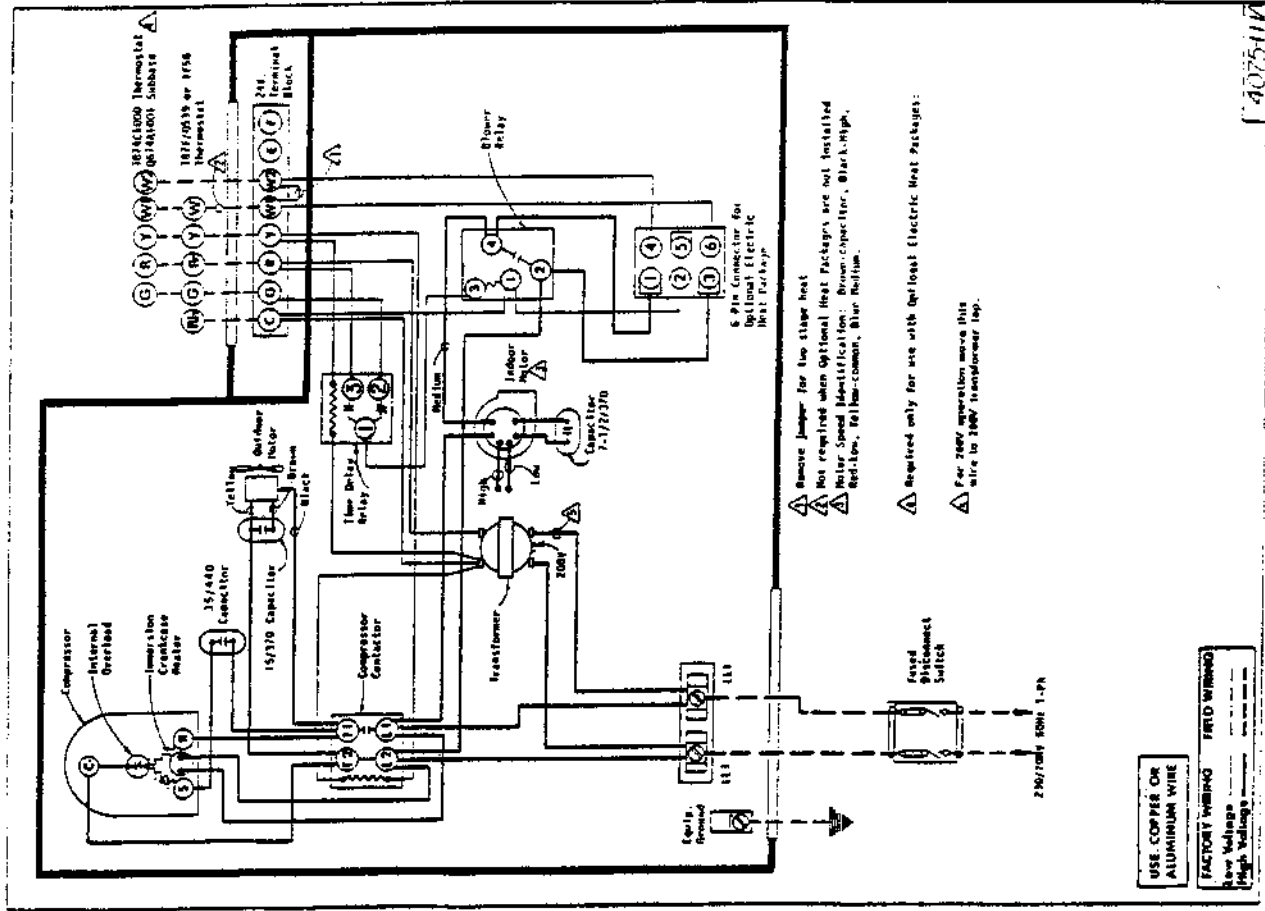
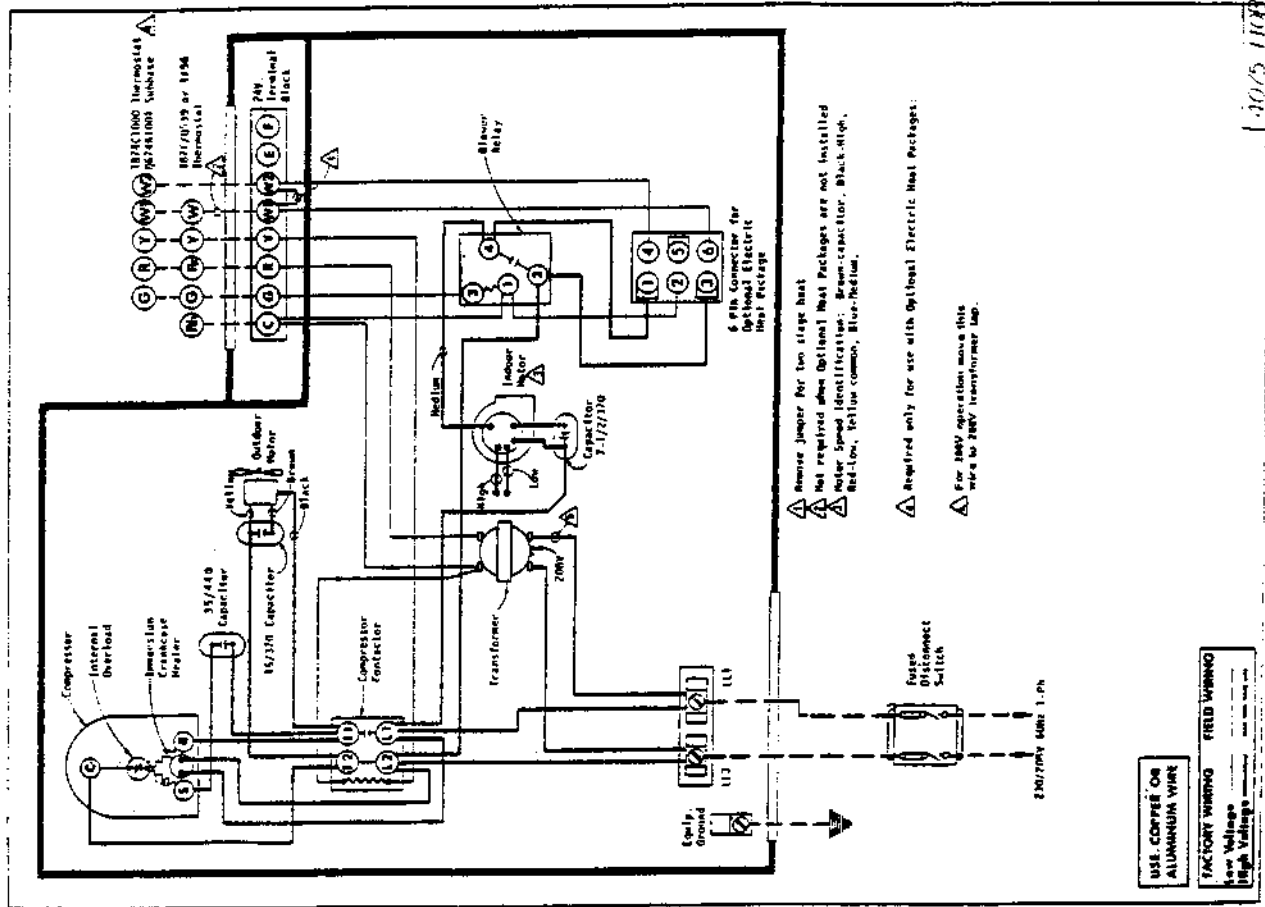

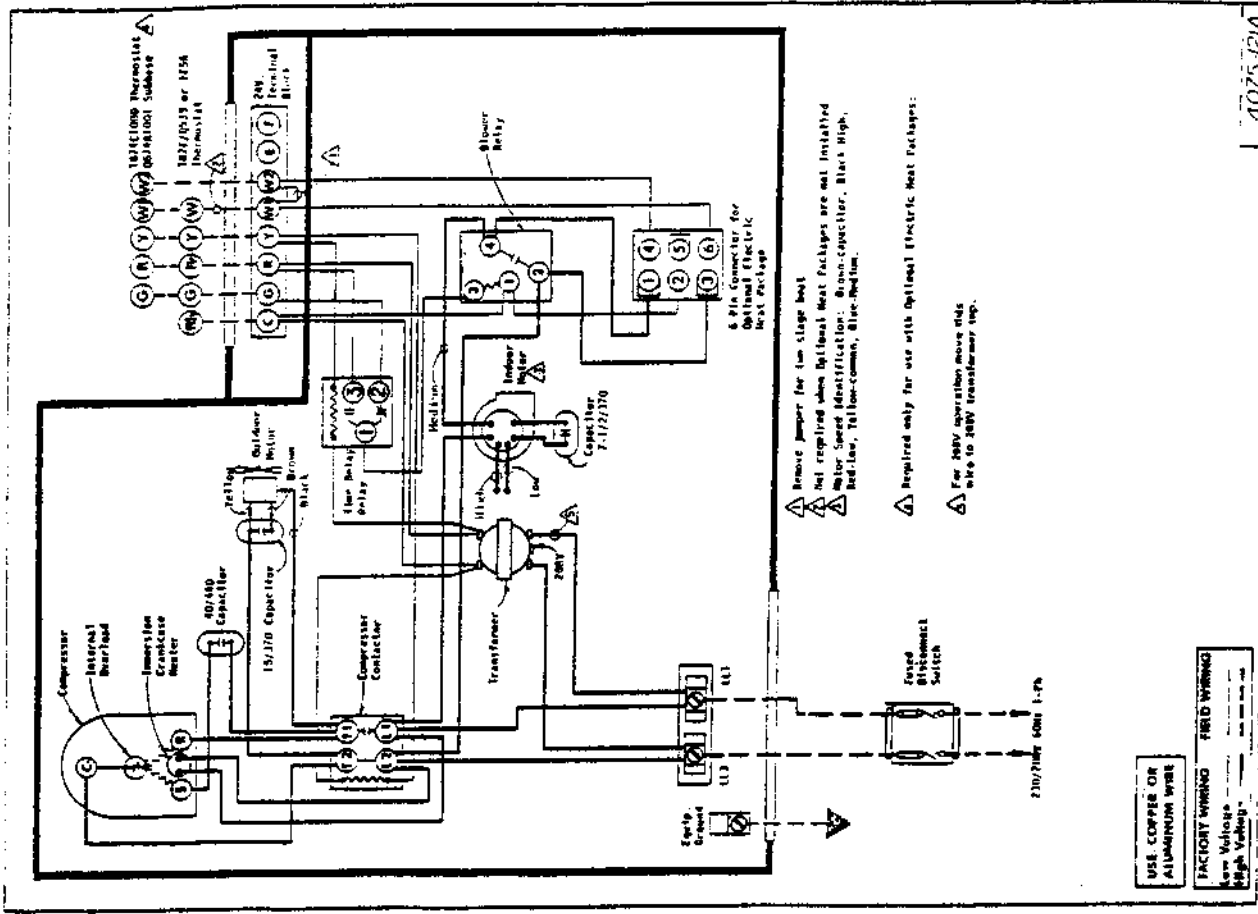
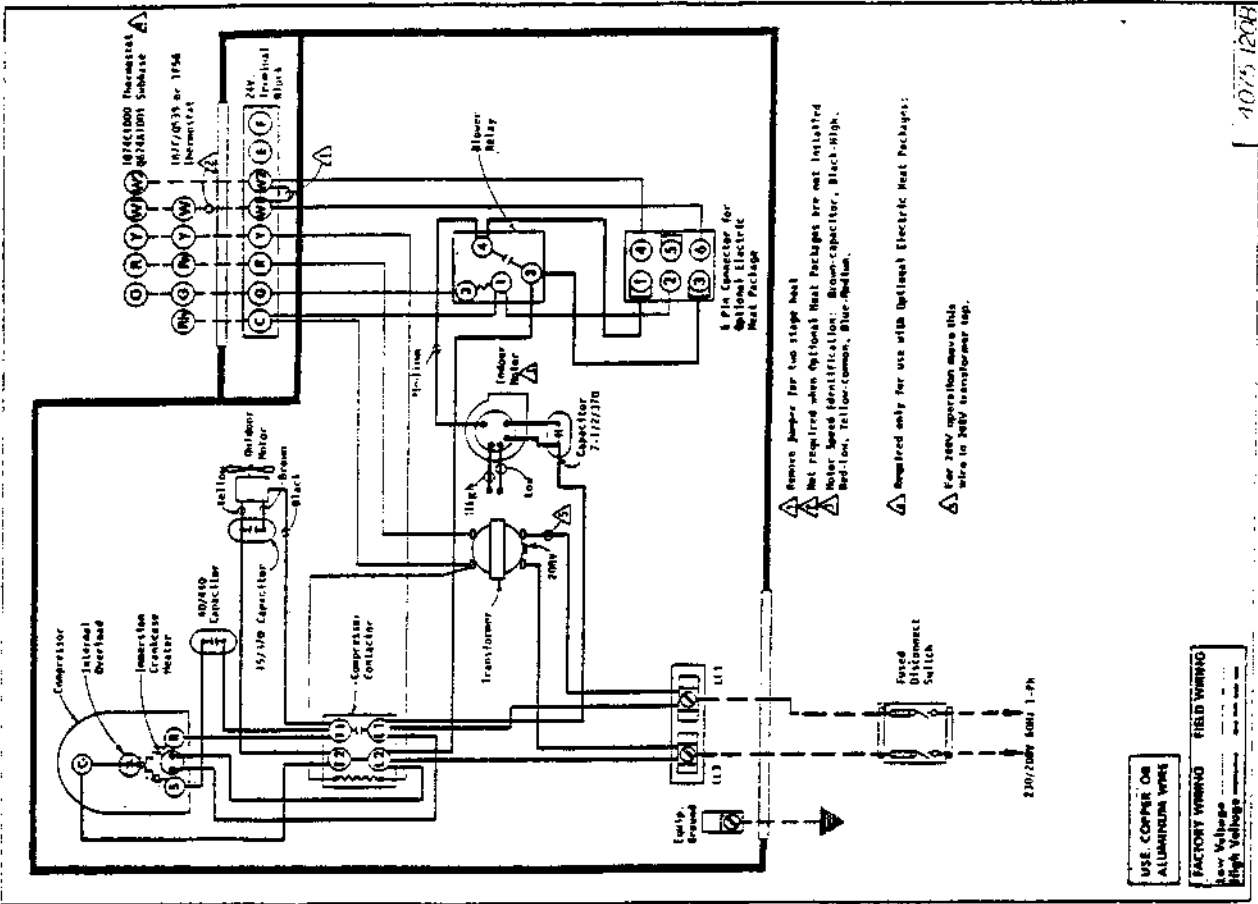

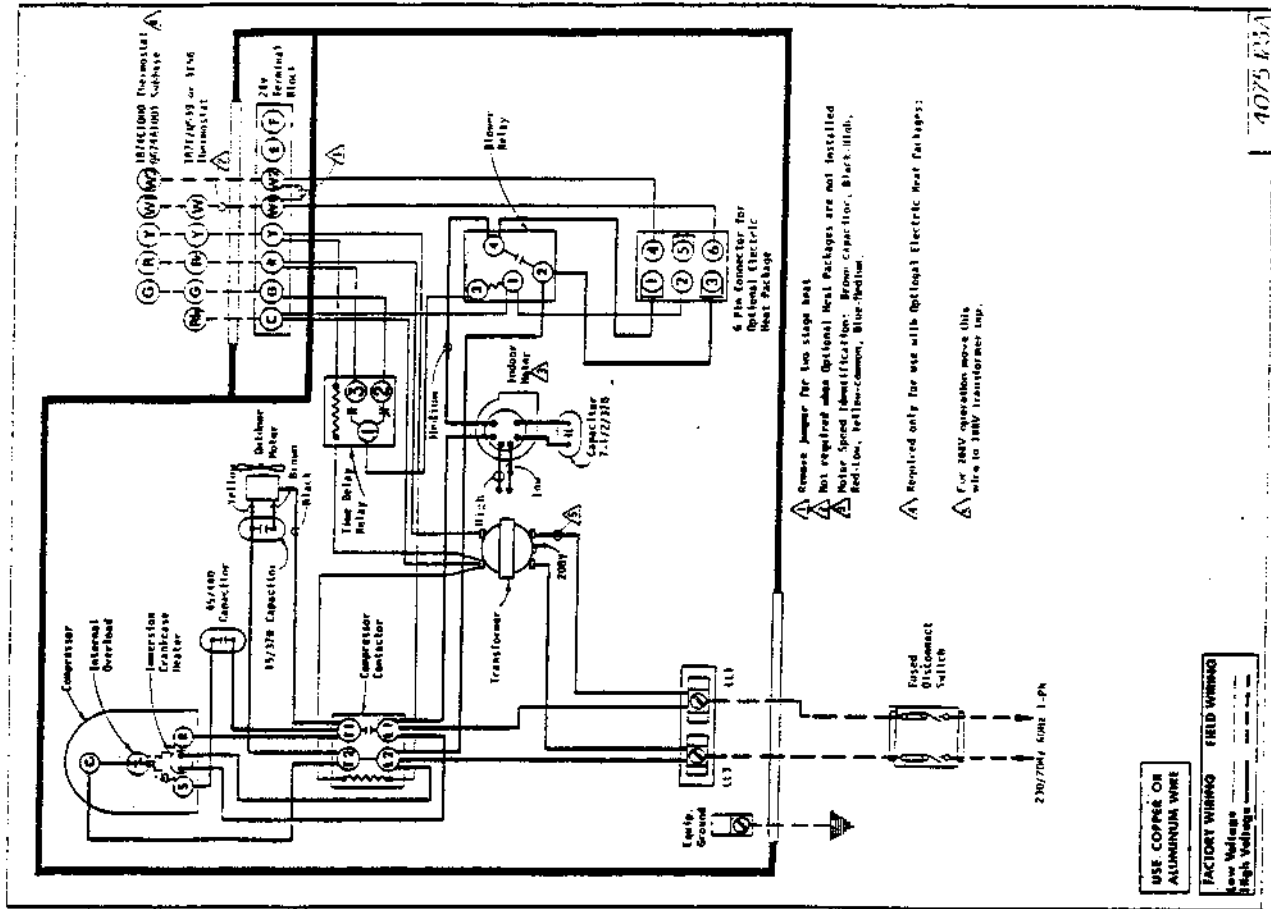
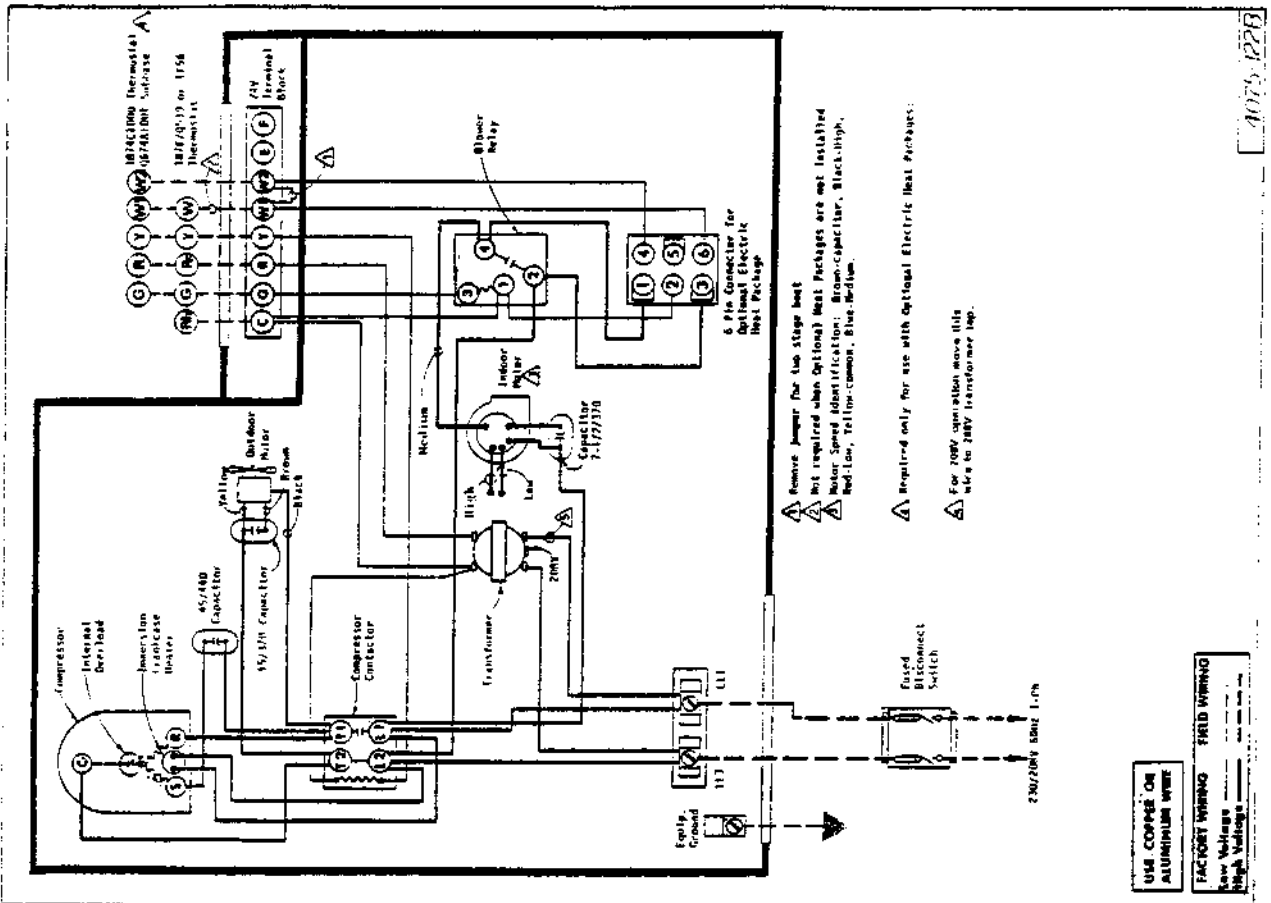

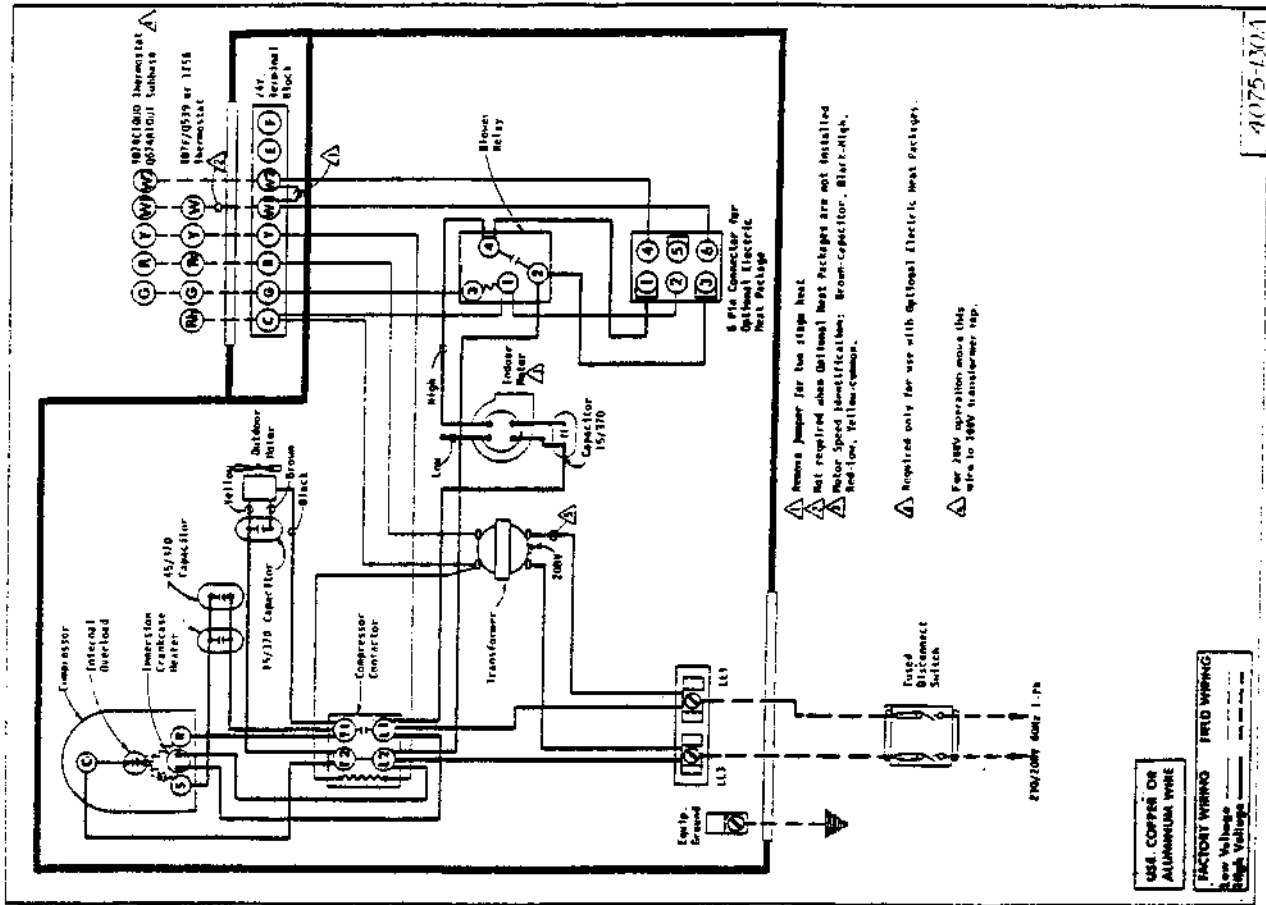

4075-130A

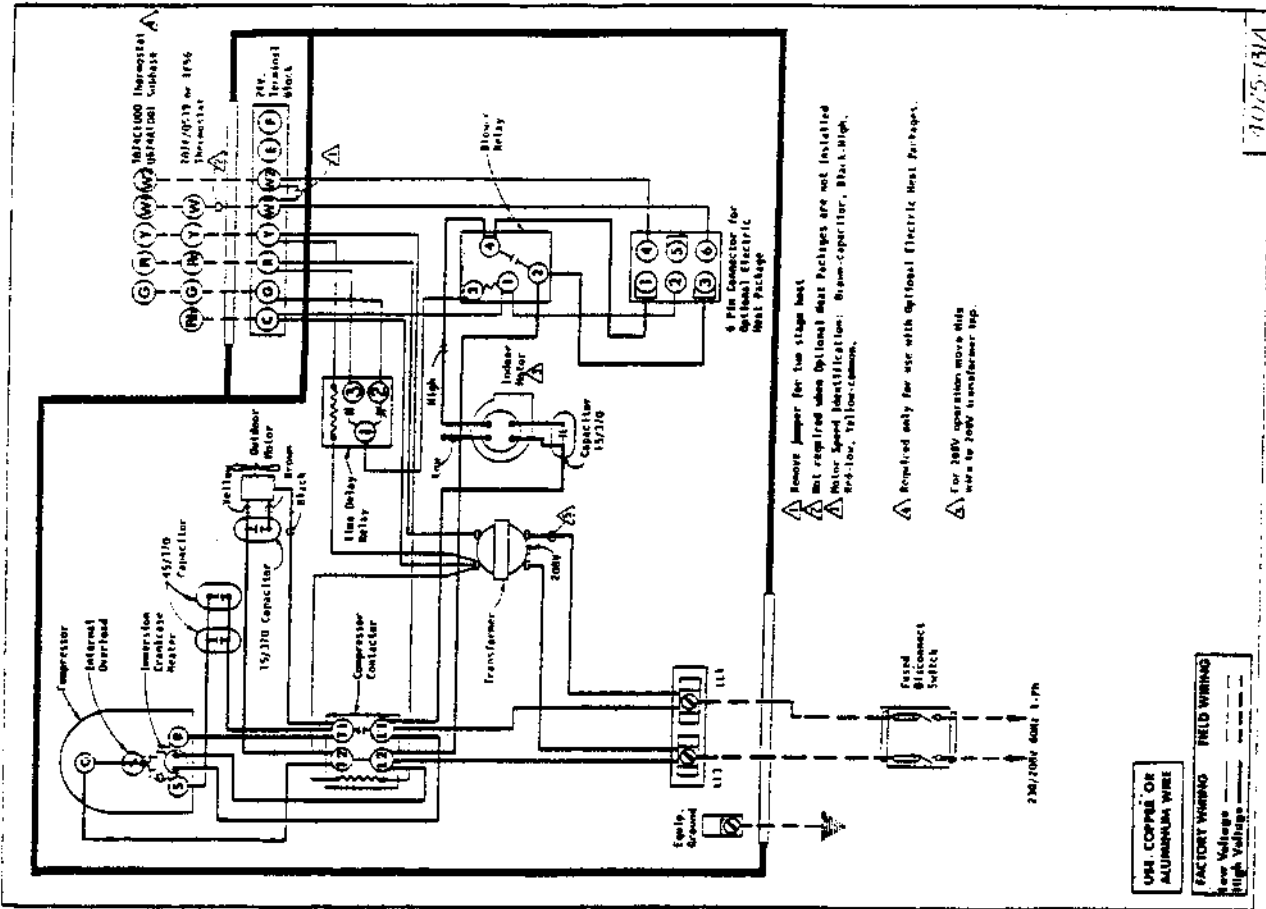

4075-130A

- ⚠ Remove jumper for two stage heat
- ⚠ Not required when Optional Heat Packages are not installed
- ⚠ Motor Speed Identification: Brown-capacitor, Black-high, Red-low, Yellow-common.
- ⚠ Required only for use with Optional Electric Heat Packages.
- ⚠ For 208V operation move wire to 208V transformer tap.

- ⚠ Remove jumper for two stage heat
- ⚠ Not required when Optional Heat Packages are not installed
- ⚠ Motor Speed Identification: Brown-capacitor, Black-high, Red-low, Yellow-common.
- ⚠ Required only for use with Optional Electric Heat Packages.
- ⚠ For 208V operation move this wire to 208V transformer tap.

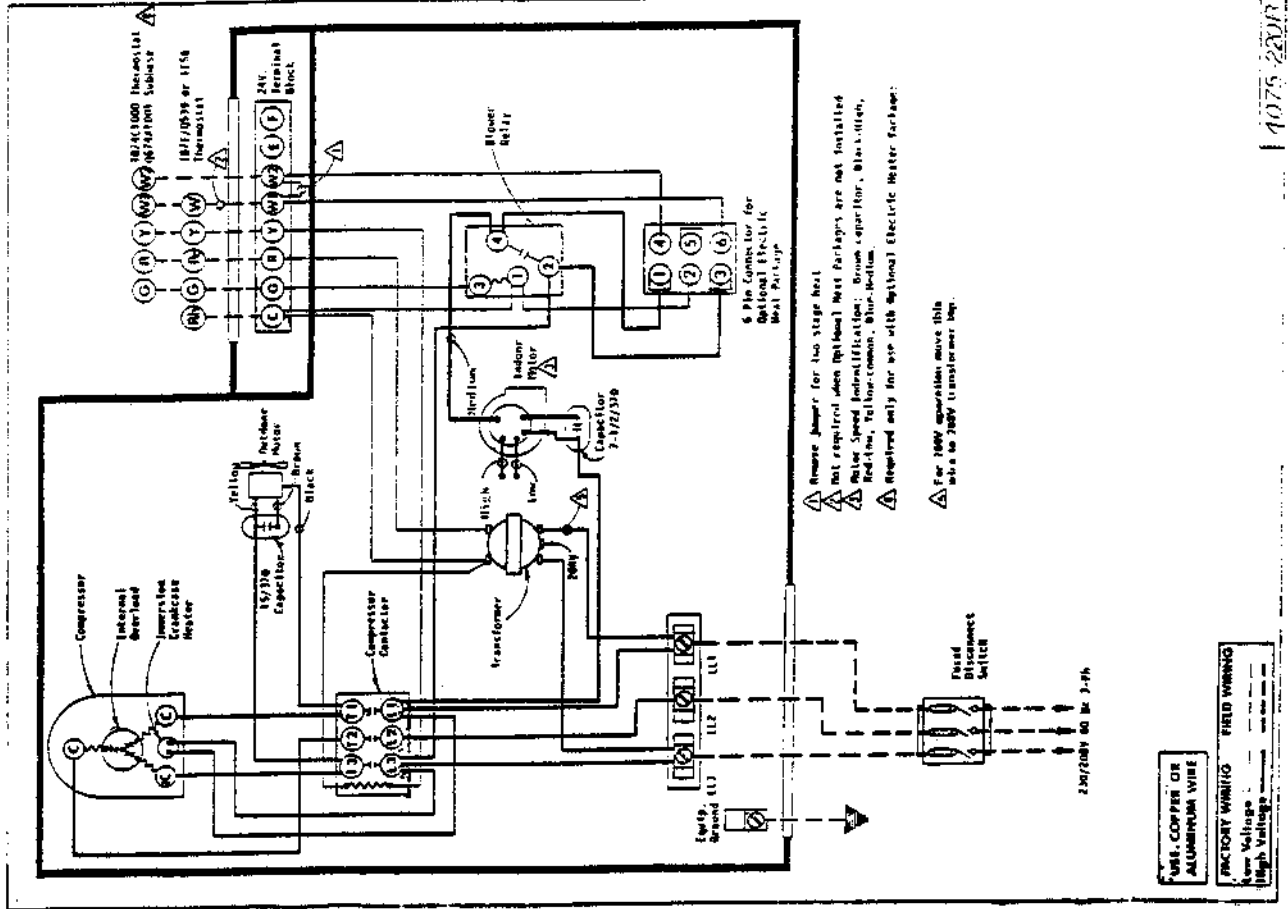
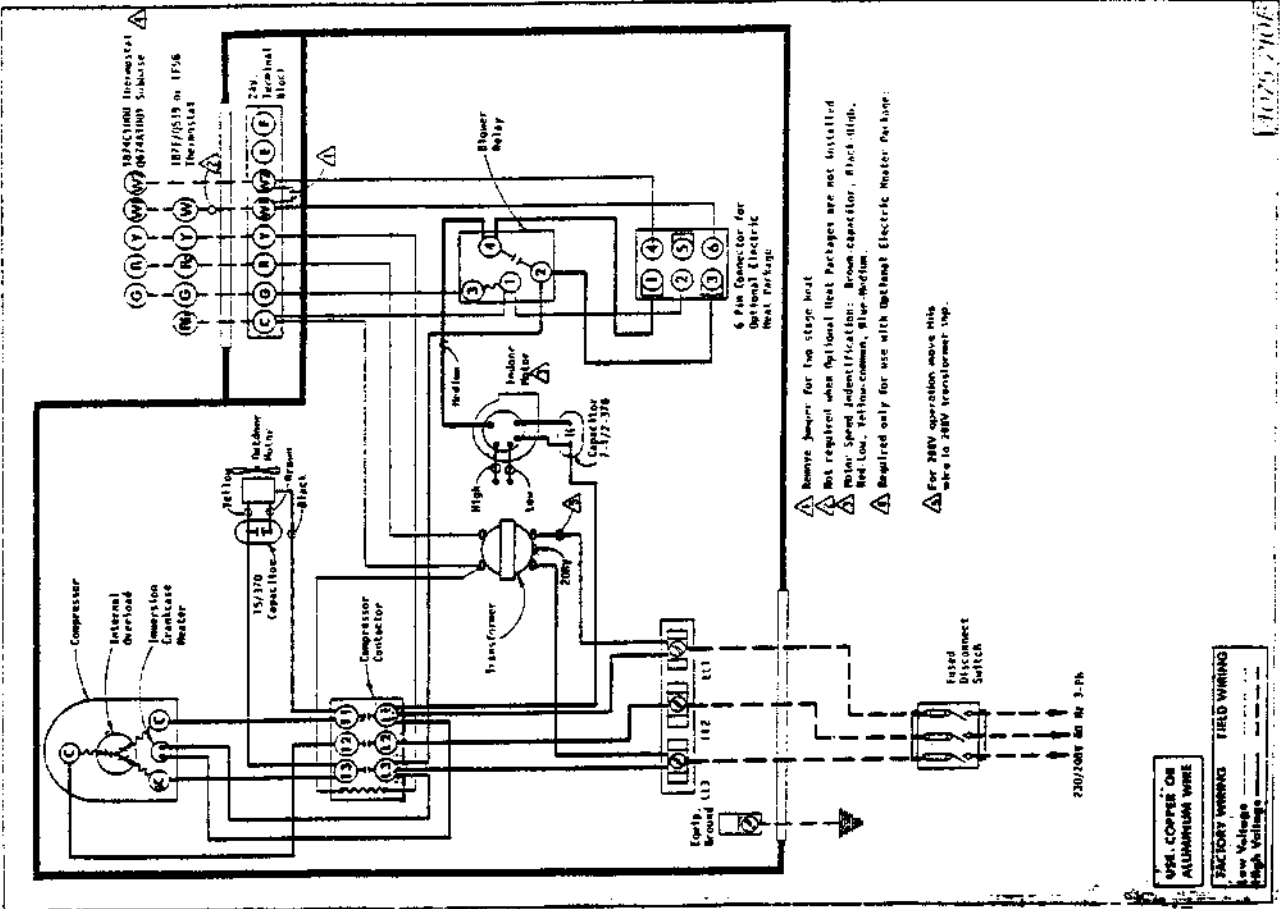

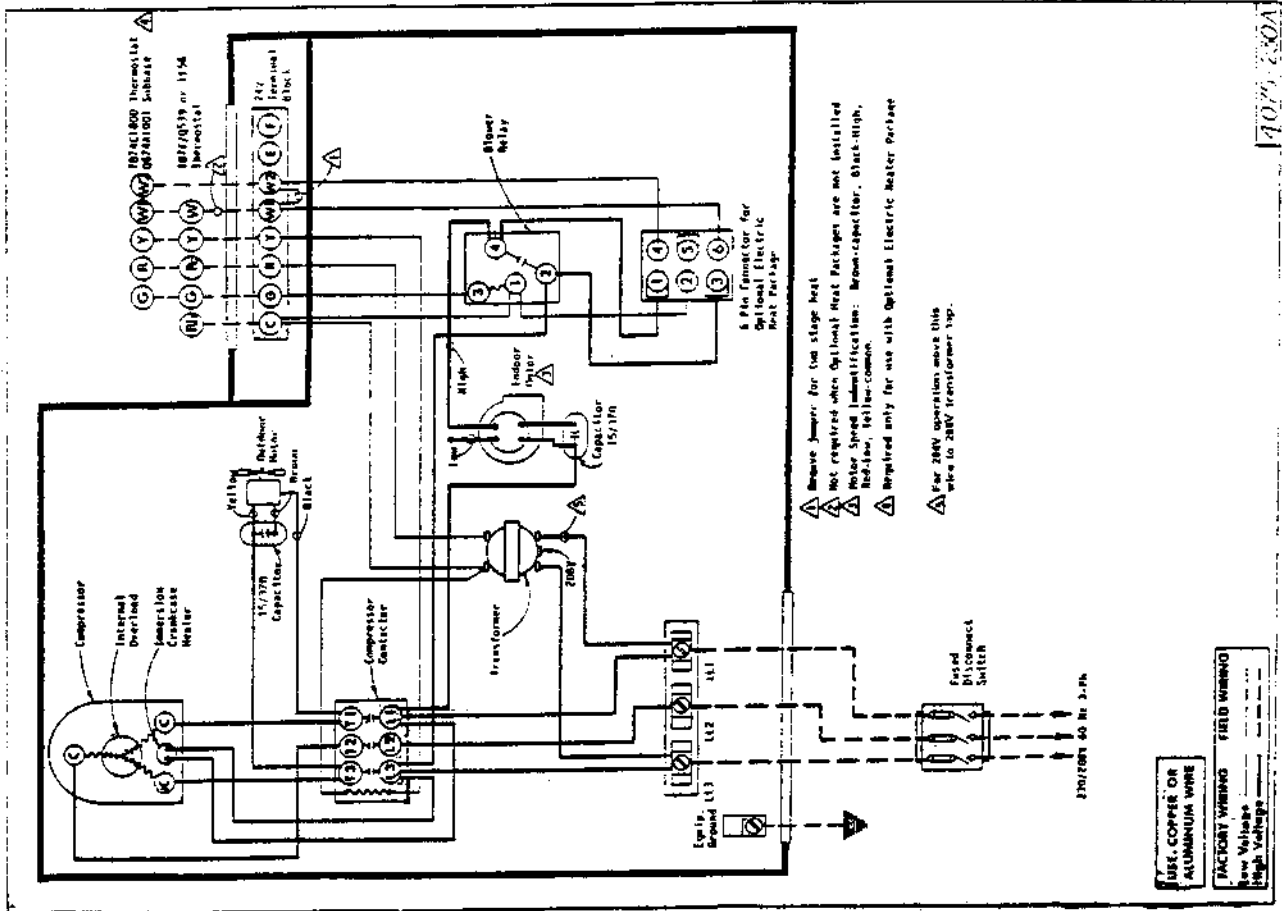

4075-30A

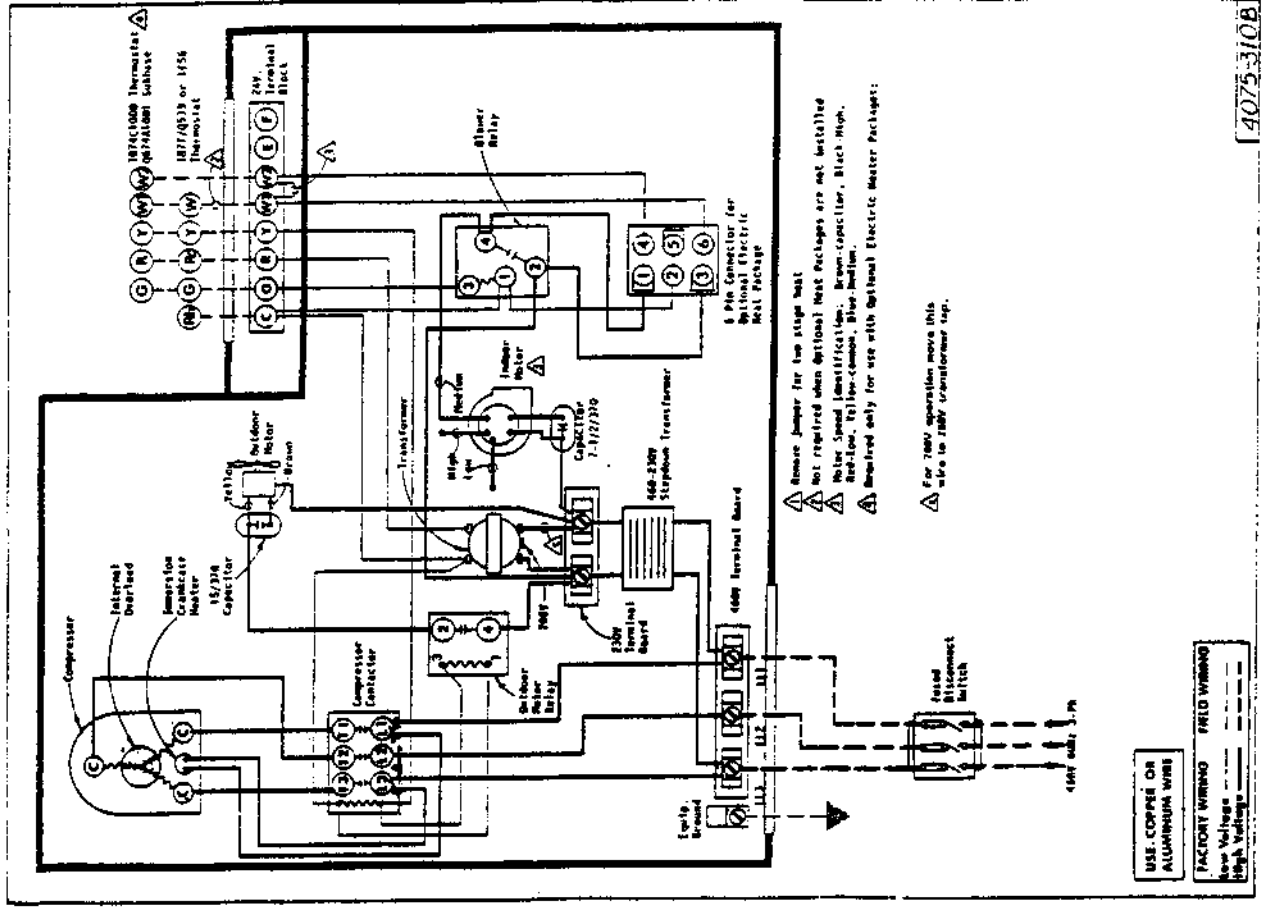

- ⚠ Remove Jumper for two stage heat
- ⚠ Not required when Optional Heat Packages are not installed
- ⚠ Motor Speed Identification: Brown-capacitor, Black-High, Red-Low, Yellow-common, Blue-Medium.
- ⚠ Required only for use with Optional Electric Heat Package:

⚠ For 280V operation move this wire to 280V transformer tap.

4075-310B

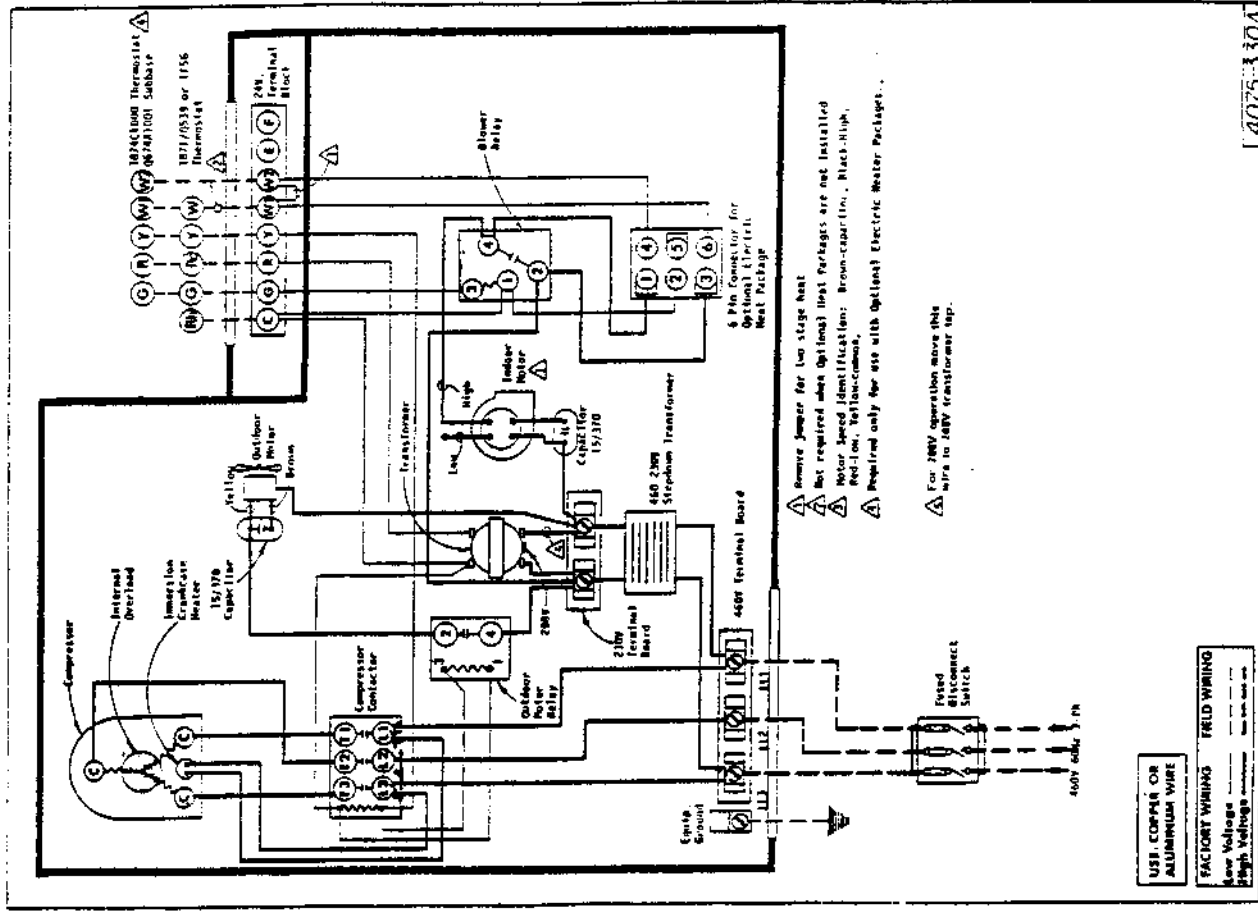
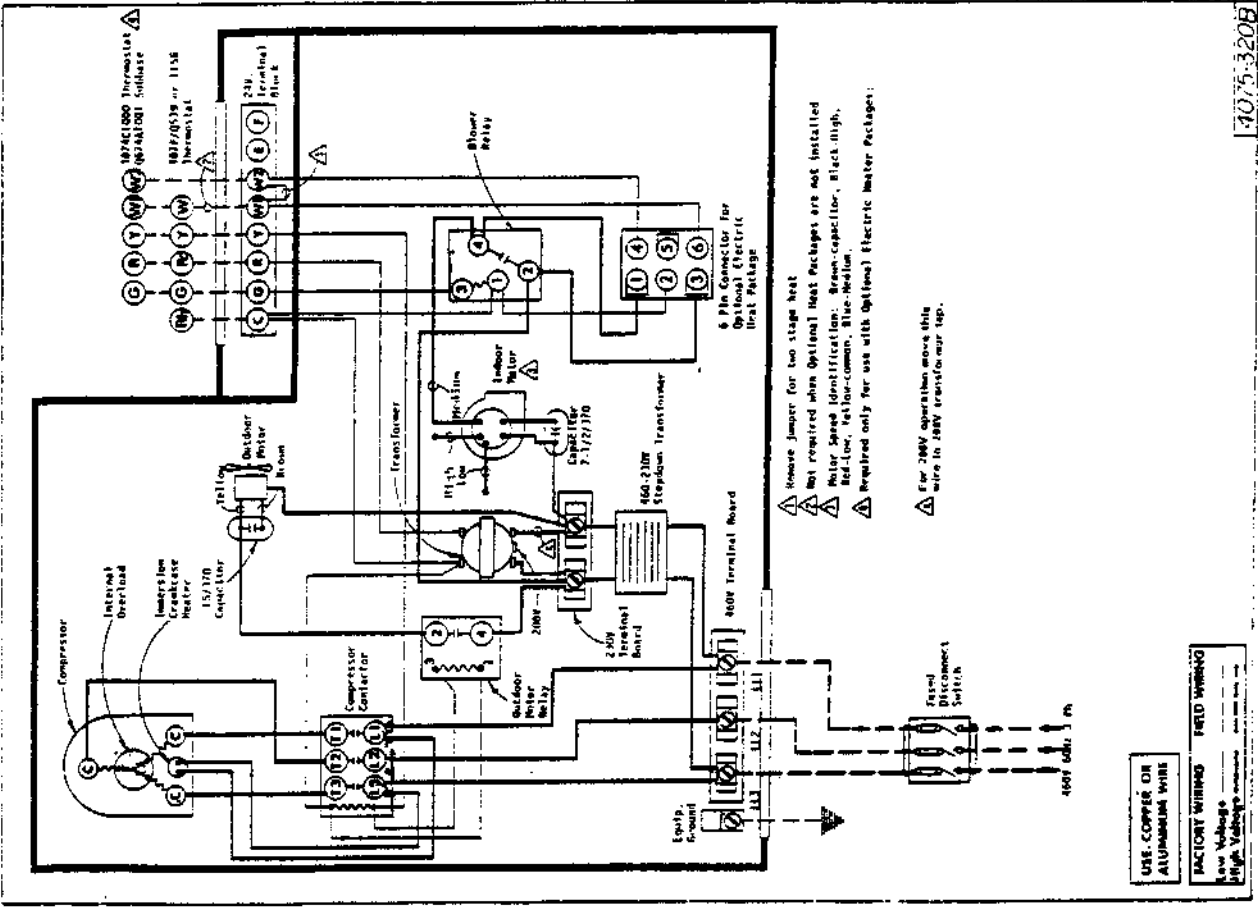

- ⚠ Remove jumper for two stage heat
- ⚠ Not required when Optional Heat Packages are not installed
- ⚠ Motor Speed Identification: Brown-Capacitor, Black-High, Red-Low, Yellow-Medium
- ⚠ Required only for use with Optional Electric Heater Packages.
- ⚠ For 208V operation move this wire to 208V transformer tap.

- ⚠ Remove jumper for two stage heat
- ⚠ Not required when Optional Heat Packages are not installed
- ⚠ Motor Speed Identification: Brown-Capacitor, Black-High, Red-Low, Yellow-Medium
- ⚠ Required only for use with Optional Electric Heater Packages.
- ⚠ For 208V operation move this wire to 208V transformer tap.