

SINGLE PACKAGE HEAT PUMP INSTALLATION INSTRUCTIONS

MODELS

2.5 TON
3 TON
3.5 TON
4 TON
5 TON

**FOR RESIDENTIAL AND COMMERCIAL
HEATING / COOLING APPLICATIONS**

ELECTRICAL DATA

Model	Rated Volts & PH	Operating Voltage Range	Max. Unit Amps	Req'd Maximum External Fuses or Ckt. Breaker*	Minimum Circuit Ampacity	Field Power Wiring**	Ground Wire Size**
				Ckt. A	Ckt. A	Ckt. A	Ckt. A
2.5 Ton	230/208-1	197-253	24.4	45	30	10	10
3 Ton	230/208-1	197-253	24.4	45	30	10	10
3 Ton	230/208-3	187-253	16.9	30	20	12	10
3 Ton	460-3	414-506	9.4	15	15	14	14
3.5 Ton	230/208-1	197-253	28.0	50	35	8	10
3.5 Ton	230/208-3	187-253	21.0	35	26	10	10
3.5 Ton	460-3	414-506	11	20	15	14	14
4 Ton	230/208-1	197-253	30	60	36	8	10
4 Ton	230/208-3	187-253	22	40	26	10	10
4 Ton	460-3	414-506	12.5	20	15	14	14
5 Ton	230/208-1	197-253	37.5	60	45	6	10
5 Ton	230/208-3	187-253	26.5	50	31	8	10
5 Ton	460-3	414-506	13.3	25	16	12	14

*Maximum time delay fuse or HACR type circuit breaker. HACR type not applicable to 460 volt.

**60°C copper wire size, basic unit only.

+460 volt not U.L. listed.

OPTIONAL FIELD-INSTALLED ELECTRIC HEATER TABLE

Heater Package Model No.	Unit Volts Phase	Htr. Kw & Capacity @ 240V (or 480V if applicable)		Heater Kw & Capacity @ 208 Volts		@ 240V or 480V as applicable Htr. Amps	Heater Internal Fuses	Circuit B				
		Kw	Btuh	Kw	Btuh			Number Field Ckts.	Minimum Circuit Ampacity	Max. Over-Current Protection ①	Field Power Wiring ②	Ground Wire Size ③
EH3PA-1-5A	230/208-1	5	17,100	3.75	12,800	20.8	30/60	1	26	30	10	10
EH3PA-1-10A	230/208-1	10	34,100	7.5	26,000	41.7		1	53	60	6	10
EH3PA-1-15A	230/208-1	15	51,200	11.25	38,400	62.5		1	79	80	3	8
EH3PA-3-9B	230/208-3	9	30,700	6.75	23,000	21.7		1	28	30	10	10
EH3PA-3-15B	230/208-3	15	51,200	11.25	38,400	36.2		1	46	50	6	10
EH3PA-3-9C	460-3	9	30,700	6.75	23,000	10.8		1	15	15	14	14
EH3PA-3-15C	460-3	15	51,200	11.25	38,400	18.0		1	23	25	10	10
EH5PA-1-5A	230/208-1	5	17,100	3.75	12,800	20.8	30/60 60/60	1	26	30	10	10
EH5PA-1-10A	230/208-1	10	34,100	7.5	26,000	41.7		1	53	60	6	10
EH5PA-1-15A	230/208-1	15	51,200	11.25	38,400	62.5		1	79	80	3	8
EH5PA-1-20A	230/208-1	20	68,200	15	51,200	83.2		1	104	110	2 ④	6
EH5PA-3-9B	230/208-3	9	30,700	6.75	23,000	21.7		1	28	30	10	10
EH5PA-3-15B	230/208-3	15	51,200	11.25	38,400	36.2		1	46	50	6	10
EH5PA-3-18B	230/208-3	18	61,400	13.5	46,100	43.4		1	55	60	6	10
EH5PA-3-9C	460-3	9	30,700	6.75	23,000	10.8	1	15	15	14	14	
EH5PA-3-15C	460-3	15	51,200	11.25	38,400	18.0	1	23	25	10	10	
EH5PA-3-18C	460-3	18	61,400	13.5	46,100	21.7	1	28	30	10	10	

① Time Delay fuses or "HACR Type" circuit breakers must be used for 60 and smaller sizes. Standard fuses or circuit breakers are suitable for sizes 70 and larger. 480V circuit breakers are not "HACR" type.

② Based on wire suitable for 60°C. Other wiring materials must be rated for marked "Minimum Circuit Ampacity" or greater.

③ Based upon Table 250-95 of N.E.C. 1984.

See electrical data for basic heat pump for Ckt. A wiring specification requirements.

④ For ampacities over 100 amperes use wire suitable for at least 75°C.

IMPORTANT; While this electrical data is presented as a guide, it is important to electrically connect, properly size fuses and conductor wires in accordance with the National Electrical Code and all existing local codes.

OPTIONAL FIELD-INSTALLED HEATER PACKAGES ARE ONLY TO BE USED WITH THE HEAT PUMP MODELS AS INDICATED BELOW

Heater Model No.	Volts and Ph	2.5 Ton	3 Ton	3 Ton	3 Ton	3.5 Ton	3.5 Ton	3.5 Ton	4 Ton	4 Ton	4 Ton	5 Ton	5 Ton	5 Ton
		EH3PA-1-5A	240/1	1	1	*	*							
EH3PA-1-10A	1	1		*	*									
EH3PA-1-15A	1	1		*	*									
EH3PA-3-9B	240/3	*	*	1	*									
EH3PA-3-15B		*	*	1	*									
EH3PA-3-9C		*	*	*	1									
EH3PA-3-15C	480/3	*	*	*	1									
EH5PA-1-5A	240/1					1	*	*	1	*	*	1	*	*
EH5PA-1-10A						1	*	*	1	*	*	1	*	*
EH5PA-1-15A						1	*	*	1	*	*	1	*	*
EH5PA-1-20A						1	*	*	1	*	*	1	*	*
EH5PA-3-9B	240/3					*	1	*	*	1	*	*	1	*
EH5PA-3-15B						*	1	*	*	1	*	*	1	*
EH5PA-3-18B						*	1	*	*	1	*	*	1	*
EH5PA-3-9C	480/3					*	*	1	*	*	1	*	*	1
EH5PA-3-15C						*	*	1	*	*	1	*	*	1
EH5PA-3-18C						*	*	1	*	*	1	*	*	1

1 - Standard application - Heater volts and phase same as basic unit.
 * - Alternate application - Heater volts and phase different from basic unit.

IMPORTANT

The equipment covered in this manual is to be installed by trained, experienced service and installation technicians. Any heat pump is more critical of proper operating charge and an adequate duct system than a straight air conditioning unit. All duct work, supply and return, must be properly sized for the design air flow requirement of the equipment. ACCA is an excellent guide to proper sizing. All duct work or portions thereof not in the conditioned space should be properly insulated in order to both conserve energy and prevent condensation or moisture damage.

SHIPPING DAMAGE

Upon receipt of equipment, the carton should be checked for external signs of shipping damage. If damage is found, the receiving party must contact the last carrier immediately, preferably in writing, requesting inspection by the carrier's agent.

GENERAL

The refrigerant system is completely assembled and charged. All internal wiring is complete.

The unit is designed for use with or without duct work. Flanges are provided for attaching the supply and return ducts.

These instructions explain the recommended method to install the air cooled self-contained unit and the electrical wiring connections to the unit.

These instructions and any instructions packaged with any separate equipment required to make up the entire air conditioning system should be carefully read before beginning the installation. Note particularly "Starting Procedure" and any tags and/or labels attached to the equipment.

While these instructions are intended as a general recommended guide, they do not supersede any national and/or local codes in any way. Authorities having jurisdiction should be consulted before the installation is made.

LOCATION

General - The unit must be located outside, or in a well ventilated area. It must not be in the space being heated or cooled. A sound absorbing material should be considered if the unit is to be installed in such a position or location that might cause transmission of sound or vibration to the living area or adjacent buildings.

Slab Mounting - In areas where winter temperatures DO NOT go below 32°F for periods over twelve hours, the unit may be slab mounted at grade level. When installing unit at grade level, install on a concrete slab at least four inches above finished grade level. Slab should have a slope tolerance away from the building structure of at least 1/4 inch per foot, while being level from side to side. This will prevent ice buildup under the unit during defrost cycles. Place slab in a location where run-off water from higher ground will not collect around unit. See Figure 1.

A minimum of 18 inches should be provided between the coil inlet and any building surfaces. Provide at least four feet between coil outlet and any building wall, fences or other vertical structures. Provide a minimum of three feet clearance on the service access side of the unit. See Figure 2.

Roof Mounting - When a unit is installed in areas where low ambient temperatures or strong winter winds exist, it should be placed so prevailing winter winds are not in direct line with the heat pump coil. If this is not possible, a wind barrier should be constructed. Place barrier 24 inches from the coil inlet side of the unit and in the direction of prevailing winds. Size barrier at least the same height and width as the unit. This may also be necessary on ground level installations. See Figure 3.

Winter Installation Below 32°F - In areas where winter conditions go below 32°F for extended periods, the unit must be elevated above the mounting surface to prevent snowfall or defrost ice accumulation from interfering with the operation of the unit. A minimum of twelve inch elevation is recommended, while greater elevation may be required for areas of high snow accumulation. Poured concrete, steel framework, brick, cement block, etc., can be utilized to construct a suitable raised mounting platform. See Figure 4.

TYPICAL INSTALLATION

- 1. Roof-Mounted** - The unit is mounted on a sturdy base on the roof of the building. Return air to the unit is brought through a single return grille (grilles with built-in filters are best, since they enable easy access for filter changing). Return air ducts are attached to the lower section of the front panel. Supply air is brought from the unit to attic duct work or to a furred down hall. Supply air duct is attached to the top of the front panel. CAUTION: All outdoor duct work must be thoroughly insulated and weatherproofed. All attic duct work must be thoroughly insulated. Two inch thick insulation with suitable vapor barrier is recommended for both outdoor and attic runs. In rooftop installations, as in all installations, the heat pump must be level from side to side. However, the unit should have a pitch along the length to assure complete external drainage of precipitation and of defrost condensate.
- 2. Crawl Space** - Duct work installed in crawl space must be well insulated and provided with a vapor barrier. In addition, the crawl space must be thoroughly ventilated and provided with a good vapor barrier as a ground cover. It is most desirable to install the unit outdoors, rather than inside the crawl space, so that it will be readily accessible for service. In addition, it is necessary to dispose of the condensate from the outdoor coil on the heating cycle, and this is virtually impossible with the unit installed inside the crawl space.
- 3. Slab Mounted at Ground Level** - This type installation is ideal for homes with a slab floor construction, where a roof-mounted unit is not desired. The supply and return duct work can be run through a furred closet space.
- 4. Thru-the-Wall** - This type installation requires a suitable framework to be fabricated capable of withstanding the unit weight. Normally the unit will be installed so as to minimize supply and return duct work.
- 5. Other Installations** - Many other installations are possible with the packaged heat pump. No matter what the installation, always consider the following facts:
 - a. Insure that the discharge air is not obstructed in any way so as to cause operation difficulties.
 - b. The indoor coil drain pan is equipped with a coupling that must be piped through a condensate drain trap to a suitable drain.
 - c. Always mount the unit in such a position that it may be easily reached for servicing and maintenance.
 - d. Insure that the unit is clear so that proper air flow over the outdoor coil will be maintained.

RATED CFM AND EXTERNAL STATIC PRESSURE (ESP) WET COIL (COOLING)			
Model	Rated CFM	Rated ESP	Recommended Air Flow Range
2.5 Ton	1125	.50	1000 - 1340 CFM
3 Ton	1275	.23	1150 - 1400 CFM
3.5 Ton	1500	.30	1520 - 1765 CFM
4 Ton 5 Ton	1700	.20	1520 - 1765 CFM

AIR FILTERS

Air filters for the return air side of the system are not provided as part of the basic piece of equipment because of the various types of application for these models, and must be field supplied and installed as part of the final installation.

Prior thought should be given to return air location and placement of the air filter(s). The air filter(s) must be of adequate size and readily accessible to the operator of the equipment. Filters must be adequate in size and properly maintained for proper operation. If this is not done, excessive energy use, poor performance, and multiple service problems will result. **IT IS IMPOSSIBLE TO OVERSIZE AIR FILTERS.** Generous sizing will result in cleaner air and coils, as well as lower operating costs and extend the time between required changes. The following table shows minimum filter areas and recommended filter sizes. Actual filter sizes can vary with the installation due to single or multiple returns utilizing a filter/grille arrangement or being placed immediately ahead of the indoor coil face in the return air duct.

Model	Minimum Filter Areas	Recommended Size
2.5 and 3 Ton	462 sq.in. (3.21 sq.ft)	12 x 50-5/8 x 1
3.5, 4 and 5 Ton	608 sq.in. (4.62 sq.ft)	(2) 16 x 20 x 1

NOTE: If Roof Hood Accessory is to be used, information on air filters may be found under that heading in this manual. Air filters are supplied as part of that package.

WIRING - MAIN POWER

Refer to the unit rating plate for wire sizing information and maximum fuse size. Each outdoor unit is marked with a "Minimum Circuit Amperity." This means that the field wiring used must be sized to carry that amount of current. If field installed heaters are added to the basic unit, a second, separate power supply circuit will be required. The heater rating plate located adjacent to the basic unit rating plate will show the appropriate circuit amperity, fuse size, etc. (Also see "Electrical Data" on page 1) Some models are suitable only for connection with copper wire, while others can be wired with either copper or aluminum wire. Each unit and/or wiring diagram will be marked "Use Copper Conductors Only" or "Use Copper or Aluminum Conductors." These instructions **MUST BE** adhered to. Refer to the National Electrical Code for complete current carrying capacity data on the various insulation grades of wiring material.

The electrical specifications on page 1 lists fuse and wire sizes (60°F copper) for all models, including the most commonly used heater sizes.

The unit rating plate lists a "Maximum Time Delay Fuse" or "HACR" Type Circuit Breaker that is to be used with the equipment. The correct size must be used for proper circuit protection and also to assure that there will be no nuisance tripping due to the momentary high starting current of the compressor.

WIRING - 24V CONTROL CIRCUIT

Ten (10) wires should be run from thermostat subbase to the 24V terminal board in the unit. A nine conductor, 18 gauge copper, color-coded thermostat cable is recommended. The connection points are shown on most of the wiring diagrams and are also shown below.

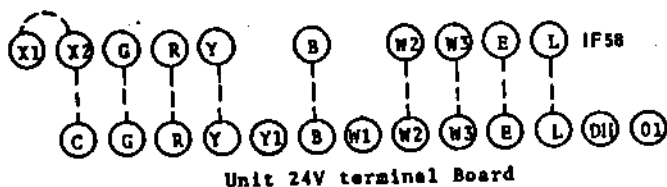

COMPRESSOR CUT-OFF THERMOSTAT & OUTDOOR THERMOSTATS

Heat pump compressor operation at outdoor temperatures below 0°F are neither desirable nor advantageous in terms of efficiency. Since most equipment at time of manufacture is not designated for any specific destination of the country, and most of the equipment is installed in areas not approaching the lower outdoor temperature range, the compressor cut-offs are not factory installed.

Outdoor thermostats are available to hold off various banks of electric heat until needed as determined by outdoor temperature. The set point of either type of thermostat is variable with geographic region and sizing of the heating equipment to the structure. Utilization of the Heating Application Data and the heat loss calculation of the building are useful in determining the correct set points.

COMPRESSOR CUT-OFF AND OUTDOOR THERMOSTAT WIRING

See specific wiring information for the different models, heater Kw's, and voltages on page 5.

THERMOSTAT INDICATOR LAMPS

The red lamp marked "EM.HT." comes on and stays on whenever the system switch is placed in the Em. Ht. position. The green lamp marked "check" will come on if there is any problem that prevents the compressor from running when it is supposed to be.

EMERGENCY HEAT POSITION

The operator of the equipment must manually place the system switch in this position. This is done when there is a known problem with the outdoor section, or when the green "check" lamp comes on indicating a problem.

COMPRESSOR MALFUNCTION RELAY (Single Phase Models Only)

Actuation of the green "check" lamp is accomplished by a voltage type relay which is factory installed. Any condition such as loss of charge, defective capacitor, defective contactor, etc., that will prevent compressor from operating will cause green lamp to activate. This is a signal to the operator of the equipment to place system in emergency heat position.

PRESSURE SERVICE PORTS

High and low pressure service ports are installed on all units so that the system operating pressures can be observed. Pressure curves can be found later in the manual covering all models on both cooling and heating cycles. It is imperative to match the correct pressure curve to the unit by model number.

SEQUENCE OF OPERATION

Cooling - Circuit R-Y makes at thermostat pulling in compressor contactor starting the compressor and outdoor motor. The G (indoor motor) circuit is automatically completed on any call for cooling operation, or can be energized by manual fan switch on subbase for constant air circulation.

Heating - A 24V solenoid coil on reversing valve controls heating cycle operation. Two thermostat options, one allowing "Auto" changeover from cycle to cycle and the other constantly energizing solenoid coil during heating season and thus eliminating pressure equalization noise except during defrost, are to be used. On "Auto" option, a circuit is completed from R-W1 and R-Y on each heating "on" cycle, energizing reversing valve solenoid and pulling in compressor contactor starting compressor and outdoor motor. R-G also make starting indoor blower motor. Heat pump heating cycle now in operation. The second option has no "Auto" changeover position, but instead energizes the reversing valve solenoid constantly whenever the system switch on subbase is placed in "Heat" position, the "B" terminal being constantly energized from R. A thermostat demand for heat completes R-Y circuit, pulling in compressor contactor starting compressor and outdoor motor. R-G also make starting indoor blower motor.

DEFROST CYCLE

The defrost timer cycle is controlled by time and temperature. The 24 volt timer motor runs all the time the compressor is in operation. When the outdoor temperature is in the lower 40°F temperature range or colder, the outdoor coil temperature is 32°F or below. This temperature is sensed by the defrost thermostat mounted near the bottom of the outdoor coil on a return bend. The defrost thermostat closes at approximately 32°F. Every 60 (or 30) minutes that the compressor is running, contacts 3-5 close for 7 minutes, with contacts 3-4 closed for the first 40 seconds of that 7 minutes. If the defrost thermostat is closed, the defrost relay energizes and places the system in defrost mode. An interlocking circuit is created with timer contacts 3-5 and defrost relay contacts 7-9 in series.

During the defrost mode, the refrigerant cycle switches back to the cooling cycle, the outdoor motor stops, electric heaters are energized, and hot gas passing through the outdoor coil melts any accumulated frost. When the temperature rises to approximately 57°F, the defrost thermostat opens, de-energizing the defrost relay and returning the system to heating operation.

If some abnormal or temporary condition such as a high wind causes the heat pump to have a prolonged defrost cycle, contacts 3-5 of the defrost timer will open after 7 minutes and restore the system to heating operations automatically.

There are two time settings on the defrost timer--30 minutes and 60 minutes. Most models are shipped wired on the 60 minute setting for greatest operating economy. If special circumstances require a change to the shorter time, remove wire connected to terminal 5/60 and reconnect to terminal 5/30.

There is a manual advance knob located on the timer. This can be used to advance timer to contact closure point if it is desired to check out defrost cycle operation, without waiting for time to elapse.

IMPORTANT INSTALLER NOTES

For improved start-up performance wash the indoor coil with a dishwasher detergent.

DEFROST TIMER WIRING

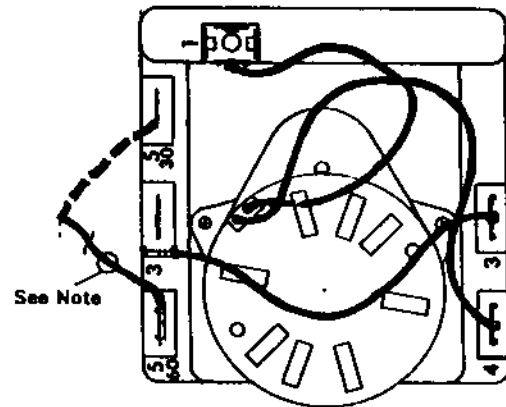

NOTE: All models are connected to 5/60 terminal (60 minute). Any model can be changed from 60 minutes to 30 minutes by unplugging from 5/60 terminal and reconnecting to 5/30 terminal.

SERVICE HINTS

1. Caution homeowner to maintain clean air filters at all times. Also, not to needlessly close off supply and return air registers. This reduces air flow through the system, which shortens equipment service life as well as increasing operating costs.
2. Switching to heating cycle at 75°F or higher outside temperature may cause a nuisance trip of the manual reset high pressure switch.
3. The heat pump wall thermostats perform multiple functions. Be sure that all function switches are correctly set for the desired operating mode before trying to diagnose any reported service problems.
4. Check all power fuses or circuit breakers to be sure that they are the correct rating.
5. Periodic cleaning of the outdoor coil to permit full and unrestricted airflow circulation is essential.

REFRIGERANT CHARGE

The correct system R-22 charge is shown on the unit rating plate. Optimum unit performance will occur with a refrigerant charge resulting in a suction line temperature (6" from compressor) as shown in the following table:

Model	Rated Airflow	95°F O.D. Temp.	82°F O.D. Temp.
2.5 Ton	1075	55 - 57	63 - 65
3 Ton	1275	55 - 57	60 - 62
3.5 Ton	1500	60 - 62	67 - 69
4 Ton	1700	51 - 53	60 - 62
5 Ton	1700	59 - 61	64 - 66

The above suction line temperatures are based upon 80°F dry bulb/67°F wet bulb (80% R.H.) temperature and rated airflow across the evaporator during cooling cycle.

CRANKCASE HEATERS

All units are provided with some form of compressor crankcase heat. Some single phase units utilize the compressor motor start winding in series with a portion of the run capacitor to generate heat within the compressor shell to prevent liquid refrigerant migration.

Some single and three phase models have an insertion well-type heater located in the lower section of the compressor housing. This is a self-regulating type heater that draws only enough power to maintain the compressor at a safe temperature.

Some form of crankcase heat is essential to prevent liquid refrigerant from migrating to the compressor, causing oil pump out on compressor start-up and possible valve failure due to compressing a liquid.

Refer to unit wiring diagram to find exact type of crankcase heater used.

The following decal is affixed to all outdoor units detailing start-up procedure. This is very important. Please read carefully.

IMPORTANT

THESE PROCEDURES MUST BE FOLLOWED AT INITIAL START-UP AND AT ANY TIME POWER HAS BEEN REMOVED FOR 12 HOURS OR LONGER.

TO PREVENT COMPRESSOR DAMAGE WHICH MAY RESULT FROM THE PRESENCE OF LIQUID REFRIGERANT IN THE COMPRESSOR CRANKCASE

1. MAKE CERTAIN THE ROOM THERMOSTAT IS IN THE "OFF" POSITION (THE COMPRESSOR IS NOT TO OPERATE).
2. APPLY POWER BY CLOSING THE SYSTEM DISCONNECT SWITCH THIS ENERGIZES THE COMPRESSOR HEATER WHICH EVAPORATES THE LIQUID REFRIGERANT IN THE CRANKCASE.
3. ALLOW 4 HOURS OR 90 MINUTES PER POUND OF REFRIGERANT IN THE SYSTEM AS NOTED ON THE UNIT RATING PLATE, WHICHEVER IS GREATER.
4. AFTER PROPERLY ELAPSED TIME THE THERMOSTAT MAY BE SET TO OPERATE THE COMPRESSOR.
5. EXCEPT AS REQUIRED FOR SAFETY WHILE SERVICING — DO NOT OPEN SYSTEM DISCONNECT SWITCH.

7061-081

COMPRESSOR CUT-OFF WIRING

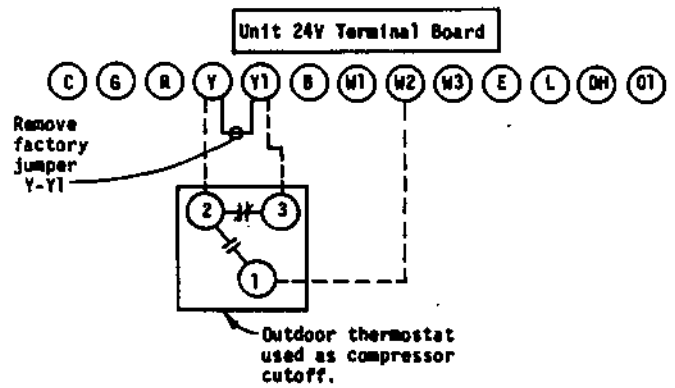

MODEL	KW	VOLTS	PHASE
2.5 Ton	0, 5, 10	230	1
3 "	0, 5, 10	230	1
3 "	0, 6, 9, 12, 15	230, 460	3
3.5 "	0, 5, 10	230	1
3.5 "	0, 9, 12, 15	230, 460	3
4 "	0, 5, 10	230	1
4 "	0, 9, 12, 15	230, 460	3
5 "	0, 5, 10	230	1
5 "	0, 9, 12, 15	230, 460	3

COMPRESSOR CUT-OFF & OUTDOOR THERMOSTAT WIRING

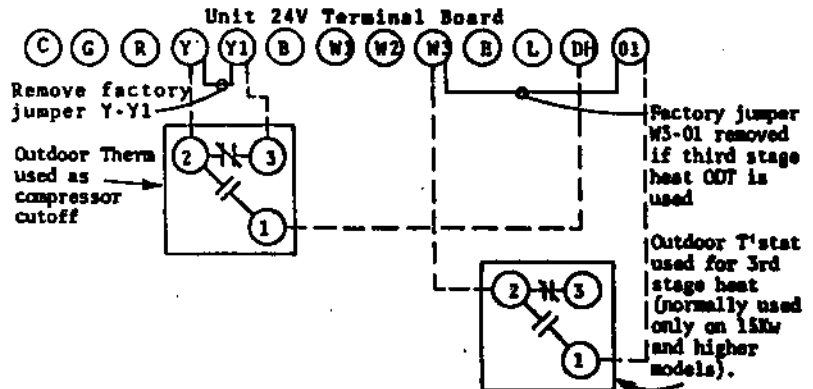

OPTIONAL ELECTRIC HEATERS

These packaged heat pumps are manufactured without supplementary electric heaters. Supplementary heaters EH3PA series (to fit 2.5 and 3 ton) and EH5PA series (to fit 3.5, 4 and 5 ton) are available for simple, fast, field installation.

A separate field power circuit is required for the supplementary heaters.

Refer to the electrical data shown on page 3 for proper application information on all available heater combinations and what units they can be used with. It also shows the applicable circuit ampacities, fuse size and wire size for each heater combination.

Refer to the installation instructions packed with the heater for details on how to insert it into the basic unit.

MODEL	KW	VOLTS	PHASE
2.5 Ton	15	230	1
3 "	15	230	1
3.5 "	15, 20	230	1
4 "	15, 20	230	1
4 "	18	230, 460	3
5 "	15, 20	230	1
5 "	18	230, 460	3

Figure 1

SLAB MOUNTED AT GROUND LEVEL
(Above 3°Fy Outside Temperature)

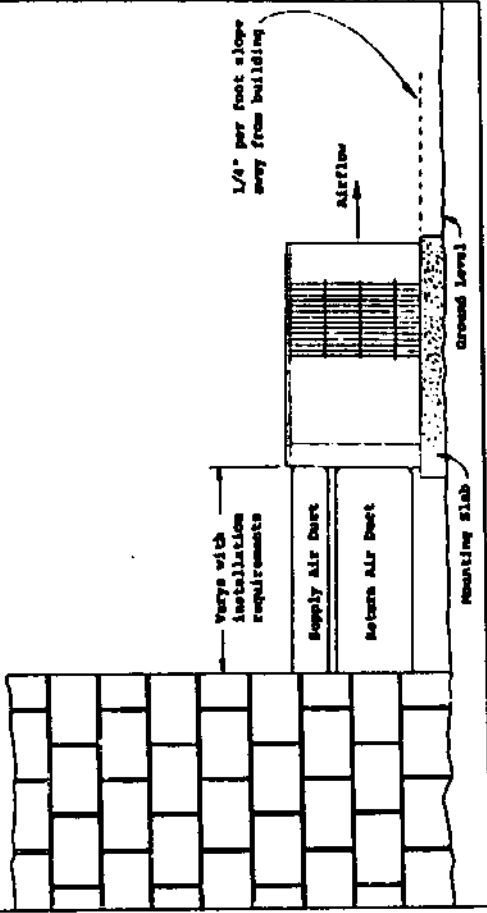

Figure 2

AIRFLOW AND SERVICE ACCESS CLEARANCES

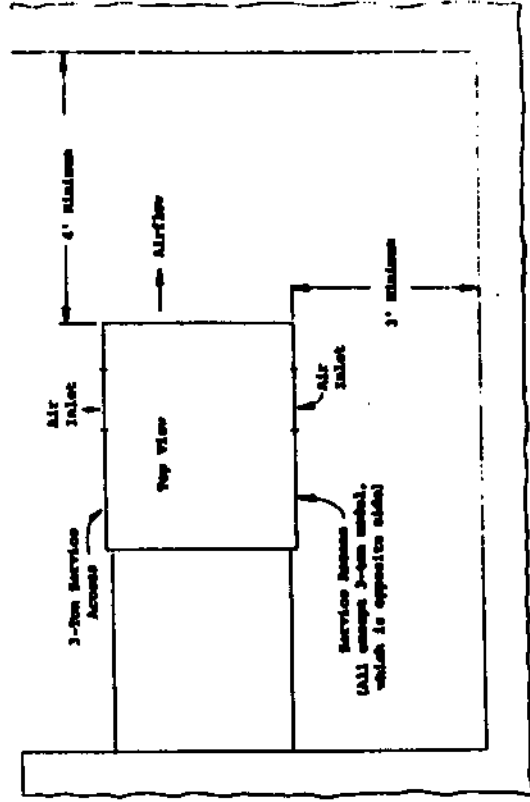
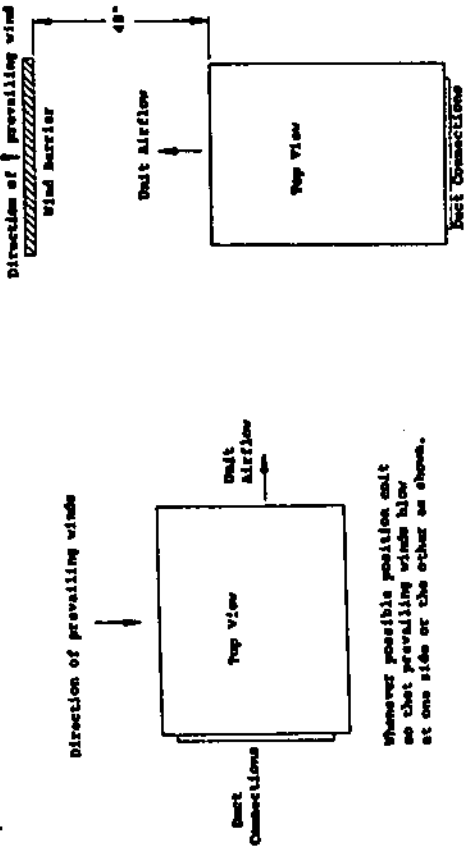

Figure 3

SCORP APPLICATION

(may also be required for ground level installations)



If outdoor unit must face prevailing wind, construct a wind barrier to secure proper airflow.

Whenever possible position unit so that prevailing winds blow at one side or the other as shown.

Figure 4

ELEVATED MOUNTING PLATFORMS

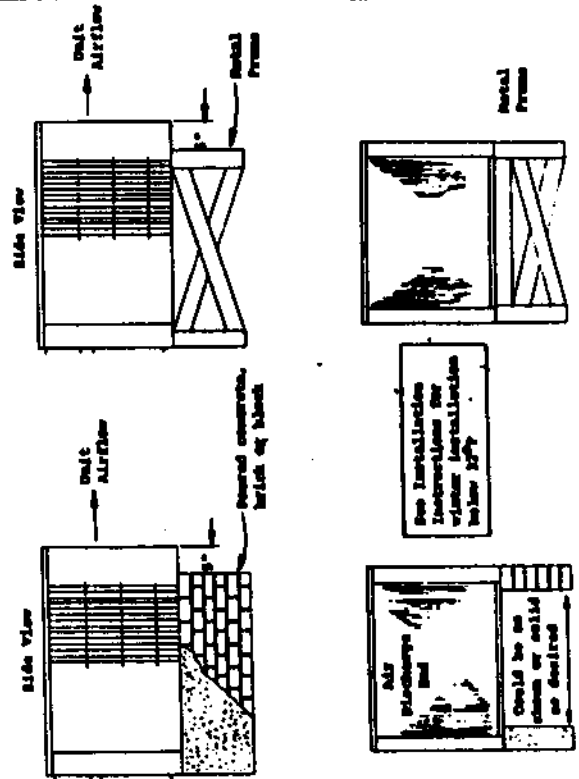

PARTS LIST
SINGLE PACKAGE HEAT PUMPS

1/85

Mfrs. Part No.	DESCRIPTION	2.5 Ton	3 Ton	3 Ton 3-Ph	3 Ton 3-Ph 460v
5202-003	Accumulator	x			
5202-004	Accumulator		x	x	x
*	Blower Housing 10-8	x	x	x	x
5152-013	Blower Wheel DD10-8A	x	x	x	x
8552-002	Capacitor - Fan & Blower 5/370	(2)	(2)	(2)	(2)
8552-035	Capacitor - Comp. 40/370V	x			
8552-028	Capacitor - Comp. 35/440V		x		
5811-034	Capillary Tube - Heat	x			
5811-034	Capillary Tube - Cool	(2)	(2)	(2)	(2)
5811-021	Capillary Tube - Heat		x	x	x
5651-036	Check Valve	x	x	x	x
5051-003	Condenser Coil	x	x	x	x
8000-052	Compressor CRG1-0250-PFV-270	x			
8000-058	Compressor CRJ3-0250-PFV-270		x		
8000-059	Compressor CRJ3-0300-TF5-270			x	
8000-060	Compressor CRJ3-0300-TFD-270				x
8401-007	Contactora - Compressor 1P25A	x	x		
8401-002	Contactora - Compressor			x	x
8408-004	Defrost Mounting Plate	x	x	x	x
8408-012	Defrost Thermostat	x	x	x	x
5060-037	Evaporator Coil	x			
5060-023	Evaporator Coil		x	x	x
5151-004	Fan Blade TP2026 cw	x	x	x	x
8103-014	Motor - Fan 1/5 hp				x
7051-001	Condenser Grille	x	x	x	x
7051-015	Wire Grille - Inlet	(2)	(2)	(2)	(2)
8604-010	High Pressure Switch	x	x	x	x
8105-016	Motor - Blower - 1/3 hp ccw				x
8105-024	Motor - Blower 1/3 hp ccw	x	x	x	
8103-009	Motor - Fan 1/5 hp	x	x	x	
8200-003	Motor Mount - Blower	x	x	x	x
8200-001	Motor Mount - Fan	x	x	x	x
5451-011	Motor Mounting Parts	x	x	x	x
8201-008	Relay - Blower	x	x	x	
8201-032	Relay - Blower				x
8201-024	Relay - Compressor Fault	x	x		
8201-047	Relay - Defrost	x	x	x	x
8201-013	Relay - Emergency Heat	x	x	x	x

*Please order by model number.

PARTS LIST
SINGLE PACKAGE HEAT PUMPS

6/84

Mfrs. Part No.	DESCRIPTION	2.5 Ton	3 Ton	3 Ton 3-Ph	3 Ton 3-Ph 460v.
5650-005	Reversing Valve	x			
5650-013	Reversing Valve		x	x	x
5650-008	Solenoid Coil	x	x	x	x
5210-004	Strainer	x	x	x	x
5210-002	Strainer	x	x	x	x
8607-010	Terminal Board 24V	x	x	x	x
8607-013	Terminal Block 230V	x	x		
8607-014	Terminal Block 230V			x	x
8612-012	Timer	x	x	x	x
8407-035	Transformer	x	x	x	x
8407-037	Transformer - Stepdown				x

Minimum net billing \$15.00. Supersedes all previous lists.
Subject to change without notice.

PARTS LIST
SINGLE PACKAGE HEAT PUMPS

6/84

Mfrs. Part No.	Description	3.5 Ton	3.5 Ton 3-Ph	4 Ton	4 Ton 3-Ph	5 Ton	5 Ton 3-Ph	3.5 Ton 460V 3-Ph	4 Ton 460V 3-Ph	5 Ton 460V 3-Ph
5202-005	Accumulator	x	x	x	x			x	x	
5202-008	Accumulator					x	x			x
*	Blower Housing	x	x	x	x	x	x	x	x	x
5152-045	Blower Wheel 10-9	x	x					x		
5152-015	Blower Wheel DD10-10A			x	x	x	x		x	x
8552-030	Capacitor - Comp. 40/440V	x		x						
8552-005	Capacitor - Blower 10/370V	x	x	x	x	x	x	x	x	x
8552-026	Capacitor - Fan 15/370V	x	x	x	x			x	x	
8552-004	Capacitor - Fan 7½/370V					x	x			x
8552-043	Capacitor - Comp. 45/370V					(2)				
5811-016	Capillary Tube - Cool	(2)	(2)					(2)		
5811-019	Capillary Tube - Heat	(2)	(2)					(2)		
5811-020	Capillary Tube - Cool			(2)	(2)				(2)	
5811-027	Capillary Tube - Heat			(2)	(2)				(2)	
5811-027	Capillary Tube - Cool					(2)	(2)			(2)
5811-032	Capillary Tube - Heat					(2)	(2)			(2)
5651-036	Check Valve	x	x	x	x	x	x	x	x	x
5051-029	Condenser Coil	x	x	x	x	x	x	x	x	x
8000-063	Compressor CRK1-0325-PFV-270	x								
8000-064	Compressor CRK1-0325-TF5-270		x							
8000-065	Compressor CRK1-0325-TFD-270							x		
8000-081	Compressor AV168ET-005-A4			x						
8000-082	Compressor AV169RT-012-A4				x					
8000-083	Compressor AV169TT-013-A4								x	
8000-074	Compressor AG134ET-002-A4					x				
8000-075	Compressor AG134RT-002-A4						x			
8000-049	Compressor AG133UT-003-A4									x
8401-007	ContactoR R8242A1008	x								
8401-002	ContactoR 30D0-30		x		x			x	x	x
8401-003	ContactoR R8243A1007			x						
8401-016	ContactoR R8243A1189					x				
8401-011	ContactoR 30E0-30						x			
8408-004	Defrost Mounting Plate	x	x	x	x	x	x	x	x	x
8408-012	Defrost Thermostat	x	x	x	x	x	x	x	x	x
5060-025	Evaporator Coil	x	x	x	x	x	x	x	x	x
5151-029	Fan Blade T10H08-2436 ccw	x	x	x	x			x	x	
5151-030	Fan Blade T10H08-2428 ccw					x	x			x
7051-005	Condenser Grille	x	x	x	x	x	x	x	x	x
7051-007	Wire Grille - Inlet	(2)	(2)	(2)	(2)	(2)	(2)	(2)	(2)	(2)

*Please order by model number.

PARTS LIST
SINGLE PACKAGE HEAT PUMPS

11/84

Mfrs. Part No.	Description	3.5 Ton	3.5 Ton 3-Ph.	4 Ton	4 Ton 3-Ph.	5 Ton	5 Ton 3-Ph.	3.5 Ton 460V	4 Ton 460V	5 Ton 460V
8406-010	High Pressure Switch	x	x	x	x	x	x	x	x	x
8106-015	Motor - Blower 1/2 hp	x	x	x	x	x	x	x	x	x
8105-021	Motor - Fan 1/3 hp	x	x	x	x	x	x	x	x	x
8106-016	Motor - Fan 1/2 hp					x	x			x
8200-003	Motor Mount - Blower	x	x	x	x	x	x	x	x	x
8200-004	Motor Mount - Fan	x	x	x	x	x	x	x	x	x
5451-011	Motor Mounting Parts	x	x	x	x	x	x	x	x	x
8201-008	Relay - Blower	x	x	x	x	x	x	x	x	x
8201-024	Relay - Compressor Fault	x		x		x				x
8201-047	Relay - Defrost	x	x	x	x	x	x	x	x	x
8201-013	Relay - Emergency Heat	x	x	x	x	x	x	x	x	x
5650-006	Reversing Valve	x	x	x	x			x	x	
5650-010	Reversing Valve					x	x			x
5650-008	Reversing Valve Solenoid Coil	x	x	x	x	x	x	x	x	x
5210-005	Strainer	(2)	(2)	(2)	(2)	(2)	(2)	(2)	(2)	(2)
8607-010	Terminal Board	x	x	x	x	x	x	x	x	x
8607-013	Terminal Block	x		x		x		x	x	x
8607-014	Terminal Block		x		x		x		x	x
8612-012	Timer 30/60 Min.	x	x	x	x	x	x	x	x	x
8407-035	Transformer	x	x	x	x			x	x	x
8407-004	Transformer - Stepdown							x	x	x
8201-045	Relay - Time Delay					x				
8407-036	Transformer					x				
8614-027	Buss Fuseholder					x				
8614-030	Buss 3 amp fuse					x				

Minimum net billing \$15.00. Supersedes all previous lists.
Subject to change without notice.

PACKAGED HEAT PUMP MODEL 2.5 TON

These curves are based upon 80°F DB, 67°WB R.A. Temp. and Rated CFM (airflow) across the evaporator coil and should be used for reference purposes only. Special information can be found under section titled "Refrigerant Charge" elsewhere in manual. If there is any doubt as to correct operating charge being in the system, the charge should be removed, system

HIGH SIDE (DISCHARGE LINE) PRESSURE--PSIG

LOW SIDE PRESSURE--PSIG
(SUCTION LINE)

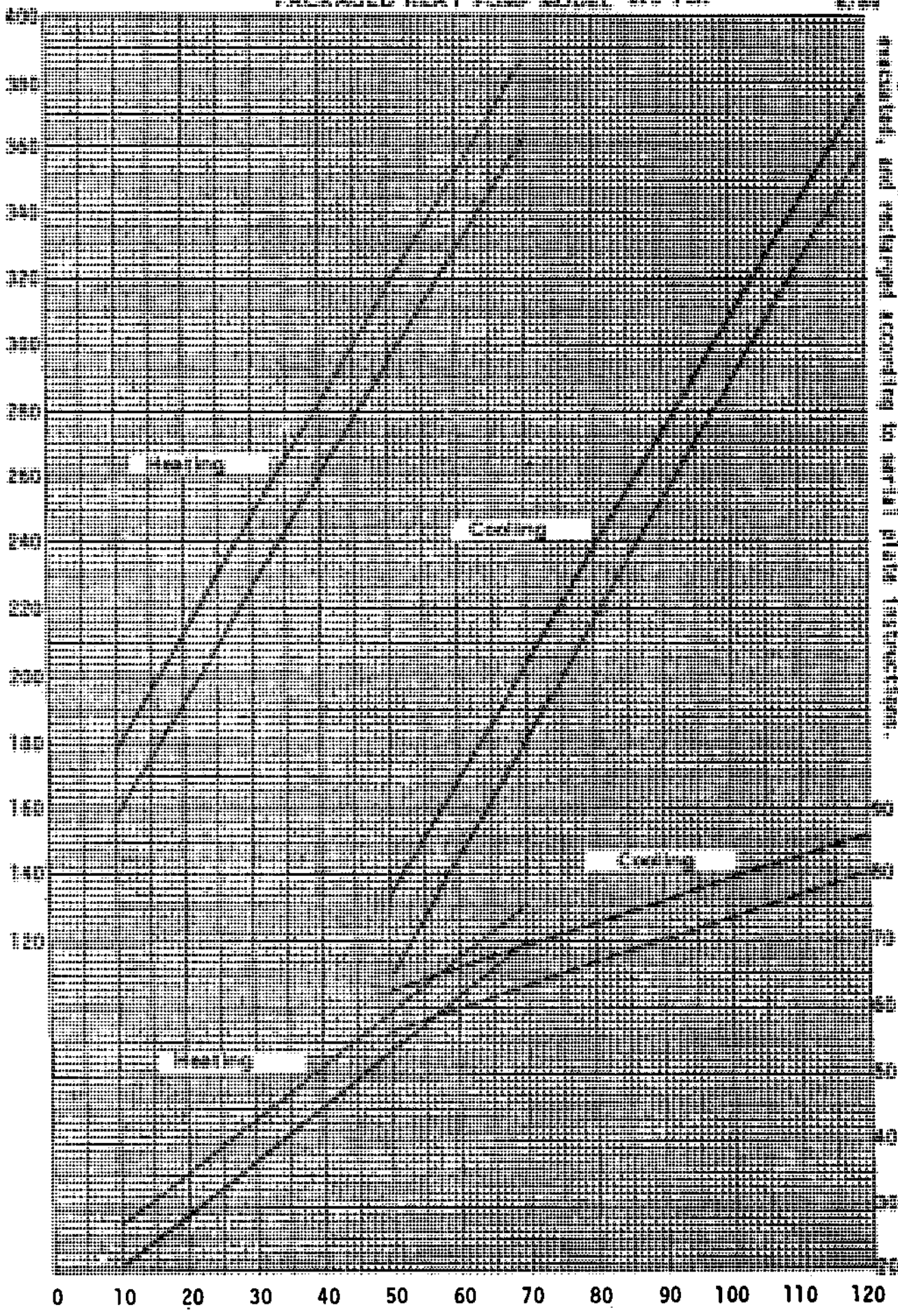

AIR TEMPERATURE ENTERING OUTDOOR COIL--DEGREE F.

PACKAGED HEAT PUMP MODEL 3 TON

6714

These curves are based upon 80°DB, 67°WB R.A. Temp. and Rated CFM (airfl) across the evaporator coil and should be used for reference purposes only. Special information can be found under section titled "Refrigerant Charge" elsewhere in manual. If there is any doubt as to correct operating charge being in the system, the charge should be removed, system evacuated, and recharging procedure followed.

HIGH SIDE (DISCHARGE LINE) PRESSURE--PSIG

LOW SIDE PRESSURE--PSIG
(SUCTION LINE)

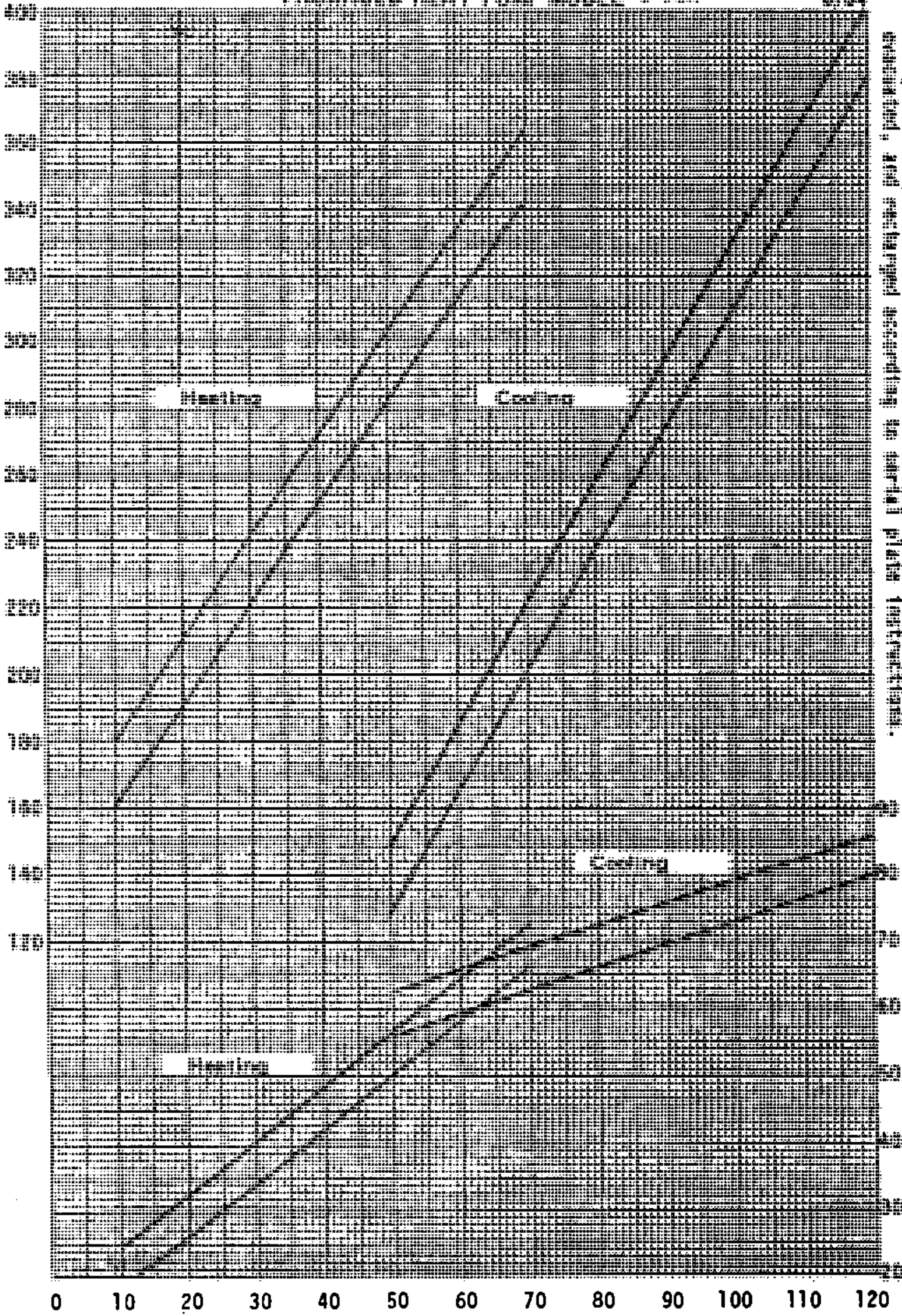

AIR TEMPERATURE ENTERING OUTDOOR COIL--DEGREE F.

Cooling curves are based upon 80DB, 67WB R.A. Temp. and Rated CFM (air-flow) across the evaporator coil and should be used for reference purposes only. Specific information can be found under section titled, "Refrigerant Charge" elsewhere in manual. If there is any doubt as to correct operating charge being in the system, the charge should be removed, system evacuated, and recharged according to serial plate instructions. Heating curves are based upon 70DB R.A. Temp.

HIGH SIDE (DISCHARGE LINE) PRESSURE -- PSIG

Low Side (Suction Line) Pressure -- PSIG

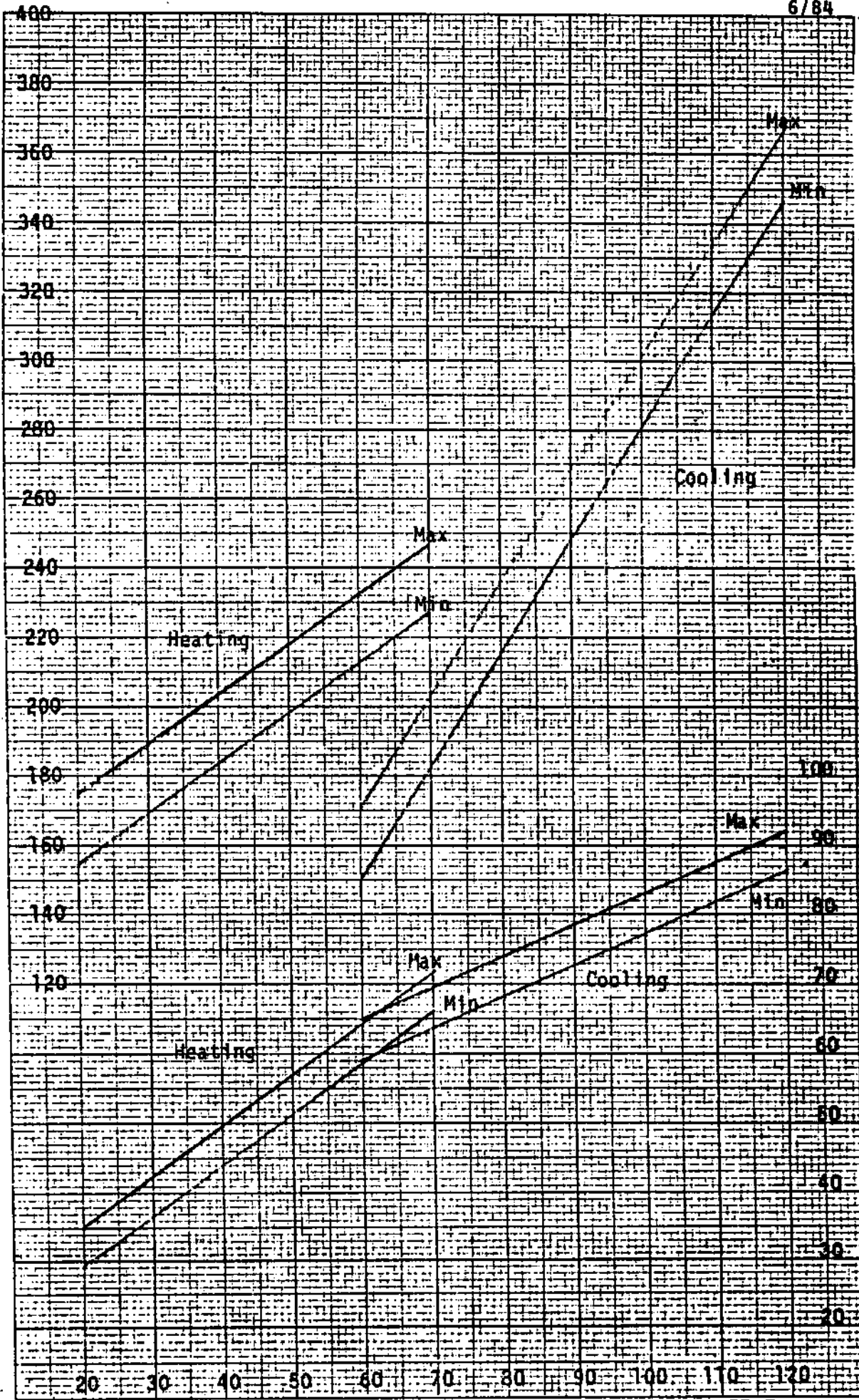

AIR TEMPERATURE ENTERING OUTDOOR COIL - DEGREE F

PACKAGED HEAT PUMP MODEL A Ton

These curves are based upon 80°DB, 67°WB R.A. Temp. and Rated CFM (airfl) across the evaporator coil and should be used for reference purposes only. Special information can be found under section titled "Refrigerant Charge" elsewhere in manual. If there is any doubt as to correct operating charge being in the system, the charge should be removed, system

HIGH SIDE (DISCHARGE LINE) PRESSURE--PSIG

LOW SIDE PRESSURE--PSIG
(SUCTION LINE)

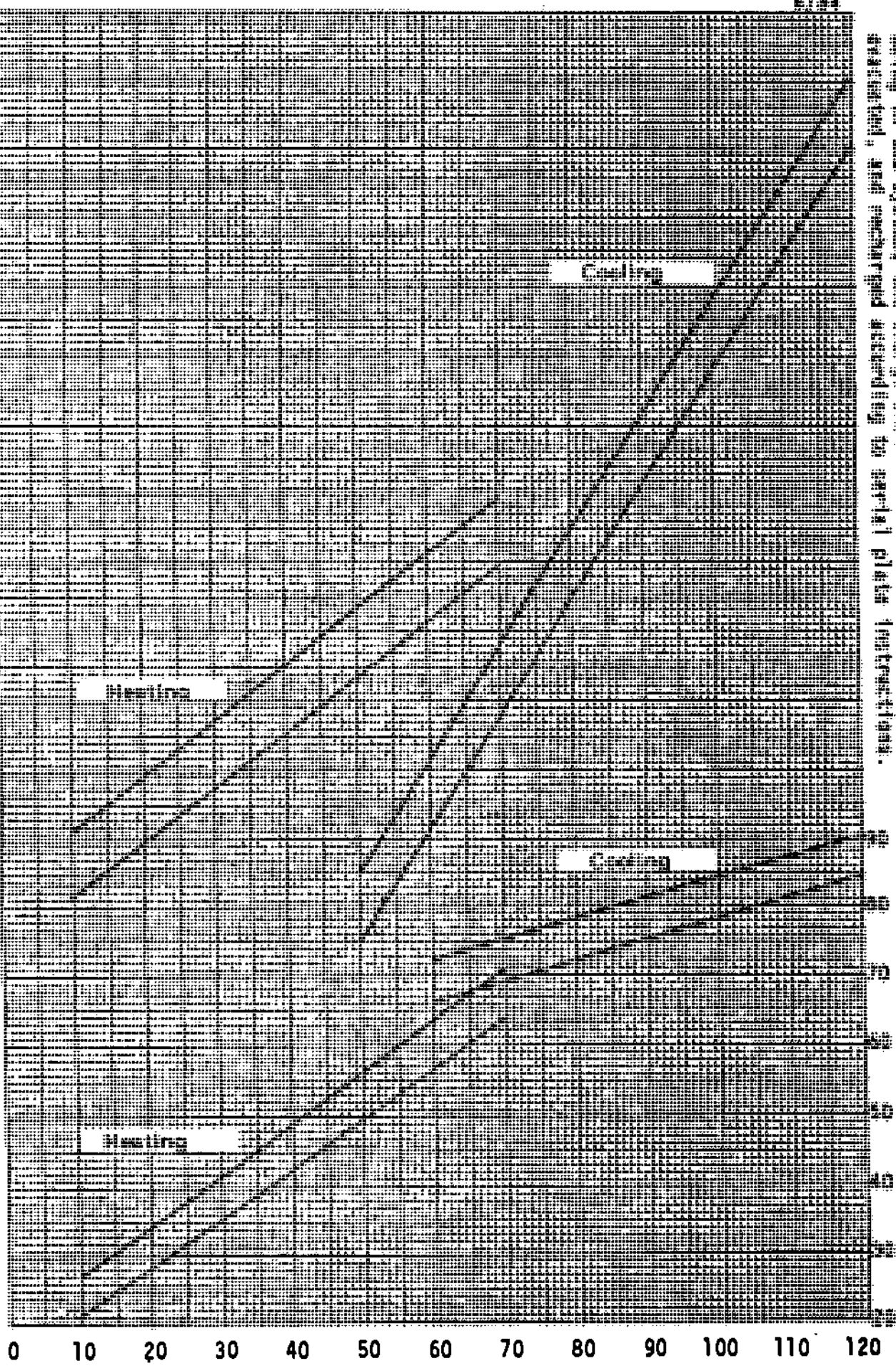

AIR TEMPERATURE ENTERING OUTDOOR COIL--DEGREE F.

6/84

Cooling curves are based upon 80DB, 67WB R.A. Temp. and Rated CFM (air-flow) across the evaporator coil and should be used for reference purposes only. Specific information can be found under section titled, "Refrigerant Charge" elsewhere in manual. If there is any doubt as to correct operating charge being in the system, the charge should be removed, system evacuated, and recharged according to serial plate instructions. Heating curves are based upon 70DB R.A. Temp.

HIGH SIDE (Suction Line) PRESSURE -- PSIG

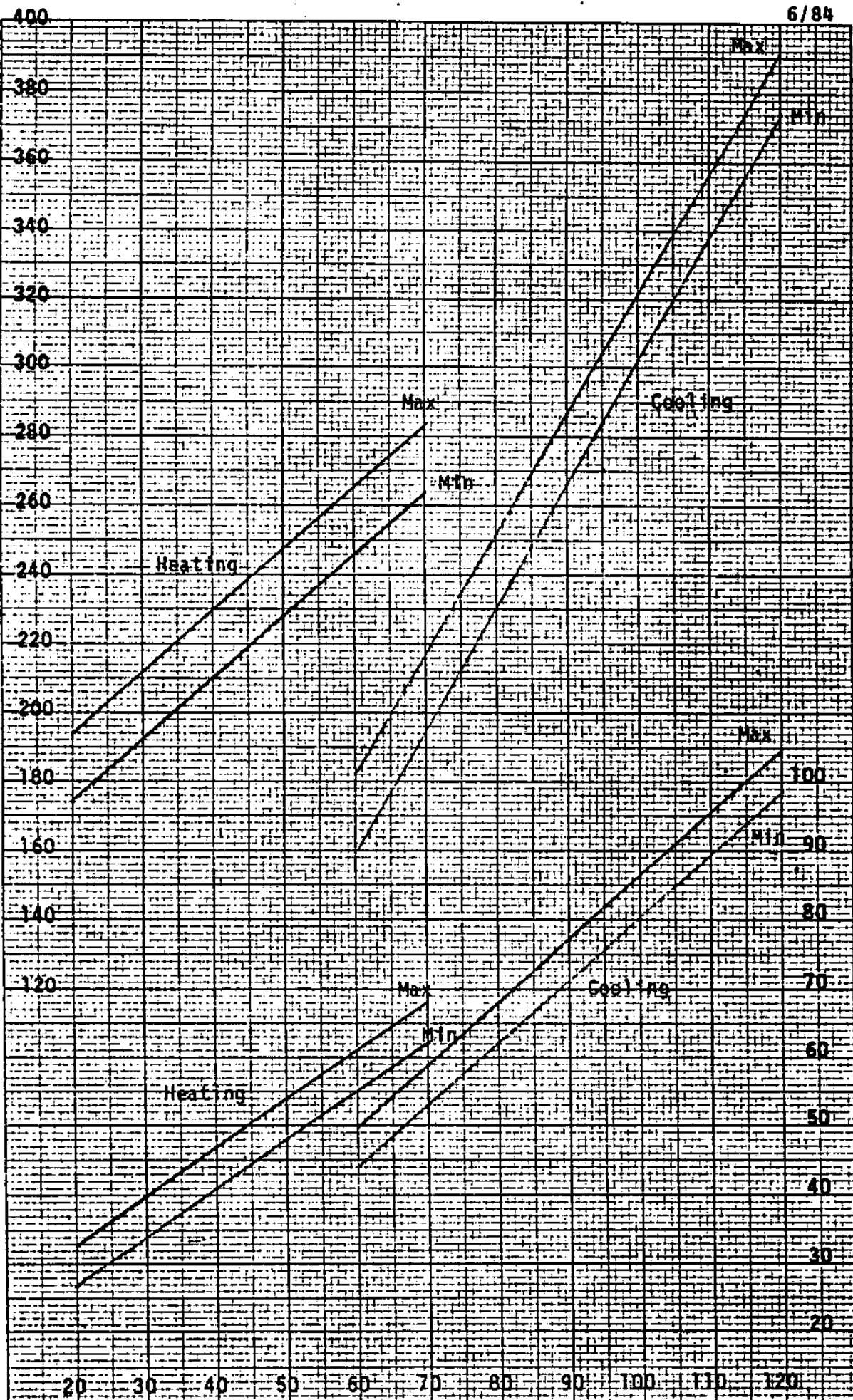

Low Side (Suction Line) pressure -- PSIG

AIR TEMPERATURE ENTERING OUTDOOR COIL - DEGREE F

70 x 20 PER INCH

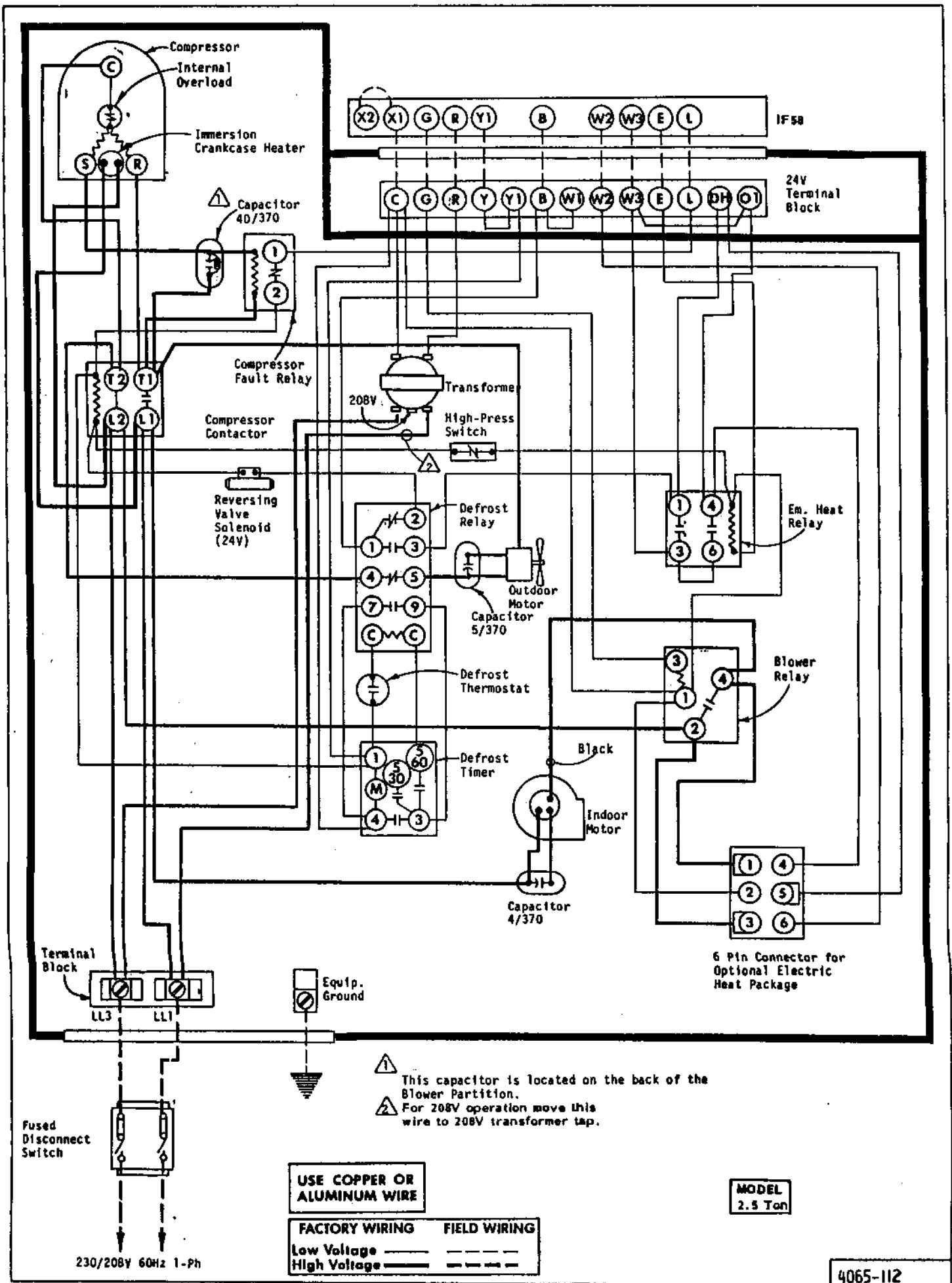

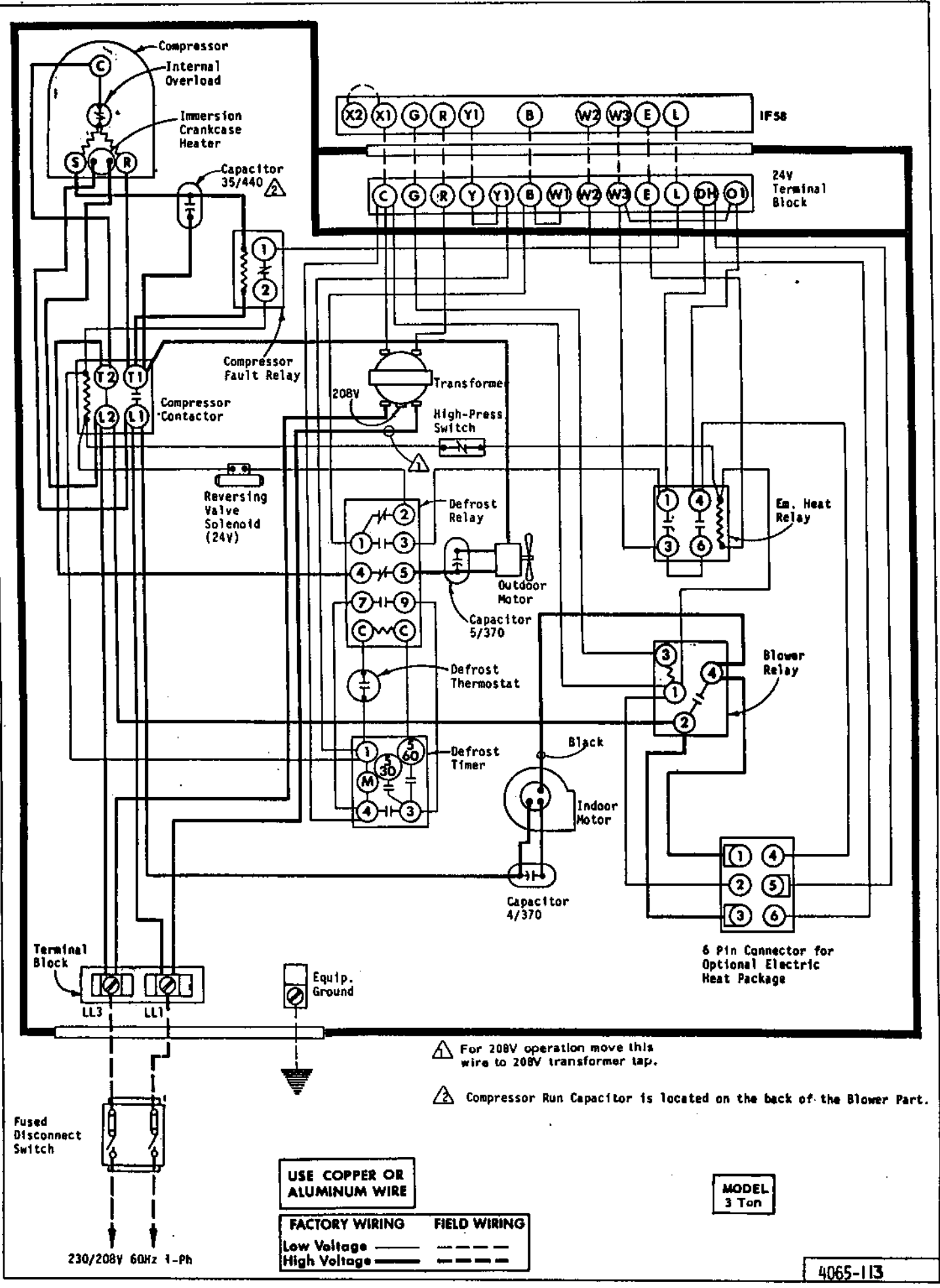

⚠ For 208V operation move this wire to 208V transformer tap.

⚠ Compressor Run Capacitor is located on the back of the Blower Part.

Fused Disconnect Switch

230/208V 60Hz 1-Ph

USE COPPER OR ALUMINUM WIRE

	FACTORY WIRING	FIELD WIRING
Low Voltage	—————	- - - - -
High Voltage	—————	- - - - -

MODEL
3 Ton

4065-113

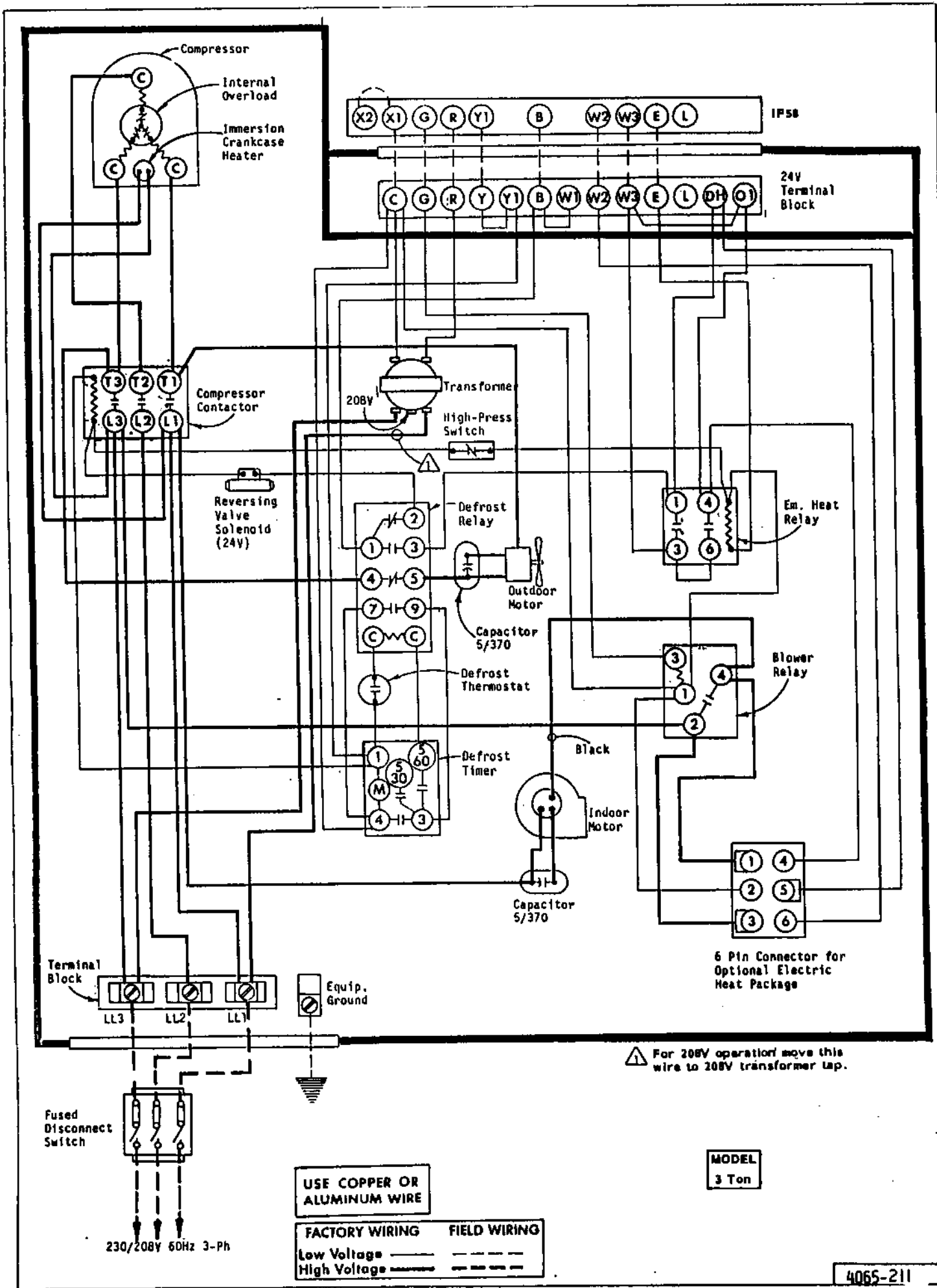

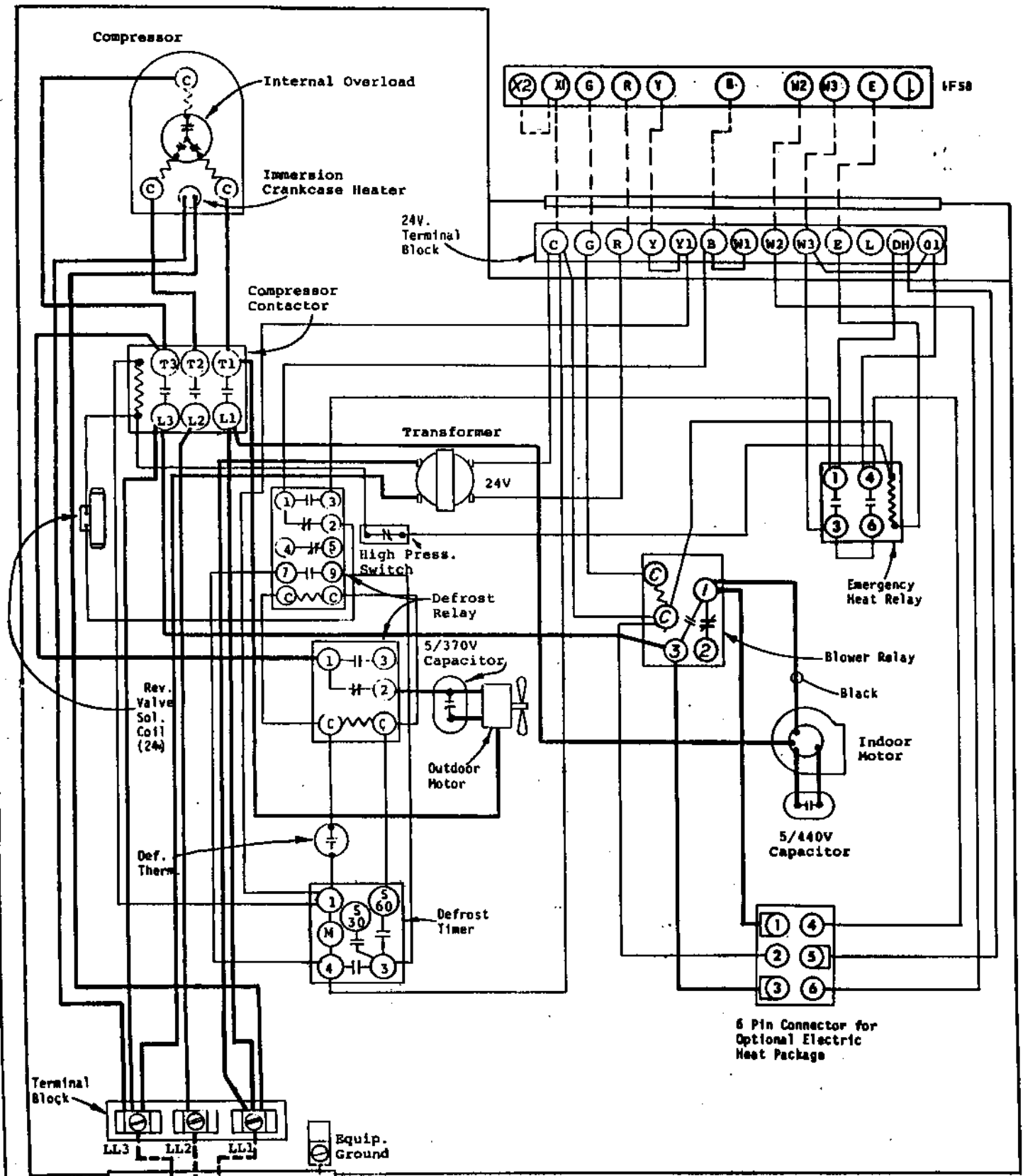

FACTORY WIRING	FIELD WIRING
Low Voltage	-----
High Voltage	-----

MODEL
3 Ton

USE COPPER OR ALUMINUM WIRE

Fused Disconnect Switch

460-60-3

4065-311

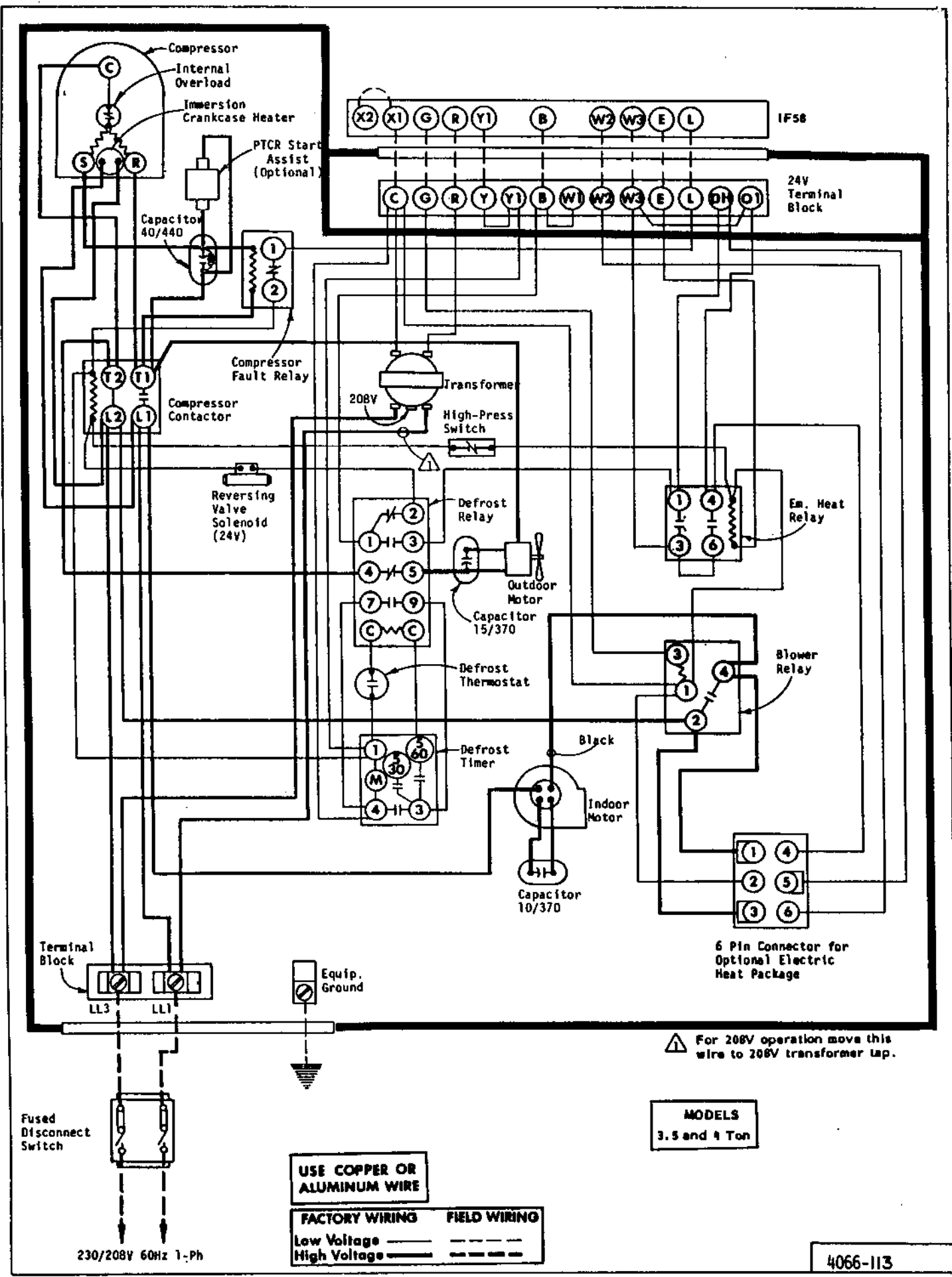

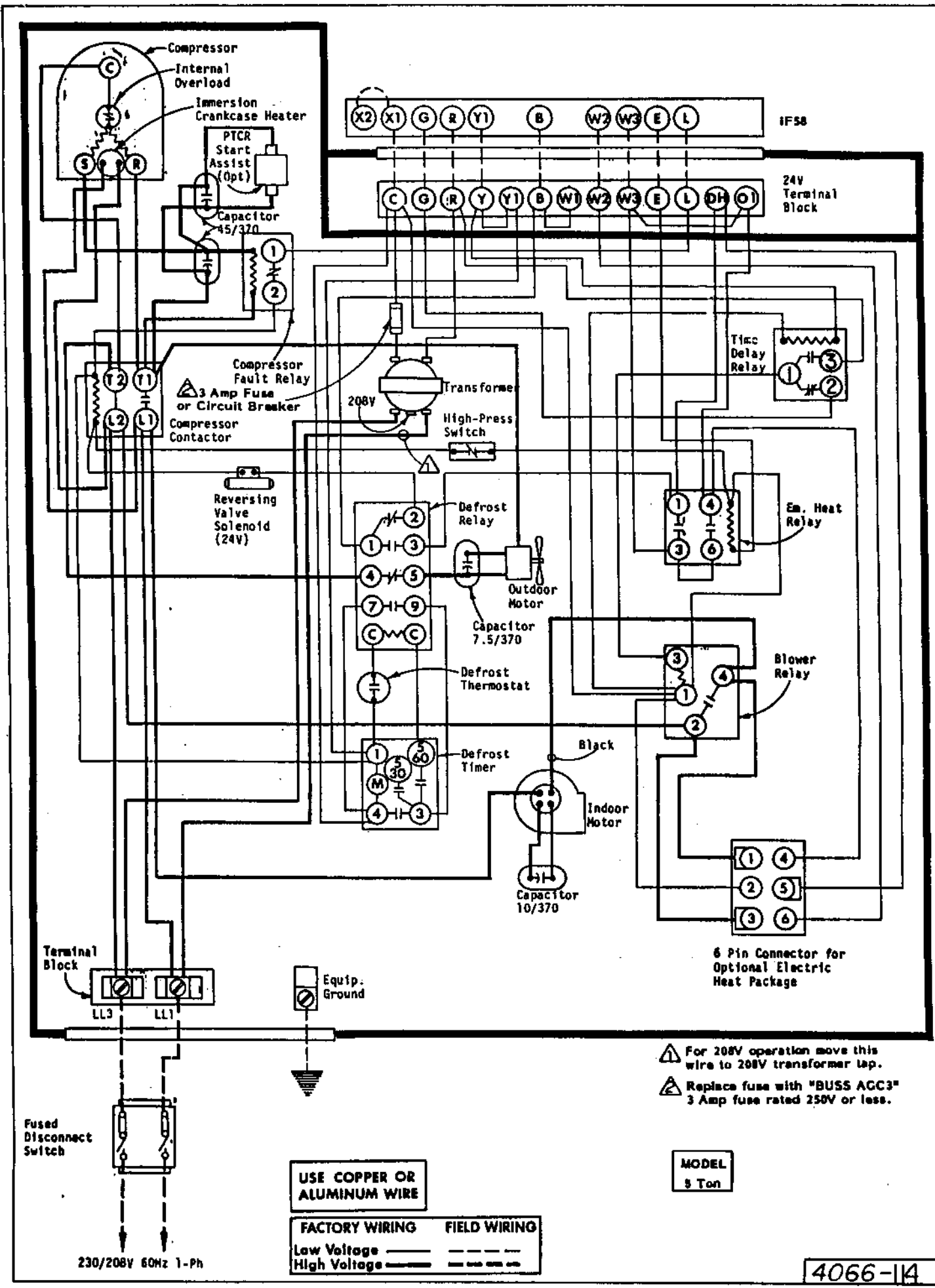

- ⚠ For 208V operation move this wire to 208V transformer tap.
- ⚠ Replace fuse with "BUSS AGC3" 3 Amp fuse rated 250V or less.

MODEL
5 Ton

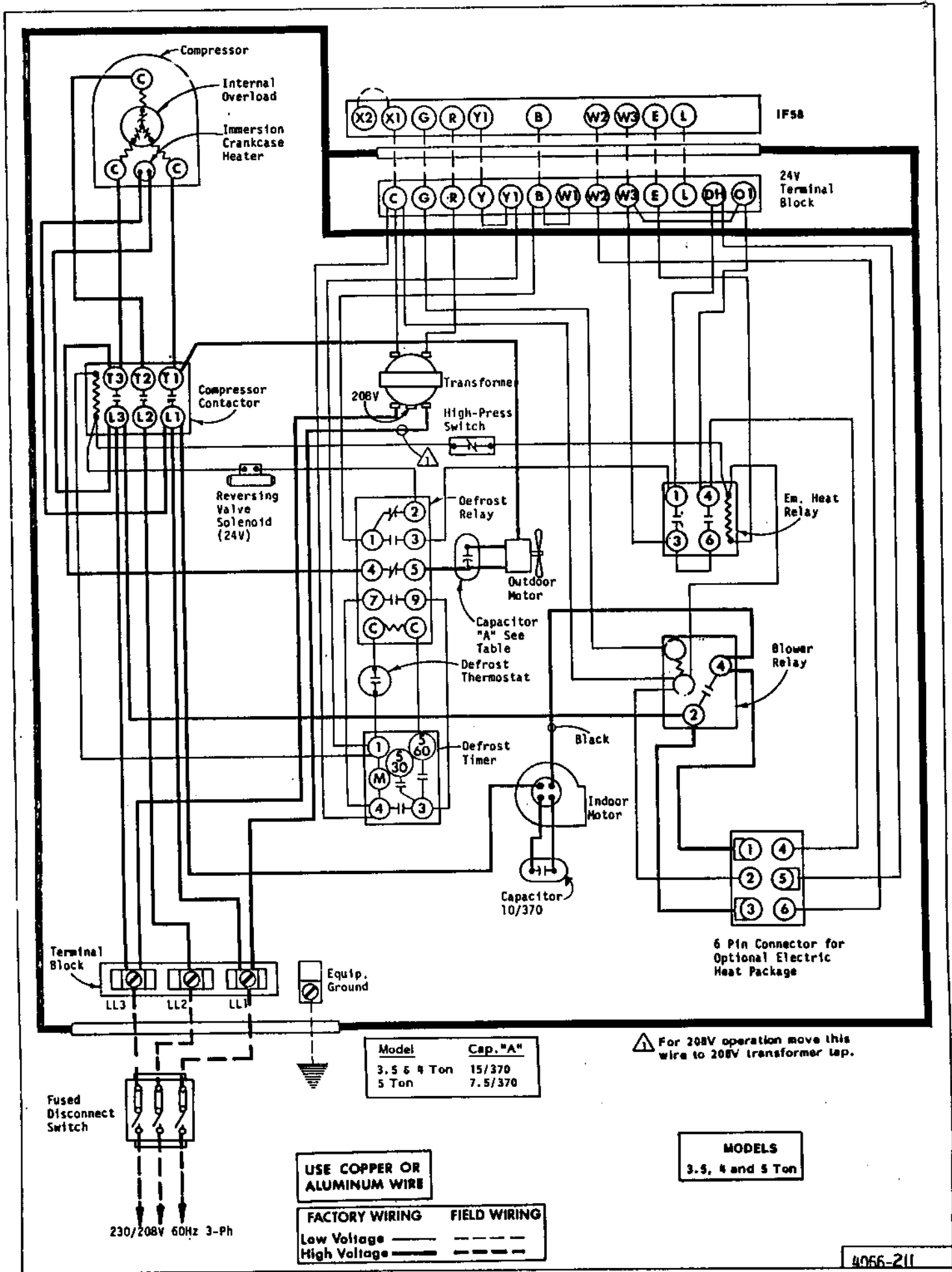

Model	Cap. "A"
3.5 & 4 Ton	15/370
5 Ton	7.5/370

⚠ For 208V operation move this wire to 208V transformer tap.

USE COPPER OR ALUMINUM WIRE

MODELS
3.5, 4 and 5 Ton

	FACTORY WIRING	FIELD WIRING
Low Voltage	_____	-----
High Voltage	_____	-----

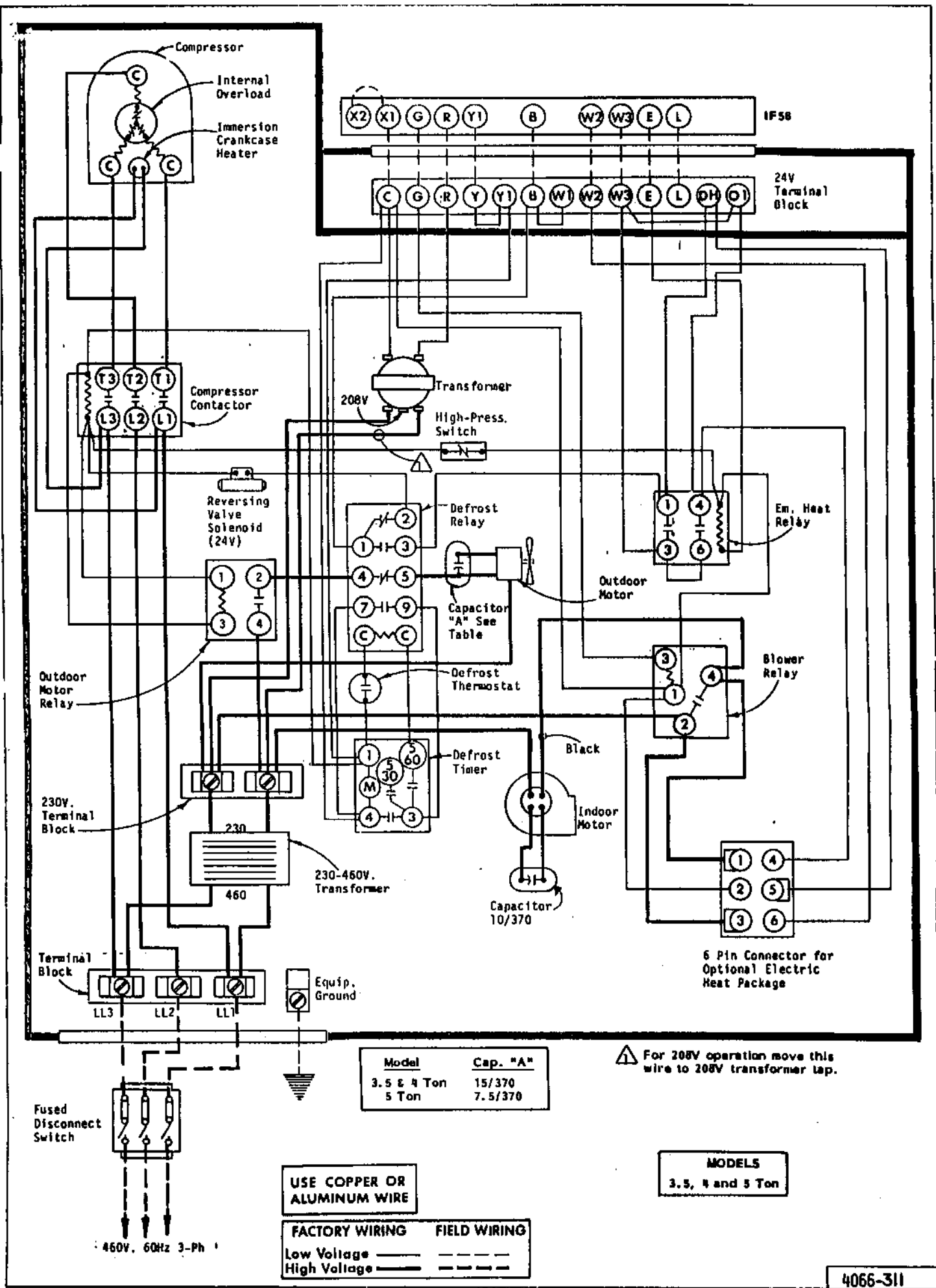

Model	Cap. "A"
3.5 & 4 Ton	15/370
5 Ton	7.5/370

⚠ For 208V operation move this wire to 208V transformer tap.

MODELS
3.5, 4 and 5 Ton

USE COPPER OR ALUMINUM WIRE

	FACTORY WIRING	FIELD WIRING
Low Voltage	————	- - - -
High Voltage	————	- - - -