

# MODELS

2 Ton

2½ Ton

3 Ton

4 Ton

5 Ton

**PACKAGED AIR CONDITIONER**

**INSTALLATION INSTRUCTIONS**

**FOR RESIDENTIAL AND COMMERCIAL  
HEATING / COOLING APPLICATIONS**

**ELECTRICAL DATA**

Model	Rated Volts & PH	Operating Voltage Range	Max. Unit Amps	Req'd Maximum External Fuses or Ckt. Breaker*	Minimum Circuit Ampacity	Field Power Wiring**	Ground Wire Size**
				Ckt. A	Ckt. A	Ckt. A	Ckt. A
2 Ton	230/208-1	197-253	18.8	30	20	12	10
2 1/2 Ton	230/208-1	197-253	20.4	40	25	10	10
3 Ton	230/208-1	197-253	22.4	40	27	10	10
3 Ton	230/208-3	187-253	16.4	30	19.4	12	10
3 Ton	460-3	414-506	8.7	15	15.0	14	14
4 Ton	230/208-1	197-253	30.0	60	37	8	10
4 Ton	230/208-3	187-253	22.5	40	27	10	10
4 Ton	460-3	414-506	12.5	20	15	14	14
5 Ton	230/208-1	197-253	34.2	60	44	6	10
5 Ton	230/208-3	187-253	27.5	50	34.0	8	10
5 Ton	460-3	414-506	13.8	25	17.0	14	12

\*Maximum time delay fuse or HACR type circuit breaker. HACR type not applicable to 460 volt.

\*\*60°C copper wire size, basic unit only.

+460 volt not U.L. listed.

**OPTIONAL FIELD-INSTALLED ELECTRIC HEATER TABLE**

Heater Package Model No.	Unit Volts Phase	Htr. Kw & Capacity @ 240V (or 480V if applicable)		Heater Kw & Capacity @ 208 Volts		@ 240V or 480V as applicable Htr. Amps	Heater Internal Fuses	Circuit B					
		Kw	Btuh	Kw	Btuh			Number Field Ckts.	Minimum Circuit Ampacity	Max. Over-Current Protection ①	Field Power Wiring ②	Ground Wire Size ③	
EH3PA-1-5A	240/208-1	5	17,100	3.75	12,800	20.8	30/60	1	26	30	10	10	
EH3PA-1-8A	240/208-1	8	27,300	6	20,500	33.3		1	42	45	6	10	
EH3PA-1-10A	240/208-1	10	34,100	7.5	26,000	41.7		1	53	60	6	10	
EH3PA-1-15A	240/208-1	15	51,200	11.25	38,400	62.5		1	79	80	3	8	
EH3PA-3-9B	240/208-3	9	30,700	6.75	23,000	21.7		1	28	30	10	10	
EH3PA-3-15B	240/208-3	15	51,200	11.25	38,400	36.2		1	46	50	6	10	
EH3PA-3-9C	460-3	9	30,700	6.75	23,000	10.8		1	15	15	14	14	
EH3PA-3-15C	460-3	15	51,200	11.25	38,400	18.0		1	23	25	10	10	
EH5PA-1-5A	240/208-1	5	17,100	3.75	12,800	20.8		60/60	1	26	30	10	10
EH5PA-1-10A	240/208-1	10	34,100	7.5	26,000	41.7			1	53	60	6	10
EH5PA-1-15A	240/208-1	15	51,200	11.25	38,400	62.5			1	79	80	3	8
EH5PA-1-20A	240/208-1	20	68,200	15	51,200	83.2			1	104	110	2	6
EH5PA-3-9B	240/208-3	9	30,700	6.75	23,000	21.7	1		28	30	10	10	
EH5PA-3-15B	240/208-3	15	51,200	11.25	38,400	36.2	1		46	50	6	10	
EH5PA-3-18B	240/208-3	18	61,400	13.5	46,100	43.4	1		55	60	6	10	
EH5PA-3-9C	460-3	9	30,700	6.75	23,000	10.8	1		15	15	14	14	
EH5PA-3-15C	460-3	15	51,200	11.25	38,400	18.0	1		23	25	10	10	
EH5PA-3-18C	460-3	18	61,400	13.5	46,100	21.7	1		28	30	10	10	

① Time Delay fuses or "HACR Type" circuit breakers must be used for 60 and smaller sizes. Standard fuses or circuit breakers are suitable for sizes 70 and larger. 480V circuit breakers are not HACR type.

② Based on wire suitable for 60°C. Other wiring materials must be rated for marked "Minimum Circuit Ampacity" or greater.

③ Based upon Table 250-95 of N.E.C. 1984. See electrical data for basic heat pump for Ckt. A wiring specification requirements.

④ For ampacities over 100 amperes use wire suitable for at least 75°C.

**IMPORTANT:** While this electrical data is presented as a guide, it is important to electrically connect, properly size fuses and conductor wires in accordance with the National Electrical Code and all existing local codes.

**OPTIONAL FIELD-INSTALLED HEATER PACKAGES ARE ONLY TO BE USED WITH THE AIR CONDITIONER MODELS AS INDICATED BELOW**

Heater Model No.	Volts & Ph	2 Ton	2 1/2 Ton	3 Ton	3 Ton	3 Ton 460V	4 Ton	4 Ton	4 Ton	4 Ton 460V	5 Ton	5 Ton	5 Ton 460V
EH3PA-1-5A	240/1	1	1	1	*	*							
EH3PA-1-8A		1	1	1	*	*							
EH3PA-1-10A		1	1	1	*	*							
EH3PA-1-15A		1	1	1	*	*							
EH3PA-3-9B	240/3	*	*	*	1	*							
EH3PA-3-15B		*	*	*	1	*							
EH3PA-3-9C		*	*	*	1	*							
EH3PA-3-15C	480/3	*	*	*	1	*							
EH5PA-1-5A	240/1						1	*	*	*	1	*	*
EH5PA-1-10A							1	*	*	*	1	*	*
EH5PA-1-15A							1	*	*	*	1	*	*
EH5PA-1-20A							1	*	*	*	1	*	*
EH5PA-3-9B	240/3						*	1	*	*	1	*	*
EH5PA-3-15B							*	1	*	*	1	*	*
EH5PA-3-18B							*	1	*	*	1	*	*
EH5PA-3-9C	480/3						*	*	*	1	*	*	1
EH5PA-3-15C							*	*	*	1	*	*	1
EH5PA-3-18C							*	*	*	1	*	*	1

1 - Standard application - Heater volts and phase same as basic unit.

\* - Alternate application - Heater volts and phase different from basic unit.

## IMPORTANT

The equipment covered in this manual is to be installed by trained, experienced service and installation technicians. All duct work, supply and return, must be properly sized for the design air flow requirement of the equipment. ACCA is an excellent guide to proper sizing. All duct work or portions thereof not in the conditioned space, should be properly insulated in order to both conserve energy and prevent condensation or moisture damage.

## SHIPPING DAMAGE

Upon receipt of equipment, the carton should be checked for external signs of shipping damage. If damage is found, the receiving party must contact the last carrier immediately, preferably in writing, requesting inspection by the carrier's agent.

## GENERAL

The refrigerant system is completely assembled and charged. All internal wiring is complete.

The unit is designed for use with or without duct work. Flanges are provided for attaching the supply and return ducts.

These instructions explain the recommended method to install the air cooled self-contained unit and the electrical wiring connections to the unit.

These instructions and any instructions packaged with any separate equipment required to make up the entire air conditioning system should be carefully read before beginning the installation. Note particularly "Starting Procedure" and any tags and/or labels attached to the equipment.

While these instructions are intended as a general recommended guide, they do not supersede any national and/or local codes in any way. Authorities having jurisdiction should be consulted before the installation is made.

## INSTALLATION

Size of unit for a proposed installation should be based on heat loss calculation made according to methods of National Warm Air Heating and Air Conditioning Association. The air duct should be installed in accordance with the Standards of the National Fire Protection Association for the Installation of Air Conditioning and Ventilating Systems of Other Than Residence Type, NFPA No. 90A, and Residence Type Warm Air Heating and Air Conditioning Systems, NFPA No. 90B. Where local regulations are at a variance with instructions, installer should adhere to local codes.

## LOCATION

The unit must be located outside, or in a well ventilated area. It must not be in the space being heated or cooled. A sound absorbing material should be considered if the unit is to be installed in such a position or location that might cause transmission of sound or vibration to the living area or adjacent buildings.

## TYPICAL INSTALLATIONS

1. Roof-Mounted - The unit is mounted on a sturdy base on the roof of the building. Return air to the unit is brought through a single return grille (grilles with built-in filters are best, since they enable easy access for filter changing). Return air ducts are attached to the lower section of the front panel. Supply air is brought from the unit to attic duct work or to a furred down hall. Supply air duct is attached to the top of the front panel. CAUTION: All outdoor duct work must be thoroughly insulated and weatherproofed. All attic duct work must be thoroughly insulated. One inch thick insulation with suitable vapor barrier is recommended for both outdoor and attic runs. In roof-top installation, as in all installations, the unit must be level from side to side. However, the unit should have a pitch along the length to assure complete external drainage of precipitation and of defrost condensate.

2. Crawl Space - Duct work installed in crawl space must be well insulated and provided with a vapor barrier. In addition, the crawl space must be thoroughly ventilated and provided with a good vapor barrier as a ground cover. It is most desirable to install the unit outdoors, rather than inside the crawl space, so that it will be readily accessible for service. In addition, it is necessary to dispose of the condensate from the outdoor coil on the heating cycle, and this is virtually impossible with the unit installed inside the crawl space.
3. Slab Mounted at Ground Level - This type installation is ideal for homes with slab floor construction, where a roof-mounted unit is not desired. The supply and return duct work can be run through a furred closet space.
4. Thru-The-Wall - This type installation requires a suitable framework to be fabricated, capable of withstanding the unit weight. Normally the unit will be installed so as to minimize supply and return duct work.
5. Other Installations - Many other installations are possible with the packaged air conditioner. No matter what the installation, always consider the following facts:
  - a. Insure that the discharge air is not obstructed in any way so as to cause operation difficulties.
  - b. The indoor coil drain pan is equipped with a coupling that must be piped through a condensate drain trap to a suitable drain.
  - c. Always mount the unit in such a position that it may be easily reached for servicing and maintenance.
  - d. Insure that the unit is clear so that proper air flow over the outdoor coil will be maintained.

RATED CFM AND E.S.P. (WET COIL - COOLING)			
Model	Rated CFM	Rated E.S.P.	Recommended Airflow Range
2 Ton	800	.35	720 - 880
2½ Ton	1150	.35	1025 - 1275
3 Ton	1275	.15	1150 - 1400
4 Ton	1700	.20	1520 - 1850
5 Ton	1775	.20	1500 - 1850

## WIRING - MAIN POWER

Refer to the unit rating plate for wire sizing information and maximum fuse or "HACR Type" circuit breaker size. Each outdoor unit is marked with a "Minimum Circuit Ampacity." This means that the field wiring used must be sized to carry that amount of current. If field installed heaters are added to the basic unit, a second, separate power supply circuit will be required. The heater rating plate located adjacent to the basic unit rating plate will show the appropriate circuit ampacity, fuse size, etc. (Also see "Electrical Data" on page 1). Some models are suitable only for connection with copper wire, while others can be wired with either copper or aluminum wire. Each unit and/or wiring diagram will be marked "Use Copper Conductors Only" or "Use Copper or Aluminum Conductors." These instructions MUST BE adhered to. Refer to the National Electrical Code for complete current-carrying capacity data on the various insulation grades of wiring material.

The electrical data lists fuse and wire sizes (60°F copper) for all models, including the most commonly used heater sizes. Also shown are the number of field power circuits required for the various models with heaters.

The unit rating plate lists "Maximum Time Delay Fuse" or "HACR Type" circuit breaker that is to be used with the equipment. The correct size must be used for proper circuit protection and also to assure that there will be no nuisance tripping due to the momentary high starting current of the compressor motor.

## PRESSURE SERVICE PORTS

High and low pressure service ports are installed on all units so that the system operating pressures can be observed. Pressure curves can be found later in the manual covering all models on both cooling and heating cycles. It is imperative to match the correct pressure curve to the unit by model number.

## AIR FILTERS

Air filters for the return air side of the system are not provided as part of the basic piece of equipment because of the various types of application for these models, and must be field supplied and installed as part of the final installation.

Prior thought should be given to return air location and placement of the air filter(s). The air filter(s) must be of adequate size and readily accessible to the operator of the equipment. Filters must be adequate in size and properly maintained for proper operation. If this is not done, excessive energy use, poor performance, and multiple service problems will result. **IT IS IMPOSSIBLE TO OVERSIZE AIR FILTERS.** Generous sizing will result in cleaner air and coils, as well as lower operating costs and extend the time between required changes. The following table shows minimum filter areas and recommended filter sizes. Actual filter sizes can vary with the installation due to single or multiple returns utilizing a filter/grille arrangement or being placed immediately ahead of the indoor coil face in the return air duct.

Model	Minimum Filter Areas	Recommended Size
2, 2½, 3 Ton	462 sq.in. (3.21 sq.ft)	15x30-5/8 x 1
4, 5 Ton	608 sq.in. (4.62 sq.ft)	(2) 16x20 x 1

**NOTE:** If Roof Hood Accessory is to be used, information on air filters may be found under that heading in this manual. Air filters are supplied as part of that package.

## REFRIGERANT CHARGE

The correct system R-22 charge is shown on the unit rating plate. Optimum unit performance will occur with a refrigerant charge resulting in a suction line temperature (6" from compressor) as shown in the following table:

Model	Rated Airflow	55°F O.D. Temp.	82°F O.D. Temp.
2 Ton	800	56 - 58	61 - 63
2½ Ton	1150	52 - 54	62 - 64
3 Ton	1275	51 - 53	59 - 61
4 Ton	1700	52 - 54	61 - 63
5 Ton	1775	53 - 55	63 - 65

The above suction line temperatures are based upon 80°F dry bulb/67° wet bulb (50% R.H.) temperature and rated airflow across the evaporator during cooling cycle.

## CRANKCASE HEATERS

All units are provided with some form of compressor crankcase heat. Some single phase units utilize the compressor motor start winding in series with a portion of the run capacitor to generate heat within the compressor shell to prevent liquid refrigerant migration.

Some single and three phase models have an insertion well-type heater located in the lower section of the compressor housing. This is a self-regulating type heater that draws only enough power to maintain the compressor at a safe temperature.

Some form of crankcase heat is essential to prevent liquid refrigerant from migrating to the compressor, causing oil pump out on compressor start-up and possible valve failure due to compressing a liquid.

Refer to unit wiring diagram to find exact type of crankcase heater used.

The following decal is affixed to all outdoor units detailing start-up procedure. This is very important. Please read carefully.

## IMPORTANT

THESE PROCEDURES MUST BE FOLLOWED AT INITIAL START-UP AND AT ANY TIME POWER HAS BEEN REMOVED FOR 12 HOURS OR LONGER.

TO PREVENT COMPRESSOR DAMAGE WHICH MAY RESULT FROM THE PRESENCE OF LIQUID REFRIGERANT IN THE COMPRESSOR CRANKCASE

1. MAKE CERTAIN THE ROOM THERMOSTAT IS IN THE "OFF" POSITION (THE COMPRESSOR IS NOT TO OPERATE).
2. APPLY POWER BY CLOSING THE SYSTEM DISCONNECT SWITCH. THIS ENERGIZES THE COMPRESSOR HEATER WHICH EVAPORATES THE LIQUID REFRIGERANT IN THE CRANKCASE.
3. ALLOW 4 HOURS OR 60 MINUTES PER POUND OF REFRIGERANT IN THE SYSTEM AS NOTED ON THE UNIT RATING PLATE, WHICHEVER IS GREATER.
4. AFTER PROPERLY ELAPSED TIME THE THERMOSTAT MAY BE SET TO OPERATE THE COMPRESSOR.
5. EXCEPT AS REQUIRED FOR SAFETY WHILE REPAIRING - DO NOT OPEN SYSTEM DISCONNECT SWITCH.

7861-061

## IMPORTANT INSTALLER NOTES

For improved start-up performance wash the indoor coil with a dishwasher detergent.

## OPTIONAL ELECTRIC HEATERS

These packaged air conditioners are manufactured without supplementary electric heaters. Supplementary heaters EH3PA series (to fit 2, 2½ and 3 Ton) and EH5PA series (to fit 4 Ton and 5 Ton) are available for simple, fast field installation.

A separate field power circuit is required for the supplementary heaters.

Refer to the electrical data shown on page 1 for proper application information on all available heater combinations and what units they can be used with. It also shows the applicable circuit capacities, fuse size and wire size for each heater combination.

Refer to the installation instructions packed with the heater for details on how to insert it into the basic unit.

If this unit is operated in cooling below a 65° outdoor ambient temperature, the installation of low ambient control (LAC-1) to unit is required.

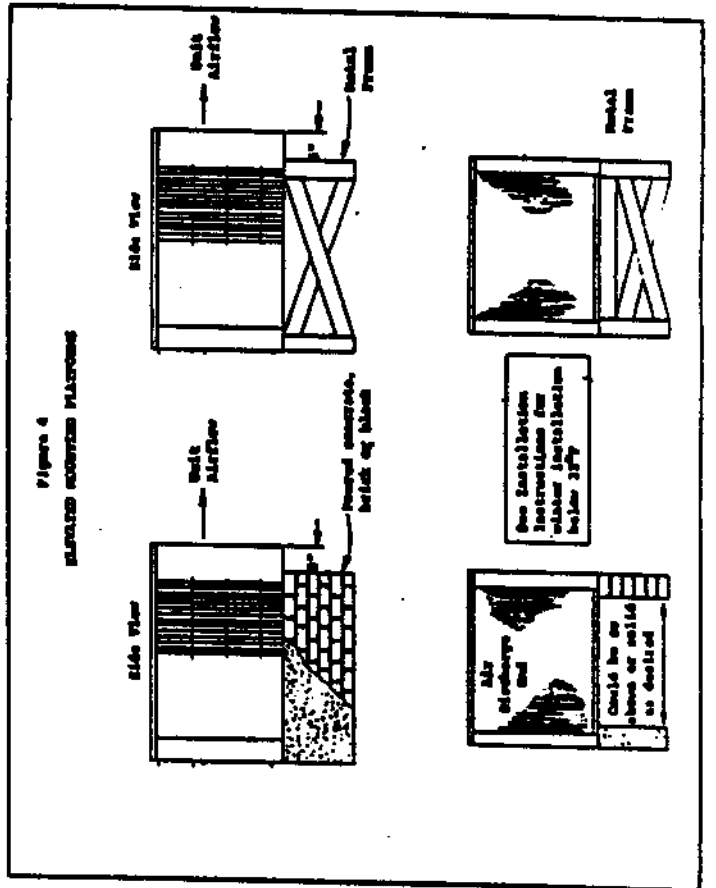
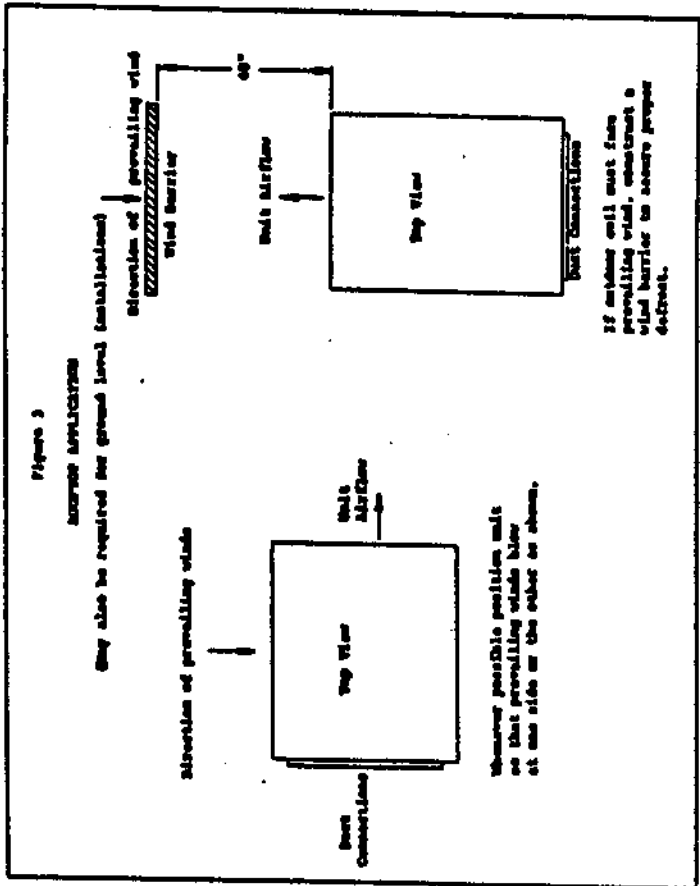
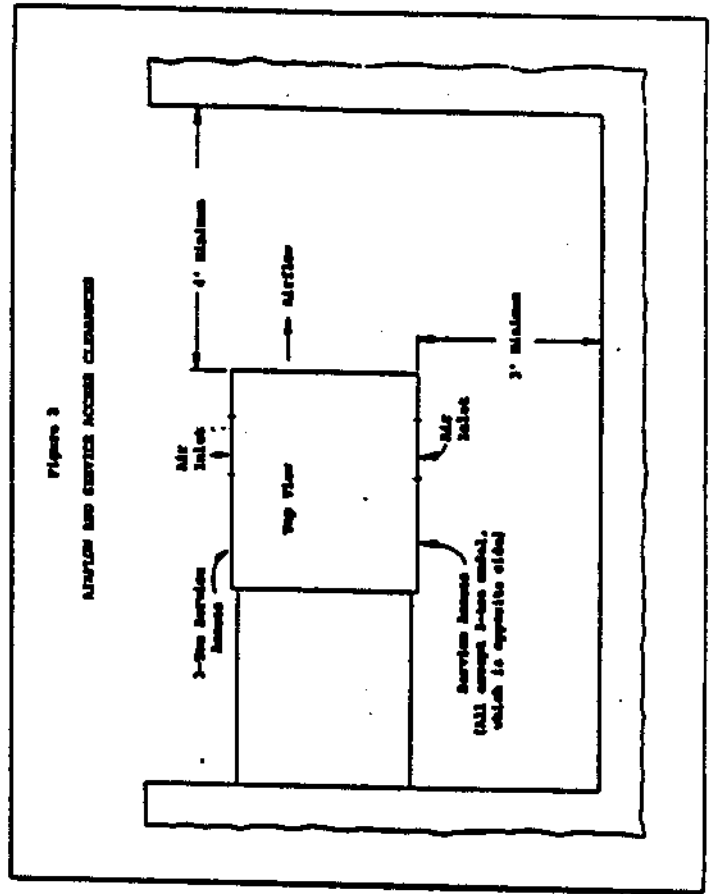
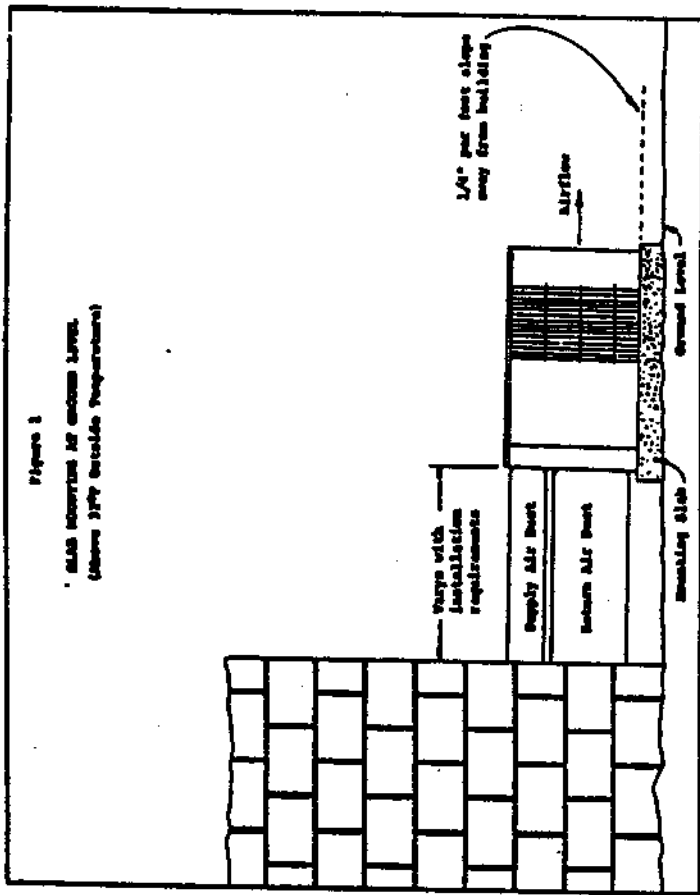

# PACKAGED AIR CONDITIONER MODEL 2 Ton

These curves are based upon 80°DB, 67°WB R.A. Temp. and rated CFM (airflow) across the evaporator coil and should be used for reference purposes only. Special information can be found under section titled "Refrigerant Charge" elsewhere in manual. If there is any doubt as to correct operating charge being in the system, the charge should be removed, system evacuated, and recharged according to serial plate instructions.

HIGH SIDE (DISCHARGE LINE) PRESSURE--PSIG

LOW SIDE PRESSURE--PSIG  
(SUCTION LINE)

AIR TEMPERATURE ENTERING OUTDOOR COIL--DEGREE F.

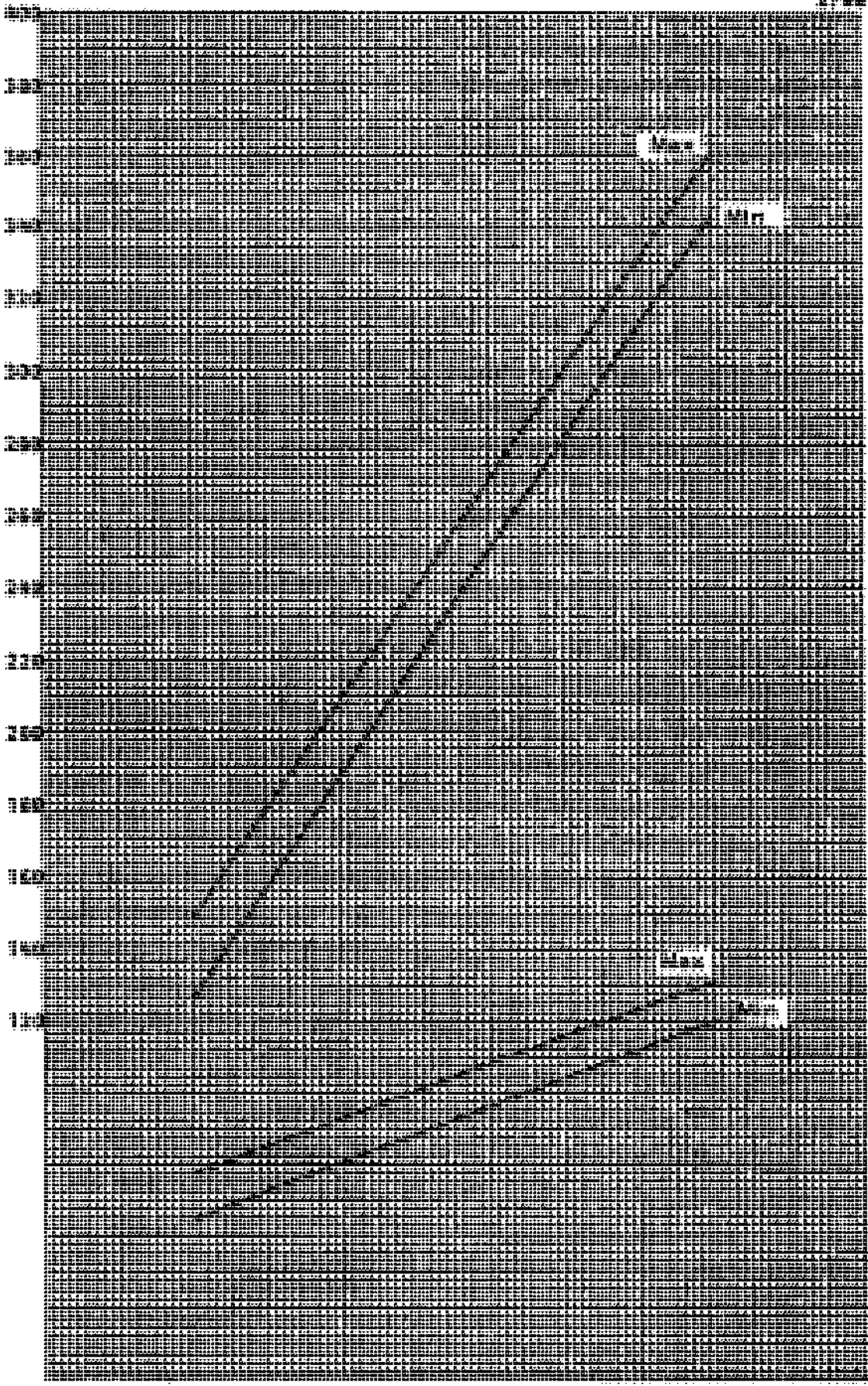

# PACKAGED AIR CONDITIONER MODEL 24 Ton

These curves are based upon 80°DB, 67°WB R.A. Temp. and Rated CFM (airflow) across the evaporator coil and should be used for reference purposes only. Special information can be found under section titled "Refrigerant Charge" elsewhere in manual. If there is any doubt as to correct operating charge being in the system, the charge should be removed, system evacuated, and recharged according to serial plate instructions.

HIGH SIDE (DISCHARGE LINE) PRESSURE--PSIG

LOW SIDE PRESSURE--PSIG  
(SUCTION LINE)

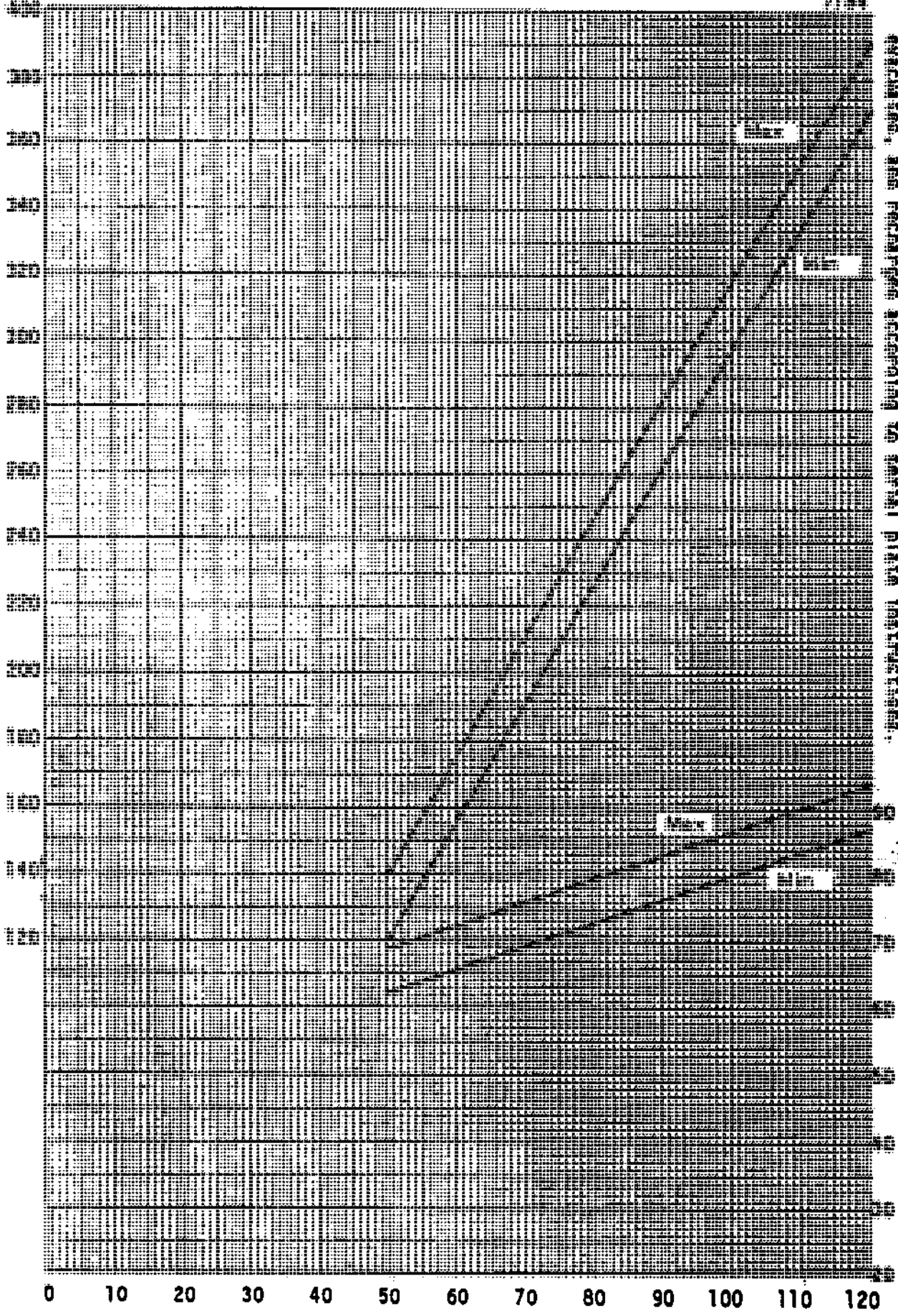

AIR TEMPERATURE ENTERING OUTDOOR COIL--DEGREE F.

PACKAGED AIR CONDITIONER MODEL 3 Ton

7114

These curves are based upon 80°DB, 67°WB R.A. Temp. and Rated CFM (airflow) across the evaporator coil and should be used for reference purposes only. Special information can be found under section titled "Refrigerant Charge" elsewhere in manual. If there is any doubt as to correct operating charge being in the system, the charge should be removed, system evacuated, and recharged according to serial plate instructions.

HIGH SIDE (DISCHARGE LINE) PRESSURE--PSIG

LOW SIDE PRESSURE--PSIG  
(SUCTION LINE)

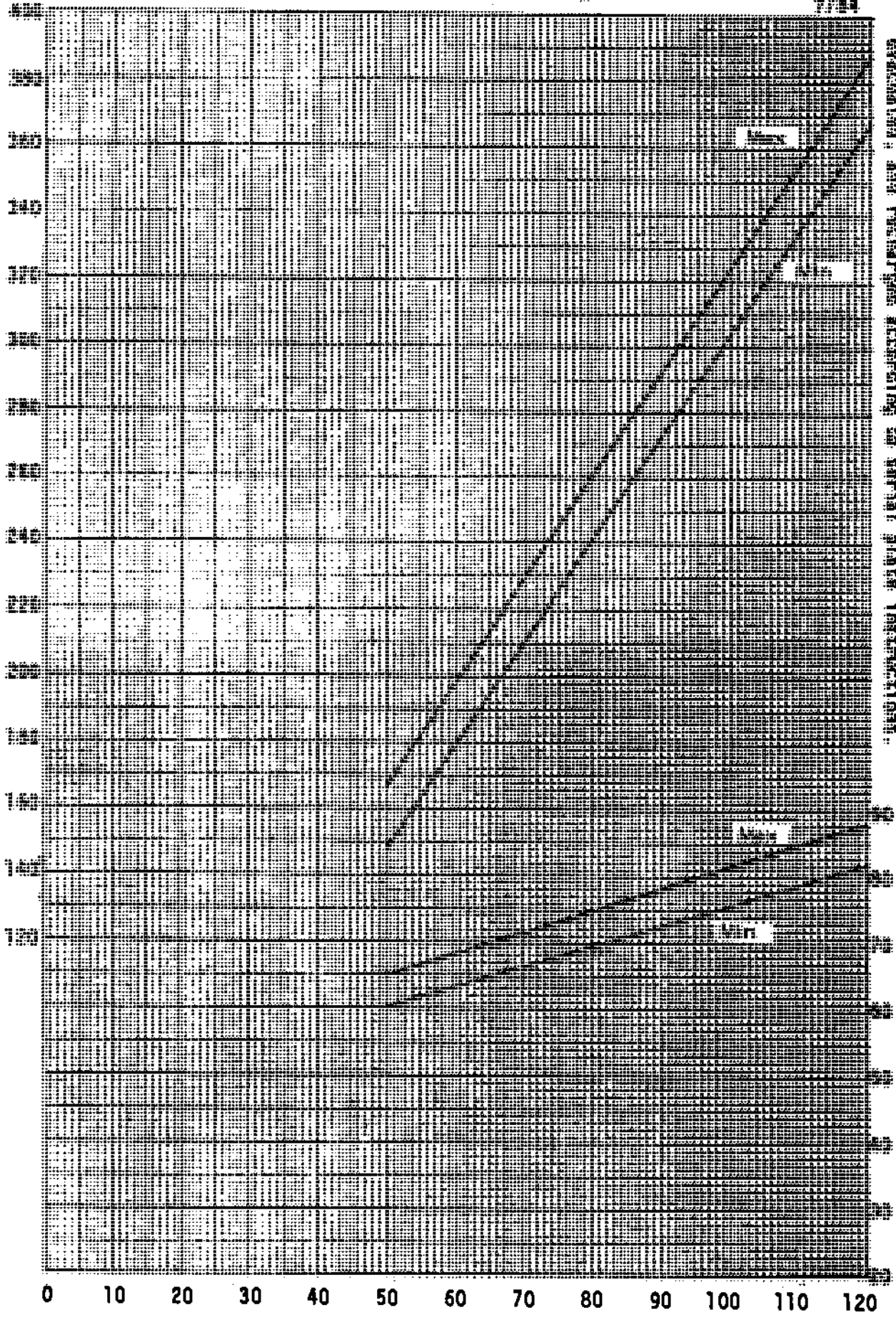

AIR TEMPERATURE ENTERING OUTDOOR COIL--DEGREE F.



PACKAGED AIR CONDITIONER MODEL 1 Ton

These curves are based upon 80°DB, 67°WB R.A. Temp. and Rated CFM (airflow) across the evaporator coil and should be used for reference purposes only. Special information can be found under section titled "Refrigerant Charge" elsewhere in manual. If there is any doubt as to correct operating charge being in the system, the charge should be removed, system evacuated, and recharged according to serial plate instructions.

LOW SIDE PRESSURE--PSIG  
(SUCTION LINE)

HIGH SIDE (DISCHARGE LINE) PRESSURE--PSIG

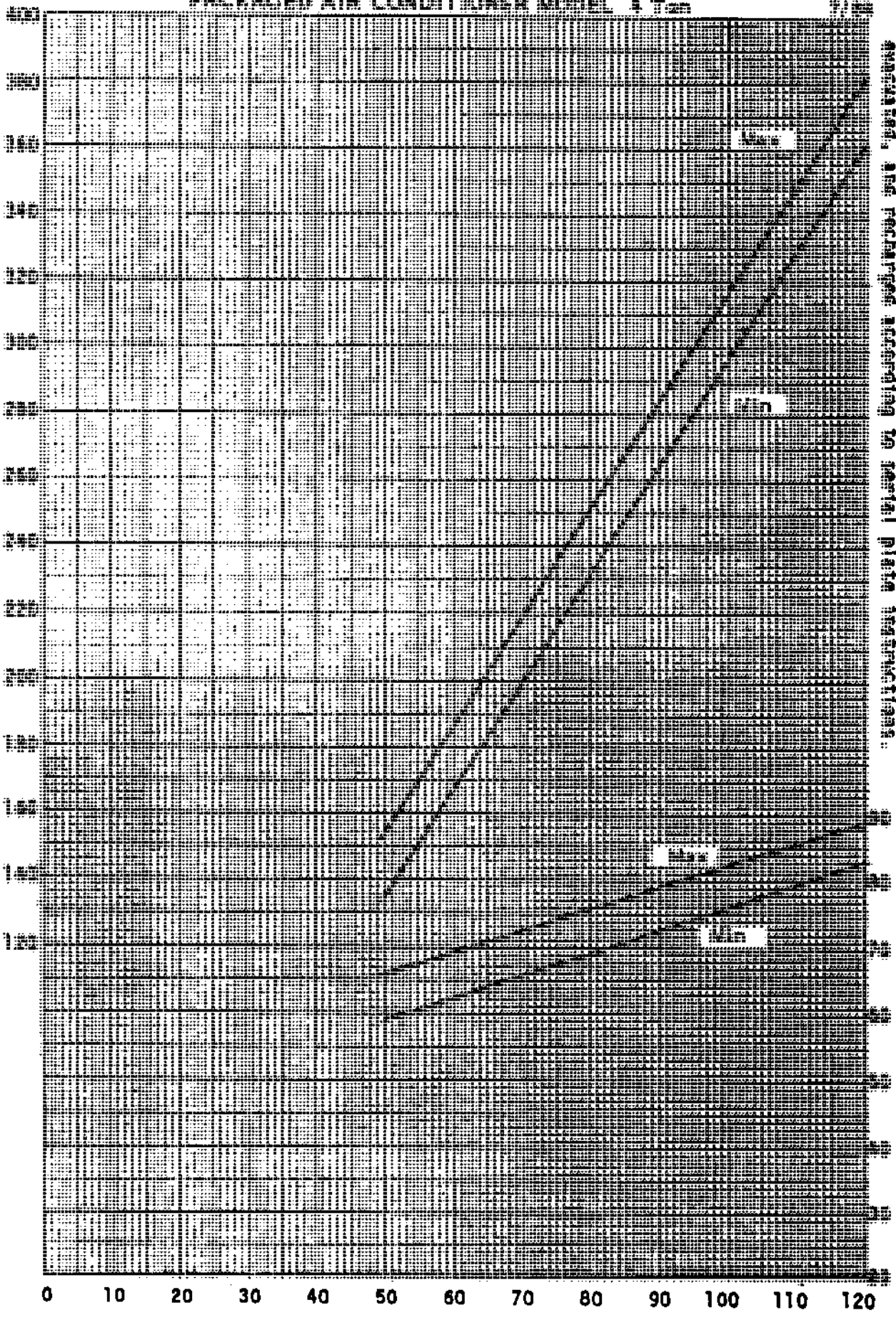

AIR TEMPERATURE ENTERING OUTDOOR COIL--DEGREE F.

These curves are based upon 80°DB, 67°WB R.A. Temp. and rated CFM (airflow) across the evaporator coil and should be used for reference purposes only. Special information can be found under section titled "Refrigerant Charge" elsewhere in manual. If there is any doubt as to correct operating charge being in the system, the charge should be removed, system evacuated, and recharged according to serial plate instructions.

HIGH SIDE (DISCHARGE LINE) PRESSURE--PSIG

LOW SIDE PRESSURE--PSIG  
(SUCTION LINE)

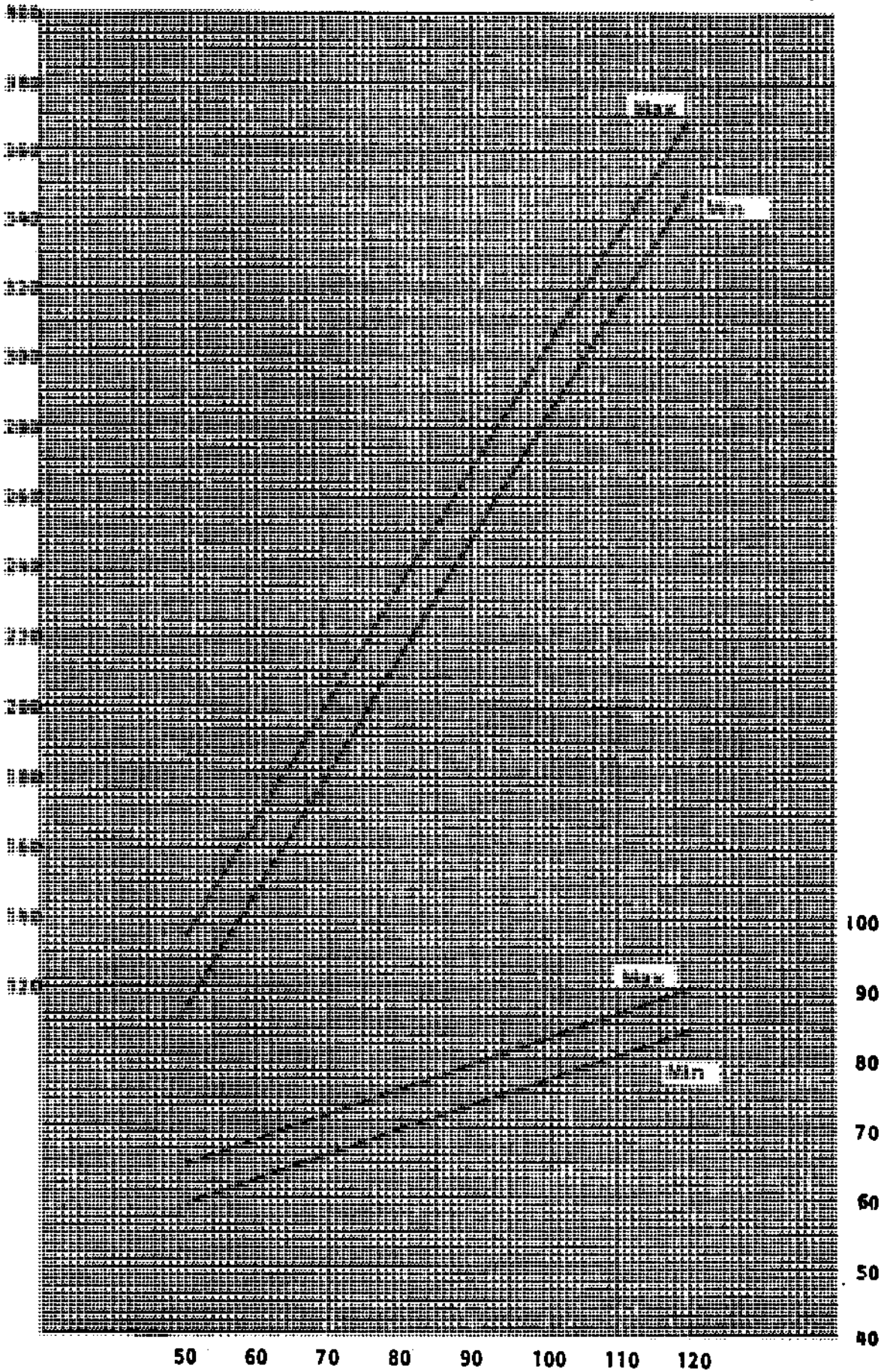

AIR TEMPERATURE ENTERING OUTDOOR COIL--DEGREE F.

**PARTS LIST**  
**SINGLE PACKAGE AIR CONDITIONERS**

2/86

PART NO.	DESCRIPTION	2 Ton	2½ Ton	2½ Ton 460V	3 Ton	3 Ton 3-Ph	3 Ton 460V 3-Ph
*	Blower Housing	x	x	x	x	x	x
5152-008	Blower Wheel DD10-4A	x					
5152-010	Blower Wheel DD10-7A		x	x			
5152-013	Blower Wheel DD10-8A				x	x	x
8552-032	Capacitor - Comp. 35/370V	x					
8552-007	Capacitor - Comp. 20/15-370V		x				
8552-035	Capacitor - Comp. 40/370V				x		
8552-002	Capacitor - Fan & Blower 5/370V	x	x	x	x	x	x
5811-009	Capillary Tube - Cool	(2)					
5811-014	Capillary Tube - Cool		(2)	(2)			
5811-033	Capillary Tube - Cool				(2)	(2)	(2)
8000-090	Compressor - H22B233ABCA	x					
8000-070	Compressor - AB233HT		x				
8000-054	Compressor - CRG3-0250-TFD			x			
8000-055	Compressor - CRH3-0275-PFV				x		
8000-056	Compressor - CRH3-0275-TF5					x	
8000-057	Compressor - CRH3-0275-TFD						x
5051-034	Condenser Coil	x					
5051-035	Condenser Coil		x	x	x	x	x
8401-007	Contactora - Comp. 1P25A	x	x		x		
8401-002	Contactora - Comp. 3P25A			x		x	x
5060-037	Evaporator Coil	x	x	x	x	x	x
5151-034	Fan Blade BT2026-2	x					
5151-004	Fan Blade TP2026		x	x	x	x	x
8105-027	Motor - Blower 1/3 hp ccw	x					
8105-024	Motor - Blower 1/3 hp ccw		x		x	x	
8103-016	Motor - Fan 1/5 hp cw	x					
8103-009	Motor - Fan 1/5 hp cw				x	x	
8105-016	Motor - Blower 1/3 hp ccw			x			x
8103-014	Motor - Fan 1/5 hp cw			x			x
8200-003	Motor Mount - Blower	x	x	x	x	x	x
8200-001	Motor Mount - Fan	x	x	x	x	x	x
5451-011	Motor Mounting Parts	x	x	x	x	x	x
7051-015	Wire Grille - Inlet	(2)	(2)	(2)	(2)	(2)	(2)
7051-001	Condenser Grille	x	x	x	x	x	x
8201-008	Relay - Blower	x	x	x	x	x	x
5210-004	Strainer	x	x	x	x	x	x
8607-006	Terminal Board 24V	x	x	x	x	x	x
8607-013	Terminal Block	x	x		x		
8607-014	Terminal Block			x		x	x
8607-015	Phenolic Insulator			x			x
8407-034	Transformer 40VA	x	x		x	x	
8407-027	Transformer 48VA			x			x

\*Please order by model number.  
Minimum net billing \$15.00. Supersedes all previous lists.  
Subject to change without notice.

**PARTS LIST**  
**SINGLE PACKAGE AIR CONDITIONERS**

11/85

Part No.	Description	4 Ton	4 Ton 3-Ph	5 Ton	5 Ton 3-Ph	4 Ton 3 Ph 460V	5 Ton 3 Ph 460 V
*	Blower Housing 10-10	x	x	x	x	x	x
5152-015	Blower Wheel DD10-10A	x	x	x	x	x	x
8552-030	Capacitor 40/440V	x					
8552-005	Capacitor 10/370V	x	x	x	x	x	x
8552-026	Capacitor 15/370V	x	x			x	
8552-031	Capacitor 45/440V			x			
8552-004	Capacitor 7½/370V			x	x		x
5811-033	Capillary Tube - Cool	(3)	(3)			(3)	
5811-032	Capillary Tube - Cool			(2)	(2)		(2)
8000-081	Compressor AV168ET	x					
8000-082	Compressor AV169RT		x				
8000-083	Compressor AV169TT					x	
8000-091	Comp. 703006-18-0733			x			
8000-031	Compressor AG122RT				x		
8000-048	Compressor AG122UT						x
5051-027	Condenser Coil	x	x			x	
5051-028	Condenser Coil			x	x		x
8401-007	Contactator 1P25A	x					
8401-002	Contactator 3P25A		x			x	x
8401-016	Contactator 1P35A			x			
8401-011	Contactator 3P30A				x		
5060-036	Evaporator Coil	x	x			x	
5151-029	Fan Blade T10H08-2436	x	x			x	
5151-030	Fan Blade T10H08-2428			x	x		x
7051-007	Wire Grille - Inlet	(2)	(2)	(2)	(2)	(2)	(2)
7051-005	Condenser Grille	x	x	x	x	x	x
8106-015	Motor - Blower 1/2 hp	x	x	x	x	x	x
8105-021	Motor - Fan 1/3 hp	x	x			x	
8106-016	Motor - Fan 1/2 hp			x	x		x
5451-011	Motor Mounting Parts	x	x	x	x	x	x
8200-004	Motor Mount - Fan	x	x	x	x	x	x
8200-028	Motor Mount - Blower	x	x	x	x	x	x
8201-008	Relay - Blower	x	x	x	x	(2)	(2)
5210-009	Strainer	x	x			x	
5210-005	Strainer			x	x		x
8607-006	Terminal Board 24V	x	x	x	x	x	x
8607-013	Terminal Block	x		x			
8607-014	Terminal Block		x		x	x	x
8407-034	Transformer 40VA	x	x	x	x	x	x
8407-004	Stepdown Transformer					x	x
5060-039	Evaporator Coil			x	x		x
8607-017	Terminal Block					x	x

Minimum Net Billing \$15.00. Supersedes all previous lists.  
Subject to change without notice.

\*Please order by model number.

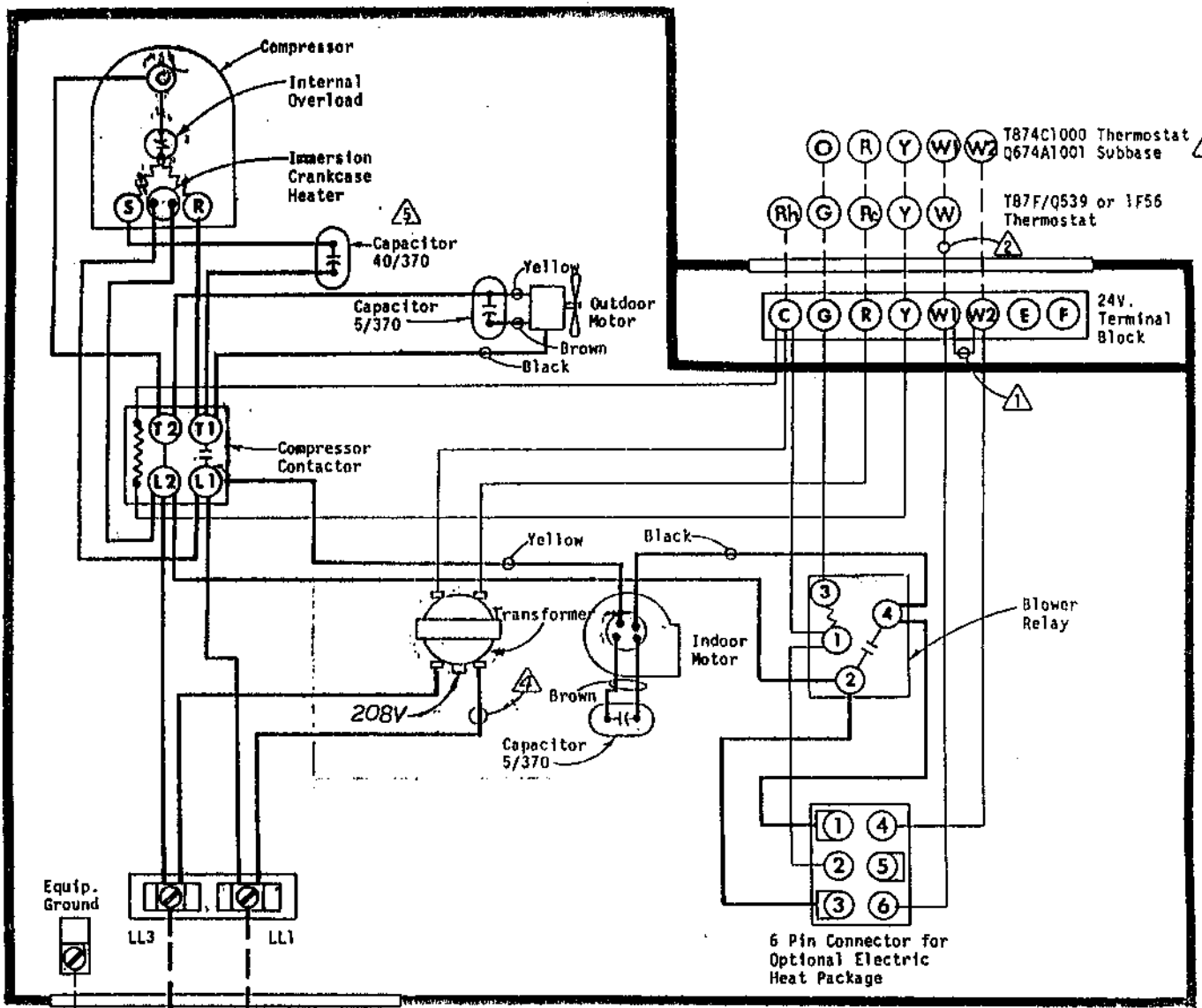

- ⚠ Remove jumper for two stage heat
- ⚠ Not required when Optional Heat Packages are not installed
- ⚠ Required only for use with Optional Electric Heat Packages: EH3PA-1-15A, EH3PA-3-12B, EH3PA-3-15B. When two stage heat is desired.
- ⚠ For 208V operation move this wire to 208V transformer tap.
- ⚠ Compressor Run Capacitor is located on the back of the Blower Partition

230/208V 60Hz 1-Ph

MODEL  
3 TON

USE COPPER OR ALUMINUM WIRE

FACTORY WIRING	FIELD WIRING
Low Voltage	
High Voltage	

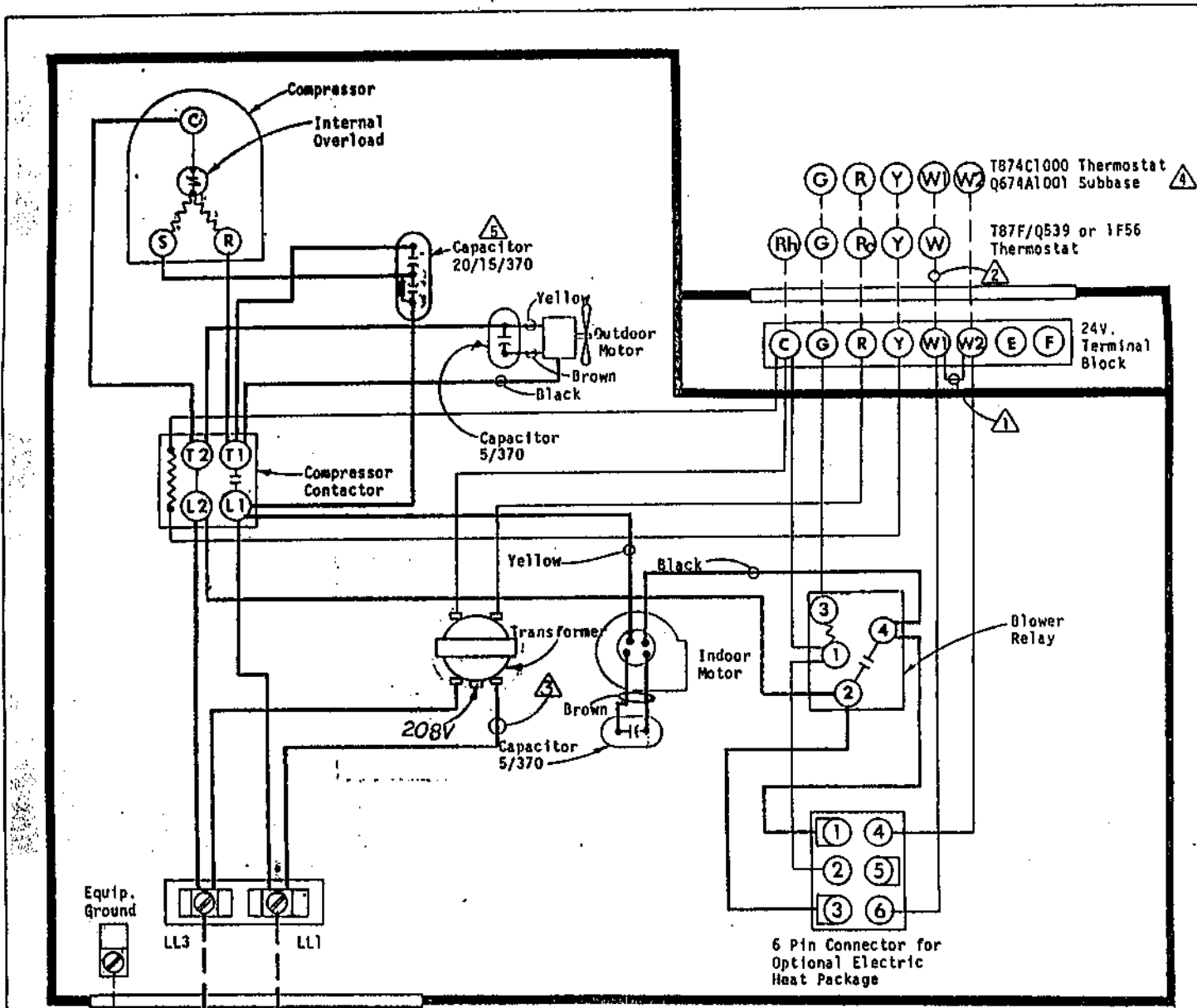

- ⚠ Remove jumper for two stage heat
- ⚠ Not required when Optional Heat Packages are not installed
- ⚠ For 208V operation move this wire to 208V transformer tap.
- ⚠ Required only for use with Optional Electric Heat Packages: EH3PA-1-15A, EH3PA-3-12B, EH3PA-3-15B. When two stage heat is desired.
- ⚠ Compressor Run Capacitor is located on back of the Blower Partition, Capacitor provides off-cycle crackcase heat.

230/208V 60Hz 1-Pb

USE COPPER OR ALUMINUM WIRE

MODEL  
2 1/2 TON

FACTORY WIRING	FIELD WIRING
Low Voltage	-----
High Voltage	-----

4063-113

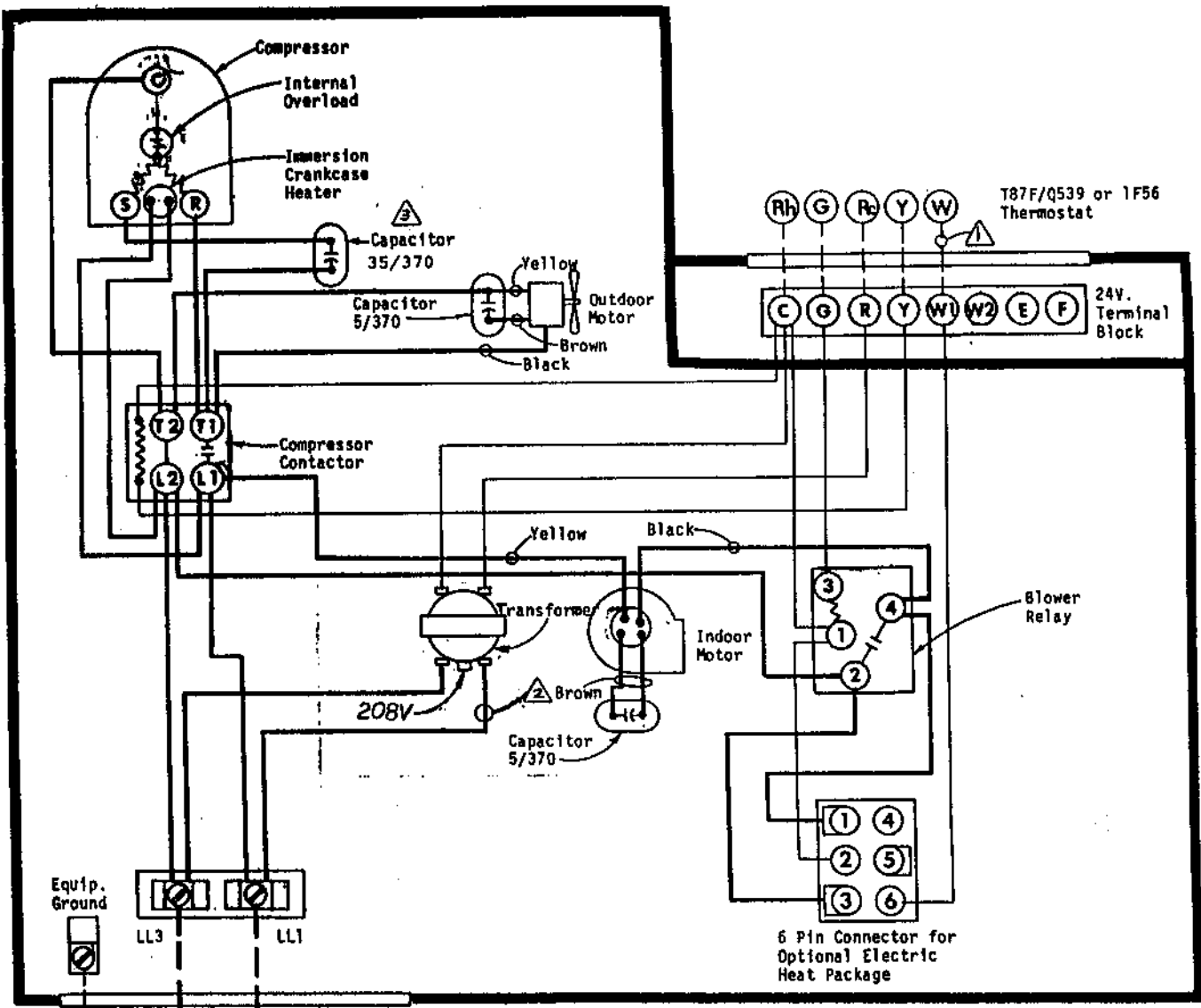

Equip. Ground

LL3

LL1

208V

⚠ Not required when Optional Heat Packages are not installed

② For 208V operation move this wire to 208V transformer tap.

⚠ Compressor Run Capacitor is located on the back of the Blower Partition

Fused Disconnect Switch

230/208V 60Hz 1-Ph

USE COPPER OR ALUMINUM WIRE

MODEL  
2 TON

FACTORY WIRING	FIELD WIRING
Low Voltage	-----
High Voltage	-----

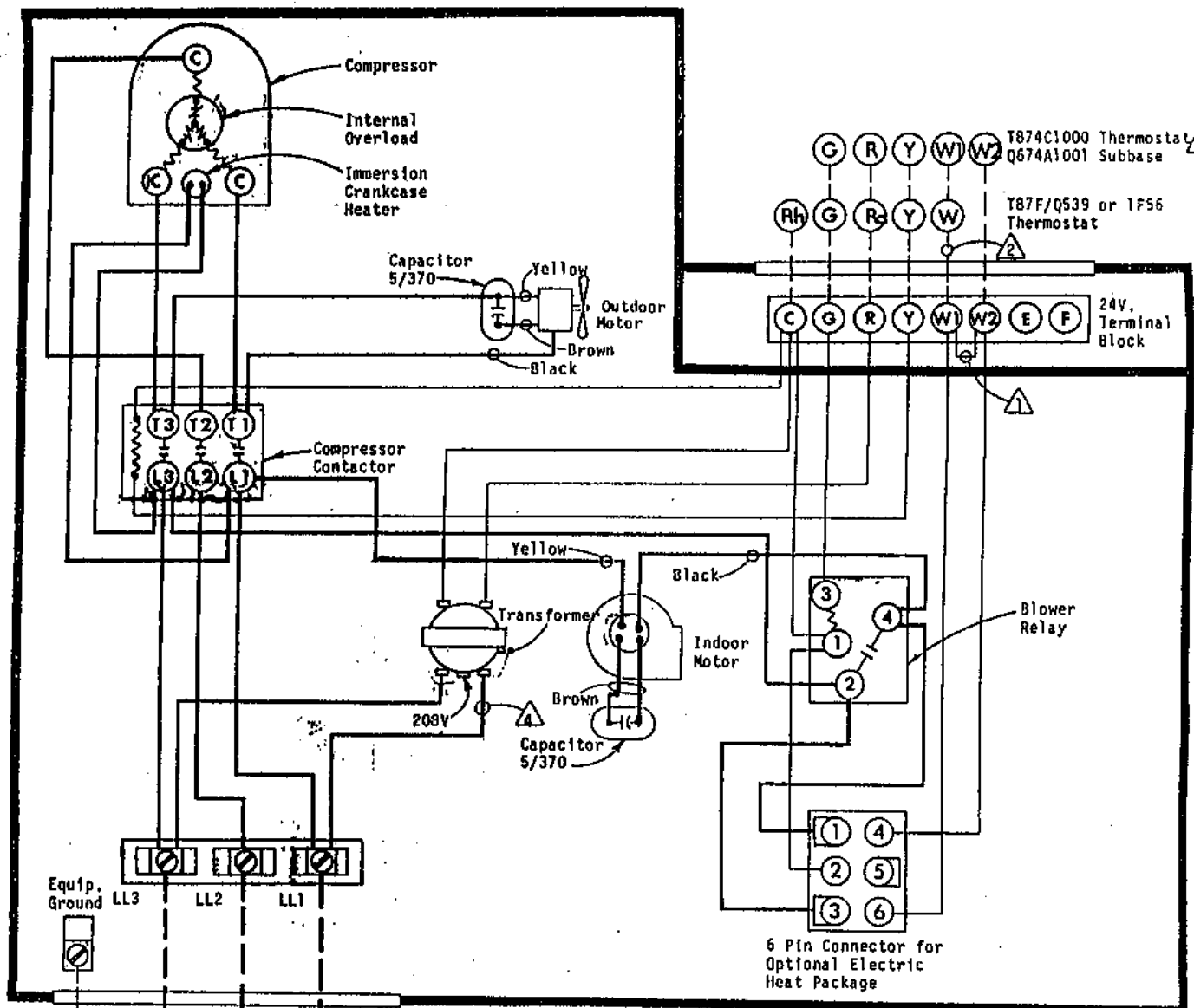

- ⚠ Remove Jumper for two stage heat
- ⚠ Not required when Optional Heat Packages are not installed
- ⚠ Required only for use with Optional Electric Heat Packages: EH3PA-1-15A, EH3PA-3-12B, EH3PA-3-15B. When two stage heat is desired.
- ⚠ For 208V operation move this wire to 208V transformer tap.

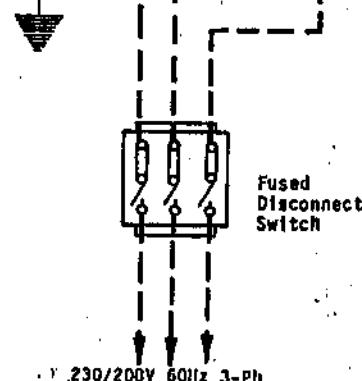

USE COPPER OR ALUMINUM WIRE

MODEL  
3 TON  
3 PH.

FACTORY WIRING	FIELD WIRING
Low Voltage ———	-----
High Voltage ———	-----



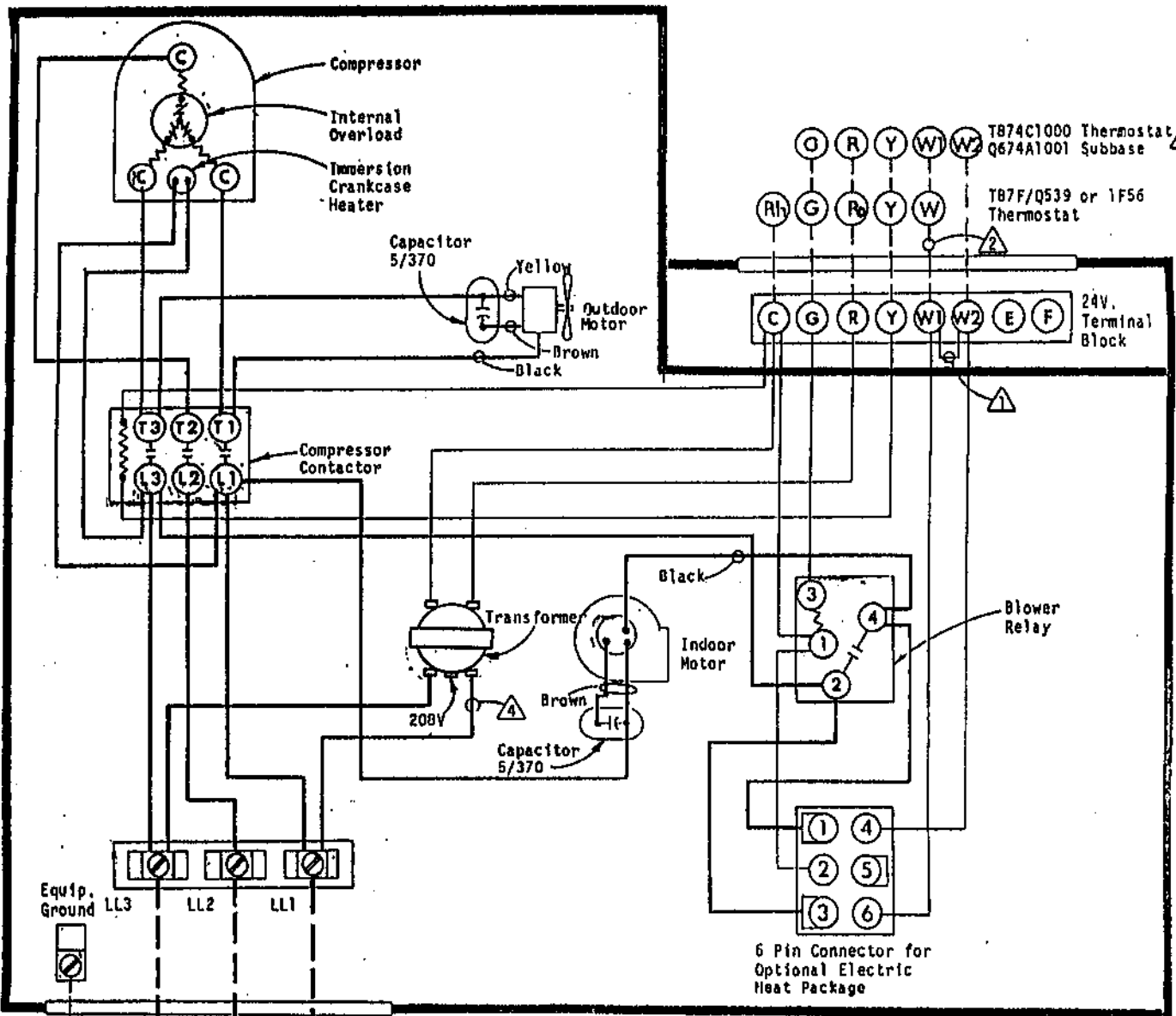

Equip. Ground

LL3 LL2 LL1

450V 60Hz 3-Ph

Fused Disconnect Switch

- ⚠ Remove jumper for two stage heat
- ⚠ Not required when Optional Heat Packages are not installed
- ⚠ Required only for use with Optional Electric Heat Packages: EH3PA-1-15A, EH3PA-3-12B, EH3PA-3-15B. When two stage heat is desired.
- ⚠ For 208V operation move this wire to 208V transformer tap.

USE COPPER OR ALUMINUM WIRE

FACTORY WIRING	FIELD WIRING
Low Voltage	-----
High Voltage	-----

MODELS  
2 1/2 ton  
3 ton  
3 PH

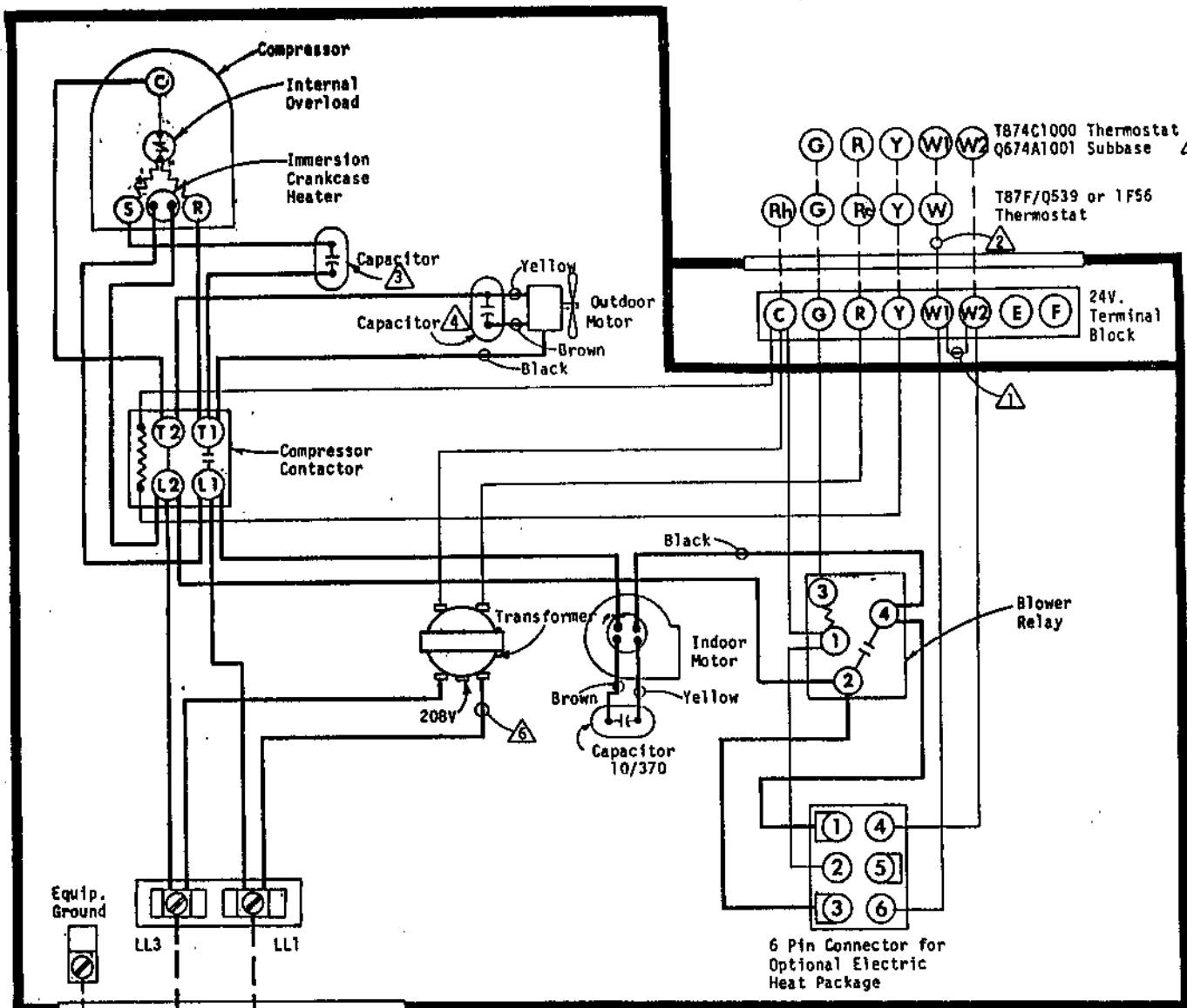

Equip. Ground

LL3

LL1

230/208V 60Hz 1-Ph

Fused Disconnect Switch

- ⚠ Remove jumper for two stage heat
- ⚠ Not required when Optional Heat Packages are not installed
- ⚠ P48A5 - 40/440V  
P60A6 - 45/440V
- ⚠ P48A5 - 15/370V  
P60A6 - 7-1/2/370V
- ⚠ Required only for use with Optional Electric Heat Packages: EH5PA-1-5A, EH5PA-1-10A, EH5PA-1-15A, EH5PA-1-20A, EH5PA-3-9B, EH5PA-3-12B, EH5PA-3-15B, EH5PA-3-18B.
- ⚠ For 208V operation move this wire to 208V transformer tap.

MODELS  
4 TON  
5 TON

USE COPPER OR ALUMINUM WIRE

FACTORY WIRING	FIELD WIRING
Low Voltage ———	-----
High Voltage ———	-----

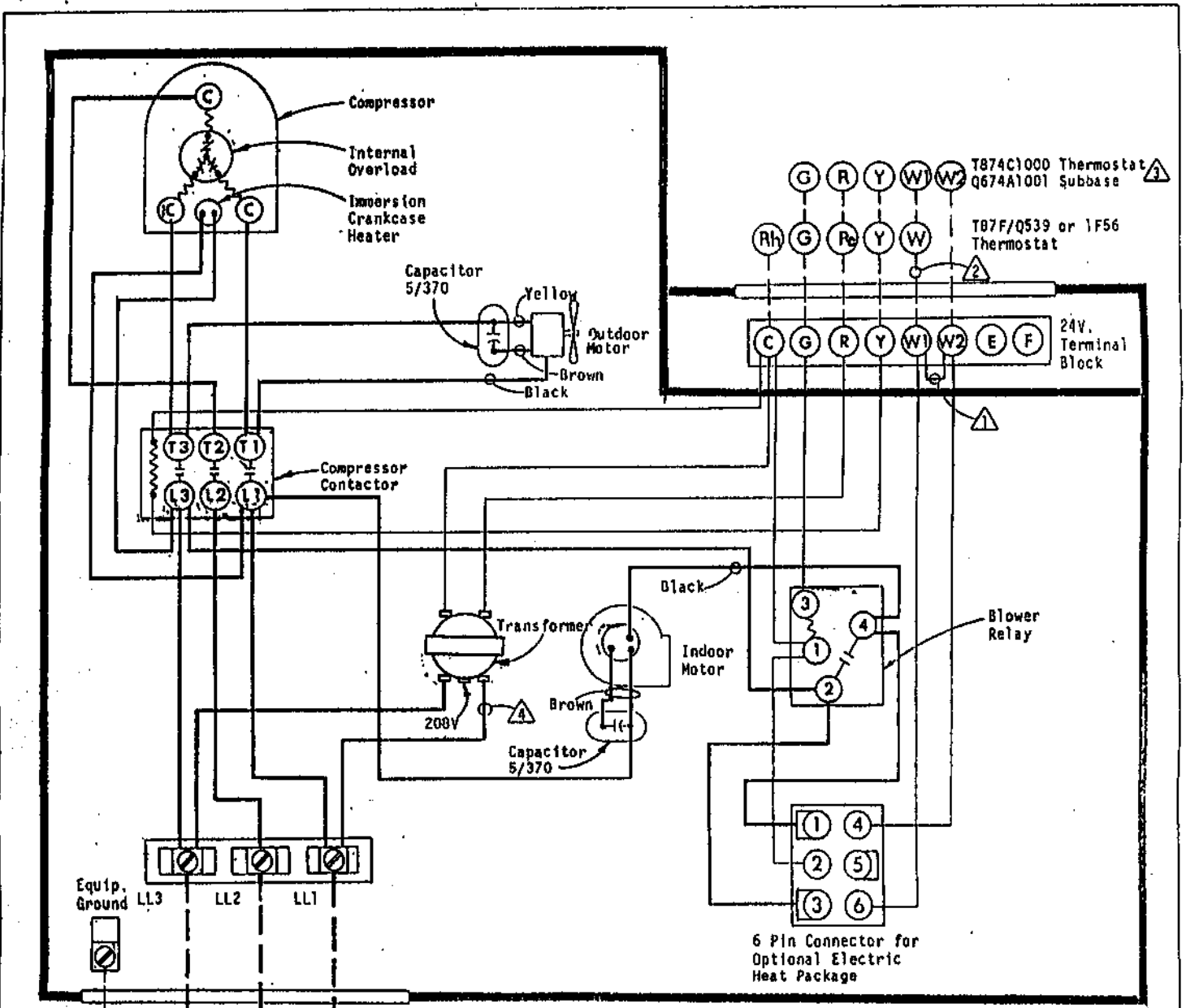

- ⚠ Remove jumper for two stage heat
- ⚠ Not required when Optional Heat Packages are not installed
- ⚠ Required only for use with Optional Electric Heat Packages: BH3PA-1-15A, BH3PA-3-12B, BH3PA-3-15B. When two stage heat is desired.
- ⚠ For 208V operation move this wire to 208V transformer tap.

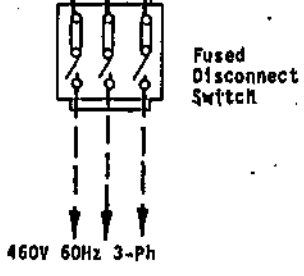

USE COPPER OR ALUMINUM WIRE

MODELS  
2 1/2 ton  
3 ton  
3 PH

FACTORY WIRING	FIELD WIRING
Low Voltage	-----
High Voltage	-----

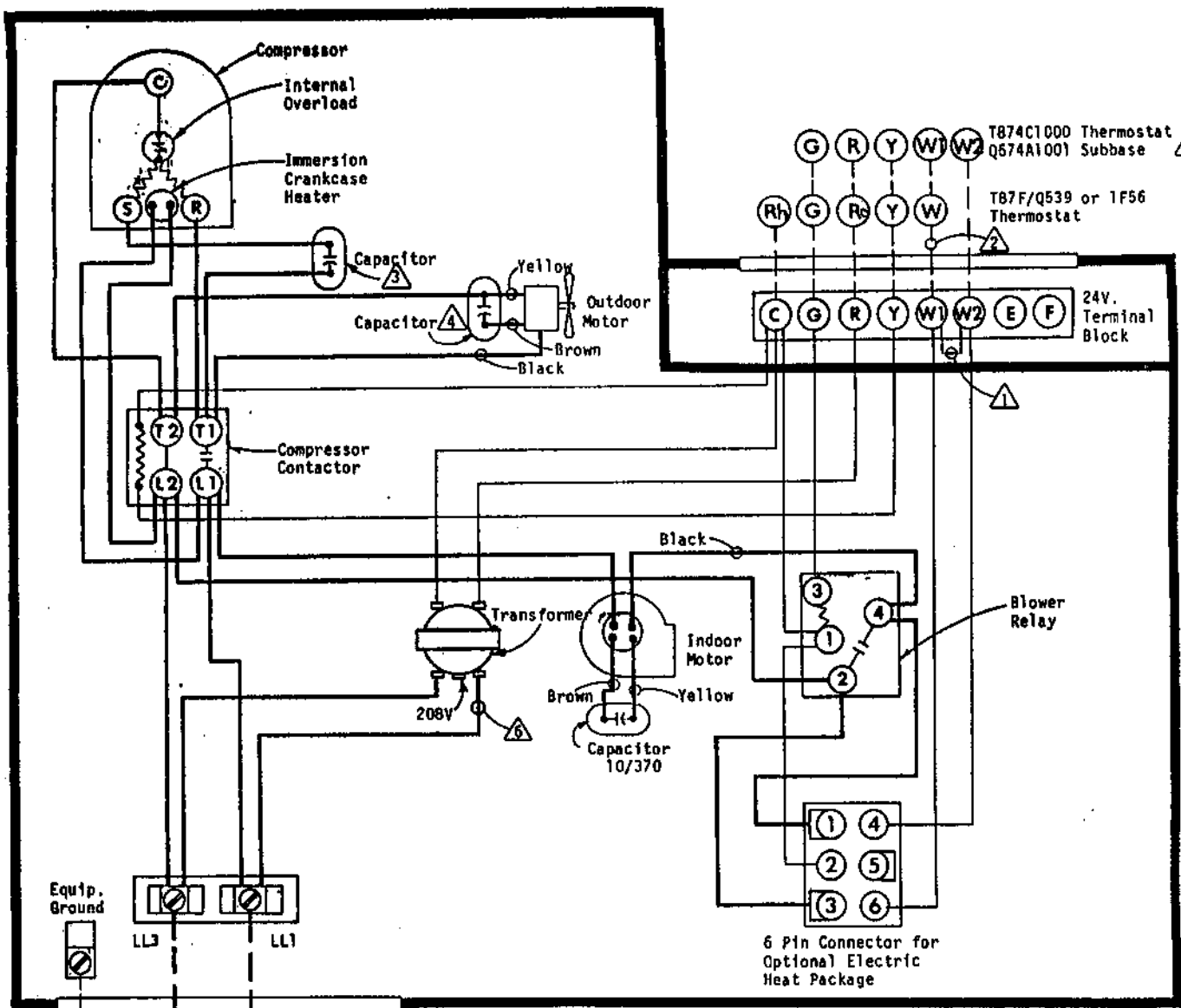

Equip. Ground



230/208V 60Hz 1-ph

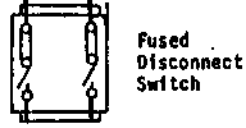

- ⚠ Remove jumper for two stage heat
- ⚠ Not required when Optional Heat Packages are not installed
- ⚠ P48A5 - 40/440V  
P60A6 - 45/440V
- ⚠ P48A5 - 15/370V  
P60A6 - 7-1/2/370V
- ⚠ Required only for use with Optional Electric Heat Packages: EH5PA-1-5A, EH5PA-1-10A, EH5PA-1-15A, EH5PA-1-20A, EH5PA-3-9B, EH5PA-3-12B, EH5PA-3-15B, EH5PA-3-18B.
- ⚠ For 208V operation move this wire to 208V transformer tap.

MODELS  
4 TON  
5 TON

USE COPPER OR ALUMINUM WIRE

FACTORY WIRING      FIELD WIRING

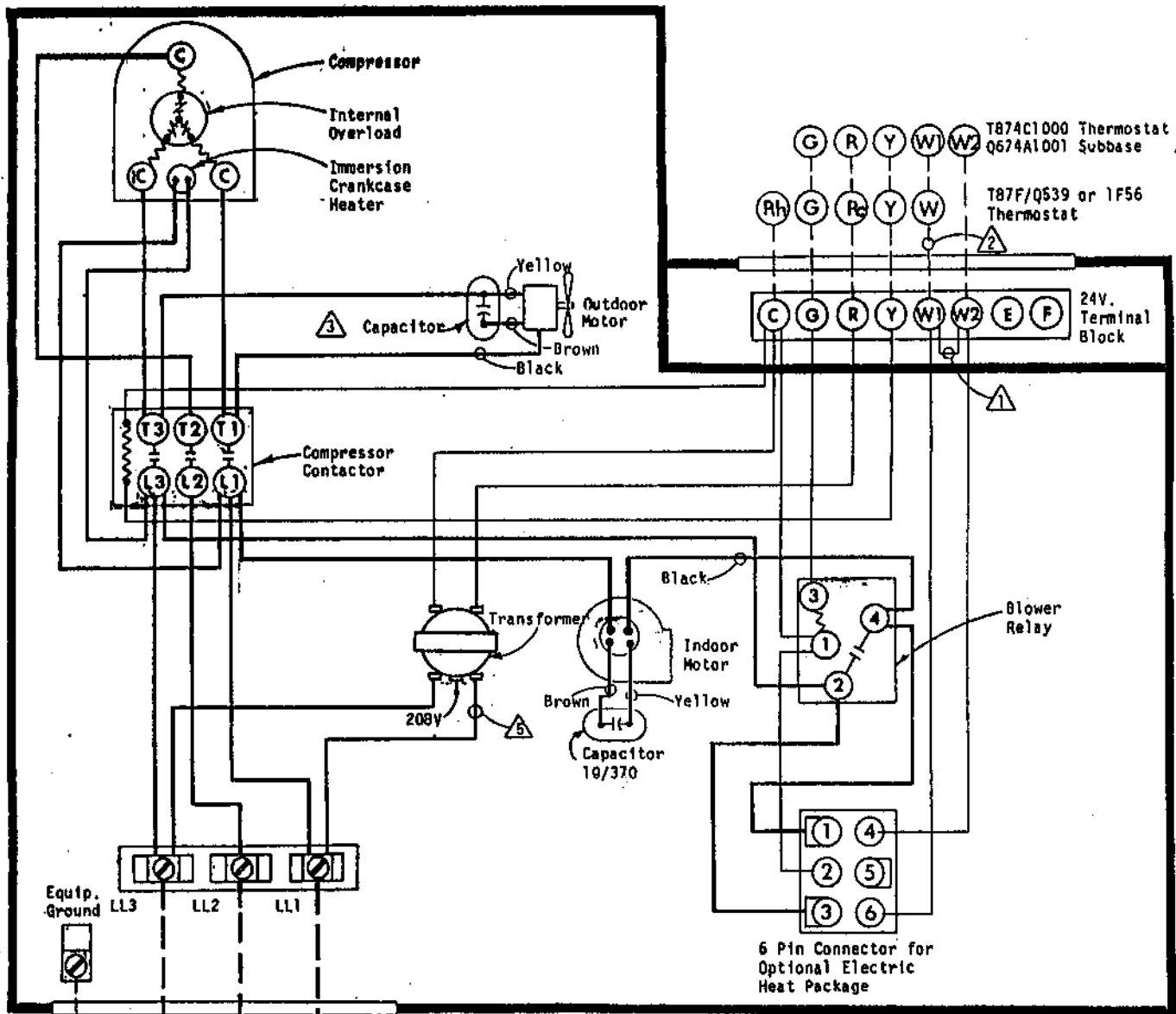

- ⚠ Remove jumper for two stage heat
- ⚠ Not required when Optional Heat Packages are not installed
- ⚠ P48A5 - 15/370  
P60A6 - 7-1/2 / 370
- ⚠ Required only for use with Optional Electric Heater Package: EH5PA-1-5A, EH5PA-1-10A, EH5PA-1-15A, EH5PA-1-20A, EH5PA-3-9B, EH5PA-3-12B, EH5PA-3-15B, EH5PA-3-18B.
- ⚠ For 208V operation move this wire to 208V transformer tap.

230/208V 60 Hz 3-Ph

**USE COPPER OR ALUMINUM WIRE**

**MODELS**  
4 TON  
5 Ton  
3 PH.

FACTORY WIRING	FIELD WIRING
Low Voltage	-----
High Voltage	-----

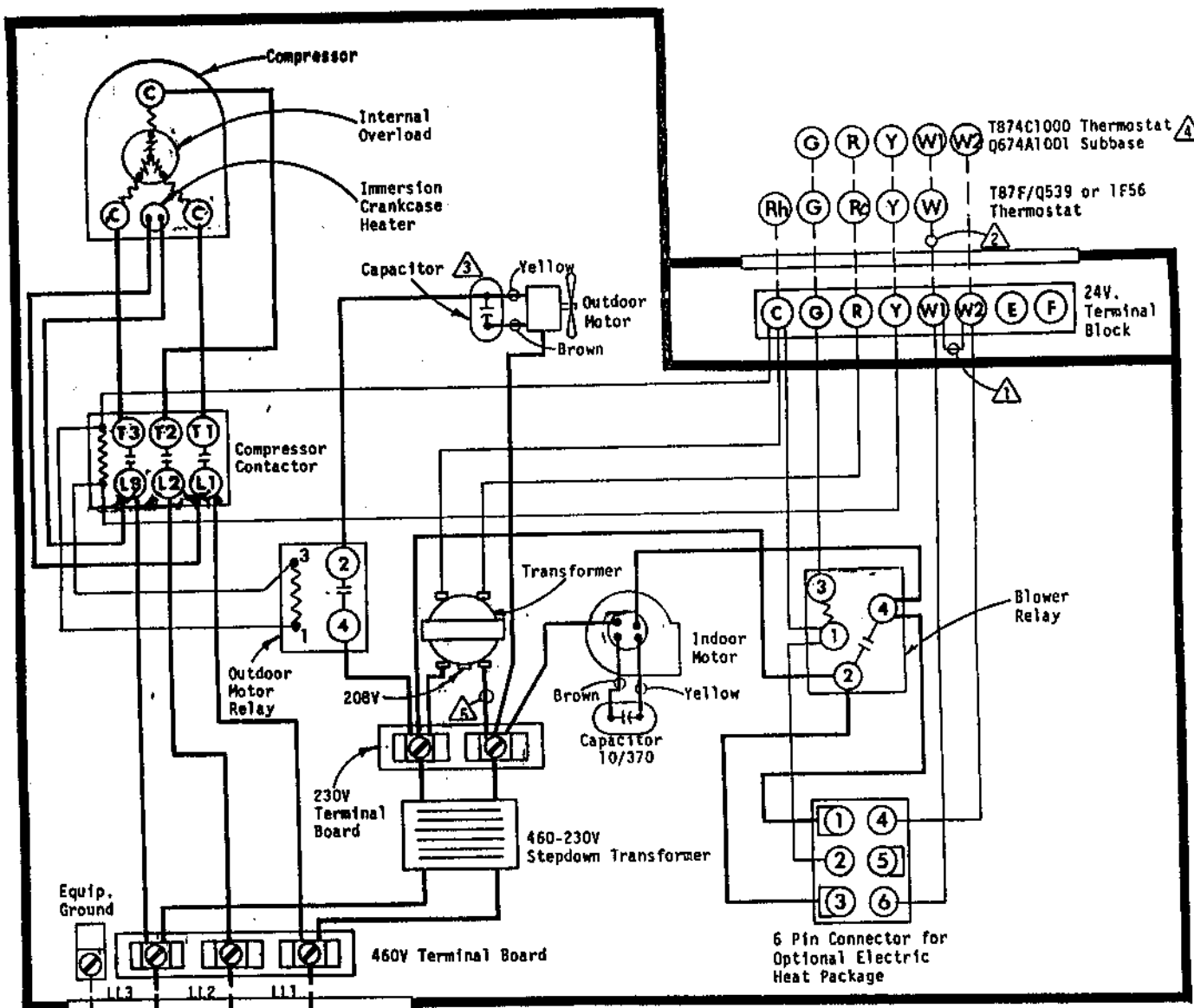

Equip. Ground

L13 L12 L11

460V 60Hz 3-PH

- ⚠ Remove jumper for two stage heat
- ⚠ Not required when Optional Heat Packages are not installed
- ⚠ P48A5 - 15/370  
P60A6 - 7-1/2/370
- ⚠ Required only for use with Optional Electric Heater Packages: EH5PA-1-5A, EH5PA-1-10A, EH5PA-1-15A, EH5PA-1-20A, EH5PA-3-9B, EH5PA-3-12B, EH5PA-3-15B, EH5PA-3-18B, EH5PA-3-9C, EH5PA-3-12C, EH5PA-3-15C, EH5PA-3-18C.
- ⚠ For 208V operation move this wire to 208V transformer tap.



**USE COPPER OR ALUMINUM WIRE**

MODELS
4 TON
5 TON
3 PH.

FACTORY WIRING	FIELD WIRING
Low Voltage	-----
High Voltage	-----