

SPLIT SYSTEM AIR CONDITIONERS

Evaporator Installation Instructions

GENERAL

The model A18AQ&S-A through A60AQ&S-A series indoor cooling coils are designed for use with the 24 through 60UAC series high efficiency outdoor section air conditioners. They are designed for use with gas, oil or electric furnaces. Optional coil casing plenums are also available.

These instructions cover the indoor coil sections listed below, all of which are supplied less blower. The outdoor compressor units shown below can also be matched with blower coil indoor sections, and those are covered by separate installation manuals shipped with the respective blower coil units.

COOLING COIL DIMENSIONS (Inches)				
"A" Coils	A	B	C	Drain Pan Opening (W&L)
A18A*	18	20-1/2	11-1/4	12-1/4 x 15-1/4
A30A*	18	20-1/2	18	12-1/4 x 15-1/4
A36A*	18	20-1/2	16	12-1/4 x 15-1/4
A42A*	22	20-1/2	18	14-3/4 x 15-1/4
A48A*	22	20-1/2	22	14-3/4 x 15-1/4
A60A*	25	20-1/2	24	16 x 15-1/4

NOMENCLATURE EXPLANATION - EXAMPLE:

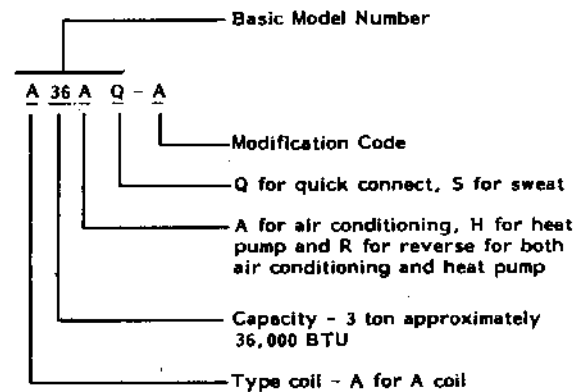

TABLE 1.

APPROVED MATCHED COMBINATIONS, RATED CFM STATIC PRESSURE DROP, ORIFICE PART NUMBER AND DIAMETER ①						
Condensing Unit Model Number	Evaporator Coil Model Number	Rated Airflow		Recommended Air Flow Range	Orifice Part No.	Orifice Diameter(In.)
		CFM	Pressure Drop "H ₂ O" ②			
24UACQA 24UACSA	A18AQ-A A18AS-A	750	.20	640 - 825	5625-059 ③	.059
	A30AQ-A A30AS-A	825	.15	700 - 910	5625-063 ③	.063
30UACQA 30UACSA	A30AQ-A A30AS-A	1000	.20	850 - 1100	5625-063 ③	.063
	A36AQ-A A36AS-A	1125	.30	950 - 1240	5625-069 ④	.069
36UACQA 36UACSA 36UACSA-B	A36AQ-A A36AS-A	1200	.30	1020 - 1320	5625-069 ③	.069
	A42AQ-A A42AS-A	1380	.30	1170 - 1520	5625-069 ④	.069
	A48AQ-A A48AS-A	1450	.27	1230 - 1600	5625-069 ④	.069
	A42AQ-A A42AS-A	1325	.30	1125 - 1450	5625-078 ③	.078
42UACQA 42UACSA 42UACSA-B	A42AQ-A A42AS-A	1325	.30	1125 - 1450	5625-078 ③	.078
	A48AQ-A A48AS-A	1525	.30	1300 - 1675	5625-078 ④	.078
	A42AQ-A A42AS-A	1325	.30	1125 - 1450	5625-081 ④	.081
48UACQA 48UACSA 48UACSA-B	A42AQ-A A42AS-A	1325	.30	1125 - 1450	5625-081 ④	.081
	A48AQ-A A48AS-A	1525	.30	1300 - 1675	5625-081 ③	.081
	A48AQ-A A48AS-A	1500	.30	1275 - 1650	5625-092 ④	.092
60UACQA 60UACSA 60UACSA-B	A48AQ-A A48AS-A	1500	.30	1275 - 1650	5625-092 ④	.092
	A60AQ-A A60AS-A	1900	.30	1615 - 2100	5625-092 ③	.092
36HPQ7	A36AQ-A	1200	.30	1020 - 1320	5625-067 ⑤	.067
30HPQ6	A36AQ-A	1130	.26	950 - 1240	5625-067 ⑤	.067
37ECS1	A36AS-A	1200	.30	1020 - 1320	5625-069 ③	.069
42ECS1	A42AS-A	1450	.30	1230 - 1600	5625-078 ③	.078
	A48AS-A	1450	.25	1230 - 1600	5625-078 ⑤	.078
48ECS2	A48AS-A	1500	.25	1275 - 1650	5625-081 ③	.081
60ECS1	A60AS-A	1900	.30	1615 - 2100	5625-092 ③	.092

IMPORTANT INSTALLER NOTE:

- ① All coils are suitable for up or down airflow direction.
- ② Measured across the evaporator coil assembly, including drain pan.
- ③ This orifice is shipped installed in the coil. When this combination of condensing unit and indoor coil is used, the orifice is properly sized.
- ④ Proper diameter orifice is NOT installed in the indoor coil. Proper orifice diameter is shipped with the outdoor unit packaged with its installation instructions. The orifice MUST be replaced with the proper orifice shown.
- ⑤ Proper diameter orifice is not installed in indoor coil. Proper orifice diameter must be ordered separately. The orifice must be replaced with proper orifice shown.

EXPANSION DEVICE

2

The flow control orifice provides the function of the expansion device as well as distributes the refrigerant equally to all evaporator circuits. It features a "take apart" brass body which houses a removable piston-orifice assembly which meters the proper amount of refrigerant flow and serves as the expansion device. This orifice can be removed and replaced.

The orifice shipped installed with the Flow Control and coil is sized for the most popular evaporator to outdoor unit combination (size to size). Example: Outdoor unit 36UAC1S-A with A38AS-A indoor coil. For other combinations of indoor coil to outdoor unit application, the orifice in the flow control device **MUST** be changed to the size shown in the chart on Table 1. An additional proper sized orifice to be used with each outdoor unit is shipped packaged in the envelope with the installation instructions, with each outdoor unit. The installer should mark the size of the orifice installed on the rating plate of the indoor coil. The diameter of the orifice is stamped on the side of the brass orifice and on the plastic bag. Example: 063 indicates the orifice is .063" inside diameter.

CAUTION: Be sure there is no dirt introduced into the distributor - orifice assembly. Be sure and install the orifice with the bullet nose pointing in the proper direction as shown in figure 1. Failure to do so will result in improper operation.

NOTE: If the orifice does not have to be changed, skip the instructions outlined further in figure 1 and proceed to figures 2 or 3 as applicable.

FLOW CONTROL ASSEMBLY FIELD RESTRICTOR REPLACEMENT INSTRUCTIONS

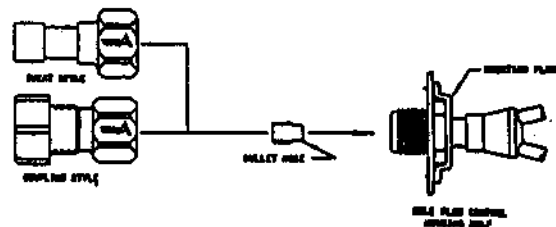

FIGURE 1.

NOTE: DO NOT CONNECT LINE SETS!
If restrictor needs to be changed, change out restrictor first.

- STEP 1 Remove charge/pressure from indoor unit (if necessary - coupling style).
- STEP 2 Disassemble Flow Control Assembly by turning body hex.
- STEP 3 If existing restrictor has not dropped out of the body when disassembled, remove by using a pin or paper clip. Discard this original restrictor.
- STEP 4 Insert properly sized restrictor fully into the flow control body with rounded "bullet" nose towards the unit as shown. Insure the restrictor stays inserted in body before connecting mating half. See Table 1 for proper size.
- STEP 5 Thread assembly halves together by hand to insure proper mating of threads and tighten until bodies "bottom" or a definite resistance is felt.
- STEP 6 Using a marker pen or ink pan, mark a line lengthwise from the union nut to the bulkhead. Then tighten an additional 1/8 turn (or 1 hex flat). The misalignment of the line will show the amount the assembly has been tightened. This final 1/8 turn is necessary to insure the formulation of the leakproof joint.
- STEP 7 Complete piping and installation of unit per installation instructions. See Figure 2 for detailed assembly instructions for sweat type and Figure 3 for detailed assembly instructions for coupling type coils.

CAUTION WHEN USING 5780 SERIES COUPLINGS:

If coupling is ever disconnected, the Flow Control Assembly connection may also be loosened. If this should occur, care must be taken to avoid loss of the restrictor. If loosened, repeat Step 5 above to insure the reformation of leakproof joint.

FLOW CONTROL FIELD ASSEMBLY PROCEDURES SWEAT STYLE LINE SET

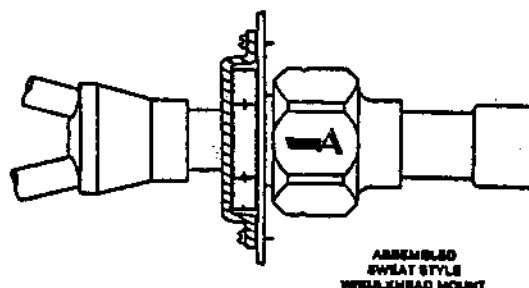

FIGURE 2.

- STEP 8 Route the suction and liquid lines between the indoor and outdoor units.
- STEP 9 The tubing should be cut square. Make sure it is round and free of burrs at the connecting ends, clean the tubing to prevent contaminants from entering the system.
- STEP 10 Wrap a wet rag around the union nut of the flow control assembly.
- STEP 11 Sparingly apply paste flux to the copper tube and insert into stub. Excessive or liquid flux can run inside assembly and cause corrosion. No flux is necessary if a low or zero silver braze alloy is used.
- STEP 12 After brazing, quench with a wet rag to cool the joint and remove any flux residue.
- STEP 13 Evacuate the lines and indoor coil before opening the base valves. Refer to instructions packed with the outdoor unit for details on setting the proper refrigerant charge.

**FLOW CONTROL FIELD ASSEMBLY PROCEDURES
PRE-CHARGE COUPLING LINE SET**

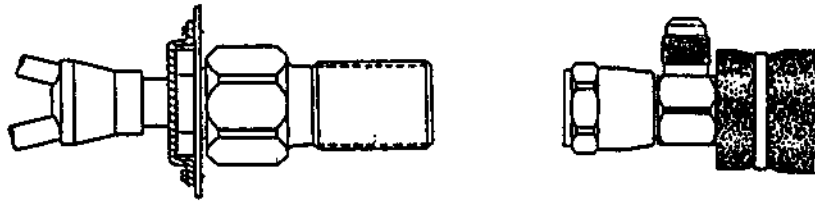

FIGURE 3.

- STEP 8 Route the suction and liquid line between the indoor and outdoor unit. CAUTION: Do not connect the tubing to the outdoor unit yet.
- STEP 9 Remove protector caps and plugs.
- STEP 10 If necessary, carefully wipe coupling seats and threaded surfaces with a clean cloth to prevent the inclusion of dirt or any foreign material in the system.
- STEP 11 LUBRICATE male half diaphragm and synthetic rubber seal with refrigerant oil. Thread coupling halves together by hand to insure proper mating of threads. Use proper size wrenches (on line set coupling body hex and on union nut) and tighten until coupling bodies "bottom" or a definite resistance is felt.
- STEP 12 Using a marker or ink pen, mark a line lengthwise from the coupling union nut to the bulkhead. Then tighten an additional 1/4 turn; the misalignment of the line will show the amount the coupling has been tightened. This final 1/4 turn is necessary to insure the formation of leakproof joint. If a torque wrench is used, torque values recommends 10 to 12 foot lbs.
- STEP 13 Evacuate the lines and indoor unit before connecting to the outdoor unit. Refer to the installation instructions packed with the outdoor unit for details on setting the proper refrigerant charge. NOTE: The lines and indoor coil do not have to be evacuated if they were not opened to the atmosphere to change the orifice.

A-COIL TYPES

Every coil must have the required minimum clearance between furnace heat exchanger and bottom of coil, and not exceed a maximum of two inches between the top of coil and bottom of horizontal ductwork.

When the ductwork takes off from only one side of the plenum, the minimum distance from top of coil to top of plenum is six inches.

A duct should never be located between the coil and the source of air supply. If your coil is larger than the top of your furnace, a transition is required with a minimum of three inches.

CAUTION: Be sure to seal area on all sides between coil drain pan and plenum to prevent air from bypassing coil.

It is important to provide a removable access door in the plenum slightly larger than the coil for servicing or cleaning the coil.

AIRFLOW PRESSURE DROP MEASUREMENT

A manometer or air draft gauge is required to check the air pressure drop across the indoor evaporator coil section.

The pressure (or positive) side of the gauge should connect to the air inlet (entering) side of the coil, and the suction (or negative) side of the gauge to the downstream (leaving) side of the coil. See Figure 4.

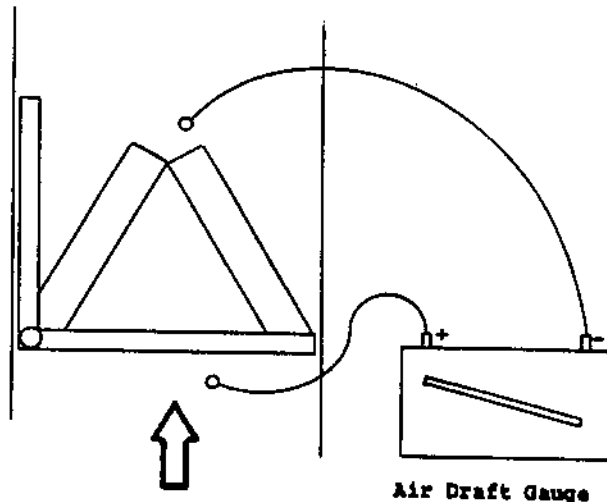

FIGURE 4.