

## **MODELS**

**P1024A1, P1030A1, P1036A1, P1045A1**

**HIGH EFFICIENCY**

**PACKAGED AIR CONDITIONER**

**INSTALLATION INSTRUCTIONS**

**FOR RESIDENTIAL AND COMMERCIAL  
HEATING / COOLING APPLICATIONS**



**ELECTRICAL DATA**

Model	Rated Volts & PH	Operating Voltage Range	Max. Unit Amps	Req'd Maximum External Fuses or Ckt. Breaker*	Minimum Circuit Ampacity	Field Power Wiring**	Ground Wire Size**
				Ckt. A	Ckt. A	Ckt. A	Ckt. A
P1024A	230/208-1	197-253	12.8	25	18	12	12
P1030A	230/208-1	197-253	18.2	35	23	10	10
P1036A	230/208-1	197-253	20.2	40	25	10	10
P1045A	230/208-1	197-253	25	50	32	8	10

\*Maximum time delay fuse or HACR type circuit breaker.  
 \*\*60°C copper wire size. Basic unit only.

**OPTIONAL FIELD-INSTALLED ELECTRIC HEATER TABLE**

Heater Package Model No.	Unit Volts Phase	Heater Kw & Capacity @ 240V		Heater Kw & Capacity @ 208 Volts		Heater Amps @ 240V	Heater Internal Fuses	Circuit B				
		Kw	Btuh	Kw	Btuh			Number Field Ckts.	Minimum Circuit Ampacity	Max. Over-Current Protection	Field Power Wiring	Ground Wire Size
EH3PA-A05	240/208-1	5	17,100	3.75	12,800	20.8	30/60	1	26	30	10	10
EH3PA-A08	240/208-1	8	27,300	6	20,500	33.3		1	42	45	6	10
EH3PA-A10	240/208-1	10	34,100	7.5	26,000	41.7		1	53	60	6	10
EH3PA-A15	240/208-1	15	51,200	11.25	38,400	62.5		1	79	80	3	8
EH3PA-B09	240/208-3	9	30,700	6.75	23,000	21.7		1	28	30	10	10
EH3PA-B15	240/208-3	15	51,200	11.25	38,400	36.2		1	46	50	6	10
EH5PA-A05	240/208-1	5	17,100	3.75	12,800	20.8	30/60 60/60	1	26	30	10	10
EH5PA-A10	240/208-1	10	34,100	7.5	26,000	41.7		1	53	60	6	10
EH5PA-A15	240/208-1	15	51,200	11.25	38,400	62.5		1	79	80	3	8
EH5PA-A20	240/208-1	20	68,200	15	51,200	83.2		1	104	110	2	6
EH5PA-B09	240/208-3	9	30,700	6.75	23,000	21.7		1	28	30	10	10
EH5PA-B15	240/208-3	15	51,200	11.25	38,400	36.2		1	46	50	6	10
EH5PA-B18	240/208-3	18	61,400	13.5	46,100	43.4	1	55	60	6	10	

- ① Time Delay fuses or "HACR Type" circuit breakers must be used for 60 and smaller sizes. Standard fuses or circuit breakers are suitable for sizes 70 and larger.
- ② Based on wire suitable for 60°C. Other wiring materials must be rated for marked "Minimum Circuit Ampacity" or greater.
- ③ Based upon Table 250-95 of N.E.C. 1984. See electrical data for basic heat pump for Ckt.A wiring specification requirements.
- ④ For ampacities over 100 amperes use wire suitable for at least 75°C.

**IMPORTANT:** While this electrical data is presented as a guide, it is important to electrically connect, properly size fuses and conductor wires in accordance with the National Electrical Code and all existing local codes.

**OPTIONAL FIELD-INSTALLED HEATER PACKAGES ARE ONLY TO BE USED WITH THE AIR CONDITIONER MODELS AS INDICATED BELOW**

Heater Model No.	Volts & Ph	P1024A	P1030A	P1036A	P1045A
EH3PA-A05	240-1	1	1	1	
EH3PA-A08		1	1	1	
EH3PA-A10		1	1	1	
EH3PA-A15		1	1	1	
EH3PA-B09	240-3	*	*	*	
EH3PA-B15		*	*	*	
EH5PA-A05					1
EH5PA-A10					1
EH5PA-A15					1
EH5PA-A20					1
EH5PA-B09					*
EH5PA-B15					*
EH5PA-B18					*

- 1 - Standard application - Heater volts and phase same as basic unit.
- \* - Alternate application - Heater volts and phase different from basic unit.

## IMPORTANT

The equipment covered in this manual is to be installed by trained, experienced service and installation technicians. All duct work, supply and return, must be properly sized for the design air flow requirement of the equipment. ACCA is an excellent guide to proper sizing. All duct work or portions thereof not in the conditioned space, should be properly insulated in order to both conserve energy and prevent condensation or moisture damage.

## SHIPPING DAMAGE

Upon receipt of equipment, the carton should be checked for external signs of shipping damage. If damage is found, the receiving party must contact the last carrier immediately, preferably in writing, requesting inspection by the carrier's agent.

## GENERAL

The refrigerant system is completely assembled and charged. All internal wiring is complete.

The unit is designed for use with or without duct work. Flanges are provided for attaching the supply and return ducts.

These instructions explain the recommended method to install the air cooled self-contained unit and the electrical wiring connections to the unit.

These instructions and any instructions packaged with any separate equipment required to make up the entire air conditioning system should be carefully read before beginning the installation. Note particularly "Starting Procedure" and any tags and/or labels attached to the equipment.

While these instructions are intended as a general recommended guide, they do not supersede any national and/or local codes in any way. Authorities having jurisdiction should be consulted before the installation is made.

## INSTALLATION

Size of unit for a proposed installation should be based on heat loss calculation made according to methods of National Warm Air Heating and Air Conditioning Association. The air duct should be installed in accordance with the Standards of the National Fire Protection Association for the Installation of Air Conditioning and Ventilating Systems of Other Than Residence Type, NFPA No. 90A, and Residence Type Warm Air Heating and Air Conditioning Systems, NFPA No. 90B. Where local regulations are at a variance with instructions, installer should adhere to local codes.

## LOCATION

The unit must be located outside, or in a well ventilated area. It must not be in the space being heated or cooled. A sound absorbing material should be considered if the unit is to be installed in such a position or location that might cause transmission of sound or vibration to the living area or adjacent buildings.

## TYPICAL INSTALLATIONS

1. Roof-Mounted - The unit is mounted on a sturdy base on the roof of the building. Return air to the unit is brought through a single return grille (grilles with built-in filters are best, since they enable easy access for filter changing). Return air ducts are attached to the lower section of the front panel. Supply air is brought from the unit to attic duct work or to a furred down hall. Supply air duct is attached to the top of the front panel. CAUTION: All outdoor duct work must be thoroughly insulated and weatherproofed. All attic duct work must be thoroughly insulated. One inch thick insulation with suitable vapor barrier is recommended for both outdoor and attic runs. In roof-top installation, as in all installations, the unit must be level from side to side. However, the unit should have a pitch along the length to assure complete external drainage of precipitation.

2. Crawl Space - Duct work installed in crawl space must be well insulated and provided with a vapor barrier. In addition, the crawl space must be thoroughly ventilated and provided with a good vapor barrier as a ground cover. It is most desirable to install the unit outdoors, rather than inside the crawl space, so that it will be readily accessible for service. In addition, it is necessary to dispose of the condensate from the outdoor coil on the heating cycle, and this is virtually impossible with the unit installed inside the crawl space.
3. Slab Mounted at Ground Level - This type installation is ideal for homes with slab floor construction, where a roof-mounted unit is not desired. The supply and return duct work can be run through a furred closet space.
4. Thru-The-Wall - This type installation requires a suitable framework to be fabricated, capable of withstanding the unit weight. Normally the unit will be installed so as to minimize supply and return duct work.
5. Other Installations - Many other installations are possible with the packaged air conditioner. No matter what the installation, always consider the following facts:
  - a. Insure that the discharge air is not obstructed in any way so as to cause operation difficulties.
  - b. The indoor coil drain pan is equipped with a coupling that must be piped through a condensate drain trap to a suitable drain.
  - c. Always mount the unit in such a position that it may be easily reached for servicing and maintenance.
  - d. Insure that the unit is clear so that proper air flow over the outdoor coil will be maintained.

RATED CFM AND E.S.P. (WET COIL - COOLING)			
Model	Rated CFM	Rated E.S.P.	Recommended Airflow Range
P1024A	800	.35	720 - 880
P1030A	1150	.35	1025 - 1275
P1036A	1275	.30	1150 - 1400
P1045A	1700	.25	1520 - 1850

## WIRING - MAIN POWER

Refer to the unit rating plate for wire sizing information and maximum fuse or "HACR Type" circuit breaker size. Each outdoor unit is marked with a "Minimum Circuit Ampacity." This means that the field wiring used must be sized to carry that amount of current. If field installed heaters are added to the basic unit, a second, separate power supply circuit will be required. The heater rating plate located adjacent to the basic unit rating plate will show the appropriate circuit ampacity, fuse size, etc. (Also see "Electrical Data" on page 1). Some models are suitable only for connection with copper wire, while others can be wired with either copper or aluminum wire. Each unit and/or wiring diagram will be marked "Use Copper Conductors Only" or "Use Copper or Aluminum Conductors." These instructions MUST BE adhered to. Refer to the National Electrical Code for complete current-carrying capacity data on the various insulation grades of wiring material.

The electrical data lists fuse and wire sizes (60°F copper) for all models, including the most commonly used heater sizes. Also shown are the number of field power circuits required for the various models with heaters.

The unit rating plate lists "Maximum Time Delay Fuse" or "HACR Type" circuit breaker that is to be used with the equipment. The correct size must be used for proper circuit protection and also to assure that there will be no nuisance tripping due to the momentary high starting current of the compressor motor.

**PRESSURE SERVICE PORTS**

High and low pressure service ports are installed on all units so that the system operating pressures can be observed. Pressure curves can be found later in the manual covering all models on both cooling and heating cycles. It is imperative to match the correct pressure curve to the unit by model number.

**AIR FILTERS**

Air filters for the return air side of the system are not provided as part of the basic piece of equipment because of the various types of application for these models, and must be field supplied and installed as part of the final installation.

Prior thought should be given to return air location and placement of the air filter(s). The air filter(s) must be of adequate size and readily accessible to the operator of the equipment. Filters must be adequate in size and properly maintained for proper operation. If this is not done, excessive energy use, poor performance, and multiple service problems will result. **IT IS IMPOSSIBLE TO OVERSIZE AIR FILTERS.** Generous sizing will result in cleaner air and coils, as well as lower operating costs and extend the time between required changes. The following table shows minimum filter areas and recommended filter sizes. Actual filter sizes can vary with the installation due to single or multiple returns utilizing a filter/grille arrangement or being placed immediately ahead of the indoor coil face in the return air duct.

Model	Minimum Filter Area	Recommended Size
P1024A, P1030A P1036A	462 sq.in. (3.21 sq.ft)	15x30-5/8 x 1
P1045A	608 sq.in. (4.62 sq.ft)	(2) 16x20 x 1

NOTE: If Roof Hood Accessory is to be used, information on air filters may be found under that heading in this manual. Air filters are supplied as part of that package.

**REFRIGERANT CHARGE**

The correct system R-22 charge is shown on the unit rating plate. Optimum unit performance will occur with a refrigerant charge resulting in a suction line temperature (6" from compressor) as shown in the following table:

Model	Rated Airflow	95°F O.D.Temp.	82°F O.D.Temp.
P1024A	800	53 - 55	64 - 66
P1030A	1150	50 - 52	62 - 64
P1036A	1275	52 - 55	58 - 60
P1045A	1700	54 - 56	64 - 66

The above suction line temperatures are based upon 80°F dry bulb/67° wet bulb (50% R.H.) temperature and rated airflow across the evaporator during cooling cycle.

**CRANKCASE HEATERS**

All units are provided with compressor crankcase heat. The units have an insertion well-type heater located in the lower section of the compressor housing. This is a self-regulating type heater that draws only enough power to maintain the compressor at a safe temperature.

Some form of crankcase heat is essential to prevent liquid refrigerant from migrating to the compressor, causing oil pump out on compressor start-up and possible valve failure due to compressing a liquid.

The following decal is affixed to all outdoor units detailing start-up procedure. This is very important. Please read carefully.

**IMPORTANT**

**THESE PROCEDURES MUST BE FOLLOWED AT INITIAL START-UP AND AT ANY TIME POWER HAS BEEN REMOVED FOR 12 HOURS OR LONGER.**

**TO PREVENT COMPRESSOR DAMAGE WHICH MAY RESULT FROM THE PRESENCE OF LIQUID REFRIGERANT IN THE COMPRESSOR CRANKCASE**

1. MAKE CERTAIN THE ROOM THERMOSTAT IS IN THE "OFF" POSITION. (THE COMPRESSOR IS NOT TO OPERATE).
2. APPLY POWER BY CLOSING THE SYSTEM DISCONNECT SWITCH THIS ENERGIZES THE COMPRESSOR HEATER WHICH EVAPORATES THE LIQUID REFRIGERANT IN THE CRANKCASE.
3. ALLOW 4 HOURS OR 60 MINUTES PER POUND OF REFRIGERANT IN THE SYSTEM AS NOTED ON THE UNIT RATING PLATE, WHICHEVER IS GREATER.
4. AFTER PROPERLY ELAPSED TIME THE THERMOSTAT MAY BE SET TO OPERATE THE COMPRESSOR.
5. EXCEPT AS REQUIRED FOR SAFETY WHILE SERVICING - DO NOT OPEN SYSTEM DISCONNECT SWITCH.

7061-081

**IMPORTANT INSTALLER NOTES**

For improved start-up performance wash the indoor coil with a dishwasher detergent.

**OPTIONAL ELECTRIC HEATERS**

These packaged air conditioners are manufactured without supplementary electric heaters. Supplementary heaters EH3PA series (to fit P1024A, P1030A, P1036A) and EH5PA series (to fit P1045A) are available for simple, fast field installation.

A separate field power circuit is required for the supplementary heaters.

Refer to the electrical data shown on page 1 for proper application information on all available heater combinations and what units they can be used with. It also shows the applicable circuit ampacities, fuse size and wire size for each heater combination.

Refer to the installation instructions packed with the heater for details on how to insert it into the basic unit.

If this unit is operated in cooling below a 65° outdoor ambient temperature, the installation of low ambient control (LAC-1) to unit is required.

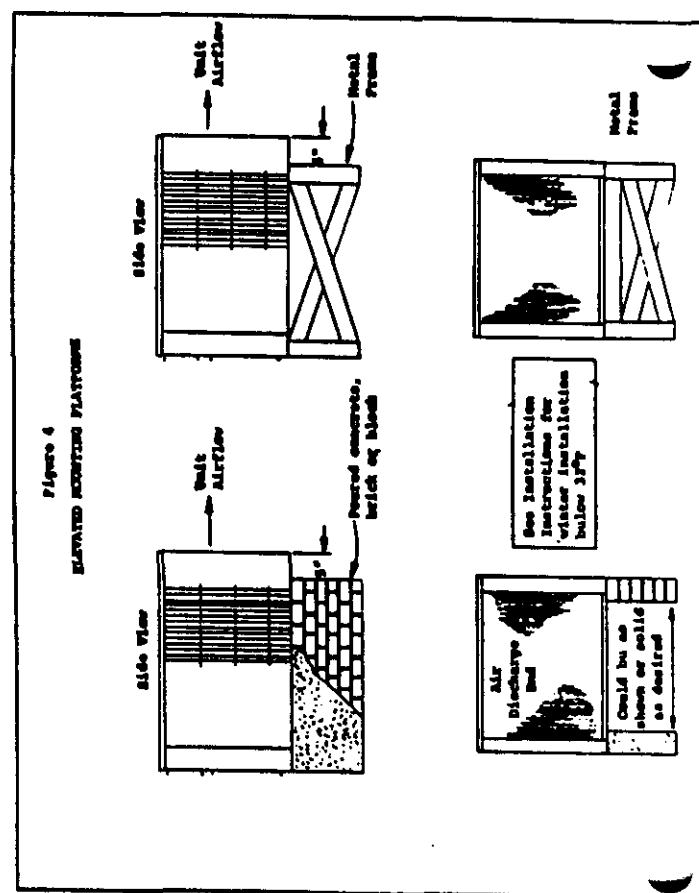
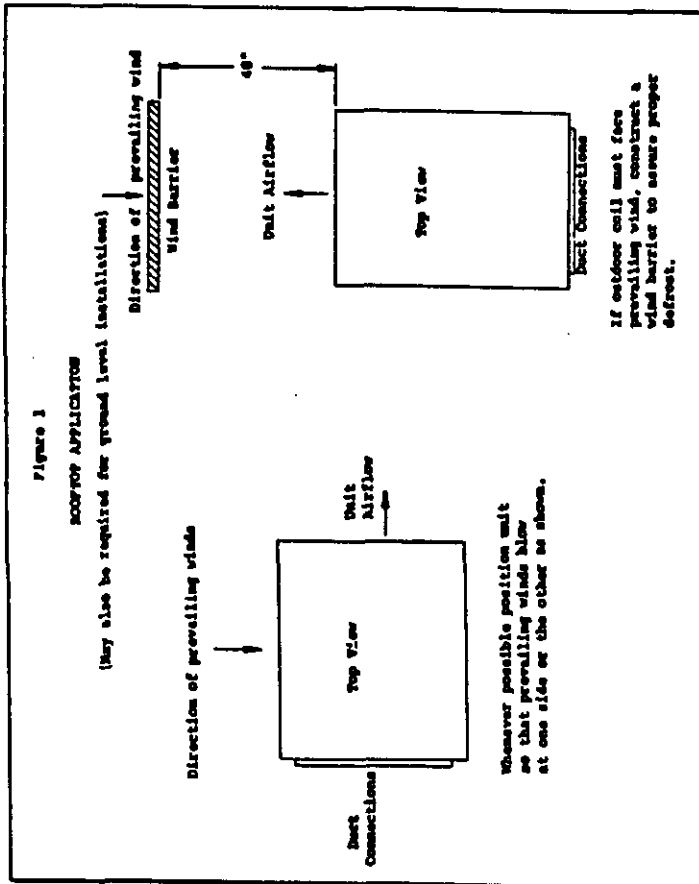
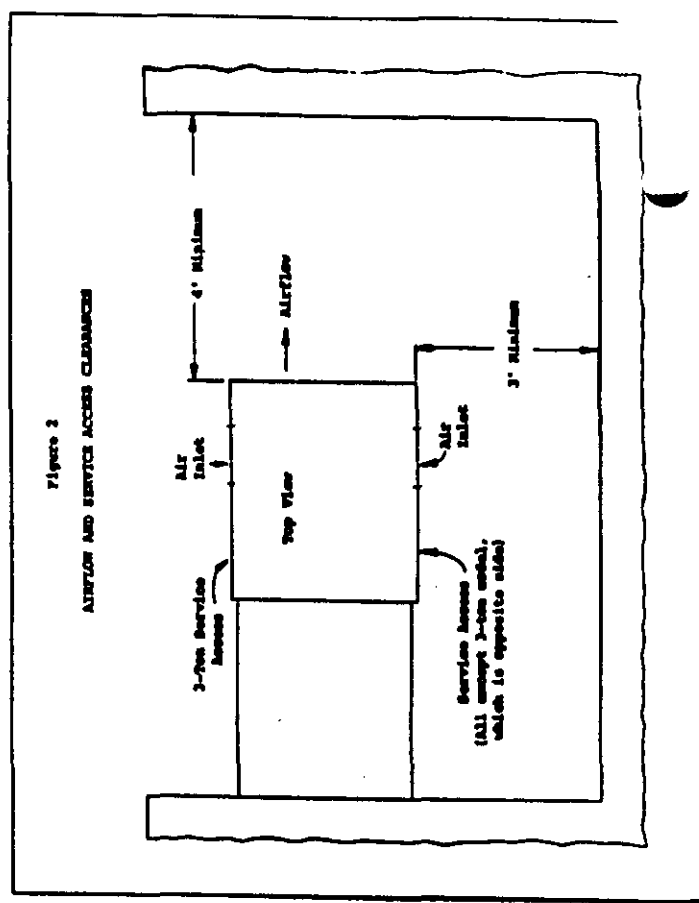
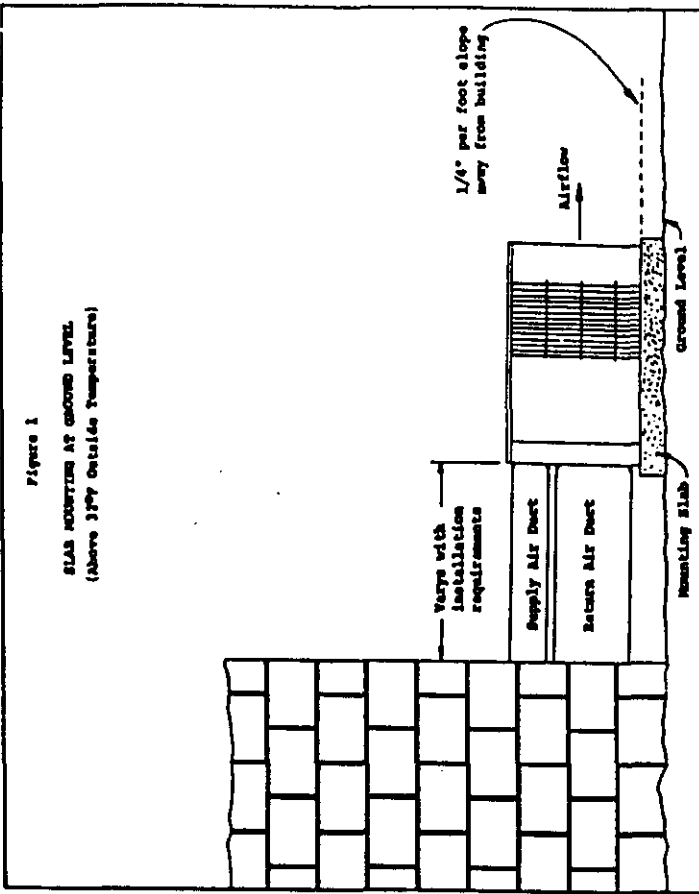

## PRE-FABRICATED ROOF CURB SPECIFICATIONS

**HEAVY GAUGE GALVANIZED WITH WOOD NAILING STRIP, WELDED/LEAKPROOF  
ONE PIECE CONSTRUCTION - READY TO INSTALL**

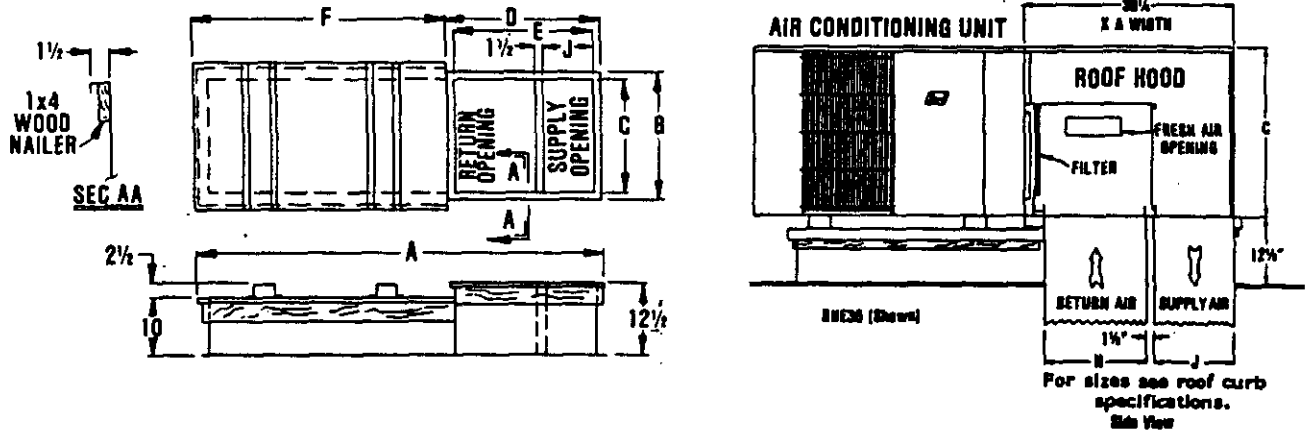

**CURB AND ROOF HOOD DETAILS**

	A	B	C*	D	E	F	J*	H*	Roof Hood Model	Heat Pump and Air Conditioning Units
P36 Curb	80-3/8	40-1/4	37-1/4	38-3/8	35-3/8	42	14-3/4	19-1/8	RHE36	P1024A, P1030A, P1036A
P60 Curb	82-3/8	44-1/8	41-1/8	38-3/8	35-3/8	44	14-3/4	19-1/8	RHE60	P1045A

**\*Duct Sizing Information**

Return Air Dimension "C" is length Dimension "H" is width	Supply Air Dimension "C" is length Dimension "J" is width
--	--

## FIELD FABRICATED CURBING

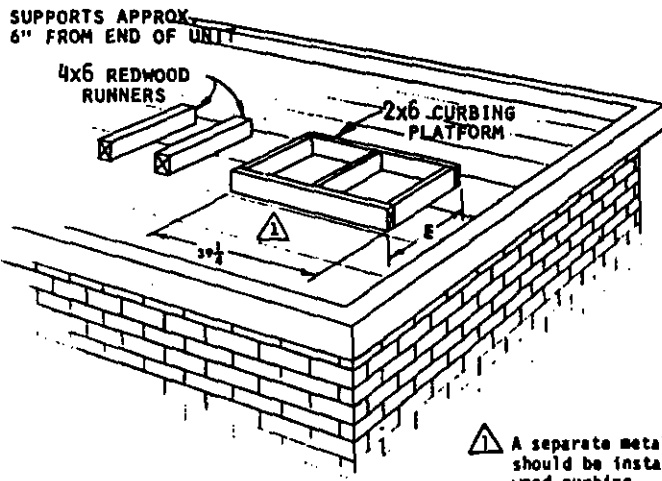

**⚠ A separate metal flashing should be installed around wood curbing. Caulk and seal all joints and weather-proof.**

ROOF HOOD MODEL	UNIT MODEL	E
RHE36	P1024A P1030A P1036A	41
RHE60	P1045A	44-7/8

Packaged Air Conditioner  
Model P1024A1

2/87

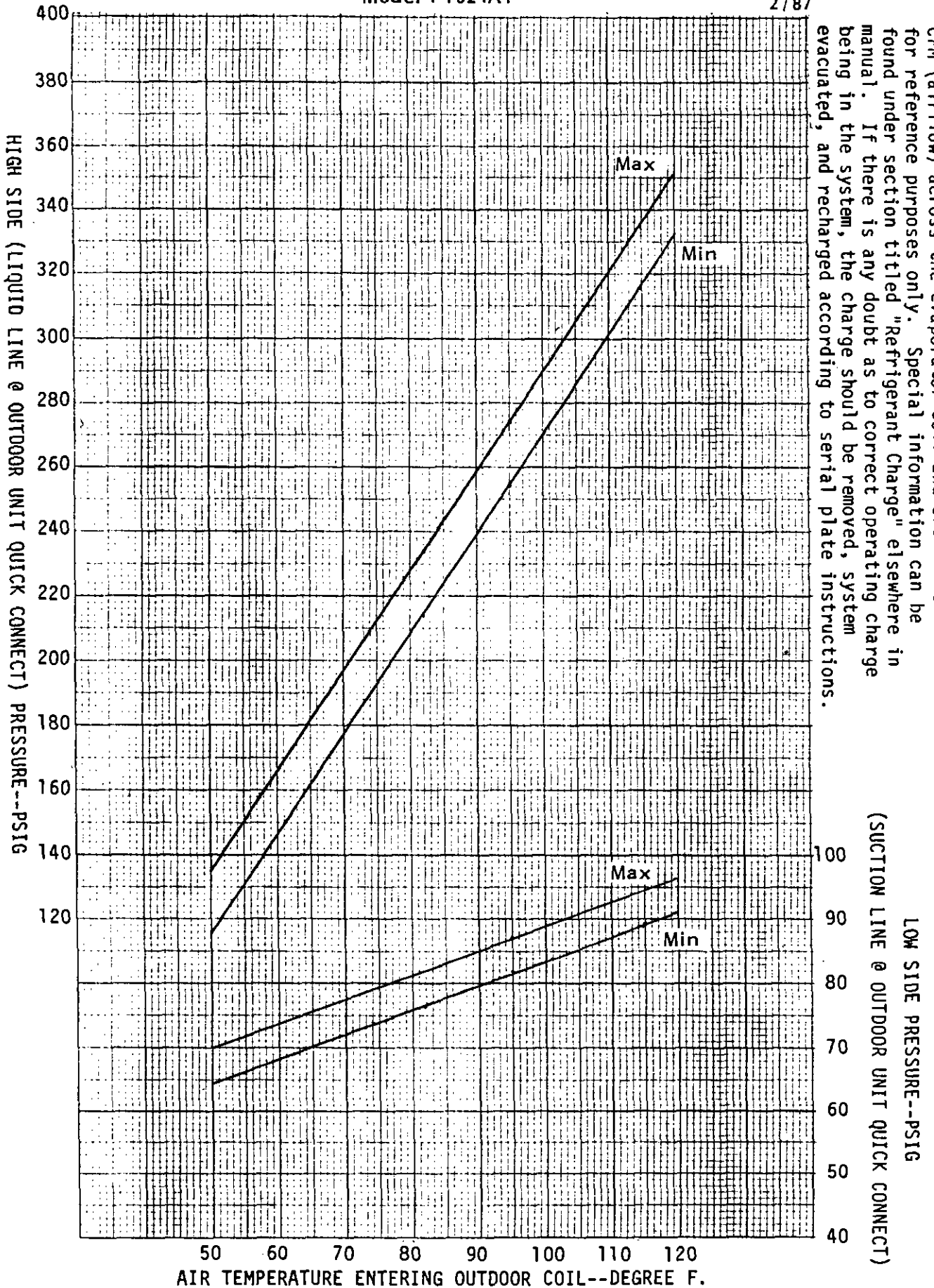



Packaged Air Conditioner  
Model P1030A1

2/87

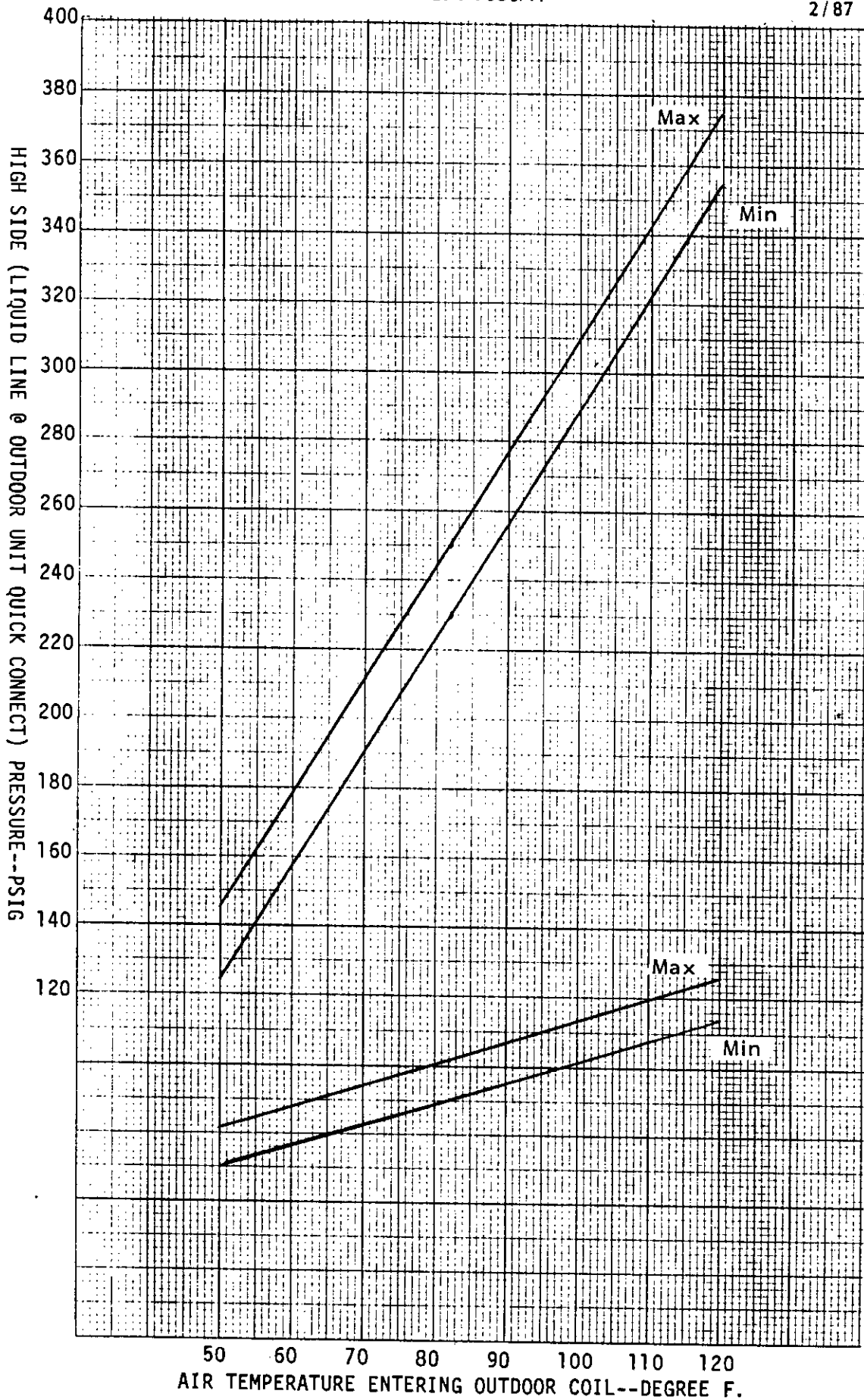

These curves are based upon 80°DB, 67°WB R.A. Temp. and Rated CFM (airflow) across the evaporator coil and should be used for reference purposes only. Special information can be found under section titled "Refrigerant Charge" elsewhere in manual. If there is any doubt as to correct operating charge being in the system, the charge should be removed, system evacuated, and recharged according to serial plate instructions.

LOW SIDE PRESSURE--PSIG  
(SUCTION LINE @ OUTDOOR UNIT QUICK CONNECT)

Packaged Air Conditioner  
Model P1036A1

2/87

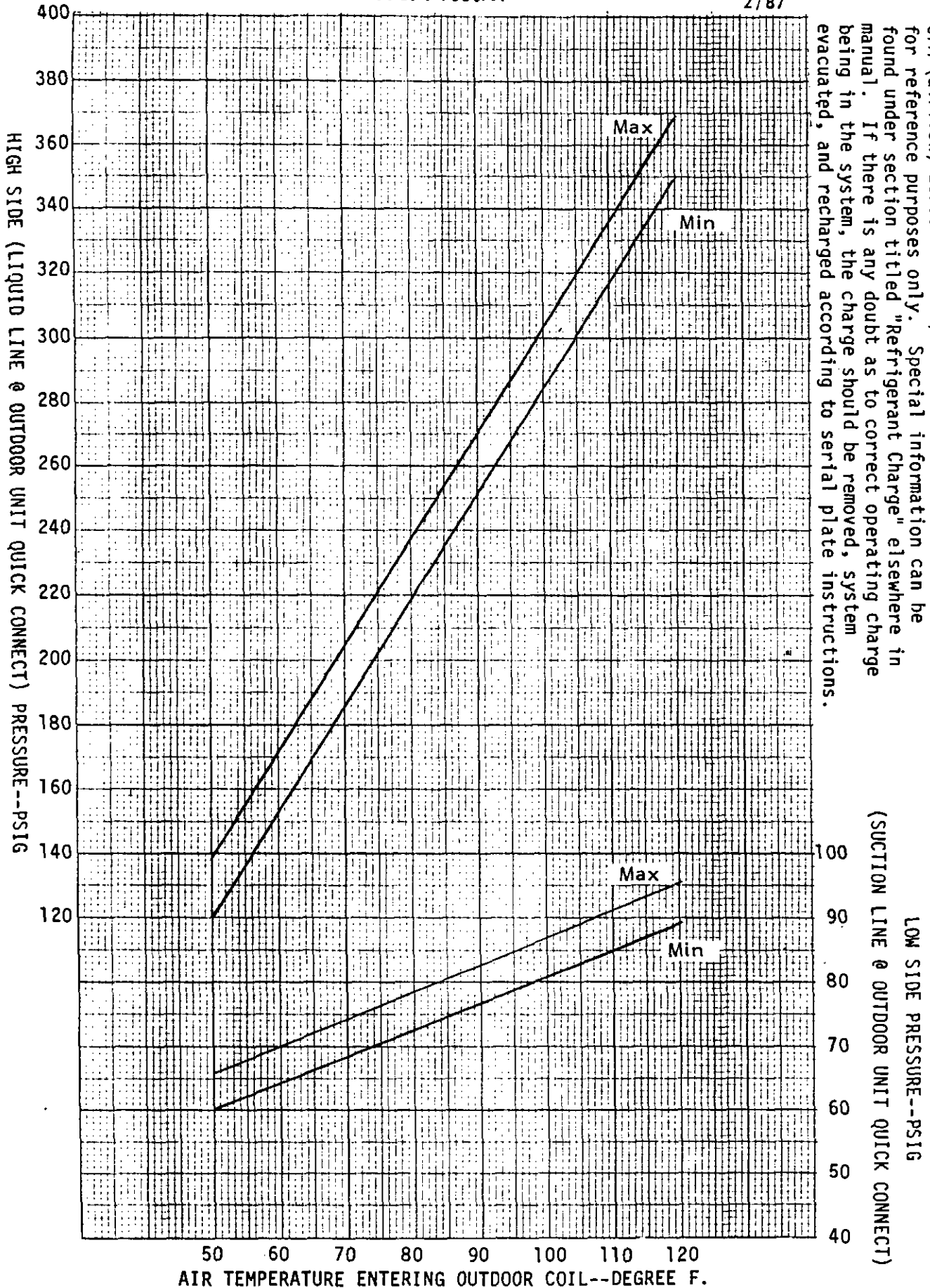

These curves are based upon 80°DB, 67°WB R.A. Temp. and Rated CFM (airflow) across the evaporator coil and should be used for reference purposes only. Special information can be found under section titled "Refrigerant Charge" elsewhere in manual. If there is any doubt as to correct operating charge being in the system, the charge should be removed, system evacuated, and recharged according to serial plate instructions.

Packaged Air Conditioner  
Model P1045A1

2/87

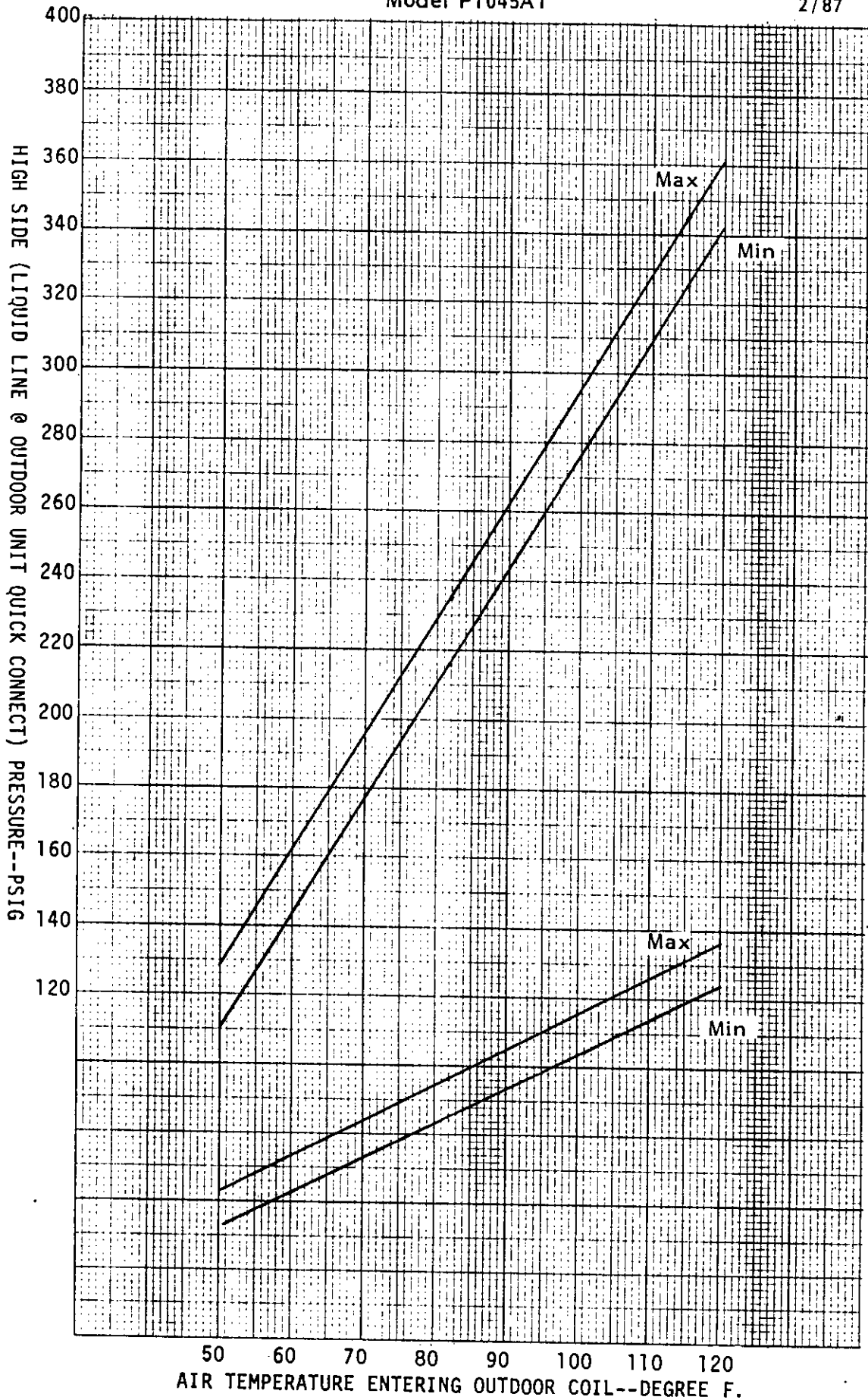

These curves are based upon 80°DB, 67°WB R.A. Temp. and Rated CFM (airflow) across the evaporator coil and should be used for reference purposes only. Special information can be found under section titled "Refrigerant Charge" elsewhere in manual. If there is any doubt as to correct operating charge being in the system, the charge should be removed, system evacuated, and recharged according to serial plate instructions.

LOW SIDE PRESSURE--PSIG  
(SUCTION LINE @ OUTDOOR UNIT QUICK CONNECT)

## PARTS LIST

## SINGLE PACKAGE AIR CONDITIONERS

6/87

Part No.	Description	P1024A1	P1030A1	P1036A1	P1045A1
*	Blower Housing	x	x	x	
*	Blower Housing 10-10				x
5152-008	Blower Wheel DD10-4A	x			
5152-005	Blower Wheel DD9-8A		x		
5152-013	Blower Wheel DD10-8A			x	
5152-015	Blower Wheel DD10-10A				x
8552-027	Capacitor - Comp. 25/370V	x			
8552-032	Capacitor - Comp. 35/370V		x		
8552-035	Capacitor - Comp. 40/370			x	
8552-002	Capacitor - Fan & Blower 5/370V	x	x	x	
8552-028	Capacitor 35/440V				x
8552-005	Capacitor 10/370V				x
8552-026	Capacitor 15/370V				x
5811-011	Capillary Tube - Cool	(2)			
5811-014	Capillary Tube - Cool		(2)		
5811-001	Capillary Tube - Cool			(5)	(6)
8000-098	Compressor H23B203ABCA	x			
8000-099	Compressor H23B283ABCA		x		
8000-052	Compressor CRG3-0250-PFV			x	
8000-058	Compressor CRJ3-0300-PFV				x
5051-035	Condenser Coil	x	x		
5051-050	Condenser Coil			x	
5051-051	Condenser Coil				x
8401-007	Contactora - Comp. 1P25A	x	x	x	x
5060-050	Evaporator Coil			x	
5060-037	Evaporator Coil	x	x		
5060-051	Evaporator Coil				x
5151-034	Fan Blade BT2026-2	x			
5151-004	Fan Blade TP2026		x	x	
5151-029	Fan Blade T10H08-2436				x
7051-015	Wire Grille	(2)	(2)	(2)	
7051-007	Wire Grille				(2)
7051-001	Condenser Grille	x	x	x	
7051-005	Condenser Grille				x
8105-032	Motor - Blower 1/3 hp ccw	x			
8105-024	Motor - Blower 1/3 hp ccw		x	x	
8106-015	Motor - Blower 1/2 hp				x
8103-016	Motor - Fan 1/5 hp cw	x			
8103-009	Motor - Fan 1/5 hp cw		x	x	
8105-021	Motor - Fan 1/3 hp				x
8200-003	Motor Mount - Blower	x	x	x	
8200-004	Motor Mount - Fan				x
8200-028	Motor Mount - Blower				x
8200-001	Motor Mount - Fan	x	x	x	
5451-011	Motor Mounting Part	x	x	x	x

**PARTS LIST**

**SINGLE PACKAGE AIR CONDITIONERS**

2/87

Part No.	Description	P1024A1	P1030A1	P1036A1	P1045A1
8201-008	Relay - Blower	x	x	x	x
5210-004	Strainer	x	x		
5210-009	Strainer				x
8607-006	Terminal Board 24V	x	x	x	x
8607-013	Terminal Block	x	x	x	x
5210-011	Strainer			x	
8407-034	Transformer 40VA	x	x	x	x
4063-116	Wiring Diagram		x	x	
4063-117	Wiring Diagram	x			
4064-113	Wiring Diagram				x

Minimum Net Billing \$15.00. Supersedes all previous lists.

Subject to change without notice.

\*Please order by model number.

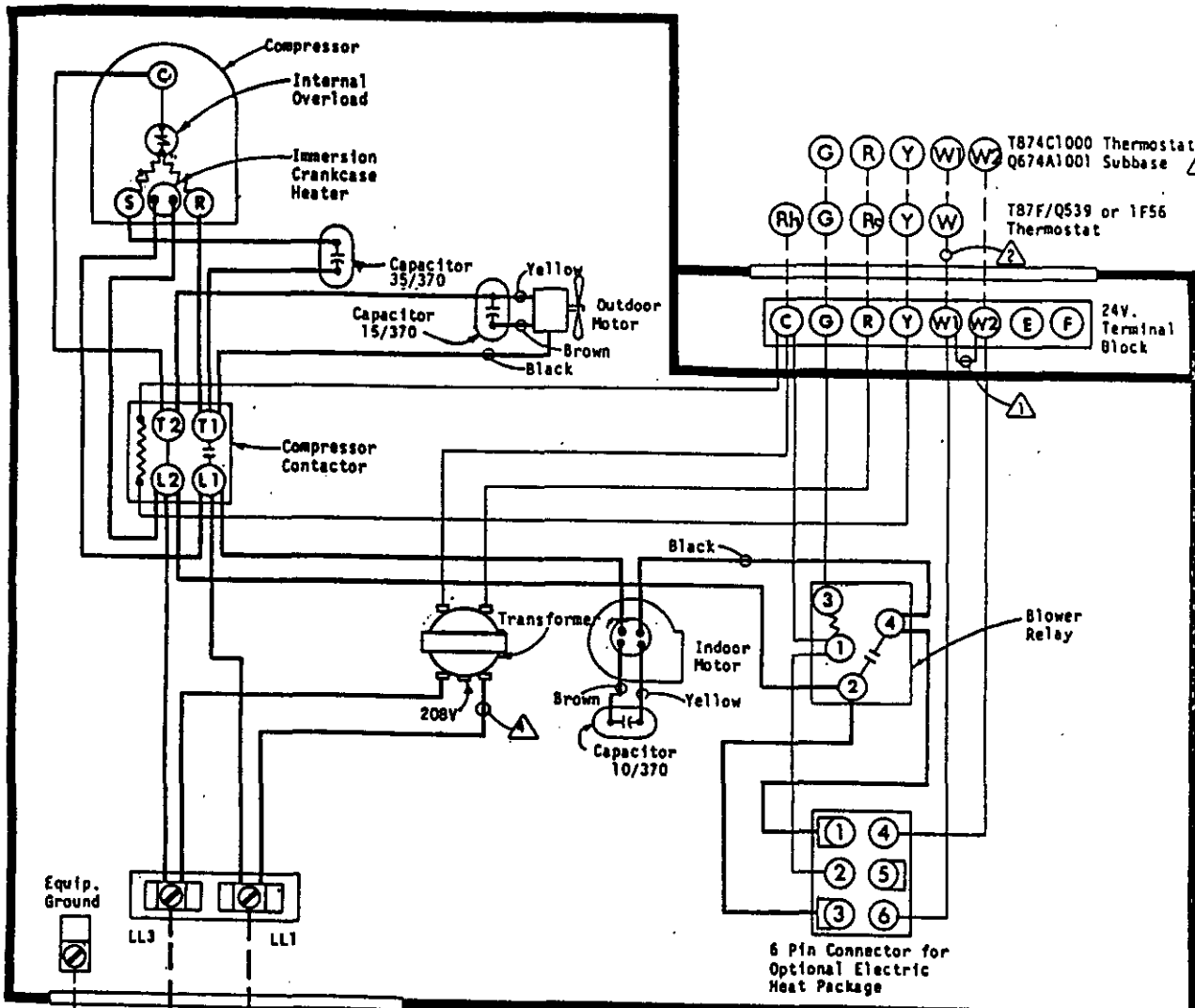

- ⚠ Remove jumper for two stage heat
- ⚠ Not required when Optional Heat Packages are not installed
- ⚠ Required only for use with Optional Electric Heat Packages: EHSPA-A15, EHSPA-A20, EHSPA-B12, EHSPA-B15, EHSPA-B18
- ⚠ For 208V. operation move this wire to 208V. transformer tap.

**USE COPPER OR ALUMINUM WIRE**

FACTORY WIRING	FIELD WIRING
Low Voltage ———	-----
High Voltage ———	-----

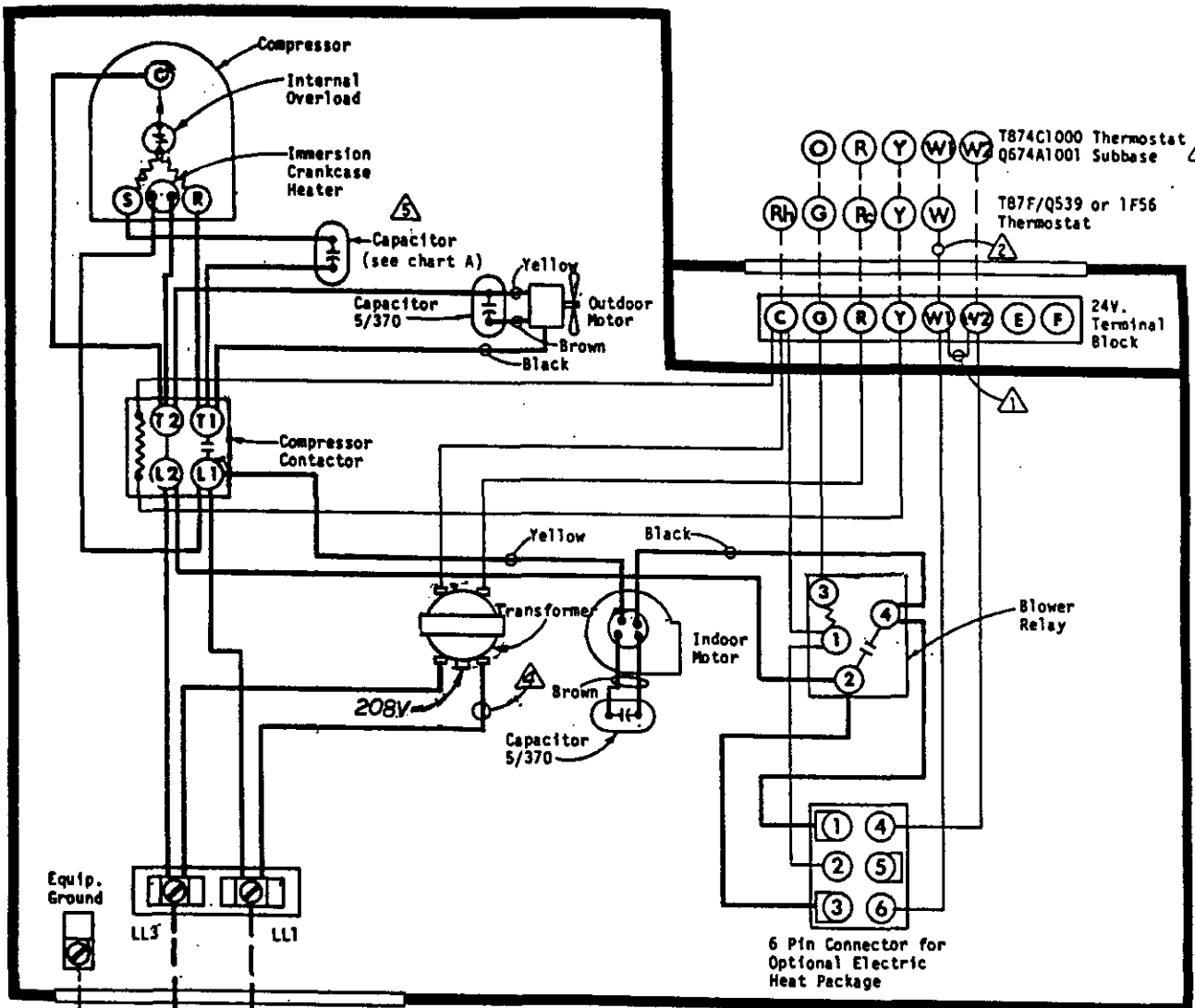

⚠ Remove jumper for two stage heat

⚠ Not required when Optional Heat Packages are not installed

⚠ Required only for use with Optional Electric Heat Packages: EH3PA-A15, EH3PA-B12, EHP3PA-B15. When two stage heat is desired.

⚠ For 208V operation move this wire to 208V transformer tap.

⚠ Compressor Run Capacitor is located on the back of the Blower Partition

CHART A

MODEL NO.	CAP.
P1030A1	35/370
P1036A1	40/370

USE COPPER OR ALUMINUM WIRE

FACTORY WIRING      FIELD WIRING  
 Low Voltage ————  
 High Voltage ————

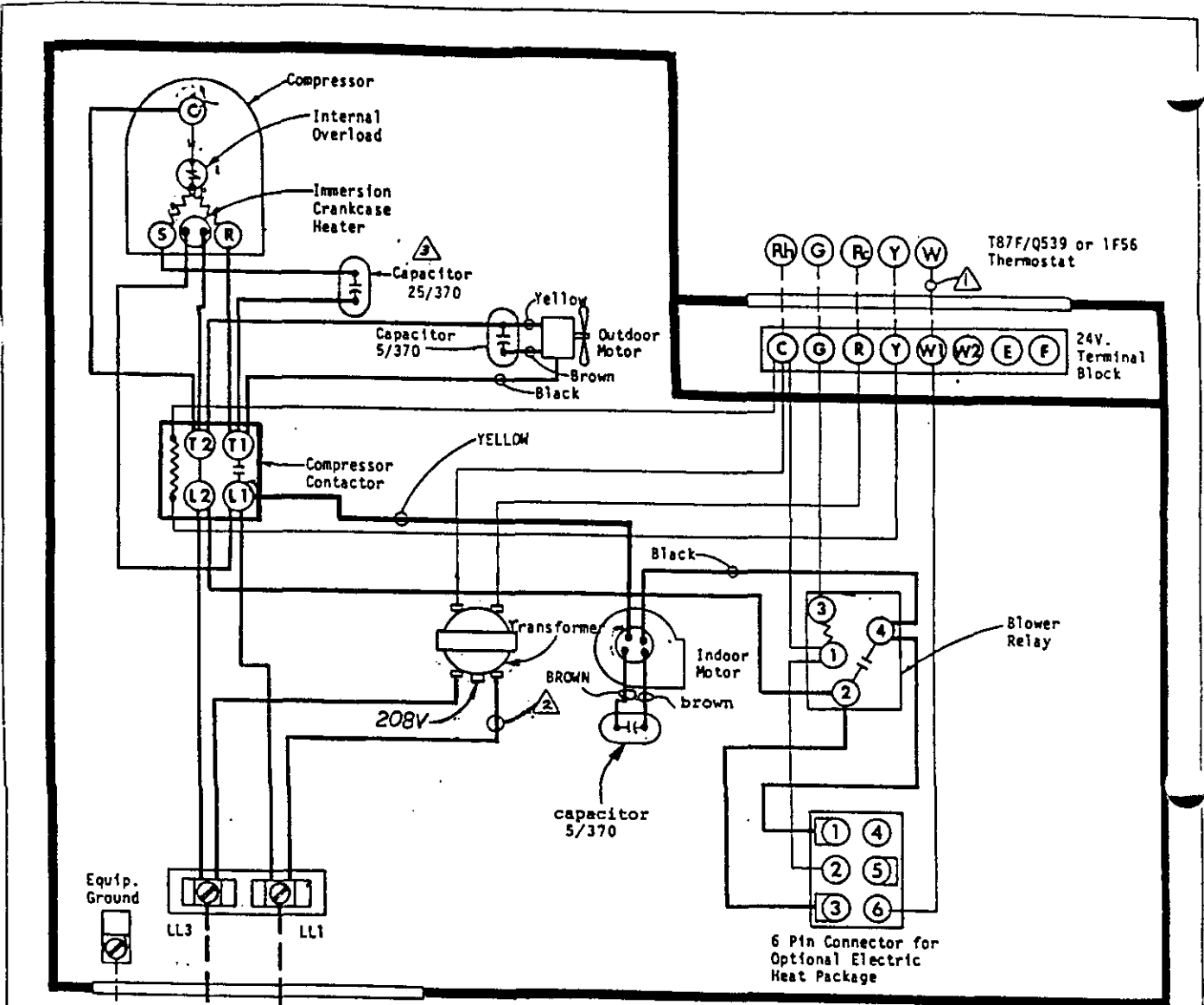

- ⚠ Not required when Optional Heat Packages are not installed
- ② For 208V operation move this wire to 208V transformer tap.
- ③ Compressor Run Capacitor is located on the back of the Blower Partition

USE COPPER OR ALUMINUM WIRE

FACTORY WIRING	FIELD WIRING
Low Voltage _____	Low Voltage _____
High Voltage _____	High Voltage _____