

INSTALLATION INSTRUCTIONS

MODELS

HI - BOY
LO - BOY
COUNTERFLOW

HIGH ECONOMY GAS FURNACES

APPLICATION

This is a forced air gas furnace for indoor installation in building constructed on site. The furnace installation must conform with local building codes and ordinances or, in their absence with the National Fuel Gas Code, ANSI Z223.1-1984, and the National Electrical Code, ANSI/NFPA 70-1987. It is the personal responsibility and obligation of the purchaser to contract a qualified installer to assure that installation is adequate and is in conformance with governing codes and ordinances.

HIGH ALTITUDE APPLICATIONS

Rating of gas utilization equipment are based on sea level operation and need not be changed for operation at elevations up to 2,000 feet. For operation at elevations above 2,000 feet and, in the absence of specific recommendations from the local authority having jurisdiction, equipment ratings shall be reduced at the rate of 4 percent for each 1,000 feet above sea level before selecting appropriately sized equipment. (Ref. ANSI Z223.1-1984, Par. 8.12).

TRANSPORTATION DAMAGE

All units are packed securely in shipping container. All units should be carefully inspected upon arrival for damage. In the event of damage, the consignee should:

1. Note on delivery receipt of any damage to container.
2. Notify carrier promptly, and request an inspection.
3. In case of concealed damage, the carrier must be notified as soon as possible within 15 days after delivery.
4. Claims for any damage, apparent or concealed, should be filed with the carrier, using the following supporting documents, and within the 9-month statute of limitations.
 - a) Original Bill of Lading, certified copy, or indemnity bond.
 - b) Original paid freight bill or indemnity in lieu thereof.
 - c) Original invoice or certified copy thereof showing trade and other discounts or deductions.
 - d) Copy of the inspection report issued by carrier's representative at the time damage is reported to carrier.

The carrier is responsible for making prompt inspection of damage and for a thorough investigation of each claim.

LOCATING THE FURNACE

When selecting a location for the furnace, observe the following points:

1. The furnace should be set on a level floor. If the floor may become damp or wet at times, the furnace should be supported above the floor using a concrete base, bricks, patio blocks, etc., making sure adequate support is available for the furnace. Counterflow furnaces require use of combustible floor base if installed on combustible surface. The combustible floor base is not part of the furnace and must be ordered separately. Furnaces approved for installation on combustible flooring shall not be installed directly on carpeting, tile or other combustible material other than wood flooring.
2. The furnace should be as centralized as practical with respect to the air distribution system.
3. Provisions must be made for venting combustion products outdoors through an individual venting system.
4. Provide at least the minimum clearances specified in Fig. 1 for fire protection, proper operation and service access. These clearances must be permanently maintained. The combustion and ventilating air openings in the front of the furnace must never be obstructed.
5. Minimum service clearances must take precedence over fire protection clearances (minimum installation clearances).
6. All models are approved for a utility room or closet installation.
7. A gas-fired furnace installed in a residential garage must be installed so that the burners and ignition source are located not less than 18 inches above the floor, and the furnace must be located or protected to avoid physical damage by vehicles.

FIGURE 1. MINIMUM CLEARANCES (INCHES)

Model	Minimum Installation Clearances							Minimum Service Clearance		
	Top	Front	Vent	Back	Left Side	Right Side	Floor	Front	Sides	Back
86,000 Lo-Boy	1	6	6*	0	0	1 ⁺	C	24	18 ^①	24
115,000 Lo-Boy	1	6	6*	0	0	0	C	24	18 ^①	24
145,000 Lo-Boy	1	6	6*	0	0	0	C	24	18 ^①	24
60,000 Hi-Boy	1	6	6*	0	0	4 ⁺	C	24	0	0
86,000 Hi-Boy	1	6	6*	0	0	1 ⁺	C	24	0	0
115,000 Hi-Boy	1	6	6*	0	0	0	C	24	0	0
60,000 Counterflow	1	6	6*	0	0	4 ⁺	NC	24	0	0
86,000 Counterflow	1	6	6*	0	0	1 ⁺	NC	24	0	0
115,000 Counterflow	1	6	6*	0	0	0	NC	24	0	0

① Minimum clearance at least one side for access to rear of furnace.
 * Clearance may be 1 inch when Type B-1 vent is used.
 + Clearance may be 0 inch when Type B-1 vent is used.
 C Floor may be combustible material.
 NC Floor must be non-combustible. Can be installed on combustible flooring only when installed on special base available from factory.

DUCT WORK

The air distribution system should be designed and installed in conformance with Manuals 7 or 7A published by Air Conditioning Contractors of America (ACCA), as set forth in their Manual K.

CAUTION

When a furnace is installed so that supply ducts carry air circulated by the furnace to areas outside the space containing the furnace, the return air must also be handled by a duct(s) sealed to the furnace casing and terminating outside the space containing the furnace. This is to prevent drawing possible hazardous combustion products into the circulated air.

When the furnace is used in connection with a cooling unit*, the furnace shall be installed parallel with or on the upstream side of the cooling unit to avoid condensation in the heating element. With a parallel flow arrangement, the dampers or other means used to control flow of air shall be adequate to prevent chilled air from entering the furnace and, if manually operated, must be equipped with means to prevent operation of either unit, unless the damper is in the full heat or cool position.

*A cooling unit is an air conditioning coil, heat pump coil or chilled water coil.

COMBUSTION AND VENTILATION AIR

The furnace and furnace room must have an adequate supply of air for safe combustion and ventilation. The provisions necessary to assure an adequate air supply will vary depending upon differences in the tightness of house construction and in the location of the furnace. Methods of providing air from some typical situations are described below. Consult local codes and ordinances for requirements applicable to your specific furnace installation conditions and comply with them. In the absence of local codes and ordinances, comply with the National Fuel Gas Code, ANSI Z223.1-1984.

EXAMPLE 1 -- FURNACE LOCATED IN AN UNCONFINED SPACE

- A. If the furnace is located in a basement or other large, open area of a conventionally built house (loose construction), the air that leaks into the building normally will provide an adequate air supply.

EXAMPLE 2 -- FURNACE LOCATED IN A CONFINED SPACE

- A. When the furnace is in a closet or utility room, install two open grilles in a wall or door opening to the rest of the house. Each grille must have a free area of at least one square inch for each 1000 Btuh of total input rating of all gas appliances in the confined space. Refer to Figure 2. The grilles must communicate with other open areas having adequate air infiltration from outdoors.
- B. If the building is tightly constructed, not enough outside air may enter for safe combustion. Install a fresh air duct from a point near the burners to the outside or to a ventilated attic or crawl space. Refer to Figure 3. This duct must have a free area of at least one square inch for each 4000 Btuh of total input of all gas appliances in the space. The minimum dimension of a rectangular duct must not be less than three inches.

CAUTION

When a furnace is installed in a closet or utility room, never use this room as a return air plenum.

FIGURE 2 — FURNACE LOCATED IN CONFINED SPACE

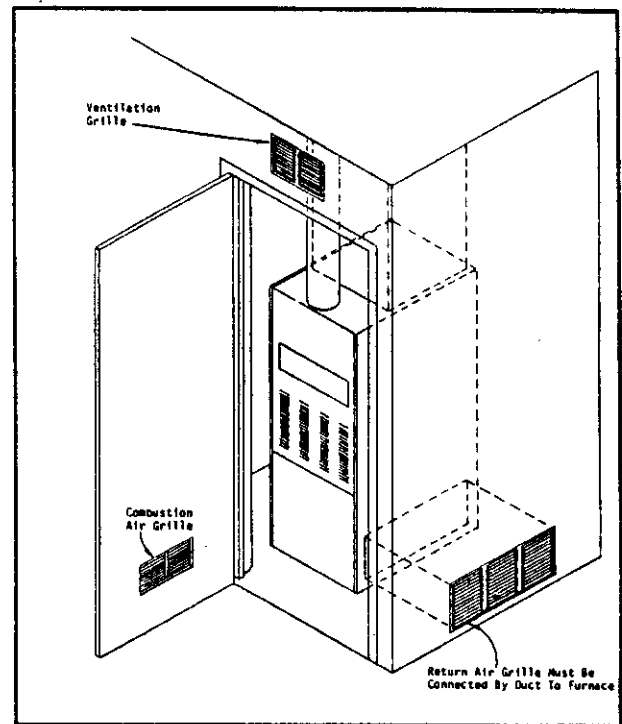

FIGURE 3 — FRESH AIR DUCT FOR TIGHTLY SEALED BUILDING

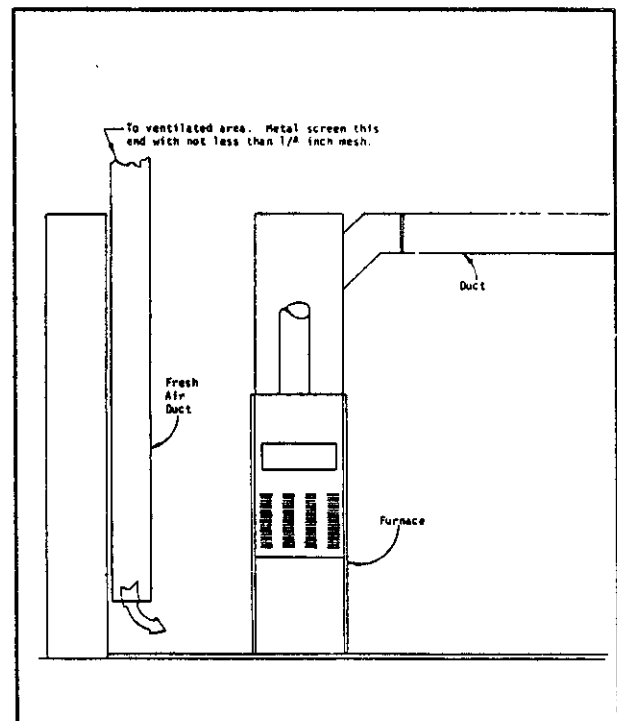

FIGURE 4 -- CHIMNEY OR VENT CAP INSTALLATION

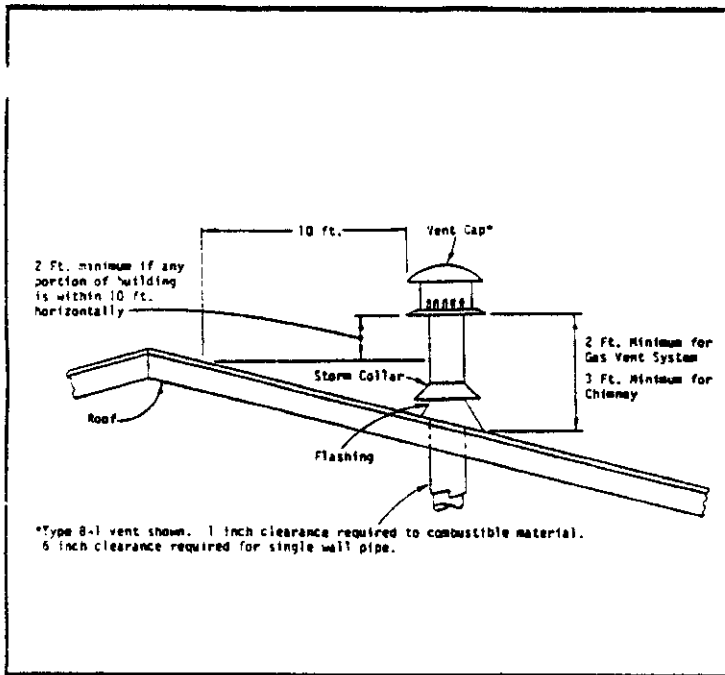

FIGURE 6 -- VENT THROUGH FLOOR

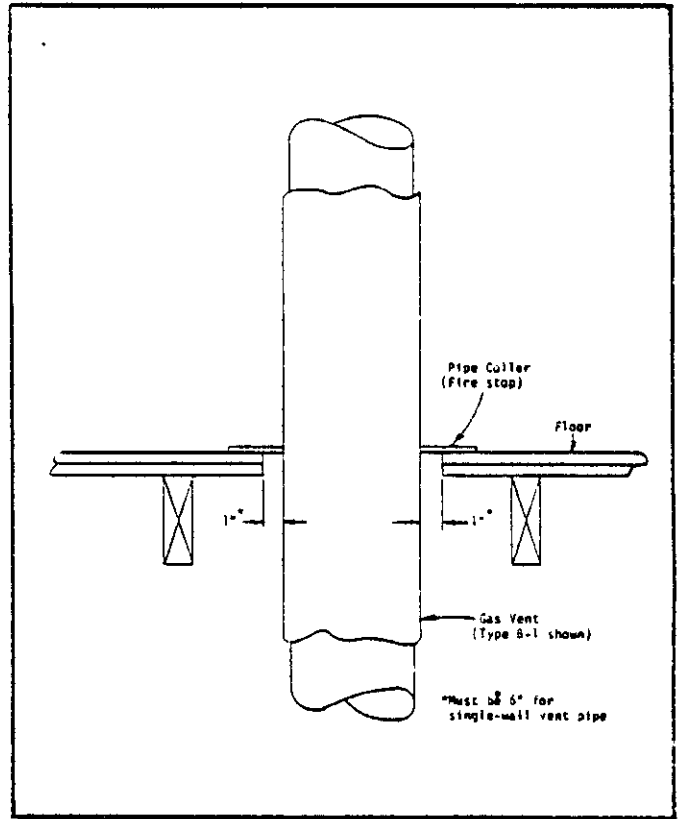

FIGURE 5 -- HORIZONTAL VENTING, COMBUSTIBLE WALL

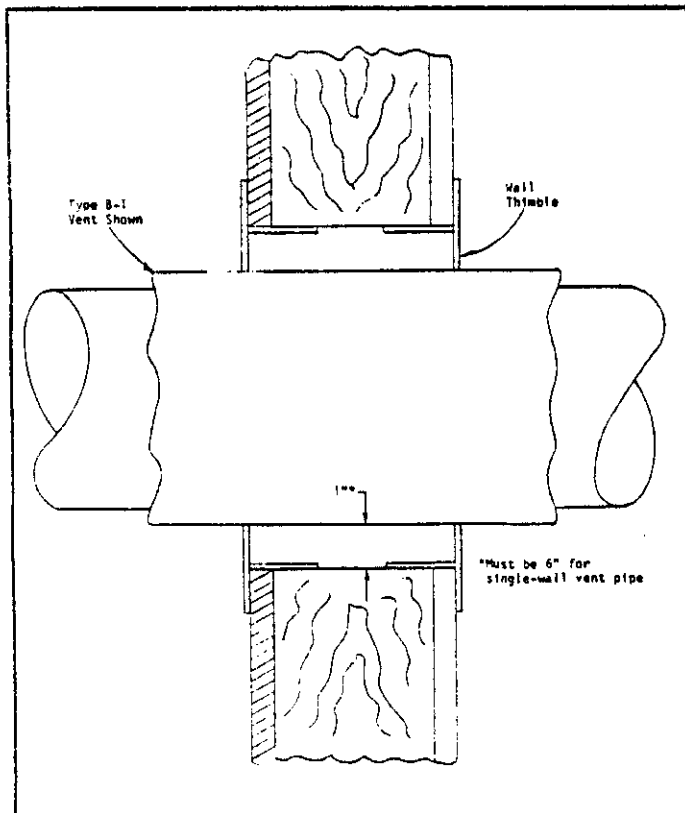
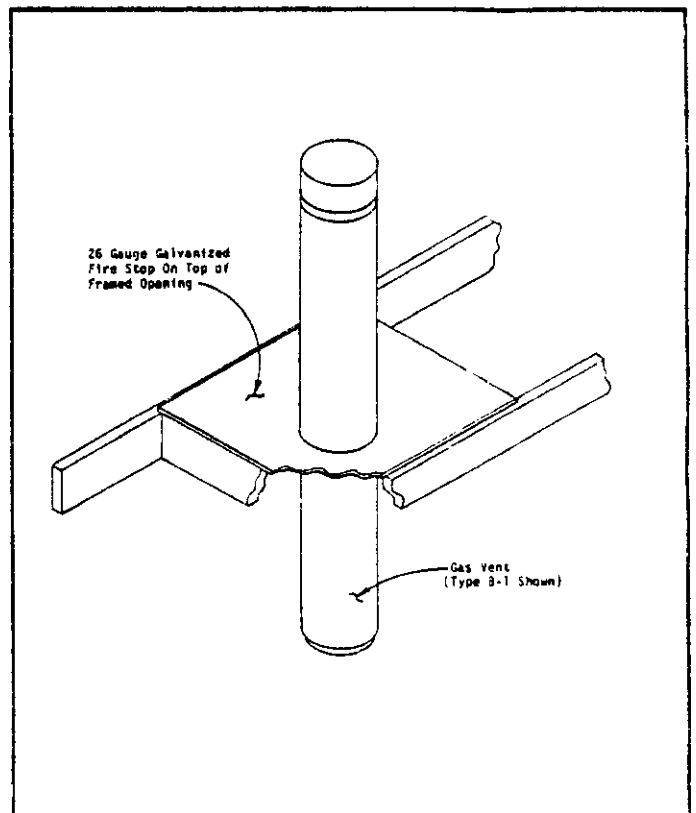

FIGURE 7 -- VENT THROUGH CEILING



VENTING CONNECTIONS

This furnace must be vented directly to the outside through a suitable chimney. This furnace as shipped from the factory is suitable for a dedicated flue only. It should not be vented and terminated horizontally through a side wall and is not suitable for use with plastic pipe. With the addition of optional field-installed Common Venting Kit, it is suitable to common vent this furnace along with another gas burning appliance to a single chimney for ease of installation. Refer to section on Common Venting beginning on pg. 16 of this instruction manual for complete details. The vent must be installed in compliance with the National Fuel Gas Code (ANSI Standard Z223.1-1984,) and these instructions.

GENERAL INSTRUCTIONS

1. The vent connector must be aluminum pipe and shall be the same size as the flue outlet on the furnace. Keep the vent as short and direct as possible. Type B-1 pipe is recommended.
2. Maintain a minimum clearance of 6" (1" for B-1) to any portion of the vent connector from any adjacent combustible materials. Single wall vent connector is permitted only within the same space (room or area) as the furnace. B-1 vent is required whenever the vent is enclosed or passes through floors, walls, ceilings, roofs or furred-out spaces. Joists, studs, floors, dry wall, paneling, sheathing, rafters, roofing and other materials classified as combustible must not be closer than 1" clearance to the B-1 vent.
3. If connected into masonry chimney, the vent pipe must be inserted into, but not beyond the inside wall of the chimney.
4. The gas vent must extend at least 2 feet above the highest point where it passes through the roof of a building (3 feet for a chimney) and at least 1 foot higher than any portion of a building within a horizontal distance of 10 feet. See Figure 4.
5. The vent pipe system shall be installed so as to avoid excessive turns which create unnecessary resistance to flow of vent gases.
6. Horizontal runs shall be as short and direct as possible. The maximum length of a single-wall vent pipe shall not exceed 75 percent of the height of the vent system. The maximum length of a Type B-1 double wall flue connection shall not exceed 100 percent of the height of the vent system.
7. All horizontal vent pipe shall be pitched upward from the furnace at least 1/4 inch per foot.
8. All vent systems shall be adequately supported to maintain proper clearances, to prevent physical damage, and to prevent separation to joints.
9. Vents passing through an exterior combustible wall must use a ventilated wall thimble. See Figure 5.
10. Vents passing through floors or ceilings must be fire-stopped. See Figure 6 and Figure 7.
11. Horizontal portions of the vent system shall be supported to prevent sagging. Pipe strap or equivalent means should be used every 3 to 5 feet depending upon pipe joint lengths.
12. A furnace shall not be connected to a chimney flue serving a separate appliance designed to burn solid fuel.

LENGTH OF STANDARD PIPE THREADS (inches)

PIPE SIZE	EFFECTIVE LENGTH OF THREAD	OVERALL LENGTH OF THREAD
3/8	3/8	9/16
1/2	1/2	3/4
3/4	1/2-9/16	13/16
1	9/16	1

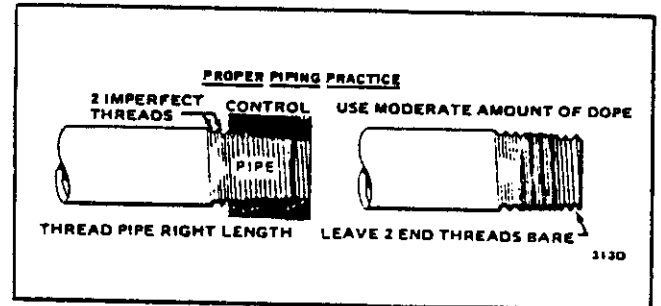
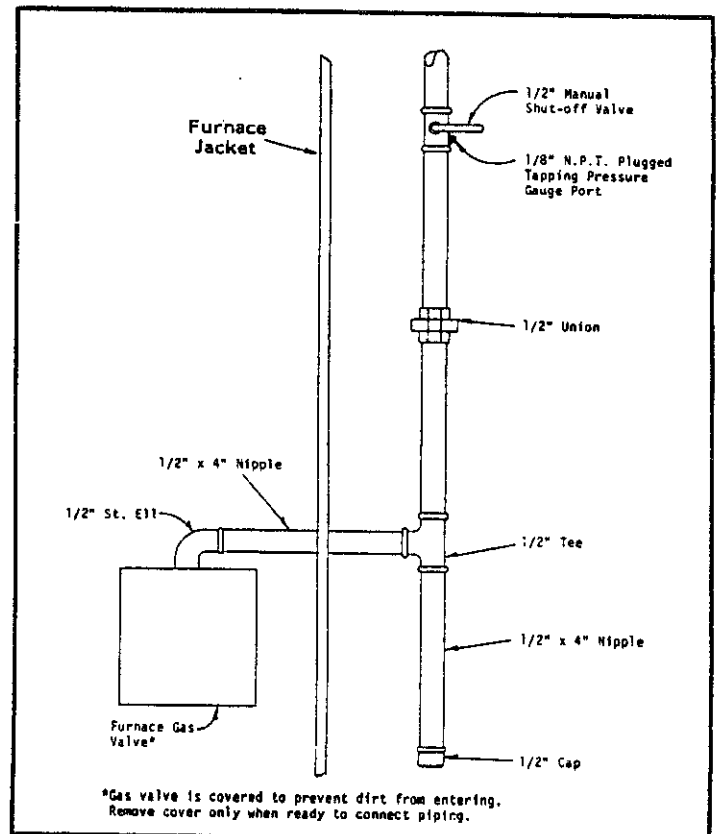

FIGURE 8 - GAS PIPE SIZES -- NATURAL GAS

Length of Pipe, Ft.	Pipe Capacity -- Btu Per Hour Input Pipe Size			
	1/2"	3/4"	1"	1-1/4"
10	132,000	278,000	520,000	1,050,000
20	92,000	190,000	350,000	730,000
30	73,000	152,000	285,000	590,000
40	63,000	130,000	245,000	500,000
50	56,000	115,000	215,000	440,000
60	50,000	105,000	195,000	400,000
70	46,000	96,000	180,000	370,000
80	43,000	90,000	170,000	350,000
100	38,000	79,000	150,000	305,000

FIGURE 9 - TYPICAL GAS PIPING



*Gas valve is covered to prevent dirt from entering. Remove cover only when ready to connect piping.

GAS SUPPLY AND PIPING

General Recommendations

1. Be sure the gas line complies with the local codes and ordinances, or in their absence with National Fuel Gas Code, ANSI Z223.1-1984.
2. A sediment trap or drip leg must be installed in the supply line to the furnace.
3. A ground joint union shall be installed in the gas line adjacent to and upstream from the gas valve and downstream from the manual main shut off valve.
4. A 1/8" N.P.T. plugged tapping accessible for test gauge connection shall be installed immediately upstream of the gas supply connection to the furnace for the purpose of determining the supply gas pressure.
5. A manual shut-off valve shall be installed in the supply gas line external to the furnace when required by local code. See Figure 9.
6. Use steel or wrought iron pipe and fittings.
7. DO NOT thread pipe too far. Valve distortion or malfunction may result from excess pipe within the control. Use pipe joint compound resistant to the action of liquified petroleum gases on male threads only. DO NOT use Teflon tape. See illustrations.
8. Refer to Figure 8 for Gas Pipe Sizes for natural gas. If more than one appliance is supplied from a single line size, capacity must equal or exceed the combined input to all appliances, and the branch lines feeding the individual appliances properly sized for each input.

CHECKING THE GAS PIPING

Before turning gas under pressure into piping, all openings from which gas can escape should be closed. Immediately after turning on gas, the system should be checked for leaks. This can be done by watching the 1/2 cubic foot test dial and allowing 5 minutes to show any movement, and by soaping each pipe connection and watching for bubbles. If a leak is found, make the necessary repairs immediately and repeat the above test. The furnace must be isolated from the gas supply piping system by closing the manual shutoff valve on the combination gas control valve during pressure testing of the gas supply piping system at pressures up to 1/2 psig. The furnace must be disconnected from supply piping and supply piping capped during any pressure testing of supply piping system at test pressures in excess of 1/2 psig.

Defective pipes or fittings should be replaced and not repaired. Never use a flame or fire in any form to locate gas leaks, use a soap solution.

After the piping and meter have been checked completely, purge the system of air. DO NOT bleed the air inside the furnace. Be sure to relight all the gas pilots on other appliances that may have been extinguished because of interrupted gas supply.

WIRING

CAUTION

For your personal safety, turn off electric power at service entrance panel before making any electrical connections.

All electrical work must conform with local codes and ordinances or, in their absence, with the National Electrical Code, ANSI/NFPA 70-1984.

ELECTRICAL POWER SUPPLY

Run a separate 120 volt, 15 ampere, 60 Hz, AC circuit from a separate fuse or circuit breaker in the service entrance panel. Locate a shut off switch at the furnace. Make connections from this switch to furnace junction box as shown in the furnace wiring diagram.

ELECTRICAL GROUNDING

A. RECOMMENDED GROUNDING METHOD

When installed, the furnace must be electrically grounded in accordance with local codes or in the absence of local codes, with the National Electrical Code, ANSI/NFPA No. 70-1984. Use a #14 AWC copper wire from green screw or green ground wire on the furnace to a grounded connection in the service panel or a properly driven and electrically grounded ground rod.

B. ALTERNATE GROUNDING METHOD

If the recommended grounding method is impossible, permanently ground the furnace from the ground connector to a grounded cold water pipe* using a separate, green colored, insulated conductor of appropriate size. THIS, HOWEVER, IS NOT RECOMMENDED.

*Cold water pipe must have metal continuity to electrical ground and not be interrupted by plastic, rubber or other electrically insulating connectors (including water meter or pump) without adding a jumper wire at these connections.

NOTE: DO NOT ground to a gas supply pipe. DO NOT connect to electric power supply until appliance is permanently grounded.

THERMOSTAT

Install the thermostat in accordance with instructions packed with it. Locate the thermostat 4-1/3 feet from the floor on an inside wall away from drafts, warm air registers and floor or table lamps. Refer to furnace wiring diagrams for connections.

All 24V wall thermostats have heat anticipators to compensate the thermostat for various system controls and allow the best possible cycle rates. Some anticipators are fixed and require no adjustment. However, the majority of wall thermostats have adjustable anticipators and do require adjustment to match the current rating of the gas valve. Most gas valves currently used are rated at .80 but check the rating of the valve on the furnace being installed to be sure.

Failure to adjust the anticipator lever to correspond to the actual current draw through the thermostat will cause severe short cycling if set too low and room temperature may never attain the thermostat set point, and if set too high, will cause room temperature to overshoot the set point.

NOTE: Optional demper does not change anticipator setting.

BLOWER OPERATION

All models are three or four speed direct drive and are equipped with a heating-cooling blower relay. When matched with the appropriate wall thermostat offers manual blower operation from the wall thermostat for air circulation.

CAUTION

After the furnace is operating with filters installed and all cabinet panels are in place, check the temperature rise through the unit to insure it is within the range specified on the furnace rating plate. If it is not, adjust blower speed until the temperature rise is within specified range.

FIELD INSTALLED EQUIPMENT

Wiring to be done in the field between the furnace and devices not attached to the furnace, or between separate devices which are field installed and located, shall conform with the temperature limitation for Type T wire [63°F rise (36°C)] when installed in accordance with the manufacturer's instructions. Refer to wiring diagrams, pages 12 thru 14.

FILTERS

All models are shipped with filters. See Figure 10 for sizes. Hi-Boy models have the filters in their intended positions. Hi-Boy models are shipped with filter on the left side. They can alternately be located on right side or bottom. See following information. The counterflow models require a bracket installation and final filter location projects into return air plenum attachment to furnace, see Figures 11 and 12. Refer to Figures 13 and 14 for Lo-Boy models.

FIGURE 10

FILTER SIZES FOR GAS FURNACES		
Model	Size	
86,000 Lo-Boy	(1) 18-3/4 x 20	P
115,000 Lo-Boy	(1) 22-3/4 x 20	P
145,000 Lo-Boy	(2) 13 x 20	P
All Hi-Boys	(1) 16 x 25	P
60,000 Counterflow	(1) 15 x 20	P
86,000 Counterflow	(2) 10 x 20	P
115,000 Counterflow	(1) 15 x 20 (1) 10 x 20	P

P = Permanent

FILTER LOCATIONS--REMOVAL AND REPLACEMENT PROCEDURES - ALL HI-BOY FURNACES

To remove filters from ALL sectional Hi-Boys, first remove the upper burner door and then the lower blower compartment door by grasping top of door and pull up and away from the furnace. Then, remove the "S" clip and spring by pulling the clip towards the front of the furnace.

For right hand side filter location, relocate filter and retaining spring assembly to right side filter brackets.

For right hand side filter location on the 60,000 model furnaces, the optional filter rack is required because there is no room between the blower motor and right side of furnace to remove or install filter.

The filter may now be removed simply by pulling it towards the center of the furnace and outward.

The location may vary, depending on which side the installer located the return air duct.

This filter is the permanent high velocity type foam filter which may be washed and used over and over. DO NOT replace it with a fiberglass filter of the same size.

To replace filter, reverse the above process.

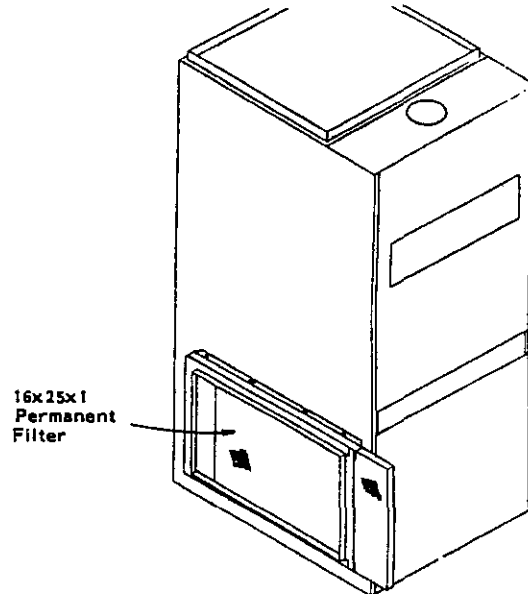

16x25x1
Permanent
Filter

To remove filter from the optional external filter rack, grasp the exposed end of the filter and pull from the filter rack.

The location may vary, depending on which side the installer located the return air duct.

This filter is the permanent high velocity type foam filter which may be washed and used over and over. DO NOT replace it with a fiberglass filter of the same size.

To replace filter, reverse the above process.

ALTERNATE BOTTOM FILTER LOCATION

All Hi-Boy models have a removeable panel on the base for a bottom return air installation.

To utilize this feature, remove the fill plate by bending the four tabs up 90°. Relocate filter retainer spring from side to bottom brackets. Leave the four tabs bent in the upright position as they will now serve to keep the filter positioned left to right.

On the 60,000 model the standard 16x25x1 filter must be cut down to 12x25x1. See illustration below.

Cut along top of rib with metal shears. Remove top 4 inches.

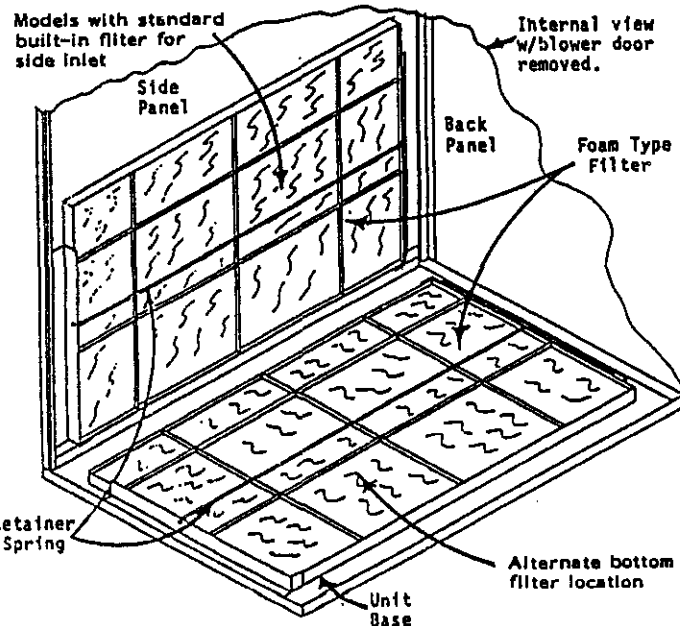
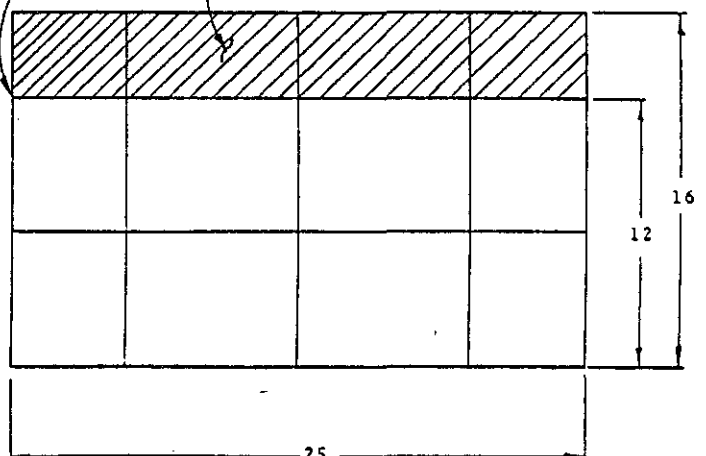

Models with standard built-in filter for side inlet

Internal view w/blower door removed.

Retainer Spring

Alternate bottom filter location

FILTER LOCATIONS -- COUNTERFLOW MODELS

Counterflow models normally have filters installed in the return air plenum above the furnace unless a common return air/filter grille is used.

The electrical switch should be turned "off" before the front door to furnace is removed. After removing the front door, remove the left side filter door in the upper section of the furnace. Refer to the illustrations below for proper filter locations.

FILTER LOCATIONS -- LO-BOY MODELS

Lo-Boy models have the filters installed in the return air cabinet section of the furnace. They are accessible from the rear of the furnace by removing the blower/filter access door. The electrical switch should be turned "off" prior to removing the access door.

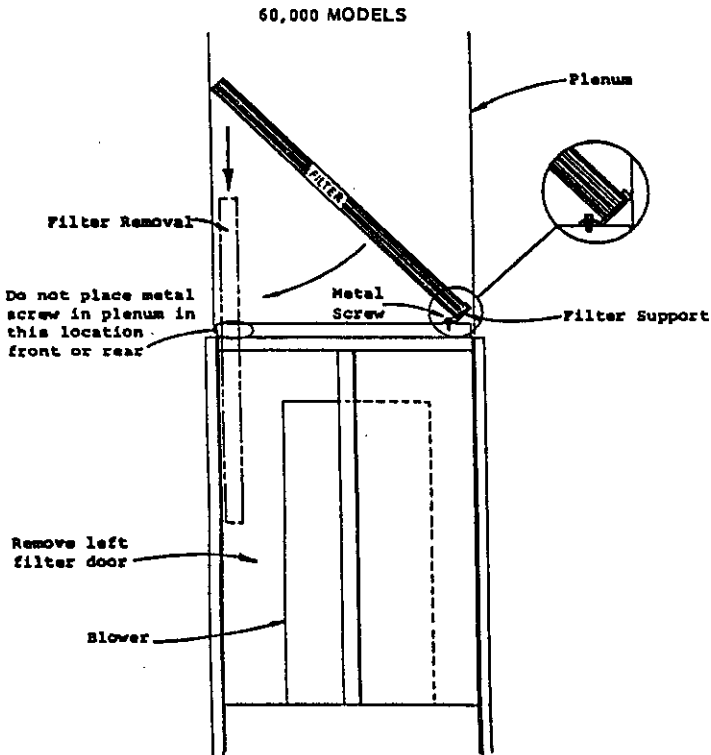

Attach filter support to furnace as shown with two sheet metal screws. The filter can be installed and removed through the left filter door.

FIGURE 11

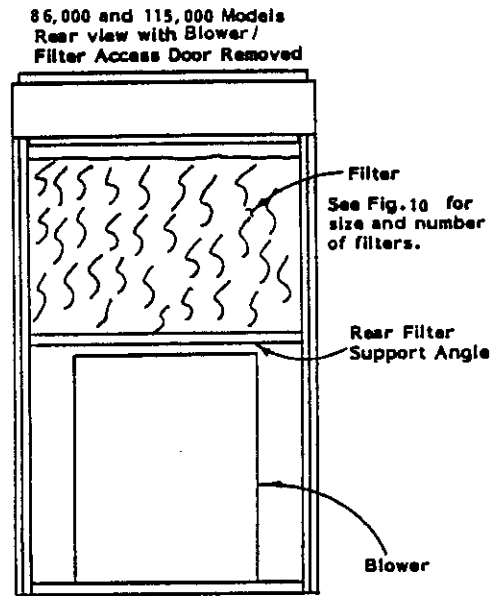

FIGURE 13.

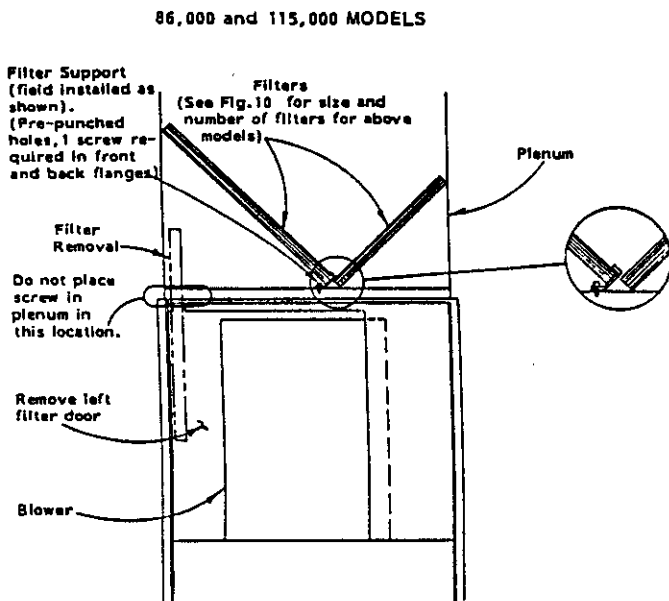

FIGURE 12.

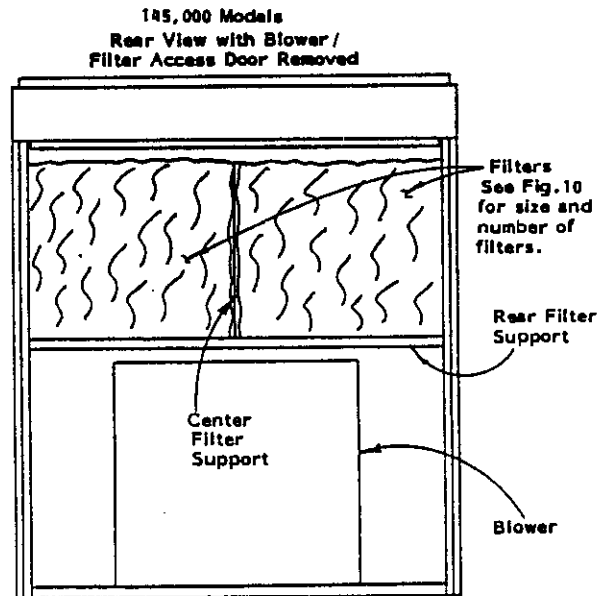

FIGURE 14.

SEQUENCE OF OPERATION

On a call for heat from the thermostat the DPST relay coil is energized through the normally closed contact of the air proving pressure switch. When the relay coil is energized, the relay contacts close which simultaneously energizes the induced draft blower and locks in the relay coil. Once sufficient draft is established, the ignition module will be energized through the normally open contact of the pressure switch. The pilot ignition electrode will begin to spark and pilot valve will be energized allowing pilot gas flow. Upon establishment of pilot burner flame, adequate flame for burner ignition is proved to control module at which point main gas valve is energized and spark is discontinued.

MAINTENANCE INSTRUCTIONS

The furnace and its vent system should be inspected annually by a qualified service agency, generally prior to the heating season.

NOTE: PRIOR TO THE START OF ANY OF THE FOLLOWING MAINTENANCE PROCEDURES SHUT OFF ALL POWER TO THE UNIT.

Routine maintenance procedures are the responsibility of the owner and are contained in the Owner's Manual. These are briefly outlined below:

1. **Air Filters.** Check the condition on at least a monthly basis when the furnace is in use or replace whenever it is necessary.
2. **Lubrication Requirements.** Direct drive motors are permanently lubricated, no maintenance required. The induced draft blower motor should be oiled every six months with SAE20 motor oil.
3. **Check Temperature Rise.** Adjust blower speed if necessary to obtain a temperature rise within the range specified on the furnace rating plate.
4. **Basic Examination of Furnace.** Visual inspection of pilot flame and the main burners. Also inspection of the burner compartment and the vent system for sooting and scaling.
5. **Periodic Inspection of the Vent System.** Visual inspection of the vent system from the furnace to the chimney for any leaking or defective parts.

REPLACEMENT PARTS

Replacement parts for the gas furnaces are available through local distributor.

Parts list covering all of the normally serviceable items are shown on page 9. When ordering parts or making inquiries pertaining to any of the furnaces covered by these instructions, it is very important to always supply the COMPLETE model number and serial number of the furnace. This is necessary to assure that the correct parts (or an approved alternate part) are issued to the service agency.

SERVICE AGENCY PROCEDURES

1. The intermittent pilot lights only when the thermostat calls for heat and the main burner lights within a few seconds thereafter. It is recommended that any observation of pilot or main burner operation be done only with the burner compartment door in place and viewing through the combustion air slots.

The pilot flame can be adjusted by removing the pilot adjustment cover screw. Turn inner adjustment screw clockwise to decrease and counterclockwise to increase pilot flame. Be sure to replace cover screw after adjustment to prevent possible gas leakage.

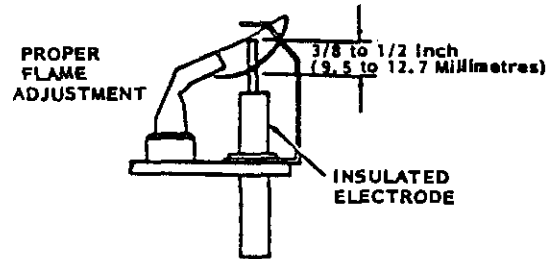

INTERMITTENT PILOT

2. Observe the main burners in operation, viewing through the combustion air slots. The flame should be mostly "blue" with possibly a little orange (not yellow) at the tips of the flames. The flames should be in the center of the heat exchanger compartments and not impinging on the heat exchanger surfaces themselves.

Observe the fire until the blower starts (there is a normal delay period until the heat exchanger warms up). There should be no change in the size or shape of the flame. If there is any wavering or blowing of the flame on blower start-up, it is an indication of a possible leak in the heat exchanger.

The air shutters are factory adjusted completely open. If flashback occurs, the air shutters may be closed slightly to prevent the flashback.

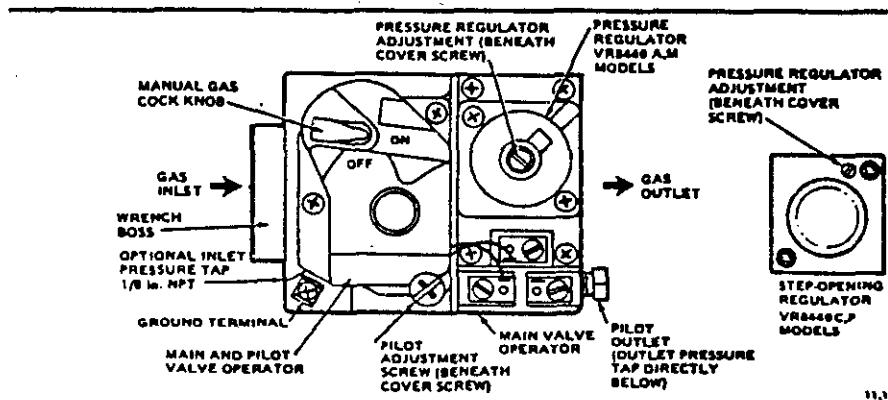

TOP VIEW OF VR8440 GAS CONTROL

PARTS LIST

High Economy Hi-Boy Gas Furnace

9-87

PART NO.	DESCRIPTION	60,000	86,000	115,000
8552-002	Capacitor 5/370V	X	X	
8552-004	Capacitor 7.5/370V			X
8402-042	Fan and Limit. 11"	X	X	X
7003-004	Filter 16x25 P	X	X	X
171-101	Heat Exchanger	X		
171-104	Heat Exchanger		X	
171-107	Heat Exchanger			X
*	Housing - Blower 10-7	X		
*	Housing - Blower 10-9		X	
*	Housing - Blower 10-10			X
8109-001	Combustion air blower	X	X	X
8600-002	Ignition Wire	X	X	X
5651-060	Ignition Module	X	X	X
163-001	Manifold Assembly	X		
163-002	Manifold Assembly		X	
163-003	Manifold Assembly			X
8105-008	Motor 1/3 hp	X		
8105-009	Motor 1/3 hp		X	
8106-018	Motor 1/2 hp			X
8200-003	Motor Mount	X	X	
5451-011	Motor Mounting Parts	X	X	X
9010-010	Orifice - Nat	X	X	X
8406-013	Micro Switch	X	X	X
8554-009	Pilot Burner - Nat	X	X	X
8406-021	Pressure Switch	X	X	X
8201-048	Relay - DPST	X	X	X
8201-006	Transformer w/2-Speed Relay	X	X	X
5651-062	Valve - Nat. 1/2 x 3/4	X	X	X
9010-015	Venturi - 2 Cell	X		
9010-016	Venturi - 3 Cell		X	
9010-017	Venturi - 4 Cell			X
5152-010	Wheel - Blower DD10-7A	X		
5152-014	Wheel - Blower DD10-9A		X	
5152-015	Wheel - Blower DD10-10A			X
8200-028	Motor Mount			X
4046-104	Wiring Diagram	X	X	X

*Please order by model number.

Supersedes all previous lists.

Subject to change without notice.

PARTS LIST

High Economy Counterflow Gas Furnace

9-87

PART NO.	DESCRIPTION	60,000	86,000	115,000
8552-002	Capacitor 5/370V	x	x	
8552-004	Capacitor 7.5/370V			x
8402-046	Fan and Limit 11"	x		
8402-045	Fan and Limit 8"		x	x
7003-001	Filter 10x20 P		(2)	x
7003-003	Filter 15x20 P	x		x
171-123	Heat Exchanger	x		
171-124	Heat Exchanger		x	
171-125	Heat Exchanger			x
*	Housing - Blower 10-7	x		
*	Housing - Blower 10-9		x	
*	Housing - Blower 10-10			x
8600-002	Ignition Wire	x	x	x
8109-001	Combustion air blower	x	x	x
8402-014	Limit Switch 140°	x	x	x
163-001	Manifold Assembly	x		
163-002	Manifold Assembly		x	
163-003	Manifold Assembly			x
8406-013	Micro Switch	x	x	x
8105-009	Motor 1/3 hp		x	
8105-008	Motor 1/3 hp	x		
8106-018	Motor 1/2 hp			x
8200-003	Motor Mount	x	x	
5451-011	Motor Mounting Parts	x	x	x
5651-060	Ignition Module	x	x	x
9010-010	Orifice - Nat	x	x	x
8554-009	Pilot and Orifice - Nat	x	x	x
8406-021	Pressure Switch	x	x	x
8201-048	Relay - DPST	x	x	x
8201-005	Fan Relay w/Trans.	x	x	x
8200-028	Motor Mount			x
5651-062	Valve - Nat. 1/2 x 3/4	x	x	x
9010-015	Venturi 2-Cell	x		
9010-016	Venturi 3 Cell		x	
9010-017	Venturi 4-Cell			x
5152-014	Wheel DD10-9A (blower)		x	
5152-015	Wheel DD10-10A (blower)			x
5152-010	Wheel DD10-7A (blower)	x		
4046-105	Wiring Diagram	x	x	x

*Please order by model number.
 Supersedes all previous lists.
 Subject to change without notice.

PARTS LIST

High Economy Lo-Boy Gas Furnace

9-87

Part No.	Description	86,000	115,000	145,000
8552-002	Capacitor 5/370V	x		
8552-004	Capacitor 7.5/370V		x	
8552-026	Capacitor 15/370V			x
8402-043	Fan and Limit 8"	x	x	
8402-042	Fan and Limit 11"			x
7003-014	Filter - 18-3/4 x 20 P	x	x	
7003-015	Filter - 22-3/4 x 20 P			x
7003-016	Filter - 13 x 20 P			x
171-128	Heat Exchanger	x		
171-127	Heat Exchanger		x	
171-126	Heat Exchanger			x
*	Housing - Blower 10-9	x		
*	Housing - Blower 10-10		x	
8600-002	Ignition Wire	x	x	x
8109-001	Combustion air blower	x	x	x
8200-028	Motor Mount		x	
163-002	Manifold Assembly	x		
163-003	Manifold Assembly		x	
163-004	Manifold Assembly			x
8406-013	Micro Switch	x	x	x
8105-009	Motor 1/3 hp	x		
8106-018	Motor 1/2 hp		x	
8107-004	Motor 3/4 hp			x
8200-003	Motor Mount	x		
8200-026	Motor Mount			x
5451-011	Motor Mounting Parts	x	x	
9010-010	Orifice - Nat	x	x	x
8554-009	Pilot and Orifice - Nat	x	x	x
5651-060	Ignition Module	x	x	x
8406-021	Pressure Switch	x	x	x
8201-048	Relay - DPST	x	x	x
8201-006	Fan Relay w/Trans.	x	x	x
5651-062	Valve - Nat. 1/2 x 3/4	x	x	
5651-023	Valve - Nat. 1/2 x 3/4			x
9010-016	Venturi 3 Cell	x		
9010-017	Venturi 4 Cell		x	
9010-018	Venturi 5 Cell			x
5152-014	Wheel DD10-9A (blower)	x		
5152-015	Wheel DD10-10A (blower)		x	
5152-050	Wheel and Housing Assembly			x
4046-107	Wiring Diagram	x	x	x

Supersedes all previous lists.
Subject to change without notice.

*Please order by model number.

CONNECTION DIAGRAM

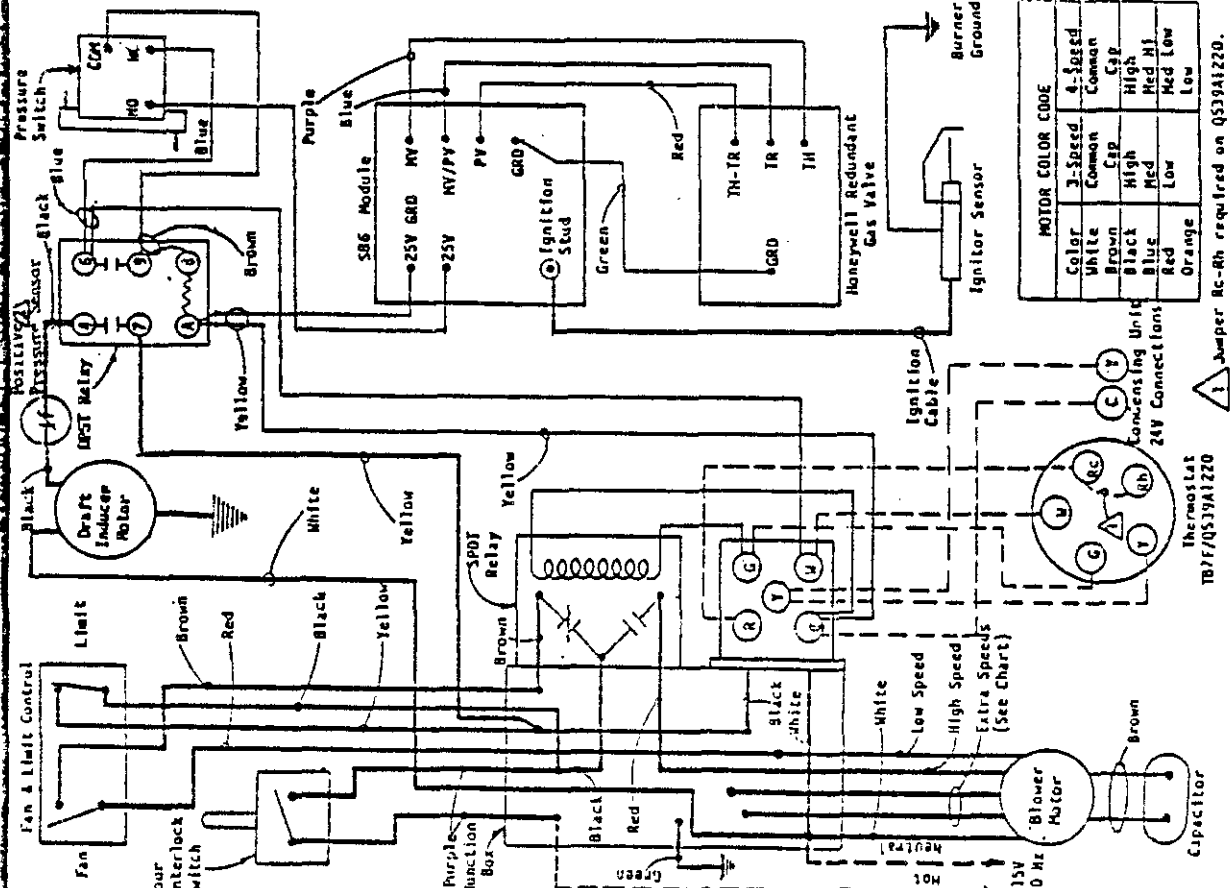

LADDER DIAGRAM

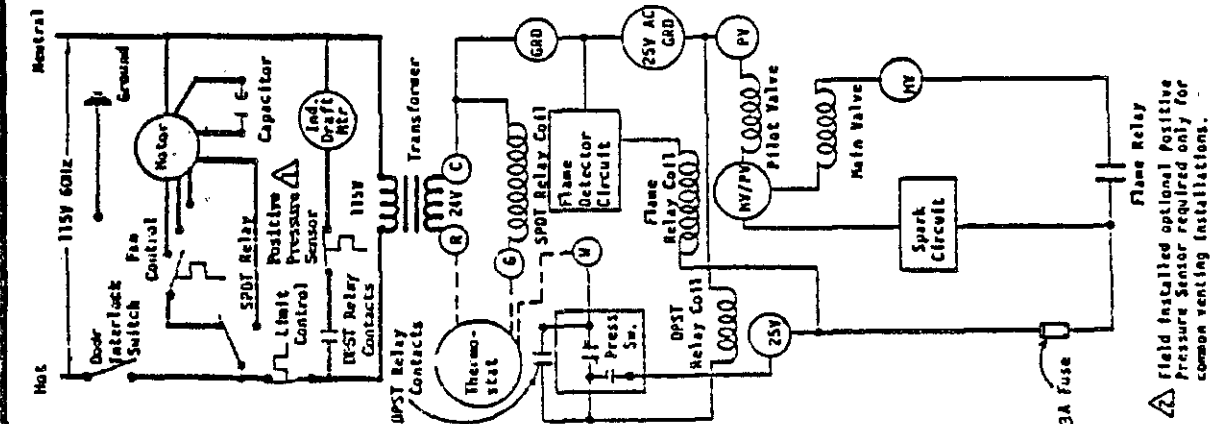

S86 MODULE NORMAL SEQUENCE OF OPERATION

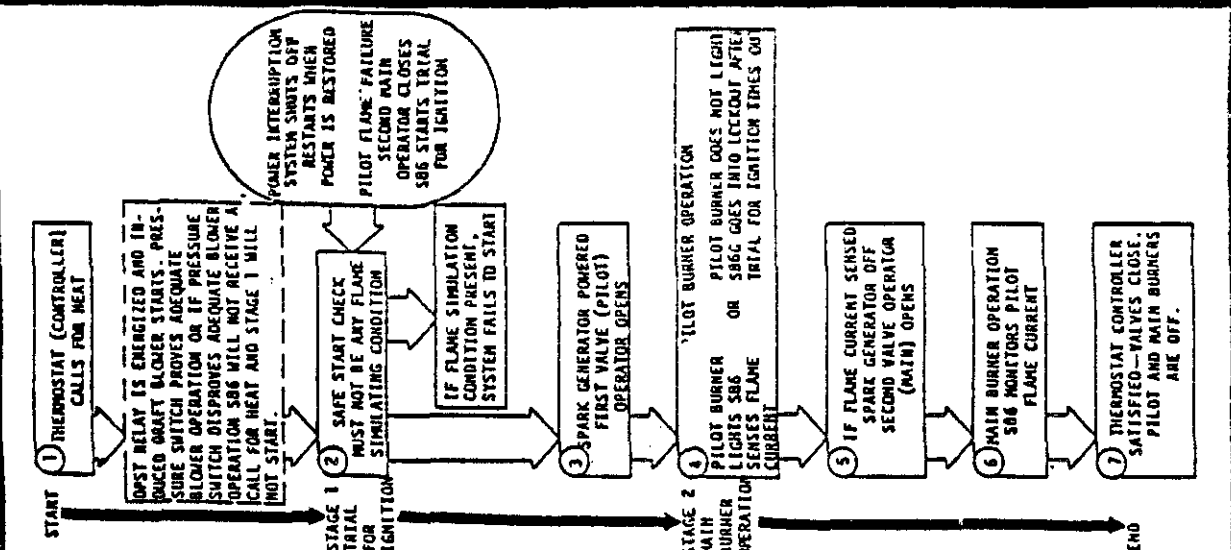

HIGH ECONOMY HI-BOY MODELS 4046-104F
 WIRING DIAGRAM

S86 MODULE NORMAL SEQUENCE OF OPERATION

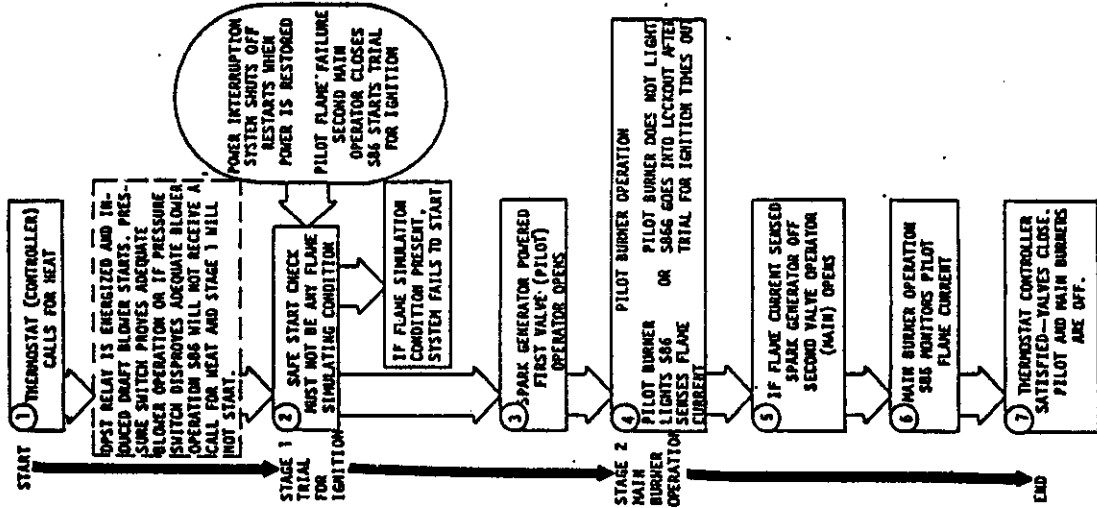

LADDER DIAGRAM

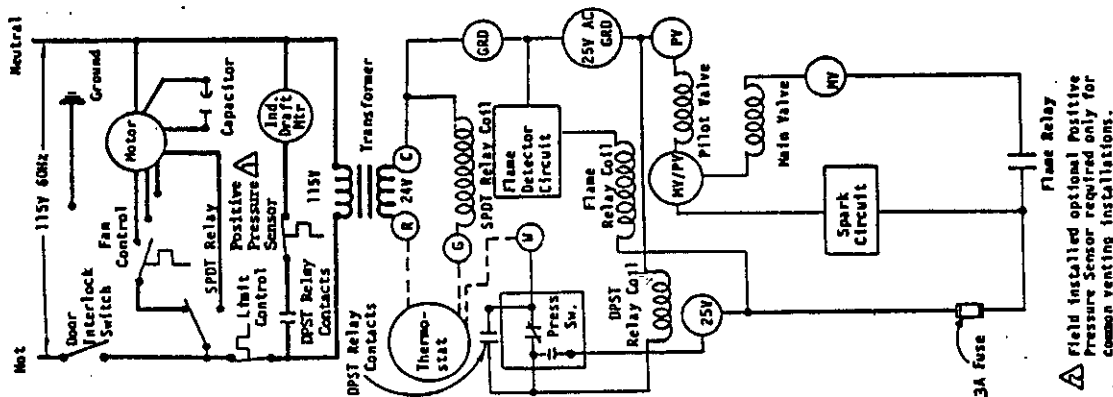

FACTORY WIRING FIELD WIRING
Low Voltage High Voltage

CONNECTION DIAGRAM DISCONNECT POWER BEFORE SERVICING.

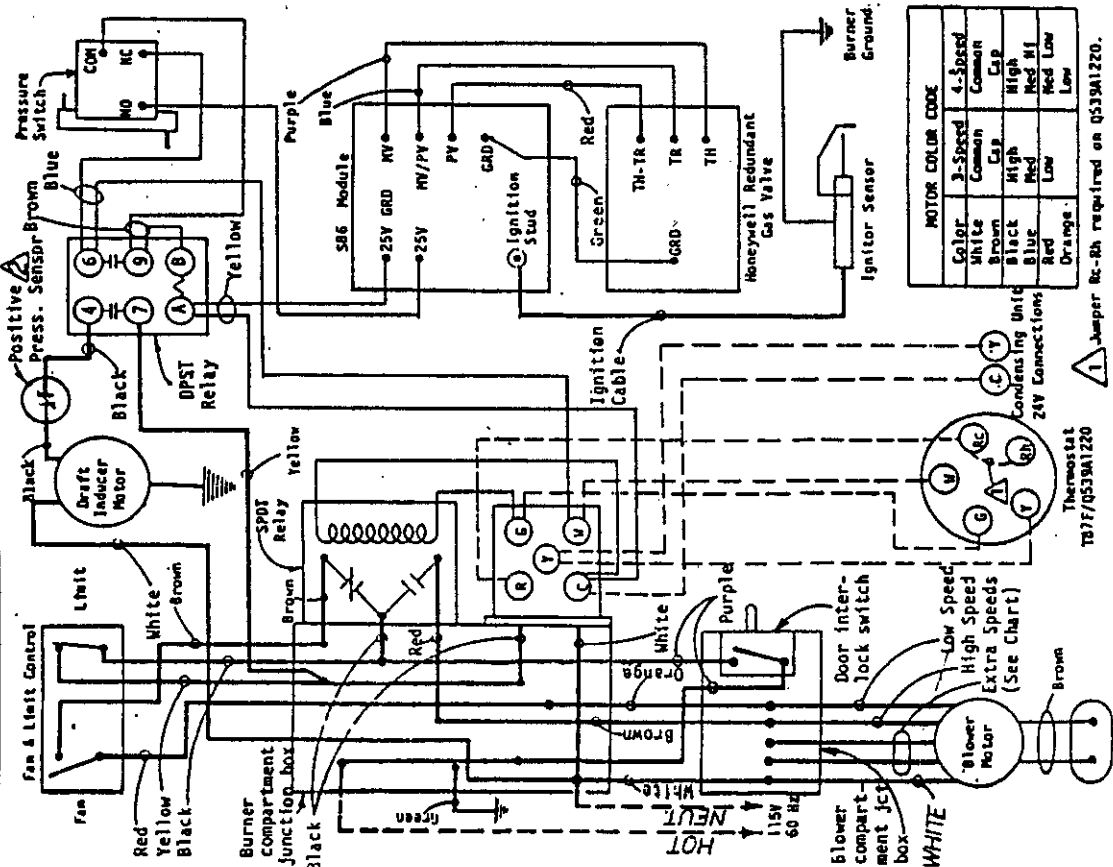

IF ANY OF THE ORIGINAL WIRE AS SUPPLIED WITH THE APPLIANCE MUST BE REPLACED, IT MUST BE REPLACED WITH WIRING MATERIAL HAVING A TEMPERATURE RATING OF AT LEAST 105°C., EXCEPT THE IGNITION CABLE WHICH IS 250°C. HIGH VOLTAGE CABLE.

CONNECTION DIAGRAM

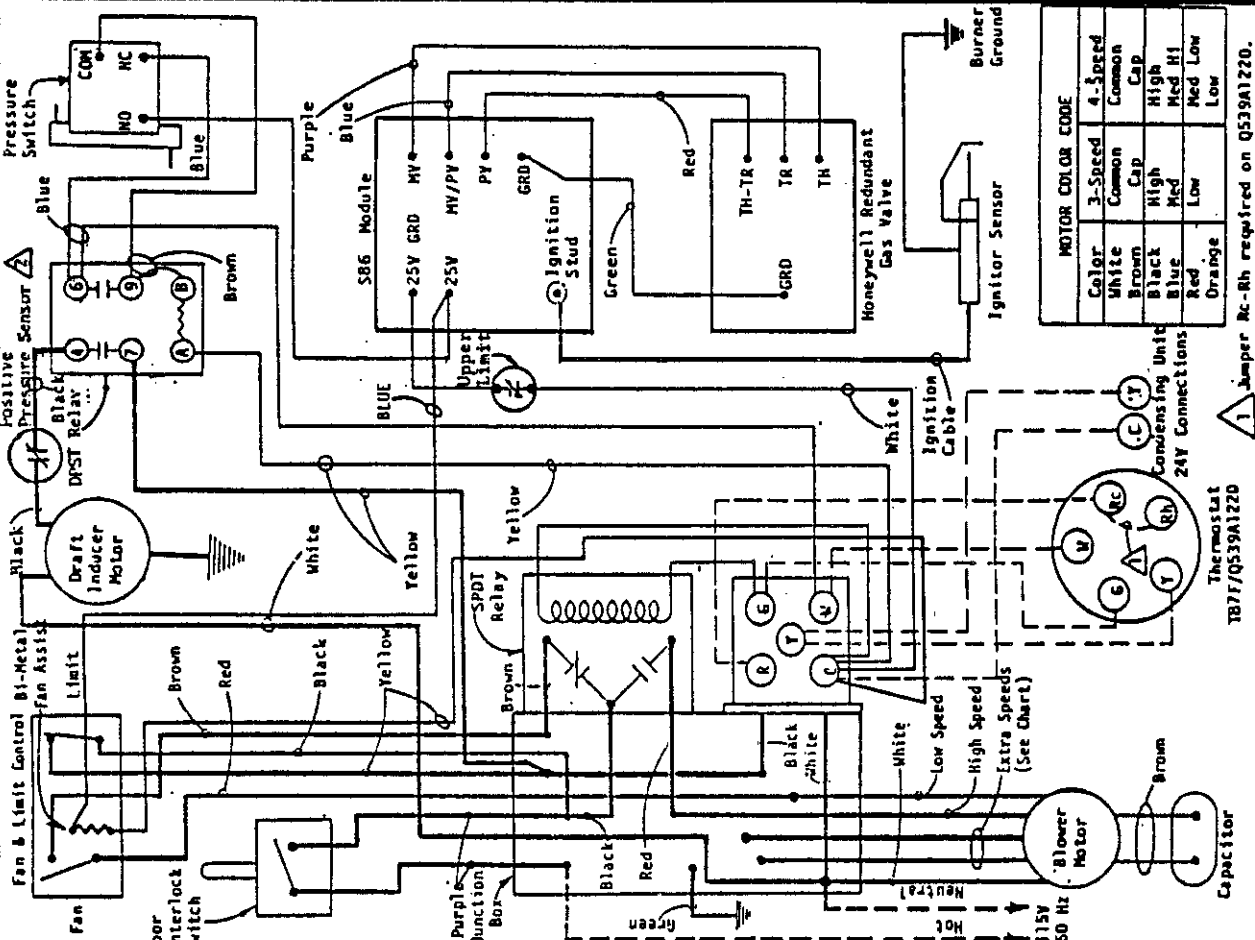

IF ANY OF THE ORIGINAL WIRE AS SUPPLIED WITH THE APPLIANCE MUST BE REPLACED, IT MUST BE REPLACED WITH WIRING MATERIAL HAVING A TEMPERATURE RATING OF AT LEAST 105°C. EXCEPT THE IGNITION CABLE WHICH IS 250°C. HIGH VOLTAGE CABLE.

LADDER DIAGRAM

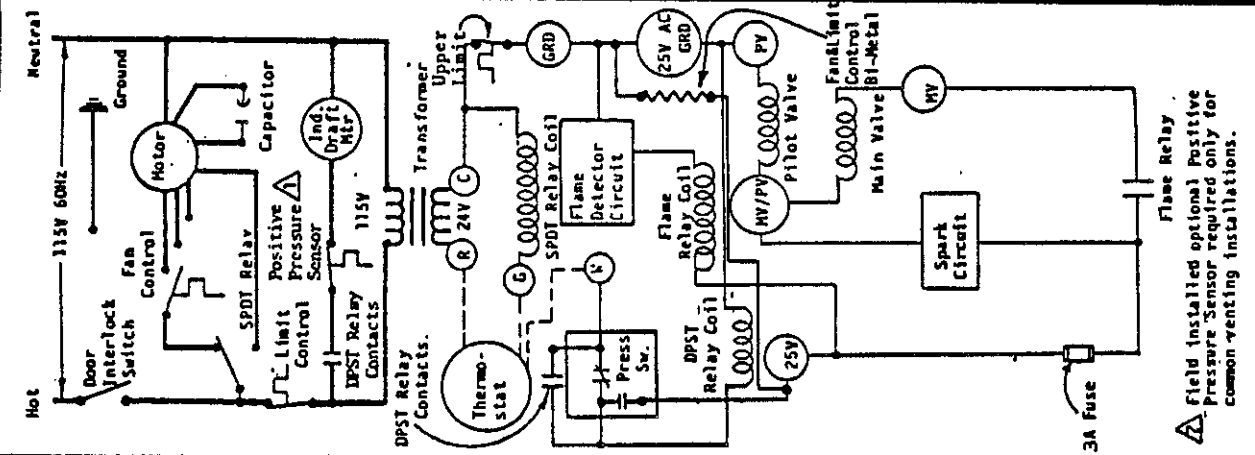

FACTORY WIRING
 Low Voltage
 High Voltage
 FIELD WIRING

S86 MODULE NORMAL SEQUENCE OF OPERATION

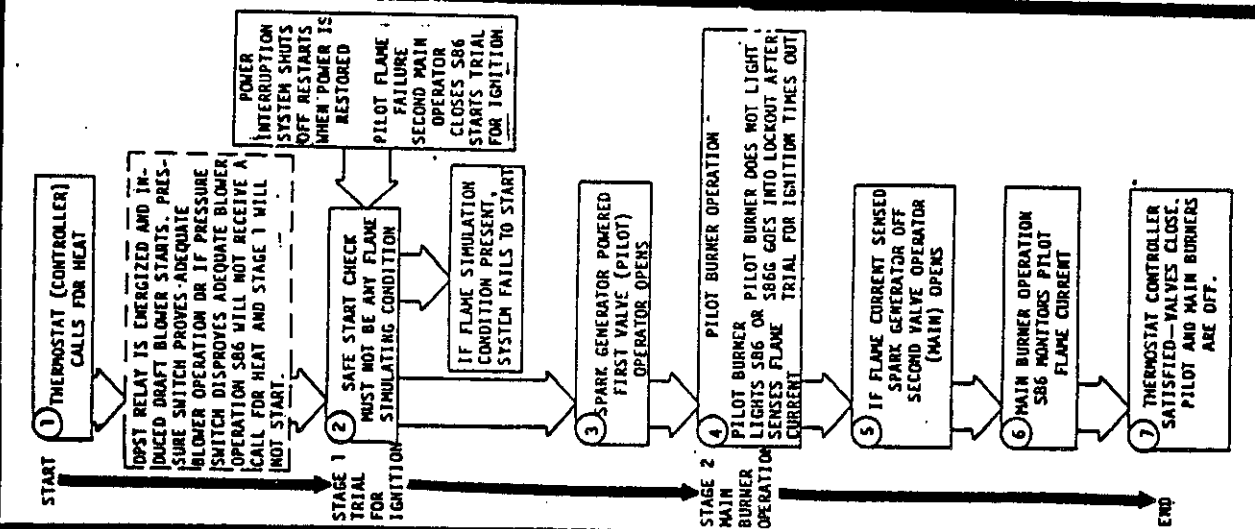

HIGH ECONOMY COUNTERFLOW MODELS
 WIRING DIAGRAM 4046-105

S86 INTERMITTENT PILOT SYSTEM TROUBLESHOOTING

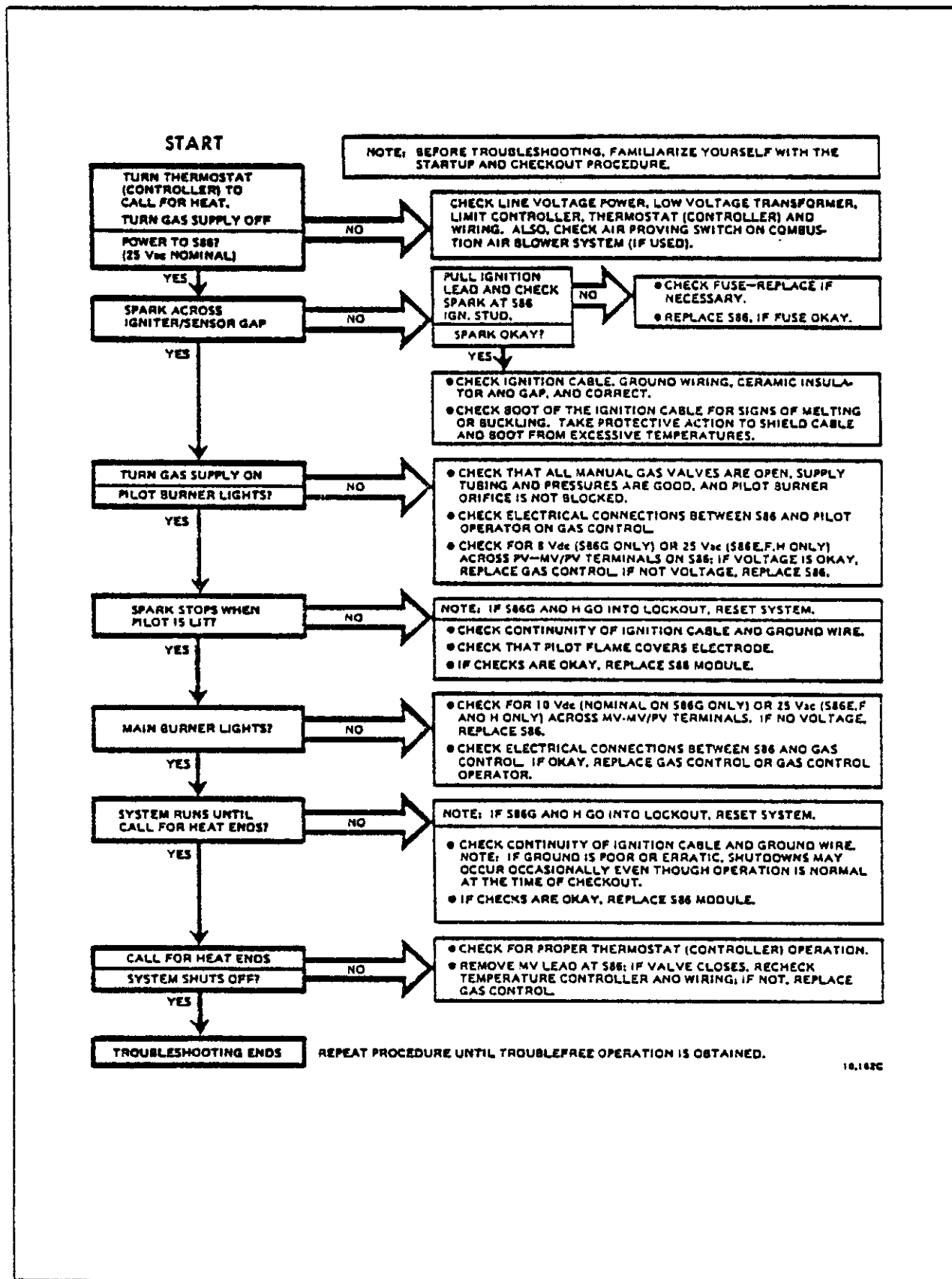

10-162C

COMMON VENTING REQUIREMENTS

For common venting this furnace with another gas burning appliance, the addition of a Common Venting Kit is required. This kit is field installed by the installing contractor following the instructions packaged with the kit. It is a very simple procedure requiring only the removal and reinsertion of two screws and the reconnection of one wire. The kits that are required are detailed below:

Furnace Model	Input Rating Btu/Hour	Common Venting Kit No.
IH60D36A,B,C IH85D48A,B,C IH115D48A,B,C	58,000 86,000 115,000	8620-005 8620-006 8620-006
IC60D36A,C IC85D42A,C IC115D48A,C	58,000 86,000 115,000	8620-011 8620-011 8620-011
IL85D42A,C IL115D48A,C IL145D60A,C	86,000 115,000 145,000	8620-006 8620-006 8620-005

There are some minimum specifications that apply to the common venting system design. These are outlined below with additional reference made to the illustrations as shown:

Furnace Model	Minimum Total Vent Height "H"	Furnace Vent Connector Size	Minimum Common Vent Pipe Connector	
			3" Water Heater	4" Water Heater
IH60D36A,B,C IH85D48A,B,C IH115D48A,B,C	8' 8' 8'	3" 3" 4"	4" 4" 5"	4" 4" 5"
IC60D36A,C IC85D42A,C IC115D48A,C	8' 8' 8'	3" 4" 4"	4" 4" 5"	4" 4" 5"
IL85D42A,C IL115D48A,C IL145D60A,C	8' 8' 8'	3" 4" 4"	4" 5" 5"	4" 5" 5"

See the following Figure illustrations for common venting arrangements:

Furnace Model	Vented With 3" Water Heater	Vented With 4" Water Heater
IH60D36A,B,C IH85D48A,B,C IH115D48A,B,C	Fig. 15, 16 Fig. 15, 16 Fig. 19, 20	Fig. 17, 18 Fig. 17, 18 Fig. 19, 20
IC60D36A,C IC85D42A,C IC115D48A,C	Fig. 15, 16 Fig. 15, 16 Fig. 16, 17	Fig. 17, 18 Fig. 17, 18 Fig. 19, 20
IL85D42A,C IL115D48A,C IL145D60A,C	Fig. 15, 16 Fig. 19, 20 Fig. 19, 20	Fig. 17, 18 Fig. 19, 20 Fig. 19, 20

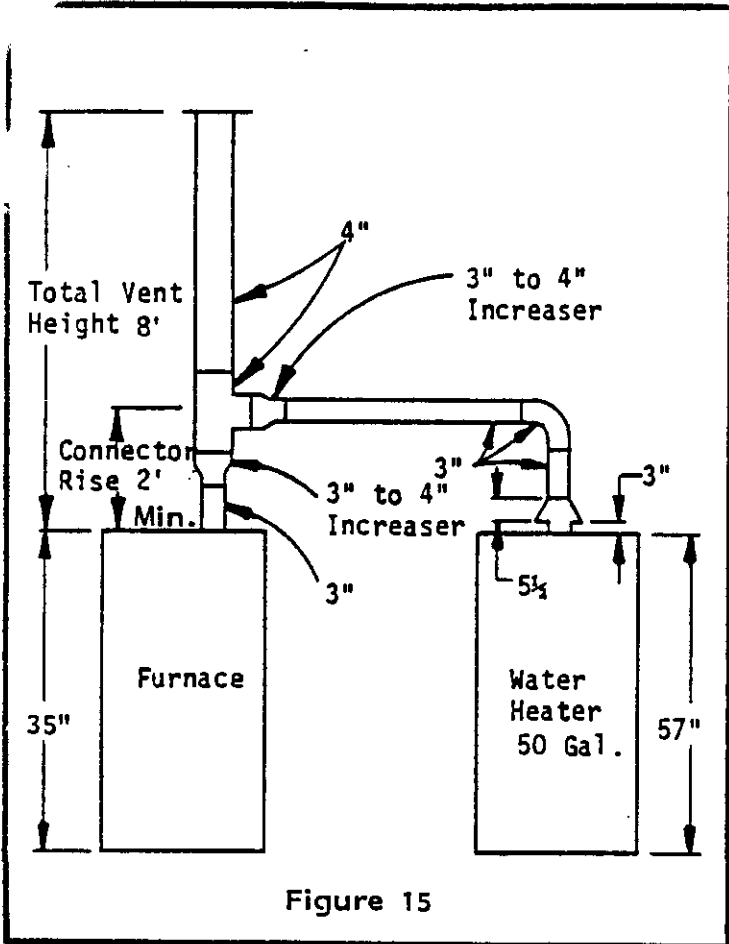

Figure 15

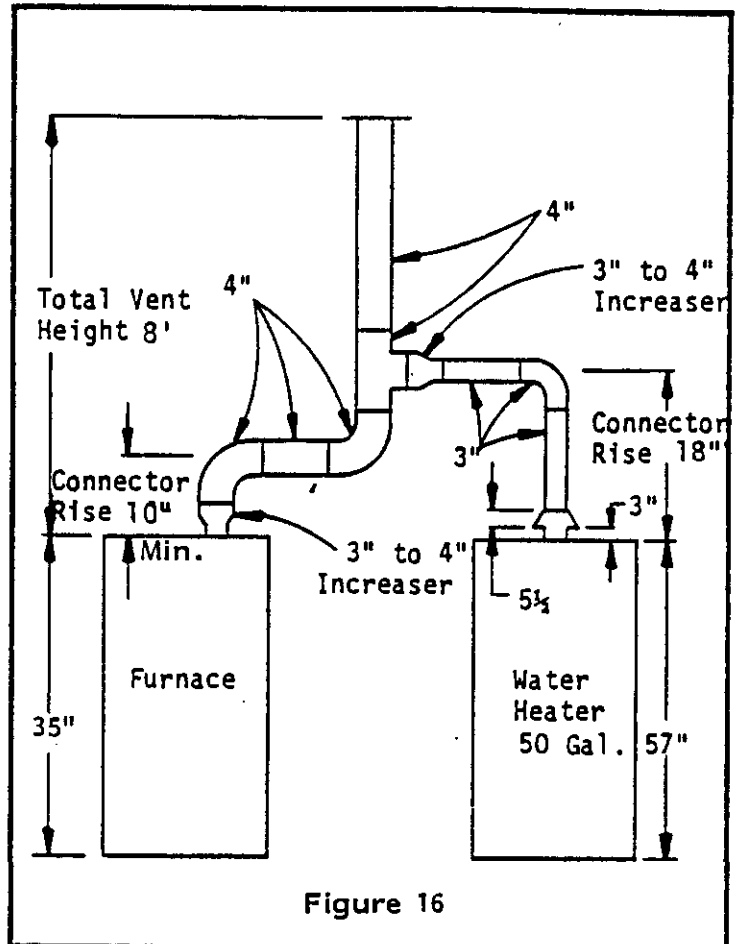

Figure 16

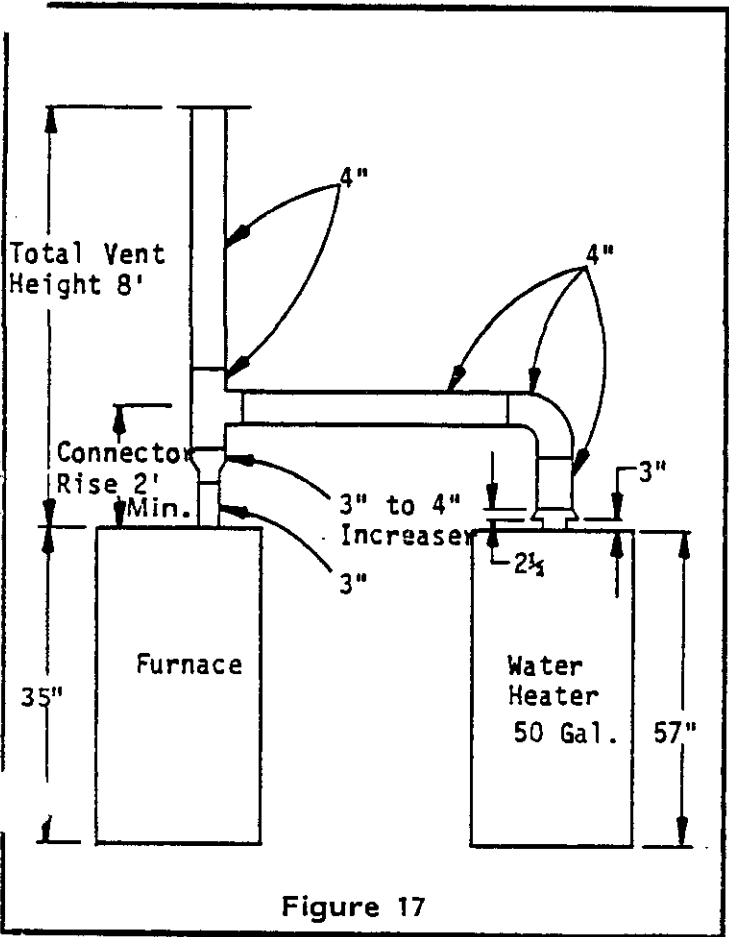

Figure 17

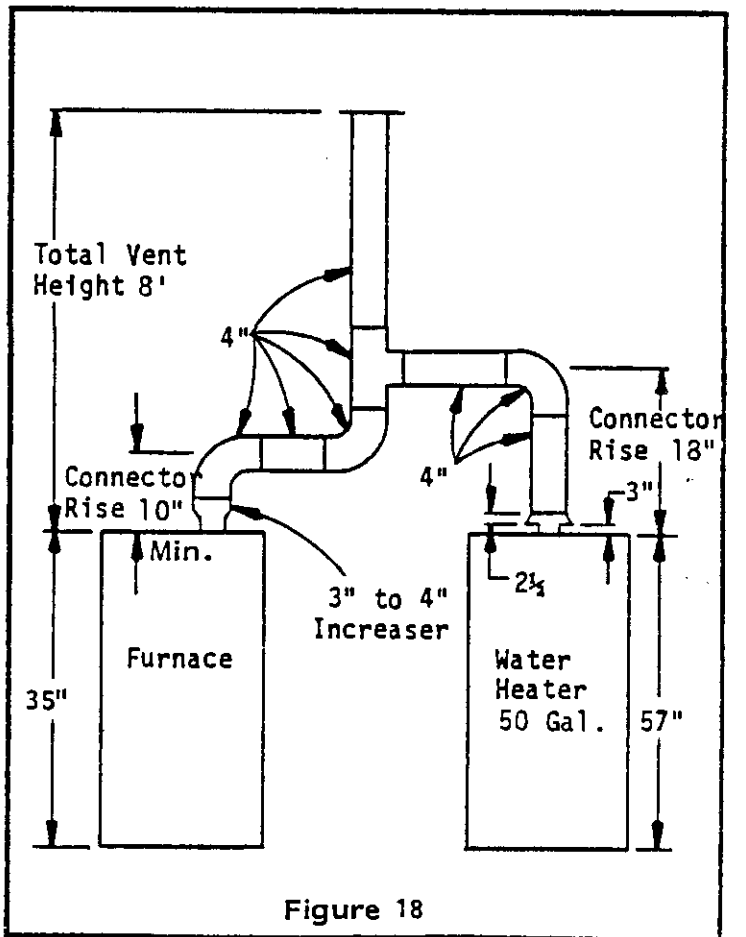

Figure 18

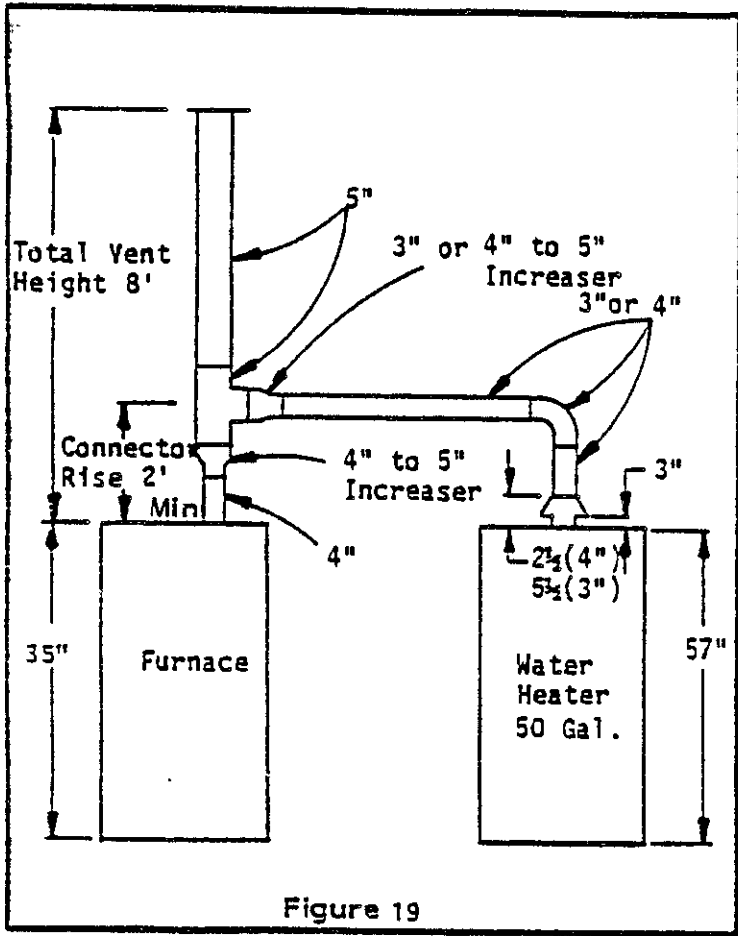

Figure 19

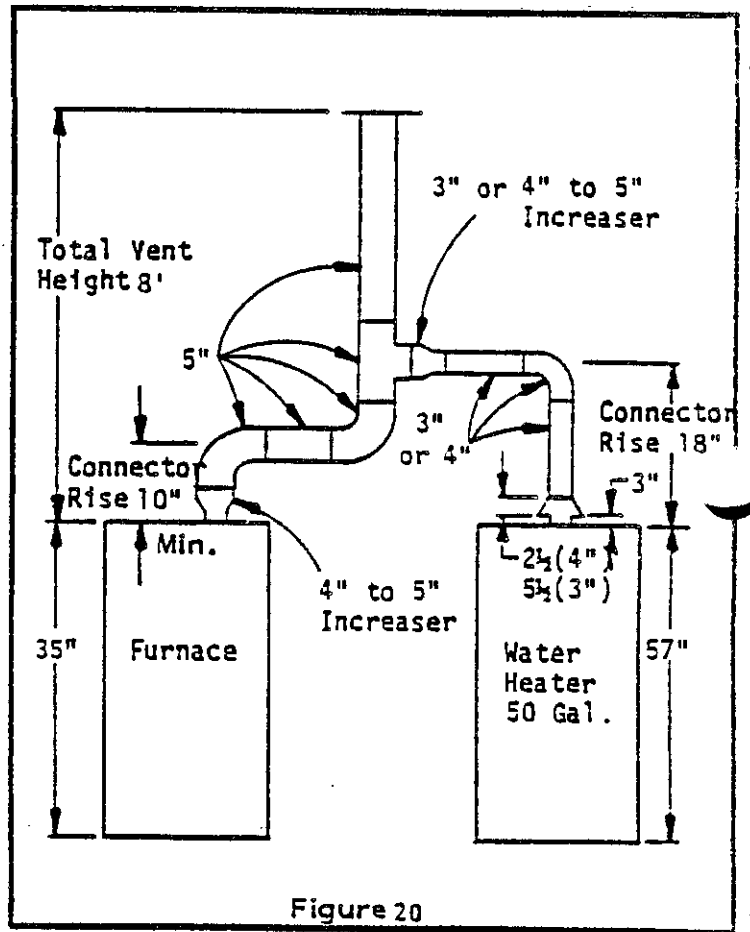

Figure 20