

INSTALLATION INSTRUCTIONS

SPLIT AIR CONDITIONER OUTDOOR SECTION

MODELS

18ECQ4	36ECQ5	60ECQ1
24ECQ5	42ECQ1	
30ECQ5	48ECQ2	

60HZ/50HZ

**FOR USE WITH:
MATCHING INDOOR BLOWER
COIL UNITS AND MATCHING
ADD ON COIL UNITS ONLY**

MANUAL 2100-133 REV. P
SUPERSEDES REV. N
FILE VOL. I, TAB 4

COPYRIGHT FEBRUARY, 1989
BARD MANUFACTURING COMPANY
BRYAN, OHIO

TABLE OF CONTENTS

I.	Application and Location	6
	General	6
	Shipping Damage	6
	Application	6
	Location	7
	Mounting Unit Outside On Slab	7
	Important Installer Note.	7
	Installing Refrigerant Tubing	7
	Precharged Tubing Connections: Quick Connect Indoor Unit and Quick Connect Outdoor Unit	8
	Field Fabricated Tubing Connections: Sweat Indoor Unit and Quick . . Connect Outdoor Unit Using CTO kit	10
II.	Wiring Instructions	12
	General	12
	Control Circuit Wiring	12
	Crankcase Heaters	13
	Wire Diagrams	14 - 15
	Wall Thermostats	16
III.	Charging Instructions	16
	Pressure Service Ports	16
	Wiring Diagram	17
	System Start-Up	17
IV.	Service	19
	Service Hints	19
	Fan Blade Setting Dimensions	19
	Pressure Charts	20 - 22

FIGURES AND TABLES

Figure 1	1
Figure 2	6
Figure 3	7
Figure 4	8
Figure 5	13
Figure 6	19

Table 1	1
Table 2	2
Table 3	3
Table 4	4
Table 4A	5
Table 4B	5
Table 5	9
Table 6	11
Table 7	12
Table 8	13
Table 9	16
Table 10	16
Table 11	17
Table 12	17
Table 13	18
Table 14	20
Table 15	20
Table 16	20
Table 17	21
Table 18	21
Table 19	22
Table 20	22

FIGURE 1

NOMENCLATURE EXPLANATION - Example:

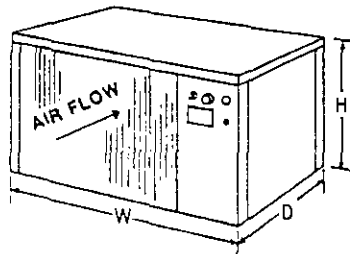
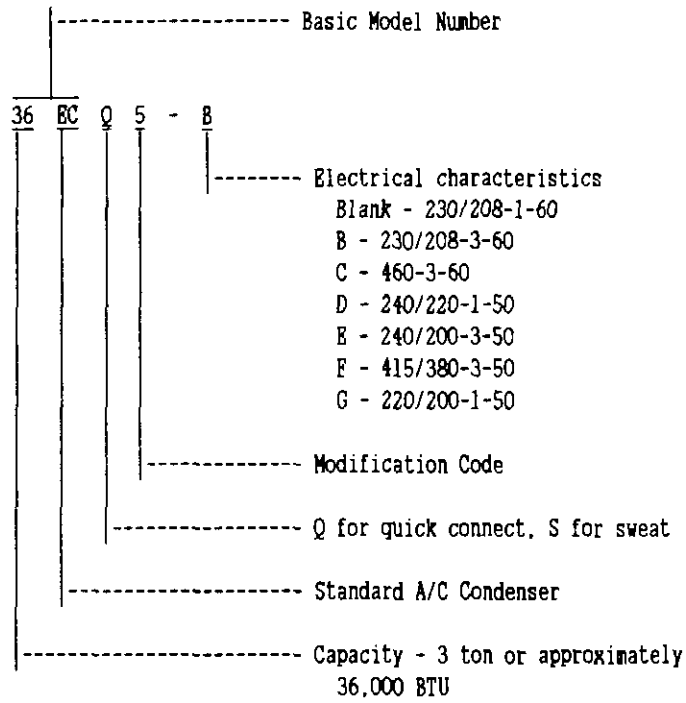

TABLE 1 CONDENSING UNITS--Dimensions (Inches)

Model Number	Width "W"	Depth "D"	Height "H"
18ECQ			
24ECQ	36	18	21
30ECQ			
36ECQ	40	18	22-5/8
42ECQ			
48ECQ	48	18	30-3/4
60ECQ			

TABLE 2 CAPACITY AND EFFICIENCY RATINGS

Condensing Unit Model Number	Indoor Coil Model Number	Type	Speed	Rated Airflow		Indoor Coil Refrigerant Control Orifice Size
				CFM	(1) H2O	
18ECQ4	BC24B	B	L	650	.40	.052 <
24ECQ5	A30AQ-A	A		875	.15	.063
	BC24B	B	H	800	.35	.059
30ECQ5	A30AQ-A	A		1000	.20	.063
	BC30B	B	H	825	.10	.063
	BC35B	B	H	1050	.50	Cap Tube
	BC36B	B	H	1050	.60	.072
36ECQ5	A36AQ-A	A		1200	.30	.069 <
	BC35B	B	H	1275	.40	Cap Tube
	BC36B	B	H	1275	.50	.072
42ECQ1	A42AQ-A	A		1450	.30	.078
	A48AQ-A	A		1450	.50	.078 <
	BC48A	B	L	1575	.40	Cap Tube
	BC48B	B	L	1525	.35	.078
48ECQ2	A48AQ-A	A		1500	.25	.081
	BC48A	B	H	1725	.30	Cap Tube
	BC48B	B	H	1700	.25	.078
	BC60B	B	H	1700	.45	.078 <
60ECQ1	A60AQ-A	A		1920	.30	.092
	BC48A	B	H	1625	.30	Cap Tube
	BC60A	B	H	1800	.30	Cap Tube
	BC60B	B	H	1800	.20	.092

(1) Static pressure loss for add-on coils and available static pressure for duct system on blower coils.

< Installer must change indoor coil refrigerant control orifice for system match as listed. Correct orifice shipped with outdoor unit.

TABLE 3

CAPACITY AND EFFICIENCY RATINGS

Condensing Unit Model Number	Indoor Coil Model Number	Type	Speed	Rated Airflow		Indoor Coil Refrigerant Control Orifice Size
				CFM	(1) H ₂ O	
18ECQ4-D	BC24B	B	H	630	.35	.052 <
24ECQ5-D	BC24B	B	H	700	.15	.059
36ECQ5-D	BC35B	B	H	1080	.15	Cap Tube
	BC36B	B	H	1080	.15	.072
37ECQ1-E	BC35B	B	H	1080	.15	Cap Tube
	BC36B	B	H	1080	.15	.072
42ECQ1-D 42ECQ1-E 42ECQ1-F	BC48A	B	H	1350	.45	Cap Tube
	BC48B	B	L	1270	.35	.078
48ECQ2-G 48ECQ2-E 48ECQ2-F	BC48A	B	H	1350	.45	Cap Tube
	BC48B	B	H	1400	.25	.078
60ECQ1-G 60ECQ1-E 60ECQ1-F	BC60A	B	H	1350	.45	Cap Tube
	BC60B	B	H	1500	.20	.092

(1) Static pressure loss for add-on coils and available static pressure for duct system on blower coils.

< Installer must change indoor coil refrigerant control orifice for system match as listed. Correct orifice shipped with outdoor unit.

TABLE 4

SPECIFICATIONS--SPLIT AIR CONDITIONING

MODEL	18ECQ4	24ECQ5	30ECQ5	36ECQ5	42ECQ1	48ECQ2	60ECQ1
Electrical Rating (60Hz/V/Ph)	230/208 1	230/208 1	230/208 1	230/208 1	230/208 1	230/208 1	230/208 1
Operating Voltage Range	197-253	197-253	197-253	197-253	197-253	197-253	197-253
Minimum Circuit Ampacity	12.8	17.8	20.4	29	30	32	39
*Field Wire Size	#14	#12	#10	#10	#10	#8	#8
**Delay Fuse Max or Ckt Bkr	20	30	35	50	50	50	60
Total Unit Amps 230/208	9.6/10.6	12.6/14.6	15.6/16.6	20.6/23.6	24.3	23.0	31.8
COMPRESSOR							
Volts	230/208	230/208	230/208	230/208	230/208	230/208	230/208
Rated Load Amps 230/208	8/9	11/13	14/15	19/22	21.5	23	29
Branch Circuit Selection Current	9	13	15	22	21.5	23	29
Lock Rotor Amps 230/208	49/49	60/60	90/90	108/108	95.4	130	132
Crankcase Heat	Innersion						
FAN MOTOR AND CONDENSER							
Fan Motor--HP/RPM	1/5 - 1075		1/5 - 1050		1/3-825		
Fan Motor--Amps	1.5	1.5	1.6	1.6	2.8	2.8	2.8
Fan--Dia./CFM	18" - 1970		20"-2700	20"-2700	24"-3750	24"-3750	24"-3350
Face Area Sq. Ft./Rows/Fins Per Inch	3.75/2/18		5.04/2/13	5.04/2/13	7.7/2/15		7.7/3/14
REFRIGERANT CONNECTION & CHARGE							
QUICK CONNECT SYSTEM							
Suction Line Fitting	-10	-10	-10	-10	-12	-12	-12
Liquid Line Fitting	-6	-6	-6	-6	-6	-6	-6
Factory Charge R-22 (Oz.)	29	40	50	58	84	86.5	101
Shipping Weight lbs.	128	140	170	190	230	275	300
* 60°C Copper wire size.							
** Maximum time delay fuse or HACR Type circuit breaker.							

TABLE 4A

SPECIFICATIONS--SPLIT AIR CONDITIONING

MODEL	18ECQ4-D	24ECQ5-D	36ECQ5-D	37ECQ1-E	42ECQ1-D	42ECQ1-E	42ECQ1-F
Electrical Rating (50Hz/V/Ph)	240/220 1	240/220 1	240/220 1	240/200 3	240/220 1	240/200 3	415/380 3
Operating Voltage Range	198-254	198-254	198-254	180-254	198-254	180-254	342-456
Minimum Circuit Ampacity	11	14	21	20	21	20	15
Delay Fuse Max or Circuit Breaker	15	20	35	30	35	30	15
Total Unit Amps	8.5	11.5	17	15.8	17.2	15.7	9.7
COMPRESSOR							
Volts	240/220	240/220	240/220	240/200	240/220	240/200	415/380
Rated Load Amps	7	10	15.5	14.3	15.5	14	8
Branch Circuit Selection Current	7	10	15.5	14.3	15.5	14	8
Lock Rotor Amps	46.5	54	68	74	68	82	41
FAN MOTOR AND CONDENSER							
Fan Motor--HP/RPM	1/5 - 1100		1/5 - 1050		1/3 - 900		
Fan Motor--Amps	1.5		1.5		1.7		
Fan--Dia./CFM	18" - 1950		20" - 1950		24" - 3400		
Face Area Sq. Ft./Rows/Fins Per Inch	3.75/2/18		5.04/2/13		7.7/2/15		
Factory Charge R-22 (Oz.)	29	40	58	59	84	84	84
Shipping Weight lbs.	128	140	190	190	225	225	225

TABLE 4B

SPECIFICATIONS--SPLIT AIR CONDITIONING

MODEL	48ECQ2-G	48ECQ2-E	48ECQ2-F	60ECQ1-G	60ECQ1-E	60ECQ1-F
Electrical Rating (50Hz/V/Ph)	220/200 1	240/200 3	415/380 3	220/200 1	240/200 3	415/380 3
Operating Voltage Range	180-242	180-254	342-456	180-242	180-254	342-456
Minimum Circuit Ampacity	30	24	15	45	27	15
Delay Fuse Max or Circuit Breaker	50	35	20	70	45	25
Total Unit Amps	24.4	18.2	11.7	36.2	21.9	12.3
COMPRESSOR						
Volts	220/200	220/200	415/380	220/200	220/200	415/380
Rated Load Amps	22.7	16.5	10	34.5	20.2	10.6
Branch Circuit Selection Current	22.7	16.5	10	34.5	20.2	10.6
Lock Rotor Amps	115	93	47	179	135	70
FAN MOTOR AND CONDENSER						
Fan Motor--HP/RPM	1/3 - 900					
Fan Motor--Amps	1.7					
Fan--Dia./CFM	24" - 3400					
Face Area Sq. Ft./Rows/Fins Per Inch	7.7/3/14					
Factory Charge R-22 (Oz.)	86.5	86.5	86.5	101	101	101
Shipping Weight lbs.	276	276	276	295	295	295

I. APPLICATION AND LOCATION

GENERAL

These instructions explain the recommended method to install the air cooled remote type condensing unit, the interconnecting refrigerant tubing, and the electrical wiring connections to the unit.

The condensing units are to be used in conjunction with the matching evaporator coils or evaporator blower units for comfort cooling applications as shown in the specification sheet.

These instructions and any instructions packaged with any separate equipment required to make up the entire air conditioning system should be carefully read before beginning the installation. Note particularly "Connecting Quick-Connect Couplings, Starting Procedure" and any tags and/or labels attached to the equipment.

While these instructions are intended as a general recommended guide, they do not supersede any national and/or local codes in any way. Authorities having jurisdiction should be consulted before the installation is made.

SHIPPING DAMAGE

Upon receipt of equipment, the carton should be checked for external signs of shipping damage. If damage is found, the receiving party must contact the last carrier immediately, preferably in writing, requesting inspection by the carrier's agent.

APPLICATION

Size of unit for a proposed installation should be based on heat loss calculation made according to methods of Air Conditioning Contractors of America. The air duct should be installed in accordance with the Standards of the National Fire Protection Association for the Installation of Air Conditioning and Ventilating Systems of Other Than Residence Type, NFPA No. 90A, and Residence Type Warm Air Heating and Air Conditioning Systems, NFPA 90B. Where local regulations are at a variance with instructions, installer should adhere to local codes.

FIGURE 2

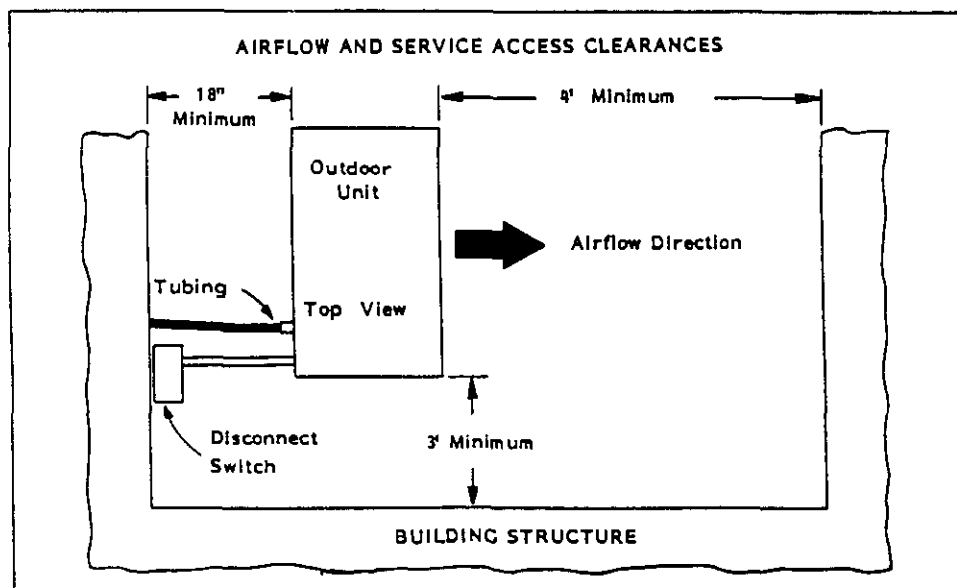

LOCATION

The condensing unit is designed to be located outside with free and unobstructed condenser air inlet and discharge. It must also permit access for service and installation. Refrigerant and electrical connections are made from the rear of the unit as shown in Figure 2 with electrical service access on the left side.

MOUNTING UNIT OUTSIDE ON SLAB

A solid level base or platform, capable to support the unit's weight, must be set at the outdoor unit predetermined location. The base should be at least two inches larger than the base dimensions of the unit and at least two inches higher than surrounding grade level. The required unit minimum installed clearances must be maintained as called out in Figure 2 when locating and setting the base.

Remove the unit from its shipping carton and position the unit on the prepared base or platform.

Do not attach the unit or its base to the building structure to avoid the transmission of noise into the occupied area.

NOTE: These units employ internally sprung compressors; therefore, it is not necessary to remove or loosen the base mounting bolts on the compressor prior to operation.

Consideration should be given to the electrical and tubing connections when placing the unit to avoid unnecessary bends or length of material.

IMPORTANT INSTALLER NOTE:

For improved start-up performance, wash the indoor coil with a dishwasher detergent.

INSTALLING REFRIGERANT TUBING

The information that follows on installing refrigerant tubing and for changing the system orifice (if required) covers applications listed in the front of this installation instruction only. Although other indoor units may be of similar construction, the installation instructions for these units should be consulted for proper installation of those units prior to installation.

This information is provided for the field service personnel to install refrigerant tubing in compliance with Section 608 of Title VI National Recycling and Emission Reduction Program for the U.S. Clean Air Act effective July 1, 1992.

Consult manual 2100-002 on procedure for leak test--evacuation--charging before installation refrigerant tubing that requires any refrigerant recovery or system evacuation. Manual 2100-002 is included with the unit installation instruction package when shipped from the factory.

FIGURE 3

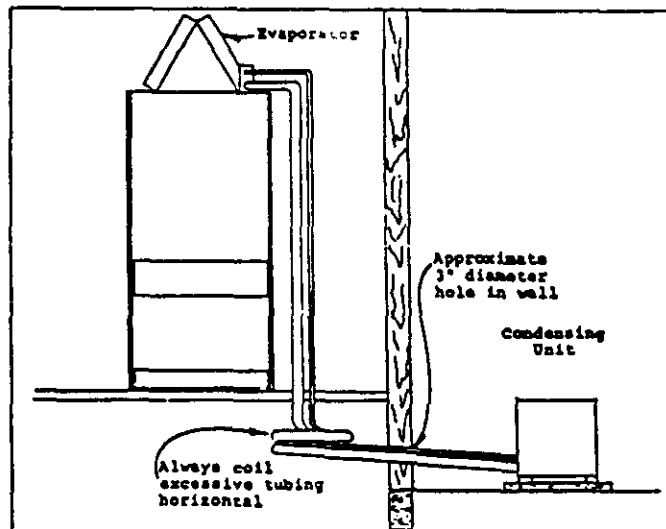

PRECHARGED TUBING CONNECTIONS: QUICK CONNECT INDOOR UNIT AND QUICK CONNECT OUTDOOR UNIT (1)

Examine carefully the two lengths of precharged tubing furnished with the system. The larger is the suction line and the smaller is the liquid line. The end of the tubing with the hex nut and gauge port is to be attached to the outdoor unit.

STEP 1--Unroll the tubing, being careful not to kink and route both the suction line and liquid line between the indoor unit and outdoor unit.

Before fastening either end, use a tubing bender to make any necessary bends in tubing. When necessary to bend the insulated tube suction line, cut the insulation around its circumference at a distance far enough beyond the point of the bend so as to clear the tubing bender. Slip the insulation back together and vapor seal the joint with tape. Coil any excess tubing in a horizontal place with the slope of the tubing toward the condensing unit.

CAUTION: 1. Be careful not to tear the insulation when pushing it through hole in masonry or frame walls. 2. When sealing the tube opening in house wall, use a soft material to prevent tube damage and vibration transmission. 3. Avoid excessive bending in any one place to avoid kinking.

NOTE: DO NOT CONNECT LINE SETS! If orifice needs to be changed, change out orifice first.

If the orifice does not have to be changed, skip the instructions outlined further in Step 2 and proceed to Step 9.

STEP 2--To recover charge from the indoor unit.

- A. Connect the suction line only to the indoor unit as outlined in Steps 9, 10, and 11.
- B. Recover indoor unit and suction line unit charge through service port located on suction line.

STEP 3--Disassemble Flow Control Assembly by turning body hex.

STEP 4--If existing orifice has not dropped out of the body when disassembled, remove by using a pin or paper clip. Discard this original orifice.

STEP 5--Insert proper sized orifice fully into the flow control body with rounded "bullet" nose towards the unit as shown. Insure the orifice stays inserted in body before connecting mating half. See chart in the outdoor unit installation instructions for proper size.

CAUTION: Be sure there is no dirt introduced into the flow control--orifice assembly. Be sure and install the orifice with the bullet nose pointing in the proper direction as shown in Figure 4. Failure to do so will result in improper operation.

FIGURE 4
FLOW CONTROL ASSEMBLY
FIELD ORIFICE REPLACEMENT INSTRUCTIONS

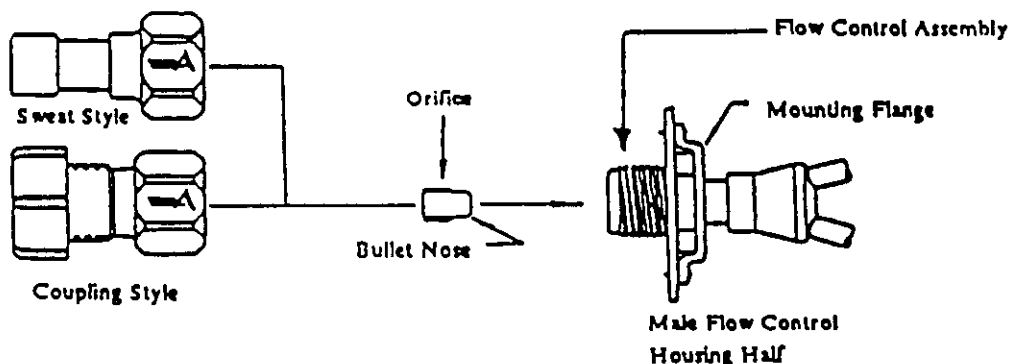

STEP 6--Thread assembly halves together by hand to insure proper mating of threads and tighten until bodies "bottom" or a definite resistance is felt.

STEP 7--Using a marker pen or ink pen, mark a line lengthwise from the union nut to the bulkhead. Then tighten an additional 1/6 turn (or 1 hex flat). The misalignment of the line will show the amount the assembly has been tightened. This final 1/6 turn is necessary to insure the formation of the leakproof joint.

STEP 8--Evacuate the suction line and indoor unit through service port located on suction line before connecting all other tubing. Refer to section later in installation instructions for details on setting the proper refrigerant charge.

STEP 9--Remove (remaining) protector caps and plugs (if orifice was changed), inspect fittings and if necessary carefully wipe coupling seats and threaded surfaces with a clean cloth to prevent the inclusion of dirt or any foreign material in the system.

STEP 10--Lubricate male half diaphragm and synthetic rubber seal with refrigerant oil. Starting with the indoor coil thread coupling halves together by hand to insure proper mating of threads. Be sure to hold the coupling firmly to prevent movement of the coupling and tubing. Failure to do so could tear out the diaphragm causing a blockage of the system. Use proper size wrenches (on coupling body hex and on union nut) and tighten until coupling bodies "bottom" or a definite resistance is felt.

CAUTION: After starting to tighten up the fitting, never try to back it off or take it apart.

STEP 11--Using a marker or ink pen, mark a line lengthwise from the coupling union nut to the bulkhead. Then tighten an additional 1/4 turn. The misalignment of the line will show the amount the coupling has been tightened. This final 1/4 turn is necessary to insure the formation of leak proof joint. If a torque wrench is used, the following torque values are recommended:

TABLE 5

Coupling Size	Ft. Lbs.
-6	10 - 12
-10	35 - 45
-11	35 - 45
-12	50 - 65

Repeat Step 10 and 11 on outdoor section making sure to locate the gauge port in a 45° angle from a vertical up position so as to be accessible for gauge connections.

STEP 12--Leak test all connections using an electronic leak detector or a halide torch.

STEP 13--When tubing is installed in attics or drop ceilings, insulate the couplings on the larger tube thoroughly with 3/8" wall thickness, closed cell sponge tube insulation or equivalent. Failure to insulate will result in water damage to ceiling since the fitting will "sweat" and drop water on the ceiling.

(1) NOTE: The maximum distance for precharge tubing between the outdoor and indoor unit is 45 feet.

FIELD FABRICATED TUBING CONNECTIONS: SWEAT INDOOR UNIT AND QUICK CONNECT OUTDOOR UNIT USING CTO KIT

Use only refrigeration grade (dehydrated and sealed) copper tubing. Care must be taken to insure that the tubing is kept clean and dry before and during installation. Do not remove the plugs from the tubing ends, coil connections or base valves until the connection is ready to be brazed.

The suction line must be insulated with a minimum of 3/8" Armaflex or equivalent before cutting and making connections.

STEP 1--Being careful not to kink, route both the suction line and liquid line between the indoor unit and outdoor unit. Use a tubing bender to make any necessary bends in tubing. When necessary to bend the insulated tube suction line, cut the insulation around its circumference at a distance far enough beyond the point of the bend so as to clear the tubing bender. Slip the insulation back together and vapor seal the joint with tape. Coil any excess tubing in a horizontal place with the slope of the tubing toward the condensing unit.

CAUTION: 1. Be careful not to tear the insulation when pushing it through hole in masonry or frame walls. 2. When sealing the tube opening in house wall, use a soft material to prevent tube damage and vibration transmission. 3. Avoid excessive bending in any one place to avoid kinking.

STEP 2--The tubing ends should be cut square. Make sure it is round and free of burrs at the connecting ends. Clean the tubing to prevent contaminants from entering the system.

NOTE:	Do not braze lines to indoor unit or make any tubing connections at outdoor unit at this time.
--------------	--

If the orifice does not have to be changed, skip the instructions outlined further in Step 3 and proceed to Step 8.

STEP 3--Disassemble Flow Control Assembly by turning body hex.

STEP 4--If existing orifice has not dropped out of the body when disassembled, remove by using a pin or paper clip. Discard this original orifice.

STEP 5--Insert proper sized orifice fully into the flow control body with rounded "bullet" nose towards the unit as shown. Insure the orifice stays inserted in body before connecting mating half. See chart in the outdoor unit installation instructions for proper size.

CAUTION: Be sure there is no dirt introduced into the flow control--orifice assembly. Be sure and install the orifice with the bullet nose pointing in the proper direction as shown in Figure 4. Failure to do so will result in improper operation.

STEP 6--Thread assembly halves together by hand to insure proper mating of threads and tighten until bodies "bottom" or definite resistance is felt.

STEP 7--Using a marker pen or ink pen, mark a line lengthwise from the union nut to the bulkhead. Then tighten an additional 1/6 turn (or 1 hex flat). The misalignment of the line will show the amount the assembly has been tightened. This final 1/6 turn is necessary to insure the formation of the leakproof joint.

STEP 8--DO NOT make any tubing connection at outdoor unit at this time. Make all brazing of joints and evacuate both suction line, liquid line, and indoor coil first.

Wrap a wet rag around the copper stub before brazing.

STEP 9--Flux the copper tube and insert into the stub. Braze the joint using an alloy of silver or copper and phosphorus with a melting temperature above 1100°F for copper to copper joints. The phosphorus will act as a flux, therefore, no flux will be required.

A copper-silver alloy with a high silver content should be used when iron or steel material is involved in the joint. These alloys require the use of silver solder flux. Alloys containing phosphorus should not be used with iron or steel. Phosphorus reacts with iron, forming iron phosphate which is extremely brittle.

CAUTION: 1. Brazing alloys with a melting temperature below 700°F should not be used. 2. Lead-tin or tin-antimony solders should not be used due to their low melting point and necessity for corrosive fluxes.

To further prevent the formation of copper oxide inside the tubing, dry nitrogen may be purged through the refrigerant system during brazing.

WARNING: Never purge or pressurize a system with oxygen. An explosion and fire will result.

STEP 10--After brazing, quench with wet rag to cool the joint and remove any flux residue.

STEP 11--Leak test all connections using an electronic leak detector or a halide torch.

STEP 12--Evacuate the suction line, liquid line, and indoor unit through service ports located on suction and liquid line before connecting to outdoor unit. Refer to section later in installation instructions for details on setting the proper refrigerant charge.

STEP 13--Remove (remaining) protector caps and plugs (on outdoor unit). Inspect fittings and if necessary carefully wipe coupling seats and threaded surfaces with a clean cloth to prevent the inclusion of dirt or any foreign material in the system.

STEP 14--Lubricate male half diaphragm and synthetic rubber seal with refrigerant oil. Start with the indoor coil, thread coupling halves together by hand to insure proper mating of threads. Be sure to hold the coupling firmly to prevent movement of the coupling and tubing. Failure to do so could tear out the diaphragm causing a blockage of the system. Use proper size wrenches (on coupling body hex and on union nut) and tighten until coupling bodies "bottom" or a definite resistance is felt.

CAUTION: After starting to tighten up the fitting, never try to back it off or take it apart.

STEP 15--Using a marker or ink pen, mark a line lengthwise from the coupling union nut to the bulkhead. Then tighten an additional 1/4 turn: The misalignment of the line will show the amount the coupling has been tightened. This final 1/4 turn is necessary to insure the formation of leak proof joint. If a torque wrench is used, the following torque values are recommended.

TABLE 6

Coupling Size	Ft. Lbs.
-6	10 - 12
-10	35 - 45
-11	35 - 45
-12	50 - 65

STEP 16--Leak test all connections using an electronic leak detector or a halide torch.

STEP 17--When tubing is installed in attics or drop ceilings, insulate the couplings on the larger tube thoroughly with 3/8" wall thickness, closed cell sponge tube insulation or equivalent. Failure to insulate will result in water damage to ceiling since the fitting will "sweat" and drop water on the ceiling.

II. WIRING INSTRUCTIONS

GENERAL

All wiring must be installed in accordance with the National Electrical Code and local codes. In Canada, all wiring must be installed in accordance with the Canadian Electrical Code and in accordance with the regulations of the authorities having jurisdiction. Power supply voltage must conform to the voltage shown on the unit serial plate. A wiring diagram of the unit is attached to the inside of the electrical cover. The power supply shall be sized and fused according to the specifications supplied. A ground lug is supplied in the control compartment for equipment ground.

The unit rating plate lists a "Maximum Time Delay Fuse" or "HACR Type" circuit breaker that is to be used with the equipment. The correct size must be used for proper circuit protection and also to assure that there will be no nuisance tripping due to the momentary high starting current of the compressor motor.

CONTROL CIRCUIT WIRING

For split systems, the minimum control circuit wiring gauge needed to insure proper operation of all controls in both indoor and outdoor units will depend on two factors.

1. The rated VA of the control circuit transformer.
2. The maximum total distance of the control circuit wiring. (This is the distance between the wall thermostat to the indoor unit plus the distance between the indoor unit to the outdoor unit.)

The following table should be used to determine proper gauge of control circuit wiring required.

TABLE 7

Rated VA of Control Circuit Transformer	Transformer Secondary FLA @ 24V	Maximum Total Distance of Control Circuit Wiring In Feet
40	1.6	20 gauge - 65
		18 gauge - 90
		16 gauge - 145
		14 gauge - 230
50	2.1	20 gauge - 45
		18 gauge - 60
		16 gauge - 100
		14 gauge - 160
		12 gauge - 250
65	2.7	20 gauge - 40
		18 gauge - 55
		16 gauge - 85
		14 gauge - 135
		12 gauge - 210

Example: 1. Control circuit transformer rated at 40VA.

2. Maximum total distance of control circuit wiring 85 feet.

From the Table 7, minimum of 18 gauge wire should be used in the control circuit wiring.

For control circuit transformers rated other than those listed, use the next lower rated transformer listed.

Example: 1. Control circuit transformer rated at 55VA.

From table use 50VA transformer.

There are two (2) separate control diagrams for fossil fuel furnaces with air conditioners.

Control diagrams for the various circuits which could be encountered with blower coils can be found in the installation instructions of the blower coil.

TABLE 8

System	Gas Furnace Control Diagram	Oil Furnace Control Diagram
All Models	4091-100	4091-101

CRANKCASE HEATERS

All units are provided with some form of compressor crankcase heat. Some single phase units utilize the compressor motor start winding in series with a portion of the run capacitor to generate heat within the compressor shell to prevent liquid refrigerant migration.

Some three phase units utilize a wraparound type of crankcase heater that warms the compressor oil from the outside.

Some single and three phase models have an insertion well-type heater located in the lower section of the compressor housing. This is a self-regulating type heater that draws only enough power to maintain the compressor at a safe temperature.

Some form of crankcase heat is essential to prevent liquid refrigerant migrating to the compressor causing oil pump out on compressor start-up and possible valve failure due to compressing a liquid.

Refer to unit wiring diagram to find exact type of crankcase heater used.

The decal in Figure 5 is affixed to all outdoor units detailing start-up procedure. This is very important. Please read carefully.

FIGURE 5

IMPORTANT

THESE PROCEDURES MUST BE FOLLOWED AT INITIAL START-UP AND AT ANY TIME POWER HAS BEEN REMOVED FOR 12 HOURS OR LONGER.

TO PREVENT COMPRESSOR DAMAGE WHICH MAY RESULT FROM THE PRESENCE OF LIQUID REFRIGERANT IN THE COMPRESSOR CRANKCASE

1. MAKE CERTAIN THE ROOM THERMOSTAT IS IN THE "OFF" POSITION. (THE COMPRESSOR IS NOT TO OPERATE).
2. APPLY POWER BY CLOSING THE SYSTEM DISCONNECT SWITCH. THIS ENERGIZES THE COMPRESSOR HEATER WHICH EVAPORATES THE LIQUID REFRIGERANT IN THE CRANKCASE.
3. ALLOW 4 HOURS OR 60 MINUTES PER POUND OF REFRIGERANT IN THE SYSTEM AS NOTED ON THE UNIT RATING PLATE, WHICHEVER IS GREATER.
4. AFTER PROPERLY ELAPSED TIME THE THERMOSTAT MAY BE SET TO OPERATE THE COMPRESSOR.
5. EXCEPT AS REQUIRED FOR SAFETY WHILE SERVICING — DO NOT OPEN SYSTEM DISCONNECT SWITCH.

7961-061

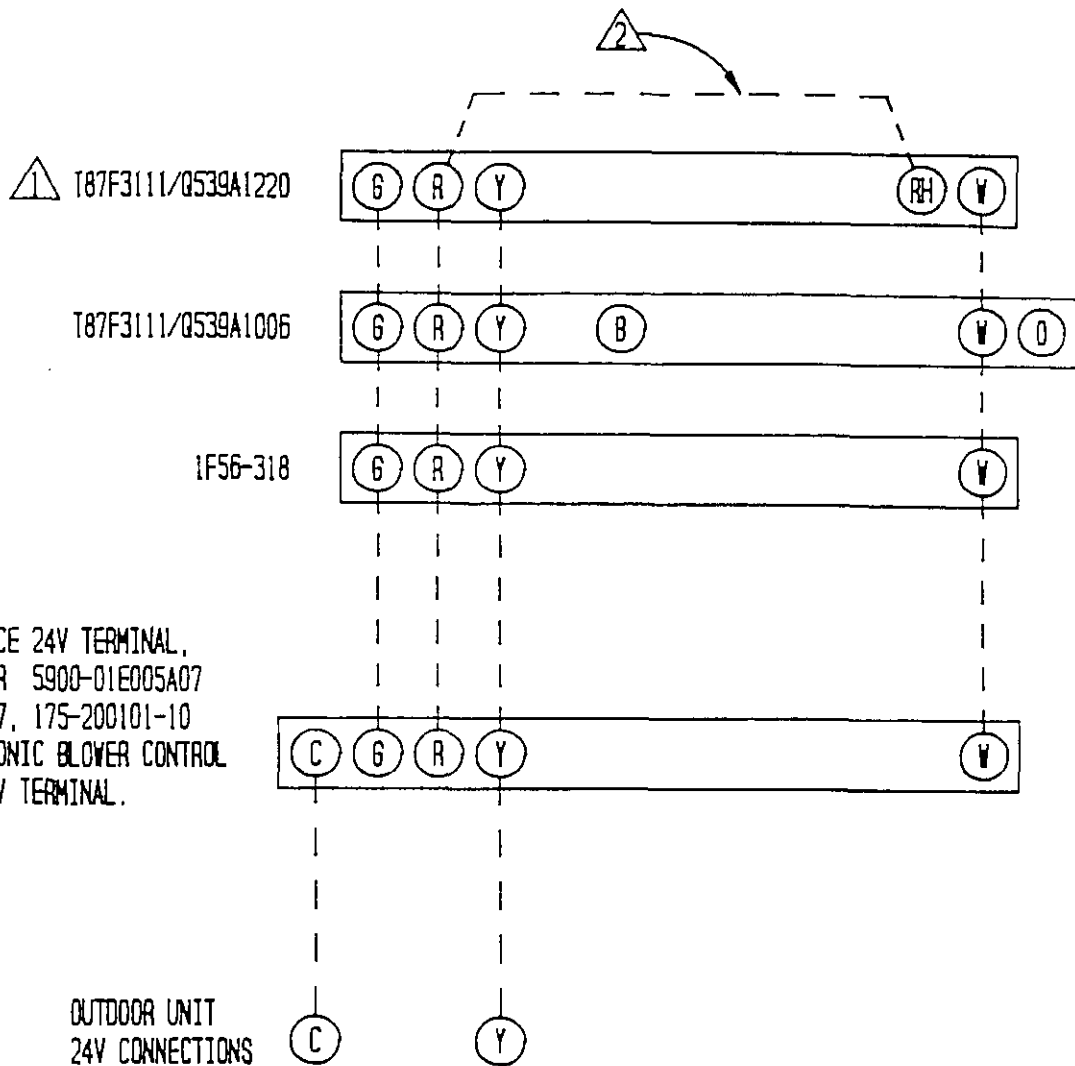

⚠ FURNACE 24V TERMINAL,
 FAN CENTER 5900-01E005A07
 R8325A1057, 175-200101-10
 OR ELECTRONIC BLOWER CONTROL
 45200, 24V TERMINAL.

OUTDOOR UNIT
 24V CONNECTIONS

- ⚠ SET ADJUST HEAT ANTICIPATOR (SEE FURNACE INSTALLATION INSTRUCTIONS)
- ⚡ INSTALL JUMPER R-RH
- ⚠ IF THE FURNACE IS NOT INTERNALLY WIRED FOR ADD ON AIR CONDITIONING, A FAN CENTER WILL NEED TO BE ADDED.

	FACTORY WIRING	FIELD WIRING
LOW VOLTAGE	— — — —	— — — —
HIGH VOLTAGE	————	- - - -

AIR CONDITIONER W/GAS FURNACE

⚠ T87F3111/Q539A1220

⚠ FURNACE 24V TERMINAL
 FAN CENTER 5900-01E005A07
 R8325A1057, 175-200101-10
 OR ELECTRONIC BLOWER CONTROL
 45200, 24V TERMINAL.

OUTDOOR UNIT
 24V CONNECTIONS

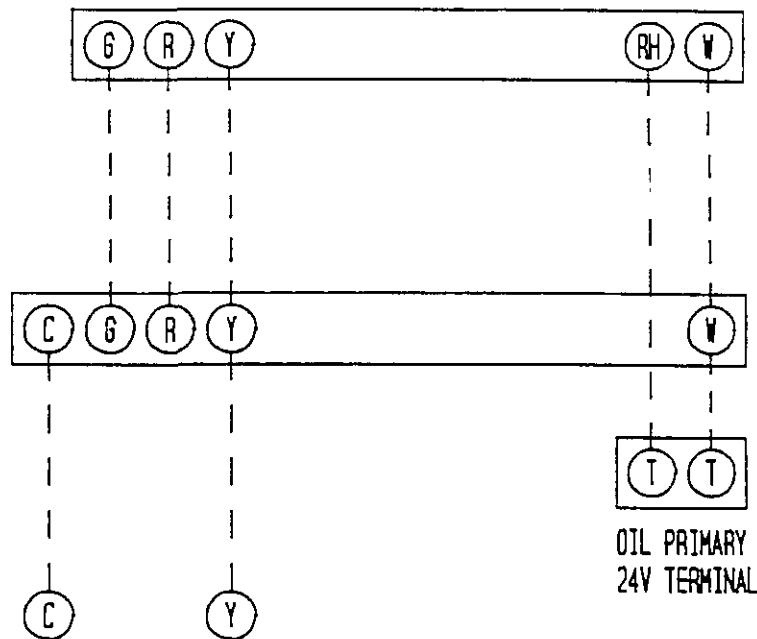

OIL PRIMARY
 24V TERMINAL

⚠ SET ADJUST HEAT ANTICIPATOR (SEE FURNACE INSTALLATION INSTRUCTIONS)

⚠ IF THE FURNACE IS NOT INTERNALLY WIRED FOR ADD ON AIR CONDITIONING, A FAN CENTER WILL NEED TO BE ADDED.

	FACTORY WIRING	FIELD WIRING
LOW VOLTAGE	_____	-----
HIGH VOLTAGE	—————	-----

AIR CONDITIONER W/OIL FURNACE

WALL THERMOSTATS

The following wall thermostats and subbases should be used as indicated, depending on the application.

TABLE 9

AIR CONDITIONING THERMOSTATS		
Part No.	Model No.	Description
8403-002	T87F3111	THERMOSTAT--1 stg. heat, adj. heater, Mercury
8404-003	Q539A1220	SUBBASE --System Heat-Off-Cool Fan: On-Auto
8403-008	ID51-605	THERMOSTAT--1 stg. cool, System w/Off Sw. Snap Action Fan: Auto-On
8403-009	IF56-318	THERMOSTAT--1 st. cool, 1 stg. heat, Adj. heater Mercury System: Heat-Off-Cool Fan: Auto-On
8403-019	T874C1000	THERMOSTAT--1 stg. cool, 2 stg. heat, Adj. heater, Mercury
8404-012	Q674A1001	SUBBASE --System: Heat-Auto-Cool Fan: Auto-On

III. CHARGING INSTRUCTIONS

PRESSURE SERVICE PORTS

High and low pressure service ports are installed on all units so that the system operating pressures can be observed. Pressure tables can be found later in the manual covering all models. It is imperative to match the correct pressure table to the unit by model number.

The pressure service ports on the split system heat pump are located on the interconnecting tubing quick connect fittings. An additional low side service port is located on the quick connect mounting plate for low side pressure during heating operation.

TABLE 10

CHARGED TUBING (For Use With "Q" Versions)					
Model No.	Stub Tube*	15'	25'	35'	45'
18BCQ4	CTO**	CT15	RW25	RW35	RW45
24BCQ5	3/8" & 3/4"	1/4" & 5/8"	1/4" & 5/8"	1/4" & 5/8"	1/4" & 5/8"
30BCQ5	CTO**	CT15	CT25	CT35	CT45
36BCQ5	3/8" & 3/4"	1/4" & 5/8"	1/4" & 3/4"	3/8" & 1/2"	3/8" & 3/4"
42BCQ1					
48BCQ1	CTO-12	CT15-12	CT25-12	CT35-12	CT45-12
60BCQ1	3/8" & 7/8"	3/8" & 7/8"	3/8" & 7/8"	3/8" & 7/8"	3/8" & 7/8"

** 1/2 stub kit available, order CTO-A.

SYSTEM START-UP

STEP 1--Close disconnect switch(es) and set the thermostat to cool and the temperature to the highest setting.

STEP 2--Check for proper airflow across the indoor coil by referring to indoor unit installation instructions.

STEP 3--Connect the service gauges and allow the unit to run for at least 10 minutes or until pressures are stable. Check pressures to the system pressure table attached to the outdoor unit service panel. For optimum system performance, go to Step 4.

STEP 4--Install a thermometer on the suction line approximately 6" to 10" from the compressor. Optimum system performance will occur with a refrigerant charge resulting in a suction line superheat as determined from the following calculations.

- A. Measure outdoor air dry bulb temperature _____ °F
- B. Measure indoor air wet bulb temperature _____ °F
- C. Measure suction pressure _____ PSIG
- D. Measure suction line temperature _____ °F
- E. Determine optimum system superheat from Table 12 using outdoor air dry bulb (Step B) and indoor air wet bulb (Step A). _____ °F
- F. Determine saturated suction temperature from suction pressure using Table 11. _____ °F
- G. Determine system superheat:
 Suction line temperature (Step D) _____ °F
 - Saturated suction temperature (Step F) - _____ °F
 = System superheat = _____ °F
- H. Adjust the system superheat (Step G) to the optimum system superheat (Step E) by adding charge to lower the superheat or removing charge to raise the superheat.
- I. Check final system operating pressures to the system pressure tables as was done in Step 3.

TABLE 11

SATURATED SUCTION TEMPERATURE (R-22)	
Suction Pressure PSIG	Saturated Suction Temperature (Deg. F)
50	26
53	28
55	30
58	32
61	34
63	36
65	38
67	39
70	41
73	43
76	45
79	47
82	49
86	51

TABLE 12

SYSTEM SUPERHEAT				
Outdoor Ambient Temperature (Deg. F Dry Bulb)	Return Air Temperature Deg. F--Wet Bulb			
	59	63	67	71
105	1	1	5	
95	1	3	(8)	20
90	1	7	14	26
85	3	9	19	33
80	8	14	25	39
75	10	20	30	42

TABLE 13

TOTAL SYSTEM OPERATING CHARGE (Includes charge for the basic outdoor unit, indoor coil and 25' of interconnecting tubing)		
Outdoor Section	Indoor Section	Total R-22 Charge (Oz.)
18ECQ4	BC24B	37
24ECQ5	A30AQ-A	51
	BC24B	48
30ECQ5	A30AQ-A	51
	BC30B	58
	BC35B	61
36ECQ5	BC36B	66
	A36AQ-A	65
	BC35B	65
42ECQ1	BC36B	70
	A42AQ-A	64
	A48AQ-A	64
48ECQ2	BC48A	79
	BC48B	63
	A48AQ-A	102.5
	BC48A	117.5
60ECQ1	BC48B	101.5
	BC60B	119.5
	A60AQ-A	117
	BC48A	132
60ECQ1	BC60A	152
	BC60B	134

The above includes 25' of 1/4" or 3/8" diameter liquid line. For other than 25' and other tube sizes, adjust the total charge according to the following schedule.

<u>Liquid Line Diameter</u>	<u>Oz. R-22 Per Ft.</u>
1/4"	.25
3/8"	.6
1/2"	1.2

INSTALLER NOTE: Stamp or mark the final system charge determined above on the outdoor unit serial plate.

Examples: 42ECQ1 and A42AQ-A with 35' liquid line
 $35' - 25' = 10' \times .6 = 6 \text{ oz.}$ $64 + 6 = 70 \text{ oz. Total}$

42ECQ1 and A42AQ-A with 18' liquid line
 $25' - 18' = 7' \times .6 = 4.2 \text{ oz.}$ $64 - 4 = 60 \text{ oz. Total}$

NOTE: Round all decimals to nearest whole number.

IV. SERVICE

SERVICE HINTS

1. Caution homeowner to maintain clean air filters at all times. Also, not to needlessly close off supply and return air registers. This reduces air flow through the system, which shortens equipment service life as well as increasing operating costs.
2. Check all power fuses or circuit breakers to be sure that they are the correct rating.
3. Periodic cleaning of the outdoor coil to permit full and unrestricted air flow circulation is essential.

FAN BLADE SETTING DIMENSIONS

Shown in the drawing below are the correct fan blade setting dimensions for proper air delivery across the outdoor coil.

Any service work requiring removal or adjustment in the fan and/or motor area will require that the dimensions below be checked and blade adjusted in or out on the motor shaft accordingly.

FIGURE 6

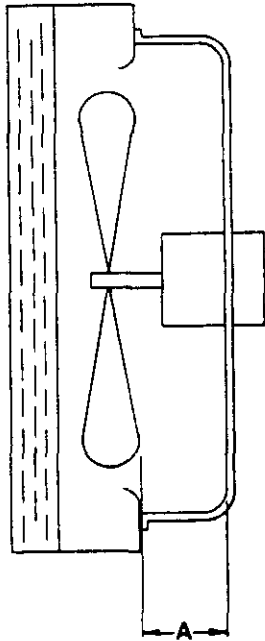

Model	Dimension A
All	1/2

18BC04--Outdoor Model
COOLING

TABLE 14
Air Temperature Entering Outdoor Coil Degree F

Indoor Model	Return Air Temperature	Pressure	°	°	°	°	°	°	°	°	°
			75	80	85	90	95	100	105	110	115
BC24B	75 deg. DB	Low Side	76	77	79	81	82	83	85	86	87
	62 deg. WB	High Side	208	222	237	252	267	283	299	316	333
	80 deg. DB	Low Side	82	83	85	87	88	89	91	92	93
	67 deg. WB	High Side	214	228	243	258	274	290	307	324	342
	85 deg. DB	Low Side	87	89	91	93	95	96	98	98	99
	72 deg. WB	High Side	221	236	251	267	283	300	317	335	354

24BC05--Outdoor Model
COOLING

TABLE 15
Air Temperature Entering Outdoor Coil Degree F

Indoor Model	Return Air Temperature	Pressure	°	°	°	°	°	°	°	°	°
			75	80	85	90	95	100	105	110	115
A36AQ-A	75 deg. DB	Low Side	72	74	75	76	77	78	79	81	82
	62 deg. WB	High Side	189	210	230	249	268	286	303	319	334
BC24B	80 deg. DB	Low Side	77	78	80	82	83	84	86	87	88
	67 deg. WB	High Side	194	216	236	256	275	293	311	327	343
	85 deg. DB	Low Side	83	84	86	87	89	91	92	94	95
	72 deg. WB	High Side	202	224	244	265	284	303	321	338	355

30BC05--Outdoor Model
COOLING

TABLE 16
Air Temperature Entering Outdoor Coil Degree F

Indoor Model	Return Air Temperature	Pressure	°	°	°	°	°	°	°	°	°
			75	80	85	90	95	100	105	110	115
BC30B	75 deg. DB	Low Side	67	69	70	71	72	73	74	76	77
	62 deg. WB	High Side	190	206	222	238	254	270	287	304	321
	80 deg. DB	Low Side	72	73	75	77	78	79	81	82	83
	67 deg. WB	High Side	195	212	228	244	261	278	295	312	330
	85 deg. DB	Low Side	76	78	80	82	84	86	87	88	89
	72 deg. WB	High Side	203	219	236	253	270	287	305	323	341
A30AQ-A	75 deg. DB	Low Side	67	69	71	73	75	76	78	78	79
	62 deg. WB	High Side	196	210	225	240	256	272	289	306	324
	80 deg. DB	Low Side	72	74	76	78	80	82	83	84	85
BC35B	67 deg. WB	High Side	201	216	231	247	263	280	297	315	333
	85 deg. DB	Low Side	76	79	82	84	86	88	89	90	91
BC36B	72 deg. WB	High Side	209	224	239	255	272	289	307	325	344
	75 deg. DB	Low Side	69	71	73	75	77	79	80	81	82
	62 deg. WB	High Side	191	205	220	235	251	268	285	303	322
	80 deg. DB	Low Side	74	76	78	80	82	84	85	87	88
	67 deg. WB	High Side	195	210	225	241	258	275	293	312	331
	85 deg. DB	Low Side	80	82	84	86	88	90	91	93	94
72 deg. WB	High Side	201	217	233	250	267	285	303	322	342	

Low side pressure + 2 PSIG (suction line @ outdoor unit quick connect)
High side pressure + 5 PSIG (liquid line @ outdoor unit quick connect)

Tables are based upon rated CFM (airflow) across the evaporator coil and should be found under section titled "Refrigerant Charge" elsewhere in manual. If there is any doubt as to correct operating charge being in the system, the charge should be removed, system evacuated, and recharged to serial plate instructions.

36BCQ5--Outdoor Model

TABLE 17

COOLING

Air Temperature Entering Outdoor Coil Degree F

Indoor Model	Return Air Temperature	Pressure	°	°	°	°	°	°	°	°	°
			75	80	85	90	95	100	105	110	115
A36AQ-A	75 deg. DB	Low Side	54	56	58	61	63	65	68	70	72
	62 deg. WB	High Side	212	228	243	259	275	291	307	322	338
BC35B	80 deg. DB	Low Side	58	60	62	65	67	69	72	74	76
	67 deg. WB	High Side	217	233	250	266	283	300	316	333	349
BC36B	85 deg. DB	Low Side	57	60	63	65	68	71	73	76	79
	72 deg. WB	High Side	228	242	257	271	285	299	313	328	342
	75 deg. DB	Low Side	65	67	68	69	70	71	73	74	75
	62 deg. WB	High Side	228	241	256	271	287	304	322	341	361
	80 deg. DB	Low Side	70	72	73	74	75	76	77	79	80
	67 deg. WB	High Side	235	248	269	281	295	313	331	351	371
	85 deg. DB	Low Side	75	76	78	80	81	82	84	85	86
	72 deg. WB	High Side	241	256	271	288	305	323	342	362	383

42BCQ1--Outdoor Model

TABLE 18

COOLING

Air Temperature Entering Outdoor Coil Degree F

Indoor Model	Return Air Temperature	Pressure	°	°	°	°	°	°	°	°	°
			75	80	85	90	95	100	105	110	115
BC48A	75 deg. DB	Low Side	72	74	75	76	77	78	79	80	82
	62 deg. WB	High Side	188	201	215	229	243	257	271	285	298
	80 deg. DB	Low Side	77	79	80	81	82	83	84	85	87
	67 deg. WB	High Side	192	206	221	235	250	265	279	294	308
	85 deg. DB	Low Side	83	85	86	87	88	89	90	91	93
	72 deg. WB	High Side	197	213	228	244	259	274	290	305	321
A42AQ-A	75 deg. DB	Low Side	64	65	67	68	70	72	73	75	76
	62 deg. WB	High Side	183	199	214	230	245	260	276	291	307
	80 deg. DB	Low Side	67	69	71	73	75	77	79	81	83
	67 deg. WB	High Side	189	205	220	236	251	266	282	297	313
	85 deg. DB	Low Side	72	74	76	79	81	83	86	88	90
	72 deg. WB	High Side	195	212	228	244	260	276	292	308	325
A48AQ-A	75 deg. DB	Low Side	65	67	69	71	73	75	77	79	81
	62 deg. WB	High Side	191	207	222	238	254	270	286	301	317
	80 deg. DB	Low Side	70	72	74	76	78	80	82	84	86
BC48B	67 deg. WB	High Side	196	213	229	245	261	277	293	309	326
	85 deg. DB	Low Side	75	77	79	82	84	86	89	91	93
	72 deg. WB	High Side	204	220	237	253	270	287	303	320	336

Low side pressure \pm 2 PSIG (suction line @ outdoor unit quick connect)

High side pressure \pm 5 PSIG (liquid line @ outdoor unit quick connect)

Tables are based upon rated CFM (airflow) across the evaporator coil and should be found under section titled "Refrigerant Charge" elsewhere in manual. If there is any doubt as to correct operating charge being in the system, the charge should be removed, system evacuated, and recharged to serial plate instructions.

48BCQ2--Outdoor Model
COOLING

TABLE 19
Air Temperature Entering Outdoor Coil Degree F

Indoor Model	Return Air Temperature	Pressure	°	°	°	°	°	°	°	°	°
			75	80	85	90	95	100	105	110	115
BC48A	75 deg. DB	Low Side	69	70	72	73	75	77	78	80	81
	62 deg. WB	High Side	206	220	235	249	263	277	291	306	320
	80 deg. DB	Low Side	74	75	77	78	80	82	83	85	86
	67 deg. WB	High Side	212	226	241	255	270	285	299	314	328
A48AQ-A	85 deg. DB	Low Side	80	81	83	84	86	88	89	91	92
	72 deg. WB	High Side	219	234	249	264	279	294	309	324	339
BC48B	75 deg. DB	Low Side	66	68	69	70	71	72	73	74	76
	62 deg. WB	High Side	188	204	221	237	254	271	287	304	320
BC48B	80 deg. DB	Low Side	71	73	74	75	76	77	78	79	81
	67 deg. WB	High Side	194	210	227	243	260	277	293	310	326
BC48B	85 deg. DB	Low Side	76	77	79	80	82	84	85	87	88
	72 deg. WB	High Side	201	218	235	252	269	286	303	320	337

60BCQ1--Outdoor Model
COOLING

TABLE 20
Air Temperature Entering Outdoor Coil Degree F

Indoor Model	Return Air Temperature	Pressure	°	°	°	°	°	°	°	°	°
			75	80	85	90	95	100	105	110	115
BC48A	75 deg. DB	Low Side	60	62	64	67	69	71	74	76	78
	62 deg. WB	High Side	190	206	221	237	253	269	285	300	316
	80 deg. DB	Low Side	65	67	69	72	74	76	79	81	83
	67 deg. WB	High Side	194	211	227	243	259	275	291	307	324
BC60A	85 deg. DB	Low Side	69	72	75	77	80	83	85	88	91
	72 deg. WB	High Side	202	218	235	251	268	285	301	318	334
BC60A	75 deg. DB	Low Side	69	71	72	73	74	75	76	77	79
	62 deg. WB	High Side	203	218	233	248	263	278	293	308	323
	80 deg. DB	Low Side	74	76	77	78	79	80	81	82	84
	67 deg. WB	High Side	209	224	239	254	269	284	299	314	329
A60AQ-A	85 deg. DB	Low Side	80	82	83	84	85	86	87	88	90
	72 deg. WB	High Side	216	232	247	263	278	293	309	324	340
BC60B	75 deg. DB	Low Side	63	65	67	69	71	73	75	77	79
	62 deg. WB	High Side	188	202	217	231	246	261	275	290	304
BC60B	80 deg. DB	Low Side	68	70	72	74	76	78	80	82	84
	67 deg. WB	High Side	192	207	222	237	252	267	282	297	312
BC60B	85 deg. DB	Low Side	73	75	77	80	82	84	87	89	91
	72 deg. WB	High Side	198	214	229	245	261	277	293	308	324

Low side pressure \pm 2 PSIG (suction line @ outdoor unit quick connect)
High side pressure \pm 5 PSIG (liquid line @ outdoor unit quick connect)

Tables are based upon rated CFM (airflow) across the evaporator coil and should be found under section titled "Refrigerant Charge" elsewhere in manual. If there is any doubt as to correct operating charge being in the system, the charge should be removed, system evacuated, and recharged to serial plate instructions.

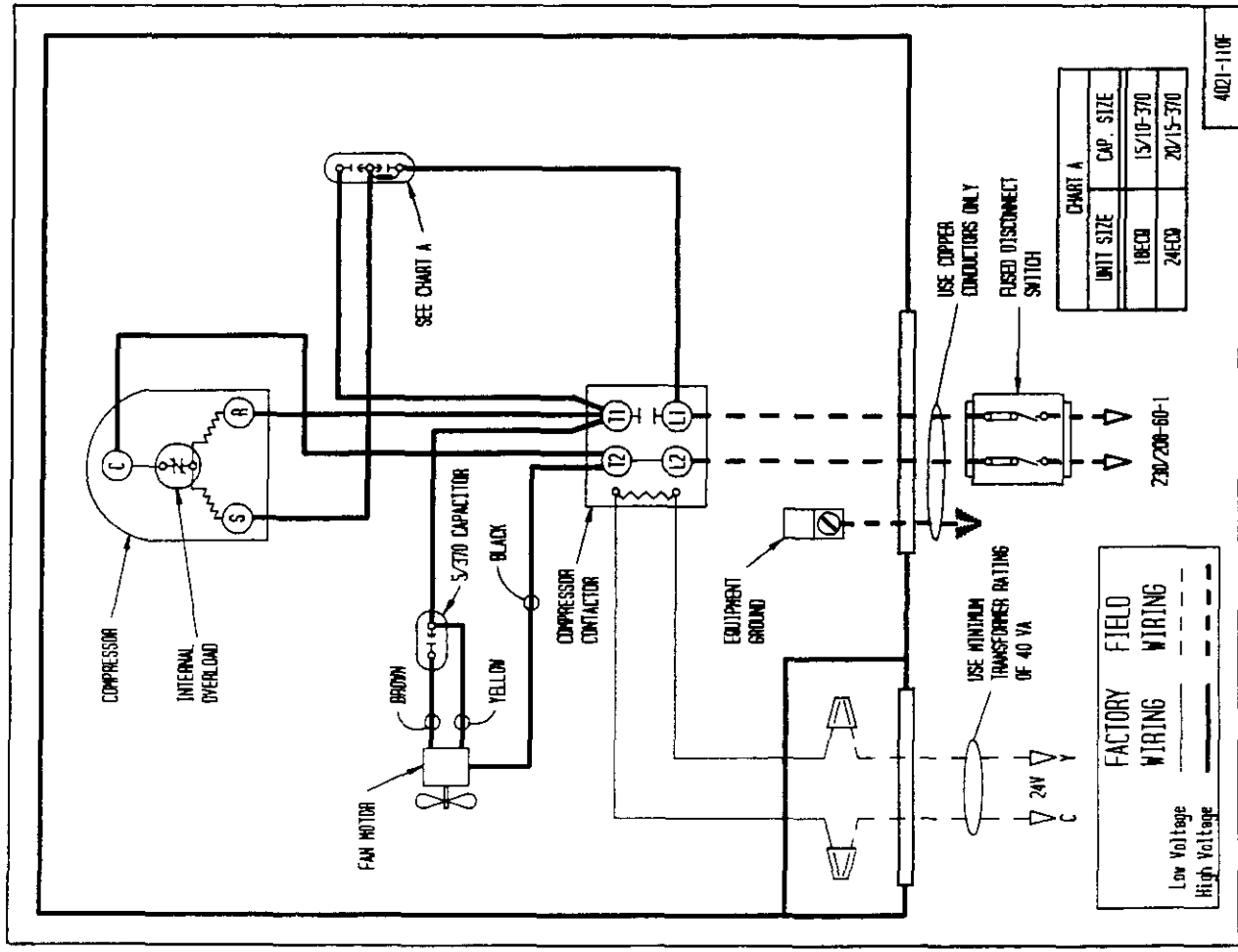
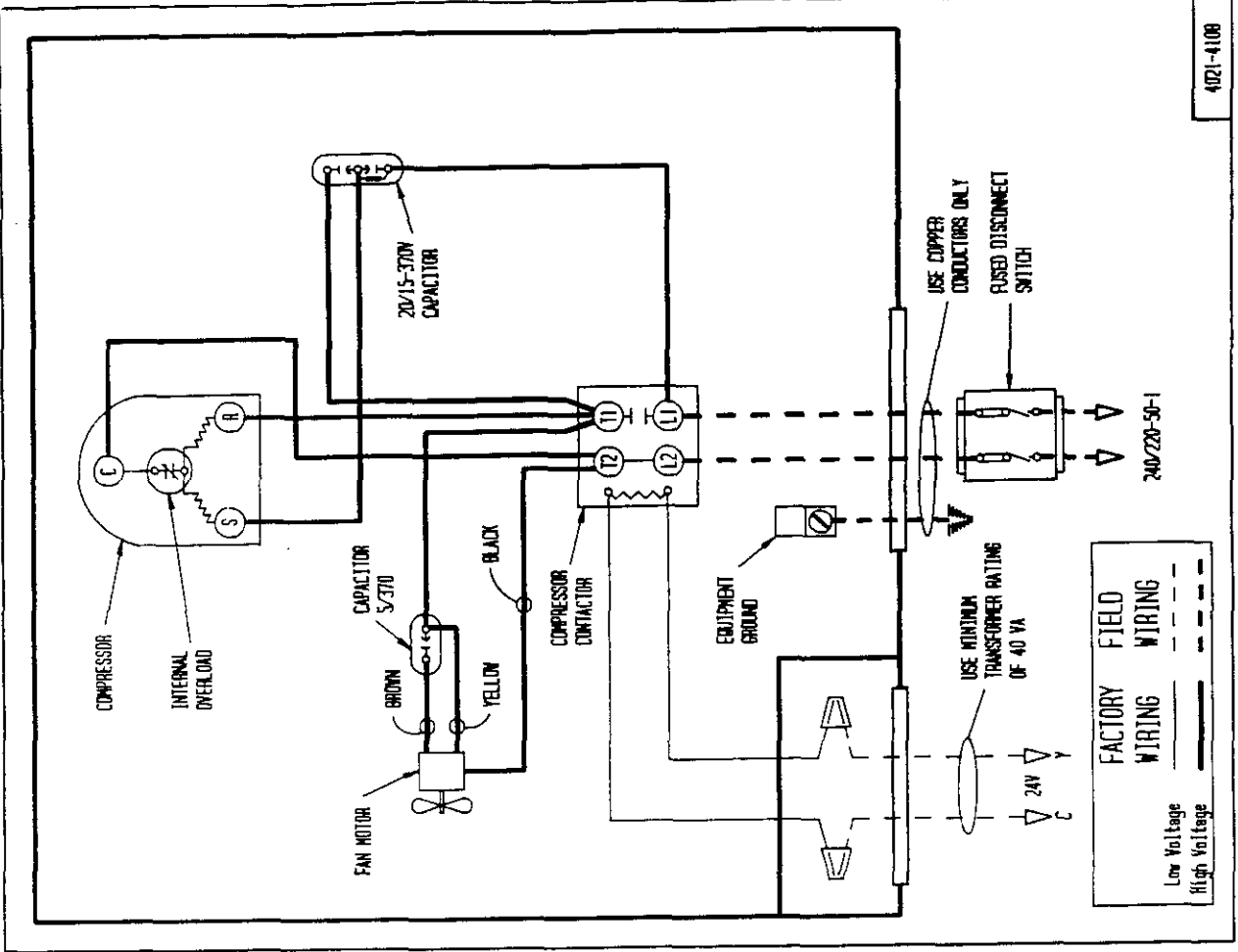

CAPACITOR	
MODEL	SIZE
1BEC04-D	25 + 5/370
2AEC05-D	35 + 5/370

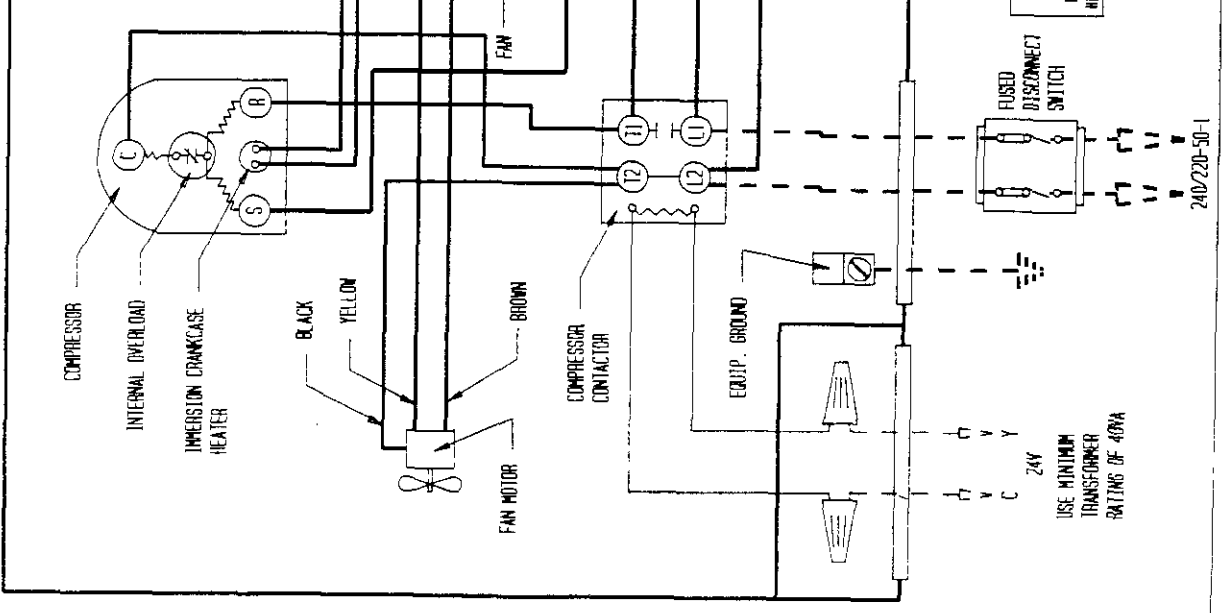

USE COPPER CONDUCTORS ONLY

FACTORY WIRING	FIELD WIRING
---	---

Low Voltage
High Voltage

FUSED DISCONNECT SWITCH

24V

USE MINIMUM TRANSFORMER RATING OF 40VA

240/220-50-1

4062-111

CAPACITOR	
MODEL	SIZE
1BEC04	25 + 5/370
2AEC05	35 + 5/370
30EC05	45 + 5/370
31EC02	35 + 5/370
36EC05	40 + 5/440
37EC01	45 + 5/440

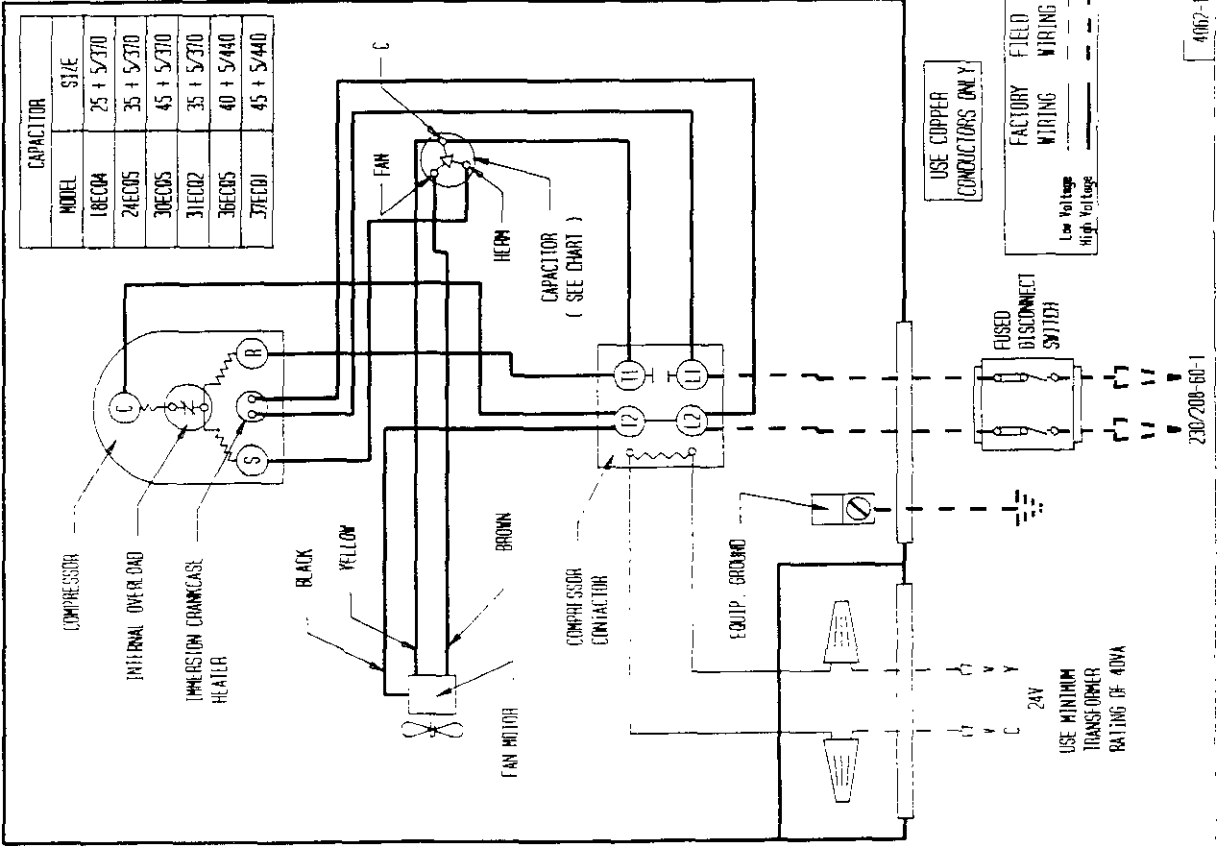

USE COPPER CONDUCTORS ONLY

FACTORY WIRING	FIELD WIRING
---	---

Low Voltage
High Voltage

FUSED DISCONNECT SWITCH

24V

USE MINIMUM TRANSFORMER RATING OF 40VA

230/208-60-1

4062-111 E

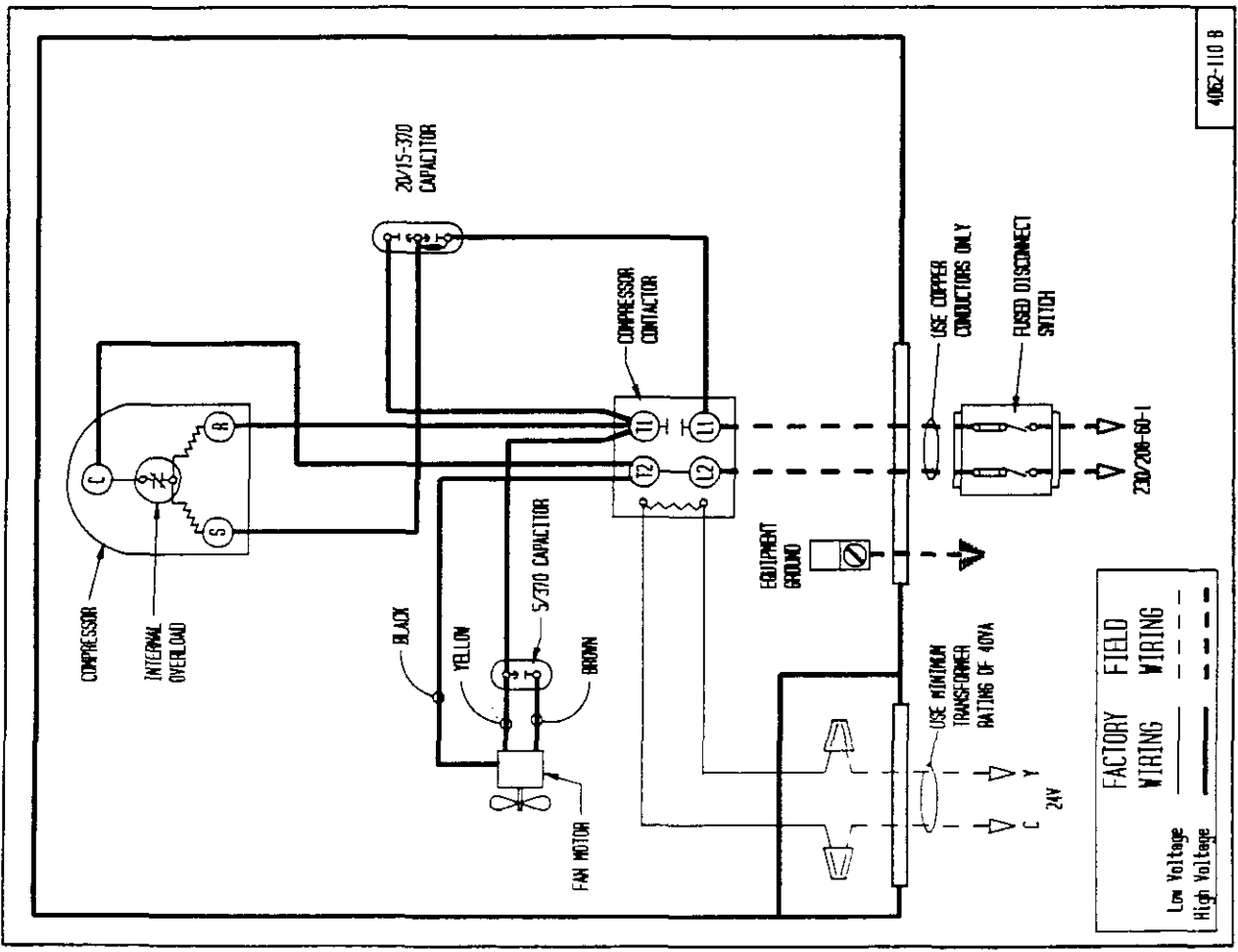
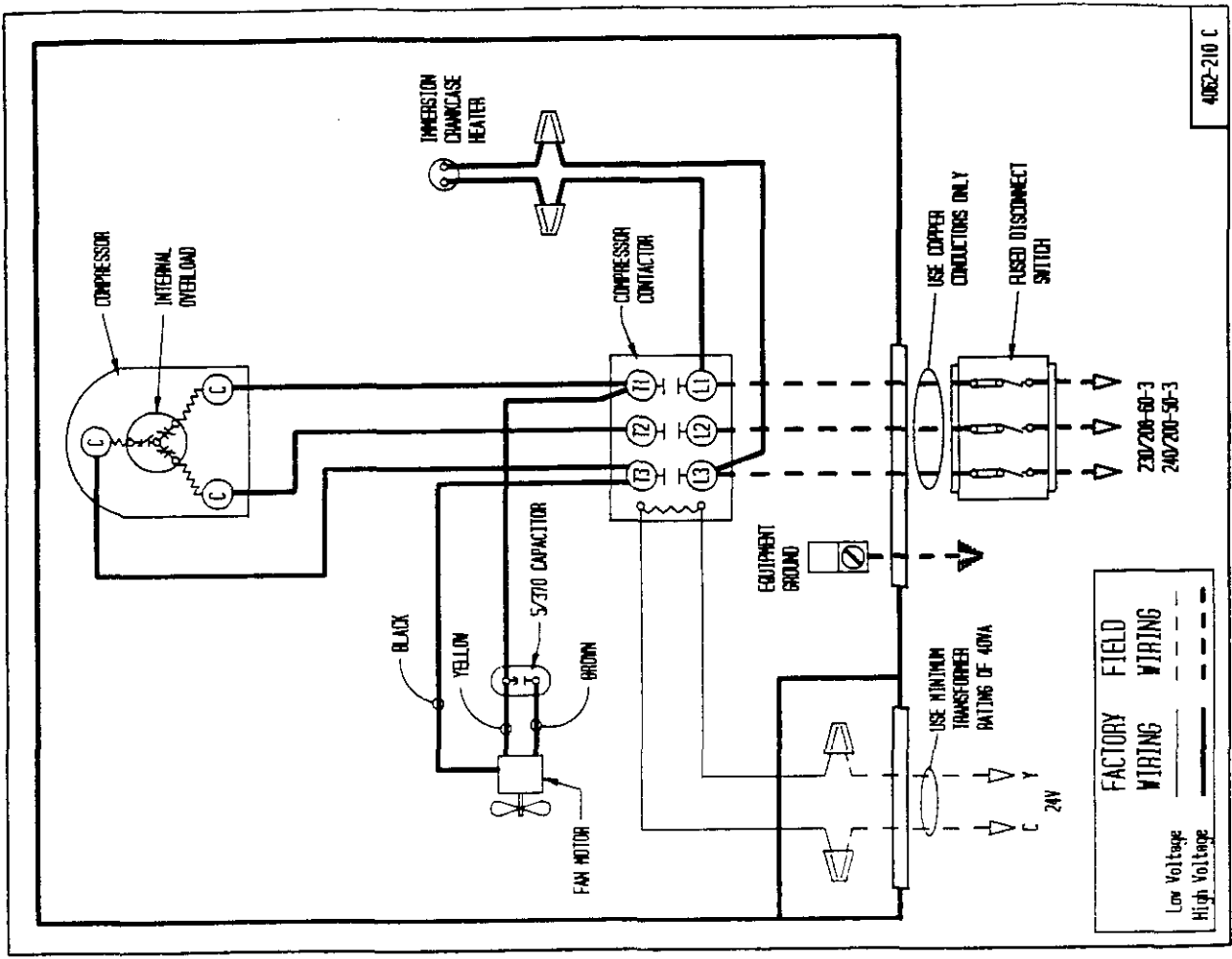

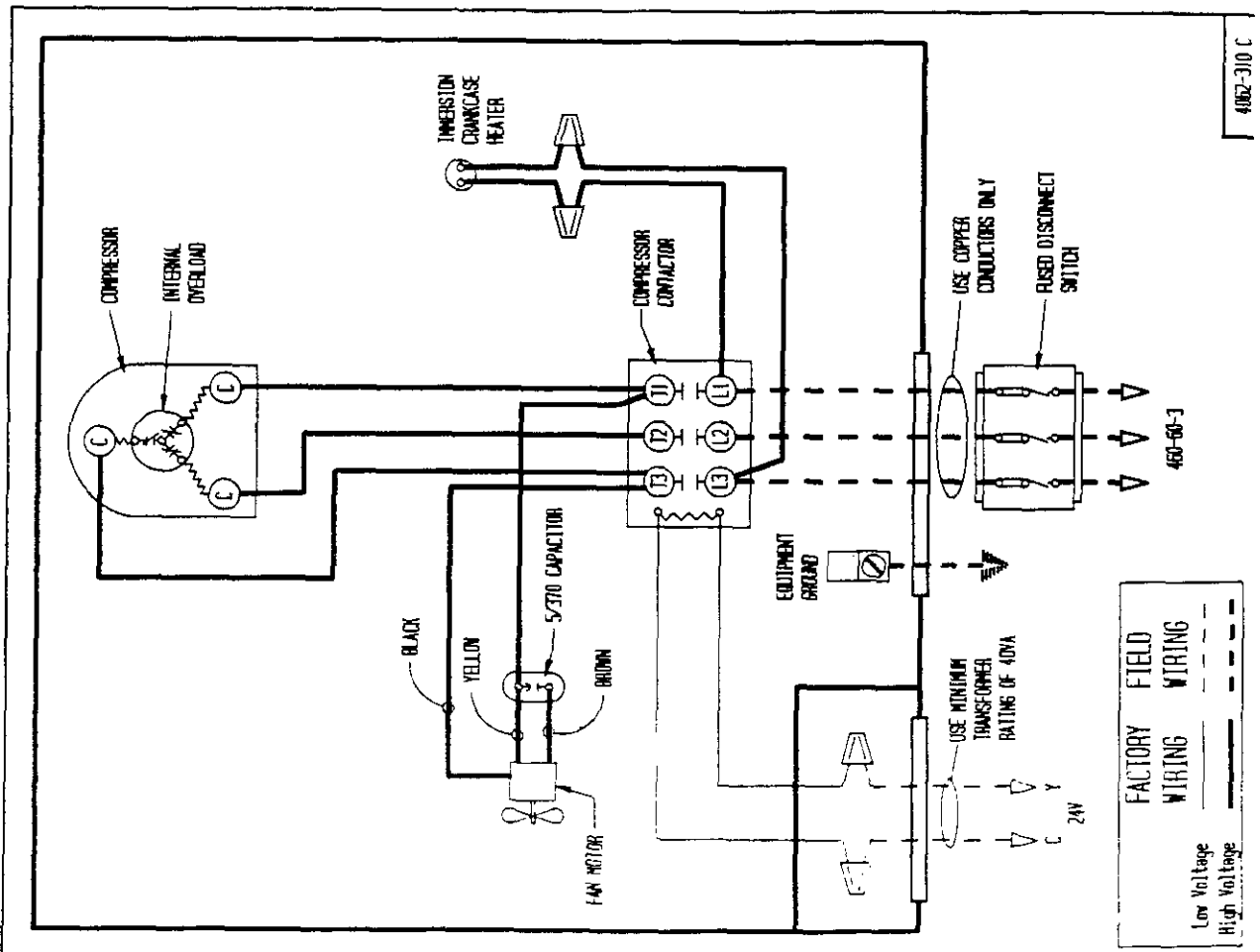
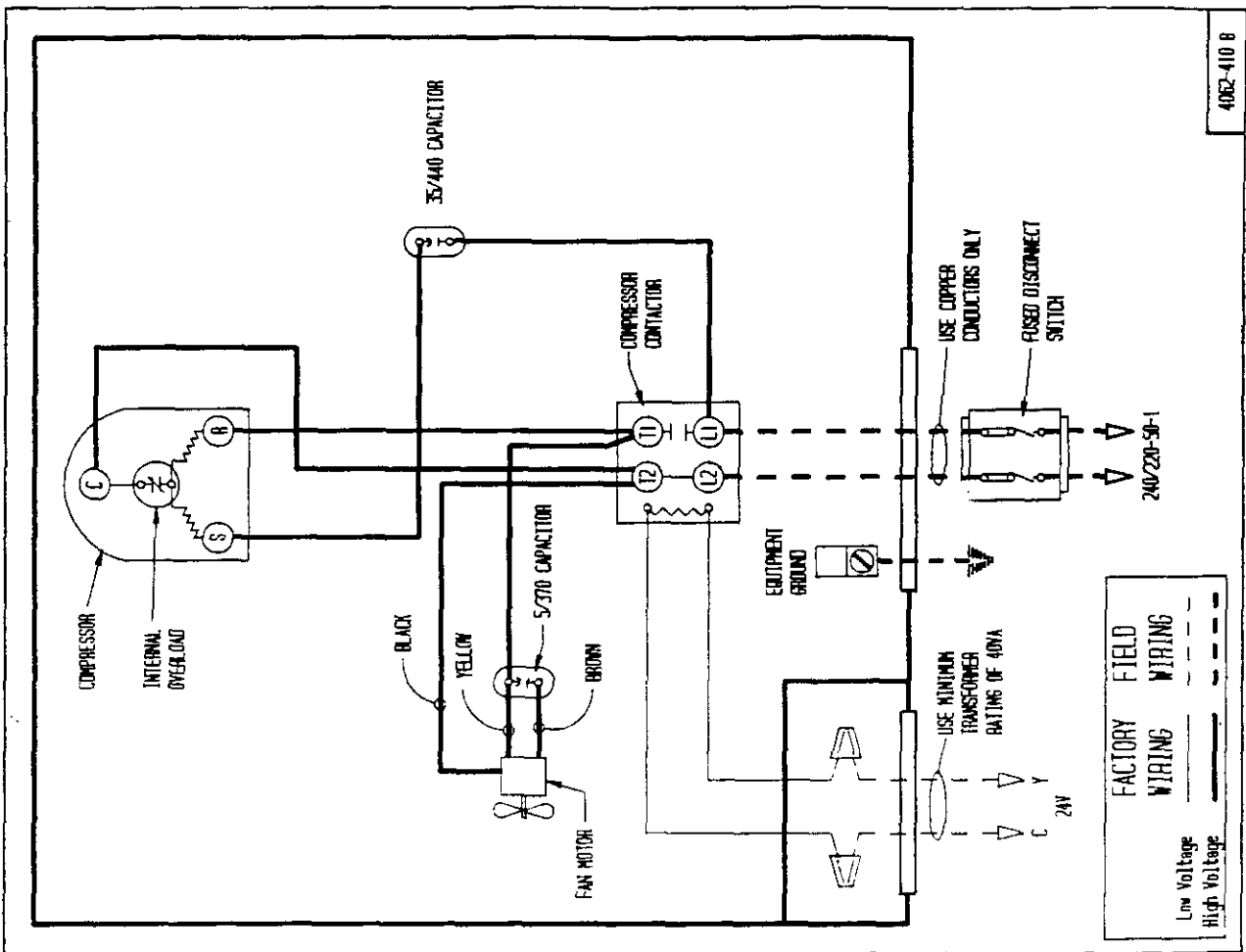

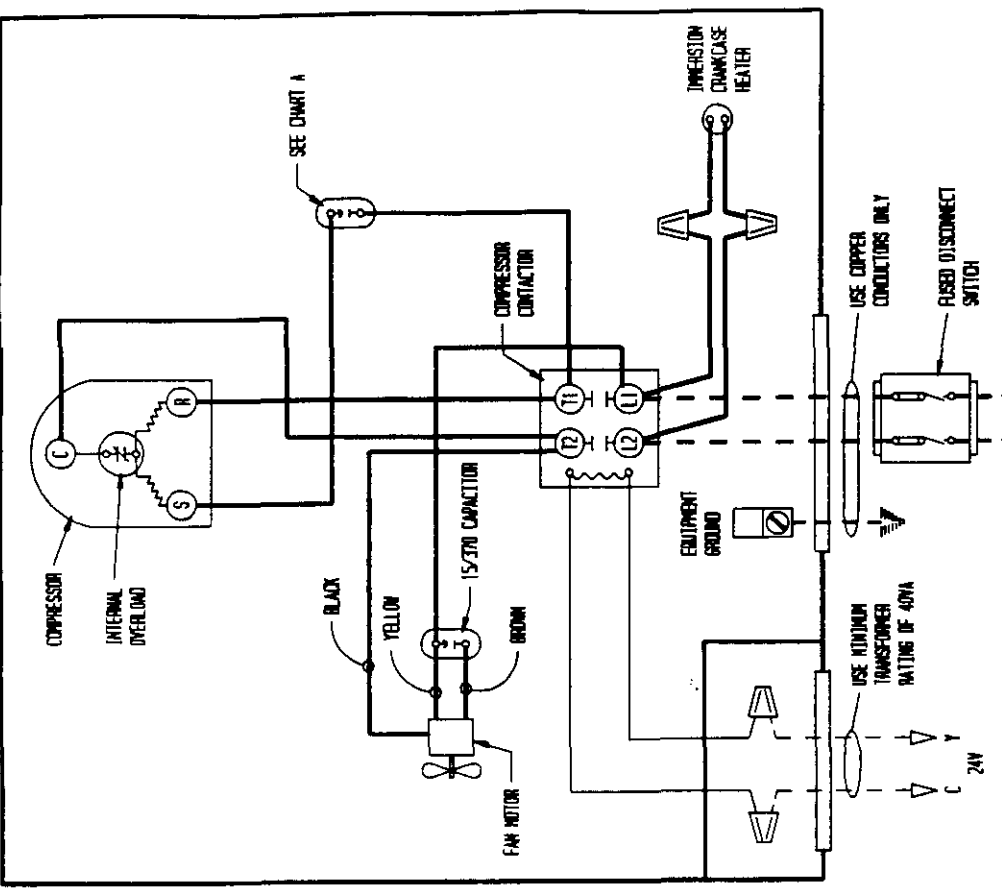
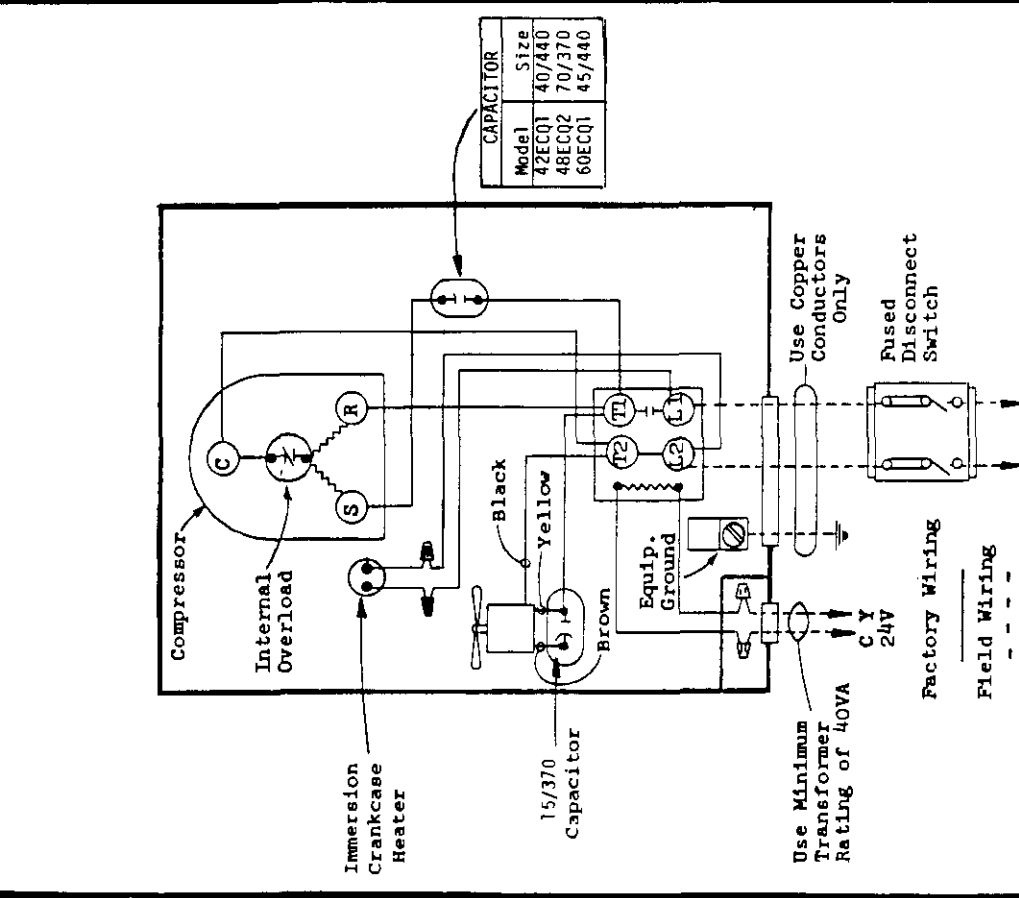

CHART A		
UNIT SIZE	CAP. SIZE	SIZE
3 1/2 TON	40/440	
4 TON	70/370	
5 TON	45/440	

Low Voltage
High Voltage

FACTORY WIRING
FIELD WIRING



CAPACITOR	
Model	Size
42ECQ1	40/440
48ECQ2	70/370
60ECQ1	45/440

