

INSTALLATION INSTRUCTIONS

MODELS

18ECQ2	31ECQ1	42ECQ1
18ECS2	31ECS1	42ECS1
24ECQ4	36ECQ5	48ECQ2
24ECS4	36ECS5	48ECS2
30ECQ4	37ECQ1	60ECQ1
30ECS4	37ECS1	60ECS1

SPLIT AIR CONDITIONER
OUTDOOR SECTION

FOR USE WITH:
MATCHING INDOOR BLOWER
COIL UNITS AND MATCHING
ADD ON COIL UNITS ONLY

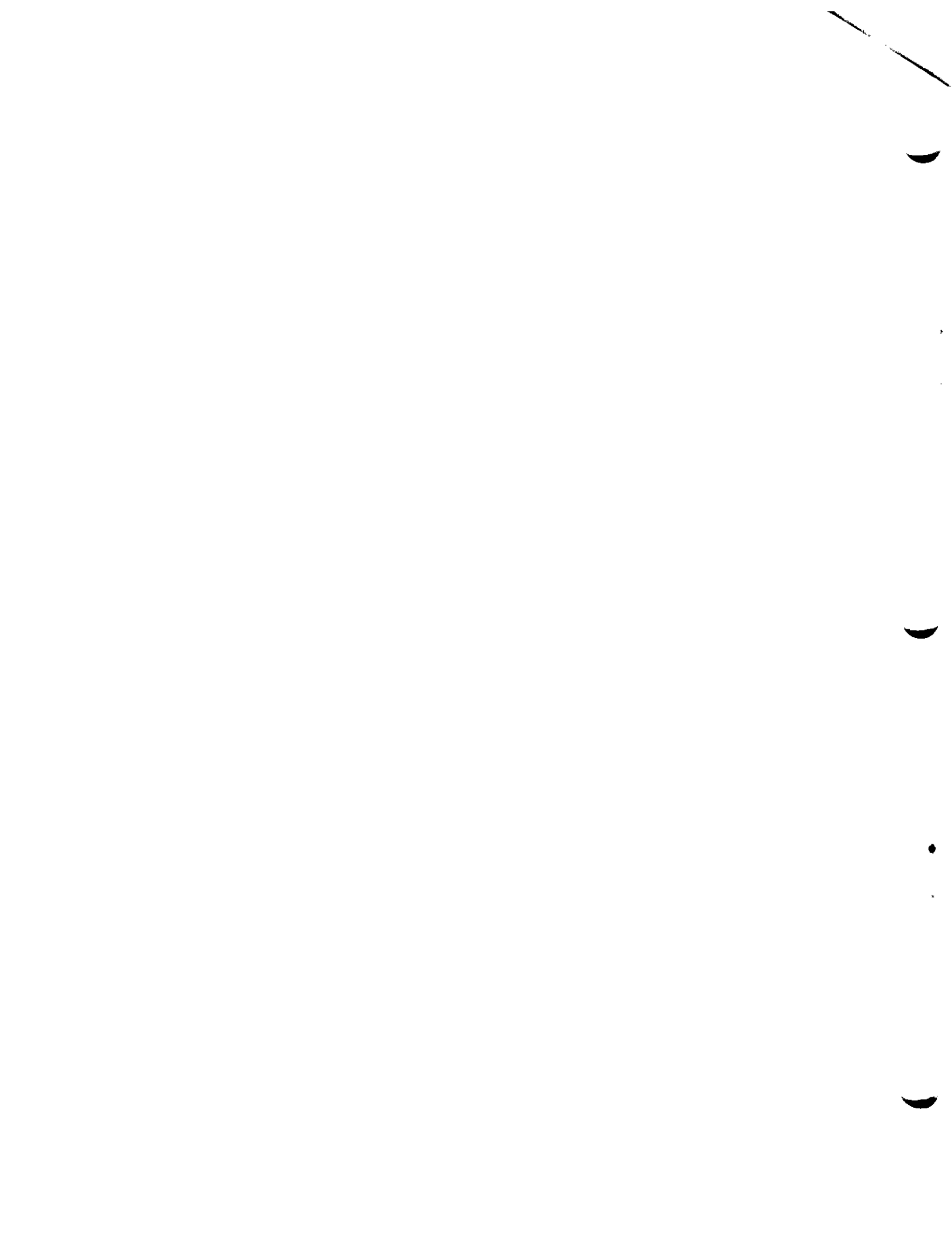

APPLICATION AND INSTALLATION INSTRUCTIONS

GENERAL

These instructions explain the recommended method to install the pre-charged air cooled remote type condensing unit, the inter-connecting refrigerant tubing and the electrical wiring connections to the unit.

The condensing units are to be used in conjunction with the matching evaporator coil for comfort cooling applications as shown in the specification sheet.

These instructions and any instructions packaged with any separate equipment required to make up the entire air conditioning system should be carefully read before beginning the installation. Note particularly "Starting Procedure" and any tags and/or labels attached to the equipment.

While these instructions are intended as a general recommended guide, they do not supersede any national and/or local codes in any way. Authorities having jurisdiction should be consulted before the installation is made.

SHIPPING DAMAGE

Upon receipt of equipment, the carton should be checked for external signs of shipping damage. If damage is found, the receiving party must contact the last carrier immediately, preferably in writing, requesting inspection by the carrier's agent.

INSTALLATION

Size of unit for a proposed installation should be based on heat loss calculation made according to methods of National Warm Air Heating and Air Conditioning Association. The air duct should be installed in accordance with the Standards of the National Fire Protection Association for the Installation of Air Conditioning and Ventilating Systems of Other Than Residence Type, NFPA No. 90A, and Residence Type Warm Air Heating and Air Conditioning Systems, NFPA No. 90B. Where local regulations are at a variance with instructions, installer should adhere to local codes.

LOCATION

The condensing unit (outdoor unit) must be located in an area having good air circulation and set where the hot discharge air from the unit will not be recirculated into the condensing coil. Figure 1 illustrates the recommended clearances for unrestricted airflow and service access.

MOUNTING UNIT OUTSIDE ON SLAB

A solid level base or platform, capable to support the unit's weight, must be set at the outdoor unit predetermined location. The base should be at least two inches larger than the base dimensions of the unit and at least two inches higher than the surrounding grade level. The required unit minimum installed clearances must be maintained as called out in Figure 1 when locating and setting the base.

Remove the unit from its shipping carton and position the unit on the prepared base or platform.

Do not attach the unit or its base to the building structure to avoid the transmission of noise into the occupied area.

NOTE: These units employ internally sprung compressors; therefore, it is not necessary to remove or loosen the base mounting bolts on the compressor prior to operation.

Consideration should be given to the electrical and tubing connections when placing the unit to avoid unnecessary bends or length of material.

WIRING

All wiring must be installed in accordance with the National Electrical Code and local codes. Power supply voltage must conform to the voltage shown on the unit serial plate. A wiring diagram of the unit is attached to the inside of the electrical cover. The power supply shall be sized and fused according to the specifications supplied. A ground lug is supplied in the control compartment for equipment ground.

The control circuit is a 24 volt circuit. "Typical" wiring diagrams illustrating some of the various circuits which could be encountered can be found later in the manual.

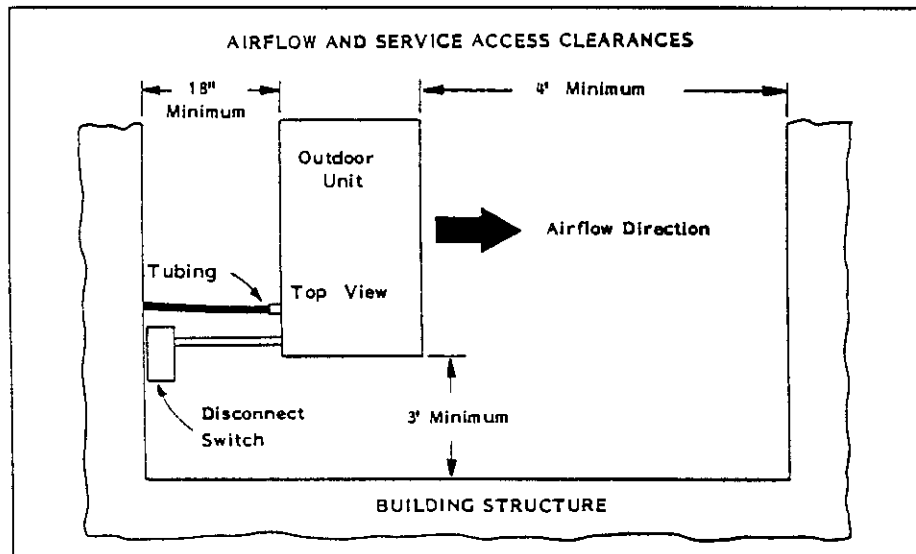

FIGURE 1.

The unit rating plate lists a "Maximum Time Delay Fuse" or "HACR Type" circuit breaker that is to be used with the equipment. The correct size must be used for proper circuit protection and also to assure that there will be no nuisance tripping due to the momentary high starting current of the compressor motor.

When matching with a B-model blower coil unit, refer to the installation instructions with that indoor unit for 24V wiring information.

PRESSURE SERVICE PORTS

High and low pressure service ports are installed on all units so that the system operating pressures can be observed. Pressure curves can be found later in the manual covering all models. It is imperative to match the correct pressure curve to the unit by model number.

The pressure service ports on the split system air conditioners are located on the inter-connecting tubing quick connect fittings or base valves.

CRANKCASE HEATERS

All units are provided with some form of compressor crankcase heat. Some single phase units utilize the compressor motor start winding in series with a portion of the run capacitor to generate heat within the compressor shell to prevent liquid refrigerant migration.

Some three phase units utilize a wraparound type of crankcase heater that warms the compressor oil from the outside.

Some single and three phase models have an insertion well-type heater located in the lower section of the compressor housing. This is a self-regulating type heater that draws only enough power to maintain the compressor at a safe temperature.

Some form of crankcase heat is essential to prevent liquid refrigerant from migrating to the compressor, causing oil pump out on compressor start-up and possible valve failure due to compressing a liquid.

Refer to unit wiring diagram to find exact type of crankcase heater used.

The following decal is affixed to all outdoor units detailing start-up procedure. This is very important. Please read carefully.

IMPORTANT

THESE PROCEDURES MUST BE FOLLOWED AT INITIAL START-UP AND AT ANY TIME POWER HAS BEEN REMOVED FOR 12 HOURS OR LONGER.

TO PREVENT COMPRESSOR DAMAGE WHICH MAY RESULT FROM THE PRESENCE OF LIQUID REFRIGERANT IN THE COMPRESSOR CRANKCASE

1. MAKE CERTAIN THE ROOM THERMOSTAT IS IN THE OFF POSITION (THE COMPRESSOR IS NOT TO OPERATE).
2. APPLY POWER BY CLOSING THE SYSTEM DISCONNECT SWITCH THIS ENERGIZES THE COMPRESSOR HEATER WHICH EVAPORATES THE LIQUID REFRIGERANT IN THE CRANKCASE.
3. ALLOW 4 HOURS OR 80 MINUTES PER POUND OF REFRIGERANT IN THE SYSTEM AS NOTED ON THE UNIT RATING PLATE WHICHEVER IS GREATER.
4. AFTER PROPERLY ELAPSED TIME THE THERMOSTAT MAY BE SET TO OPERATE THE COMPRESSOR.
5. EXCEPT AS REQUIRED FOR SAFETY WHILE SERVICING - DO NOT OPEN SYSTEM DISCONNECT SWITCH.

7961 061

FAN BLADE SETTING DIMENSIONS

Shown in the drawing below are the correct fan blade setting dimensions for proper air delivery across the outdoor coil.

Any service work requiring removal or adjustment in the fan and/or motor area will require that the dimensions below be checked and blade adjusted in or out on the motor shaft accordingly.

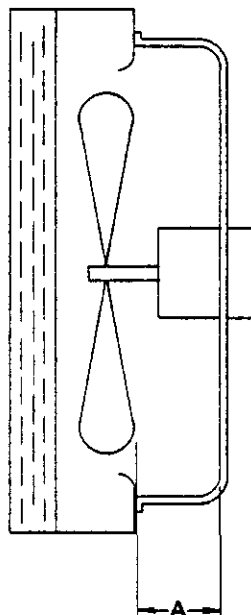

MODEL	DIM. A
All	1/2"

IMPORTANT INSTALLER NOTE:

For improved start-up performance, wash the indoor coil with a dishwasher detergent.

ELECTRICAL DATA							
Model	Electrical Rating	Operating Voltage Range	Total Unit Amps ^①	Minimum Circuit Ampacity	Maximum ^② Overcurrent Protection	60°C Copper Wire Size	Copper Ground Wire Size
18ECQ,S2	230/208-60-1	197-253	11.6	15	20	#14	#14
24ECQ,S4	230/208-60-1	197-253	12.1	15	25	#14	#14
30ECQ,S4	230/208-60-1	197-253	16	22	35	#10	#10
31ECQ,S1	230/208-60-1	197-253	15	20	35	#12	#12
36ECQ,S5	230/208-60-1	197-253	22	29	50	#10	#10
37ECQ,S1	230/208-60-1	197-253	19	26	40	#10	#10
	230/208-60-3	187-253	13	18	30	#12	#12
	460-60-3	414-506	7.7	15	20	#14	#14
42ECQ,S1	230/208-60-1	197-253	24.3	30	50	#10	#10
	230/208-60-3	187-253	16.8	21	30	#10	#10
	460-60-3	414-506	9.4	15	20	#14	#14
48ECQ,S2	230/208-60-1	197-253	25.8	32	50	#8	#10
	230/208-60-3	187-253	19.3	24	35	#10	#10
	460-60-3	414-506	11.4	16	25	#12	#12
60ECQ,S1	230/208-60-1	197-253	31.8	39	60	#8	#10
	230/208-60-3	187-253	22.8	28	45	#10	#10
	460-60-3	414-506	9.2	15	15	#14	#14

① Compressor and outdoor motor. ② Time Delay Fuse or HACR Type Circuit Breaker.

If this unit is operated in cooling below a 65° outdoor ambient temperature, the installation of low ambient control (LAC-1) to unit is required.

REFRIGERANT CHARGE

To obtain maximum rated capacity and efficiency, the system charge may have to be adjusted at installation to obtain a suction line temperature (6" from compressor) as shown in the following table.

Outdoor Unit	Indoor Unit	95°F O.D. Temp.	82°F O.D. Temp.
18ECQ, S2	18QS3 2ACQ1 B18EHQ1 B24EHQ1	55 - 57 48 - 50 58 - 60 58 - 60	65 - 67 57 - 59 63 - 65 62 - 64
24ECQ, S4	24QS1 2ACQ1 B24EHQ1 B18EHQ1	50 - 52 44 - 46 50 - 52 50 - 52	56 - 58 50 - 52 56 - 58 56 - 58
30ECQ, S4	3ACQ3 3HCQ1 B36EHQ1 B30EHQ	48 - 50 52 - 54 52 - 54 54 - 56	60 - 62 64 - 66 63 - 65 58 - 60
31ECQ, S1	3ACQ3 3HCQ1 B36EHQ1 B30EHQ	48 - 50 54 - 56 50 - 52 46 - 48	52 - 54 67 - 69 61 - 63 57 - 59
36ECQ, S5	3ACQ3 3HCQ1 B36EHQ1	52 - 54 56 - 58 52 - 54	60 - 62 63 - 65 63 - 65
37ECQ, S1	3ACQ3 3HCQ1 B36EHQ1	45 - 47 55 - 57 52 - 54	55 - 57 65 - 67 63 - 65
42ECQ, S1	4ACQ2 5ACQ1 4HCQ BC48A	47 - 49 50 - 52 55 - 57 51 - 53	59 - 61 53 - 55 63 - 65 55 - 57
48ECQ, S2	4ACQ2 5ACQ1 4HCQ BC48A	52 - 54 50 - 52 56 - 58 53 - 55	62 - 64 52 - 54 66 - 68 60 - 62
60ECQ, S1	5ACQ1 5HCQ BC48A BC60A	50 - 52 49 - 51 55 - 57 48 - 50	59 - 61 58 - 60 63 - 65 58 - 60

The above suction line temperatures are based upon 80°F dry bulb/67° wet bulb (50% R.H.) temperature and rated airflow across the evaporator during cooling cycle.

TABLE 2

RATED CFM AND AIRFLOW DATA (WET COIL — COOLING)

Outdoor Unit Model	Indoor Coil Model	Rated CFM	Pressure Drop in H ₂ O (1)	Rated E.S.P. (2)	Recommended Air Flow Range
18ECQ, S2	18QS3	600	.30		540 - 660
	2ACQ1	640	.20		575 - 705
	B18EHQ1	650		.30	585 - 715
	B24EHQ1	650		.30	585 - 715
24ECQ, S4	24QS1	870	.30		780 - 960
	2ACQ1	870	.30		780 - 960
	B24EHQ1	800		.10	720 - 880
	B18EHQ1	800		.10	720 - 880
30ECQ, S4	3ACQ3	1100	.28		990 - 1210
	3HCQ1	1035	.30		900 - 1150
	B36EHQ1	1050		.50 (3)	945 - 1155
	B30EHQ	800		.10	720 - 880
31ECQ, S1	3ACQ3	1050	.25		940 - 1160
	3HCQ1	1035	.30		900 - 1150
	B36EHQ1	1000		.55 (3)	900 - 1150
	B30EHQ	800		.10	720 - 880
36ECQ, S5	3ACQ3	1180	.30		1060 - 1300
	3HCQ1	1000	.30		900 - 1100
	B36EHQ1	1275		.40	1150 - 1400
37ECQ, S1	3ACQ3	1180	.30		1060 - 1300
	3HCQ1	1000	.30		900 - 1100
	B36EHQ1	1200		.50	1080 - 1320
42ECQ, S1	4ACQ2	1450	.25		1300 - 1600
	5ACQ1	1600	.14		1440 - 1760
	4HCQ	1500	.30		1350 - 1650
	BC48A	1575		.40	1420 - 1730
48ECQ, S2	4ACQ2	1690	.30		1520 - 1860
	5ACQ1	1800	.18		1620 - 1980
	4HCQ	1600	.30		1440 - 1760
	BC48A	1725		.30	1550 - 1900
60ECQ, S1	5ACQ1	1990	.28		1790 - 2190
	5HCQ	1650	.30		1485 - 1815
	BC48A	1625		.30	1460 - 1790
	BC60A	1800		.30	1590 - 1950

(1) Measured across the evaporator coil assembly, including drain pan.

(2) External static pressure available for the duct system—supply and return. All blower coil models have multi-speed motors, and value shown is at recommended speed. Consult specification airflow charts for complete information as to other speeds available.

(3) Rated external static pressure on low speed.

TABLE 1

INSTALLING REFRIGERANT TUBING

(PRE-CHARGED - Applicable to "Q" Models)

PRE-CHARGED TUBING - Examine carefully the two lengths of pre-charged tubing furnished with the unit. The larger is the suction line. The smaller is the liquid line. The end of the tubing with the hex nut and gauge port is to be attached to the condensing unit.

Unroll the tubing, being careful not to kink, and install it between the condensing unit and the evaporator coil.

CAUTION: Be careful not to tear the insulation when pushing it through holes in masonry or frame walls.

When sealing tube opening in house wall use a soft material to prevent tube damage and vibration transmission.

Before fastening either end, use a tubing bender to make any necessary bends in the tubing. **AVOID EXCESSIVE BENDING IN ANY ONE PLACE TO AVOID KINKING.**

Start connecting the tubing at the evaporator coil end, first remove the protective caps and plugs from the quick-connect fittings on the evaporator coil and the pre-charged tubing. Inspect fittings and clean if necessary, making sure they are clear of foreign materials. If you clean the fittings, lubricate them with refrigeration oil. Connect both tubes to the fittings on the coil and draw up by hand.

When necessary to bend the insulated tube, suction line, cut the insulation around its circumference at a distance far enough beyond the point of the bend so as to clear the tubing bender.

Slip the insulation back together and vapor seal the joint with tape.

NOTE: The maximum distance for pre-charge tubing between the condenser and the evaporator is 45 feet.

CAUTION: Prior to connecting the pre-charged tubing to the evaporator coil or condensing unit, be sure all bends have been made, then coil any excess tubing in a horizontal plane, with the slope of the tubing toward the condensing unit.

CAUTION: Be sure to hold the coupling firmly to prevent movement of the coupling and tubing. Failure to do so could tear out the diaphragm causing a blockage of the system.

CAUTION: After starting to tighten up the fitting never try to back it off or take it apart.

For connecting the tubing at the condensing unit end, first remove the protective caps and plugs from the quick-connect fittings on the condensing unit and the pre-charged tubing. Inspect fittings and clean if necessary, making sure they are clear of foreign materials. If you clean the fittings, lubricate them with refrigeration oil. Connect both tubes to the fittings on the coil and draw up by hand.

Locate the gauge port in a 45° angle from a vertical up position so as to be accessible for gauge connections.

Use a wrench on the hex nut of the female fitting backing up the fitting with another wrench to keep tube from turning. Tighten the fittings together until they bottom out then tighten for an additional 1/4 turn so that coupling will seat properly.

Check the gauge port cap to make sure it is tight. If loose, tighten, being careful not to tighten too much as it will damage the valve in the gauge port.

Leak test all connections using an Electronic Leak Detector or a Halide Torch.

When tubing is installed in attics or drop ceiling, insulate the quick connect fitting on the larger tube thoroughly with 3/8" wall thickness, closed cell sponge tube insulation or equivalent. Failure to insulate will result in water damage to ceiling since the fitting will "sweat" and drop water on the ceiling.

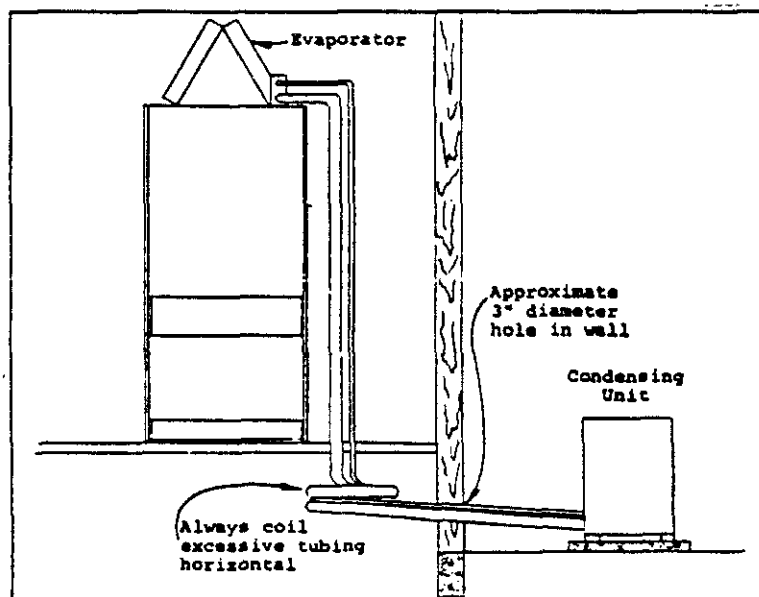

INSTALLING REFRIGERANT TUBING

(Applicable to "S" models)

Use only refrigeration grade (dehydrated and sealed) copper tubing of the size indicated below. Care must be taken to insure that the tubing is kept clean and dry before and during installation. DO NOT remove the plugs from the tubing ends, coil connections or base valves until the connection is ready to be made.

Insulate the suction line with a minimum of 3/8" Armaflex or equivalent. Install the insulation to the suction line before cutting and making connections.

When connecting to an indoor coil which has quick connect fittings, a CTO-A or CTO-12A stub kit is required. See chart on Total System Operating Charge.

Basic Condensing Unit Model	REFRIGERANT LINE LENGTH (Ft.)		
	0-20	21-60	61-100
	Liq. & Suct.	Liq. & Suct.	Liq. & Suct.
18 or 24ECS	3/8 & 5/8	3/8 & 5/8	3/8 & 3/4
30ECS	3/8 & 5/8	3/8 & 3/4	3/8 & 3/4
36ECS	3/8 & 5/8	3/8 & 3/4	1/2 & 7/8
42ECS	3/8 & 3/4	3/8 & 7/8	1/2 & 7/8
48ECS	3/8 & 7/8	3/8 & 7/8	1/2 & 1-1/8
60ECS	3/8 & 7/8	3/8 & 7/8	1/2 & 1-1/8

NOTE: The outdoor unit on the "S" models has the full operating charge for the most frequently used combination of outdoor to indoor section. First, discharge the small holding charge in the indoor coil, then connect the tubing to the indoor coil and to the base valves of the outdoor unit. Leak test and evacuate the coil and tubing before opening the base valves. After operating the system, check and adjust the R-22 charge as shown under "Refrigerant Charge", Table 2, on page 3.

TYPICAL APPLICATION — GAS FURNACE WITH SINGLE SPEED MOTOR

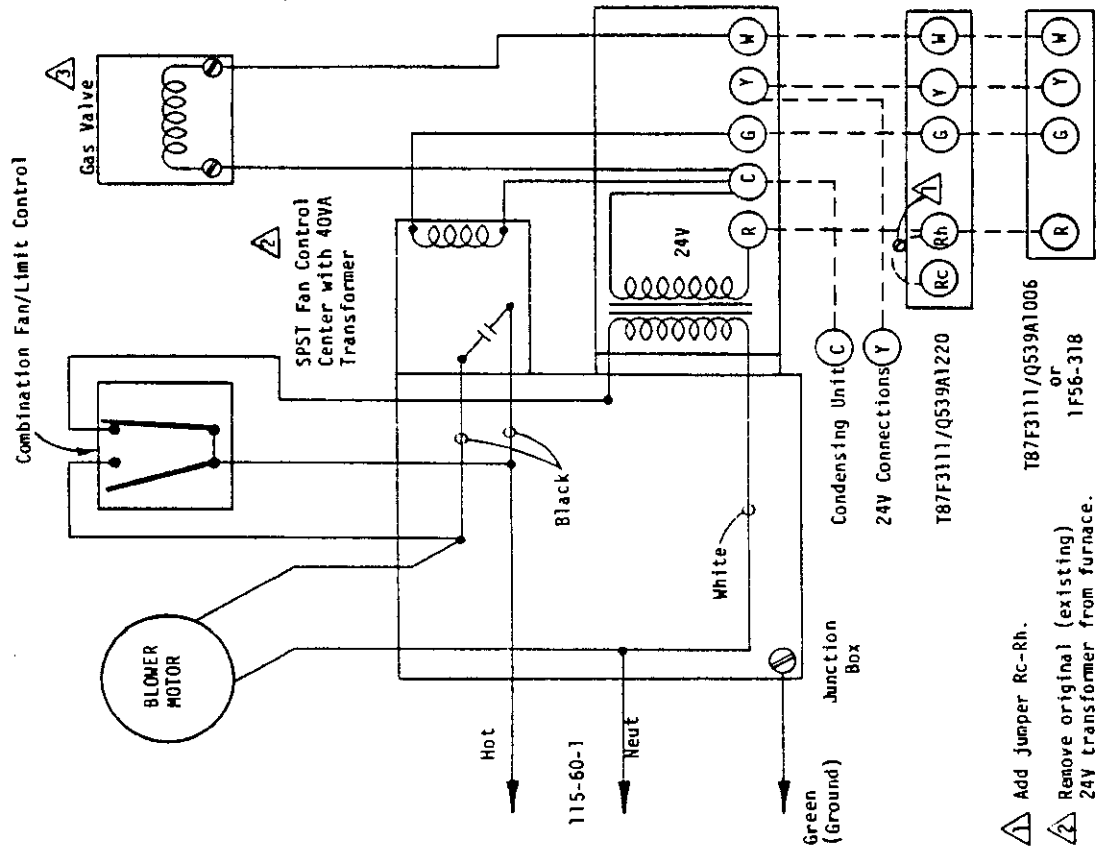

- ⚠ Add jumper Rc-Rh.
- ⚠ Remove original (existing) 24V transformer from furnace.
- ⚠ Gas valve current draw should be observed and thermostat heat anticipator set at a corresponding value.

4051-110

TYPICAL APPLICATION — GAS FURNACE WITH MULTI-SPEED MOTOR

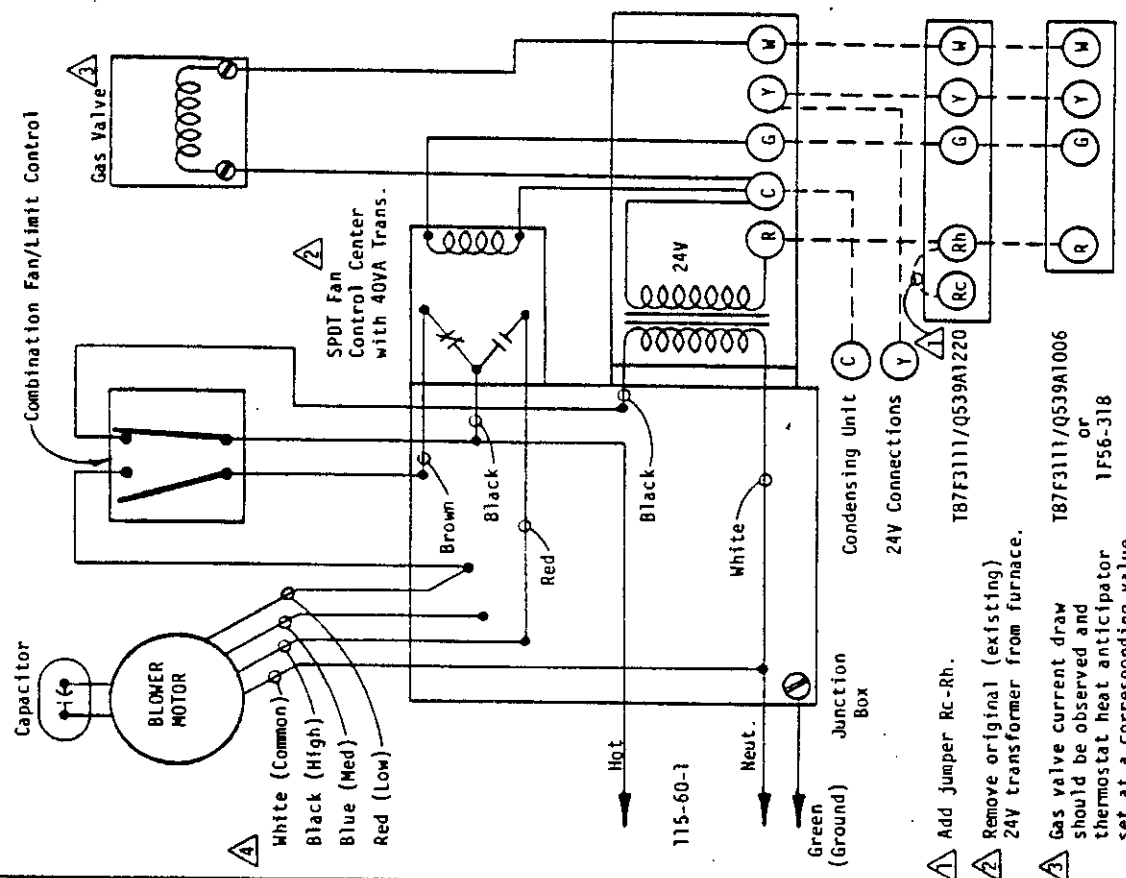

- ⚠ Add jumper Rc-Rh.
- ⚠ Remove original (existing) 24V transformer from furnace.
- ⚠ Gas valve current draw should be observed and thermostat heat anticipator set at a corresponding value.
- ⚠ Any combination of speeds can be used. Be sure to connect only one speed to any one point and that all unused speeds are taped off separately.

4051-120

TYPICAL APPLICATION — OIL FURNACE

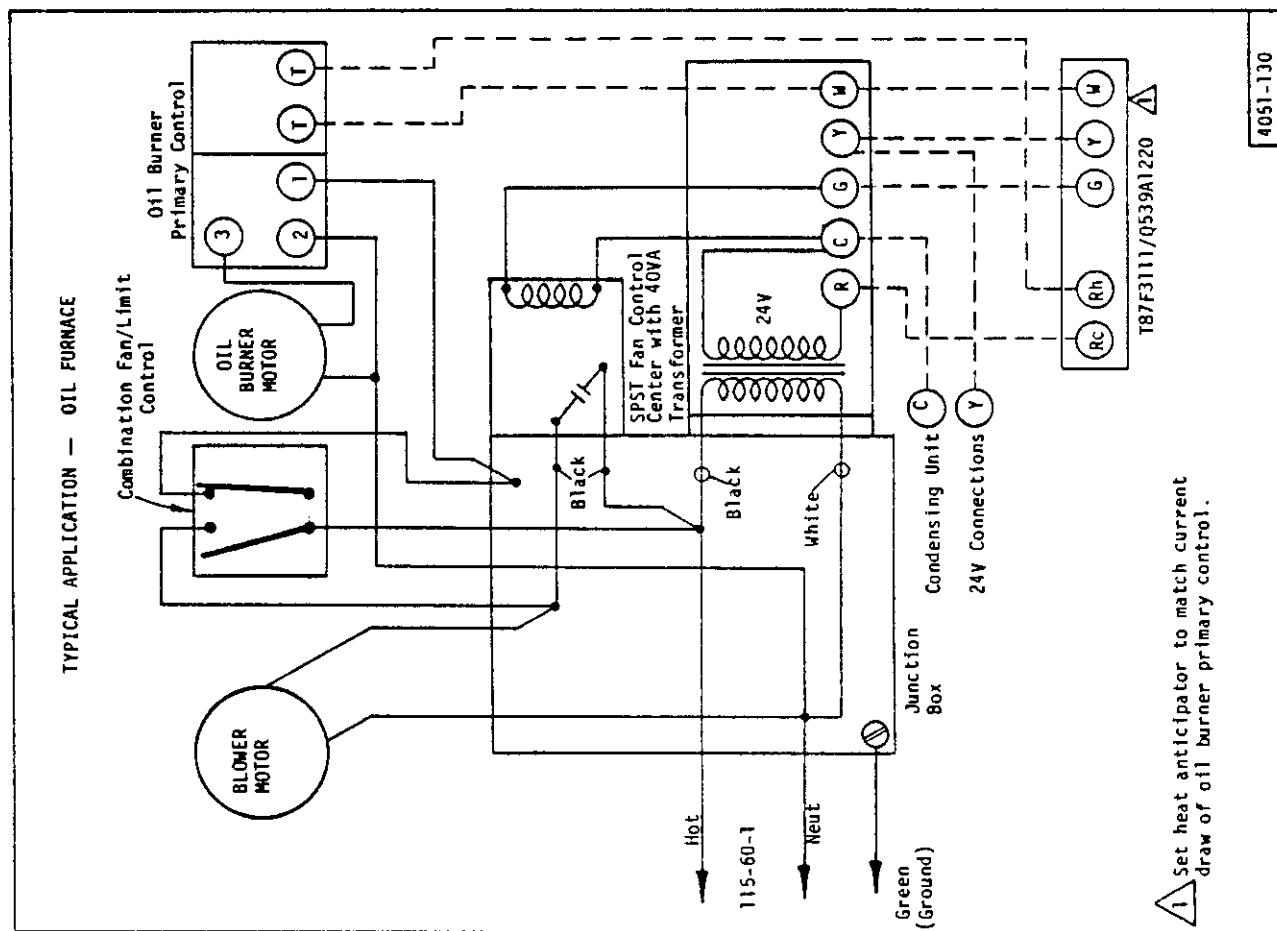

1 Set heat anticipator to match current draw of oil burner primary control.

PARTS LIST
SPLIT SYSTEM CONDENSING UNITS

Part No.	Description	18ECQ, S2	24ECQ, S4	30ECQ, S4	31ECQ, S1	36ECQ, S5	37ECQ, S1	37ECQ1-B	42ECQ, S1	42ECQ1-B	48ECQ, S2	48ECQ2-B	60ECQ, S1	60ECQ1-B	37ECQ1-C 460V	42ECQ1-C 460V	48ECQ2-C 460V	60ECQ1-C 460V	
8552-044	Capacitor 15/10-370V	x																	
8552-007	Capacitor 20/15-370V		x	x	x														
8552-030	Capacitor 40/440V					x			x										
8552-036	Capacitor 70/370V										x								
8552-031	Capacitor 45/440V						x						x						
8552-026	Capacitor 15/370V								x	x	x	x	x	x		x	x		x
8552-002	Capacitor 5/370V	x	x	x	x	x	x								x				
8000-061	Compressor RES3-0175-PFV	x																	
8000-071	Compressor AB225HT		x																
8000-080	Compressor AB233FT			x															
8000-070	Compressor AB233HT				x														
8000-072	Compressor AV144ET					x													
8000-084	Compressor AV135ET						x												
8000-059	Compressor CRJ3-0300-TF5							x											
8000-063	Compressor CRK3-0325-PFV								x										
8000-064	Compressor CRK3-0325-TF5									x									
8000-067	Compressor AG112ET										x								
8000-030	Compressor AG111RT											x							
8000-027	Compressor AG122ET												x						
8000-031	Compressor AG122RT													x					
8000-060	Compressor CRJ3-0300-TFD														x				
8000-065	Compressor CRK3-0325-TFD															x			
8000-047	Compressor AG111UT																x		
8000-048	Compressor AG122UT																	x	
5051-011	Condenser Coil	x																	
5051-013	Condenser Coil		x																
5051-034	Condenser Coil			x		x													
5051-035	Condenser Coil						x	x							x				
5051-009	Condenser Coil								x	x	x	x				x	x		
5051-024	Condenser Coil												x	x					x
5051-020	Condenser Coil				x														
8401-003	Contactora - Comp. 30A					x			x		x								
8401-002	Contactora - Comp. 25A							x		x		x		x	x	x	x		x
8401-016	Contactora - Comp. 35A												x						
8401-007	Contactora - Comp. 25A	x	x	x	x														
5151-001	Fan Blade TF1839	x	x																
5151-007	Fan Blade TP2029				x	x	x	x							x				
5151-017	Fan Blade FA2430-4B								x	x	x	x	x	x		x	x		x
8103-008	Motor - Fan 1/5 hp	x	x																
8103-009	Motor - Fan 1/5 hp			x	x	x	x	x											
8105-021	Motor - Fan 1/3 hp								x	x	x	x	x	x		x	x		x
8200-001	Motor Mount - Fan	x	x	x	x	x	x	x							x				x
8200-004	Motor Mount - Fan								x	x	x	x	x	x					x
8607-002	Terminal Block 230V														x				x
8407-003	Transformer - Stepdown															x			x
7051-010	Wire Grille - Inlet	x	x																
7051-009	Condenser Grille	x	x																
7051-003	Wire Grille - Inlet			x	x	x	x	x							x				
7051-001	Condenser Grille			x	x	x	x	x							x				
7051-004	Wire Grille - Inlet								x	x	x	x	x	x		x	x		
7051-005	Condenser Grille								x	x	x	x	x	x		x	x		x
8103-014	Motor - Fan 1/5 hp														x				

PARTS LIST
SPLIT SYSTEM CONDENSING UNITS

5/87

Part No.	Description	18ECQ,S2	24ECQ,S4	30ECQ,S4	31ECQ,S1	36ECQ,S5	37ECQ,S1	37ECQ1-B	42ECQ,S1	42ECQ1-B	48ECQ,S2	48ECQ2-B	60ECQ,S1	60ECQ1-B	37ECQ1-C 460V	42ECQ1-C 460V	48ECQ2-C 460V	60ECQ1-C 460V	
4021-110	Wiring Diagram	x	x																
4021-410	Wiring Diagram		x																
4025-120	Wiring Diagram								x		x		x						
4025-210	Wiring Diagram									x		x		x					
4025-310	Wiring Diagram															x			
4062-110	Wiring Diagram			x	x												x		x
4062-111	Wiring Diagram					x	x												
4062-210	Wiring Diagram							x											
4062-310	Wiring Diagram														x				
5651-051	Base Valve *	x	x	x	x	x	x		x		x		x						
5651-052	Base Valve *	x	x																
5651-053	Base Valve*			x	x	x	x												
5651-054	Base Valve *								x		x		x						

*Used only on "S" versions.

SPLIT AIR CONDITIONER
 MODEL 18EC*2 with 2ACQ1, B18EHQ1 and B24EHQ1 INDOOR COILS

5/87

These curves are based upon 80°DB, 67°WB R.A. Temp. and Rated CFM (airflow) across the evaporator coil and should be used for reference purposes only. Special information can be found under section titled "Refrigerant Charge" elsewhere in manual. If there is any doubt as to correct operating charge being in the system, the charge should be removed, system evacuated, and recharged according to serial plate instructions.

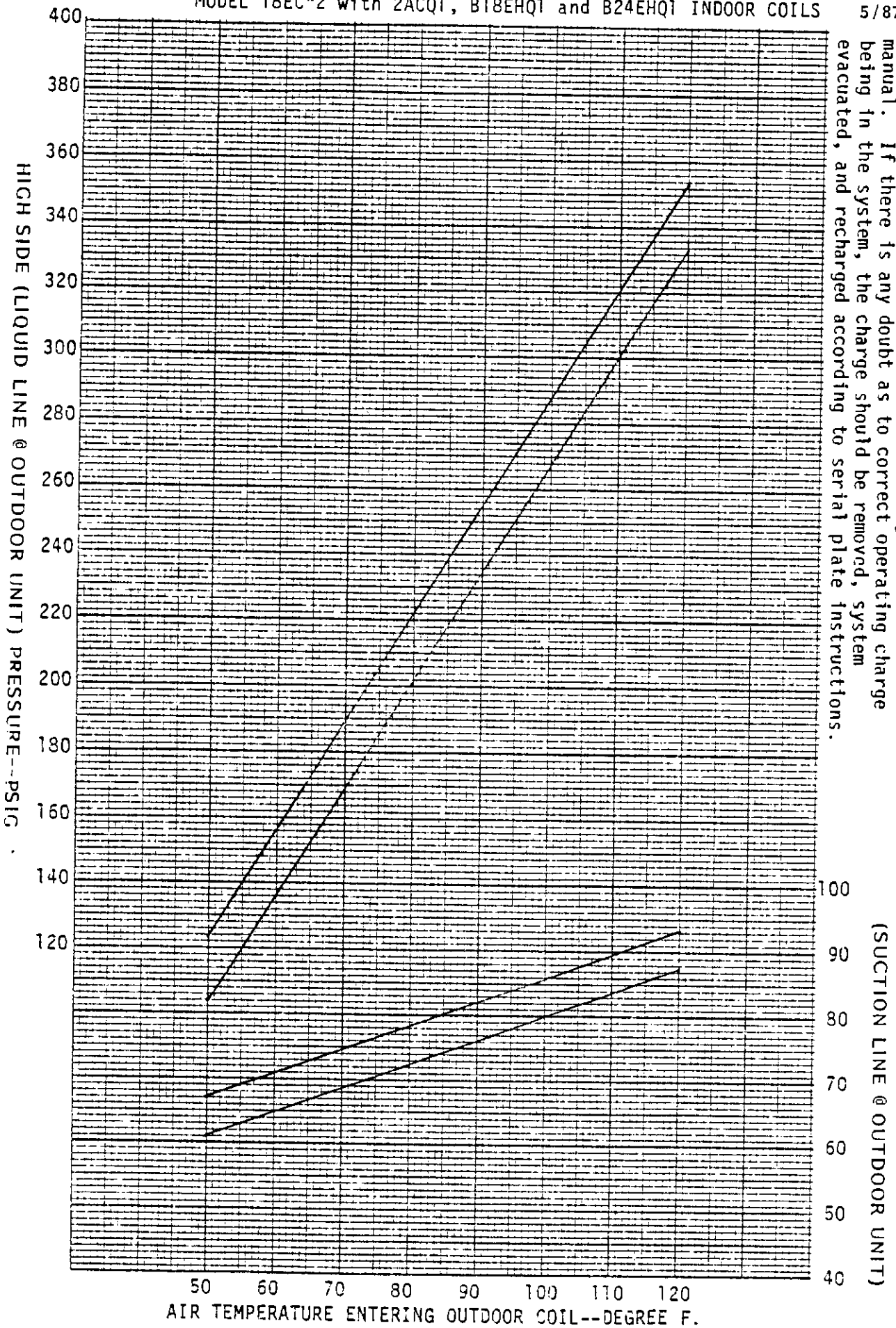

LOW SIDE PRESSURE--PSIG

HIGH SIDE (LIQUID LINE @ OUTDOOR UNIT) PRESSURE--PSIG

AIR TEMPERATURE ENTERING OUTDOOR COIL--DEGREE F.

(SUCTION LINE @ OUTDOOR UNIT)

SPLIT AIR CONDITIONER
 MODEL 18EC*2 with 18QS3 INDOOR COIL

5/87

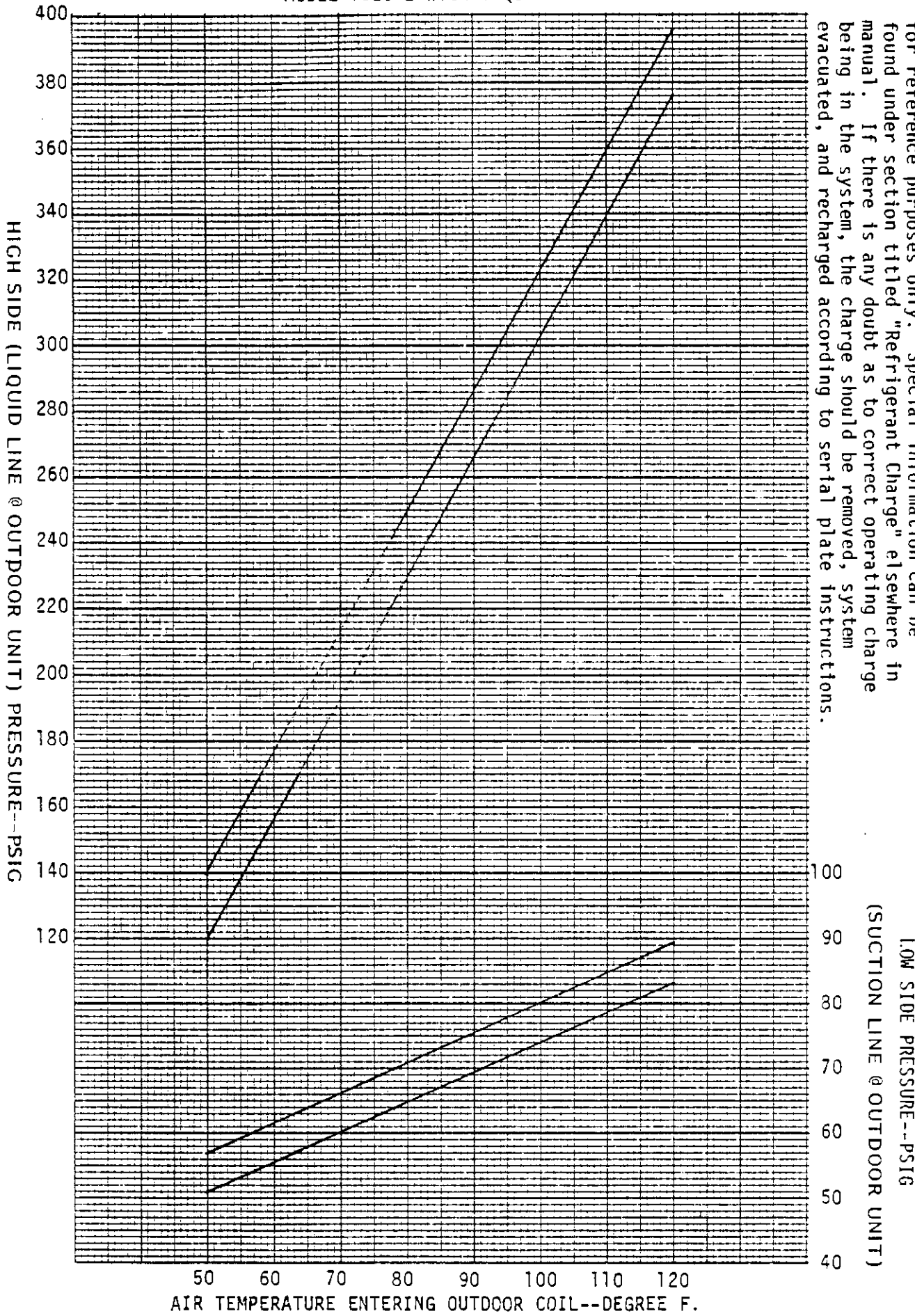

These curves are based upon 80°DB, 67°WB R.A. Temp. and Rated CFM (airflow) across the evaporator coil and should be used for reference purposes only. Special information can be found under section titled "Refrigerant Charge" elsewhere in manual. If there is any doubt as to correct operating charge being in the system, the charge should be removed, system evacuated, and recharged according to serial plate instructions.

LOW SIDE PRESSURE--PSIG
 (SUCTION LINE @ OUTDOOR UNIT)

HIGH SIDE (LIQUID LINE @ OUTDOOR UNIT) PRESSURE--PSIG

AIR TEMPERATURE ENTERING OUTDOOR COIL--DEGREE F.

SPLIT AIR CONDITIONER
 MODEL 24EC*4 with B18EHQ1 and 24QS1 INDOOR COILS

5/87

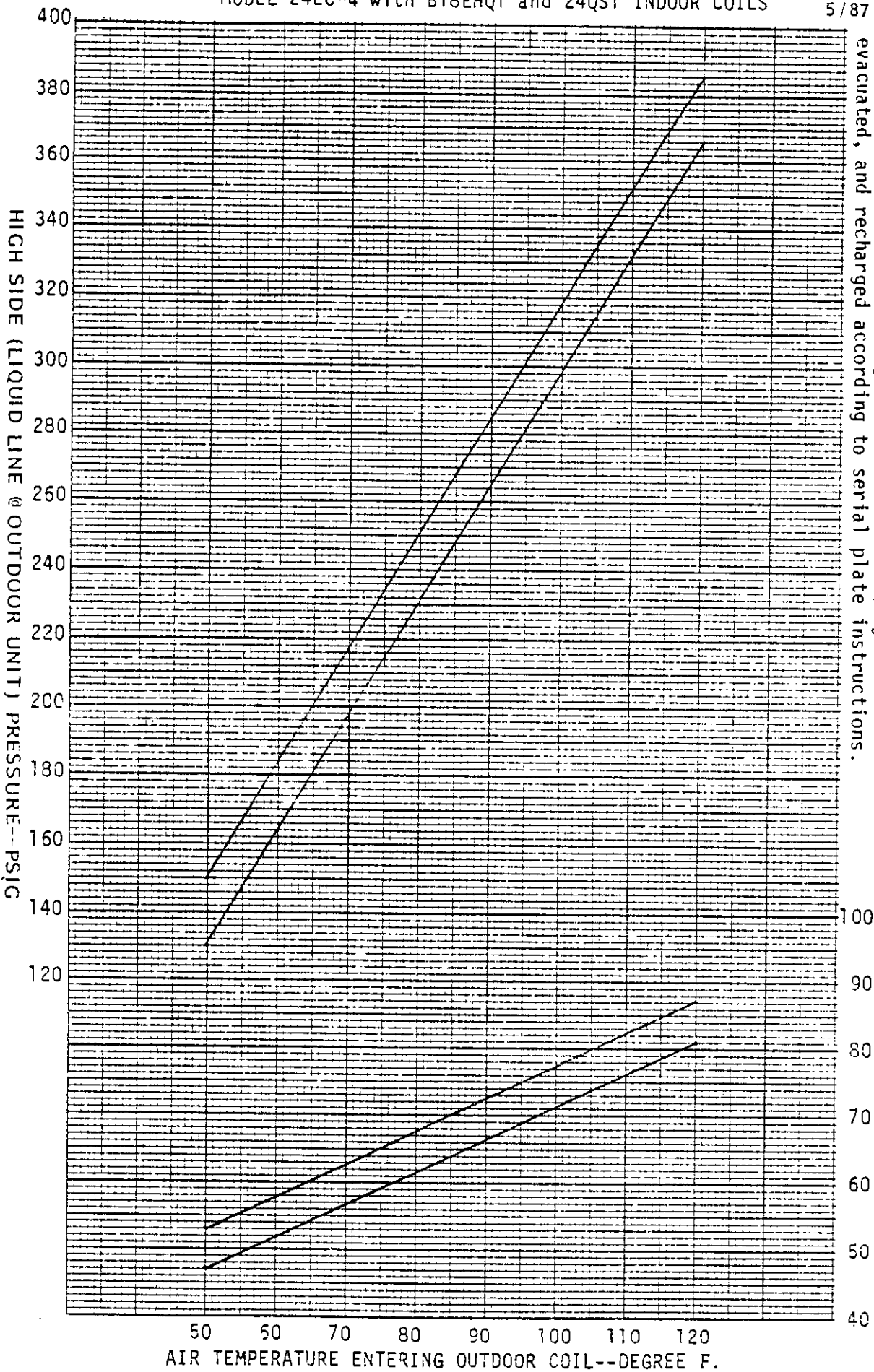

These curves are based upon 80°DB, 67°WB R.A. Temp. and Rated CFM (airflow) across the evaporator coil and should be used for reference purposes only. Special information can be found under section titled "Refrigerant Charge" elsewhere in manual. If there is any doubt as to correct operating charge being in the system, the charge should be removed, system evacuated, and recharged according to serial plate instructions.

LOW SIDE PRESSURE--PSIG
 (SUCTION LINE @ OUTDOOR UNIT)

HIGH SIDE (LIQUID LINE @ OUTDOOR UNIT) PRESSURE--PSIG

AIR TEMPERATURE ENTERING OUTDOOR COIL--DEGREE F.

SPLIT AIR CONDITIONER
 MODEL 24EC*4 with 2ACQ1 INDOOR COIL

5/87

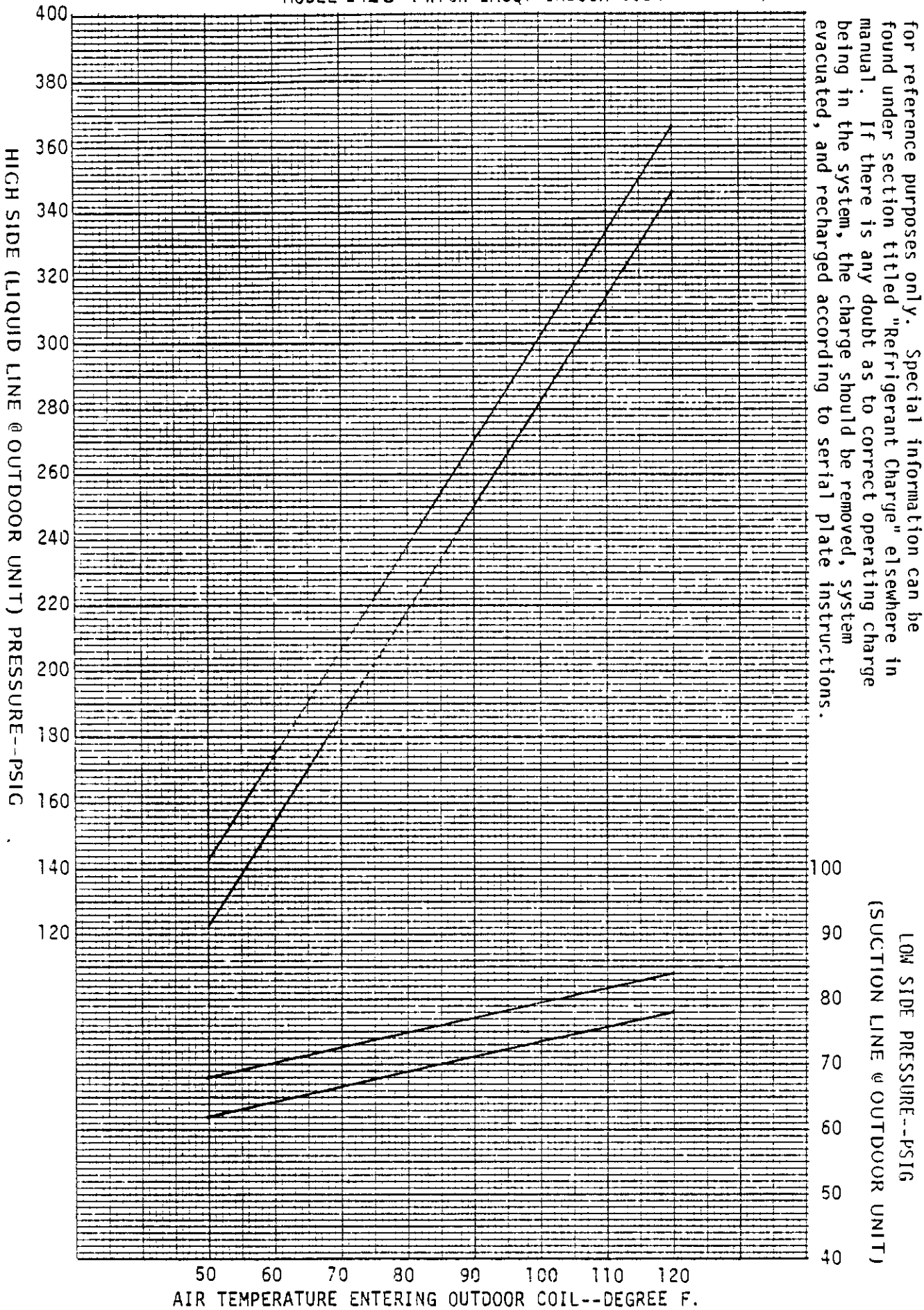

These curves are based upon 80°DB, 67°WB R.A. Temp. and Rated CFM (air-flow) across the evaporator coil and should be used for reference purposes only. Special information can be found under section titled "Refrigerant Charge" elsewhere in manual. If there is any doubt as to correct operating charge being in the system, the charge should be removed, system evacuated, and recharged according to serial plate instructions.

LOW SIDE PRESSURE--PSIG
 (SUCTION LINE @ OUTDOOR UNIT)

SPLIT AIR CONDITIONER
 MODEL 24EC*4 with B24EHQ1 INDOOR COIL

5/87

These curves are based upon 80°DB, 67°WB R.A. Temp. and Rated CFM (air-flow) across the evaporator coil and should be used for reference purposes only. Special information can be found under section titled "Refrigerant Charge" elsewhere in manual. If there is any doubt as to correct operating charge being in the system, the charge should be removed, system evacuated, and recharged according to serial plate instructions.

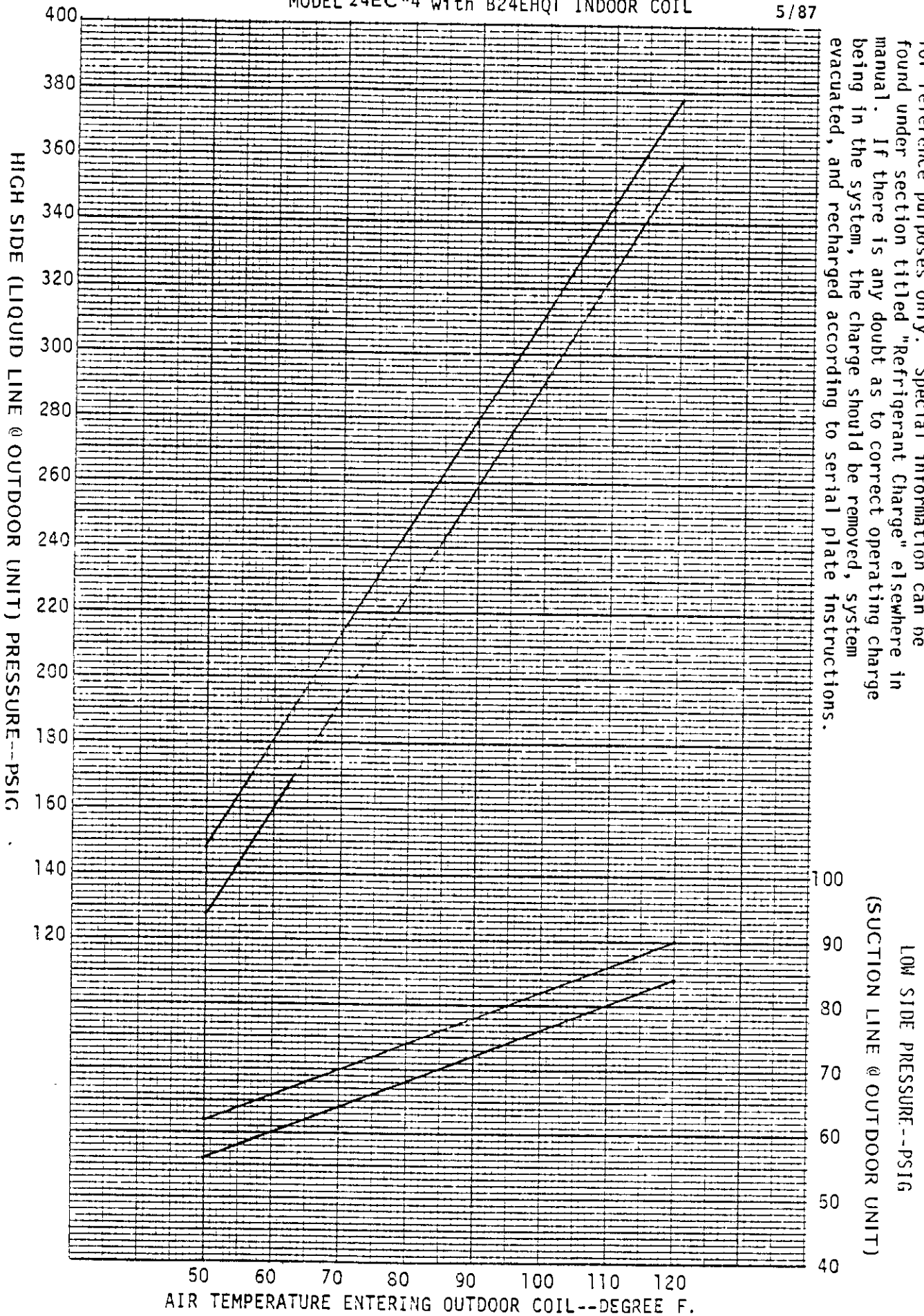

SPLIT AIR CONDITIONER

30EC*.4 With All Matching Indoor Sections

5/87

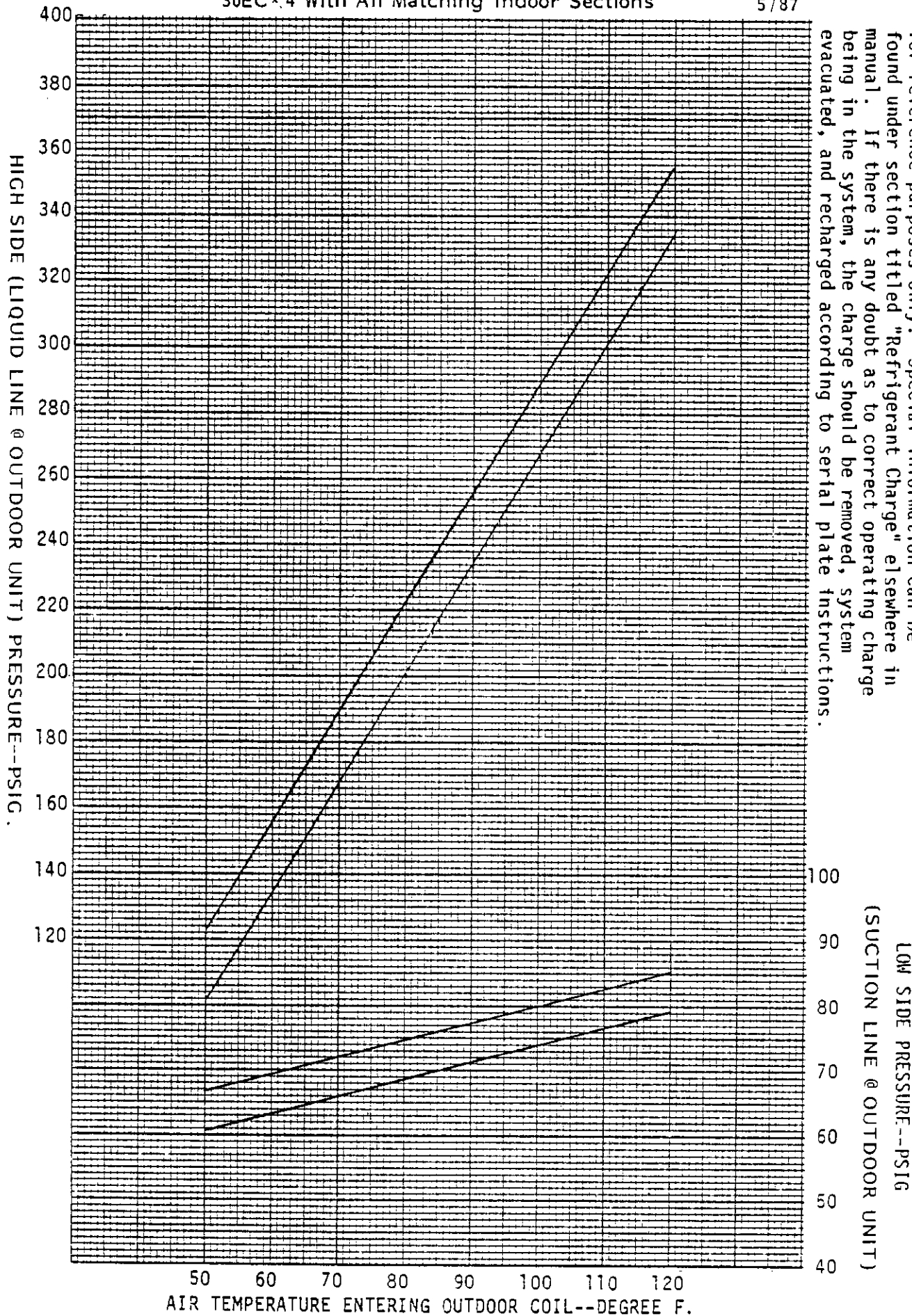

These curves are based upon 80°DB, 67°WB R.A. Temp. and Rated CFM (airflow) across the evaporator coil and should be used for reference purposes only. Special information can be found under section titled "Refrigerant Charge" elsewhere in manual. If there is any doubt as to correct operating charge being in the system, the charge should be removed, system evacuated, and recharged according to serial plate instructions.

LOW SIDE PRESSURE--PSIG
(SUCTION LINE @ OUTDOOR UNIT)

HIGH SIDE (LIQUID LINE @ OUTDOOR UNIT) PRESSURE--PSIG.

AIR TEMPERATURE ENTERING OUTDOOR COIL--DEGREE F.

SPLIT AIR CONDITIONER

31EC *1 With All Matching Indoor Sections

5/87

HIGH SIDE (LIQUID LINE @ OUTDOOR UNIT) PRESSURE--PSIG

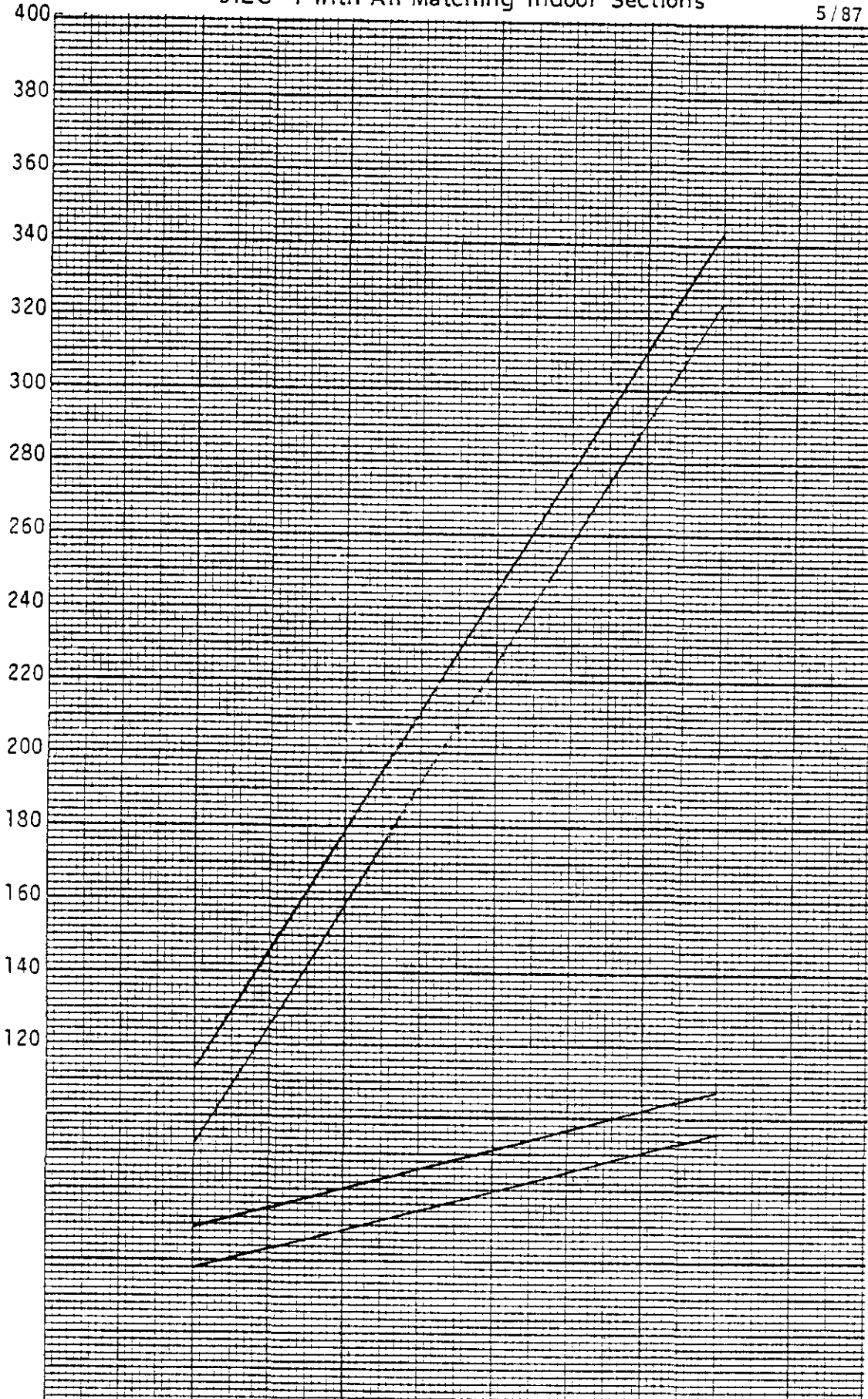

These curves are based upon 80°DB, 67°WB R.A. Temp. and Rated CFM (airflow) across the evaporator coil and should be used for reference purposes only. Special information can be found under section titled "Refrigerant Charge" elsewhere in manual. If there is any doubt as to correct operating charge being in the system, the charge should be removed, system evacuated, and recharged according to serial plate instructions.

LOW SIDE PRESSURE--PSIG
(SUCTION LINE @ OUTDOOR UNIT)

AIR TEMPERATURE ENTERING OUTDOOR COIL--DEGREE F.

SPLIT AIR CONDITIONER

36EC *5 With All Matching Indoor Sections

5/87

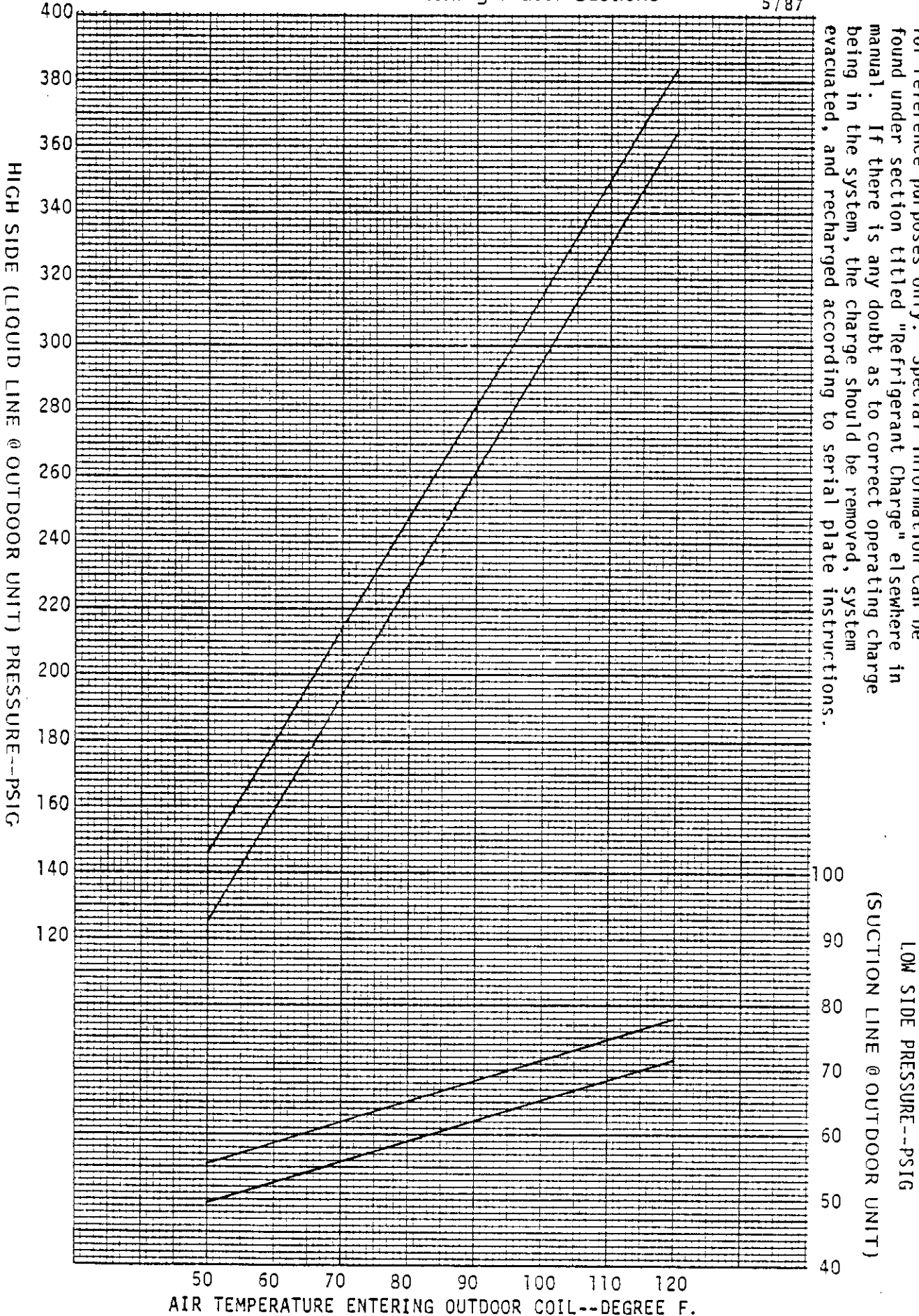

These curves are based upon 80°DB, 67°WB R.A. Temp. and Rated CFM (airflow) across the evaporator coil and should be used for reference purposes only. Special information can be found under section titled "Refrigerant Charge" elsewhere in manual. If there is any doubt as to correct operating charge being in the system, the charge should be removed, system evacuated, and recharged according to serial plate instructions.

SPLIT AIR CONDITIONER

37EC *1 With All Matching Indoor Sections

5/87

These curves are based upon 80°DB, 67°WB R.A. Temp. and Rated CFM (airflow) across the evaporator coil and should be used for reference purposes only. Special information can be found under section titled "Refrigerant Charge" elsewhere in manual. If there is any doubt as to correct operating charge being in the system, the charge should be removed, system evacuated, and recharged according to serial plate instructions.

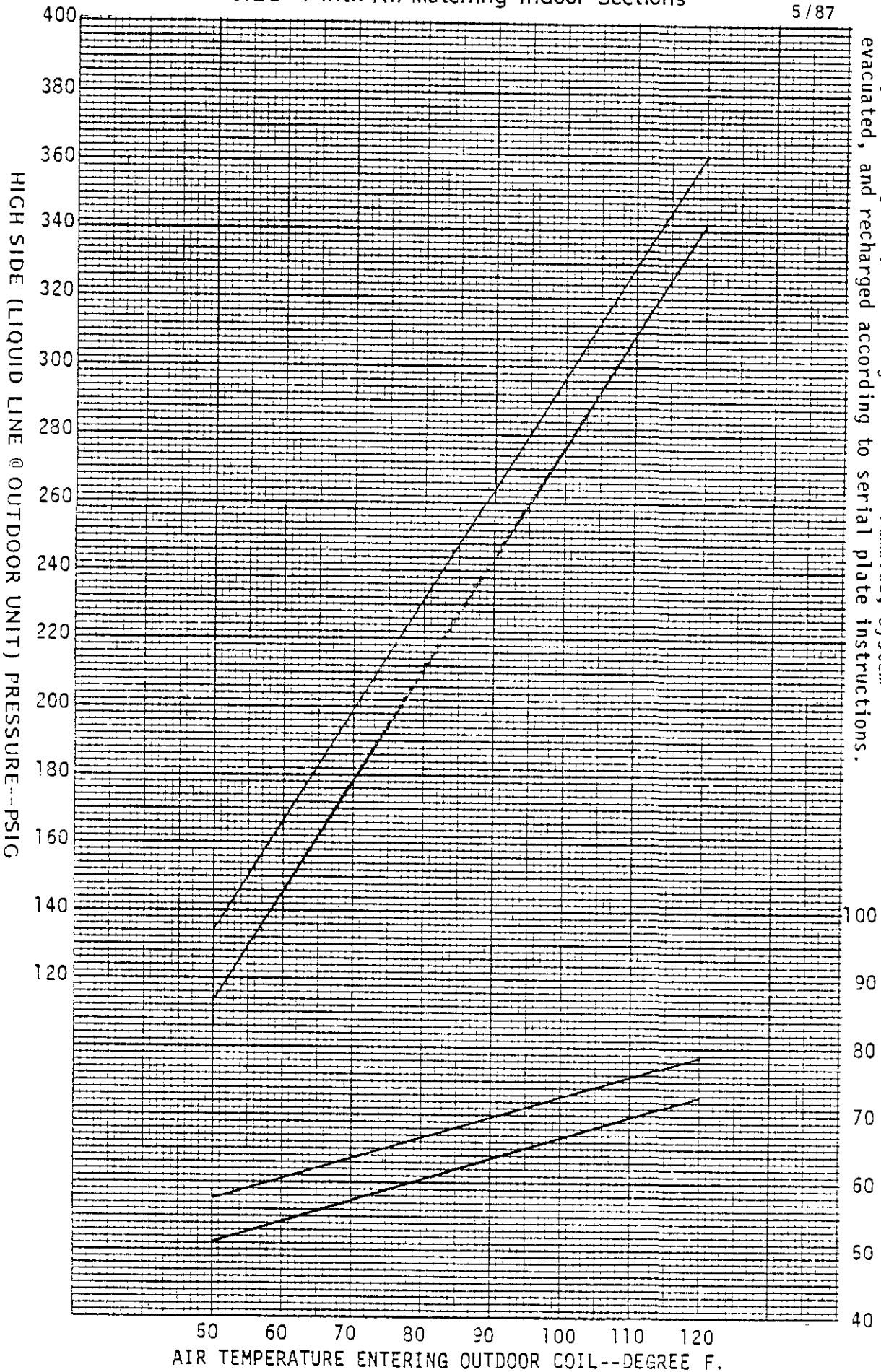

LOW SIDE PRESSURE--PSIG

(SUCTION LINE @ OUTDOOR UNIT)

HIGH SIDE (LIQUID LINE @ OUTDOOR UNIT) PRESSURE--PSIG

AIR TEMPERATURE ENTERING OUTDOOR COIL--DEGREE F.

SPLIT AIR CONDITIONER
 MODEL 42EC*1 with 4ACQ2 and 4HCQ INDOOR COILS

5/87

These curves are based upon 80°DB, 67°WB R.A. Temp. and Rated CFM (airflow) across the evaporator coil and should be used for reference purposes only. Special information can be found under section titled "Refrigerant Charge" elsewhere in manual. If there is any doubt as to correct operating charge being in the system, the charge should be removed, system evacuated, and recharged according to serial plate instructions.

HIGH SIDE (LIQUID LINE @ OUTDOOR UNIT) PRESSURE--PSIG

LOW SIDE PRESSURE--PSIG
 (SUCTION LINE @ OUTDOOR UNIT)

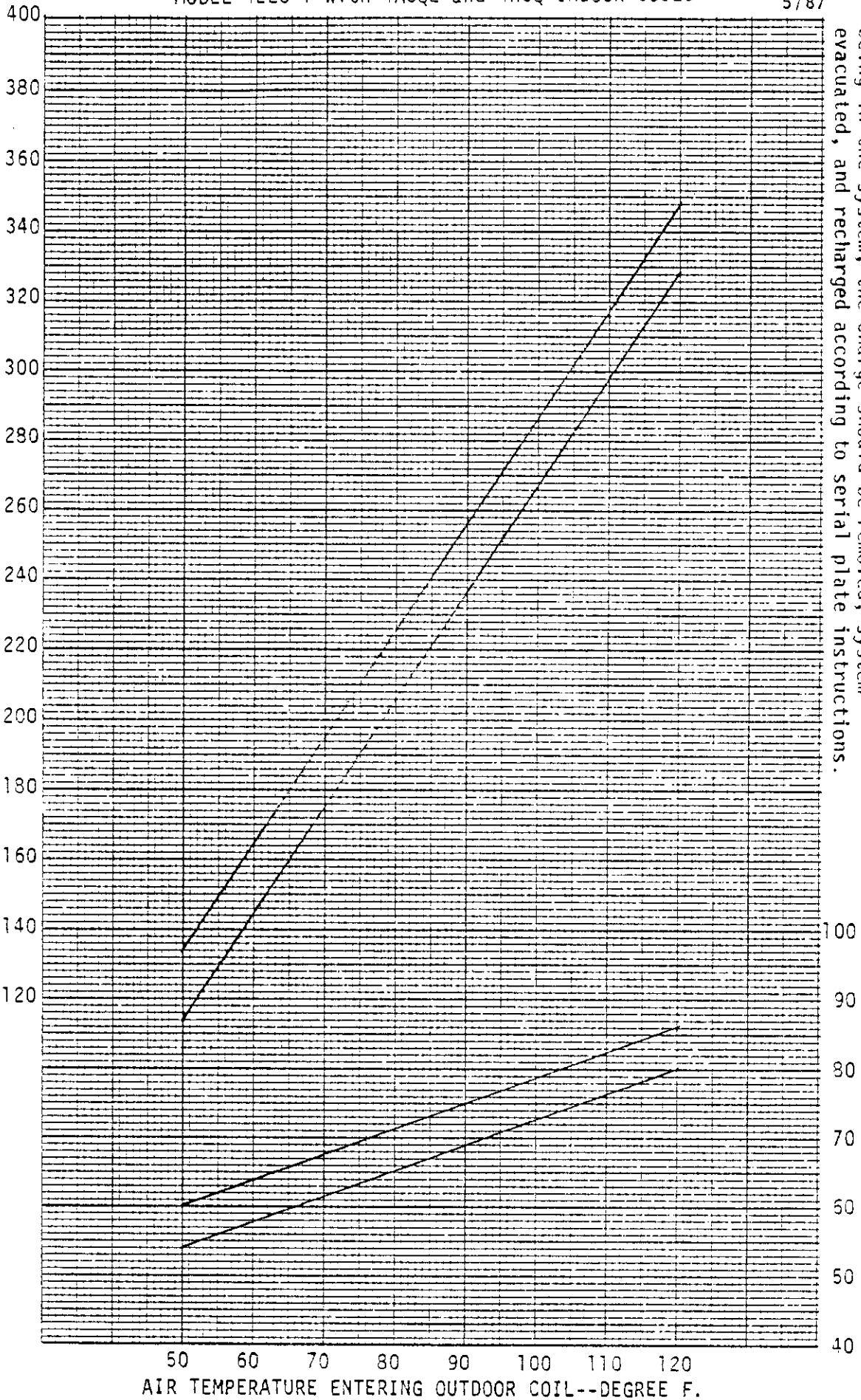

AIR TEMPERATURE ENTERING OUTDOOR COIL--DEGREE F.

SPLIT AIR CONDITIONER
 MODEL 42EC*1 with 8C48A and 5ACQ1 INDOOR COILS

5/87

These curves are based upon 80°DB, 67°WB R.A. Temp. and Rated CFM (air-flow) across the evaporator coil and should be used for reference purposes only. Special information can be found under section titled "Refrigerant Charge" elsewhere in manual. If there is any doubt as to correct operating charge being in the system, the charge should be removed, system evacuated, and recharged according to serial plate instructions.

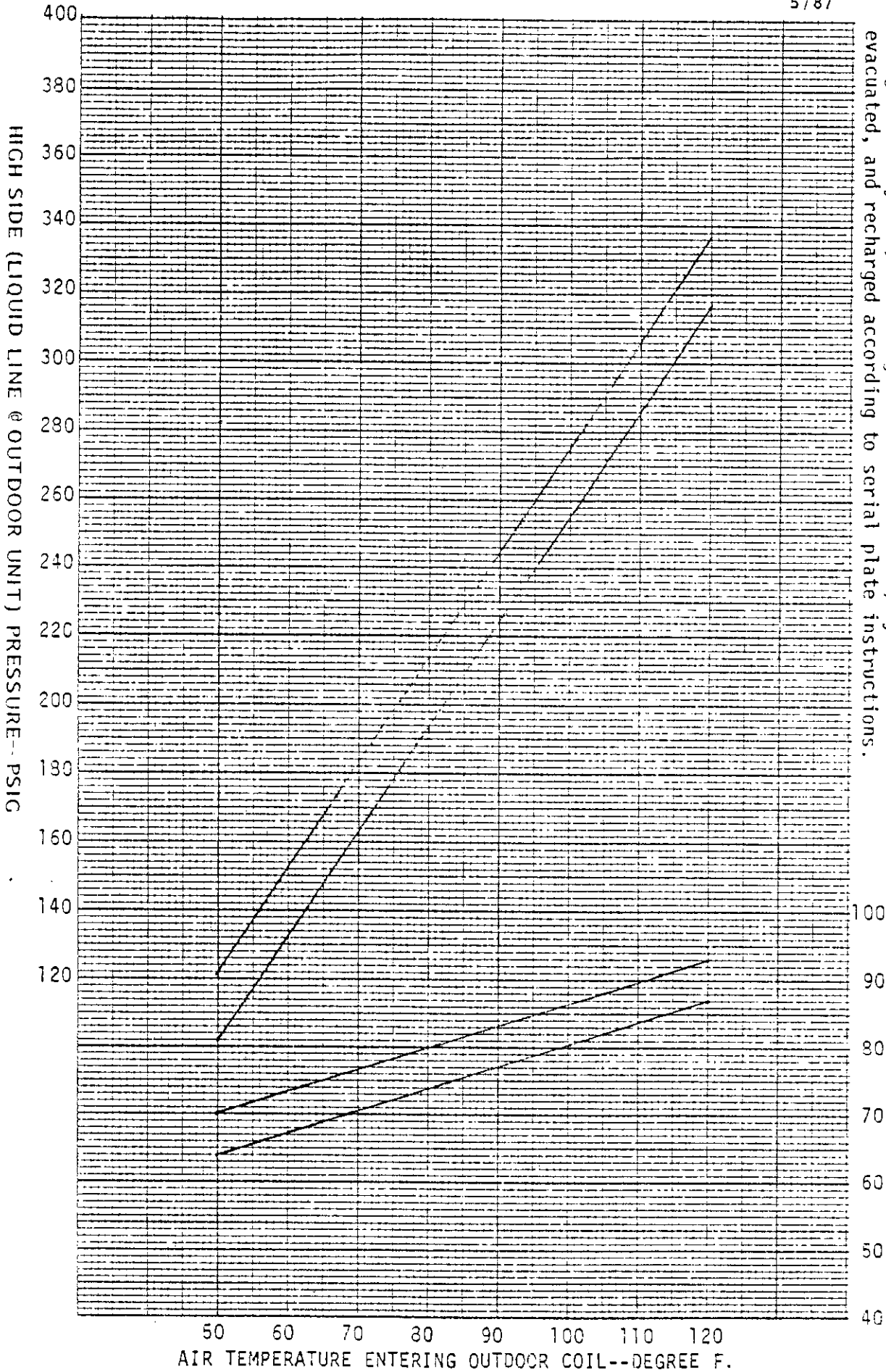

LOW SIDE PRESSURE--PSIG
 (SUCTION LINE @ OUTDOOR UNIT)

HIGH SIDE (LIQUID LINE @ OUTDOOR UNIT) PRESSURE--PSIG

AIR TEMPERATURE ENTERING OUTDOOR COIL--DEGREE F.

SPLIT AIR CONDITIONER
 MODEL 48EC*2 with 4ACQ2 and 4HCQ INDOOR COILS

5/87

These curves are based upon 80°DB, 67°WB R.A. Temp. and Rated CFM (airflow) across the evaporator coil and should be used for reference purposes only. Special information can be found under section titled "Refrigerant Charge" elsewhere in manual. If there is any doubt as to correct operating charge being in the system, the charge should be removed, system evacuated, and recharged according to serial plate instructions.

HIGH SIDE (LIQUID LINE @ OUTDOOR UNIT) PRESSURE--PSIG

LOW SIDE PRESSURE--PSIG
 (SUCTION LINE @ OUTDOOR UNIT)

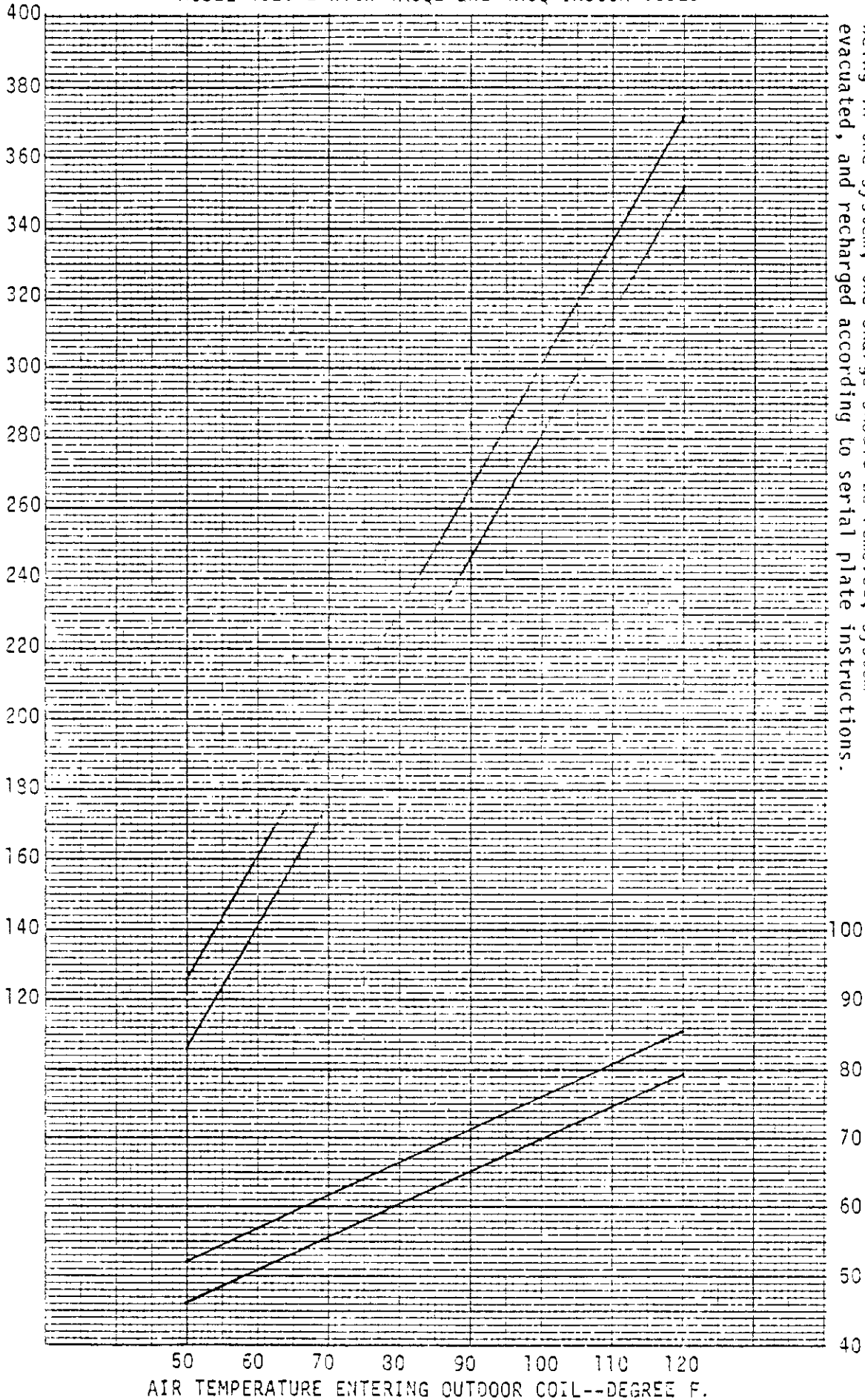

SPLIT AIR CONDITIONER
 MODEL 48EC*2 with BC48A and 5ACQ1 INDOOR COILS

5/87

These curves are based upon 80°DB, 67°WB R.A. Temp. and Rated CFM (airflow) across the evaporator coil and should be used for reference purposes only. Special information can be found under section titled "Refrigerant Charge" elsewhere in manual. If there is any doubt as to correct operating charge being in the system, the charge should be removed, system evacuated, and recharged according to serial plate instructions.

HIGH SIDE (LIQUID LINE @ OUTDOOR UNIT) PRESSURE--PSIG

LOW SIDE PRESSURE--PSIG
 (SUCTION LINE @ OUTDOOR UNIT)

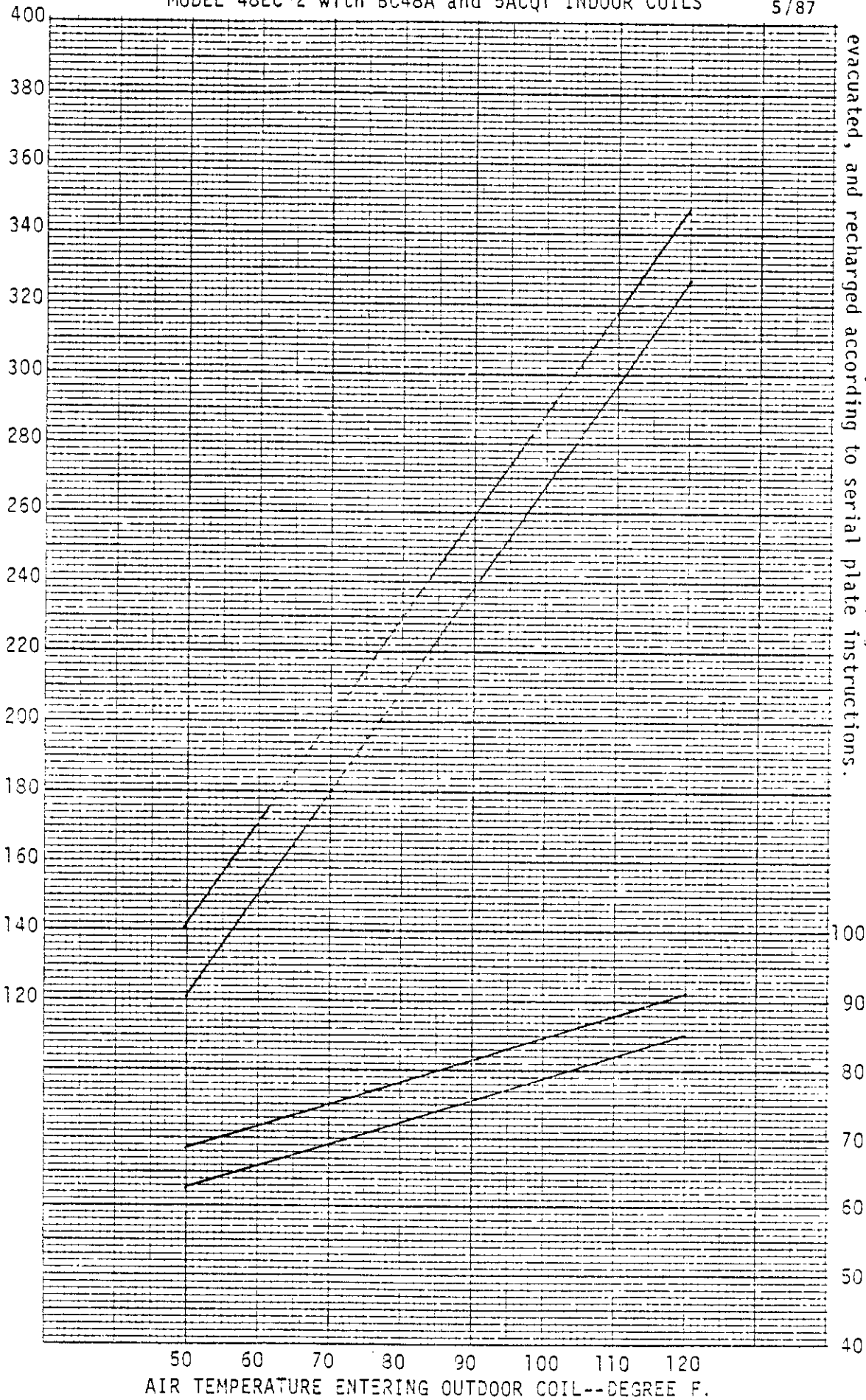

AIR TEMPERATURE ENTERING OUTDOOR COIL--DEGREE F.

SPLIT AIR CONDITIONER
 Model 60EC*1 with BC60A Indoor Coil

5/87

These curves are based upon 80°DB, 67°WB R.A. Temp. and Rated CFM (air-flow) across the evaporator coil and should be used for reference purposes only. Special information can be found under section titled "Refrigerant Charge" elsewhere in manual. If there is any doubt as to correct operating charge being in the system, the charge should be removed, system evacuated, and recharged according to serial plate instructions.

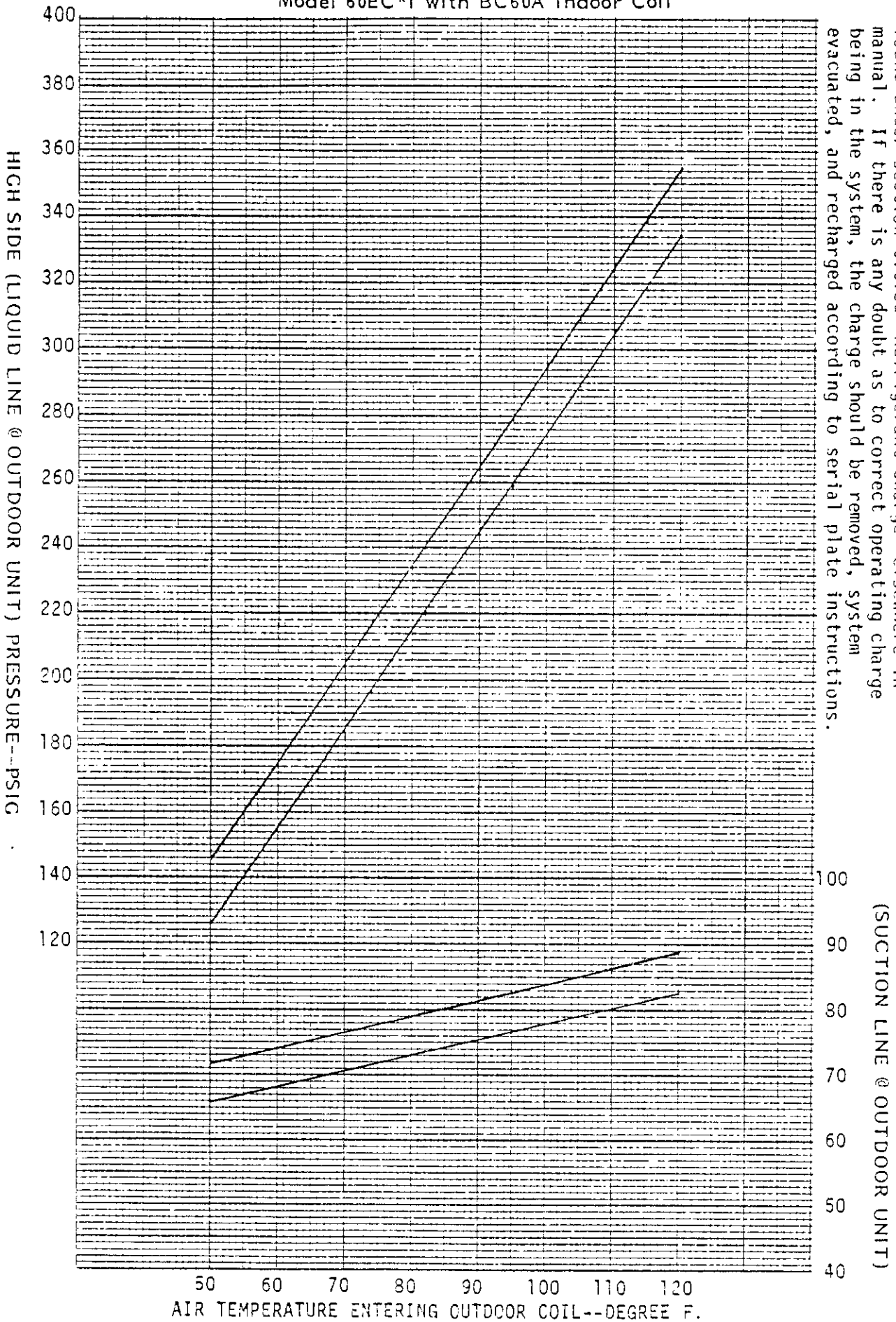

LOW SIDE PRESSURE--PSIG

(SUCTION LINE @ OUTDOOR UNIT)

SPLIT AIR CONDITIONER
 MODEL 60EC*1 with BC48A, 5ACQ1 and 5HCQ INDOOR COILS

5/87

These curves are based upon 80°DB, 67°WB R.A. Temp. and Rated CFM (airflow) across the evaporator coil and should be used for reference purposes only. Special information can be found under section titled "Refrigerant Charge" elsewhere in manual. If there is any doubt as to correct operating charge being in the system, the charge should be removed, system evacuated, and recharged according to serial plate instructions.

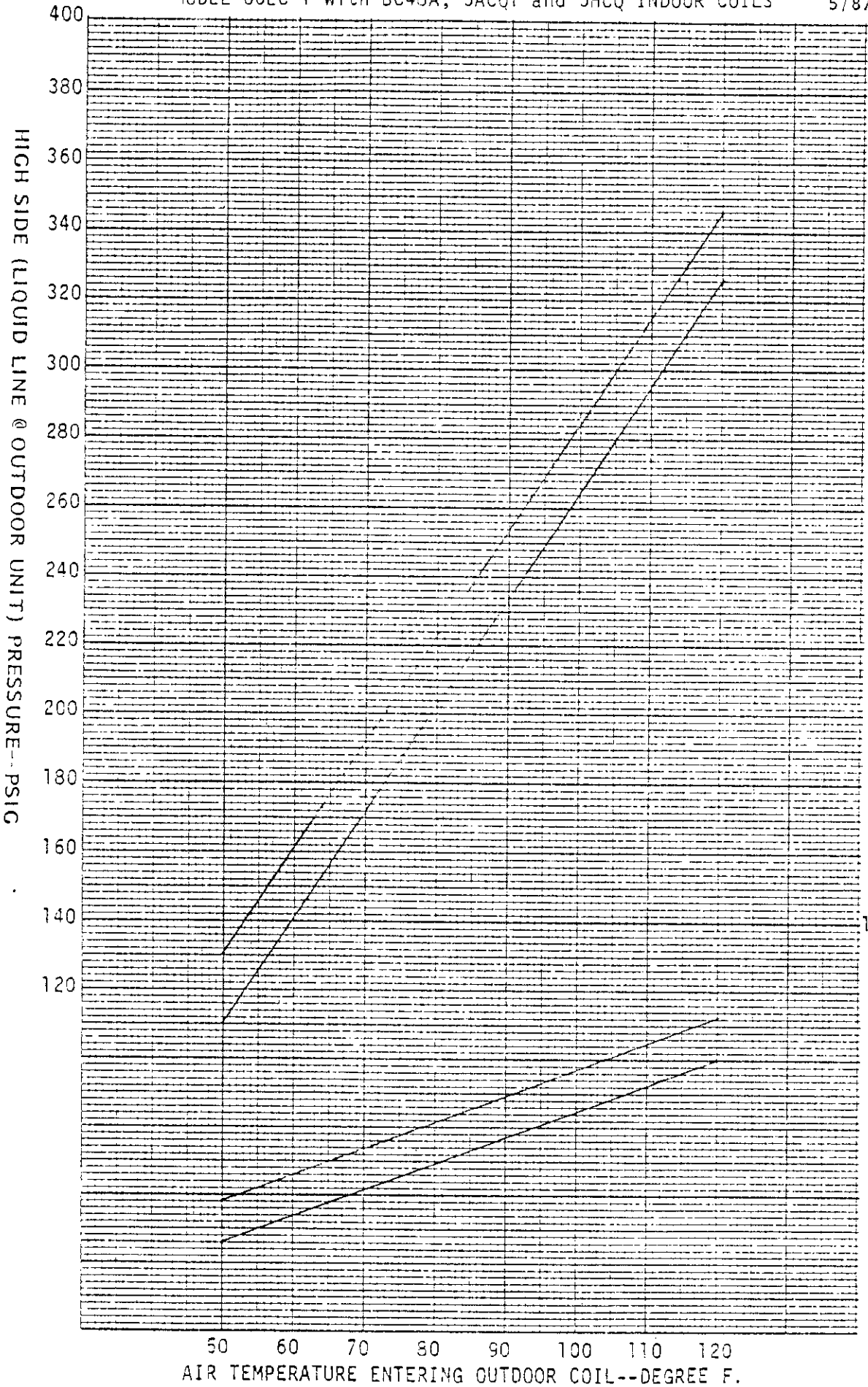

LOW SIDE PRESSURE--PSIG
 (SUCTION LINE @ OUTDOOR UNIT)

HIGH SIDE (LIQUID LINE @ OUTDOOR UNIT) PRESSURE--PSIG

AIR TEMPERATURE ENTERING OUTDOOR COIL--DEGREE F.

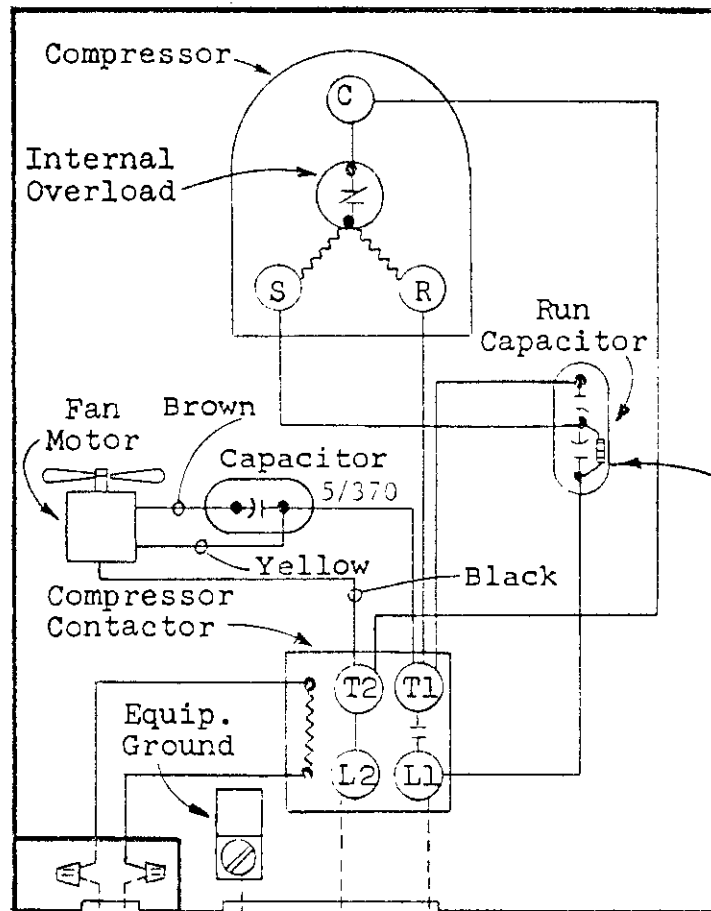

CAPACITOR	
Model	Size
13ECQ2	15/10-370
24ECQ4	20/15-370

Use Minimum Transformer Rating of 40VA

Use Copper Conductors Only

C Y
24V
Factory Wiring

Fused Disconnect Switch

Field Wiring

230/208-60-1

4021-1102

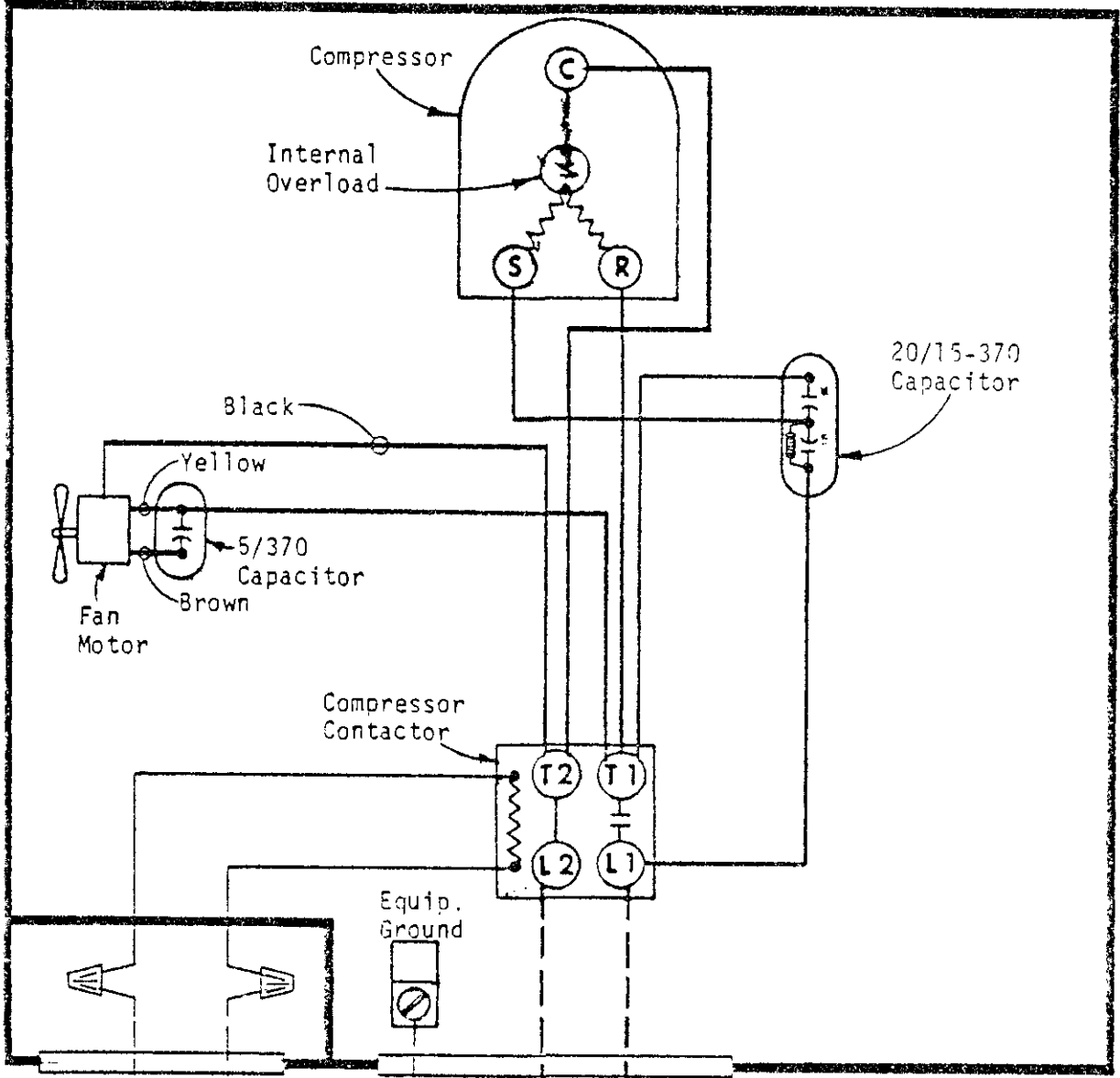

Use Minimum Transformer Rating of 40VA

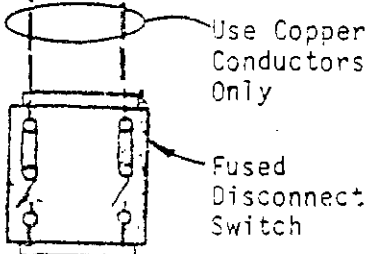
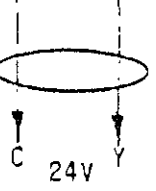

FACTORY WIRING	FIELD WIRING
Low Voltage	-----
High Voltage	- - - - -

230/208-60-1

4062-110 A

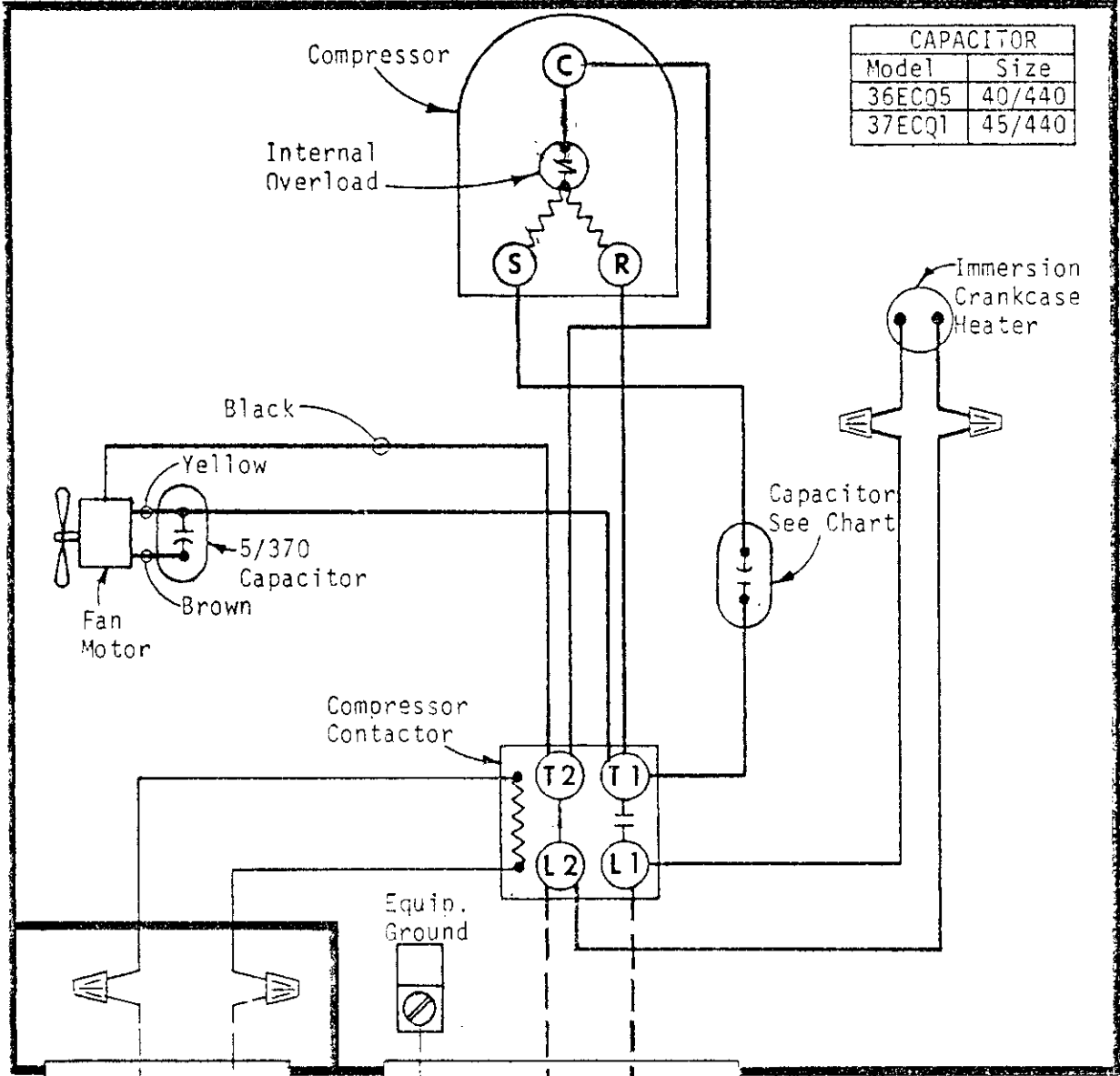

CAPACITOR	
Model	Size
36ECQ5	40/440
37ECQ1	45/440

Use Minimum Transformer Rating of 40VA

C 24V Y

Use Copper Conductors Only

Fused Disconnect Switch

	FACTORY WIRING	FIELD WIRING
Low Voltage	————	- - - - -
High Voltage	————	- - - - -

230/208-60-1

4962-111 B

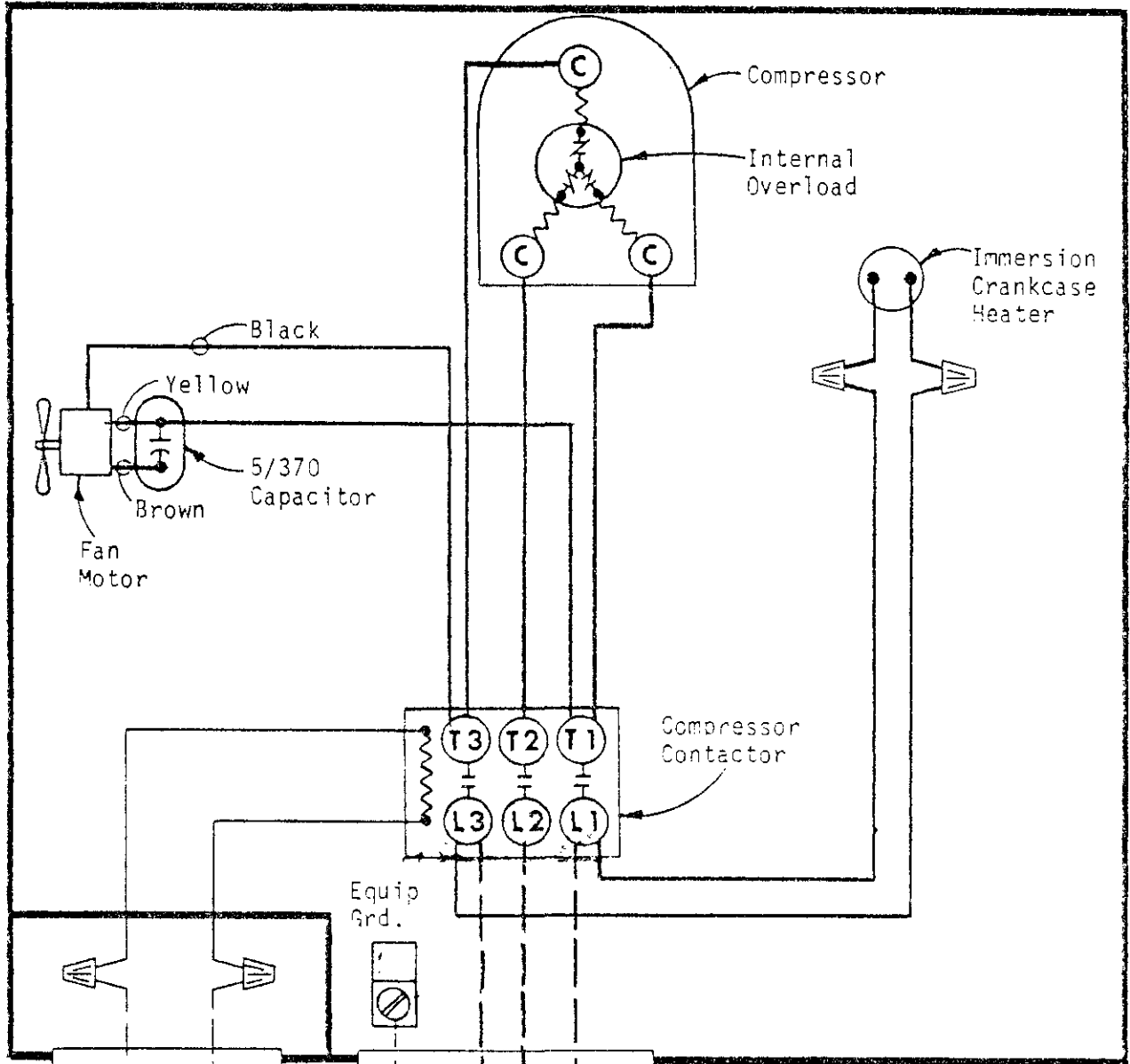

	FACTORY WIRING	FIELD WIRING
Low Voltage	—————	-----
High Voltage	—————	-----

230/208-60-3
240/200-50-3

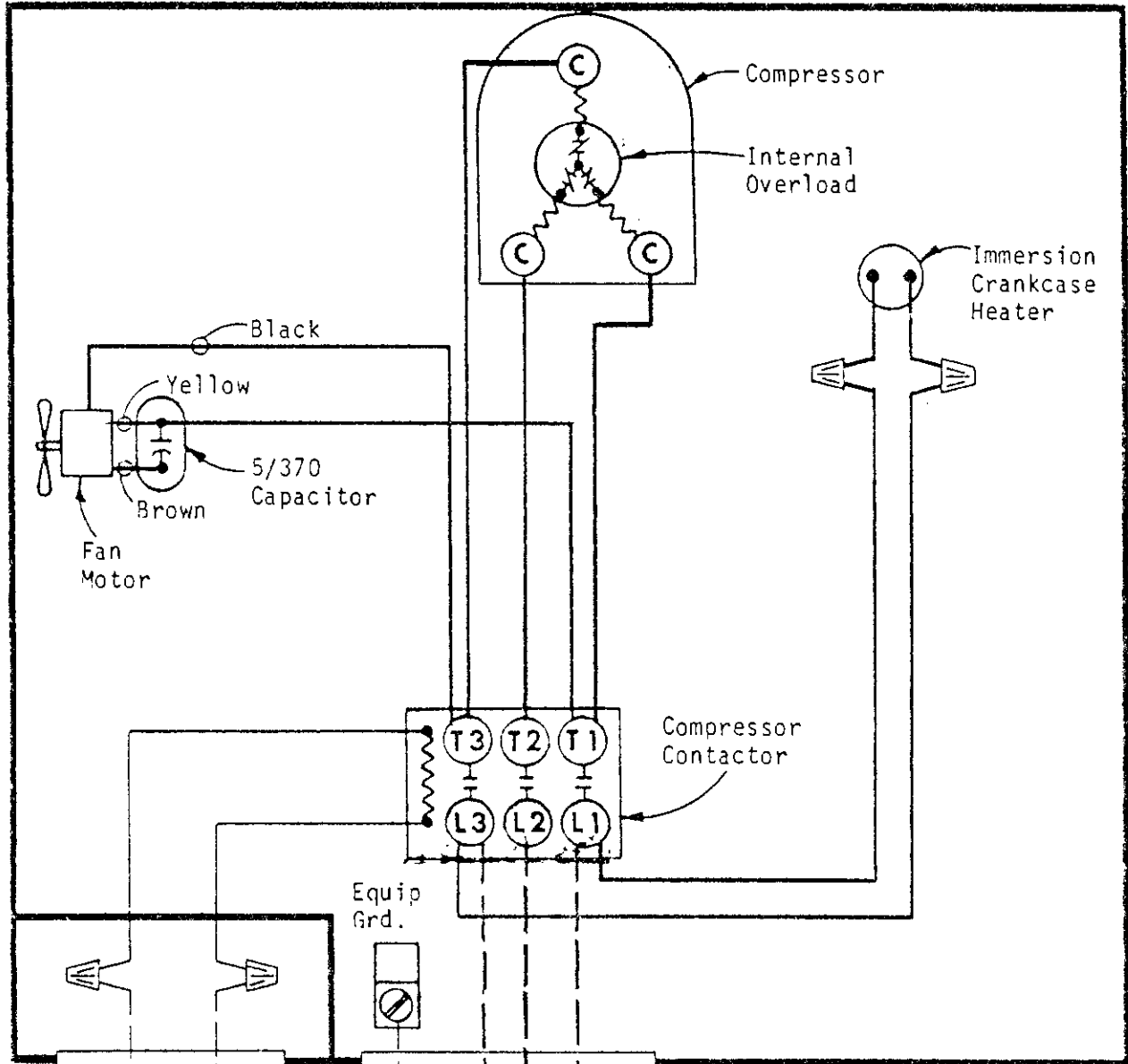

Use Minimum Transformer Rating of 40VA

24V

Fused Disconnect Switch

460-60-3

	FACTORY WIRING	FIELD WIRING
Low Voltage	—————	- - - - -
High Voltage	—————	- - - - -

4062-310B

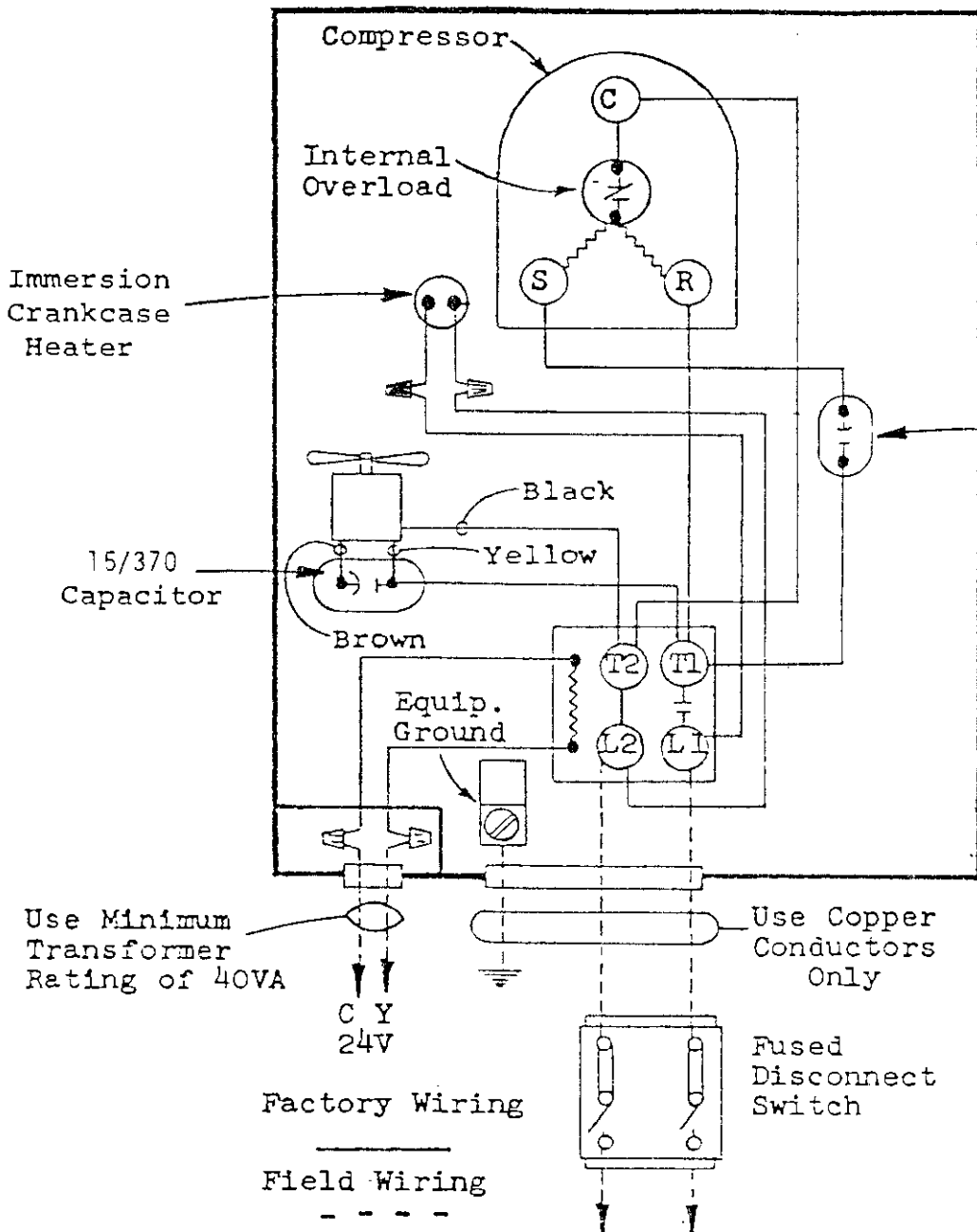

CAPACITOR	
Model	Size
42ECQ1	40/440
48ECQ2	70/370
60ECQ1	45/440

230/208-60-1

4025-110 D

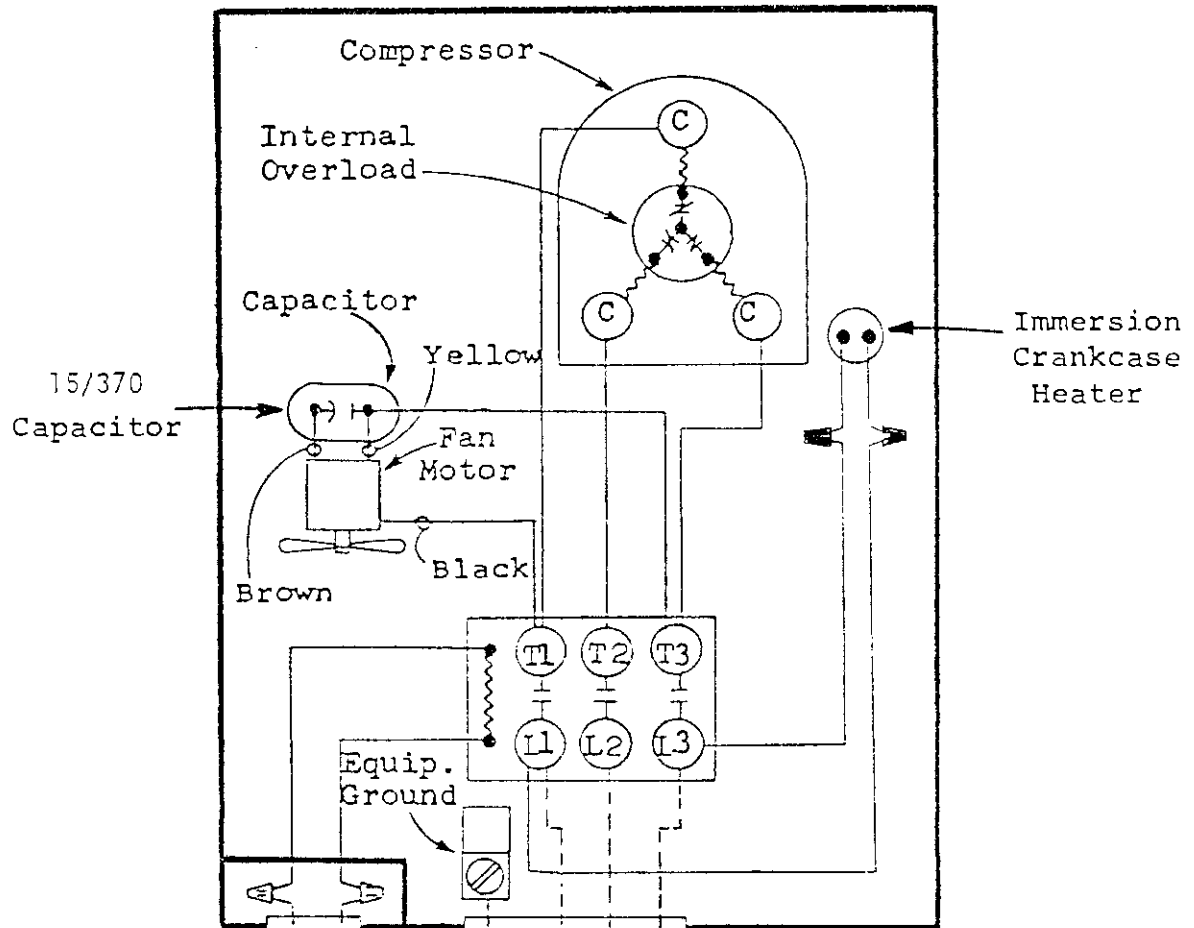

Use Minimum
Transformer
Rating of 40VA

Use Copper
Conductors
Only

C Y
24V

Factory Wiring

Field Wiring

Fused
Disconnect
Switch

230/208-60-3

4025-210 C

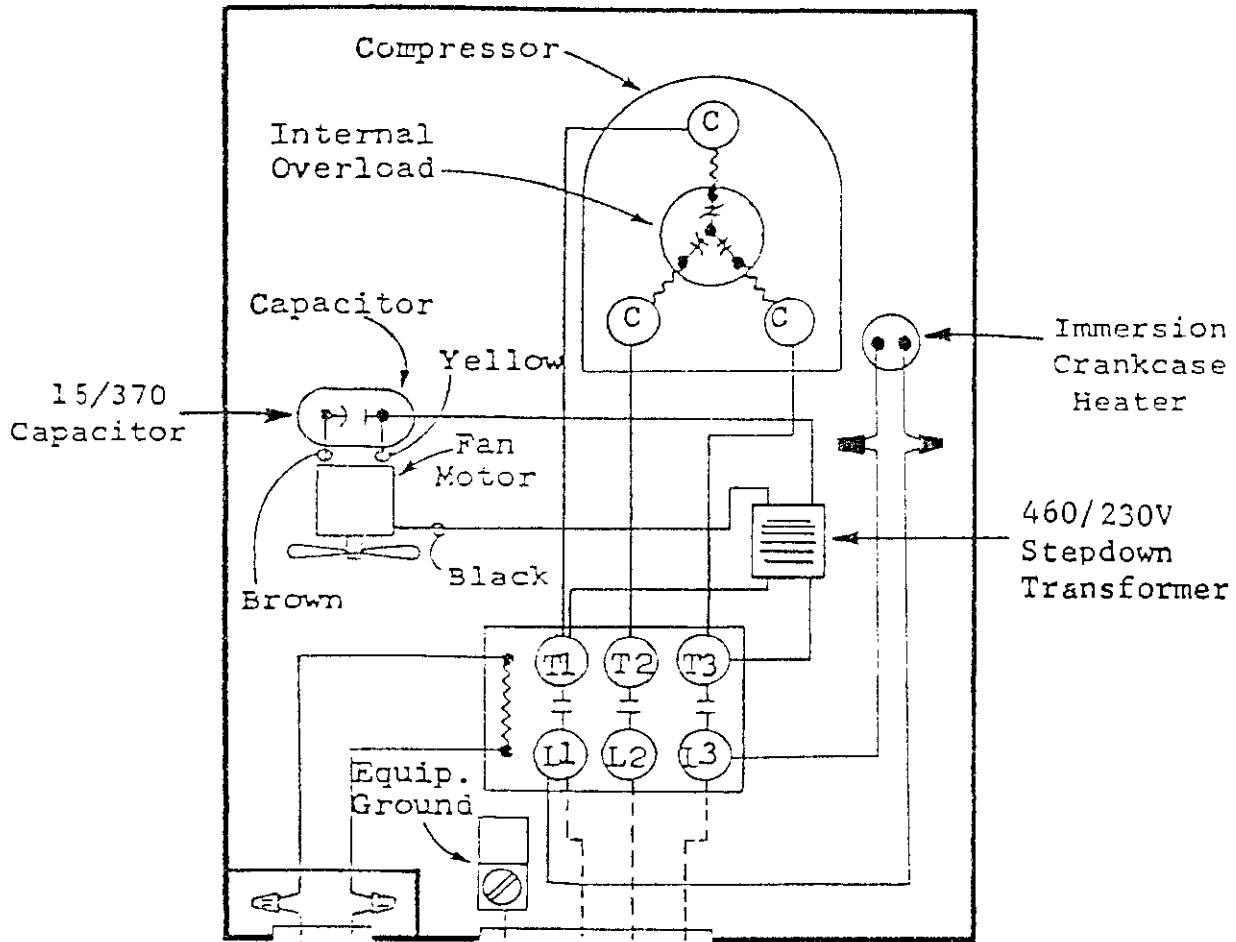

Use Minimum
Transformer
Rating of 40VA

Use Copper
Conductors
Only

C Y
24V

Factory Wiring

Field Wiring

Fused
Disconnect
Switch

460-60-3

4025-510 C