

# INSTALLATION INSTRUCTIONS

## MODELS

18HPQ5, 24HPQ5

**SPLIT HEAT PUMP UNIT  
OUTDOOR SECTIONS**

**FOR USE WITH  
MATCHING BARD INDOOR BLOWER  
COIL UNITS AND MATCHING  
ADD ON COIL ONLY UNITS**

## IMPORTANT

The equipment covered in this manual is to be installed by trained, experienced service and installation technicians. Any heat pump is more critical of proper operating charge and an adequate duct system than a straight air conditioning unit. All ductwork, supply and return, must be properly sized for the design air flow requirement of the equipment. ACCA is an excellent guide to proper sizing. All ductwork or portions thereof not in the conditioned space should be properly insulated in order to both conserve energy and prevent condensation or moisture damage.

## SHIPPING DAMAGE

Upon receipt of equipment, the carton should be checked for external signs of shipping damage. If damage is found, the receiving party must contact the least carrier immediately, preferably in writing, requesting inspection by the carrier's agent.

## GENERAL

These instructions explain the recommended method to install the air-cooled split type heat pump, the interconnected refrigerant tubing, and the electrical wiring required for both unit power and control circuit.

These units are to be used in conjunction with the matching indoor coil sections as shown on the specification sheet. Only those combinations as shown are authorized or recommended.

These instructions and any instructions packaged with any separate equipment required to make up the entire heat pump system should be carefully read before beginning the installation. Note particularly any tags and/or local codes in any way. Authorities having jurisdiction should be consulted before the installation is made.

## PRESSURE SERVICE PORTS

High and low pressure service ports are installed on all units so that the system operating pressures can be observed. Pressure curves can be found later in the manual covering all models on both cooling and heating cycles. It is imperative to match the correct pressure curve to the unit by model number.

## SETTING THE UNIT

**General** - The unit must be located outside, or in a well ventilated area. It must not be in the space being heated or cooled. A sound absorbing material should be considered if the unit is to be installed in such a position or location that might cause transmission of sound or vibration to the living area or adjacent buildings.

## SLAB MOUNTING

In areas where winter temperatures DO NOT go below 32°F for periods over twelve hours, the unit may be slab mounted at grade level. When installing unit at grade level, install on a concrete slab at least four inches above finished grade level. Slab should have a slope tolerance away from the building structure of at least 1/4 inch per foot, while being level from side to side. This will prevent ice buildup under the unit during defrost cycles. Place slab in a location where run-off water from higher ground will not collect around unit. See Figure 1.

A minimum of 18 inches should be provided between the coil inlet and any building surfaces. Provide at least four feet between coil outlet and any building wall, fences or other vertical structures. Provide a minimum of three feet clearance on the service access side of the unit. Refer to Figure 2.

## ROOF MOUNTING

When a unit is installed in areas where low ambient temperatures or strong winter winds exist, it should be placed so prevailing winter winds are not in direct line with the heat pump coil. If this is not possible, a wind barrier should be constructed. Place barrier 24 inches from the coil inlet side of the unit and in the direction of prevailing winds. Size barrier at least the same height and width as the unit. See Figure 3.

## WINTER INSTALLATION BELOW 32°F

In areas where winter conditions go below 32°F for extended periods, the unit must be elevated above the mounting surface to prevent snowfall or defrost ice accumulation from interfering with the operation of the unit. A minimum of twelve inch elevation is recommended, while greater elevation may be required for areas of high snow accumulation. Poured concrete, steel framework, brick, cement block, etc. can be utilized to construct a suitable raised mounting platform. See Figure 4.

## WIRING - MAIN POWER

Refer to the unit rating plate for wire sizing information and maximum fuse or "HACR Type" circuit breaker size. Each outdoor unit is marked with a "Minimum Circuit Ampacity." This means that the field wiring used must be sized to carry that amount of current. Depending on the installed Kw of electric heat, there may be two field power circuits required. If this is the case, the unit serial plate will so indicate. Some models are suitable only for connection with copper wire, while others can be wired with either copper or aluminum wire. Each unit and/or wiring diagram will be marked "Use Copper Conductors Only" or "Use Copper or Aluminum Conductors." These instructions MUST BE adhered to. Refer to the National Electrical Code for complete current carrying capacity data on the various insulation grades of wiring material.

The unit rating plate lists a "Maximum Time Delay Fuse" or "HACR Type" circuit breaker that is to be used with the equipment. The correct size must be used for proper circuit protection and also to assure that there will be no nuisance tripping due to the momentary high starting current of the compressor motor.

## WIRING - CONTROL CIRCUIT

Since the same outdoor unit can in most cases be matched with more than one indoor unit, the appropriate control circuit wiring diagrams are included with the indoor coil section installation instructions. These control circuit wiring diagrams cover all the available wiring options required in the various geographic areas of the country.

## REFRIGERANT CHARGE

The correct system R-22 is shown on the unit rating plate. Optimum unit performance will occur with a refrigerant charge resulting in a suction line temperature (6" from compressor) as shown in the following table:

Models	Rated Airflow	95°F O.D. Temp	82°F O.D. Temp.
18HPQ5/B18EHQ1 18HPQ5/H18QS1	625 625	68 - 70 68 - 70	73 - 75 73 - 75
24HPQ5/B24EHQ1 24HPQ5/H24QS1	800 765	64 - 66 64 - 66	69 - 71 69 - 71
18HPQ5/B24EHQ1 18HPQ5/H24QS1	635 635	64 - 66 64 - 66	69 - 71 69 - 71
24HPQ5/B18EHQ1 24HPQ5/H18QS1	730 730	67 - 69 67 - 69	73 - 75 73 - 75

NOTE: The suction line temperatures are based upon 80°F dry bulb / 67°F wet bulb (50% R.H.) temperature and rated air flow across the evaporator during cooling cycle.

NOTE: For 18HPQ5/B24EHQ1 airflow run on low speed 0-5KW units only. 10+5KW units must be run on high speed only.

## SEQUENCE OF OPERATION

**Cooling** - Circuit R-Y makes at thermostat pulling in compressor contactor starting the compressor and outdoor motor. The G (indoor motor) circuit is automatically completed on any call for cooling operation, or can be energized by manual fan switch on subbase for constant air circulation.

**Heating** - A 24V solenoid coil on reversing valve controls heating cycle operation. Two thermostat options, one allowing "Auto" changeover from cycle to cycle and the other constantly energizing solenoid coil during heating season and thus eliminating pressure equalization noise except during defrost, are to be used. On "Auto" option, a circuit is completed from R-W1 and R-Y on each heating "on" cycle, energizing reversing valve solenoid and pulling in compressor contactor starting compressor and outdoor motor. R-G also make starting indoor blower motor. Heat pump heating cycle is now in operation. The second option has no "Auto" changeover position, but instead energizes the reversing valve solenoid constantly whenever the system switch on subbase is placed in "heat" position, the "B" terminal being constantly energized from R. A thermostat demand for heat completes R-Y circuit, pulling in compressor contactor starting compressor and outdoor motor. R-G also make starting indoor blower motor.

WALL THERMOSTAT AND SUBBASE COMBINATIONS			
Group	Thermostat	Subbase	Predominant Feature
A	8403-017 (T874R1129)	8404-009 (Q674L1181)	Heat or Cool ① No Auto
B	8403-018 (T874N1024)	8404-010 (Q674F1261)	Automatic Heat-Cool Changeover Position ②

① No automatic changeover position--must manually place in heat or cool. Reversing valve remains energized at all times system switch is in heat position (except during defrost cycle). No pressure equalization noise when thermostat is satisfied on either heating or cooling.

② Allows thermostat to control both heating and cooling operation when set in "AUTO" position. Reversing valve de-energizes at end of each "ON" heating cycle.

**IMPORTANT NOTE:** Both thermostat and subbase combinations shown above incorporate the following features: Man-Auto fan switch, Off-Heat-Cool-Em. Heat Switch, and two (2) indicator lamps--one for emergency heat and one for compressor malfunction.

### THERMOSTAT INDICATOR LAMPS

The red lamp marked "EM.HT." comes on and stays on whenever the system switch is placed in the emergency heat position. The green lamp marked "check" will come on if there is any problem that prevents the compressor from running when it is supposed to be.

### EMERGENCY HEAT POSITION

The operator of the equipment must manually place the system switch in this position. This is done when there is a known problem with the outdoor section, or when the green "check" lamp comes on indicating a problem.

### COMPRESSOR MALFUNCTION RELAY (1-Ph models only)

Actuation of the green "check" lamp is accomplished by a voltage type relay which is factory installed. Any condition such as loss of charge, defective capacitor, defective contactor, etc., that will prevent compressor from operating will cause green lamp to activate. This is a signal to the operator of the equipment to place system in emergency heat position.

## DEFROST CYCLE

The defrost cycle is controlled by time and temperature. The 24 volt timer motor runs all the time the compressor is in operation. When the outdoor temperature is in the lower 40°F temperature range or colder, the outdoor coil temperature is 32°F or below. This temperature is sensed by the defrost thermostat mounted near the bottom of the outdoor coil on a return bend. The defrost thermostat closes at approximately 32°F. Every 60 (or 30) minutes that the compressor is running, contacts 3-5 close for 7 minutes, with contacts 3-4 closed for the first 40 seconds of that 7 minutes. If the defrost thermostat is closed, the defrost relay energizes and places the system in defrost mode. An interlocking circuit is created with timer contacts 3-5 and defrost relay contacts 7-9 in series.

During the defrost mode, the refrigerant cycle switches back to the cooling cycle, the outdoor motor stops, electric heaters are energized, and hot gas passing through the outdoor coil melts any accumulated frost. When the temperature rises to approximately 57°F, the defrost thermostat opens, de-energizing the defrost relay and returning the system to heating operation.

If some abnormal or temporary condition such as a high wind causes the heat pump to have a prolonged defrost cycle, contacts 3-5 of the defrost timer will open after 7 minutes and restore the system to heating operations automatically.

There are two time settings on the defrost timer--30 minutes and 60 minutes. Most models are shipped wired on the 60 minute setting for greatest operating economy. If special circumstances require a change to the shorter time, remove wire connected to terminal 5/60 and reconnect to terminal 5/30. See next page.

There is a manual advance knob located on the timer. This can be used to advance timer to contact closure point if it is desired to check out defrost cycle operation without waiting for time to elapse.

## DEFROST TIMER WIRING

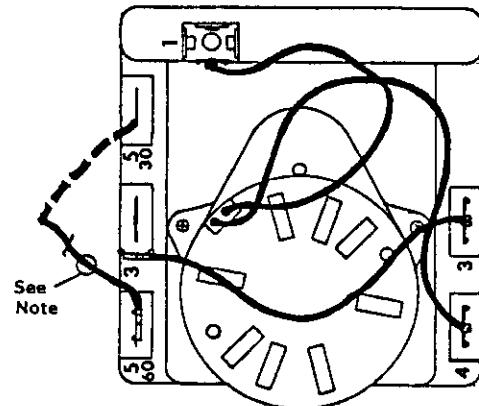

**NOTE:** All models are connected to 5/60 terminal (60 minute). Any model can be changed from 60 minutes to 30 minutes by unplugging from 5/60 terminal and reconnecting to 5/30 terminal as shown by dotted line.

## CRANKCASE HEATERS

All units are provided with some form of compressor crankcase heat. Some single phase units utilize the compressor motor start winding in series with a portion of the run capacitor to generate heat within the compressor shell to prevent liquid refrigerant migration.

Some three phase units utilize a wraparound type of crankcase heater that warms the compressor oil from the outside.

Some single and three phase models have an insertion well-type heater located in the lower section of the compressor housing. This is a self-regulating type heater that draws only enough power to maintain the compressor at a safe temperature.

Some form of crankcase heat is essential to prevent liquid refrigerant from migrating to the compressor, causing oil pump out on compressor start-up and possible valve failure due to compressing a liquid.

Refer to unit wiring diagram to find exact type of crankcase heater used.

The following decal is affixed to all outdoor units detailing start-up procedure. This is very important. Please read carefully.

**IMPORTANT**

THESE PROCEDURES MUST BE FOLLOWED AT INITIAL START-UP AND AT ANY TIME POWER HAS BEEN REMOVED FOR 12 HOURS OR LONGER.

TO PREVENT COMPRESSOR DAMAGE WHICH MAY RESULT FROM THE PRESENCE OF LIQUID REFRIGERANT IN THE COMPRESSOR CRANKCASE

1. MAKE CERTAIN THE ROOM THERMOSTAT IS IN THE OFF POSITION (THE COMPRESSOR IS NOT TO OPERATE).
2. APPLY POWER BY CLOSING THE SYSTEM DISCONNECT SWITCH THIS ENERGIZES THE COMPRESSOR HEATER WHICH EVAPORATES THE LIQUID REFRIGERANT IN THE CRANKCASE.
3. ALLOW 4 HOURS OR 60 MINUTES PER POUND OF REFRIGERANT\* IN THE SYSTEM AS NOTED ON THE UNIT RATING PLATE WHICHEVER IS GREATER.
4. AFTER PROPERLY ELAPSED TIME THE THERMOSTAT MAY BE SET TO OPERATE THE COMPRESSOR.
5. EXCEPT AS REQUIRED FOR SAFETY WHILE SERVICING — DO NOT OPEN SYSTEM DISCONNECT SWITCH.

7961 061

## IMPORTANT INSTALLER NOTE

For improved start-up performance, wash the indoor coil with a dishwasher detergent.

## SERVICE HINTS

1. Caution homeowner to maintain clean air filters at all times. Also, not to needlessly close off supply and return air registers. This reduces air flow through the system, which shortens equipment service life as well as increasing operating costs.
2. Switching to heating cycle at 75°F or higher outside temperature may cause a nuisance trip of the manual reset high pressure switch.
3. The heat pump wall thermostats perform multiple functions. Be sure that all function switches are correctly set for the desired operating mode before trying to diagnose any reported service problems.
4. Check all power fuses or circuit breakers to be sure that they are the correct rating.
5. Periodic cleaning of the outdoor coil to permit full and unrestricted air flow circulation is essential.

## COMPRESSOR CUT-OFF THERMOSTAT AND OUTDOOR THERMOSTATS

Heat pump compressor operation at outdoor temperatures below 0°F are neither desirable nor advantageous in terms of efficiency. Since most equipment at time of manufacture is not designated for any specific destination of the country, and most of the equipment is installed in areas not approaching the lower outdoor temperature range, the compressor cut offs are not factory installed.

Outdoor thermostats are available to hold off various banks of electric heat until needed as determined by outdoor temperature. The set point of either type of thermostat is variable with geographic region and sizing of the heating equipment to the structure. Utilization of the Heating Application Data and the heat loss calculation of the building are useful in determining the correct set points.

## COMPRESSOR CUT-OFF & OUTDOOR THERMOSTAT WIRING

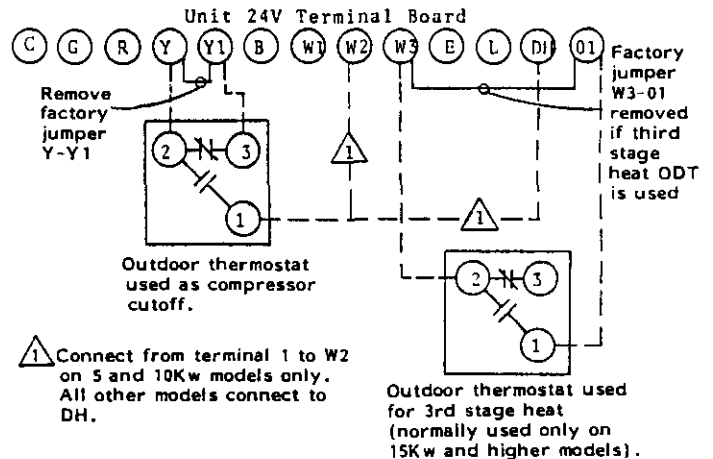

## 5-MINUTE COMPRESSOR TDR OPERATION

The time delay relay is a time delay device which will hold off the compressor contactor for a fixed time cycle of five minutes.

The application of such a device to an air conditioner or heat pump system is sometimes required because of repeated short-cycling of the equipment caused by "thermostat jiggling" or momentary power outages which occur quite frequently in some parts of the country due to weather conditions.

The time delay relay is a solid state device designed to allow the compressor contactor to operate on demand from the wall thermostat under normal conditions. As long as the "off" time of the air conditioner or heat pump system is longer than the delay period of the relay (five minutes), the compressor contactor will operate immediately. Once the contactor has been energized and then cycled off, for whatever reason, the relay will prevent the compressor contactor from operating until the nominal five minute period has elapsed.

## INSTALLATION

The time delay relay is mounted inside the control panel (refer to service parts section for mounting location). Disconnect the 24V wire (yellow) from the compressor contactor coil and reconnect to the TDR relay. Connect the yellow wire on the TDR relay to the compressor contactor coil (Figure 2.)

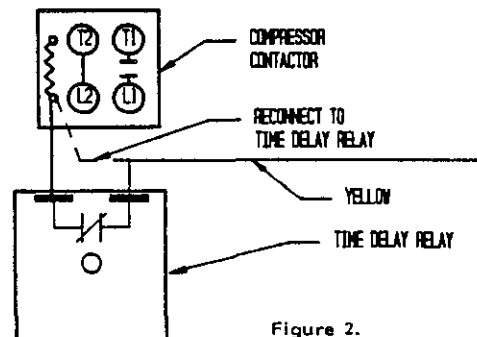
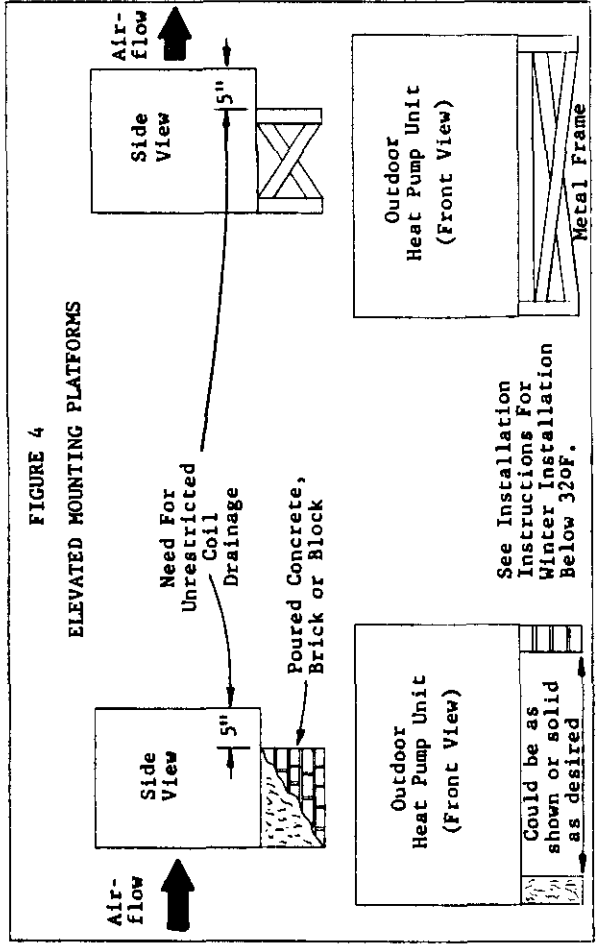
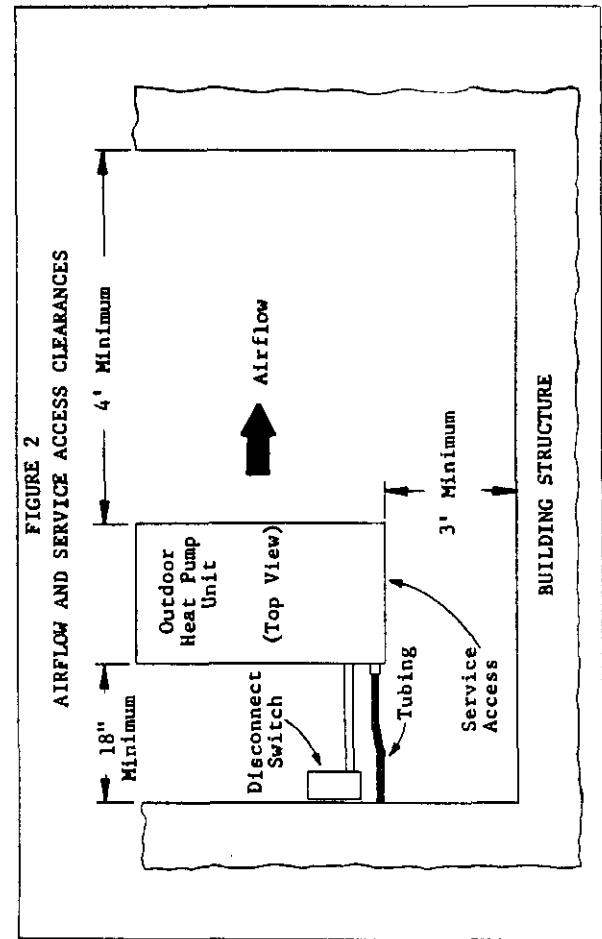
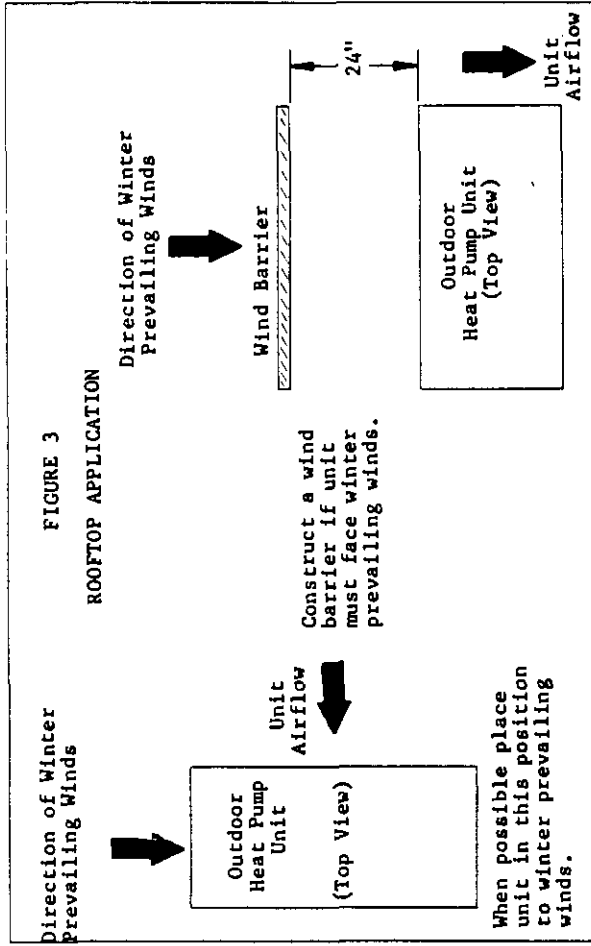
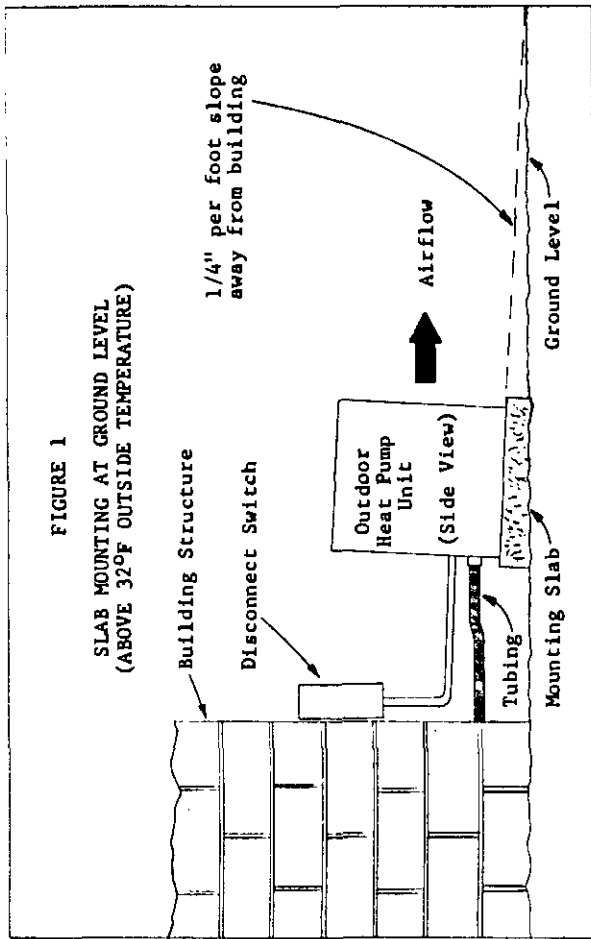

Figure 2.



## INSTALLING REFRIGERANT TUBING

**PRE-CHARGED TUBING** - Examine carefully the two lengths of pre-charged tubing furnished with the unit. The larger is the suction line. The smaller is the liquid line. The end of the tubing with the hex nut and gauge port is to be attached to the condensing unit.

Unroll the tubing, being careful not to kink, and install it between the condensing unit and the evaporator coil.

**CAUTION:** Be careful not to tear the insulation when pushing it through holes in masonry or frame walls.

When sealing tube opening in house wall use a soft material to prevent tube damage and vibration transmission.

Before fastening either end, use a tubing bender to make any necessary bends in the tubing. **AVOID EXCESSIVE BENDING IN ANY ONE PLACE TO AVOID KINKING.**

Start connecting the tubing at the evaporator coil end, first remove the protective caps and plugs from the quick-connect fittings on the evaporator coil and the pre-charged tubing. Inspect fittings and clean if necessary, making sure they are clear of foreign materials. If you clean the fittings, lubricate them with refrigeration oil. Connect both tubes to the fittings on the coil and draw up by hand.

When necessary to bend the insulated tube, suction line, cut the insulation around its circumference at a distance far enough beyond the point of the bend so as to clear the tubing bender.

Slip the insulation back together and vapor seal the joint with tape.

**NOTE:** The maximum distance for pre-charge tubing between the condenser and the evaporator is 45 feet.

**CAUTION:** Prior to connecting the pre-charged tubing to the evaporator coil or condensing unit, be sure all bends have been made, then coil any excess tubing in a horizontal plane, with the slope of the tubing toward the condensing unit.

**CAUTION:** Be sure to hold the coupling firmly to prevent movement of the coupling and tubing. Failure to do so could tear out the diaphragm causing a blockage of the system.

**CAUTION:** After starting to tighten up the fitting never try to back it off or take it apart.

For connecting the tubing at the condensing unit end, first remove the protective caps and plugs from the quick-connect fittings on the condensing unit and the pre-charged tubing. Inspect fittings and clean if necessary, making sure they are clear of foreign materials. If you clean the fittings, lubricate them with refrigeration oil. Connect both tubes to the fittings on the coil and draw up by hand.

Locate the gauge port in a 45° angle from a vertical up position so as to be accessible for gauge connections.

Use a wrench on the hex nut of the female fitting backing up the fitting with another wrench to keep tube from turning. Tighten the fittings together until they bottom out then tighten for an additional 1/4 turn so that coupling will seat properly.

Check the gauge port cap to make sure it is tight. If loose, tighten, being careful not to tighten too much as it will damage the valve in the gauge port.

Leak test all connections using an Electronic Leak Detector or a Halide Torch.

When tubing is installed in attica or drop ceiling, insulate the quick connect fitting on the larger tube thoroughly with 3/8" wall thickness, closed cell sponge tube insulation or equivalent. Failure to insulate will result in water damage to ceiling since the fitting will "sweat" and drop water on the ceiling.

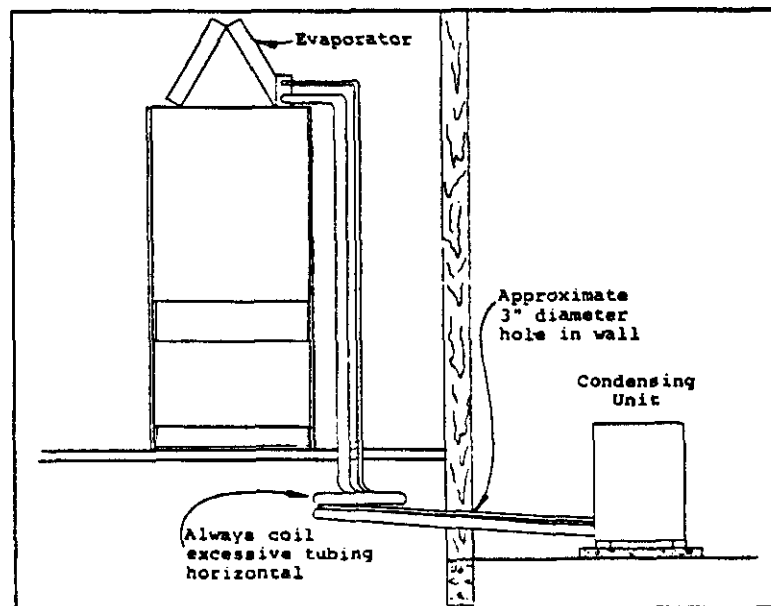

## R22 TOTAL SYSTEM CHARGE FOR SPLIT AIR CONDITIONING AND HEAT PUMP SYSTEMS

The following tables are used to determine the operating charge for split air conditioning and heat pump systems. The values shown are the total amount of refrigerant received in the precharged system components, which include the outdoor unit, indoor unit, and inter-connecting tubing. This is also the amount of refrigerant required for a system recharge following any refrigeration system repairs.

Find the outdoor section (and matching indoor section (Table A) and connecting tubing set (Table B) for system being used. Add the ounces of charge for each of the system components together. This value is the TOTAL SYSTEM CHARGE.

$$\begin{array}{ccccccc} \text{_____ OZs} & + & \text{_____ OZs} & + & \text{_____ OZs} & = & \text{_____ OZs} \\ \text{OUTDOOR UNIT} & & \text{INDOOR UNIT} & & \text{TUBING SET} & & \text{TOTAL SYSTEM CHARGE} \\ \text{(Table A)} & & \text{(Table A)} & & \text{(Table B)} & & \end{array}$$

To change total charge to lbs. and Ozs., divide by 16.

EXAMPLE: 37ECQ1 with 3ACQ3 and CT35 tubing set.

$$\text{_____ OZs} + \text{_____ OZs} + \text{_____ OZs} = \text{_____ OZs}$$

or  $\frac{\text{_____}}{16} = 5 \text{ lbs. } 2 \text{ oz.}$

TABLE B CHARGED TUBING SETS FOR USE WITH 18ECQ2, 24ECQ4, 18HPQ5, 24HPQ5				
Model	Charge	Length in Ft.	Liquid Line	Suction Line
CT15	2 oz.	15	1/4"	5/8"
RW25	3 oz.	25	1/4"	5/8"
RW35	7 oz.	35	1/4"	5/8"
RW45	11 oz.	45	1/4"	5/8"
FOR USE WITH 30ECQ4, 31ECQ2, 36ECQ5, 37ECQ1, WQS30, WQS36, WQSD30, WQSD36				
CTO	None*	0	3/8"	3/4"
CT15	2 oz.	15	1/4"	5/8"
CT25	3 oz.	25	1/4"	3/4"
CT35	14 oz.	35	3/8"	3/4"
CT45	20 oz.	45	3/8"	3/4"
FOR USE WITH 30HPQ6, 36HPQ7				
CTO	None*	0	3/8"	3/4"
CT15A	2 oz.	15	3/8"	5/8"
CT25A	8 oz.	25	3/8"	3/4"
CT35A	14 oz.	35	3/8"	3/4"
CT45A	20 oz.	45	3/8"	3/4"
FOR USE WITH 42ECQ1, 48ECQ2, 60ECQ1, 42HPQ4, 48HPQ5, 60HPQ5, WQS50, WQSD50				
CTO-12	None*	0	3/8"	7/8"
CT15-12	2 oz.	15	3/8"	7/8"
CT25-12	8 oz.	25	3/8"	7/8"
CT35-12	14 oz.	35	3/8"	7/8"
CT45-12	20 oz.	45	3/8"	7/8"

\*CTO and CTO-12 for field installed tubing. (See Table C for charging).

TABLE A

Model	Outdoor Unit Factory Charge	For Use With Indoor Unit	Indoor Unit Factory Charge
18HPQ5	46 oz.	H18QS1 H24QS1 B18EHQ1 B24EHQ1	7 oz. 7 oz. 7 oz. 7 oz.
24HPQ5	53 oz.	H18QS1 H24QS1 B18EHQ1 B24EHQ1	7 oz. 7 oz. 7 oz. 7 oz.
30HPQ6	73 oz.	A36AQ-A <sup>1</sup> B30EHQ B36EHQ1	8 oz. 2 oz. 8 oz.
37HPQ7	88 oz.	A36AQ-A <sup>1</sup> B36EHQ1	8 oz. 8 oz.
42HPQ4	88 oz.	H4AQ1 BC48A	23 oz. 23 oz.
48HPQ5	122 oz.	H4AQ1 H5AQ1 BC48A BC60A	23 oz. 43 oz. 23 oz. 43 oz.
60HPQ5	112 oz.	H5AQ1 BC60A	43 oz. 43 oz.

<sup>1</sup> When using A36AQ-A with 30HPQ6 or 36HPQ7 total system charge must be increased by 8 oz.

In the event that the installer is running his own tubing by using a CTO kit or is modifying a precharged tubing set by adding or subtracting a few feet of tubing length, the tubing set should be evacuated and charged before being connected to the outdoor and indoor section. To determine TUBING SET ONLY charges, use the following table:

TABLE C (Shows Charge in Ozs.)												
	Tubing Set Length in Ft.	10	15	20	25	30	35	40	45	50	55	60
RW Series	1/4" O.D. Liquid Line	2	2	3	3	5	7	9	11	--	--	--
CT Series	3/8" O.D. Liquid Line	2	2	5	8	11	14	17	20	23	26	29

To determine a TOTAL SYSTEM CHARGE for a system that is connected with a non-standard tubing length, the outdoor basic charge (from Table A) plus the indoor unit basic charge (from Table A), is added to the tube set based on liquid line O.D. size (Table C). This value is the TOTAL SYSTEM CHARGE.

NOTE: If your tubing length is between the sizes shown in the table, use a charge value appropriately between the values shown for the tubing length shorter and longer than actual length.



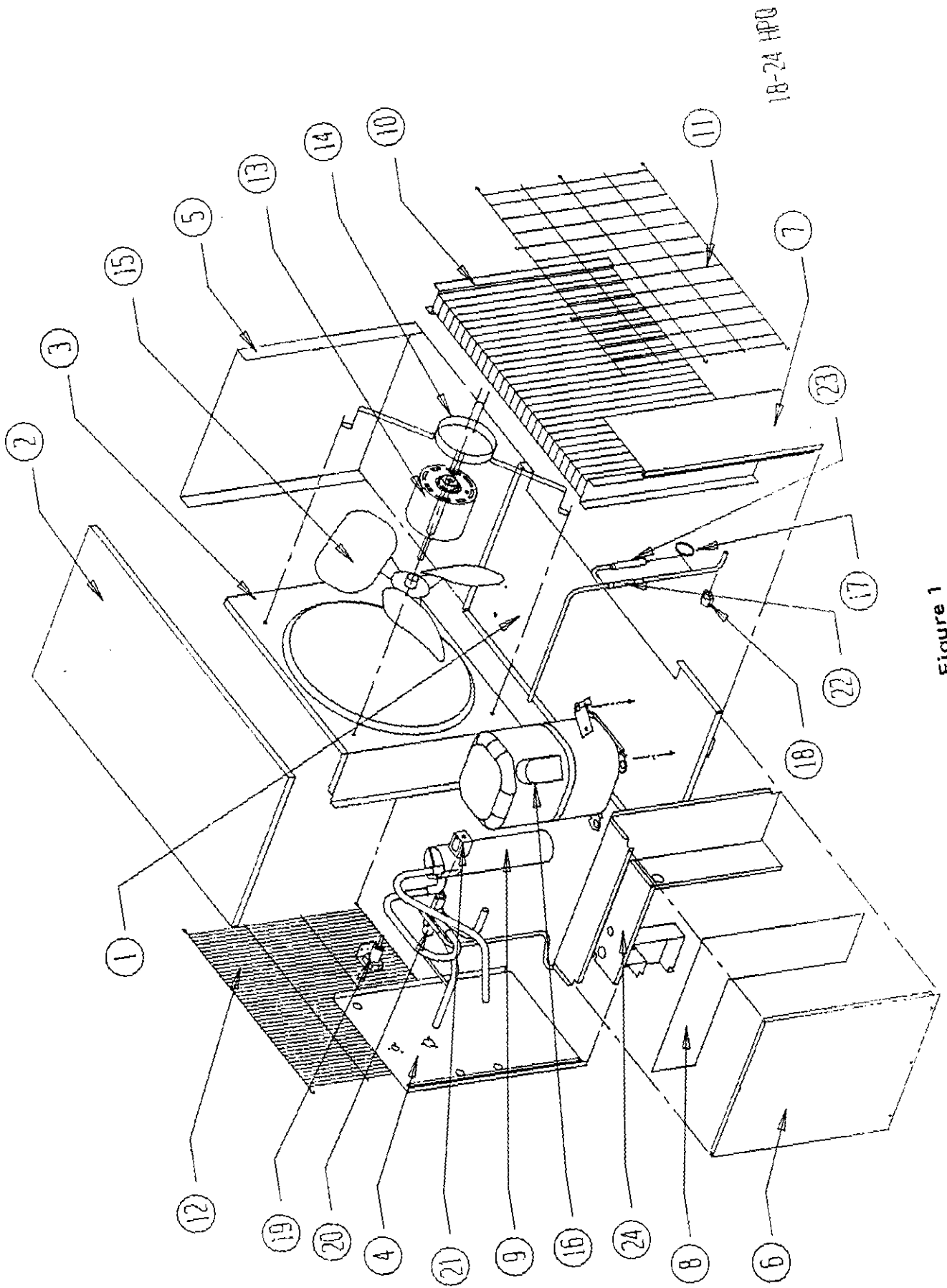

Figure 1

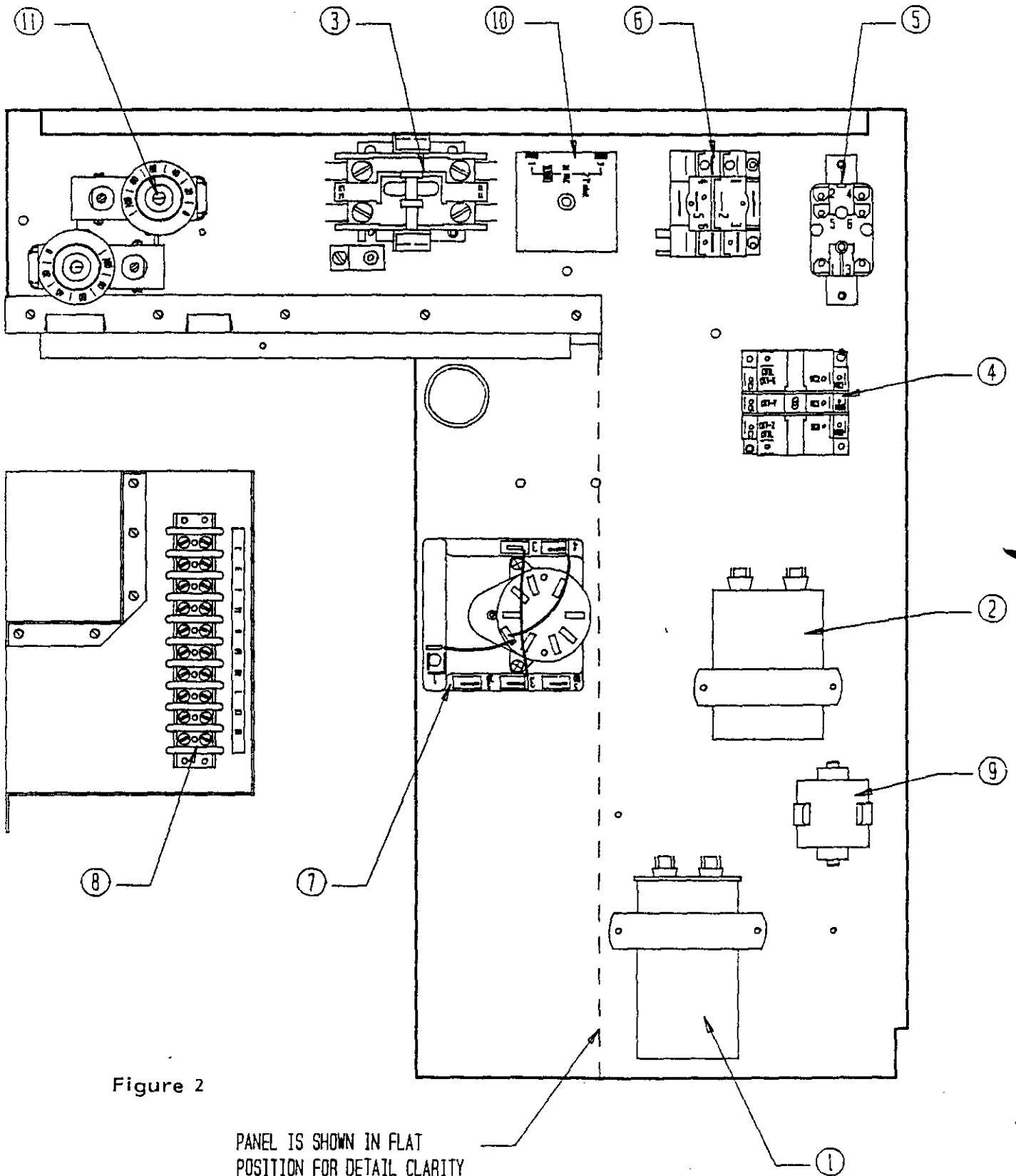

Figure 2

PANEL IS SHOWN IN FLAT  
POSITION FOR DETAIL CLARITY

18-24 HPD CONTROL PANEL

PARTS LIST  
SPLIT SYSTEM HEAT PUMPS

Item	Part No.	Description	18HPQ5	24HPQ5
Basic Unit Parts List Fig. 1				
1	127-016	Base	x	x
2	106-015	Top	x	x
3	124-005	Fan Shroud	x	x
4	148-027	Corner--Compressor	x	x
5	100-122	Side	x	x
6	152-014	Door - Compressor Access	x	x
7	148-037	Corner - Condenser	x	x
8	132-020	Control Panel Cover	x	x
9	5202-003	Accumulator	x	x
10	5051-008	Condenser Coil	x	x
11	7051-009	Condenser Grille	x	x
12	7051-010	Inlet Grille	x	x
13	8103-008	Motor - Fan 1/5	x	x
14	8200-001	Motor Mount - Fan	x	x
15	5151-001	Fan Blade TF1839	x	x
16	8000-010	Compressor AW5517F	x	
16	8000-101	Compressor H23B223ABC		x
17	5811-033	Capillary Tube - Heat	1	
17	5811-034	Capillary Tube - Heat		1
18	8408-017	Defrost Thermostat	x	x
19	8406-010	High Pressure Switch	x	x
20	5650-005	Reversing Valve	x	x
21	5650-008	Solenoid Coil	x	x
22	5651-036	Check Valve	x	x
23	5210-002	Strainer	x	x
24	*	Control Panel *See control panel drawing	x	x
Control Panel Parts List Fig. 2				
1	8552-045	Capacitor 30/370		x
1	8552-027	Capacitor 25/370	x	
2	8552-002	Capacitor 5/370	x	x
3	8401-007	Contactator - Comp 25A	x	x
4	8201-047	Relay Defrost	x	x
5	8201-015	Relay - Emergency Heat	x	x
6	8201-024	Relay - Compressor Fault	x	x
7	8612-012	Defrost Timer	x	x
8	8607-011	Terminal Board	x	x
9	SKI09		Field Ins.	Field Ins.
10	CGAH-4	5 Min. Time Delay	Field Ins.	Field Ins.
11	8408-008	Outdoor Thermostat	Field Ins.	Field Ins.
	4026-110	Wiring Diagram	x	x

**18HPQ5**

**COOLING**

AIR TEMPERATURE ENTERING OUTDOOR COIL DEGREE F.

Indoor Section	Return Air Temperature	Pressure	75	80	85	90	95	100	105	110	115	
B18EHQ1 Rated CFM 625	75° D.B. 62° W.B.	Low Side	59	62	65	68	70	72	74	76	77	
		High Side	179	194	209	224	240	256	271	287	303	
	80° D.B. 67° W.B.	Low Side	63	67	70	73	75	77	79	81	82	
		High Side	184	199	214	230	246	261	278	294	311	
H18Q51 Rated CFM 625	85° D.B. 72° W.B.	Low Side	68	72	75	78	81	83	85	87	88	
		High Side	190	206	222	238	255	271	288	305	322	
	B24EHQ1 Rated CFM 635	75° D.B. 62° W.B.	Low Side	69	71	72	74	75	77	79	80	82
			High Side	184	199	213	228	244	259	275	291	308
80° D.B. 67° W.B.		Low Side	74	76	77	79	81	82	84	86	88	
		High Side	189	204	219	234	250	266	282	299	315	
H24Q51 Rated CFM 635	85° D.B. 72° W.B.	Low Side	80	82	83	85	87	88	90	92	95	
		High Side	196	211	226	242	258	274	291	308	326	

**HEATING**

AIR TEMPERATURE ENTERING OUTDOOR COIL DEGREE F.

Indoor Section	Return Air Temp	Pressure	0	5	10	15	17	20	25	30	35	40	45	47	50	55	60	
B18EHQ1 Rated CFM 625	H18Q51 Rated CFM 625	70° D.B.	Low Side	17	21	26	30	32	35	39	44	48	52	57	58	61	65	70
			High Side	144	150	157	165	168	173	181	191	200	210	220	225	231	243	255
B24EHQ1 Rated CFM 635	H24Q51 Rated CFM 635	70° D.B.	Low Side	10	17	24	30	32	35	40	44	47	50	52	53	54	55	56
			High Side	112	127	141	153	158	164	173	181	187	191	195	195	196	197	198
		70° D.B.	Low Side															
			High Side															
		70° D.B.	Low Side															
			High Side															

Low side pressure + 2 PSIG (suction line between accumulator + compressor)  
 High side pressure +5 PSIG (liquid line @ outdoor unit quick connect)

Tables are based upon rated CFM (airflow) across the evaporator coil and should be found under section titled "Refrigerant Charge" elsewhere in manual. If there is any doubt as to correct operating charge being in the system, the charge should be removed, system evacuated, and recharged to serial plate instructions.

**24HPQ5**

**COOLING**

AIR TEMPERATURE ENTERING OUTDOOR COIL DEGREE F.

Indoor Section	Return Air Temperature	Pressure	75	80	85	90	95	100	105	110	115
			H18QS1 Rated CFM 730	75° D.B. 62° W.B.	Low Side	58	60	62	64	66	68
	High Side	209	224		239	254	270	284	299	315	329
B18EHQ1 Rated CFM 730	80° D.B. 67° W.B.	Low Side	62	64	66	68	71	73	75	78	80
		High Side	215	230	246	261	277	292	307	323	388
	85° D.B. 72° W.B.	Low Side	67	69	71	73	76	78	81	84	86
		High Side	222	238	255	270	287	302	317	334	349
B24EHQ1 Rated CFM 800	75° D.B. 62° W.B.	Low Side	65	67	70	72	74	76	77	78	80
		High Side	205	221	237	253	268	283	300	316	332
	80° D.B. 67° W.B.	Low Side	69	72	74	77	79	81	83	84	85
H24QS1 Rated CFM 765		High Side	210	227	243	259	275	291	308	324	341
	85° D.B. 72° W.B.	Low Side	74	77	80	83	85	87	89	90	91
		High Side	217	235	251	268	285	301	319	335	353

**HEATING**

AIR TEMPERATURE ENTERING OUTDOOR COIL DEGREE F.

Indoor Section	Return Air Temp	Pressure	0	5	10	15	17	20	25	30	35	40	45	47	50	55	60	
			H18QS1 Rated CFM 730	B18EHQ1 Rated CFM 730	70° D.B.													
			Low Side +2 PSIG	14	18	22	26	28	30	35	39	43	47	51	53	55	60	64
			High Side +5 PSIG	145	156	167	177	182	188	200	209	220	231	241	246	252	263	273
B24EHQ1 Rated CFM 800	H24QS1 Rated CFM 765	70° D.B.																
			Low Side	16	20	24	28	30	32	36	40	44	49	53	55	58	61	63
			High Side	136	144	152	159	163	166	173	180	188	196	204	208	211	215	219

Low side pressure + 2 PSIG (suction line between accumulator + compressor)  
 High side pressure +5 PSIG (liquid line @ outdoor unit quick connect)

Tables are based upon rated CFM (airflow) across the evaporator coil and should be found under section titled "Refrigerant Charge" elsewhere in manual. If there is any doubt as to correct operating charge being in the system, the charge should be removed, system evacuated, and recharged to serial plate instructions.

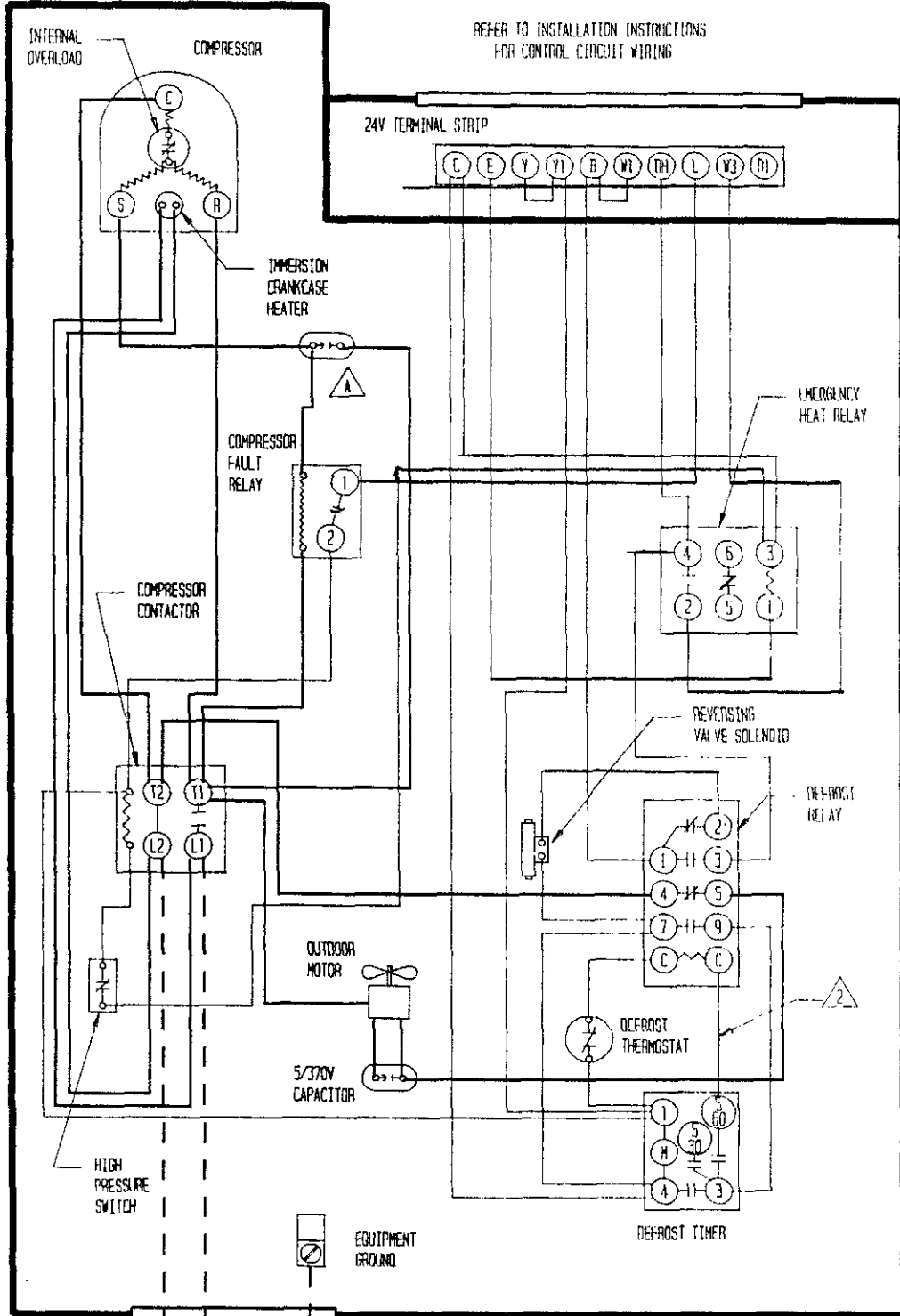

USE COPPER CONDUCTORS ONLY

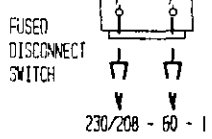

	FACTORY WIRING	FIELD WIRING
Low Voltage	—	---
High Voltage	---	---

2 RECONNECT FROM 5-60 TO 5-30 FOR 30 MINUTE CYCLE.

CHART A

MODEL	CAPACITOR
18HP05	25/370
24HP05	30/370