

# **INSTALLATION INSTRUCTIONS**

## **ECONOMIZER**

### **MODEL**

### **ECR-5**

**FOR USE WITH BARD 3-1/2 thru 5 TON  
ROOF MOUNT AIR CONDITIONERS  
AND HEAT PUMPS**

MANUAL 2100-137 REV. A  
SUPERSEDES REV. NONE  
FILE VOL. II, TAB 13



INSTALLATION INSTRUCTIONS  
FOR  
ECONOMIZER MODEL ECR-5 FOR USE WITH BARD 3½ AND 5  
TON ROOF MOUNT AIR CONDITIONERS AND HEAT PUMPS

GENERAL INFORMATION

The economizer should only be installed by a trained heating and air conditioning technician. These instructions serve as a guide to the technician installing the economizer package. They are not intended as a step by step procedure with which the mechanically inclined owner can install the package.

The economizer is shipped in one carton which contains the intake hood subassembly, return/outside air damper subassembly, filters, top filter rack assembly, electrical harness, gasketing, miscellaneous hardware and installation instructions. The economizer installation requires an additional two stage cooling thermostat in place of the normal single stage cooling thermostat. Also additional low voltage wire will be required to transmit the second call (Y2) for cool, i.e., use 6 conductor thermostat wire for air conditioning units and 9 conductor thermostat wire for heat pumps.

UNPACKING

Upon receipt of the equipment be sure to compare the model number found on the shipping label with the accessory identification information on the ordering and shipping document to verify that the correct accessory has been shipped.

Inspect the carton housing on each economizer as it is received, and before signing the freight bill, verify that all items have been received and that there is no visible damage. Note any shortages or damage on all copies of the freight bill. The receiving party must contact the last carrier immediately, preferably in writing, requesting inspection by the carrier's agent. Concealed damage not discovered until after loading must be reported to the carrier within 15 days of its receipt.

## DESCRIPTION

The ECR-5 economizers are designed to be used with Bard 3½ and 5 ton roof mount series air conditioners and heat pumps. They are electro-mechanical economizer systems designed to provide "free" cooling where the outdoor air temperature is cool enough to provide the needed cooling without running the compressor. When cooling is needed, the system automatically takes advantage of the cold outdoor air when available and uses it for first stage cooling. This then reduces the need to run the air conditioning compressor providing lower operating costs and increasing the service life of the equipment. If the outdoor air gets too warm or humid to be helpful, the enthalpy control detects the condition and automatically closes the outdoor air damper, opens the return air damper and switches to the compressor operation. This is all done automatically to achieve maximum savings without attention from the user. See Figure A for a block diagram of the economizer operation logic flow.

**Figure A**  
**Economizer Operation for**  
**Single-Compressor Units**

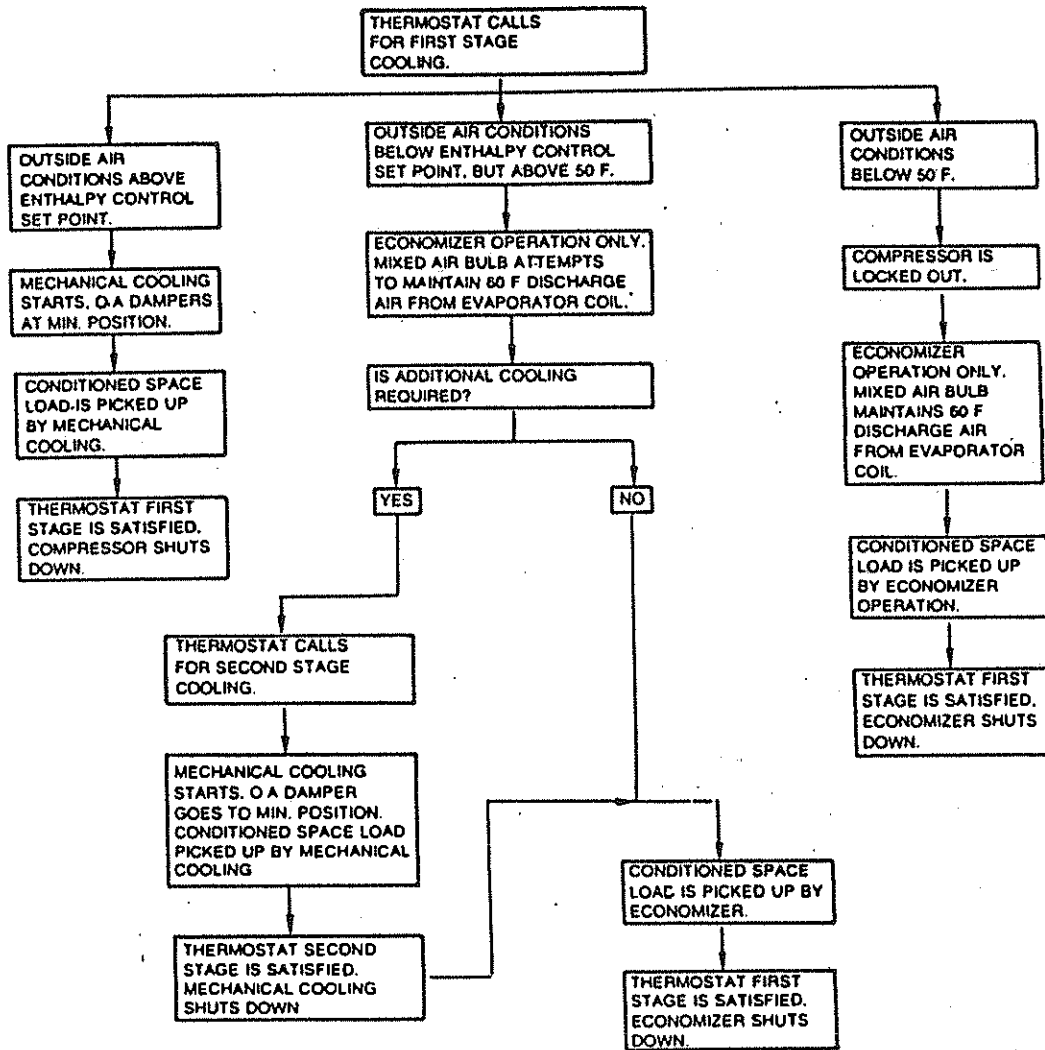

## BASIC INSTALLATION

1. Unpack the economizer assembly which includes: (1) intake hood subassembly, (2) return/outside air damper subassembly, (3) electrical harness, (4) filters, (5) top filter rack subassembly, (6) gasketing, (7) miscellaneous hardware and installation instructions. (See Figure 1)

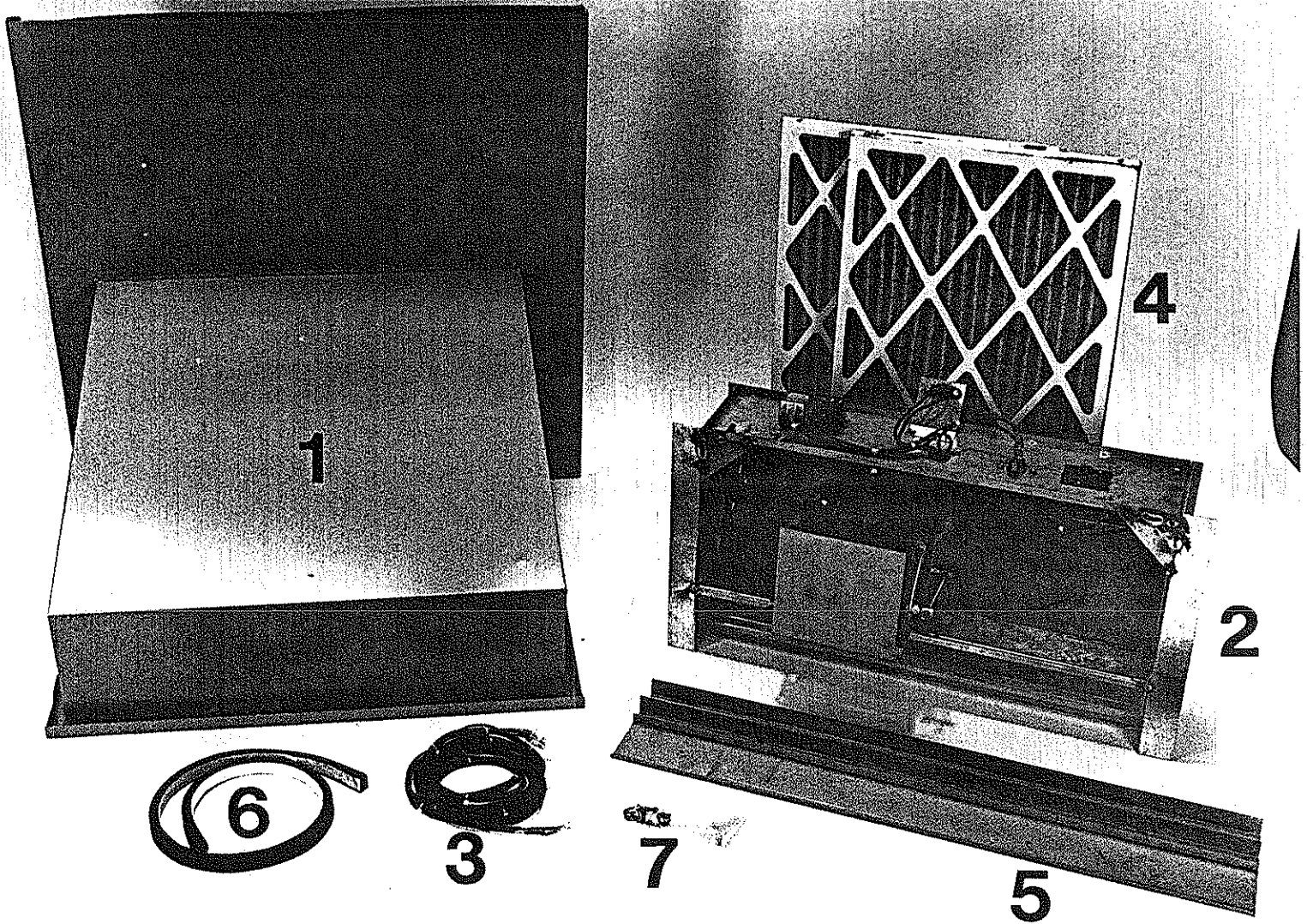

Figure 1.

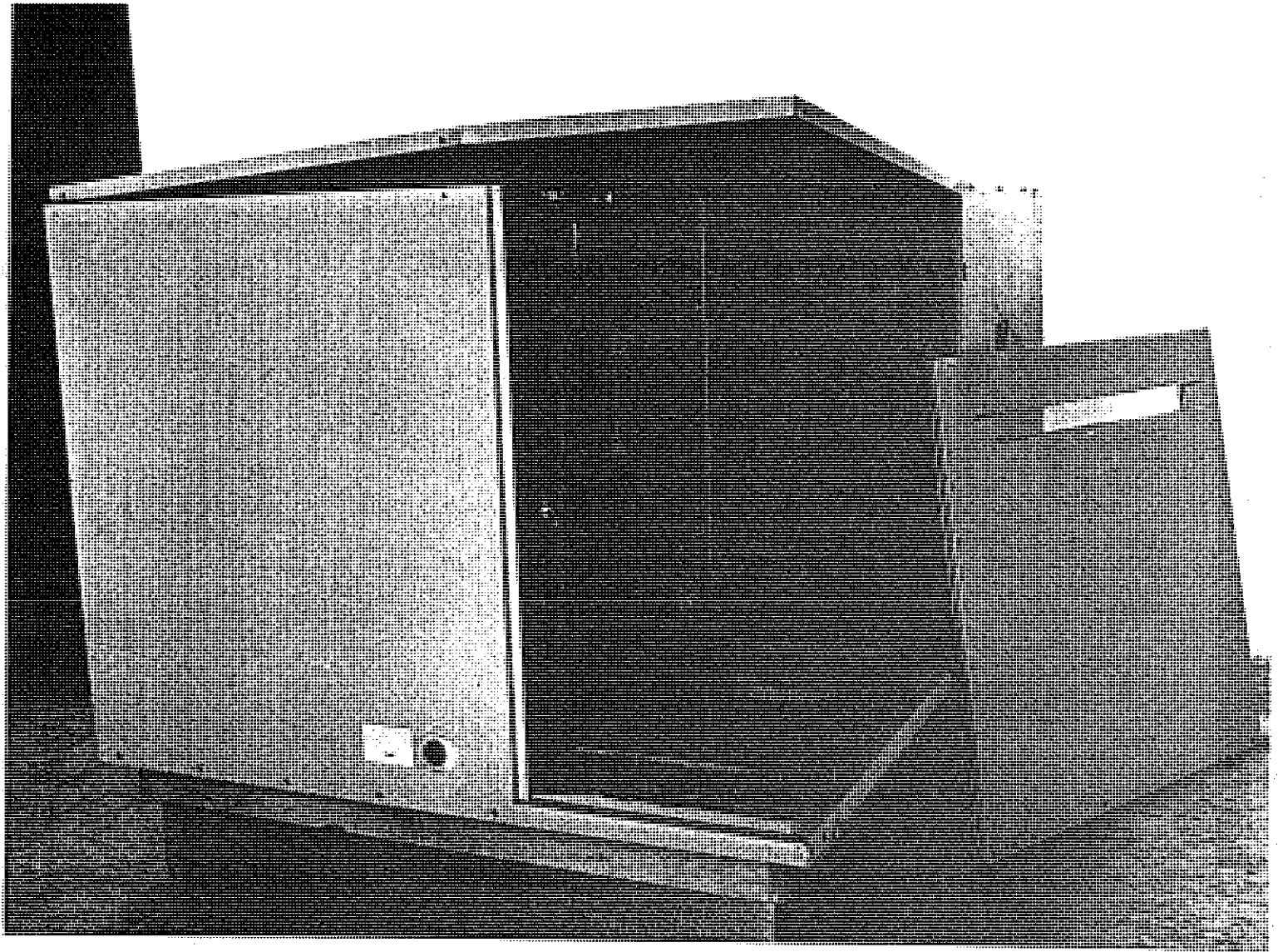

Figure 2.

**WARNING:** Open and lock unit disconnect switch before installing this accessory to prevent injury or death due to electrical shock or contact with moving parts. Turn the thermostat to off.

2. Remove the existing exterior filter access panel, blower access panel, manual fresh air intake and control panel on the Bard RPM 042 to 060 unit. Save all screws to resecure panels.
3. Remove and discard the existing unit return air filters.
4. Remove the hex head screw in the unit, which is located above the condensate drain, that secures the top to the side wall. Save this screw to resecure top.
5. Raise the free corner of the top taking care not to damage (bend or buckle) it. (See Figure 2) Slide the top filter rack subassembly into the unit over the evaporator coil. Position the rack over the coil as shown in Figure 3.

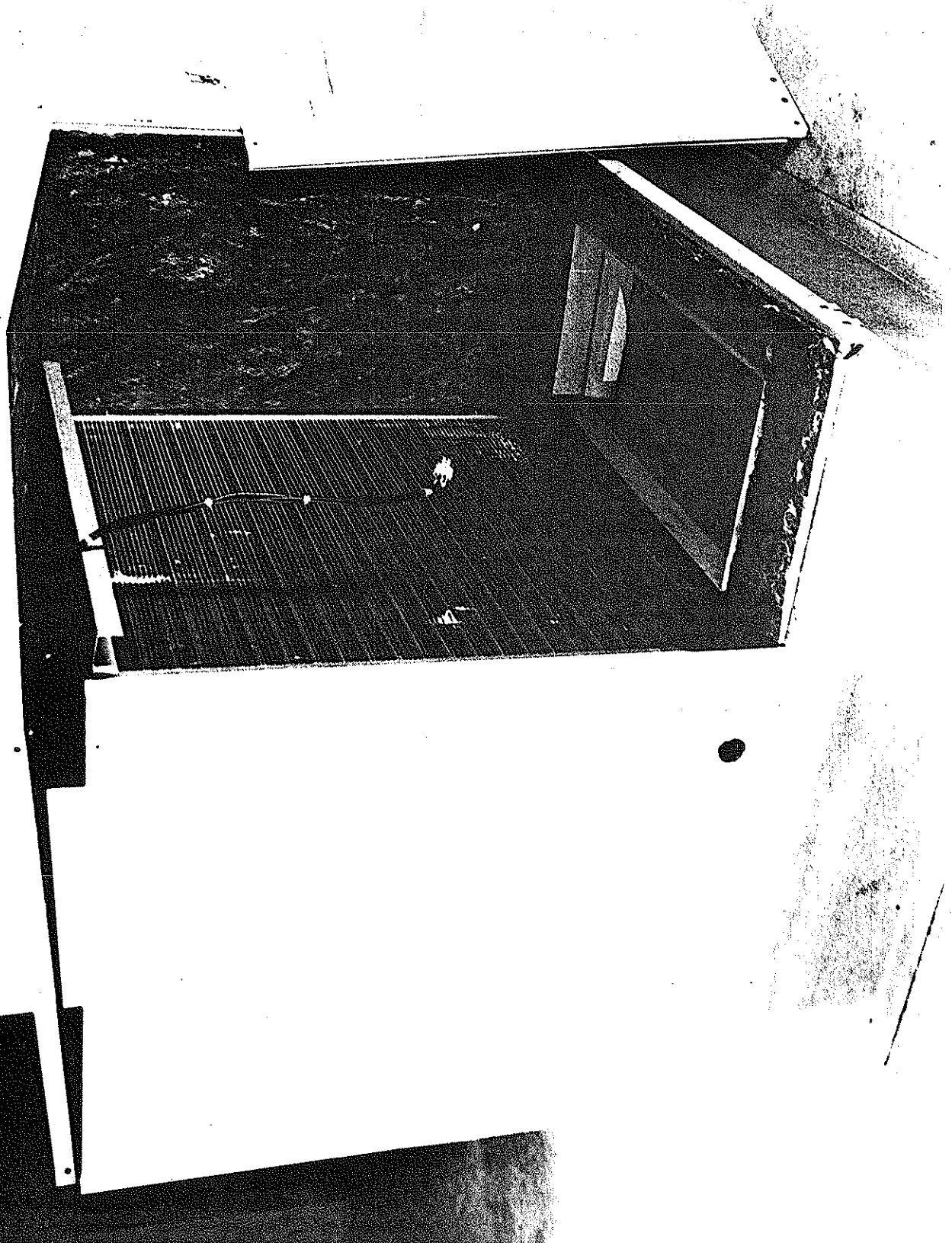

Figure 3.



6. Route the wiring harness over the top filter rack subassembly through the blower compartment, through the existing 7/8" diameter snap bushing located in the side of the unit control box, through the control box, through the snap bushing and into the low voltage terminal block section. Attach wires to the terminal block as per wiring wiagram. (Figure 4)

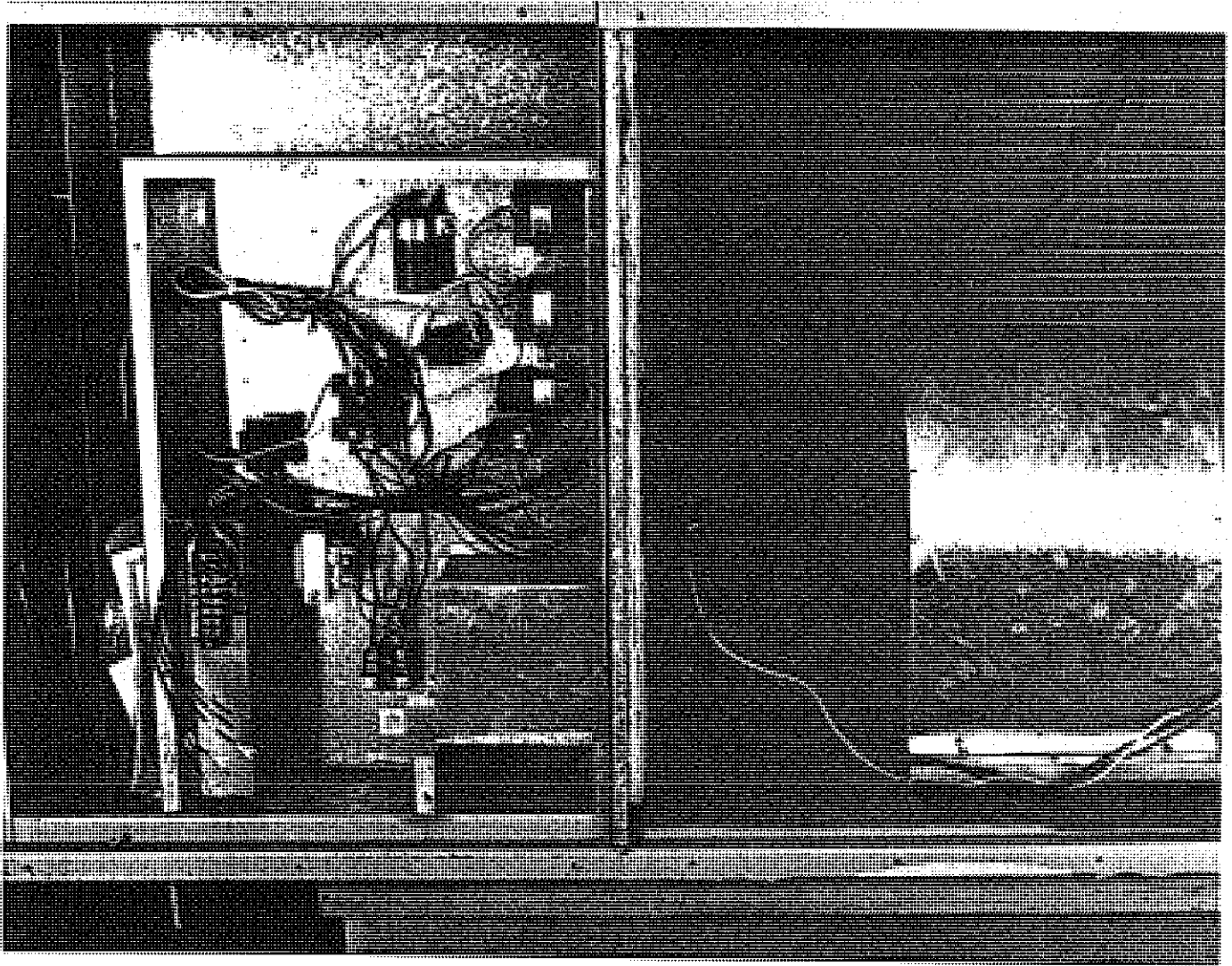

Figure 4

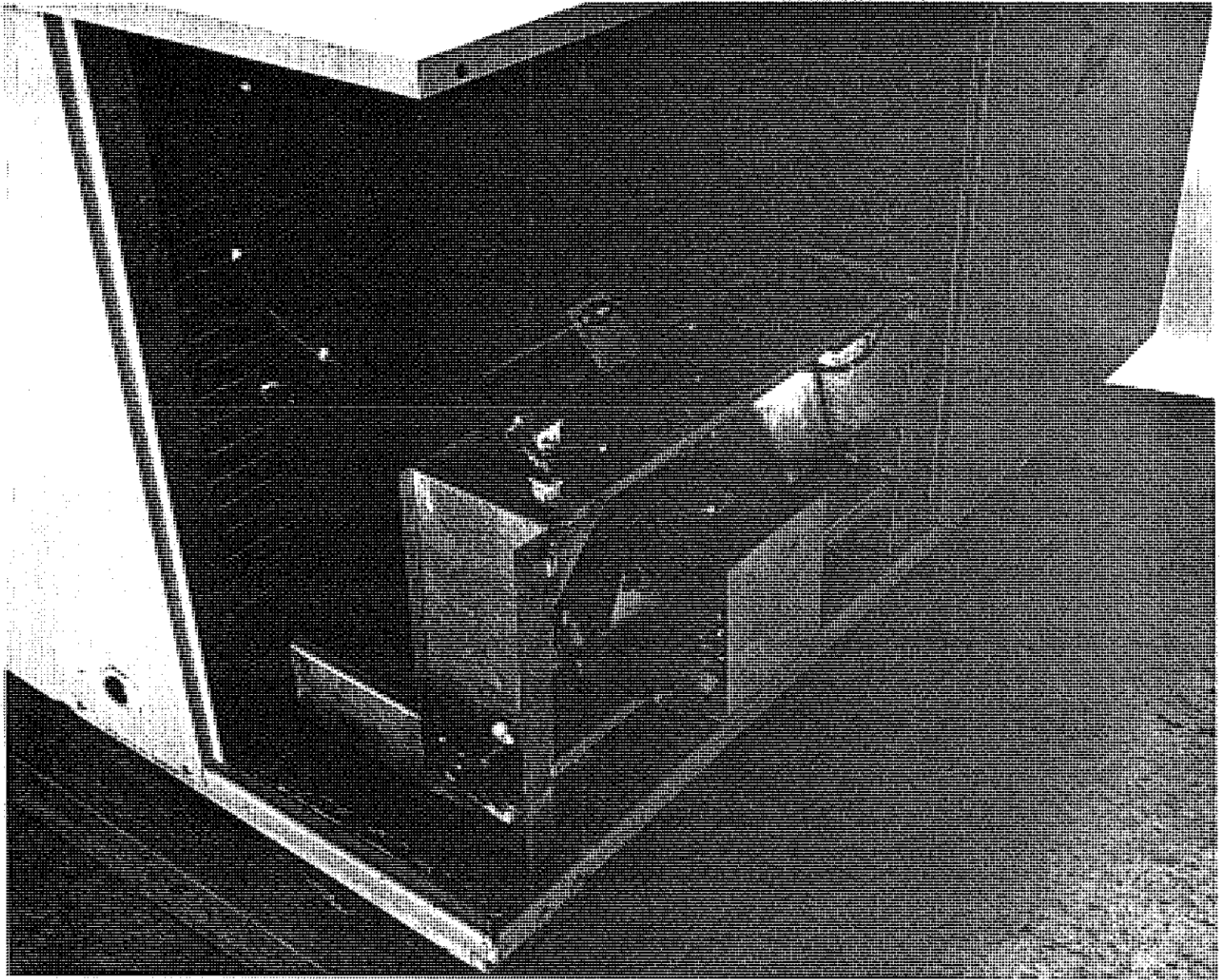

Figure 5.

7. Install the return/outside damper subassembly in the unit by placing it over the return air opening flange flush with the unit base pan. (Figure 5)
8. Connect the male six pin connector on the end of the harness into the mating female receptacle on top of the damper subassembly. (Figure 5)
9. Retract the excess harness length into the blower compartment and secure it to the suction line using the wire ties supplied with the economizer hardware package.

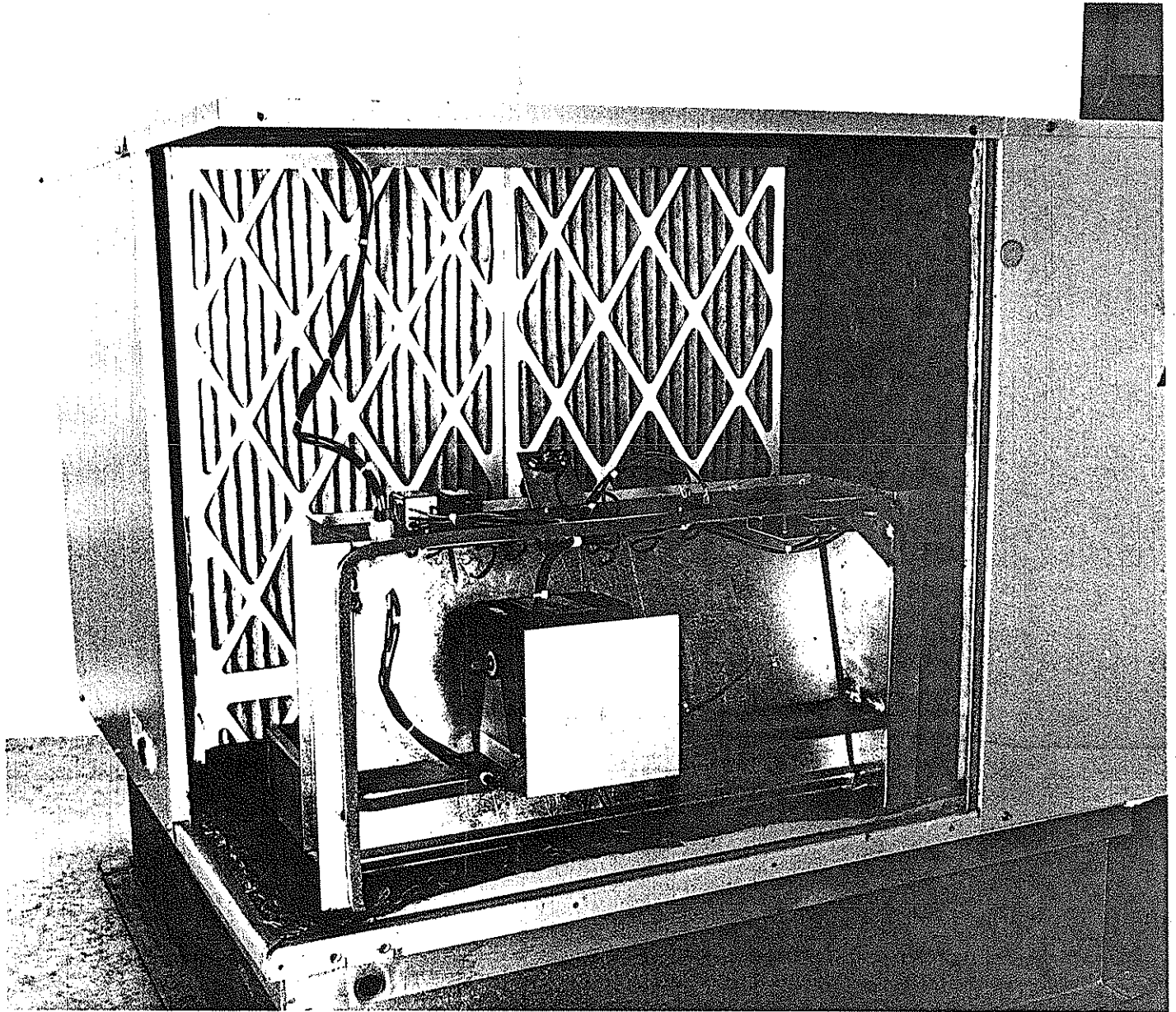

Figure 6.

10. Lower the top back into position and secure with the hex head screw removed in step 4.
11. Install the Farr 30/30 throwaway filters in rack. Take care to place them in the rack with the arrows on the filter rack in the direction of air flow (towards coil). (See Figure 6)
12. Replace the blower access and electrical access panels on the unit and reconnect power.

### 13. ECONOMIZER CHECKOUT

- a. Remove the motor shield by removing the hex head screws in the motor base, to allow access to control adjustments.
- b. Remove the access plate on the motor (see enclosed manufacturer's literature) located above wiring terminals. (Figure 7)

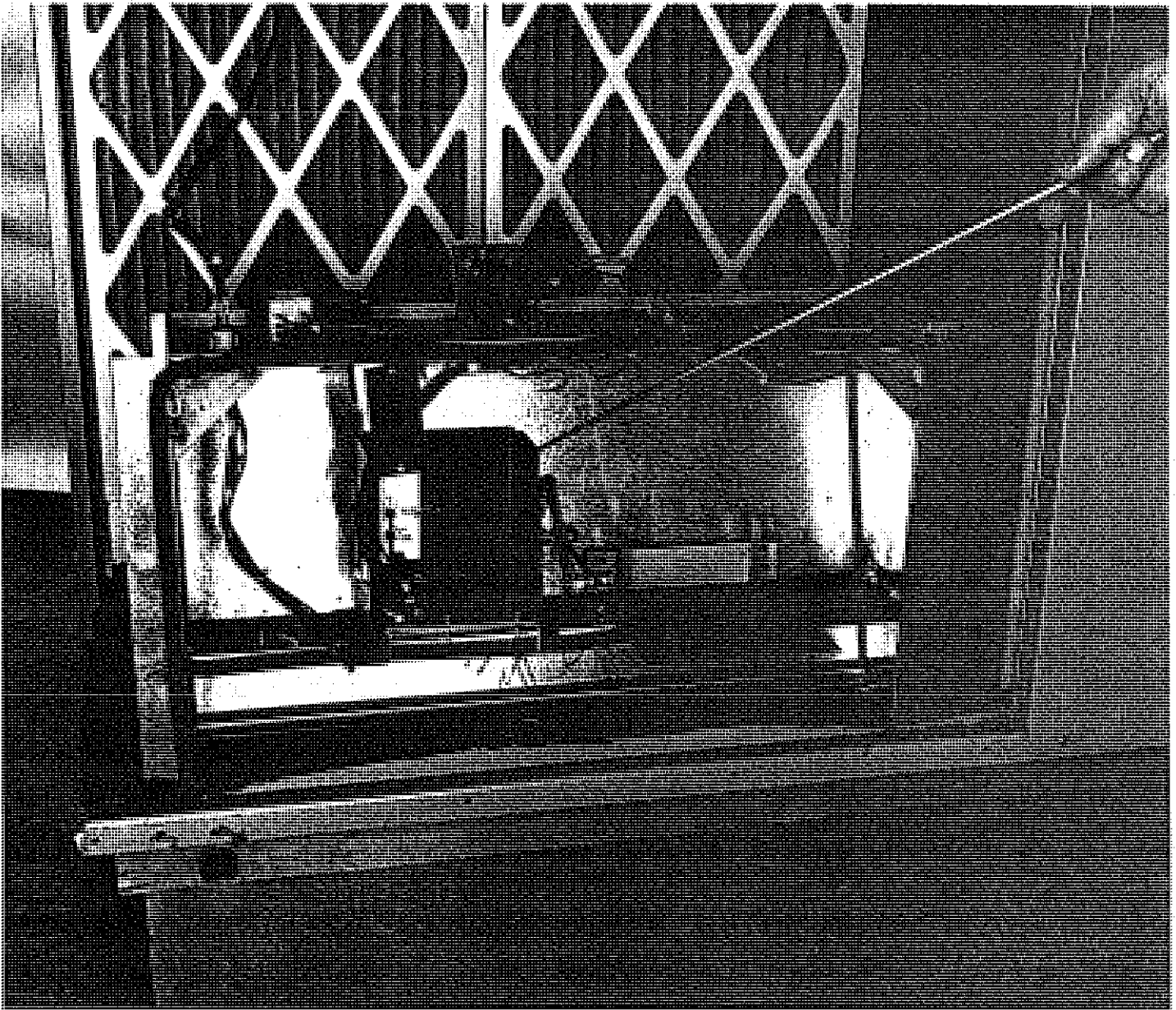

Figure 7.

- c. Energize the evaporator blower by switching the thermostat to the manual fan position with the heat/cool switch in the off position.
- d. Cycle the minimum position potentiometer full closed to full open. Throughout checkout procedure observe operation of damper to insure there is free, unobstructed operation through the entire range of damper travel. Then adjust the damper minimum open position to meet local codes or application requirements. (See example below)

Example: Minimum fresh air intake calculation for 10 percent fresh air.

1. Measure return air temperature (RAT) (assume 75°F for example).
2. Measure outdoor air temperature (OAT) (assume 60°F for example).
3. Calculate the mixed air temperature (MAT) which will result from the desired combination of OAT (10 percent) and RAT (90 percent).

$$.1 \text{ OAT} + .9 \text{ RAT} = \text{MAT}$$

or substituting example values

$$.1 (60^\circ\text{F}) + .9 (75^\circ\text{F}) = 73.5^\circ\text{F}$$

4. Adjust the minimum position potentiometer knob until proper mixed air temperature as calculated above is reached. Care should be taken to insure thermometer is sensing air that is well mixed.
  5. Mark correct setting on dial of minimum position potentiometer for future reference.
- e. Adjust mixed air potentiometer (factory set at 55°F) to insure desired temperature to meet local codes or application criteria. (Do not confuse this with the MAT calculated above).

This is the temperature of fresh air cooling desired when unit is in economizer mode and is typically desired to be 55°F to 60°F).

- f. Replace the motor access plate and shield and secure with proper screws.
- g. Adjust the enthalpy control to position A,B,C,D (Figure 8) to achieve the maximum combination of temperature and humidity acceptable for the installation as per the chart in manufacturer's enclosed instructions. (The suggested setting is between A & B 70°DB @ 55 percent RH).
- h. Switch the thermostat fan control to automatic and position the heat cool switch to cool. Adjust the thermostat temperature to engage the first stage of cooling only (Y1). This will cause the dampers to modulate to achieve the previously set mixed air temperature provided outside air enthalpy is sufficiently low. If enthalpy is too high for economizing, low enthalpy can be simulated by temporarily removing and jumping leads on terminal 2 and 3 of enthalpy control together. This will also cause the economizer damper to modulate away from minimum position (be sure to properly reconnect leads at end of checkout procedure).
- i. Readjust temperature on the thermostat to engage the second stage of cooling (Y2). The damper motor should return to the previously set minimum position.
- j. Switch thermostat to off fan and off heat/cool positions to de-energize unit. Economizer damper should return to full closed (100 per cent return air) position. Checkout is complete.

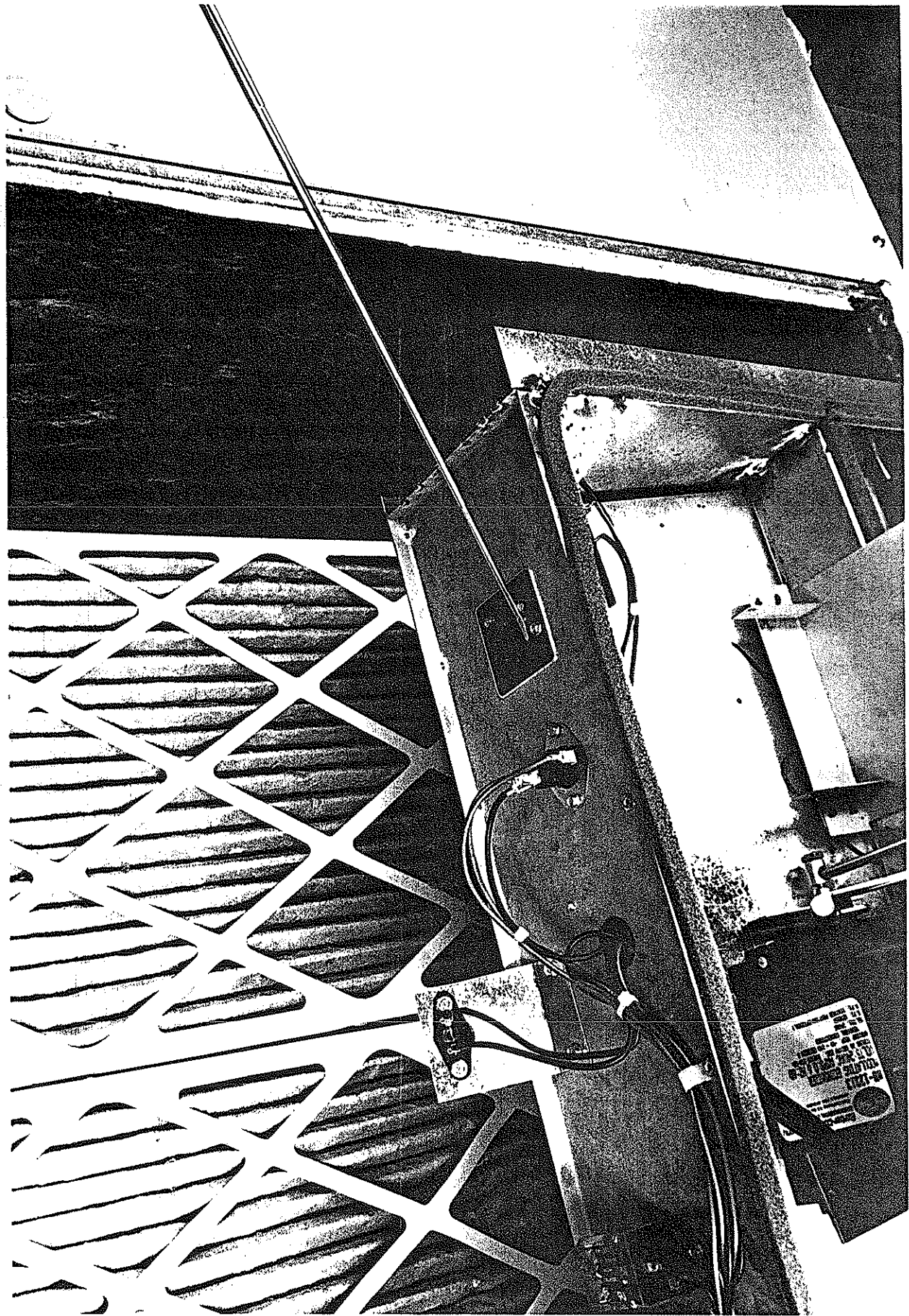

Figure 8

14. Gasket outside/return air damper assembly with adhesive backed gasketing provided in hardware package on surfaces as shown in Figure 6.
15. Install the intake hood subassembly on unit side replacing the unit manual fresh air intake panel and secure with hex head sheet metal screws. (See Figure 9)
16. Install the unit filter access panel removed in step 2 and secure with quarter turn fasteners in panel.
17. Economizer is now ready for operation.

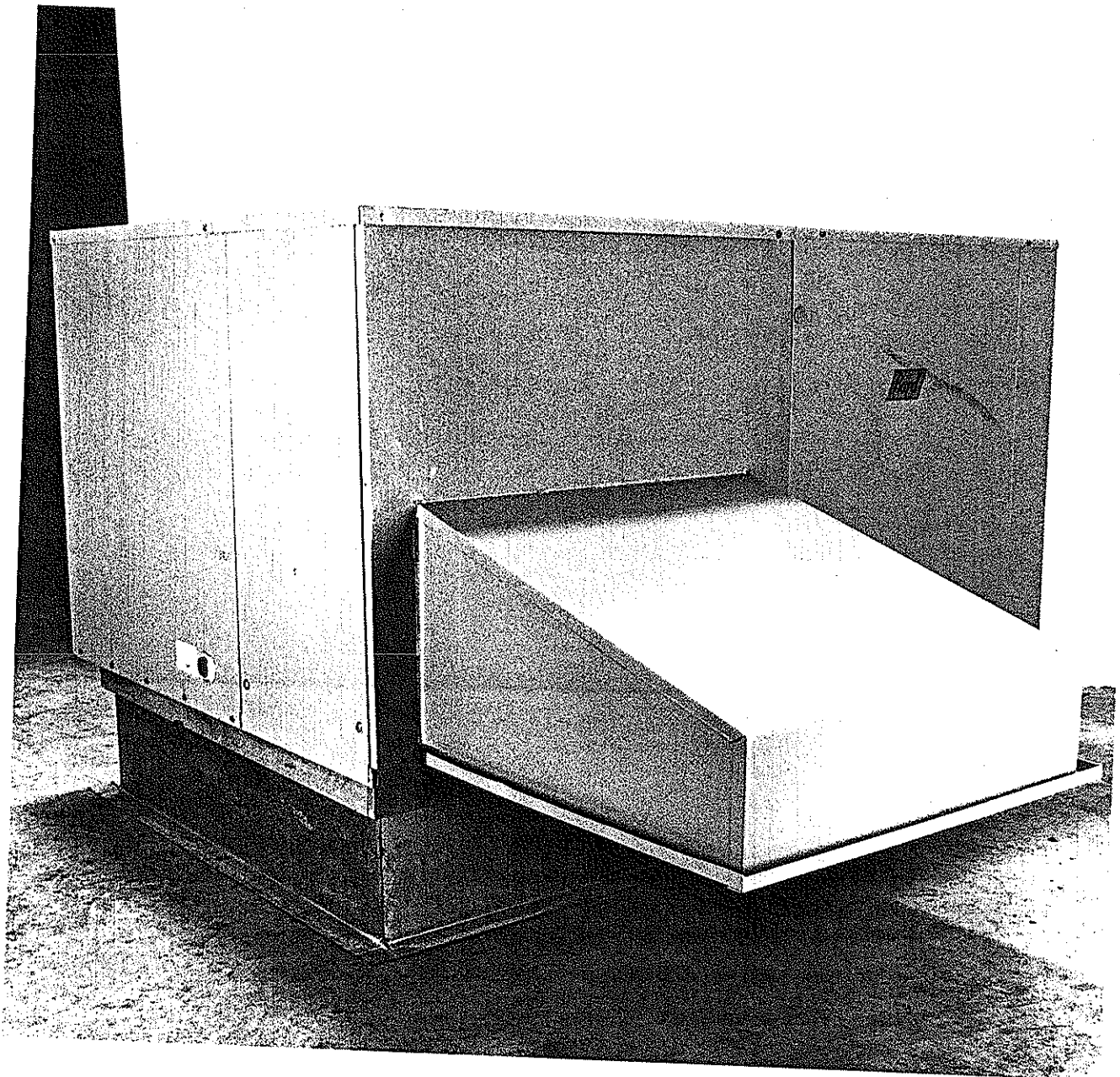
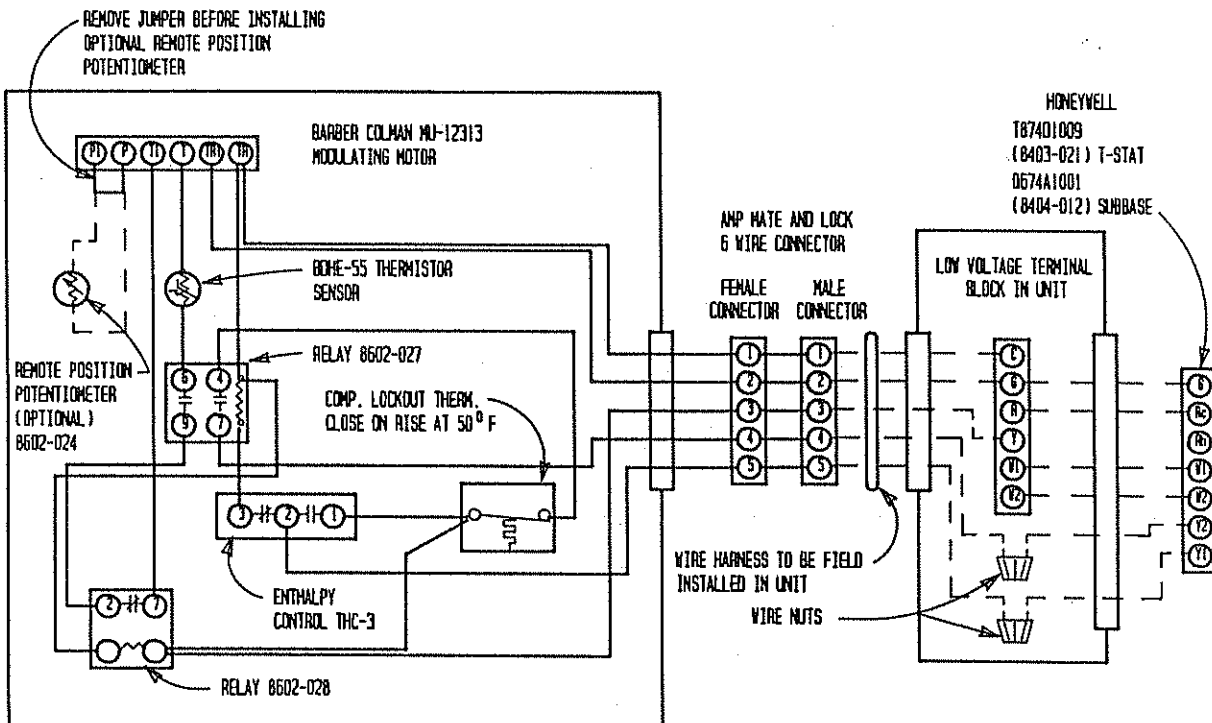

Figure 9.





24V FACTORY WIRING ———  
24V FIELD WIRING - - - - -

AIR CONDITIONER CONNECTION DIAGRAM

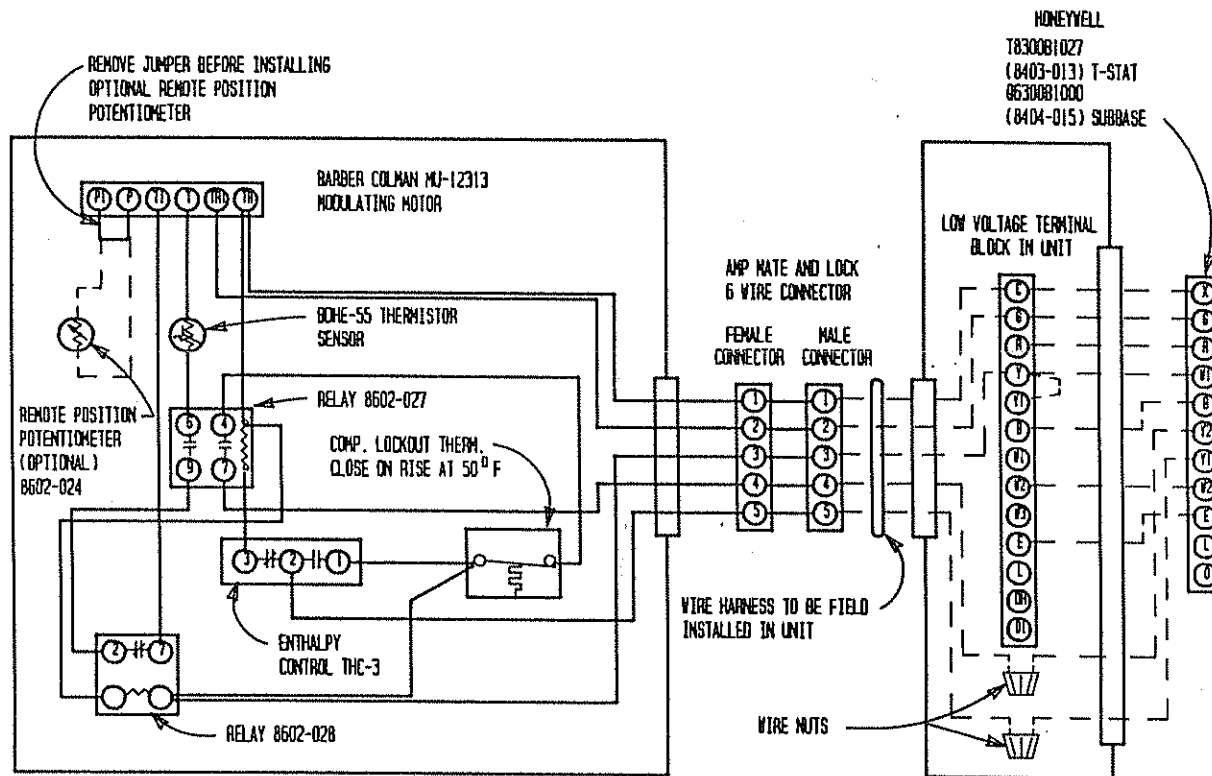

24V FACTORY WIRING ———  
24V FIELD WIRING - - - - -

HEAT PUMP CONNECTION DIAGRAM