

INSTALLATION INSTRUCTIONS

WALL MOUNTED PACKAGE HEAT PUMPS

MODELS

30WH6

36WH7

INDEX

Important	2
Shipping Damage	2
General	2
Installation	2
Duct Work	2
Filter	2
Fresh Air Intake	3
Wall Mounting	3
Wiring--Main Power	3
Wiring--24V Control Circuit	4
Condensate Drain	4
Compressor Malfunction Relay (Single Phase Models Only)	4
Pressure Service Ports	4
Sequence of Operation	4
Compressor Cut-Off Thermostat and Outdoor Thermostats	5
Compressor Cut-Off and Outdoor Thermostat Wiring	5
Heat Anticipation	5
Thermostat Indicator Lamps	5
Emergency Heat Posisiton	5
Defrost Cycle	6
Service Hints	7
Important Installer Note	7
Crankcase Heaters	7
Fan Blade Setting Dimensions	10
Refrigerant Charge	10
Compressor Cut-Off and Outdoor Thermostat Wiring	12

INDEX OF FIGURES AND TABLES

Figure 1	1
Figure 2	4
Figure 3	6
Figure 4	7
Figure 5	8
Figure 6	9
Figure 7	10
Figure 8	12
Figure 9	12
Table 1	1
Table 2	5
Table 3	10
Table 4	11
Table 5	11
Table 6	13
Table 7	13

ELECTRICAL SPECIFICATIONS

TABLE I

Model	Rated Volts & Phase	Max. Unit Amps @ 240/208V	No. Field Power Circuit	Internal Fuses		② Max. Ext. Fuse or Circuit Breaker		③ Min. Circuit Ampacity		No. Field Power Ckts.	② Max. Ext. Fuse or Circuit Breaker			③ Min. Circuit Ampacity		
				Ckt. A	Ckt. B	Ckt. A	Ckt. B	Ckt. A	Ckt. B		Ckt. A	Ckt. B	Ckt. C	Ckt. A	Ckt. B	Ckt. C
30WH6-A00*	230/208	16.2/18.2	1			40		27		1	40			27		
05*	1	37/36.3	1			60		49		1	60			49		
10* ①		57.8/54.4	1	60/30		80		75		2	60	30		49	26	
15*		64.7/56.3	1	60/60		90		81		2	60	60		49	52	
30WH6-B00*	230/208	13.0/14.4	1			25		18		1	25			18		
09*	3	34.7/33.2	1			45		45		1	45			45		
36WH7-A00*	230/208	22.2/25.2	1			50		31		1	50			31		
05*	1	43/43.3	1			60		57		1	60			57		
10* ①		63.8/61.4	1	60/30		90		83		2	60	30		57	26	
15*		64.7/61.4	1	60/30		90		83		2	60	60		57	52	
36WH7-B00*	230/208	18.7/20.7	1			40		25		1	40			25		
09*	3	40.4/38.4	1			60		53		1	60			53		
15* ①		40.4/38.4	1			60		53		1	60			53		
36WH7-C00*	460	10	1			15		15		1	15			15		
09*	3	20.8	1			30		29		1	30			29		
15* ①		20.8	1			30		29		1	30			29		

* - N for standard models (less circuit breakers).

- C for models with circuit breakers.

- ① Maximum KW that can operate with heat pump on.
- ② Maximum size of the time delay fuse or HACR type circuit breaker for protection of field wiring conductors. (Sizes 70 amp or greater are not HACR type).
- ③ These "Minimum Circuit Ampacity" values are to be used for sizing the field power conductors. Refer to the National Electric Code (latest revision) article 310 for power conductor sizing. Caution: When more than one field power conductor circuit is run thru one conduit, the conductors must be derated. Pay special attention to note 8 of tables 310 regarding Ampacity Adjustment Factors when more than 3 conductors are in a raceway.
- ④ All wiring must conform to the National Electrical Code and all local codes.

FIGURE 1

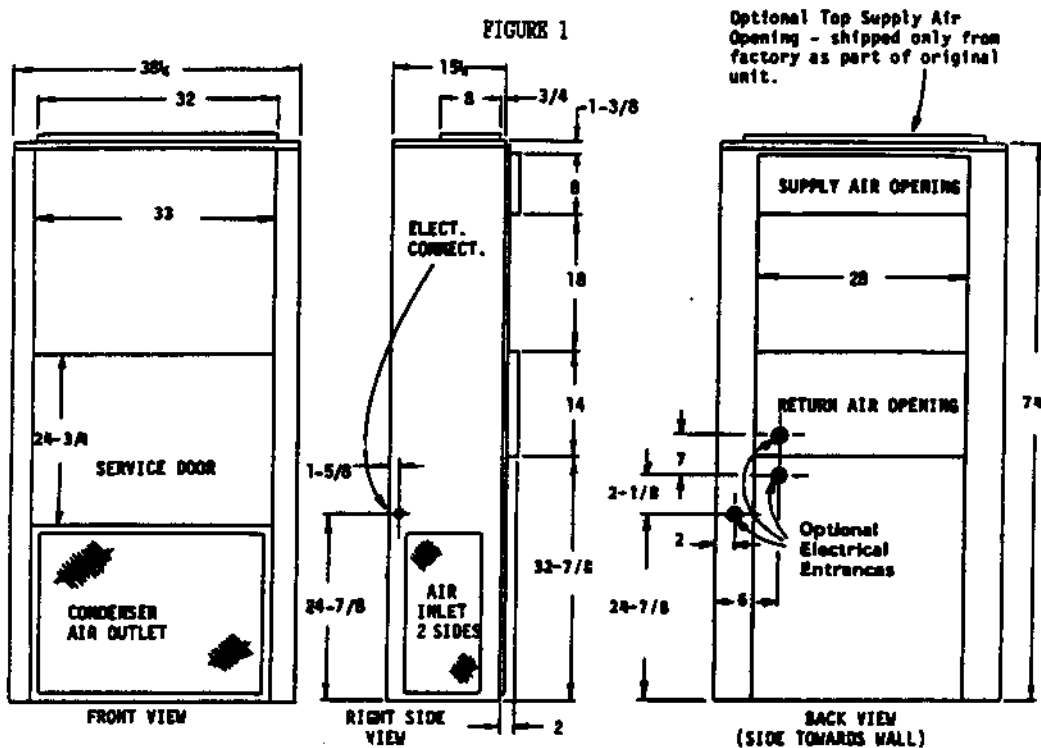

IMPORTANT

The equipment covered in this manual is to be installed by trained, experienced service and installation technicians. Any heat pump is more critical of proper operating, charge and an adequate duct system than a straight air conditioning unit. All duct work supply and return, must be properly sized for the design air flow requirement of the equipment. ACCA is an excellent guide to proper sizing. All duct work or portions thereof not in the conditioned space should be properly insulated in order to both conserve energy and prevent condensation or moisture damage.

SHIPPING DAMAGE

Upon receipt of equipment, the carton should be checked for external signs of shipping damage. If damage is found, the receiving party must contact the last carrier immediately, preferably in writing, requesting inspection by the carrier's agent.

GENERAL

The refrigerant system is completely assembled and charged. All internal wiring is complete.

The unit is designed for use with or without duct work. Flanges are provided for attaching the supply and return ducts.

These instructions explain the recommended method to install the air cooled self-contained unit and the electrical wiring connections to the unit.

These instructions and any instructions packaged with any separate equipment required to make up the entire air conditioning system should be carefully read before beginning the installation. Note particularly "Starting Procedure" and any tags and/or labels attached to the equipment.

While these instructions are intended as a general recommended guide, they do not supersede any national and/or local codes in any way. Authorities having jurisdiction should be consulted before the installation is made.

INSTALLATION

Size of unit for a proposed installation should be based on heat loss calculation made according to methods of Air Conditioning Contractors of America (ACCA). The air duct should be installed in accordance with the Standards of the National Fire Protection Association for the Installation of Air Conditioning and Ventilating systems of Other Than Residence Type, NFPA No. 90A, and Residence Type Warm Air Heating and Air Conditioning Systems, NFPA No. 90B. Where local regulations are at a variance with instructions, installer should adhere to local codes.

DUCT WORK

Design the duct work according to methods given by the Air Conditioning Contractors of America. When duct runs through unheated spaces, it should be insulated with a minimum of one inch of insulation. Use insulation with a vapor barrier on the outside of the insulation. Flexible joints should be used to connect the duct work to the equipment in order to keep the noise transmission to a minimum.

A one-inch clearance to combustible material for the first three feet of duct attached to the outlet air frame is required see page 9 for further details.

FILTER

A one inch throwaway filter is supplied with each unit. The filter slides into position making it easy to service. This filter can be serviced from the outside by removing the service door.

FRESH AIR INTAKE

All units are built with a fresh air inlet hole punched in the service panel. The fresh air damper assembly is shipped with each unit, and must be attached at the installation site. See Figure 6 for typical installation procedure.

The fresh air damper assembly is standard equipment with the unit because of the variety of state or local codes requiring fresh air capability.

All capacity, efficiency and cost of operation information as required for Department of Energy "Energyguide" Fact Sheets is based upon the fresh air blank-off plate in place and is recommended for maximum energy efficiency.

The blank-off plate is available upon request from the factory and is installed in place of the fresh air damper shipped with each unit.

WALL MOUNTING

1. Two holes, for the supply and return air openings must be cut through the wall as shown in Figure 6.
2. On wood-frame walls, the wall construction must be strong and rigid enough to carry the weight of the unit without transmitting any unit vibration. **WARNING:** Fire hazard can result if one inch clearance to combustible materials for supply air duct is not maintained. See Figure 6.
3. Concrete block walls must be thoroughly inspected to insure that they are capable of carrying the weight of the installing unit.
4. Ducts through the walls must be insulated and all joints taped or sealed to prevent air or moisture entering the wall cavity.
5. Some installations may not require any return air duct. It is recommended that on this type of installation that a filter grille be located in the wall. Filters must be of sufficient size to allow a maximum velocity of 400 FPM.

NOTE: If no return air duct is used, applicable installation codes may limit this cabinet to installation only in a single story structure.

WIRING--MAIN POWER

Refer to the unit rating plate for wire sizing information and maximum fuse or "BACR Type" circuit breaker size. Each outdoor unit is marked with a "Minimum Circuit Ampacity". This means that the field wiring used must be sized to carry that amount of current. Depending on the installed KW of electric heat, there may be two field power circuits required. If this is the case, the unit serial plate will so indicate. Some models are suitable only for connection with copper wire, while others can be wired with either copper or aluminum wire. Each unit and/or wiring diagram will be marked "Use Copper Conductors Only" or "Use Copper or Aluminum Conductors." These instructions **MUST BE** adhered to. Refer to the National Electrical Code for complete current carrying capacity data on the various insulation grades of wiring material.

The electrical data lists fuse and wire sizes (60 degree C copper) for all models, including the most commonly used heater sizes. Also shown are the number of field power circuits required for the various models with heaters.

Field conduit connections must be to the control box and not terminate at the cabinet.

The unit rating plate lists a "Maximum Time Delay Relay Fuse" or "BACR Type" circuit breaker that is to be used with the equipment. The correct size must be used for proper circuit protection and also to assure that there will be no nuisance tripping due to the momentary high starting current of the compressor motor.

WIRING--24V CONTROL CIRCUIT

Nine (9) wires should be run from thermostat subbase to the 24V terminal board in the unit. A nine conductor, 18 gauge copper, color-coded thermostat cable is recommended. The connection points are shown on most of the wiring diagrams and are also shown below.

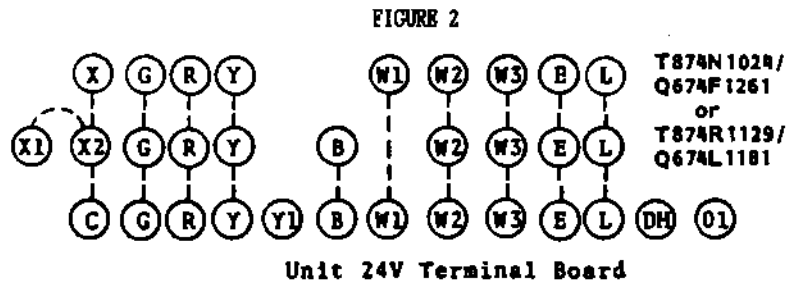

IMPORTANT NOTE: Only the thermostat and subbase combinations as shown above will work with this equipment. The thermostat and subbase **MUST** be matched, and the correct operation can be assured only by proper selection and application of these parts.

CONDENSATE DRAIN

A plastic drain hose extends from the drain pan at the top of the unit down to the unit base. There are openings in the unit base for the drain hose to pass through. In the event the drain hose is connected to a drain system of some type, it must be an open or vented type system to assure proper drainage.

COMPRESSOR MALFUNCTION RELAY (Single Phase Models Only)

Actuation of the green "check" lamp is accomplished by a voltage type relay which is factory installed. Any condition such as loss of charge, defective capacitor, defective contactor, etc., that will prevent compressor from operating will cause green lamp to activate. This is a signal to the operator of the equipment to place system in emergency heat position.

PRESSURE SERVICE PORTS

High and low pressure service ports are installed on all units so that the system operating pressures can be observed. Pressure curves can be found later in the manual covering all models on both cooling and heating cycles. It is imperative to match the correct pressure curve to the unit by model number.

SEQUENCE OF OPERATION

COOLING--Circuit R-Y makes at thermostat pulling in compressor contactor, starting the compressor and outdoor motor. The G (indoor motor) circuit is automatically completed on any call for cooling operation, or can be energized by manual fan switch on subbase for constant air circulation.

HEATING--A 24V solenoid coil on reversing valve controls heating cycle operation. Two thermostat options, one allowing "Auto" changeover from cycle to cycle and the other constantly energizing solenoid coil during heating season and thus eliminating pressure equalization noise except during defrost, are to be used. On "Auto" option, a circuit is completed from R-W1 and R-Y on each heating "on" cycle, energizing reversing valve solenoid and pulling in compressor contactor starting compressor and outdoor motor. R-G also make starting indoor blower motor. Heat Pump heating cycle now in operation. The second option has no "Auto" changeover position, but instead energizes the reversing valve solenoid constantly whenever the system switch on subbase is placed in "Heat" position, the "B" terminal being constantly energized from R. A thermostat demand for heat completes R-Y circuit, pulling in compressor contactor starting compressor and outdoor motor. R-G also make starting indoor blower motor.

COMPRESSOR CUT-OFF THERMOSTAT AND OUTDOOR THERMOSTATS

Heat pump compressor operation at outdoor temperatures below 0 degrees F are neither desirable nor advantageous in terms of efficiency. Since most equipment at time of manufacture is not designated for any specific destination of the country, and most of the equipment is installed in areas not approaching the lower outdoor temperature range, the compressor cut-offs are not factory installed.

Outdoor thermostats are available to hold off various banks of electric heat until needed as determined by outdoor temperature. The set point of either type of thermostat is variable with geographic region and sizing of the heating equipment to the structure. Utilization of the Heating Application Data and the heat loss calculation of the building are useful in determining the correct set points.

COMPRESSOR CUT-OFF AND OUTDOOR THERMOSTAT WIRING

See specific wiring information on page 11.

HEAT ANTICIPATION

Both of the thermostats shown below have a fixed heat anticipator for stage 1 with no adjustment required. Stage 2 has an adjustable anticipator for the W2 connection and fixed for the W3 connection. Both the W2 and W3 circuits are controlled by the stage 2 bulb. The only heat anticipator that needs to be checked is stage 2 and it should be set to match the load carried by the W2 circuit. The normal factory wiring provides for only one electric heat contactor to be controlled by W2, and the anticipator should be set at .40A. If special field wiring is done, it is best to actually measure the load but a good rule is .40A for EACH heat contactor controlled by W2.

TABLE 2

WALL THERMOSTAT AND SUBBASE COMBINATIONS			
Group	Thermostat	Subbase	Predominant Features
A	8403-017 (T874R1129)	8404-009 (O674L1181)	Heat or Cool ① No Auto
B	8403-018 (T874R1024)	8404-010 (O674F1261)	Automatic Heat-Cool ② Changeover Position

- ① No automatic changeover position--must manually place in heat or cool. Reversing valve remains energized at all times system switch is in heat position (except during defrost cycle). No pressure equalization noise when thermostat is satisfied on either heating or cooling.
- ② Allows thermostat to control both heating and cooling operation when set in "Auto" position. Reversing valve de-energizes at end of each "On" heating cycle.

IMPORTANT NOTE: Both thermostat and subbase combinations shown above incorporate the following features: Man-Auto fan switch, Off-Heat-Cool-Em. Heat Switch, and two (2) indicator lamps--one for emergency heat and one for compressor malfunction.

THERMOSTAT INDICATOR LAMPS

The red lamp marked "Em.Ht." comes on and stays on whenever the system switch is placed in the emergency heat position. The green lamp marked "check" will come on if there is any problem that prevents the compressor from running when it is supposed to be.

EMERGENCY HEAT POSITION

The operator of the equipment must manually place the system switch in this position. This is done when there is a known problem with the indoor section, or when the green "check" lamp comes on indicating a problem.

DEFROST CYCLE

The defrost cycle is controlled by time and temperature. The 24 volt timer motor runs all the time the compressor is in operation. When the outdoor temperature is in the lower 40 degree F temperature range or colder, the outdoor coil temperature is 32 degree F or below. This temperature is sensed by the defrost thermostat mounted near the bottom of the outdoor coil on a return bend. The defrost thermostat closes at approximately 32 degree F. Every 60 (or 30) minutes that the compressor is running, contacts 3 - 5 close for 7 minutes. If the defrost thermostat is closed, the defrost relay energizes and places the system in defrost mode. An interlocking circuit is created with timer contacts 3 - 5 and defrost relay contacts 7 - 9 in series.

During the defrost mode, the refrigerant cycle switches back to the cooling cycle, the outdoor motor stops, electric heaters are energized, and hot gas passing through the outdoor coil melts any accumulated frost. When the temperature rises to approximately 57 degree F, the defrost thermostat opens, de-energizing the defrost relay and returning the system to heating operation.

If some abnormal or temporary condition such as a high wind causes the heat pump to have a prolonged defrost cycle, contacts 3 - 5 of the defrost timer will open after 7 minutes and restore the system to heating operations automatically.

There are two time settings on the defrost timer--30 minutes and 60 minutes. Most models are shipped wired on the 60 minute setting for greatest operating economy. If special circumstances require a change to the shorter time, remove wire connected to terminal 5/60 and reconnect to terminal 5/30.

There is a manual advance knob located on the timer. This can be used to advance timer to contact closure point if it is desired to check out defrost cycle operation, without waiting for time to elapse.

FIGURE 3
DEFROST TIMER WIRING

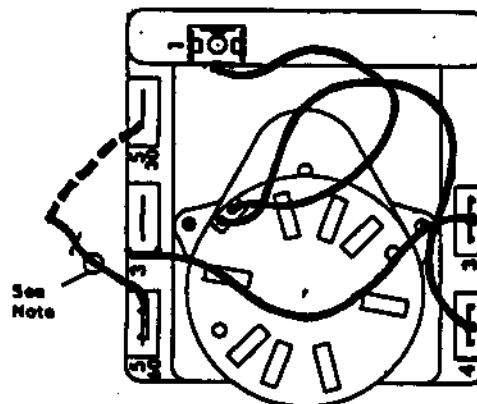

NOTE: All models are connected to 5/60 terminal (60 minutes). Any model can be changed from 60 minutes to 30 minutes by unplugging from 5/60 terminal and reconnecting to 5/30 terminal as shown by dotted line.

SERVICE HINTS

1. Caution homeowner to maintain clean air filters at all times. Also, not to needlessly close off supply and return air registers. This reduces air flow through the system, which shortens equipment service life as well as increasing operating costs.
2. Switching to heating cycle at 75 degree F or higher outside temperature may cause a nuisance trip of the manual reset high pressure switch.
3. The heat pump wall thermostats perform multiple functions. Be sure that all function switches are correctly set for the desired operating mode before trying to diagnose any reported service problems.

4. Check all power fuses or circuit breakers to be sure they are the correct rating.
5. Periodic cleaning of the outdoor coil to permit full and unrestricted airflow circulation is essential.

IMPORTANT INSTALLER NOTE

For improved start-up performance, wash the indoor coil with a dishwasher detergent.

CRANKCASE HEATERS

All units are provided with some form of compressor crankcase heat. Some single phase units utilize the compressor motor start winding in series with a portion of the run capacitor to generate heat within the compressor shell to prevent liquid refrigerant migration.

Some three phase units utilize a wraparound type of crankcase heater that warms the compressor oil from the outside.

Some single and three phase models have an insertion well-type heater located in the lower section of the compressor housing. This is a self-regulating type heater that draws only enough power to maintain the compressor at a safe temperature.

Some form of crankcase heat is essential to prevent liquid refrigerant from migrating to the compressor, causing oil pump out on compressor start-up and possible valve failure due to compressing a liquid.

Refer to unit wiring diagram to find exact type of crankcase heater used.

The decal in Figure 4 is affixed to all outdoor units detailing start-up procedure. This is very important. Please read carefully.

FIGURE 4

IMPORTANT

THESE PROCEDURES MUST BE FOLLOWED AT INITIAL START-UP AND AT ANY TIME POWER HAS BEEN REMOVED FOR 12 HOURS OR LONGER.

TO PREVENT COMPRESSOR DAMAGE WHICH MAY RESULT FROM THE PRESENCE OF LIQUID REFRIGERANT IN THE COMPRESSOR CRANKCASE

1. MAKE CERTAIN THE ROOM THERMOSTAT IS IN THE "OFF" POSITION. (THE COMPRESSOR IS NOT TO OPERATE).
2. APPLY POWER BY CLOSING THE SYSTEM DISCONNECT SWITCH. THIS ENERGIZES THE COMPRESSOR HEATER WHICH EVAPORATES THE LIQUID REFRIGERANT IN THE CRANKCASE.
3. ALLOW 4 HOURS OR 60 MINUTES PER POUND OF REFRIGERANT IN THE SYSTEM AS NOTED ON THE UNIT RATING PLATE, WHICHEVER IS GREATER.
4. AFTER PROPERLY ELAPSED TIME THE THERMOSTAT MAY BE SET TO OPERATE THE COMPRESSOR.
5. EXCEPT AS REQUIRED FOR SAFETY WHILE SERVICING — DO NOT OPEN SYSTEM DISCONNECT SWITCH.

7961-061

FIGURE 5

UNIT MODELS

20WA
24WA
18WH
24WH

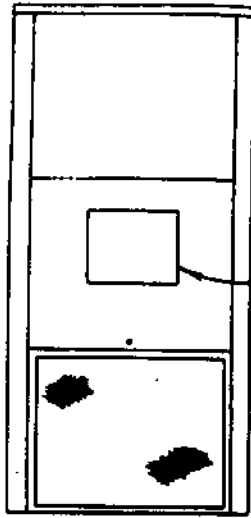

Model FAD10
Fresh Air Cover
With Adjustable
Damper

UNIT MODELS

30WA
36WA
30WH
36WH
42WA
49WA
48WH
45WH
60WH
60WA

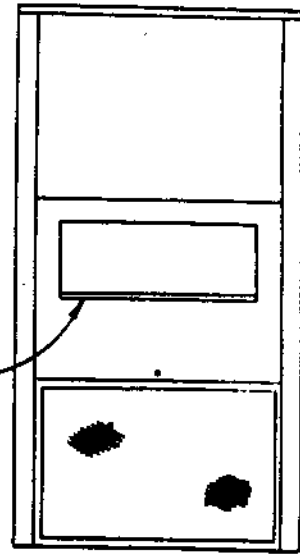

MODEL FAD25
Fresh Air Cover
With Adjustable
Damper

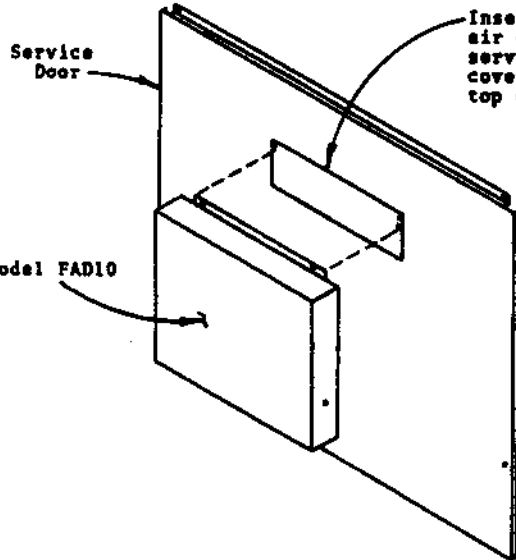

Service
Door

Model FAD10

Insert top flange of fresh
air cover into opening in
service door and push top of
cover assembly all the way to
top of opening.

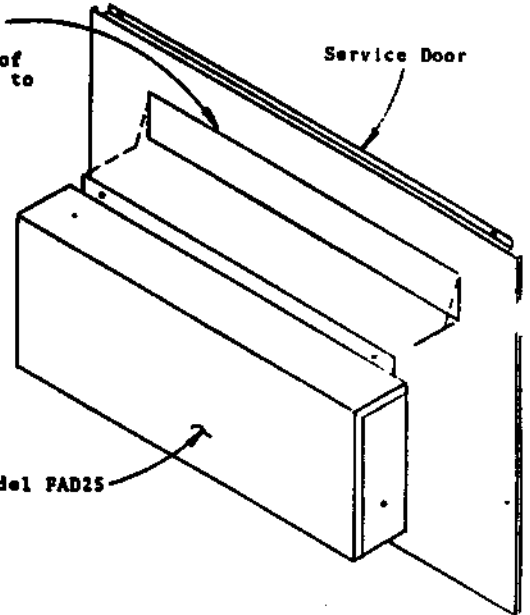

Service Door

Model FAD25

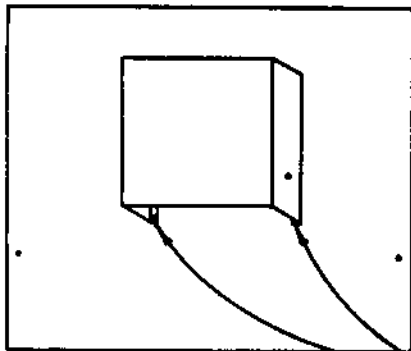

Secure bottom of
Fresh Air Cover Assembly
with two screws.

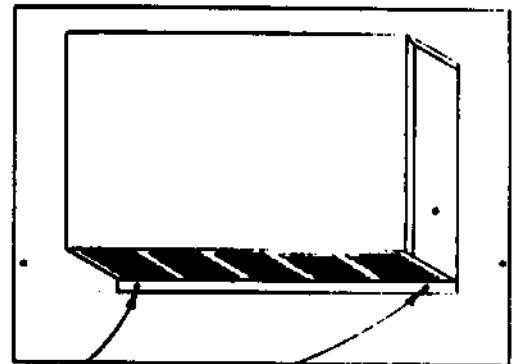

RIGHT SIDE VIEW

FIGURE 6

WALL VIEW

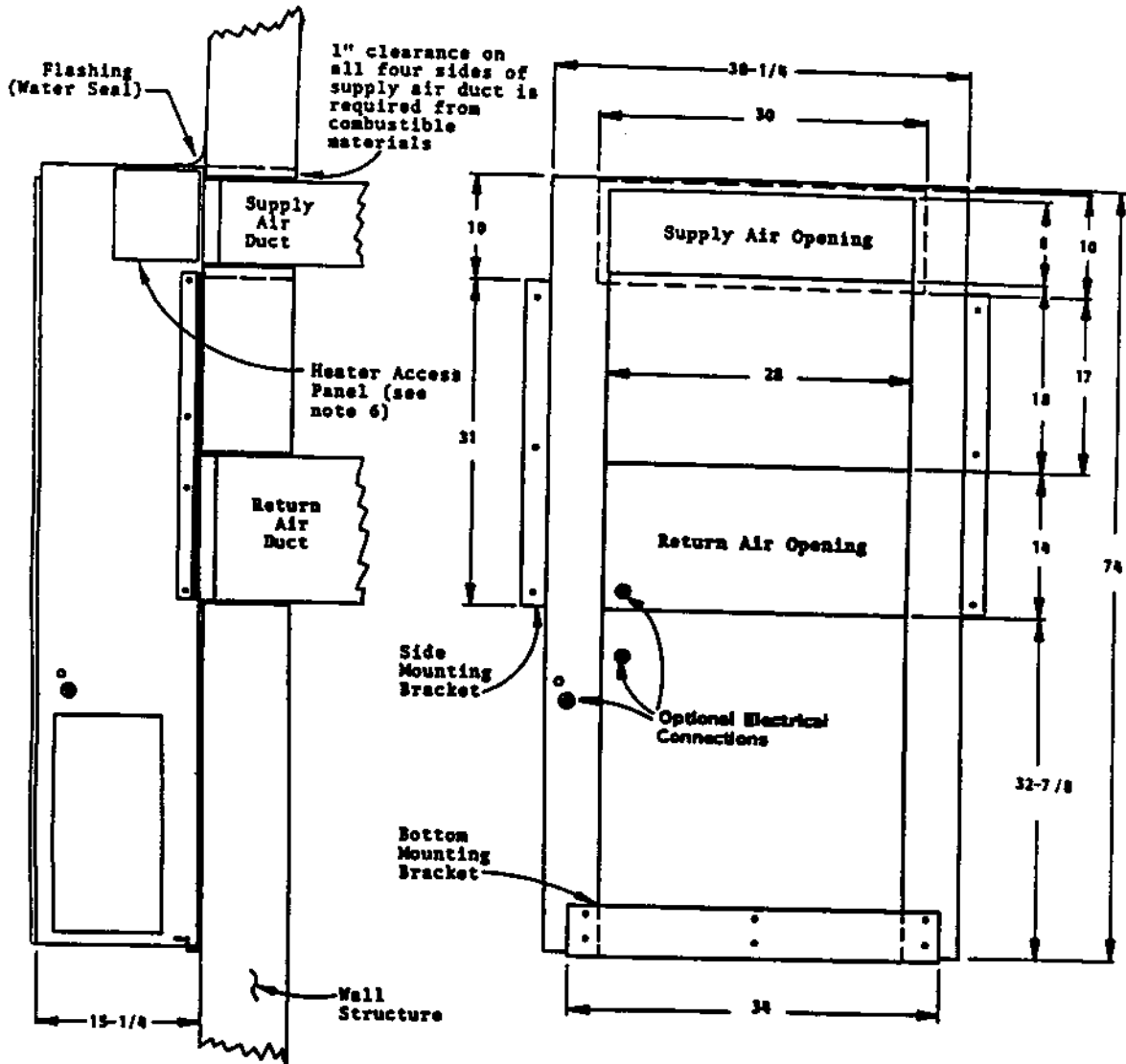

MOUNTING INSTRUCTIONS

1. These units are secured by wall mounting brackets which secure the unit to the outside wall surface at both sides and at the bottom.
2. The unit itself is suitable for "0" inch clearance, but the supply air duct flange and the first three feet of supply air duct require 1 inch clearance to combustible material. If combustible wall, use 30" x 10" dimensions for sizing, if non-combustible, use 28" x 8" dimensions.
3. After the wall opening positions have been selected, lay out the position for the bottom and side brackets. Fasten the brackets securely to the wall (type of fasteners will depend on wall construction).
4. Be sure to observe the 10" dimension when attaching the side brackets. This will assure that no screws are driven into the unit sides damaging any internal parts. One-half inch sheet metal screws are recommended.
5. For additional mounting rigidity, the return air and supply air (depending upon wall construction) frames or collars can be drilled and screwed or welded to the structural wall itself. Be sure to observe required clearance if combustible wall.
6. Maintain 30 inches minimum clearance on right side of unit to allow access to heat strip and control panel.

WARNING: Failure to provide the one inch clearance for the first three feet between the supply duct and a combustible surface can result in fire.

FAN BLADE SETTING DIMENSIONS

Shown in the drawing below are the correct fan blade setting dimensions for proper air delivery across the outdoor coil.

Any service work requiring removal or adjustment in the fan and/or motor area will require that the dimensions below be checked and blade adjusted in or out on the motor shaft accordingly.

FIGURE 7

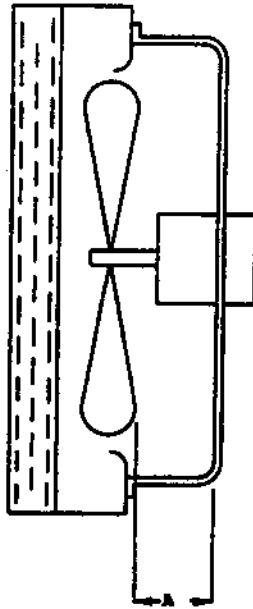

Model	Dimension A
30MB6	1
36MB7	1-1/4

REFRIGERANT CHARGE

The correct system R-22 charge is shown on the unit rating plate. Optimum unit performance will occur with a refrigerant charge resulting in a suction line temperature (6" from compressor) as shown in the following table:

TABLE 3

Model	Rated Airflow	° 95 F OD Temperature	° 82 F OD Temperature
30MB6	1000	54 - 56	63 - 65
36MB7	1100	47 - 49	60 - 62

The above suction line temperatures are based upon 80 degrees F dry bulb/67 degrees F wet bulb (50% R.H.) temperature and rated airflow across the evaporator during cooling cycle.

TABLE 4

INDOOR BLOWER PERFORMANCE CFM--DRY COIL WITH FILTER		
E.S.P. In H ₂ O	Models 30WB6-36WB7	
	Low	High
.0	970	1435
.1	925	1350
.2	900	1260
.3	--	1150
.4	--	1050
.5	--	940

TABLE 5

RATED CFM AND E.S.P. (WET COIL--COOLING)			
Model	Rated *CFM	Rated *E.S.P.	Recommended Airflow Range
30WB6	1000	.32	900 - 1100
36WB7	1100	.15	900 - 1210

*Rated CFM and E.S.P. on high speed tap.

COMPRESSOR CUT-OFF AND OUTDOOR THERMOSTAT WIRING

FIGURE 7
5 & 10KW 1-ph --- 6 & 9KW 3-ph

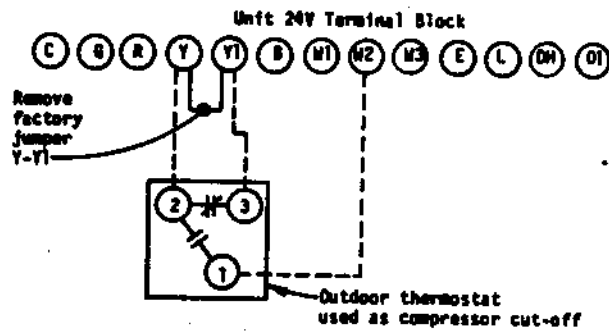

FIGURE 8
15KW 1-ph & 3-ph

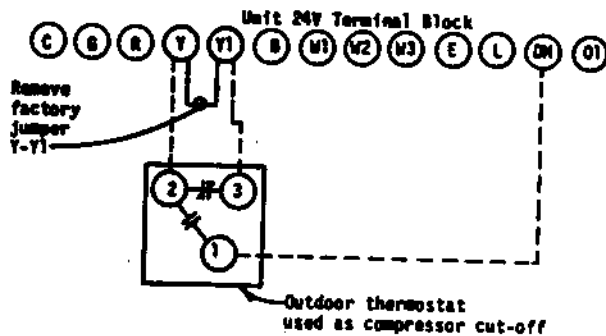

TABLE 6

COOLING

Air Temperature Entering Outdoor Coil Degree F

Model	Return Air Temperature	Pressure	75	80	85	90	95	100	105	110	115
			°	°	°	°	°	°	°	°	°
30MB6	75 deg. DB	Low Side	72	74	75	76	77	79	79	80	82
	62 deg. WB	High Side	246	258	271	284	296	309	322	335	348
	80 deg. DB	Low Side	77	79	80	81	82	84	85	86	88
	67 deg. WB	High Side	252	265	278	291	304	317	330	344	357
	85 deg. DB	Low Side	83	85	86	87	88	90	91	92	95
	72 deg. WB	High Side	261	274	288	301	315	328	342	356	369
36MB7	75 deg. DB	Low Side	64	65	67	69	71	73	75	77	79
	62 deg. WB	High Side	215	231	247	261	277	292	307	323	338
	80 deg. DB	Low Side	68	70	72	74	76	78	80	82	84
	67 deg. WB	High Side	221	237	253	268	284	299	315	331	347
	85 deg. DB	Low Side	73	75	77	80	82	84	86	88	90
	72 deg. WB	High Side	229	245	262	277	294	309	326	343	359

TABLE 7

HEATING

Air Temperature Entering Outdoor Coil Degree F

Model	Return Air Temperature	Pressure	0	5	10	15	17	20	25	30	35	40	45	47	50	55	60
			°	°	°	°	°	°	°	°	°	°	°	°	°	°	°
30MB6	70 degree	Low Side	18	22	26	30	32	34	38	42	46	50	54	56	58	62	66
		High Side	156	165	173	182	185	190	199	207	217	225	234	236	242	251	260
36MB7	70 degree	Low Side	17	20	25	28	30	33	36	40	45	48	53	54	56	60	65
		High Side	142	155	167	179	184	191	204	216	226	240	253	259	266	278	290

Low side pressure ± 2 PSIG

High side pressure ± 5 PSIG

Tables are based upon rated CFM (airflow) across the evaporator coil and should be found under section titled "Refrigerant Charge" elsewhere in manual. If there is any doubt as to correct operating charge being in the system, the charge should be removed, system evacuated, and recharged to serial plate instructions.

BLOWER ASSEMBLY

Date: 05/04/89

Dwg. No.	Part No.	Description	9	0
			0	0
			0	0
			1	1
			0	0
			3	7
			9	0
1	5152-051	Housing, Wheel and Cutoff (CW)	X	X
2	5152-052	Housing, Wheel and Cutoff	X	X
3	8105-029	Blower Motor (230/208)	X	
3	8105-033	Blower Motor (460)		X
4	8552-002	Capacitor	X	X
5	8200-031	Motor Mount	X	X
6	5451-011	Grommets	6	6
7	104-505	Back Brace	X	X
8	104-001	Side Angle	2	2
9	102-300	Front Brace	X	X

WZ21/PARTSLIST/TEXTLIB

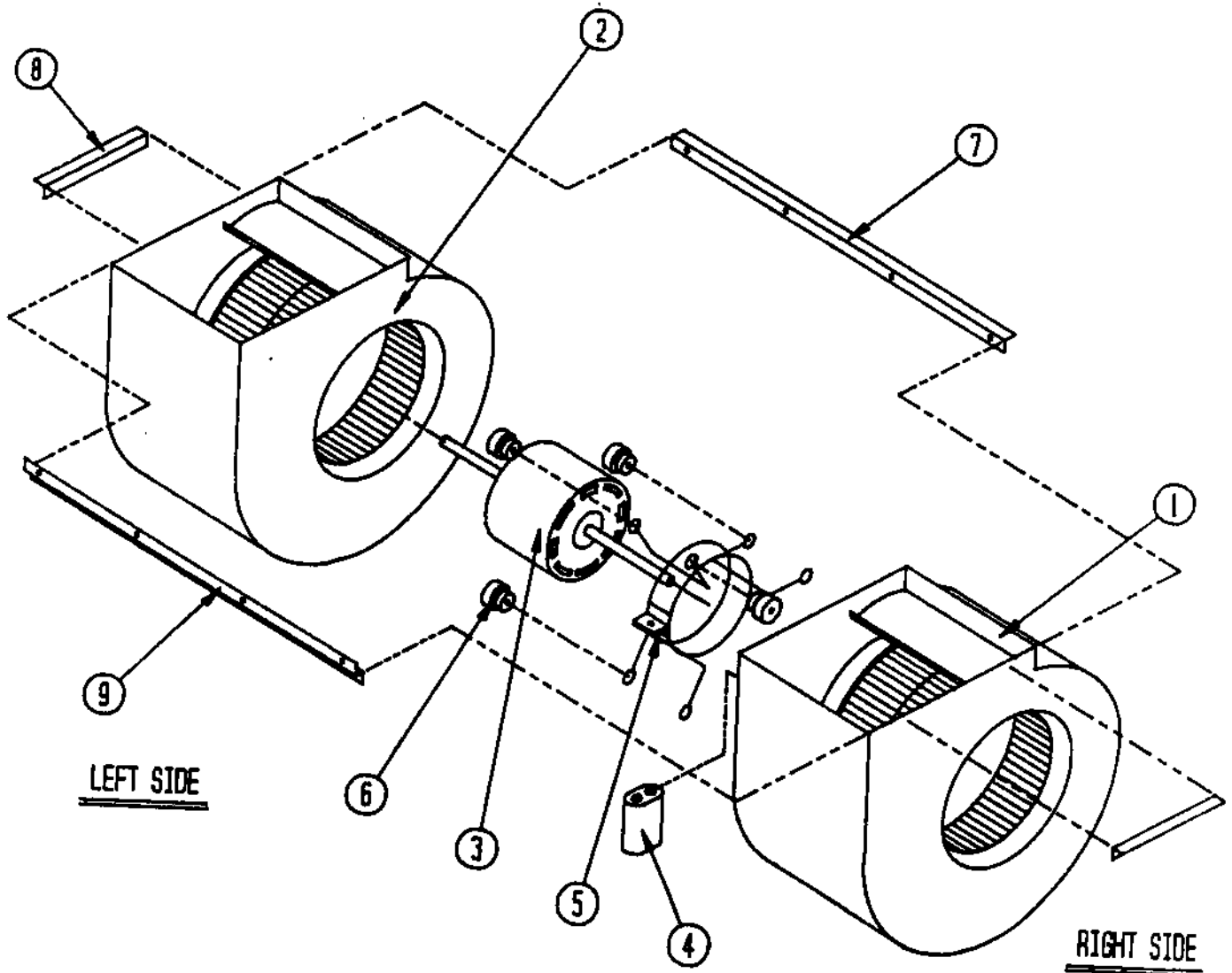

CABINET COMPONENTS
30WH6, 36WH7

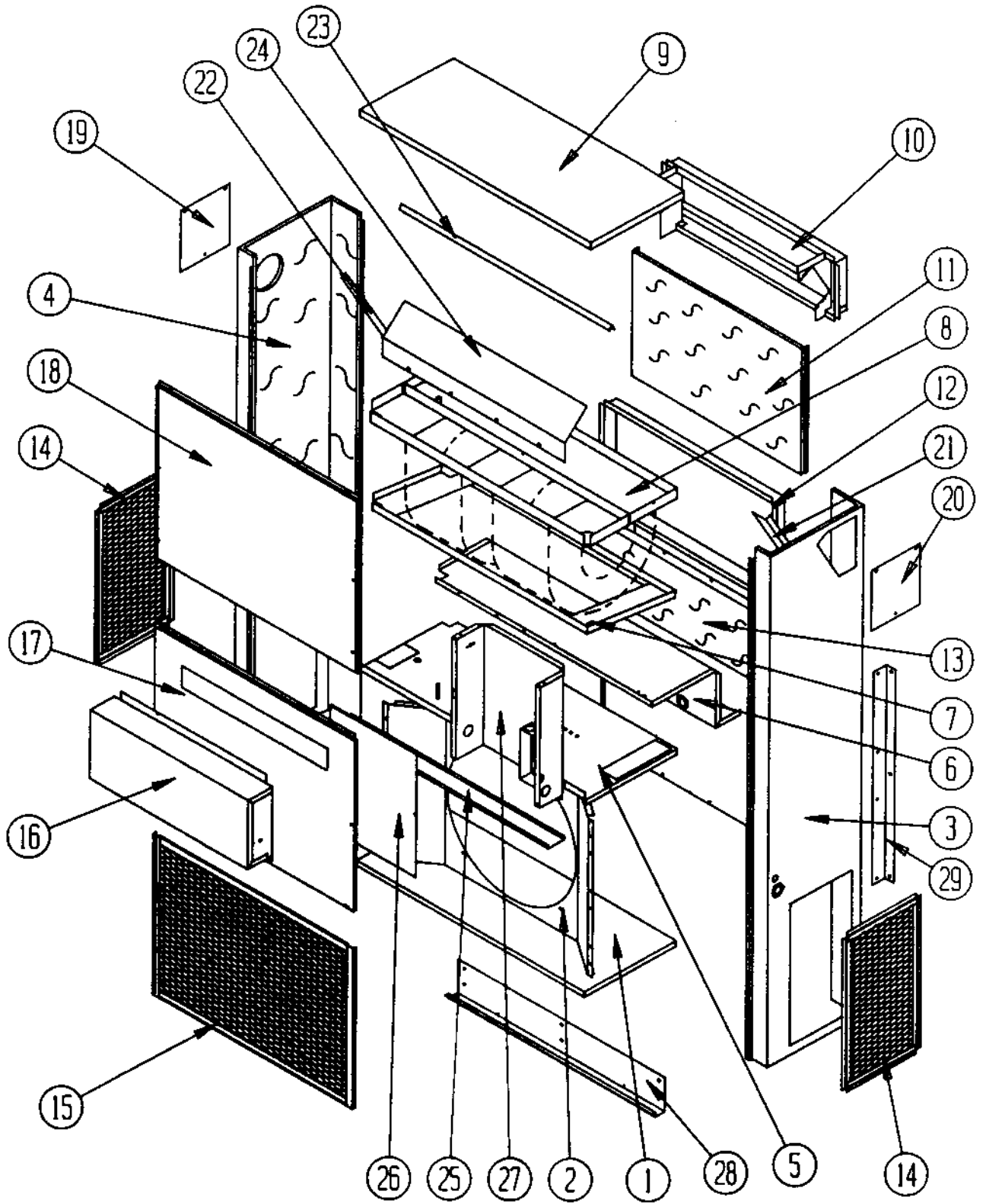

CABINET COMPONENTS
30WA6, 36WA6, 30WB6, 36WB7

Date: 05/04/89

Item	Part No.	Description	U S A G E
1	126-003	Lower Base	X
2	124-002	Fan Shroud	X
3	501-164	Right Side	X
4	501-165	Left Side	X
5	127-098	Compressor Base	X
6	520-097	Compressor Partition	X
7	131-002	Filter Tray	X
8	521-004	Blower Addition/Drain Pan Assembly	X
9	506-095	Top	X
10	111-017	Outlet Airframe Assembly	X
11	508-056	Upper Back	X
12	111-018	Inlet Air Frame Assembly	X
13	508-057	Lower Back	X
14	119-004	Side Grille	2
15	119-003	Condenser Grille	X
16	FAD25	Fresh Air Damper Assembly	X
17	552-107	Service Door	X
18	514-046	Upper Front	X
19	5427004	Left Side Cover Plate	X
20	5428004	Right Side Cover Plate	X
21	141-006	Right Evaporator Support	X
22	141-007	Left Evaporator Support	X
23	136-093	Evaporator Fill Plate	X
24	134-008	Air Baffle	X
25	136-002	Condenser Coil Spacer	X
26	Cntrl.Cvr.	See Control Panel Assembly Drawing and Parts List	X
27	Cntrl.Pnl. Assembly	See Control Panel Assembly Drawing and Parts List	X
28	112-006	Bottom Mounting Bracket	X
29	112-002	Side Mounting Bracket	2

WE28/PARTSLIST/TEXTLIB

FUNCTIONAL COMPONENTS
30WH6

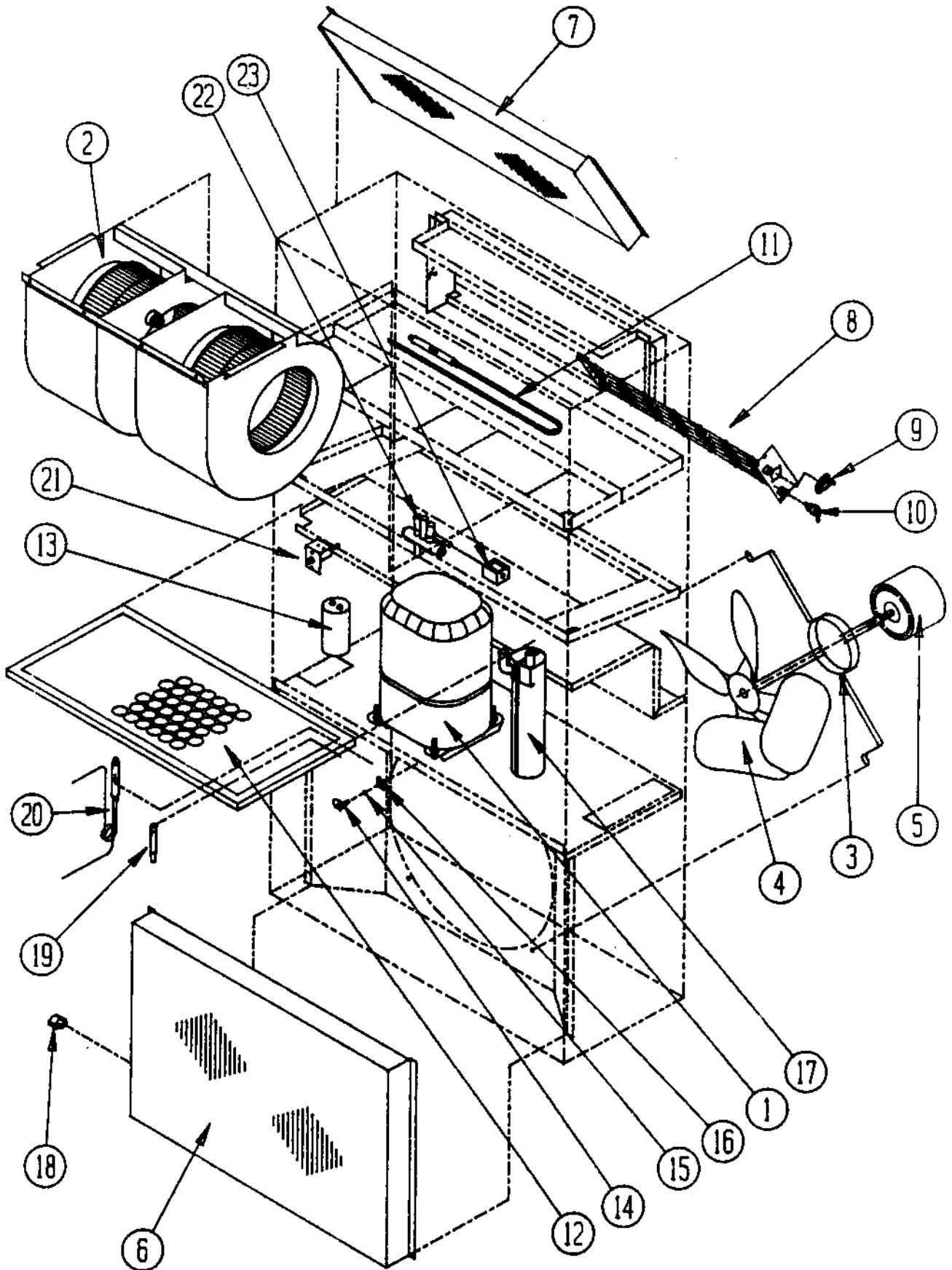

FUNCTIONAL COMPONENTS
30WB6

Date: 05/04/89

Dwg. No.	Part No.	Description	30WB6 A O O M, C	30WB6 A O 5 M, C	30WB6 A 1 O M, C	30WB6 B 1 5 M, C	30WB6 B O O M, C	30WB6 B O 9 M, C
1	8000-099	Compressor H23B283ABCA	X	X	X	X		
1	8000-053	Compressor CRG3-0250-TP5					X	X
2	900-039	Blower Assembly (Complete)	X	X	X	X	X	X
3	8200-001	Motor Mount (Condenser)	X	X	X	X	X	X
4	5151-032	Fan Blade	X	X	X	X	X	X
5	8103-016	Condenser Motor	X	X	X	X	X	X
6	5051-052	Condenser Coil	X	X	X	X	X	X
7	5060-052	Evaporator Coil	X	X	X	X	X	X
8	8604-089	Heat Strip		X				
8	8604-091	Heat Strip			X			
8	8604-047	Heat Strip				X		
8	8604-048	Heat Strip						X
9	8402-031	Limit Control		X	X	X		X
10	8402-032	Thermal Cutoff		X	2	3		2
11	800-0121	Cooling Capillary Assembly	X	X	X	X	X	X
12	7004-008	Air Filter	X	X	X	X	X	X
13	8552-032	Capacitor (Compressor)	X	X	X	X		
14	1171-019	1/4 Turn Fastener	X	X	X	X	X	X
15	1171-021	Fastener Retainer	X	X	X	X	X	X
16	1171-020	Fastener Retainer	X	X	X	X	X	X
17	5202-016	Accumulator	X	X	X	X	X	X
18	8408-016	Defrost Thermostat	X	X	X	X	X	X
19	5651-036	Check Valve	X	X	X	X	X	X
20	800-0122	Heating Capillary Assembly	X	X	X	X	X	X
21	8406-010	High Pressure Switch	X	X	X	X	X	X
22	5650-013	Reversing Valve	X	X	X	X	X	X
23	5650-008	Solenoid Coil	X	X	X	X	X	X

WZ7/PARTSLIST/TEXTLIB

FUNCTIONAL COMPONENTS
36WH7

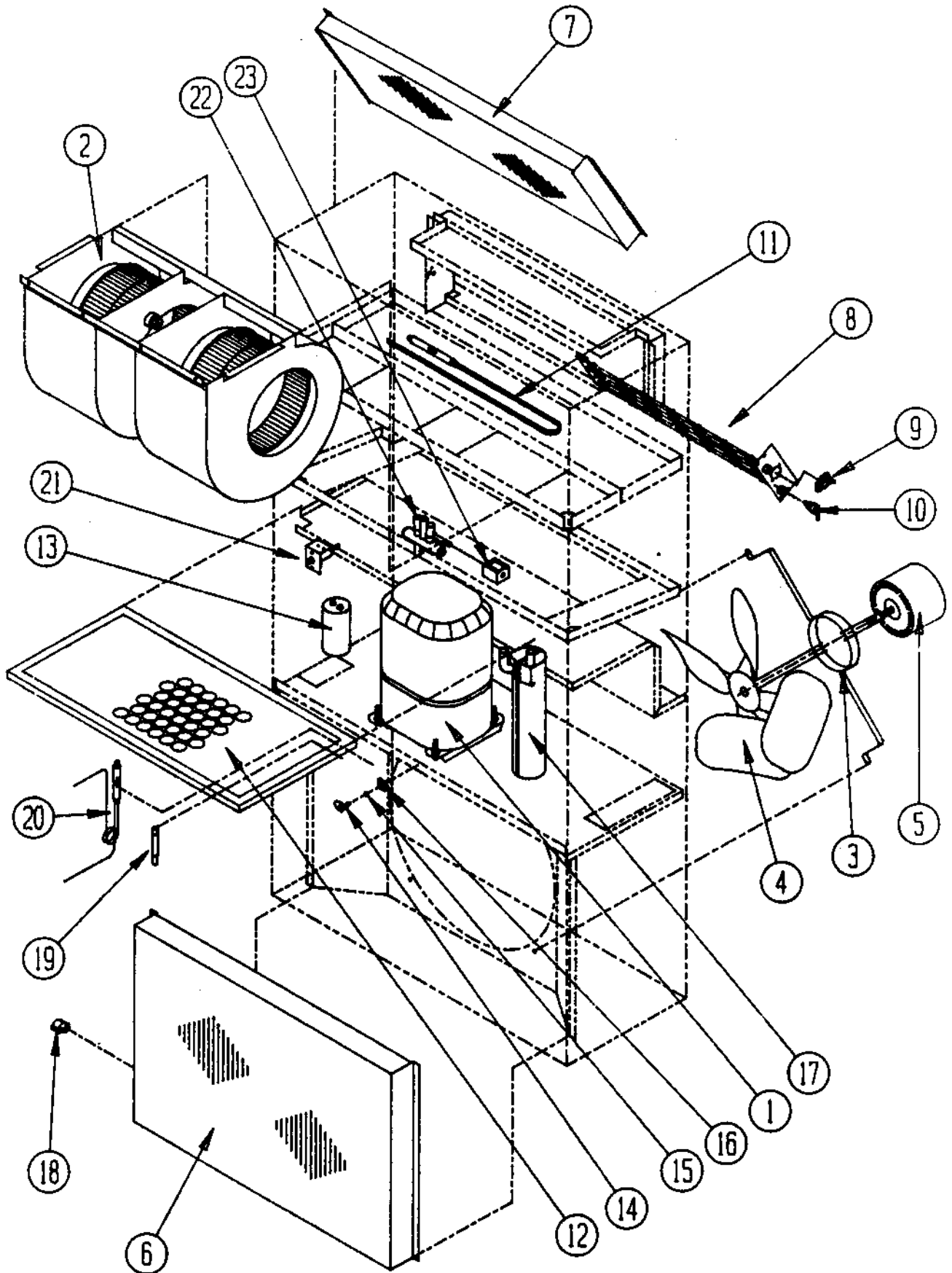

FUNCTIONAL COMPONENTS

36WB7

Date: 05/04/89

Dwg. No.	Part No.	Description	3 6 W H 7 A O O N, C	3 6 W H 7 A O 5 N, C	3 6 W H 7 A 1 0 N, C	3 6 W H 7 A 1 5 N, C	3 6 W H 7 B O O N, C	3 6 W H 7 B O 9 N, C	3 6 W H 7 B 1 0 N, C	3 6 W H 7 C O 9 N, C	3 6 W H 7 C 1 5 N, C
1	8000-058	Compressor CRJ3-0300-PFV	X	X	X	X					
1	8000-059	Compressor CRJ3-0300-TP5					X	X	X		
1	8000-060	Compressor CRJ3-0300-TPD								X	X
2	900-039	Blower Assembly (Complete)	X	X	X	X	X	X	X		X
2	900-070	Blower Assembly (Complete)								X	X
3	8200-001	Motor Mount (Condenser)	X	X	X	X	X	X	X	X	X
4	5151-032	Fan Blade	X	X	X	X	X	X	X	X	X
5	8103-019	Condenser Motor	X	X	X	X	X	X	X		
5	8103-014	Condenser Motor								X	X
6	5051-053	Condenser Coil	X	X	X	X	X	X	X	X	X
7	5060-052	Evaporator Coil	X	X	X	X	X	X	X	X	X
8	8604-089	Heat Strip		X							
8	8604-091	Heat Strip			X						
8	8604-047	Heat Strip				X					
8	8604-048	Heat Strip					X	X			
8	8604-049	Heat Strip						X			
8	8604-072	Heat Strip							X	X	
8	8604-079	Heat Strip								X	
9	8402-031	Limit Control		X	X	X		X	X		
9	8402-060	Limit Control								X	X
10	8402-032	Thermal Cut-Off		X	2	3		2	4		
10	8402-059	Thermal Cut-Off								2	4
11	800-0118	Cooling Capillary Assembly	X	X	X	X	X	X	X	X	X
12	7004-008	Air Filter	X	X	X	X	X	X	X	X	X
13	8652-028	Capacitor (Compressor)	X	X	X	X					
14	1171-019	1/4 Turn Fastener	X	X	X	X	X	X	X	X	X
15	1171-021	Fastener Retainer	X	X	X	X	X	X	X	X	X
16	1171-020	Fastener Receptacle	X	X	X	X	X	X	X	X	X
17	5202-016	Accumulator	X	X	X	X	X	X	X	X	X
18	8408-016	Defrost Thermostat	X	X	X	X	X	X	X	X	X
19	5651-036	Check Valve	X	X	X	X	X	X	X	X	X
20	800-0144	Heating Capillary Assembly	X	X	X	X	X	X	X	X	X
21	8406-010	High Pressure Switch	X	X	X	X	X	X	X	X	X
22	5650-013	Reversing Valve	X	X	X	X	X	X	X	X	X
23	5650-008	Solenoid Coil	X	X	X	X	X	X	X	X	X

NZ26/PARTSLIST/TEXTLIB

CONTROL PANEL
30WH6
WITHOUT CIRCUIT BREAKERS

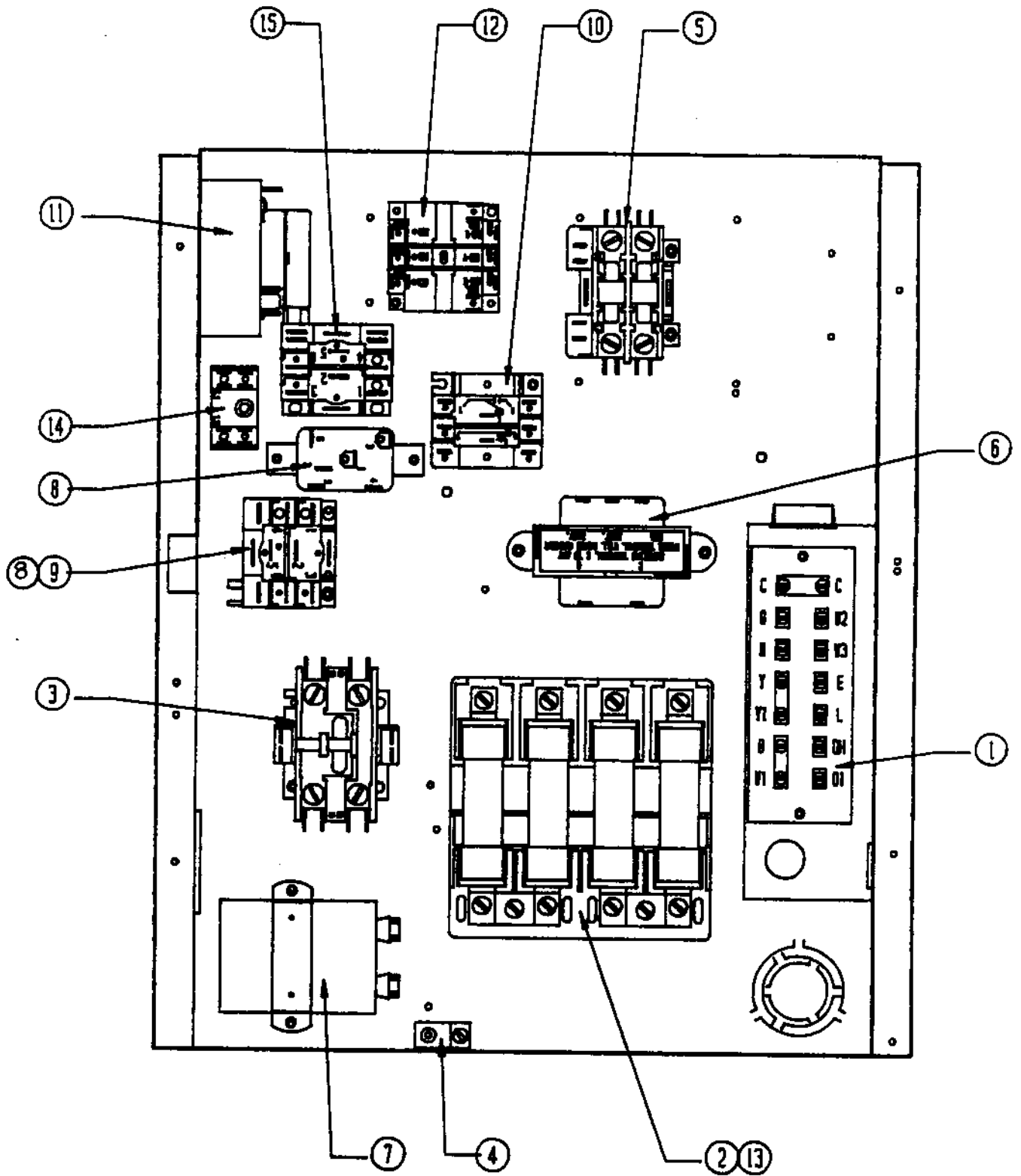

30-36 WH

CONTROL PANEL
30W6
WITHOUT CIRCUIT BREAKERS

Page:
Date: 05/04/89

Dwg. No.	Part No.	Description	3	3	3	3	3	3
			0	0	0	0	0	0
			W	W	W	W	W	W
			H	H	H	H	H	H
			6	6	6	6	6	6
			A	A	A	B	B	B
			O	O	1	1	O	O
			O	5	O	5	O	9
			N	N	N	N	N	N
1	8607-019	Low Voltage Terminal Strip	X	X	X	X	X	X
2	8607-013	Terminal Block	X	X				
2	8607-014	Terminal Block						X
2	8614-017	Fuse Block			X			
2	8614-018	Fuse Block				X		
3	8401-007	Compressor Contactor	X	X	X	X		
3	8401-002	Compressor Contactor					X	X
4	8611-006	Ground Terminal	X	X	X	X	X	X
5	8401-006	Heat Contactor		X	X	2		X
6	8407-035	Transformer	X	X	X	X	X	X
7	8552-002	Condenser Fan Capacitor	X	X	X	X	X	X
8	8201-009	Blower Relay	X	X	X	X	X	X
9	8201-024	Compressor Fault Relay	X	X	X	X		
10	8201-013	Emergency Heat Relay				X		
11	8612-012	Defrost Timer	X	X	X	X	X	X
12	8201-047	Defrost Relay	X	X	X	X	X	X
	4012-110	Wiring Diagram	X					
	4012-120	Wiring Diagram		X				
	4012-130	Wiring Diagram			X			
	4012-140	Wiring Diagram				X		
	4012-210	Wiring Diagram					X	
	4012-220	Wiring Diagram						X
	132-003	Control Panel Cover	X	X			X	X
	133-036	Control Panel Cover			X	X		

WE22/PARTSLIST/TEXTLIB

CONTROL PANEL
30WH6
WITH CIRCUIT BREAKERS

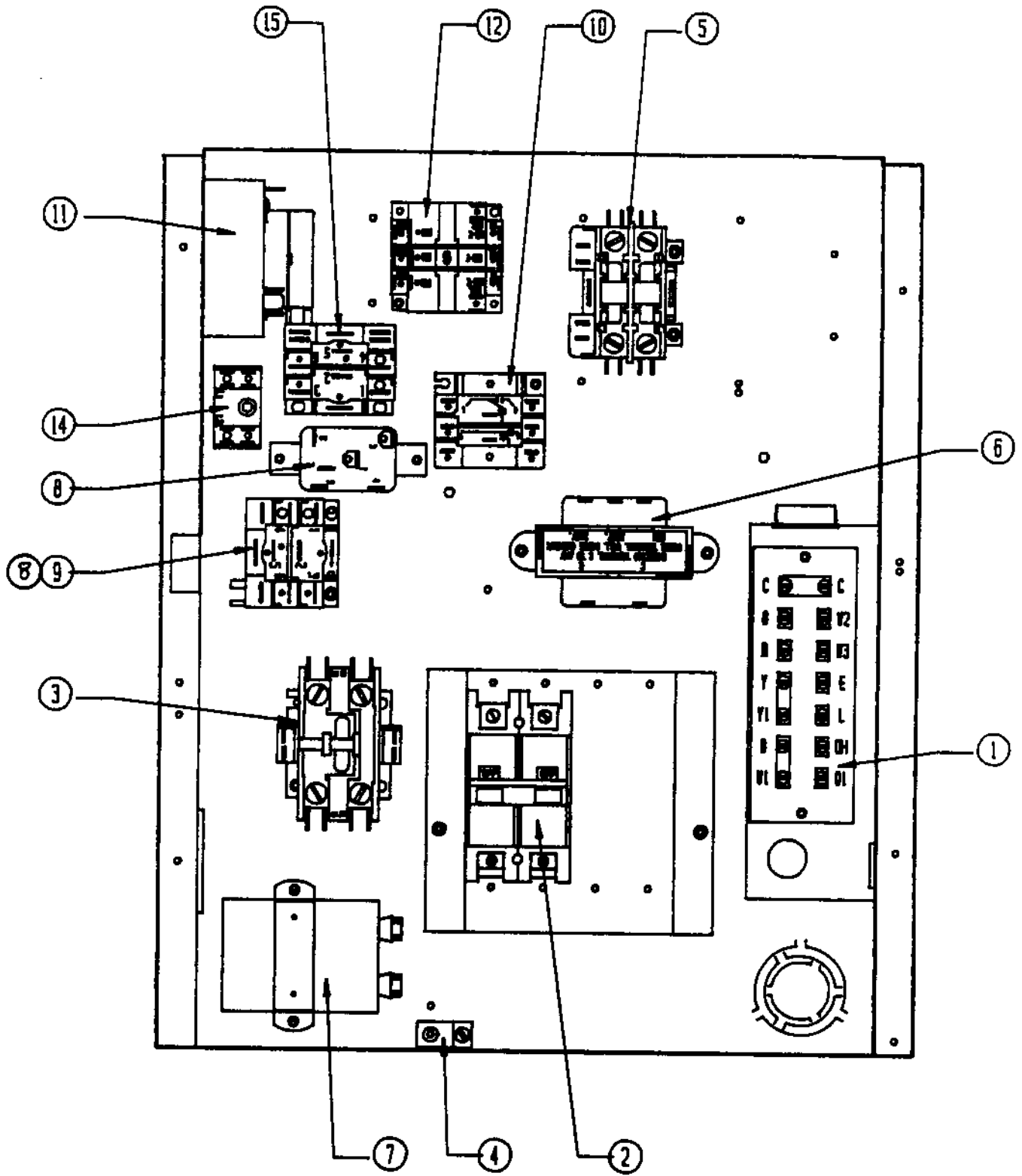

30-36 WH

CONTROL PANEL
30WB6
WITH CIRCUIT BREAKER

Date: 05/04/89

Qty. No.	Part No.	Description	3	3	3	3	3	3
			O W H 6 A O O C	O W H 6 A O 5 C	O W H 6 A 1 O C	O W H 6 A 1 5 C	O W H 6 B O O C	O W H 6 B O 9 C
1	8607-019	Low Voltage Terminal Strip	X	X	X	X	X	X
2	8615-009	Circuit Breaker	X					
2	8615-015	Circuit Breaker		X	X	X		
2	8615-013	Circuit Breaker			X			
2	8615-016	Circuit Breaker				X		
2	8615-017	Circuit Breaker					X	
2	8615-021	Circuit Breaker						X
3	8401-007	Compressor Contactor	X	X	X	X		
3	8401-002	Compressor Contactor					X	X
4	8611-006	Ground Terminal	X	X	2	2	X	X
5	8401-006	Heat Contactor		X	X	2		X
6	8407-035	Transformer	X	X	X	X	X	X
7	8552-002	Condenser Fan Capacitor	X	X	X	X	X	X
8	8201-009	Blower Relay	X	X	X	X	X	X
9	8201-024	Compressor Fault Relay	X	X	X	X		
10	8201-013	Emergency Heat Relay				X		
11	8612-012	Defrost Timer	X	X	X	X	X	X
12	8201-047	Defrost Relay	X	X	X	X	X	X
	4012-111	Wiring Diagram	X					
	4012-121	Wiring Diagram		X				
	4012-131	Wiring Diagram			X			
	4012-141	Wiring Diagram				X		
	4012-211	Wiring Diagram					X	
	4012-221	Wiring Diagram						X
	132-027	Control Panel Cover	X	X				
	132-029	Control Panel Cover			X	X		
	132-028	Control Panel Cover					X	X

WE23/PARTSLIST/TEXTLIB

CONTROL PANEL
36WH7
WITHOUT CIRCUIT BREAKERS

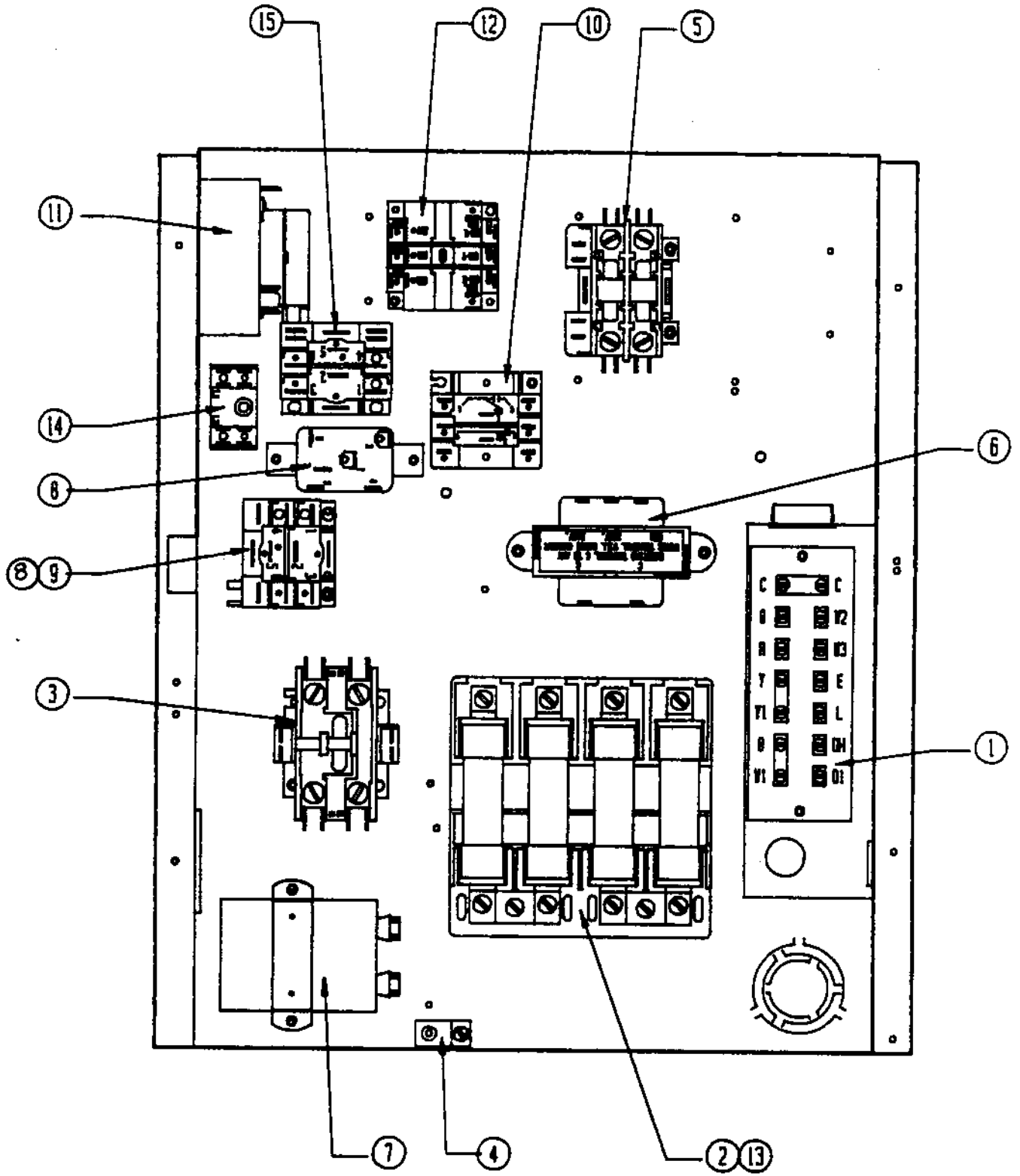

30-36 WH

CONTROL PANEL
36W87
WITHOUT CIRCUIT BREAKERS

Date: 05/04/89

Dwg. No.	Part No.	Description	3	3	3	3	3	3	3	3	3	3
			6	6	6	6	6	6	6	6	6	6
			W	W	W	W	W	W	W	W	W	W
			H	H	H	H	H	H	H	H	H	H
			7	7	7	7	7	7	7	7	7	7
			A	A	A	B	B	B	B	C	C	C
			0	0	1	1	0	0	1	0	0	1
			0	5	0	5	0	9	5	0	9	5
			N	N	N	N	N	N	N	N	N	N
1	8607-019	Low Voltage Terminal Strip	X	X	X	X	X	X	X	X	X	X
2	8607-013	Terminal Block	X	X								
2	8607-014	Terminal Block						X	X	X	X	X
2	8614-017	Fuse Block			X							
2	8614-018	Fuse Block				X						
3	8401-007	Compressor Contactor	X	X	X	X						
3	8401-002	Compressor Contactor					X	X	X	X	X	X
4	8611-006	Ground Terminal	X	X	X	X	X	X	X	X	X	X
5	8401-006	Heat Contactor		X	X	2		X	2			
5	8401-002	Heat Contactor									X	2
6	8407-035	Transformer	X	X	X	X	X	X	X			
6	8407-040	Transformer								X	X	X
7	8552-002	Condenser Fan Capacitor	X	X	X	X	X	X	X	X	X	X
8	8201-009	Blower Relay	X	X	X	X	X	X	X			
8	8201-032	Blower Relay								X	X	X
9	8201-024	Compressor Fault Relay	X	X	X	X						
10	8201-013	Emergency Heat Relay				X			X			X
11	8612-012	Defrost Timer	X	X	X	X	X	X	X	X	X	X
12	8201-047	Defrost Relay	X	X	X	X	X	X	X	X	X	X
12	8201-032	Defrost Relay								X	X	X
13	8607-015	Phenolic Insulator								X	X	X
14	8607-017	Motor Speed Terminal Block								X	X	X
	4013-110	Wiring Diagram	X									
	4013-120	Wiring Diagram		X								
	4013-130	Wiring Diagram			X							
	4013-140	Wiring Diagram				X						
	4013-210	Wiring Diagram					X					
	4013-220	Wiring Diagram						X				
	4013-230	Wiring Diagram							X			
	4013-310	Wiring Diagram								X		
	4013-320	Wiring Diagram									X	
	4013-230	Wiring Diagram										X
	132-003	Control Panel Cover	X	X			X	X	X	X	X	X
	133-036	Control Panel Cover			X	X						

WE25/PARTSLIST/TEXTLIB

CONTROL PANEL
36WH7
WITH CIRCUIT BREAKERS

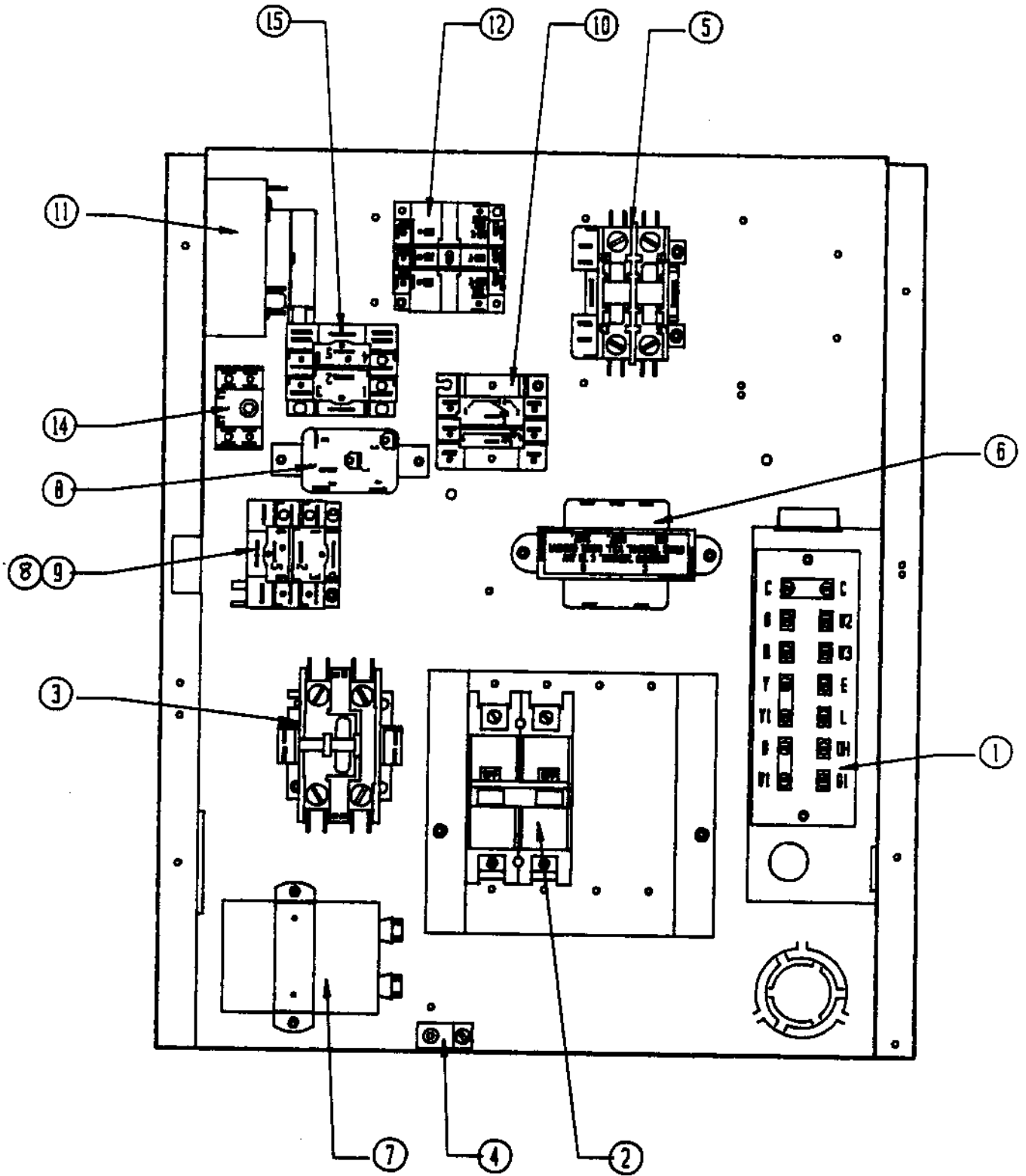

30-36 WH

CONTROL PANEL
36WH7
WITH CIRCUIT BREAKER

Date: 05/04/89

Qty. No.	Part No.	Description	3	3	3	3	3	3	3	3	3	3
			6	6	6	6	6	6	6	6	6	6
			W	W	W	W	W	W	W	W	W	W
			H	H	H	H	H	H	H	H	H	H
			7	7	7	7	7	7	7	7	7	7
			A	A	A	A	B	B	B	C	C	C
			O	O	1	1	O	O	1	O	O	1
			O	5	O	5	O	9	5	O	9	5
			C	C	C	C	C	C	C	C	C	C
1	8607-019	Low Voltage Terminal Strip	X	X	X	X	X	X	X	X	X	X
2	8615-015	Circuit Breaker	X									
2	8615-016	Circuit Breaker		X	X	2						
2	8615-013	Circuit Breaker			X							
2	8615-020	Circuit Breaker					X					
2	8615-011	Circuit Breaker						X	X			
2	8615-023	Circuit Breaker								X		
2	8615-026	Circuit Breaker									X	X
3	8401-007	Compressor Contactor	X	X	X	X						
3	8401-002	Compressor Contactor					X	X	X	X	X	X
4	8611-006	Ground Terminal	X	X	2	2	X	X	X	X	X	X
5	8401-006	Heat Contactor		X	X	2		X	2			
5	8401-002	Heat Contactor									X	2
6	8407-035	Transformer	X	X	X	X	X	X	X			
6	8407-040	Transformer								X	X	X
7	8552-002	Condenser Fan Capacitor	X	X	X	X	X	X	X	X	X	X
8	8201-009	Blower Relay	X	X	X	X	X	X	X			
8	8201-032	Blower Relay								X	X	X
9	8201-024	Compressor Fault Relay	X	X	X	X						
10	8201-013	Emergency Heat Relay				X			X			X
11	8612-012	Defrost Timer	X	X	X	X	X	X	X	X	X	X
12	8201-047	Defrost Relay	X	X	X	X	X	X	X	X	X	X
12	8201-032	Defrost Relay								X	X	X
14	8607-017	Motor Speed Terminal Block								X	X	X
	4013-111	Wiring Diagram	X									
	4013-121	Wiring Diagram		X								
	4013-131	Wiring Diagram			X							
	4013-141	Wiring Diagram				X						
	4013-211	Wiring Diagram					X					
	4013-221	Wiring Diagram						X				
	4013-231	Wiring Diagram							X			
	4013-311	Wiring Diagram								X		
	4013-321	Wiring Diagram									X	
	4013-331	Wiring Diagram										X
	132-027	Control Panel Cover	X	X								
	132-029	Control Panel Cover			X	X						
	132-028	Control Panel Cover					X	X	X			
	132-050	Control Panel Cover								X	X	X

WE24/PARTSLIST/TEXTLIB

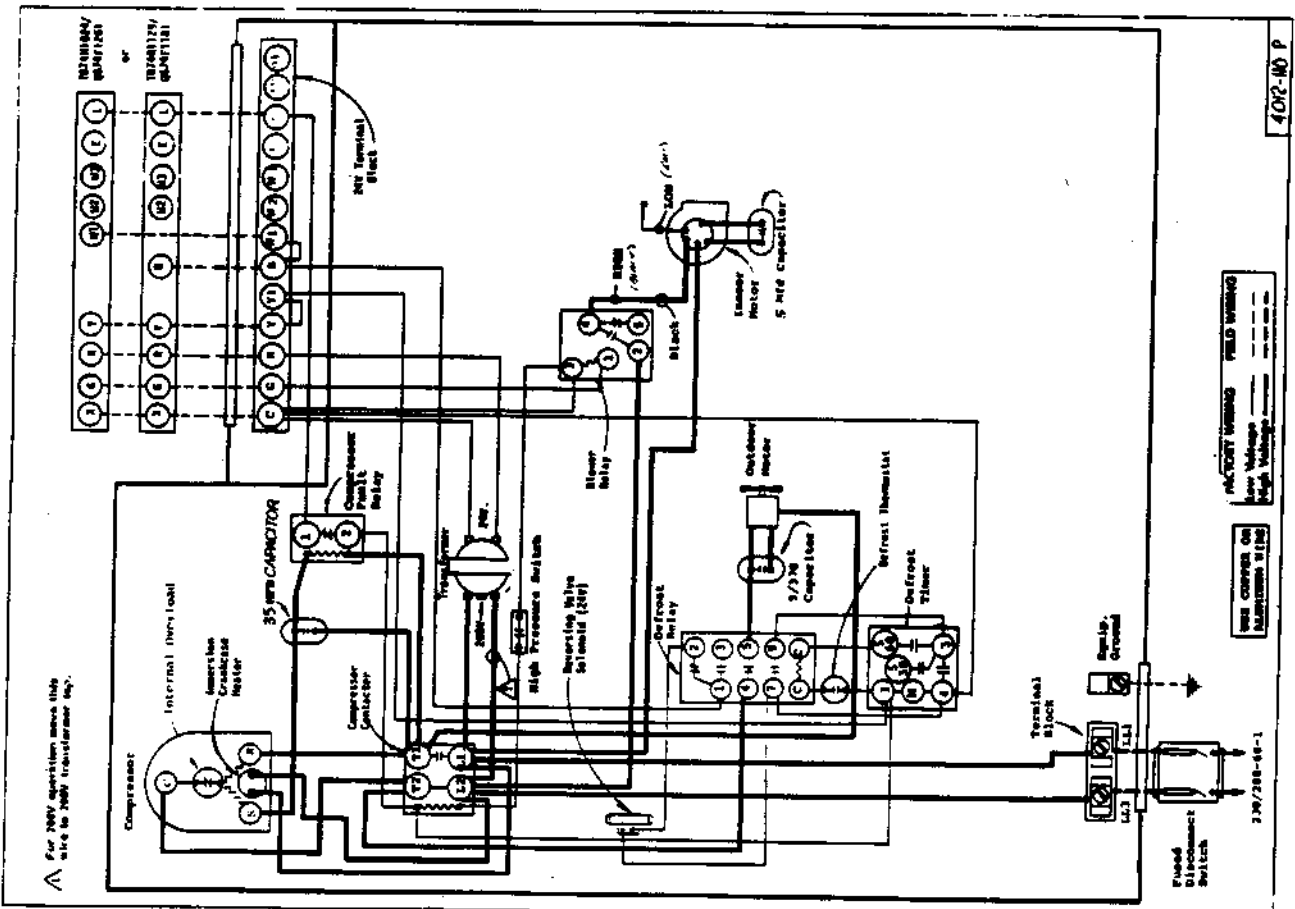
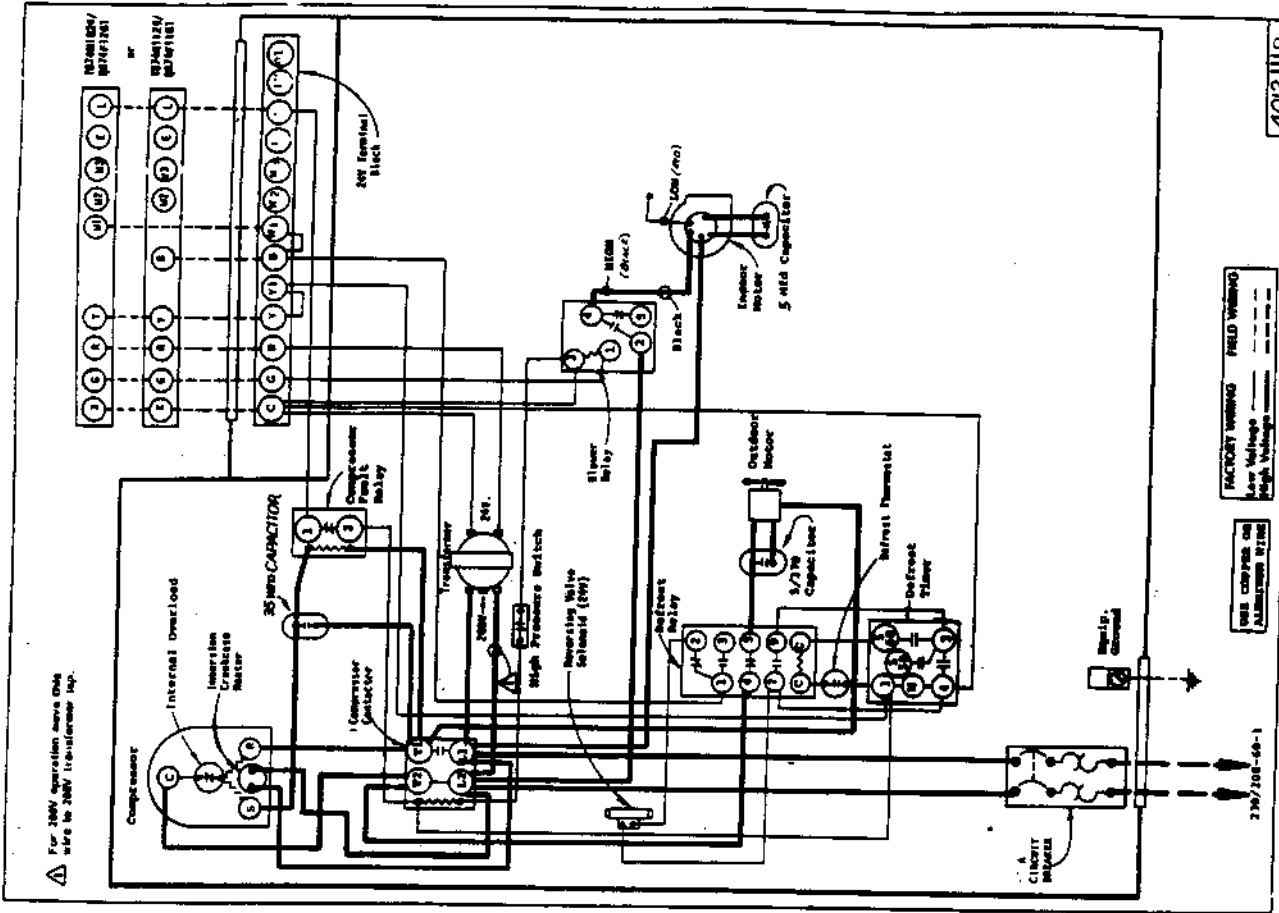

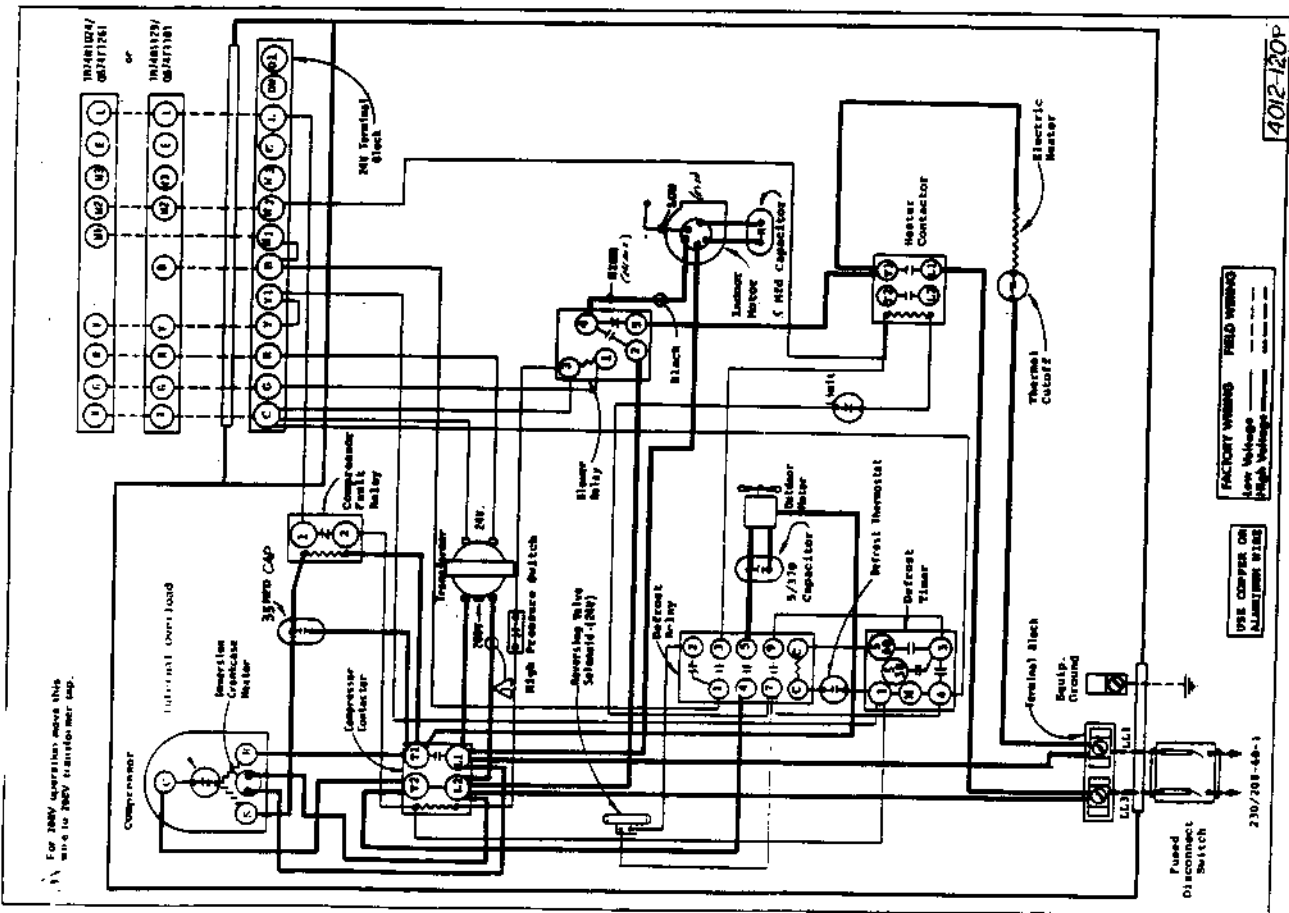
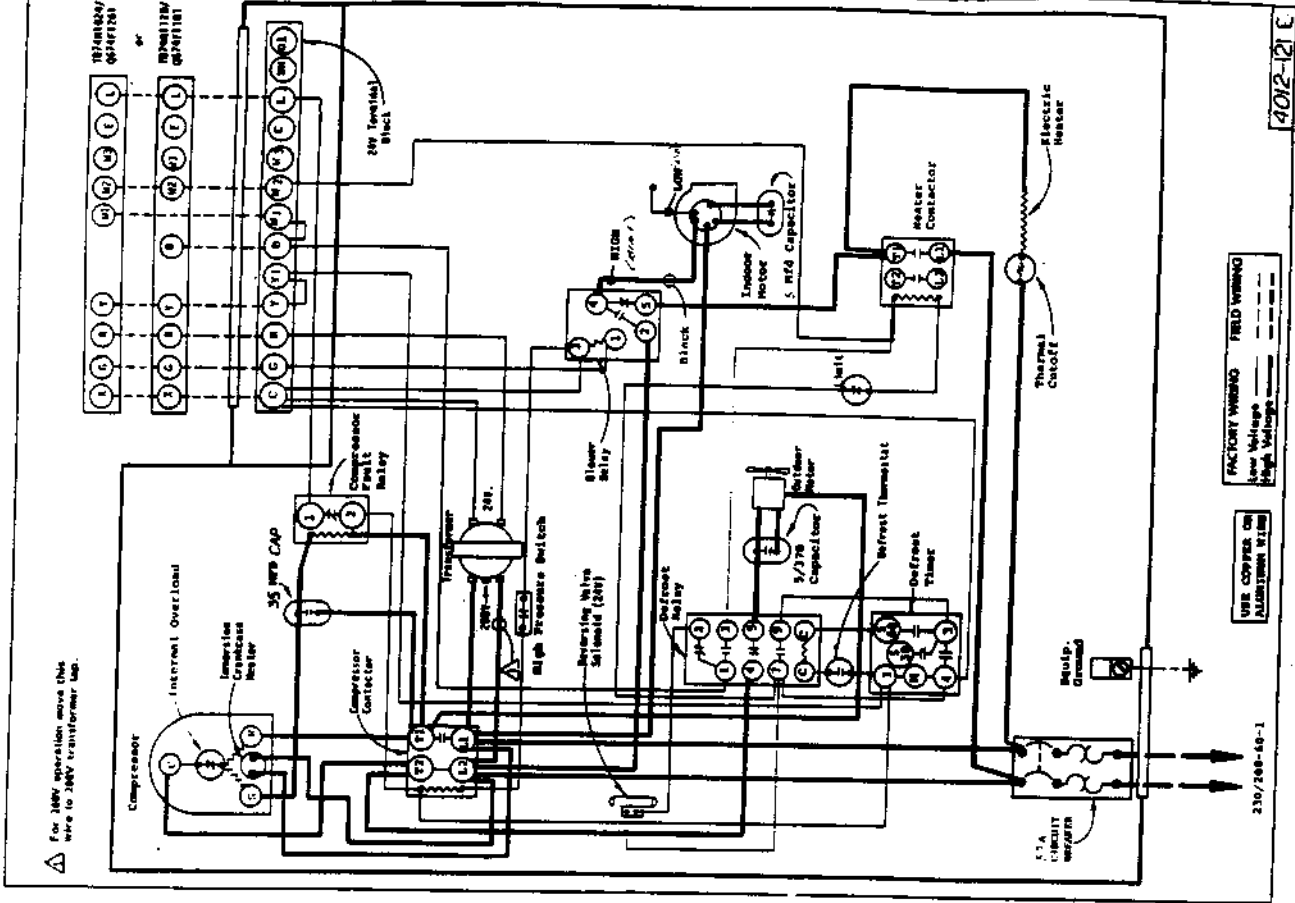

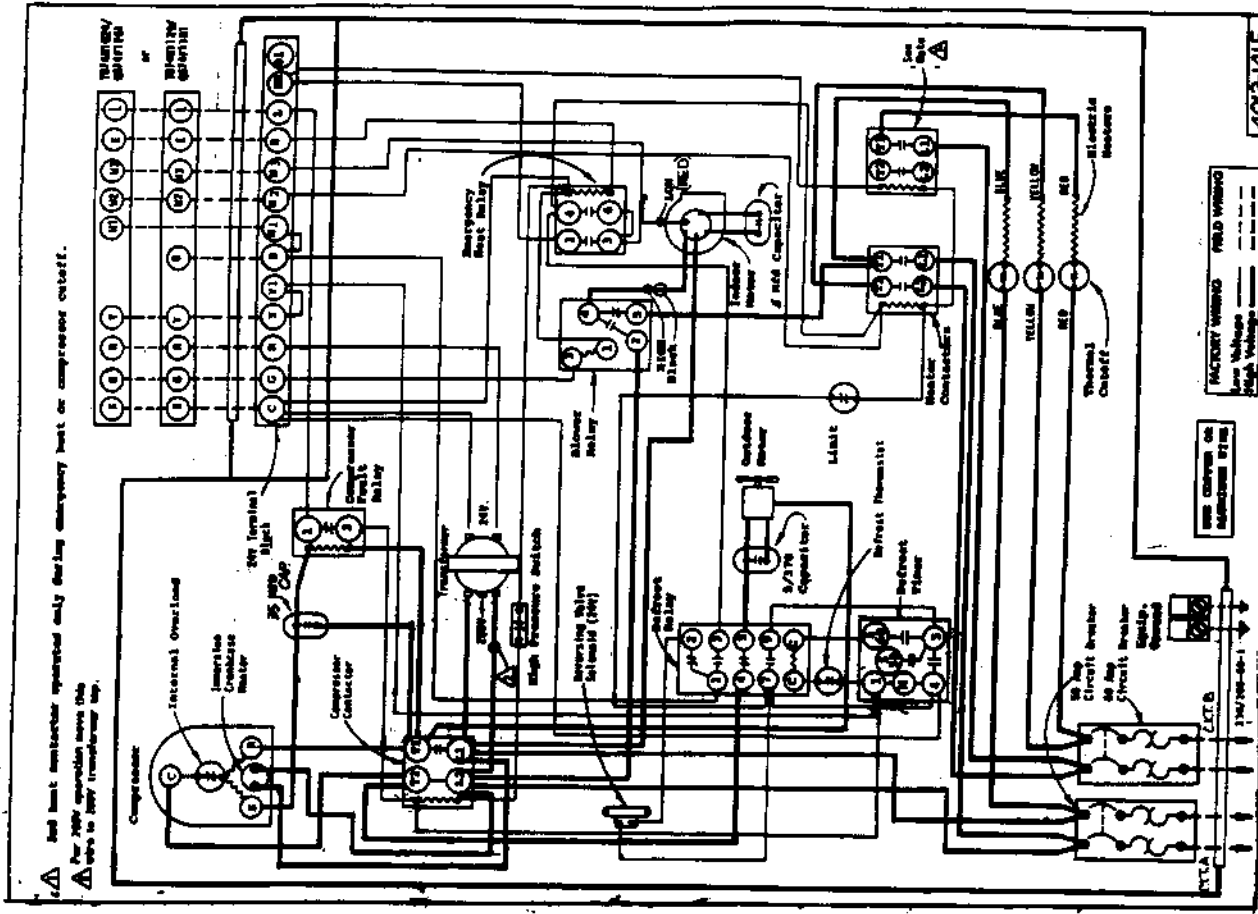
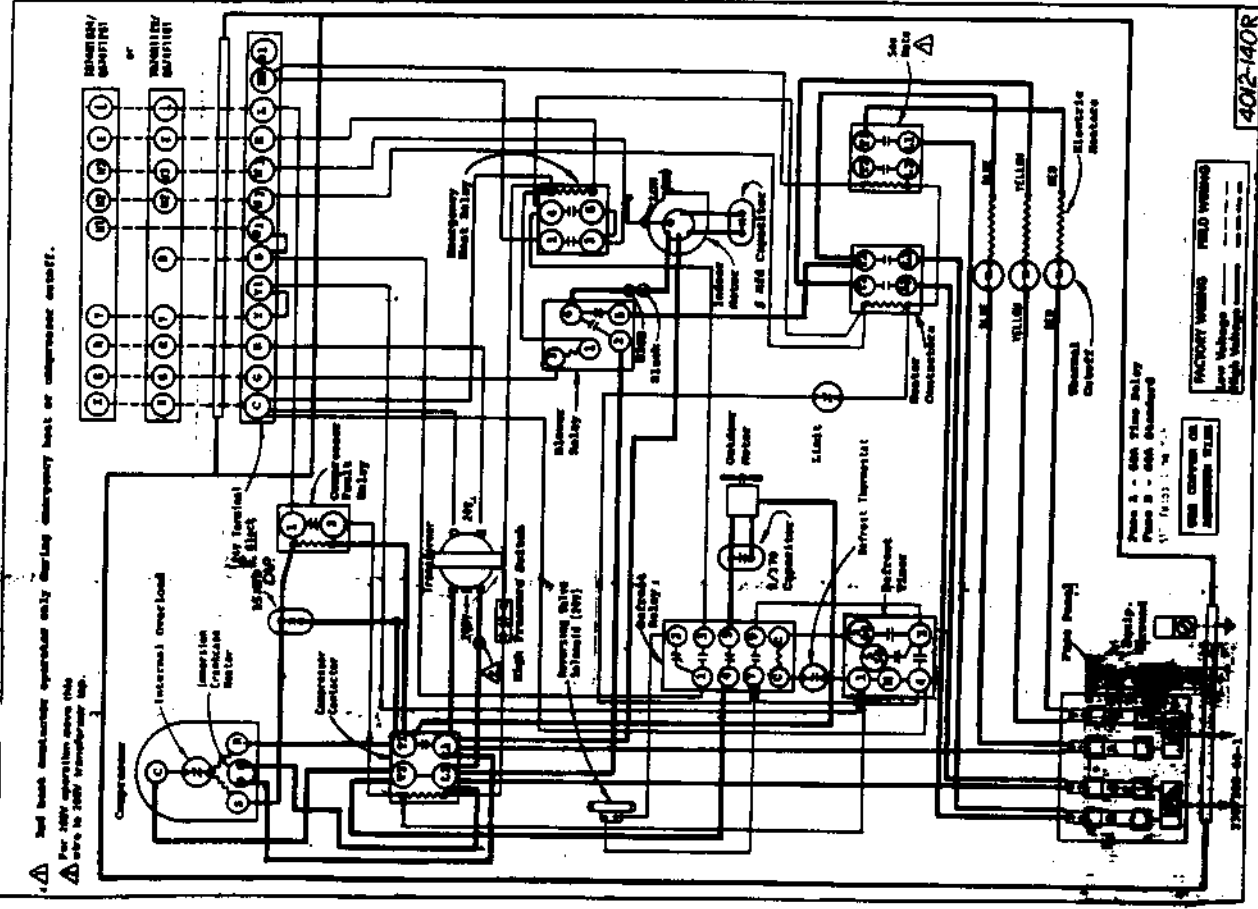

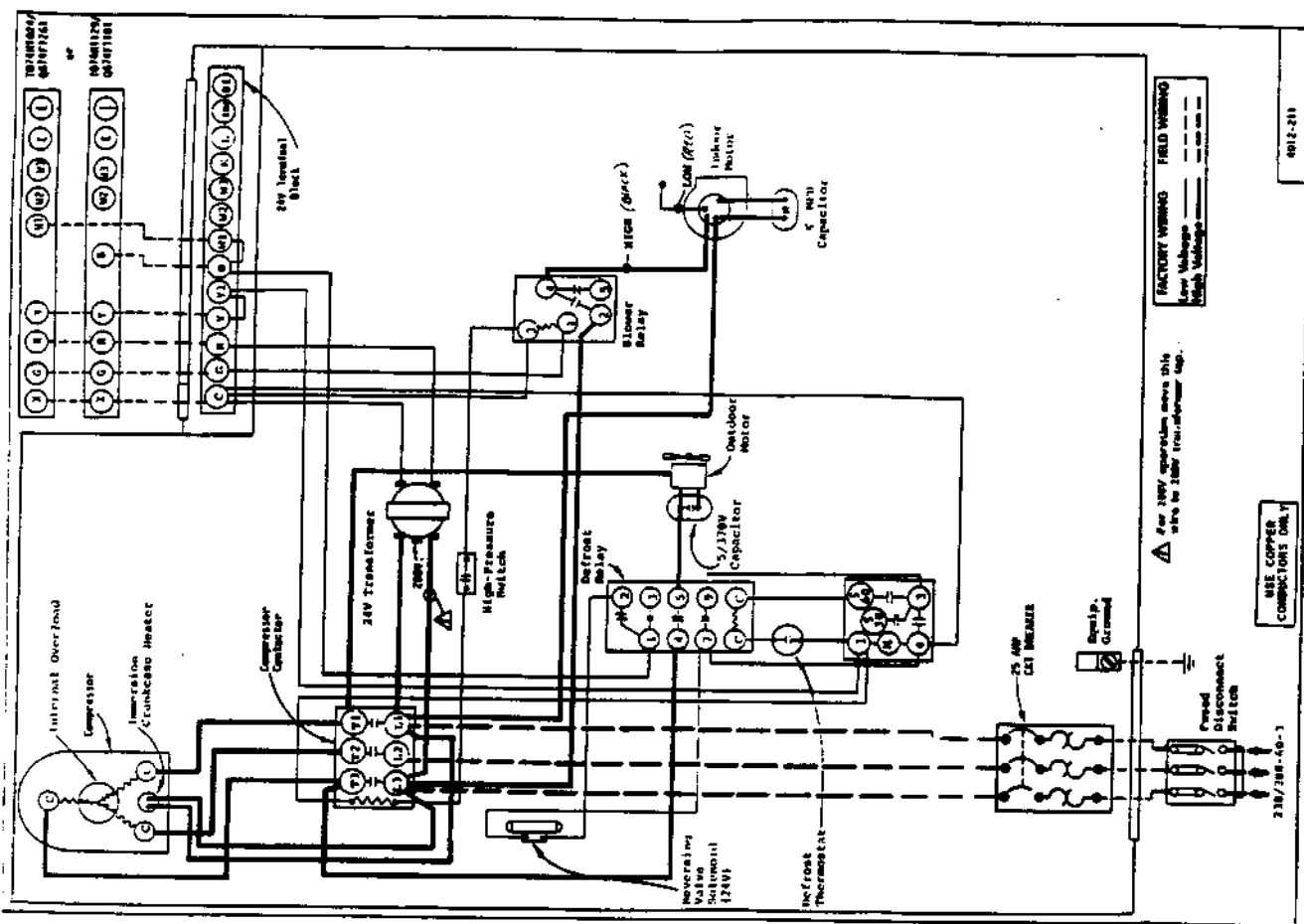
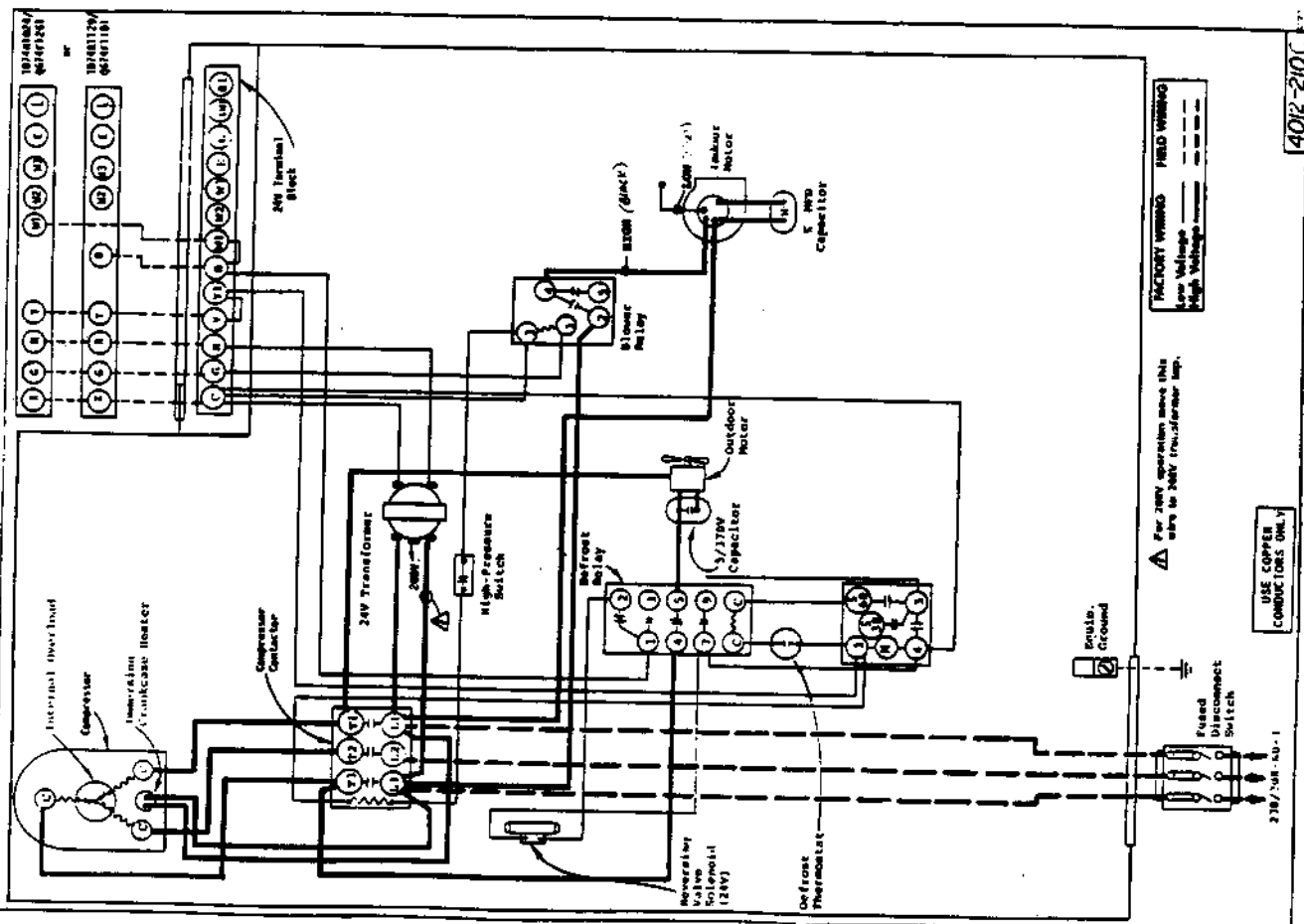

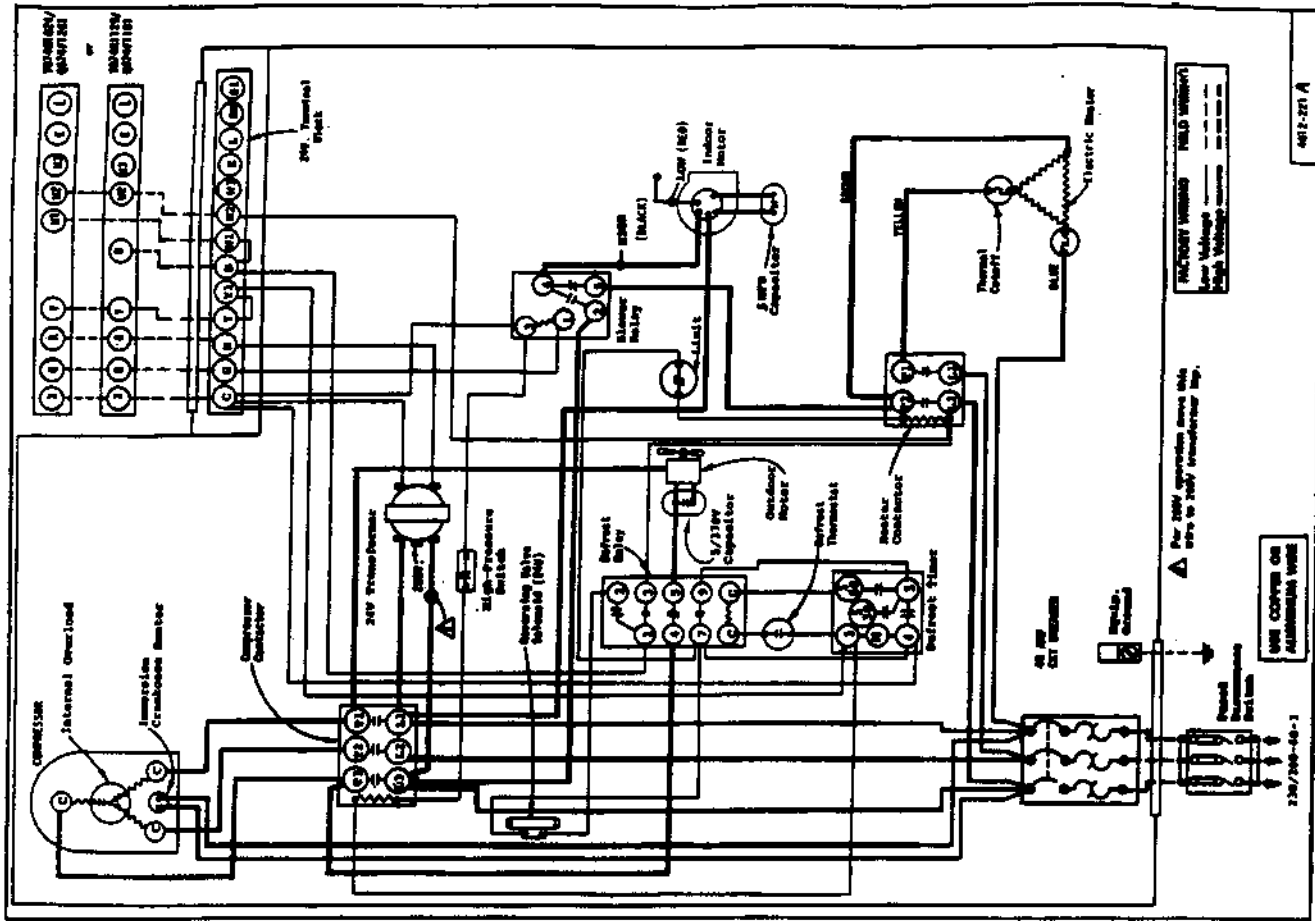

4012-271-A

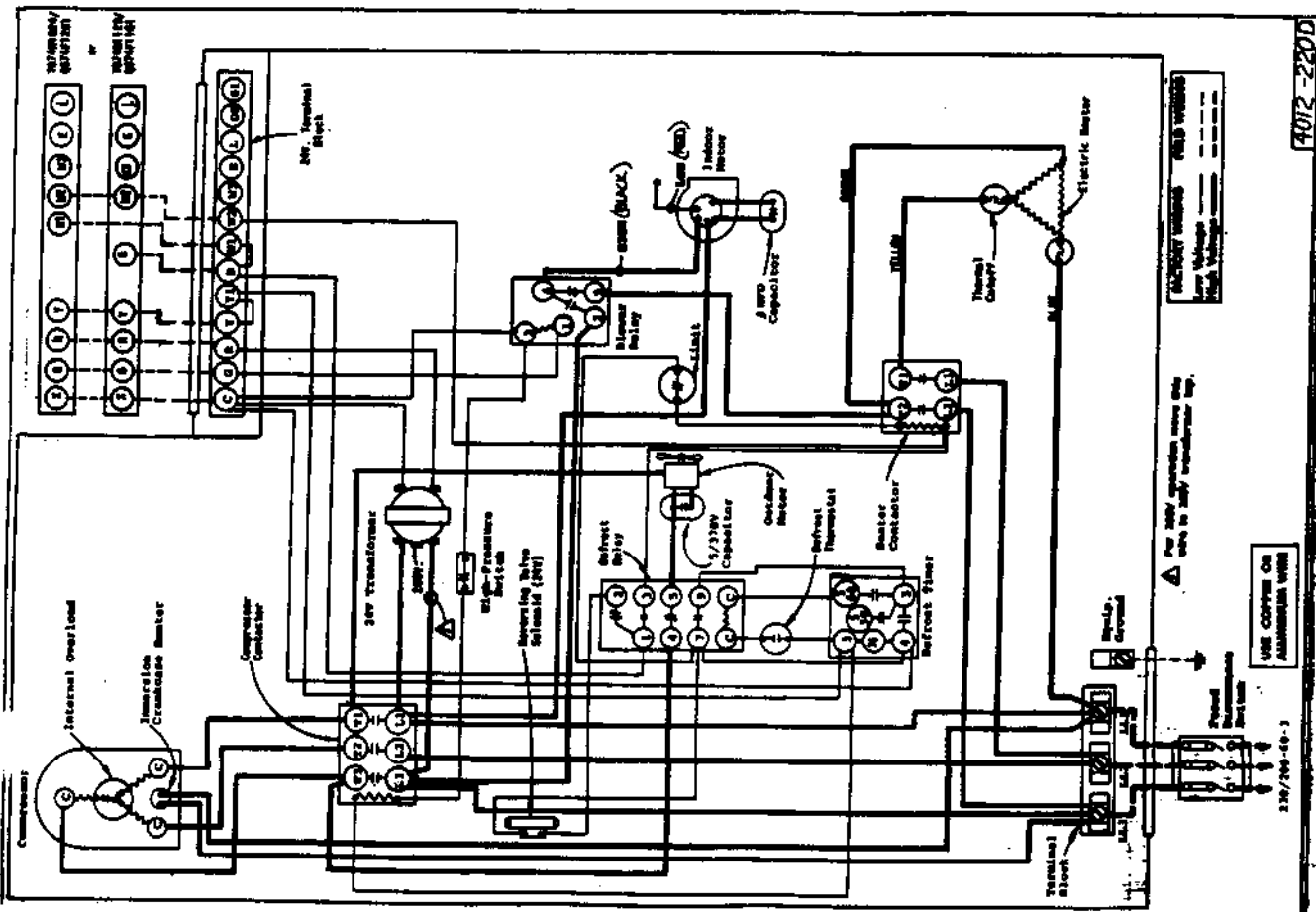

4012-270-D

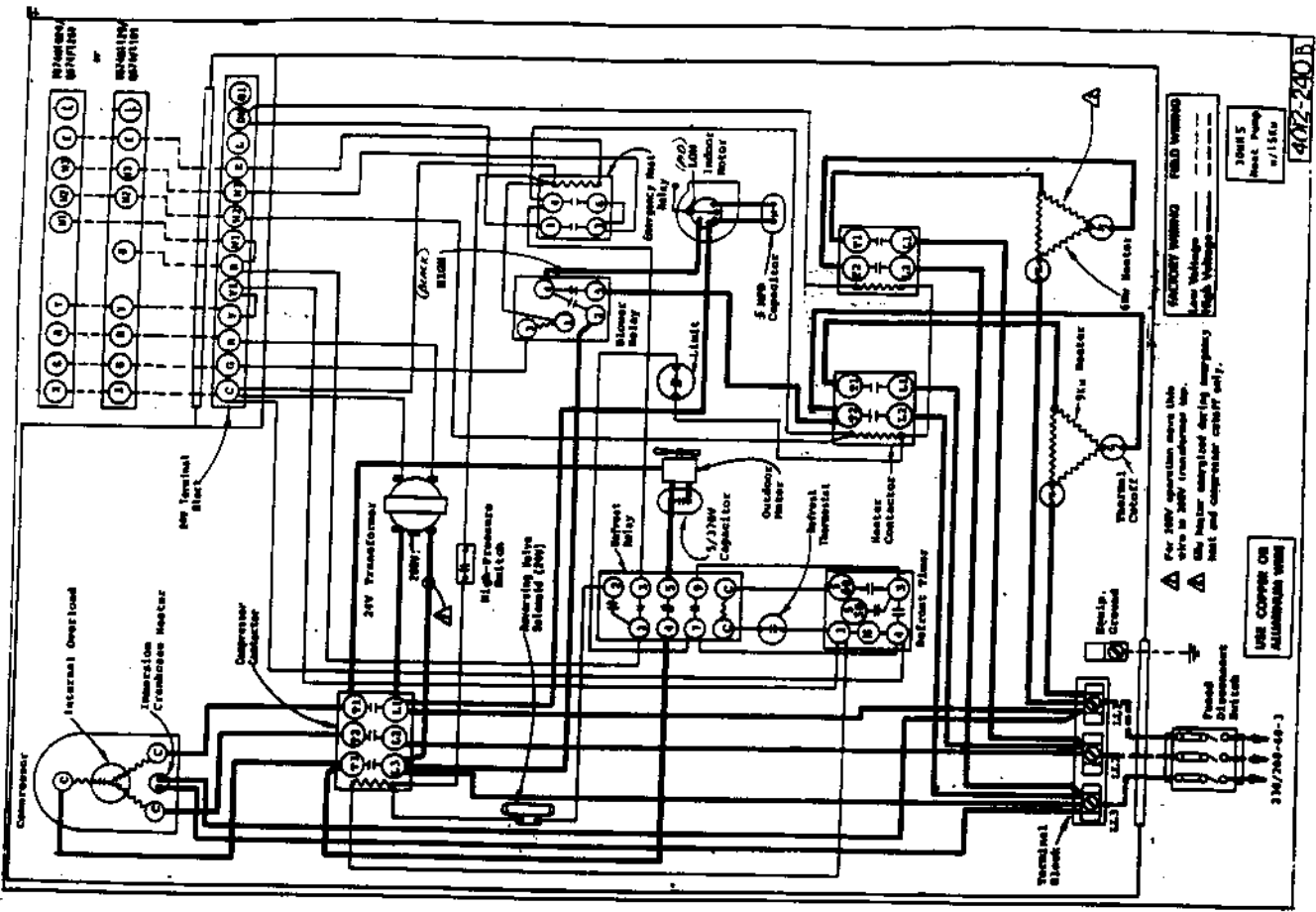
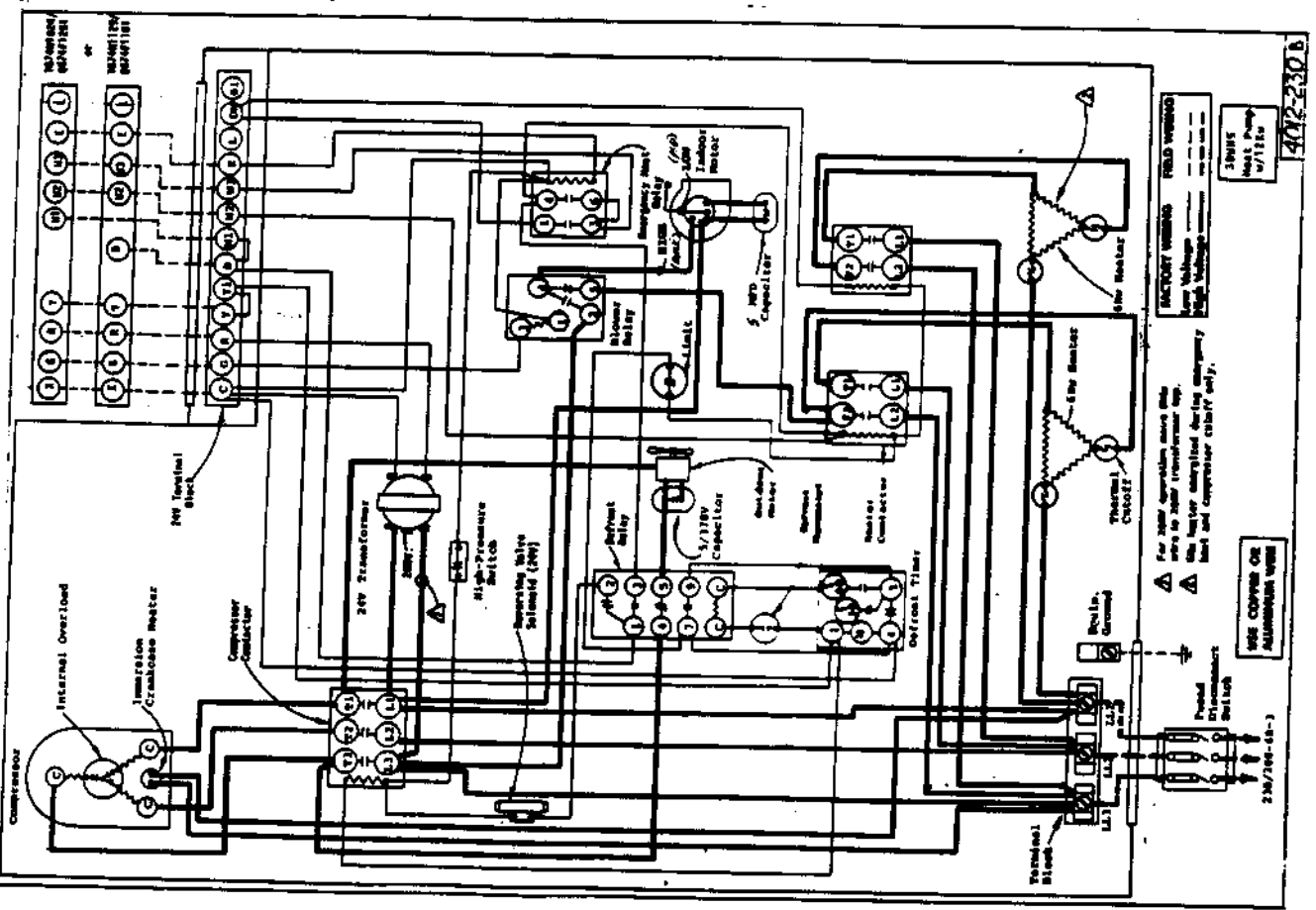

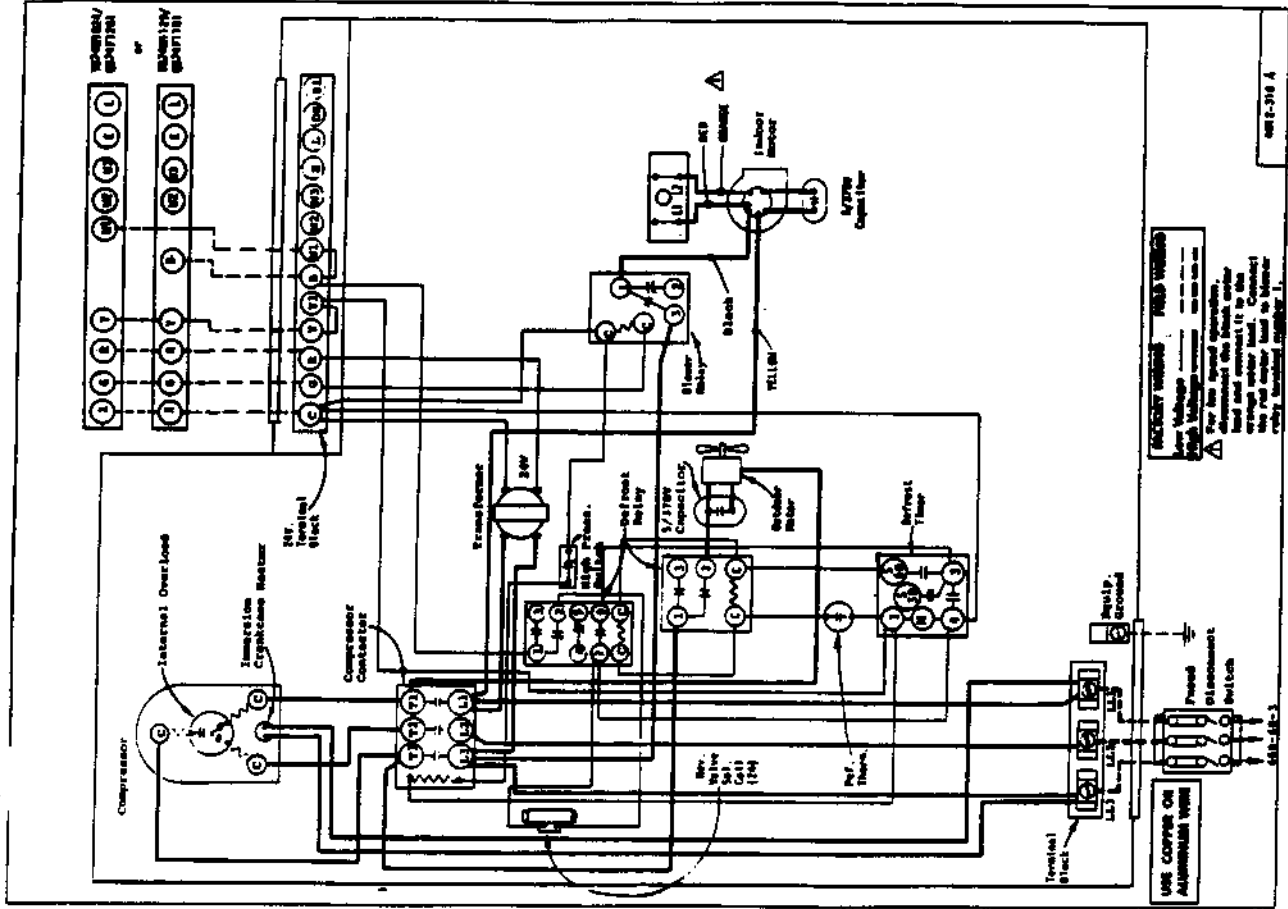
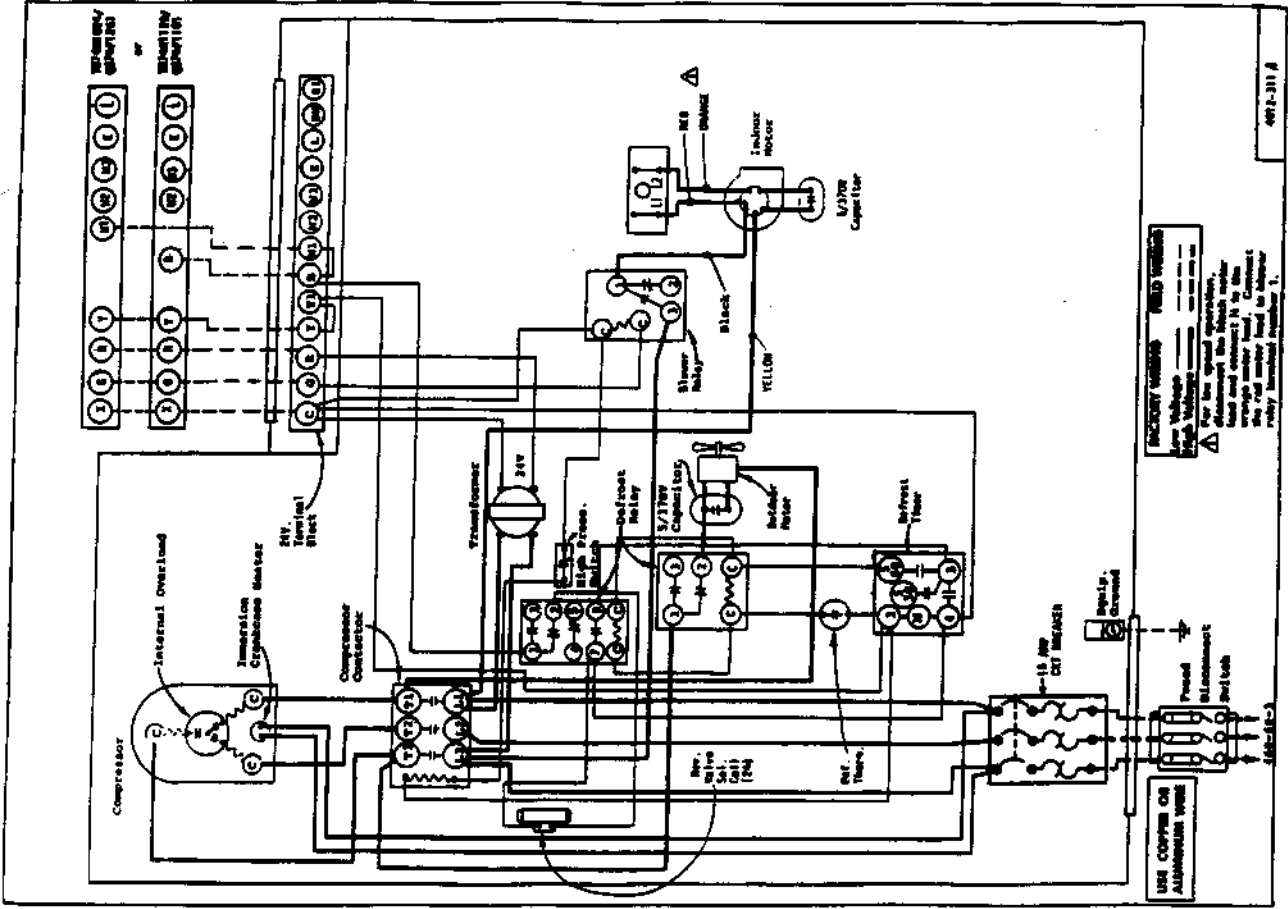

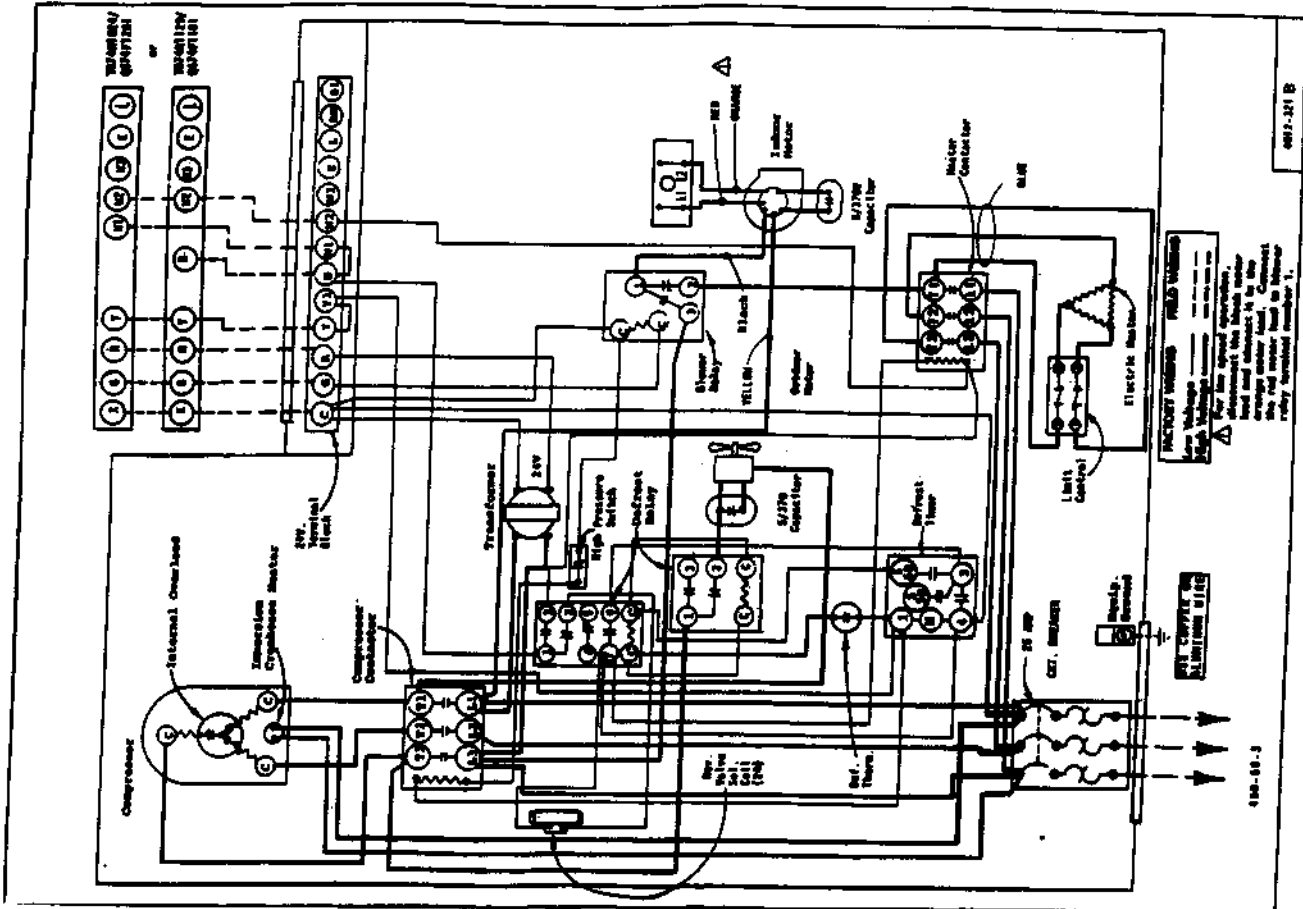
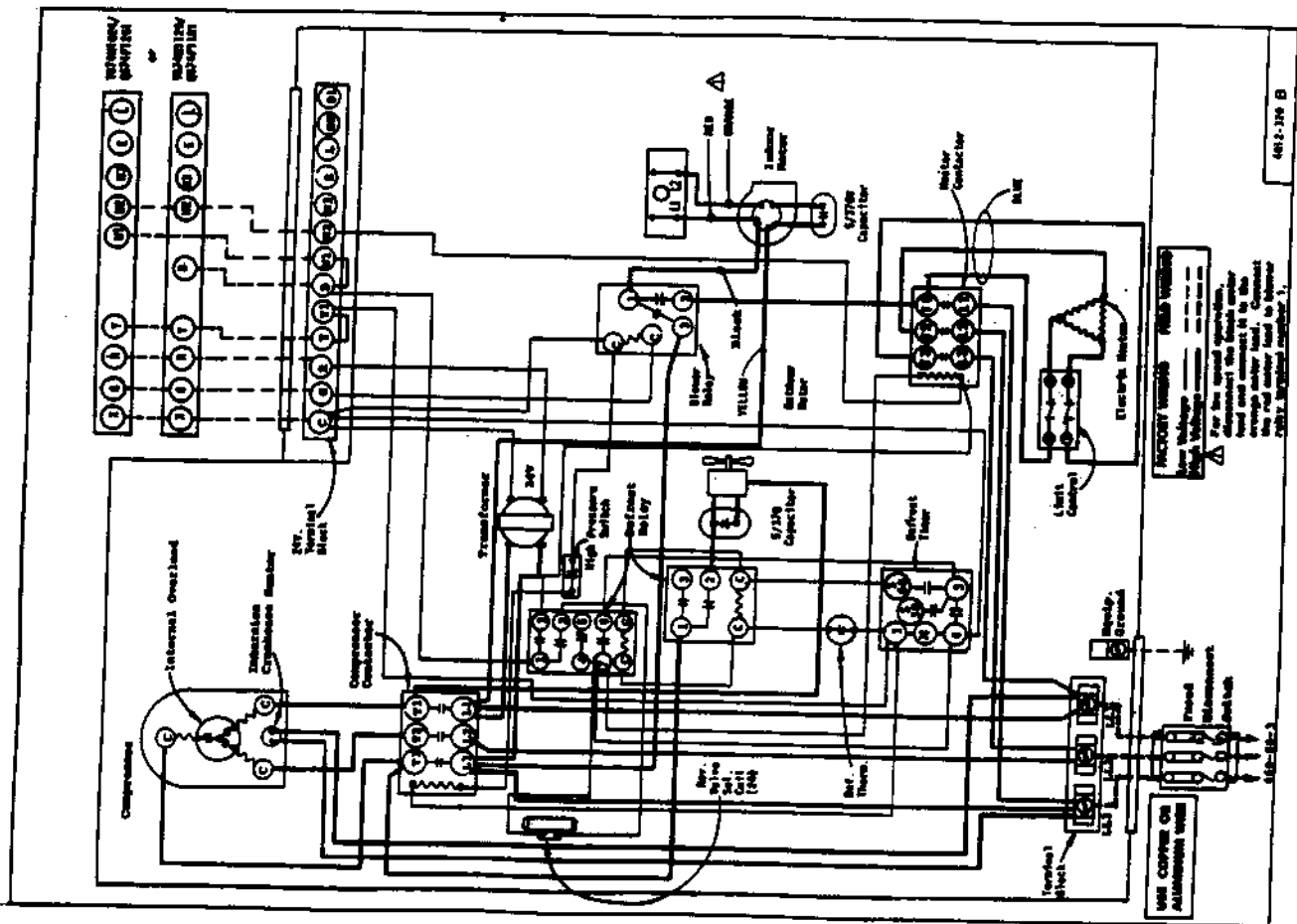

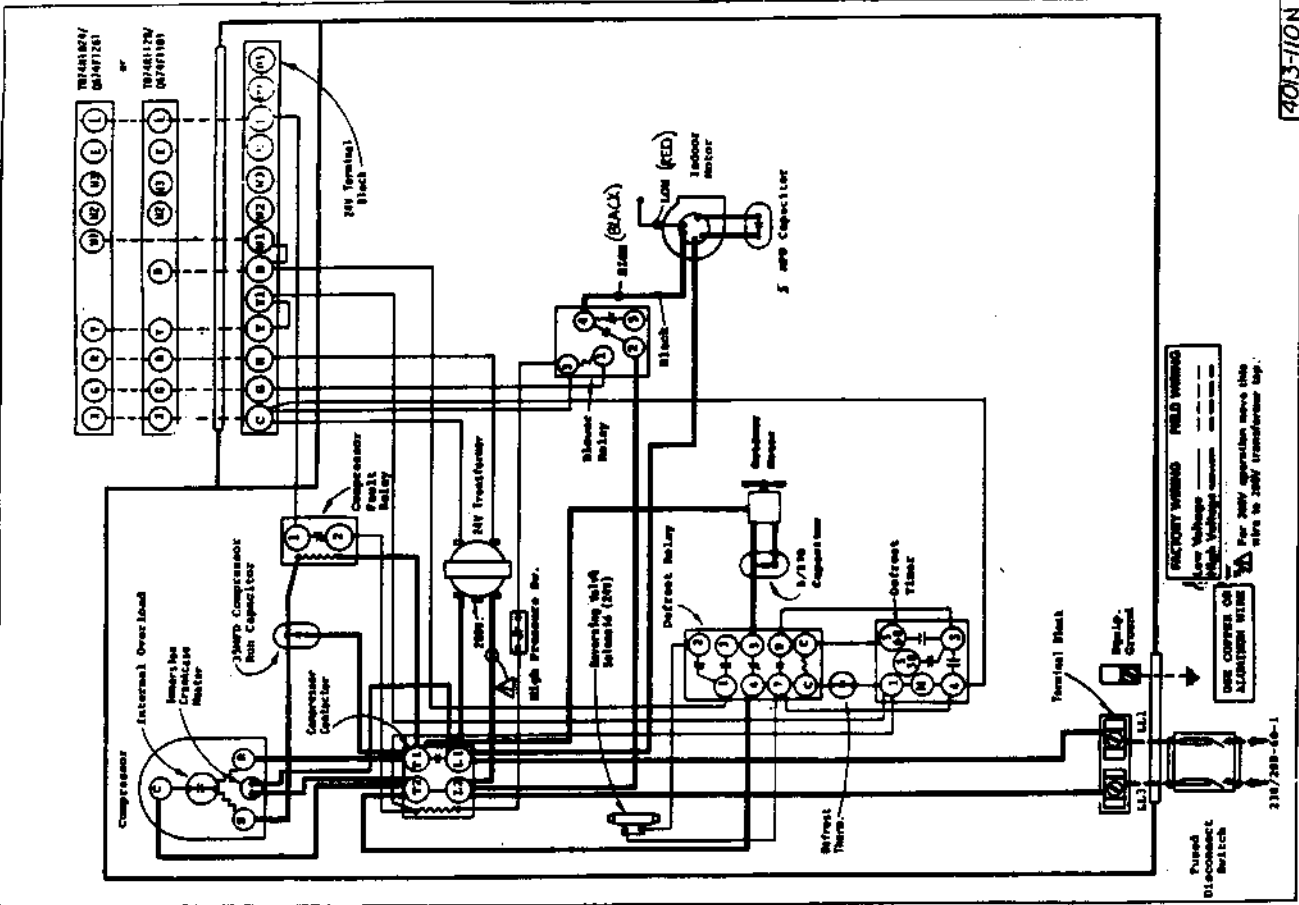

403-110

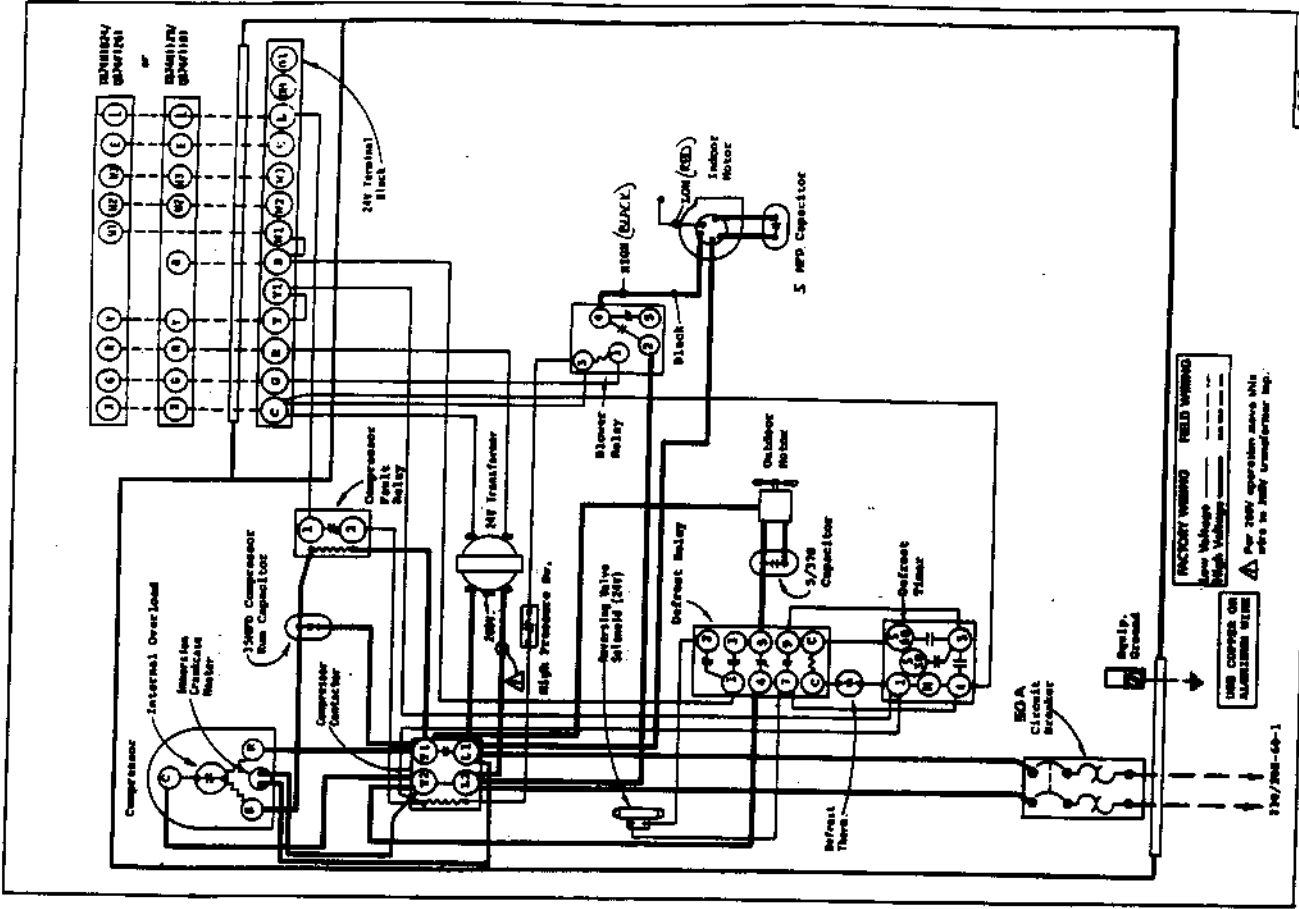

403-111

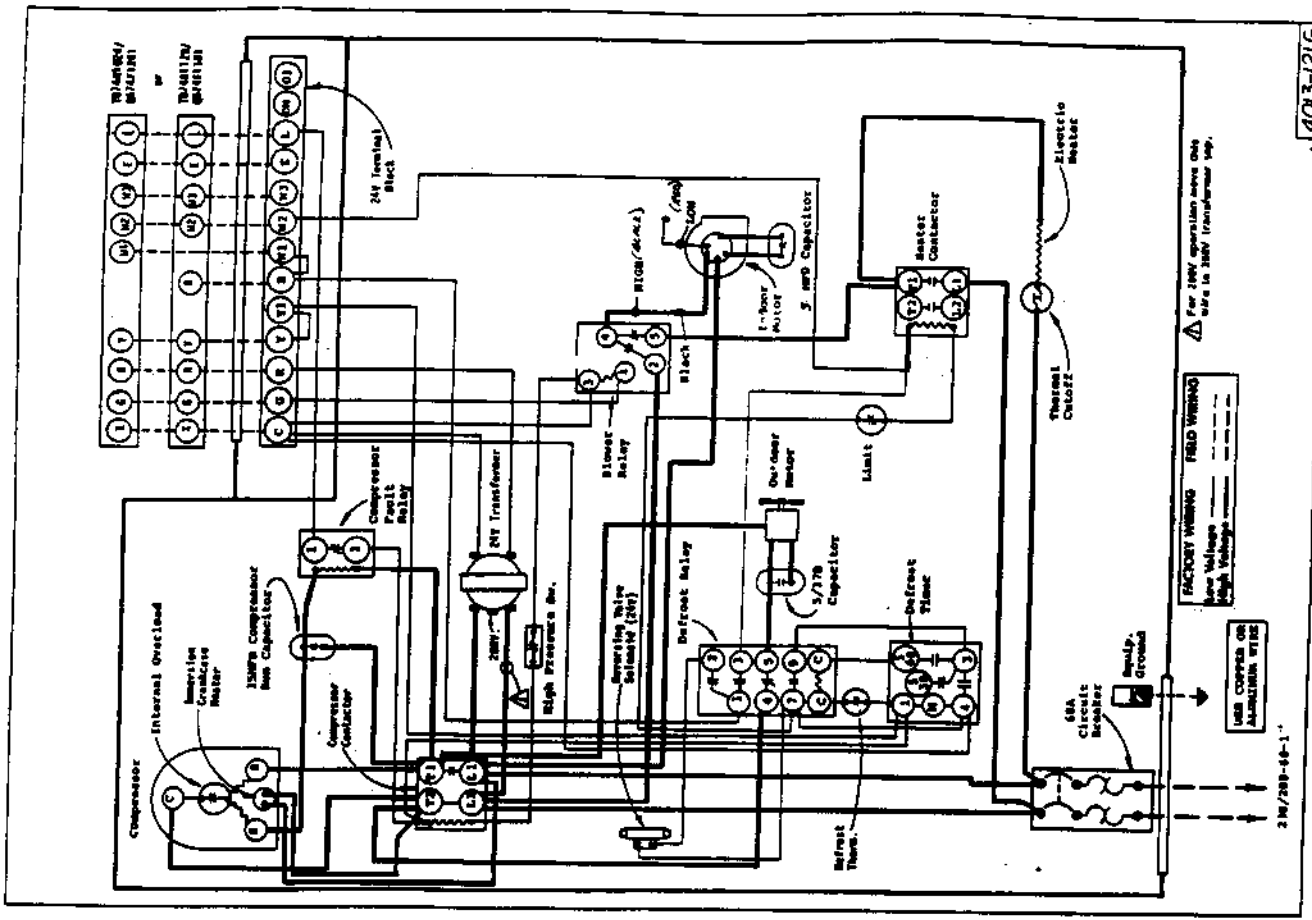
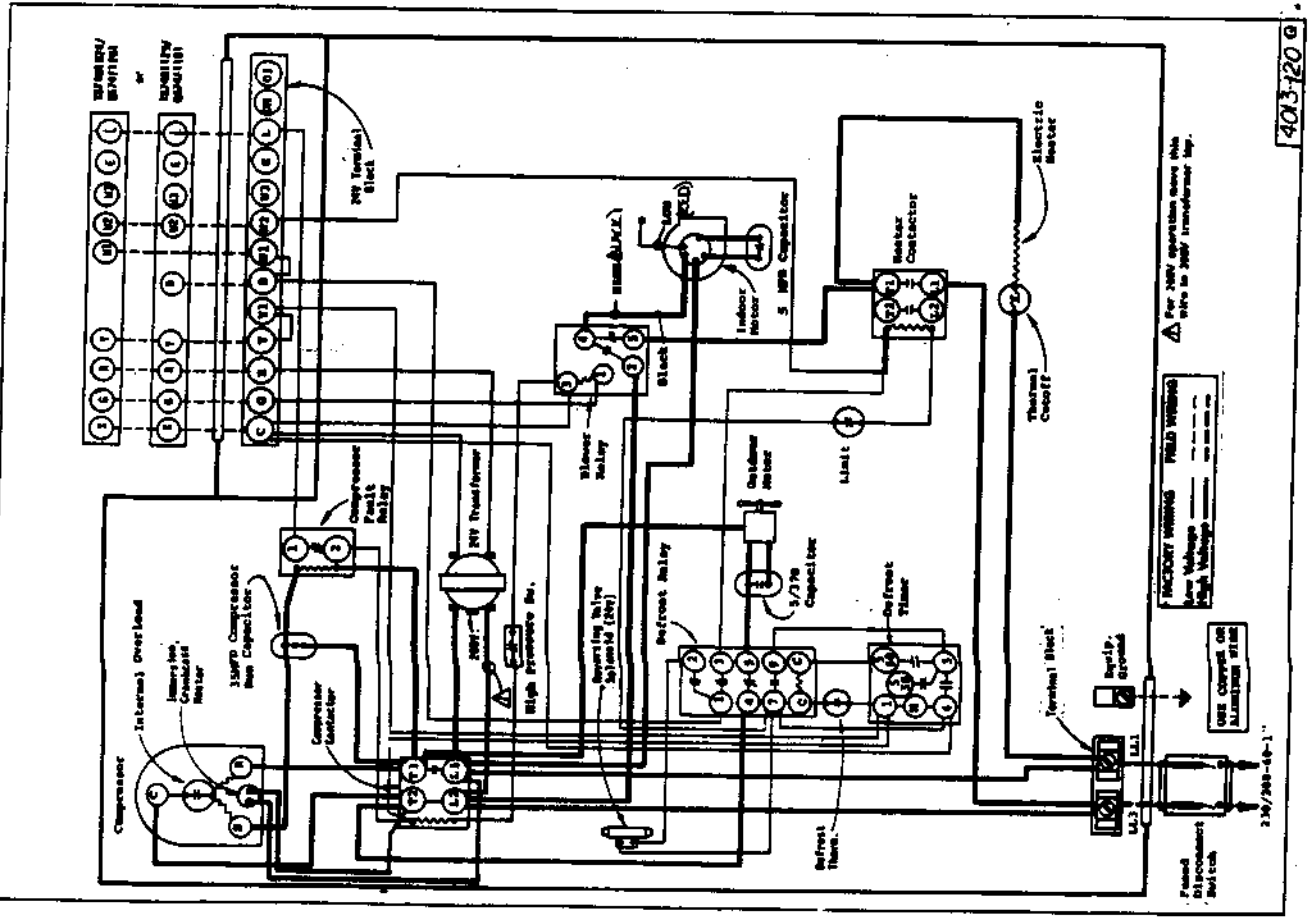

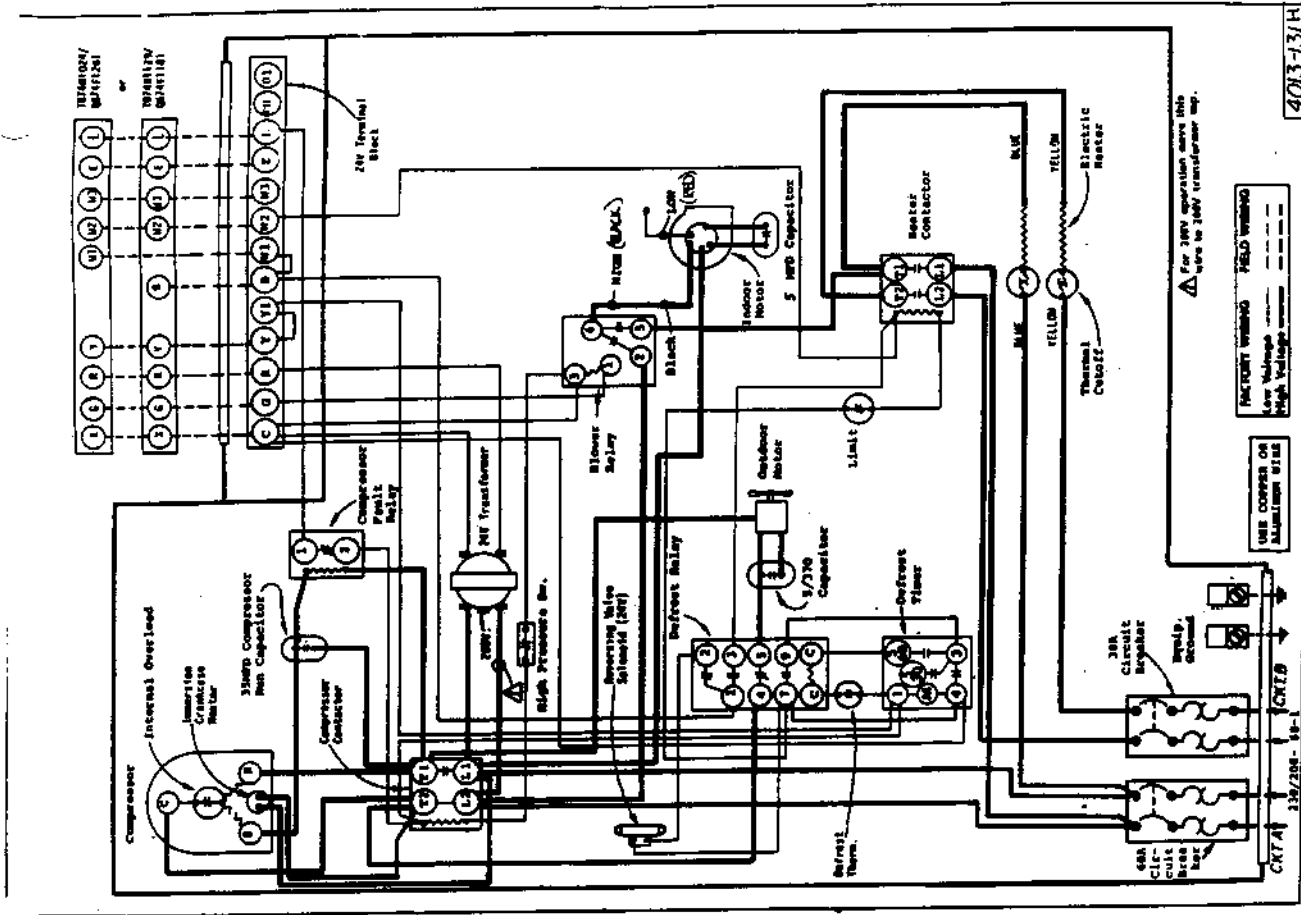
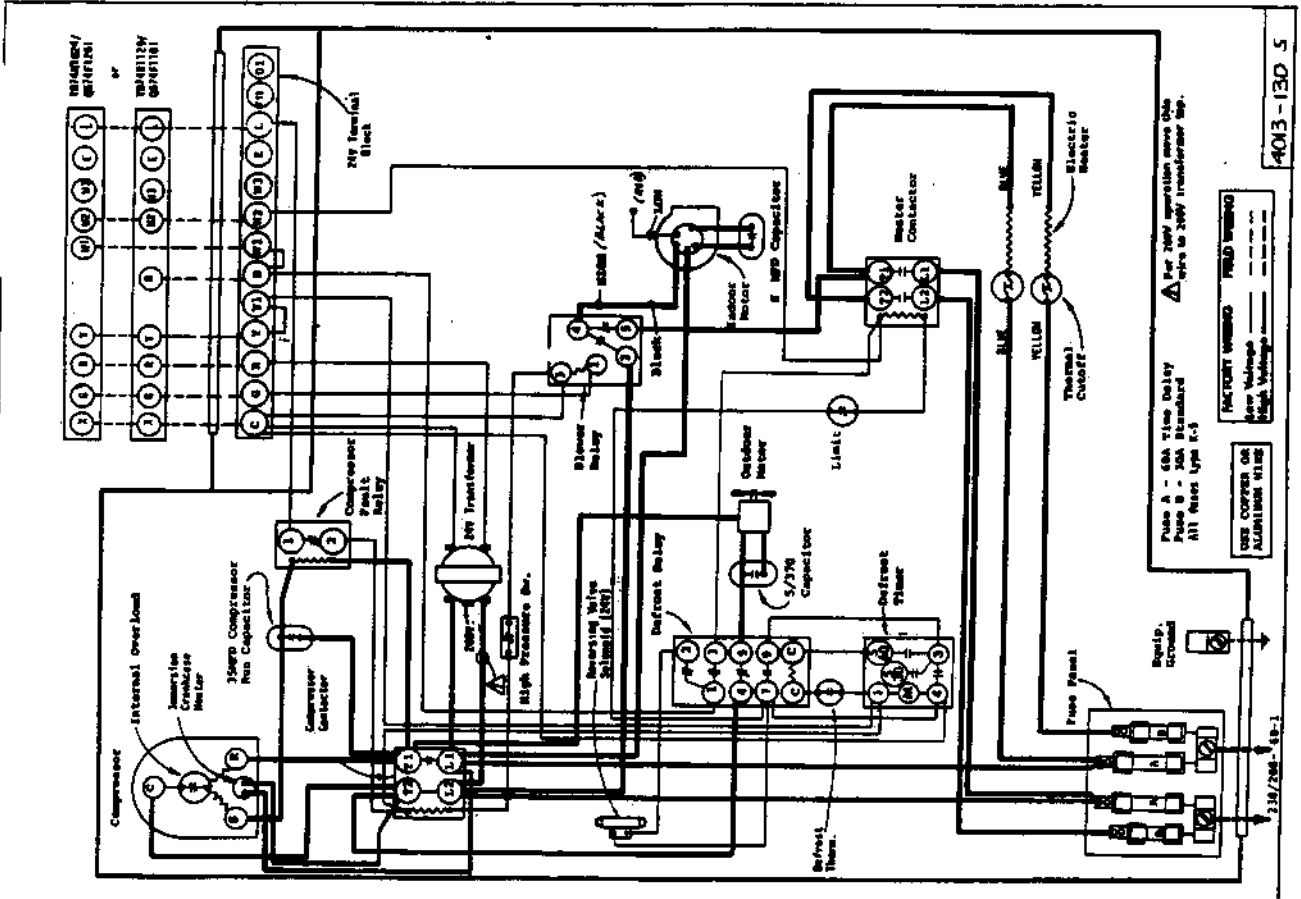

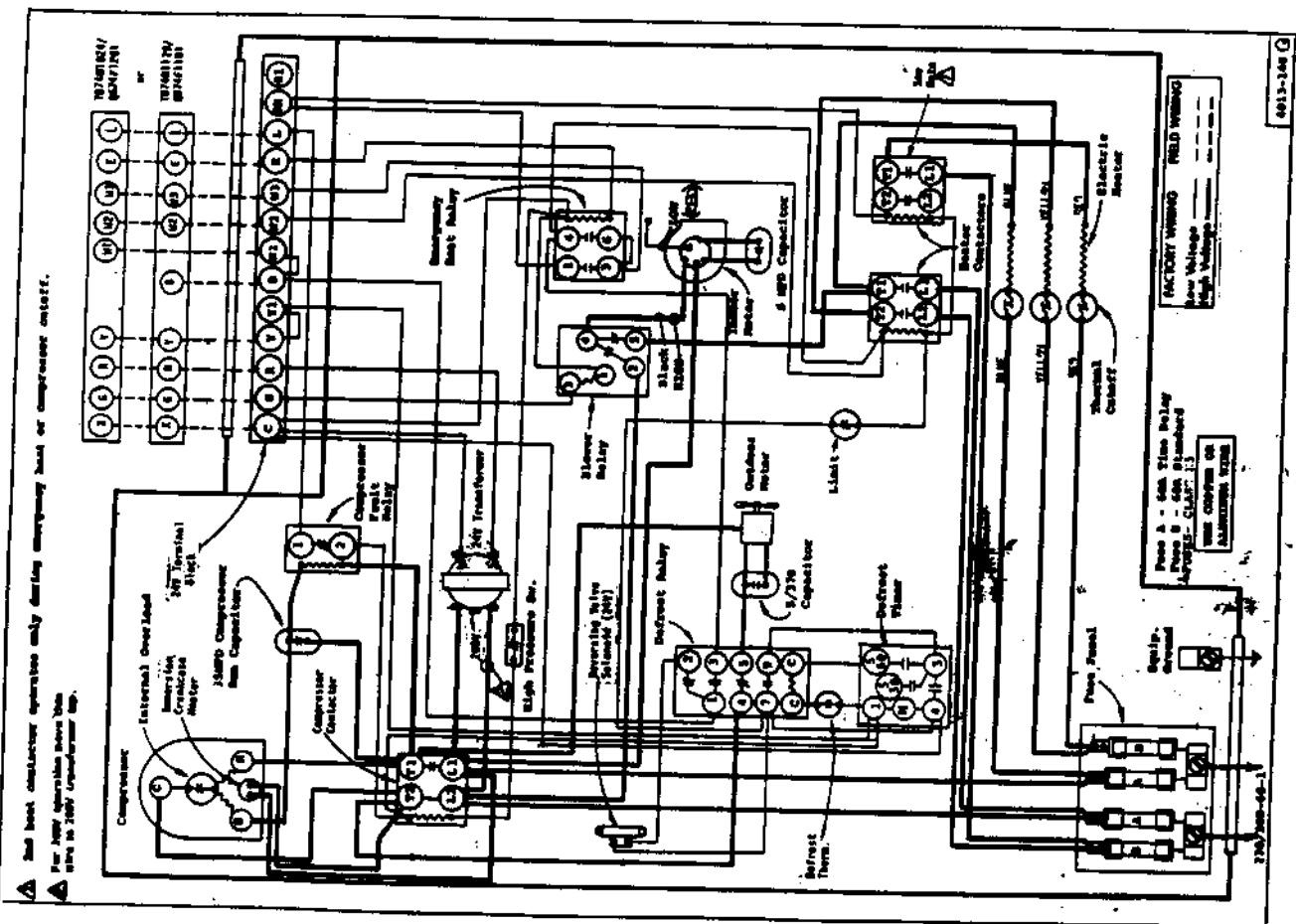
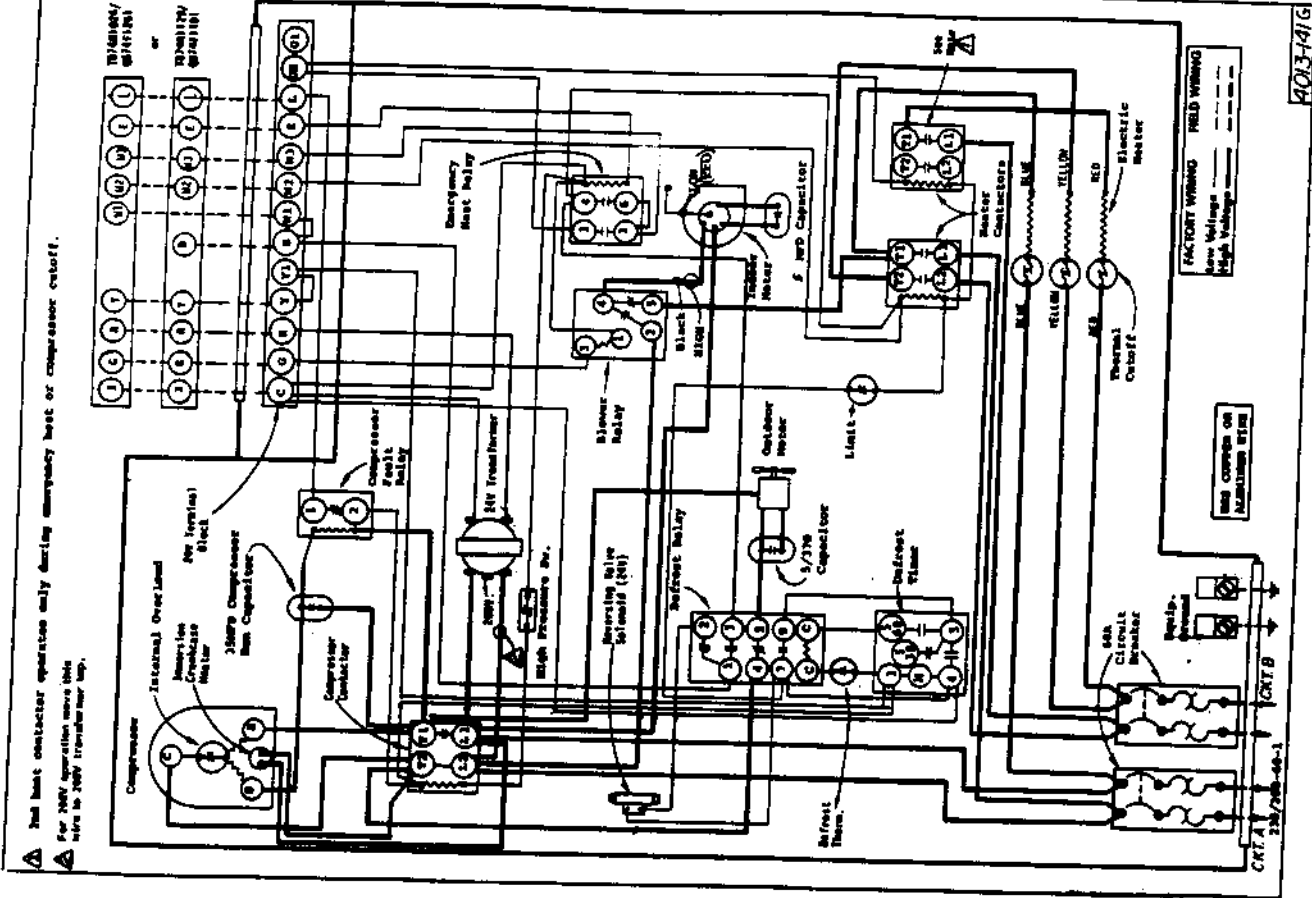

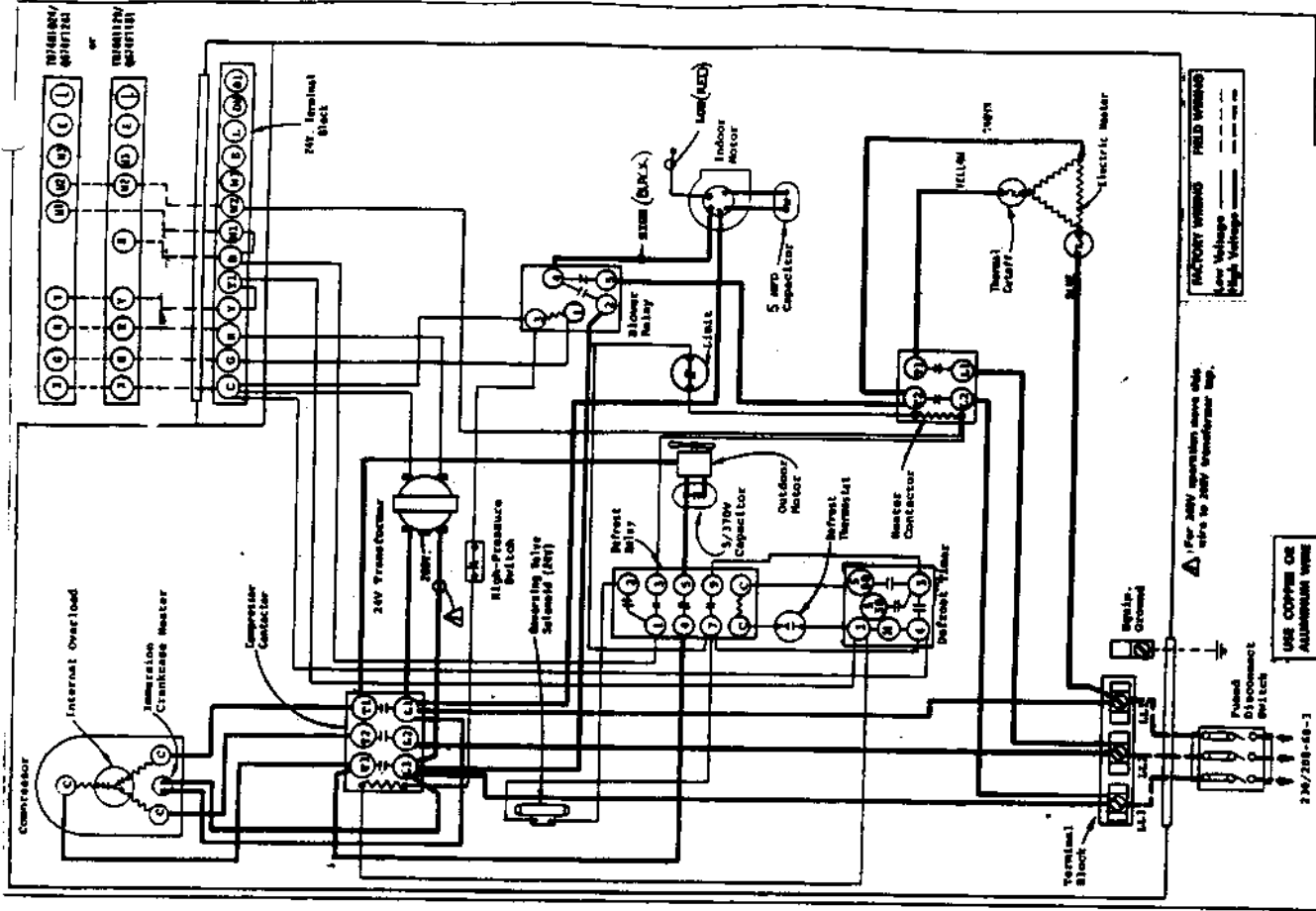
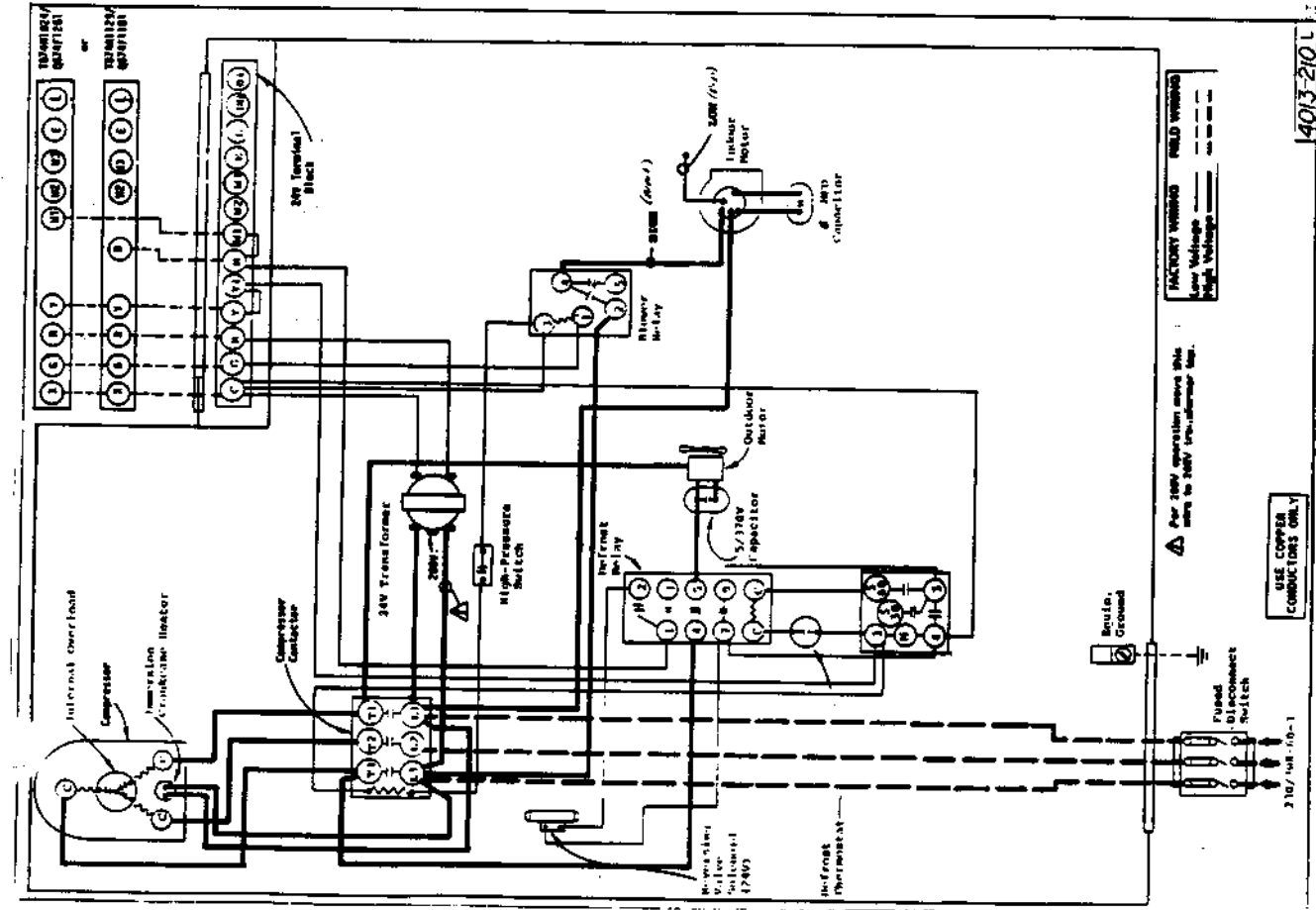

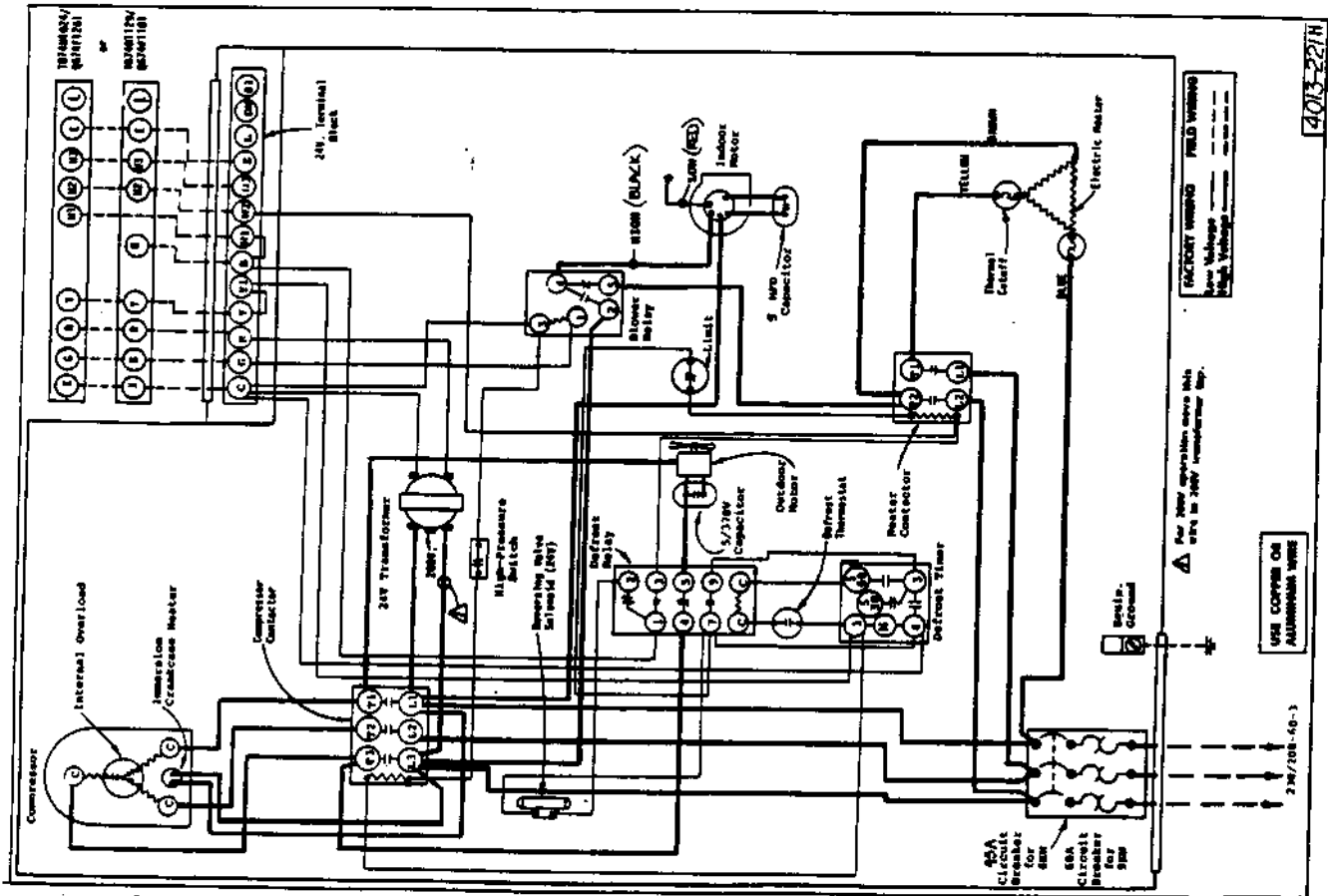
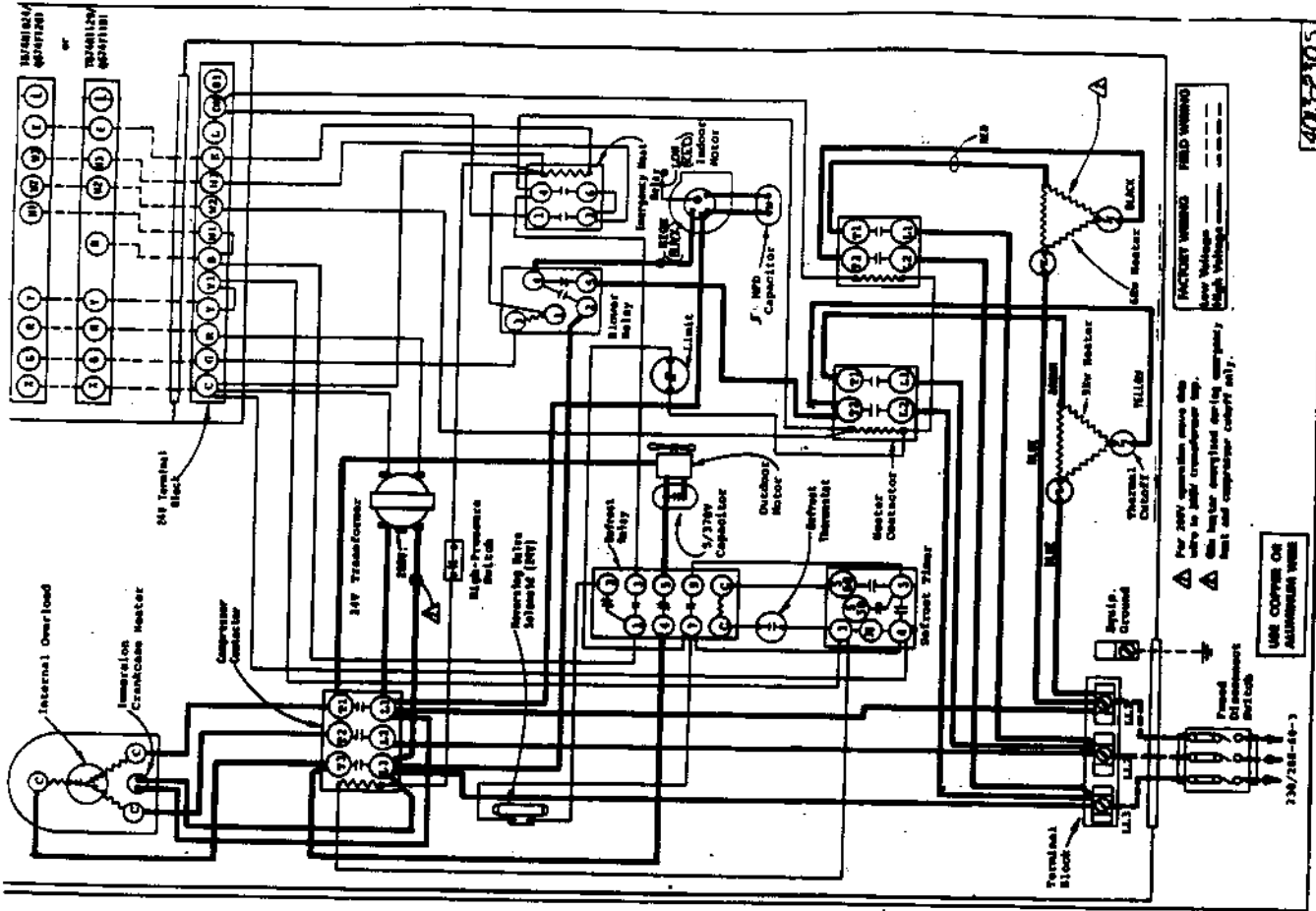

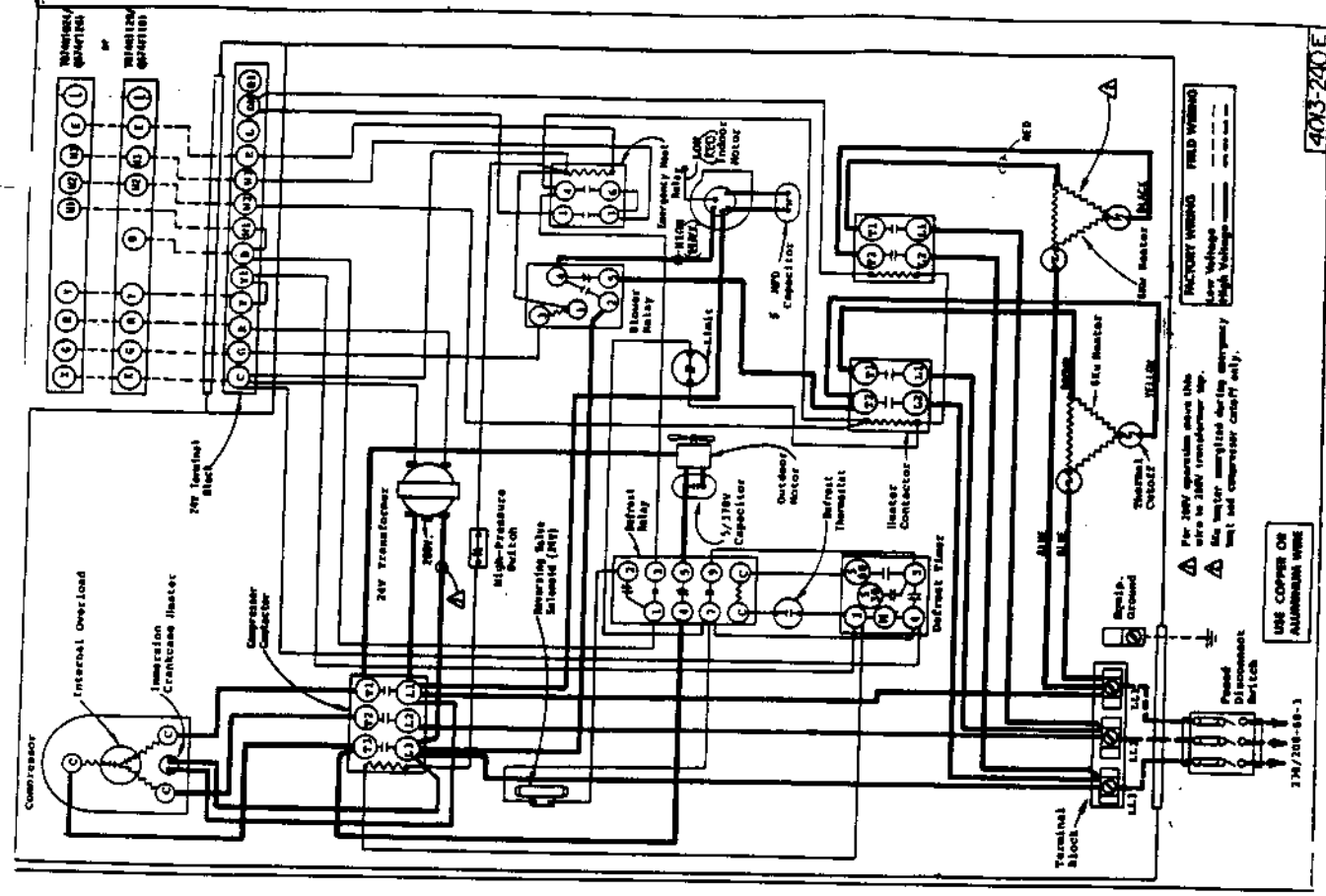

403-200E

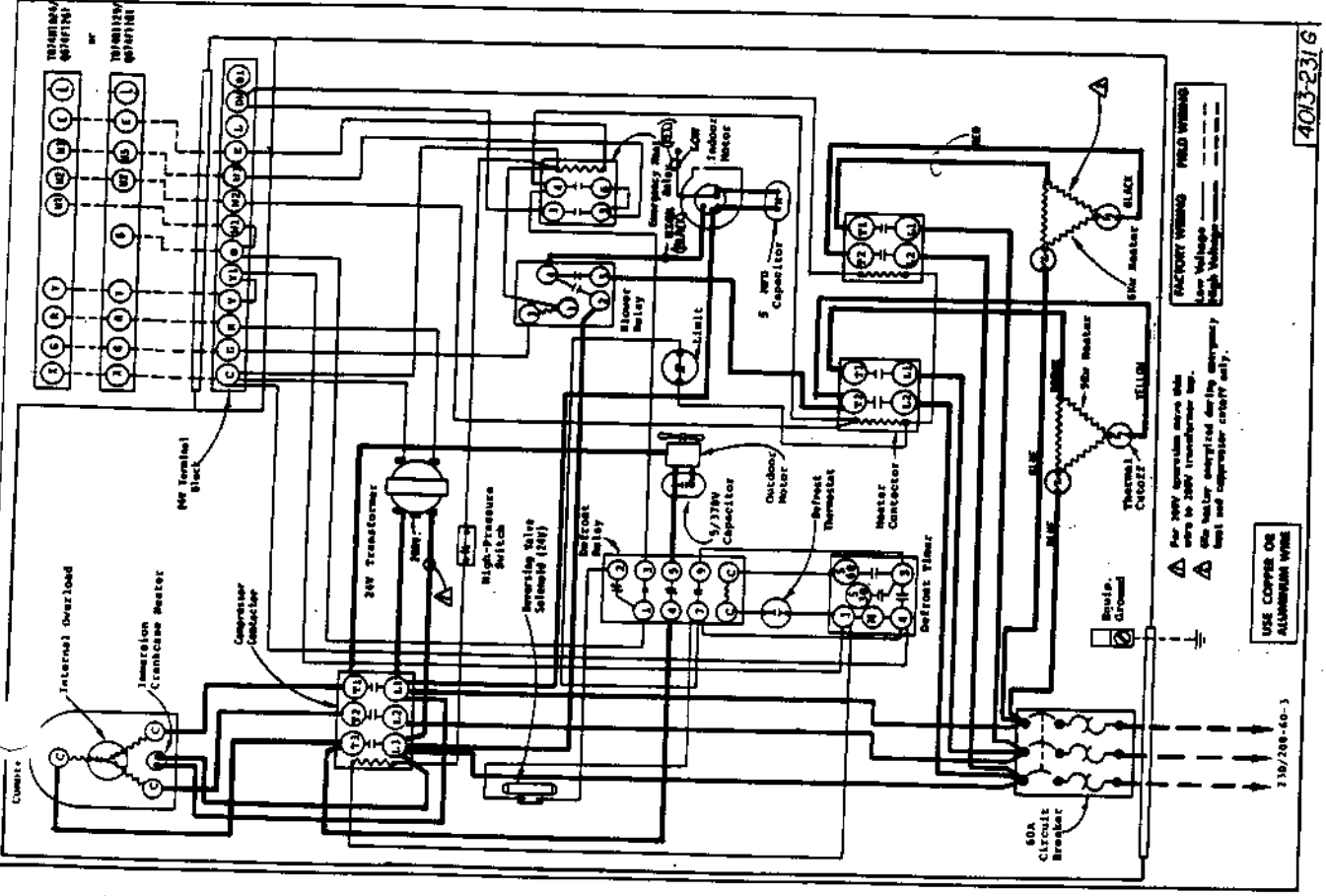

403-231G

