

# INSTALLATION INSTRUCTIONS

## MODELS

30HPQ6, 36HPQ7

## SPLIT HEAT PUMP UNIT OUTDOOR SECTIONS

FOR USE WITH  
MATCHING BARD INDOOR BLOWER  
COIL UNITS AND MATCHING  
ADD ON COIL ONLY UNITS

## IMPORTANT

The equipment covered in this manual is to be installed by trained, experienced service and installation technicians. Any heat pump is more critical of proper operating charge and an adequate duct system than a straight air conditioning unit. All ductwork, supply and return, must be properly sized for the design air flow requirement of the equipment. ACCA is an excellent guide to proper sizing. All ductwork or portions thereof not in the conditioned space should be properly insulated in order to both conserve energy and prevent condensation or moisture damage.

## SHIPPING DAMAGE

Upon receipt of equipment, the carton should be checked for external signs of shipping damage. If damage is found, the receiving party must contact the last carrier immediately, preferably in writing, requesting inspection by the carrier's agent.

## GENERAL

These instructions explain the recommended method to install the air-cooled split type heat pump, the interconnected refrigerant tubing, and the electrical wiring required for both unit power and control circuit.

These units are to be used in conjunction with the matching indoor coil sections as shown on the specification sheet. Only those combinations as shown are authorized or recommended.

These instructions and any instructions packaged with any separate equipment required to make up the entire heat pump system should be carefully read before beginning the installation. Note particularly any tags and/or local codes in any way. Authorities having jurisdiction should be consulted before the installation is made.

## PRESSURE SERVICE PORTS

High and low pressure service ports are installed on all units so that the system operating pressures can be observed. Pressure curves can be found later in the manual covering all models on both cooling and heating cycles. It is imperative to match the correct pressure curve to the unit by model number.

## SETTING THE UNIT

**General** - The unit must be located outside, or in a well ventilated area. It must not be in the space being heated or cooled. A sound absorbing material should be considered if the unit is to be installed in such a position or location that might cause transmission of sound or vibration to the living area or adjacent buildings.

## SLAB MOUNTING

In areas where winter temperatures DO NOT go below 32°F for periods over twelve hours, the unit may be slab mounted at grade level. When installing unit at grade level, install on a concrete slab at least four inches above finished grade level. Slab should have a slope tolerance away from the building structure of at least 1/4 inch per foot, while being level from side to side. This will prevent ice buildup under the unit during defrost cycles. Place slab in a location where run-off water from higher ground will not collect around unit. See Figure 1.

A minimum of 18 inches should be provided between the coil inlet and any building surfaces. Provide at least four feet between coil outlet and any building wall, fences or other vertical structures. Provide a minimum of three feet clearance on the service access side of the unit. Refer to Figure 2.

## ROOF MOUNTING

When a unit is installed in areas where low ambient temperatures or strong winter winds exist, it should be placed so prevailing winter winds are not in direct line with the heat pump coil. If this is not possible, a wind barrier should be constructed. Place barrier 24 inches from the coil inlet side of the unit and in the direction of prevailing winds. Size barrier at least the same height and width as the unit. See Figure 3.

## WINTER INSTALLATION BELOW 32°F

In areas where winter conditions go below 32°F for extended periods, the unit must be elevated above the mounting surface to prevent snowfall or defrost ice accumulation from interfering with the operation of the unit. A minimum of twelve inch elevation is recommended, while greater elevation may be required for areas of high snow accumulation. Poured concrete, steel framework, brick, cement block, etc. can be utilized to construct a suitable raised mounting platform. See Figure 4.

## WIRING - MAIN POWER

Refer to the unit rating plate for wire sizing information and maximum fuse or "HACR Type" circuit breaker size. Each outdoor unit is marked with a "Minimum Circuit Ampacity." This means that the field wiring used must be sized to carry that amount of current. Depending on the installed Kw of electric heat, there may be two field power circuits required. If this is the case, the unit serial plate will so indicate. Some models are suitable only for connection with copper wire, while others can be wired with either copper or aluminum wire. Each unit and/or wiring diagram will be marked "Use Copper Conductors Only" or "Use Copper or Aluminum Conductors." These instructions MUST BE adhered to. Refer to the National Electrical Code for complete current carrying capacity data on the various insulation grades of wiring material.

The unit rating plate lists a "Maximum Time Delay Fuse" or "HACR Type" circuit breaker that is to be used with the equipment. The correct size must be used for proper circuit protection and also to assure that there will be no nuisance tripping due to the momentary high starting current of the compressor motor.

## WIRING - CONTROL CIRCUIT

Since the same outdoor unit can in most cases be matched with more than one indoor unit, the appropriate control circuit wiring diagrams are included with the indoor coil section installation instructions. These control circuit wiring diagrams cover all the available wiring options required in the various geographic areas of the country.

## REFRIGERANT CHARGE

The correct system R-22 is shown on the unit rating plate. Optimum unit performance will occur with a refrigerant charge resulting in a suction line temperature (6" from compressor) as shown in the following table:

Models	Rated Airflow	95°F O.D. Temp	82°F O.D. Temp.
30HPQ6/B30EHQ 30HPQ6/B36EHQ1	800 1060	51 - 53 53 - 55	57 - 59 63 - 65
*30HPQ6/A36AQ-A 36HPQ7/B36EHQ1	1130 1240	48 - 50 50 - 52	56 - 58 64 - 66
*36HPQ7/A36AQ-A	1200	48 - 50	58 - 60

NOTE: The suction line temperatures are based upon 80°F dry bulb/67°F wet bulb (50% R.H.) temperature and rated air flow across the evaporator during cooling cycle.

\*NOTE: Requires 5625-067 orifice to be installed in indoor coil.

## SEQUENCE OF OPERATION

**Cooling** - Circuit R-Y makes at thermostat pulling in compressor contactor starting the compressor and outdoor motor. The G (indoor motor) circuit is automatically completed on any call for cooling operation, or can be energized by manual fan switch on subbase for constant air circulation.

**Heating** - A 24V solenoid coil on reversing valve controls heating cycle operation. Two thermostat options, one allowing "Auto" changeover from cycle to cycle and the other constantly energizing solenoid coil during heating season and thus eliminating pressure equalization noise except during defrost, are to be used. On "Auto" option, a circuit is completed from R-W1 and R-Y on each heating "on" cycle, energizing reversing valve solenoid and pulling in compressor contactor starting compressor and outdoor motor. R-G also make starting indoor blower motor. Heat pump heating cycle is now in operation. The second option has no "Auto" changeover position, but instead energizes the reversing valve-solenoid constantly whenever the system switch on subbase is placed in "heat" position, the "B" terminal being constantly energized from R. A thermostat demand for heat completes R-Y circuit, pulling in compressor contactor starting compressor and outdoor motor. R-G also make starting indoor blower motor.

WALL THERMOSTAT AND SUBBASE COMBINATIONS			
Group	Thermostat	Subbase	Predominant Feature
A	8403-017 (T874R1129)	8404-009 (Q674L1181)	Heat or Cool <sup>①</sup> No Auto
B	8403-018 (T874N1024)	8404-010 (Q674F1261)	Automatic Heat-Cool Changeover Position <sup>②</sup>

① No automatic changeover position--must manually place in heat or cool. Reversing valve remains energized at all times system switch is in heat position (except during defrost cycle). No pressure equalization noise when thermostat is satisfied on either heating or cooling.

② Allows thermostat to control both heating and cooling operation when set in "AUTO" position. Reversing valve de-energizes at end of each "ON" heating cycle.

**IMPORTANT NOTE:** Both thermostat and subbase combinations shown above incorporate the following features: Man-Auto fan switch, Off-Heat-Cool-Em. Heat Switch, and two (2) indicator lamps--one for emergency heat and one for compressor malfunction.

### THERMOSTAT INDICATOR LAMPS

The red lamp marked "EM.HT." comes on and stays on whenever the system switch is placed in the emergency heat position. The green lamp marked "check" will come on if there is any problem that prevents the compressor from running when it is supposed to be.

### EMERGENCY HEAT POSITION

The operator of the equipment must manually place the system switch in this position. This is done when there is a known problem with the outdoor section, or when the green "check" lamp comes on indicating a problem.

### COMPRESSOR MALFUNCTION RELAY (1-Ph models only)

Actuation of the green "check" lamp is accomplished by a voltage type relay which is factory installed. Any condition such as loss of charge, defective capacitor, defective contactor, etc., that will prevent compressor from operating will cause green lamp to activate. This is a signal to the operator of the equipment to place system in emergency heat position.

## DEFROST CYCLE

The defrost cycle is controlled by time and temperature. The 24 volt timer motor runs all the time the compressor is in operation. When the outdoor temperature is in the lower 40°F temperature range or colder, the outdoor coil temperature is 32°F or below. This temperature is sensed by the defrost thermostat mounted near the bottom of the outdoor coil on a return bend. The defrost thermostat closes at approximately 32°F. Every 60 (or 30) minutes that the compressor is running, contacts 3-5 close for 7 minutes, with contacts 3-4 closed for the first 40 seconds of that 7 minutes. If the defrost thermostat is closed, the defrost relay energizes and places the system in defrost mode. An interlocking circuit is created with timer contacts 3-5 and defrost relay contacts 7-9 in series.

During the defrost mode, the refrigerant cycle switches back to the cooling cycle, the outdoor motor stops, electric heaters are energized, and hot gas passing through the outdoor coil melts any accumulated frost. When the temperature rises to approximately 57°F, the defrost thermostat opens, de-energizing the defrost relay and returning the system to heating operation.

If some abnormal or temporary condition such as a high wind causes the heat pump to have a prolonged defrost cycle, contacts 3-5 of the defrost timer will open after 7 minutes and restore the system to heating operations automatically.

There are two time settings on the defrost timer--30 minutes and 60 minutes. Most models are shipped wired on the 60 minute setting for greatest operating economy. If special circumstances require a change to the shorter time, remove wire connected to terminal 5/60 and reconnect to terminal 5/30. See next page.

There is a manual advance knob located on the timer. This can be used to advance timer to contact closure point if it is desired to check out defrost cycle operation without waiting for time to elapse.

### DEFROST TIMER WIRING

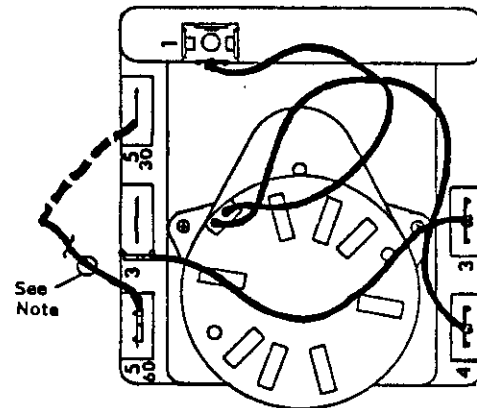

**NOTE:** All models are connected to 5/60 terminal (60 minute). Any model can be changed from 60 minutes to 30 minutes by unplugging from 5/60 terminal and reconnecting to 5/30 terminal as shown by dotted line.

## CRANKCASE HEATERS

All units are provided with some form of compressor crankcase heat. Some single phase units utilize the compressor motor start winding in series with a portion of the run capacitor to generate heat within the compressor shell to prevent liquid refrigerant migration.

Some three phase units utilize a wraparound type of crankcase heater that warms the compressor oil from the outside.

Some single and three phase models have an insertion well-type heater located in the lower section of the compressor housing. This is a self-regulating type heater that draws only enough power to maintain the compressor at a safe temperature.

Some form of crankcase heat is essential to prevent liquid refrigerant from migrating to the compressor, causing oil pump out on compressor start-up and possible valve failure due to compressing a liquid.

Refer to unit wiring diagram to find exact type of crankcase heater used.

The following decal is affixed to all outdoor units detailing start-up procedure. This is very important. Please read carefully.

**IMPORTANT**

THESE PROCEDURES MUST BE FOLLOWED AT INITIAL START-UP AND AT ANY TIME POWER HAS BEEN REMOVED FOR 12 HOURS OR LONGER.

TO PREVENT COMPRESSOR DAMAGE WHICH MAY RESULT FROM THE PRESENCE OF LIQUID REFRIGERANT IN THE COMPRESSOR CRANKCASE

1. MAKE CERTAIN THE ROOM THERMOSTAT IS IN THE OFF POSITION (THE COMPRESSOR IS NOT TO OPERATE).
2. APPLY POWER BY CLOSING THE SYSTEM DISCONNECT SWITCH THIS ENERGIZES THE COMPRESSOR HEATER WHICH EVAPORATES THE LIQUID REFRIGERANT IN THE CRANKCASE.
3. ALLOW 4 HOURS OR 60 MINUTES PER POUND OF REFRIGERANT IN THE SYSTEM AS NOTED ON THE UNIT RATING PLATE WHICHEVER IS GREATER.
4. AFTER PROPERLY ELAPSED TIME THE THERMOSTAT MAY BE SET TO OPERATE THE COMPRESSOR
5. EXCEPT AS REQUIRED FOR SAFETY WHILE SERVICING — DO NOT OPEN SYSTEM DISCONNECT SWITCH.

7981-081

## IMPORTANT INSTALLER NOTE

For improved start-up performance, wash the indoor coil with a dishwasher detergent.

## SERVICE HINTS

1. \*Caution homeowner to maintain clean air filters at all times. Also, not to needlessly close off supply and return air registers. This reduces air flow through the system, which shortens equipment service life as well as increasing operating costs.
2. Switching to heating cycle at 75°F or higher outside temperature may cause a nuisance trip of the manual reset high pressure switch.
3. The heat pump wall thermostats perform multiple functions. Be sure that all function switches are correctly set for the desired operating mode before trying to diagnose any reported service problems.
4. Check all power fuses or circuit breakers to be sure that they are the correct rating.
5. Periodic cleaning of the outdoor coil to permit full and unrestricted air flow circulation is essential.

## COMPRESSOR CUT-OFF THERMOSTAT AND OUTDOOR THERMOSTATS

Heat pump compressor operation at outdoor temperatures below 0°F are neither desirable nor advantageous in terms of efficiency. Since most equipment at time of manufacture is not designated for any specific destination of the country, and most of the equipment is installed in areas not approaching the lower outdoor temperature range, the compressor cut offs are not factory installed.

Outdoor thermostats are available to hold off various banks of electric heat until needed as determined by outdoor temperature. The set point of either type of thermostat is variable with geographic region and sizing of the heating equipment to the structure. Utilization of the Heating Application Data and the heat loss calculation of the building are useful in determining the correct set points.

## COMPRESSOR CUT-OFF & OUTDOOR THERMOSTAT WIRING

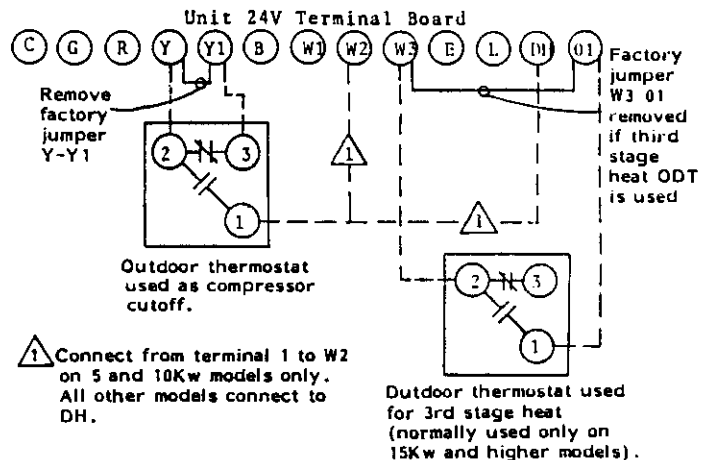

## 5-MINUTE COMPRESSOR TDR OPERATION

The time delay relay is a time delay device which will hold off the compressor contactor for a fixed time cycle of five minutes.

The application of such a device to an air conditioner or heat pump system is sometimes required because of repeated short-cycling of the equipment caused by "thermostat jiggling" or momentary power outages which occur quite frequently in some parts of the country due to weather conditions.

The time delay relay is a solid state device designed to allow the compressor contactor to operate on demand from the wall thermostat under normal conditions. As long as the "off" time of the air conditioner or heat pump system is longer than the delay period of the relay (five minutes), the compressor contactor will operate immediately. Once the contactor has been energized and then cycled off, for whatever reason, the relay will prevent the compressor contactor from operating until the nominal five minute period has elapsed.

## INSTALLATION

The time delay relay is mounted inside the control panel (refer to service parts section for mounting location). Disconnect the 24V wire (yellow) from the compressor contactor coil and reconnect to the TDR relay. Connect the yellow wire on the TDR relay to the compressor contactor coil (Figure 2.)

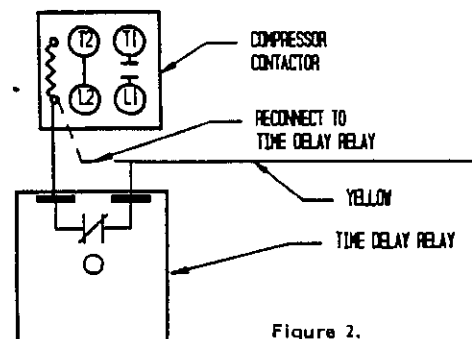
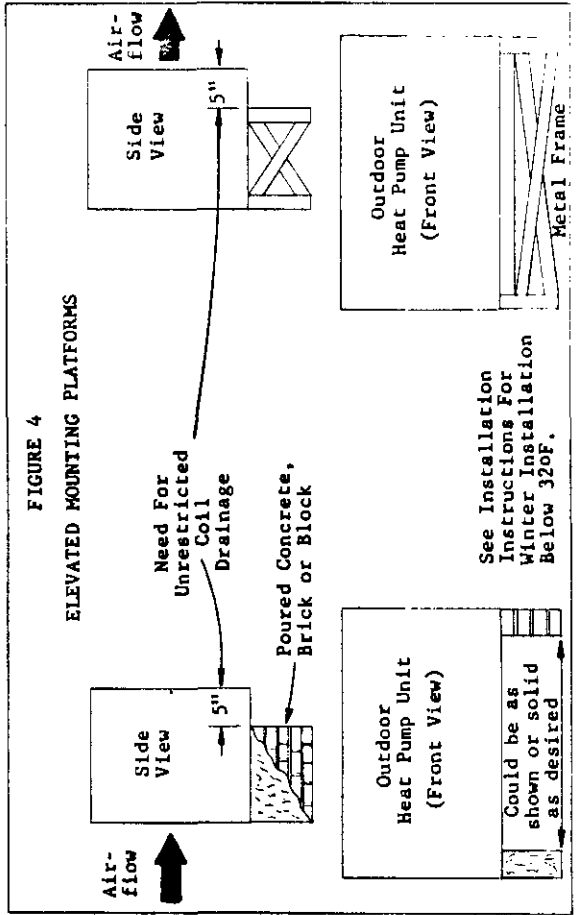
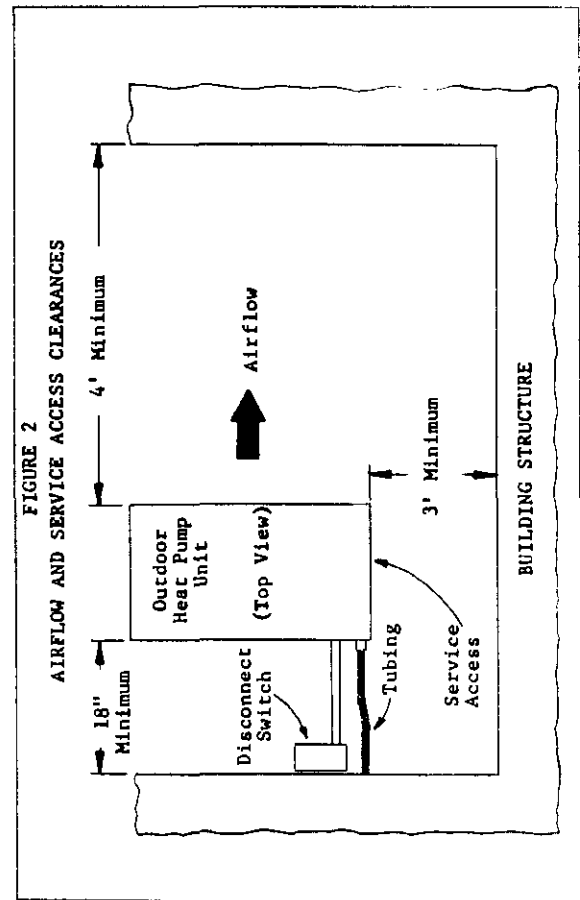
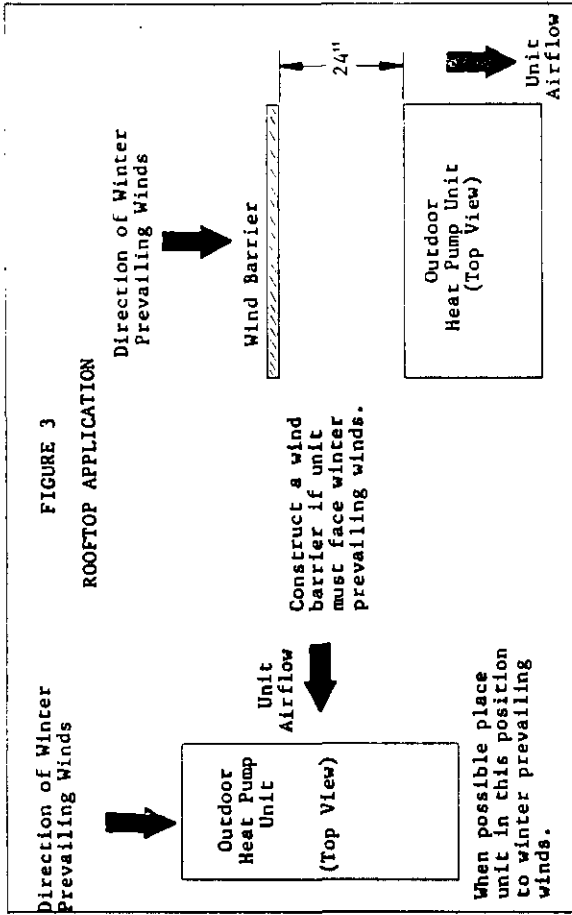
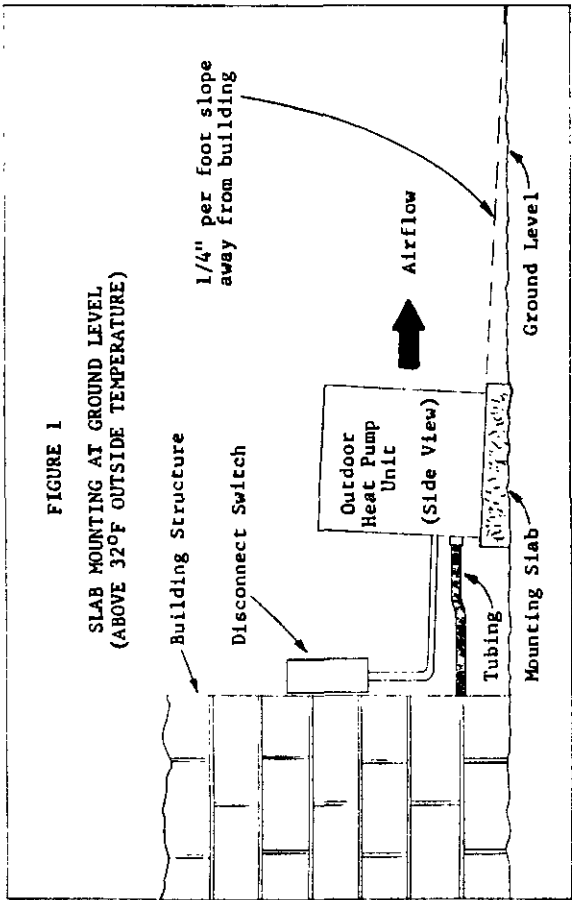

Figure 2.



## INSTALLING REFRIGERANT TUBING

**PRE-CHARGED TUBING** - Examine carefully the two lengths of pre-charged tubing furnished with the unit. The larger is the suction line. The smaller is the liquid line. The end of the tubing with the hex nut and gauge port is to be attached to the condensing unit.

Unroll the tubing, being careful not to kink, and install it between the condensing unit and the evaporator coil.

**CAUTION:** Be careful not to tear the insulation when pushing it through holes in masonry or frame walls.

When sealing tube opening in house wall use a soft material to prevent tube damage and vibration transmission.

Before fastening either end, use a tubing bender to make any necessary bends in the tubing. **AVOID EXCESSIVE BENDING IN ANY ONE PLACE TO AVOID KINKING.**

Start connecting the tubing at the evaporator coil end, first remove the protective caps and plugs from the quick-connect fittings on the evaporator coil and the pre-charged tubing. Inspect fittings and clean if necessary, making sure they are clear of foreign materials. If you clean the fittings, lubricate them with refrigeration oil. Connect both tubes to the fittings on the coil and draw up by hand.

When necessary to bend the insulated tube, suction line, cut the insulation around its circumference at a distance far enough beyond the point of the bend so as to clear the tubing bender.

Slip the insulation back together and vapor seal the joint with tape.

**NOTE:** The maximum distance for pre-charge tubing between the condenser and the evaporator is 45 feet.

**CAUTION:** Prior to connecting the pre-charged tubing to the evaporator coil or condensing unit, be sure all bends have been made, then coil any excess tubing in a horizontal plane, with the slope of the tubing toward the condensing unit.

**CAUTION:** Be sure to hold the coupling firmly to prevent movement of the coupling and tubing. Failure to do so could tear out the diaphragm causing a blockage of the system.

**CAUTION:** After starting to tighten up the fitting never try to back it off or take it apart.

For connecting the tubing at the condensing unit end, first remove the protective caps and plugs from the quick-connect fittings on the condensing unit and the pre-charged tubing. Inspect fittings and clean if necessary, making sure they are clear of foreign materials. If you clean the fittings, lubricate them with refrigeration oil. Connect both tubes to the fittings on the coil and draw up by hand.

Locate the gauge port in a 45° angle from a vertical up position so as to be accessible for gauge connections.

Use a wrench on the hex nut of the female fitting backing up the fitting with another wrench to keep tube from turning. Tighten the fittings together until they bottom out then tighten for an additional 1/4 turn so that coupling will seat properly.

Check the gauge port cap to make sure it is tight. If loose, tighten, being careful not to tighten too much as it will damage the valve in the gauge port.

Leak test all connections using an Electronic Leak Detector or a Halide Torch.

When tubing is installed in attics or drop ceiling, insulate the quick connect fitting on the larger tube thoroughly with 3/8" wall thickness, closed cell sponge tube insulation or equivalent. Failure to insulate will result in water damage to ceiling since the fitting will "sweat" and drop water on the ceiling.

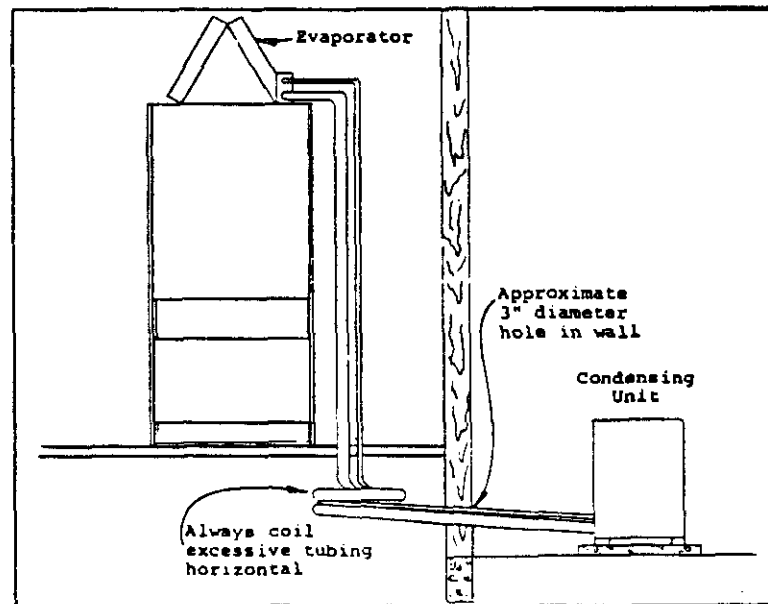

## R22 TOTAL SYSTEM CHARGE FOR SPLIT AIR CONDITIONING AND HEAT PUMP SYSTEMS

The following tables are used to determine the operating charge for split air conditioning and heat pump systems. The values shown are the total amount of refrigerant received in the precharged system components, which include the outdoor unit, indoor unit, and inter-connecting tubing. This is also the amount of refrigerant required for a system recharge following any refrigeration system repairs.

Find the outdoor section (and matching indoor section (Table A) and connecting tubing set (Table B) for system being used. Add the ounces of charge for each of the system components together. This value is the TOTAL SYSTEM CHARGE.

$$\begin{array}{ccccccc} \underline{\hspace{2cm}} & \text{OZs} & + & \underline{\hspace{2cm}} & \text{OZs} & + & \underline{\hspace{2cm}} & \text{OZs} & = & \underline{\hspace{2cm}} & \text{OZs} \\ \text{OUTDOOR UNIT} & & & \text{INDOOR UNIT} & & & \text{TUBING SET} & & & \text{TOTAL SYSTEM CHARGE} \\ \text{(Table A)} & & & \text{(Table A)} & & & \text{(Table B)} & & & & \end{array}$$

To change total charge to lbs. and Ozs., divide by 16.

EXAMPLE: 37ECQ1 with 3ACQ3 and GT35 tubing set.

$$\begin{array}{ccccccc} \underline{\hspace{2cm}} & \text{OZs} & + & \underline{\hspace{2cm}} & \text{OZs} & + & \underline{\hspace{2cm}} & \text{OZs} & = & \underline{\hspace{2cm}} & \text{OZs} \\ & & & & & & & & & & \\ \text{or } & \underline{\hspace{2cm}} & & & = & & 5 \text{ lbs. } & 2 \text{ oz.} & & & \end{array}$$

16

TABLE B CHARGED TUBING SETS FOR USE WITH 18ECQ2, 24ECQ4, 18HPQ5, 24HPQ5				
Model	Charge	Length in Ft.	Liquid Line	Suction Line
CT15	2 oz.	15	1/4"	5/8"
RW25	3 oz.	25	1/4"	5/8"
RW35	7 oz.	35	1/4"	5/8"
RW45	11 oz.	45	1/4"	5/8"
FOR USE WITH 30ECQ4, 31ECQ2, 36ECQ5, 37ECQ1, WQS30, WQS36, WQSD30, WQSD36				
CTO	None*	0	3/8"	3/4"
CT15	2 oz.	15	1/4"	5/8"
CT25	3 oz.	25	1/4"	3/4"
CT35	14 oz.	35	3/8"	3/4"
CT45	20 oz.	45	3/8"	3/4"
FOR USE WITH 30HPQ6, 36HPQ7				
CTO	None*	0	3/8"	3/4"
CT15A	2 oz.	15	3/8"	5/8"
CT25A	8 oz.	25	3/8"	3/4"
CT35A	14 oz.	35	3/8"	3/4"
CT45A	20 oz.	45	3/8"	3/4"
FOR USE WITH 42ECQ1, 48ECQ2, 60ECQ1, 42HPQ4, 48HPQ5, 60HPQ5, WQS50, WQSD50				
CTO-12	None*	0	3/8"	7/8"
CT15-12	2 oz.	15	3/8"	7/8"
CT25-12	8 oz.	25	3/8"	7/8"
CT35-12	14 oz.	35	3/8"	7/8"
CT45-12	20 oz.	45	3/8"	7/8"

\*CTO and CTO-12 for field installed tubing. (See Table C for charging).

TABLE A

Model	Outdoor Unit Factory Charge	For Use With Indoor Unit	Indoor Unit Factory Charge
18HPQ5	47 oz.	H18QS1 H24QS1 B18EHQ1 B24EHQ1	7 oz. 7 oz. 7 oz. 7 oz.
24HPQ5	53 oz.	H18QS1 H24QS1 B18EHQ1 B24EHQ1	7 oz. 7 oz. 7 oz. 7 oz.
30HPQ6	73 oz.	A36AQ-A <sup>1</sup> B30EHQ B36EHQ1	8 oz. 2 oz. 8 oz.
37HPQ7	88 oz.	A36AQ-A <sup>1</sup> B36EHQ1	8 oz. 8 oz.
42HPQ4	88 oz.	H4AQ1 BC48A	23 oz. 23 oz.
48HPQ5	122 oz.	H4AQ1 H5AQ1 BC48A BC60A	23 oz. 43 oz. 23 oz. 43 oz.
60HPQ5	112 oz.	H5AQ1 BC60A	43 oz. 43 oz.

<sup>1</sup> When using A36AQ-A with 30HPQ6 or 36HPQ7 total system charge must be increased by 8 oz.

In the event that the installer is running his own tubing by using a CTO kit or is modifying a precharged tubing set by adding or subtracting a few feet of tubing length, the tubing set should be evacuated and charged before being connected to the outdoor and indoor section. To determine TUBING SET ONLY charges, use the following table:

TABLE C (Shows Charge in Ozs.)												
	Tubing Set Length in Ft.	10	15	20	25	30	35	40	45	50	55	60
RW Series	1/4" O.D. Liquid Line	2	2	3	3	5	7	9	11	--	--	--
CT Series	3/8" O.D. Liquid Line	2	2	5	8	11	14	17	20	23	26	29

To determine a TOTAL SYSTEM CHARGE for a system that is connected with a non-standard tubing length, the outdoor basic charge (from Table A) plus the indoor unit basic charge (from Table A), is added to the tube set based on liquid line O.D. size (Table C). This value is the TOTAL SYSTEM CHARGE.

NOTE: If your tubing length is between the sizes shown in the table, use a charge value appropriately between the values shown for the tubing length shorter and longer than actual length.



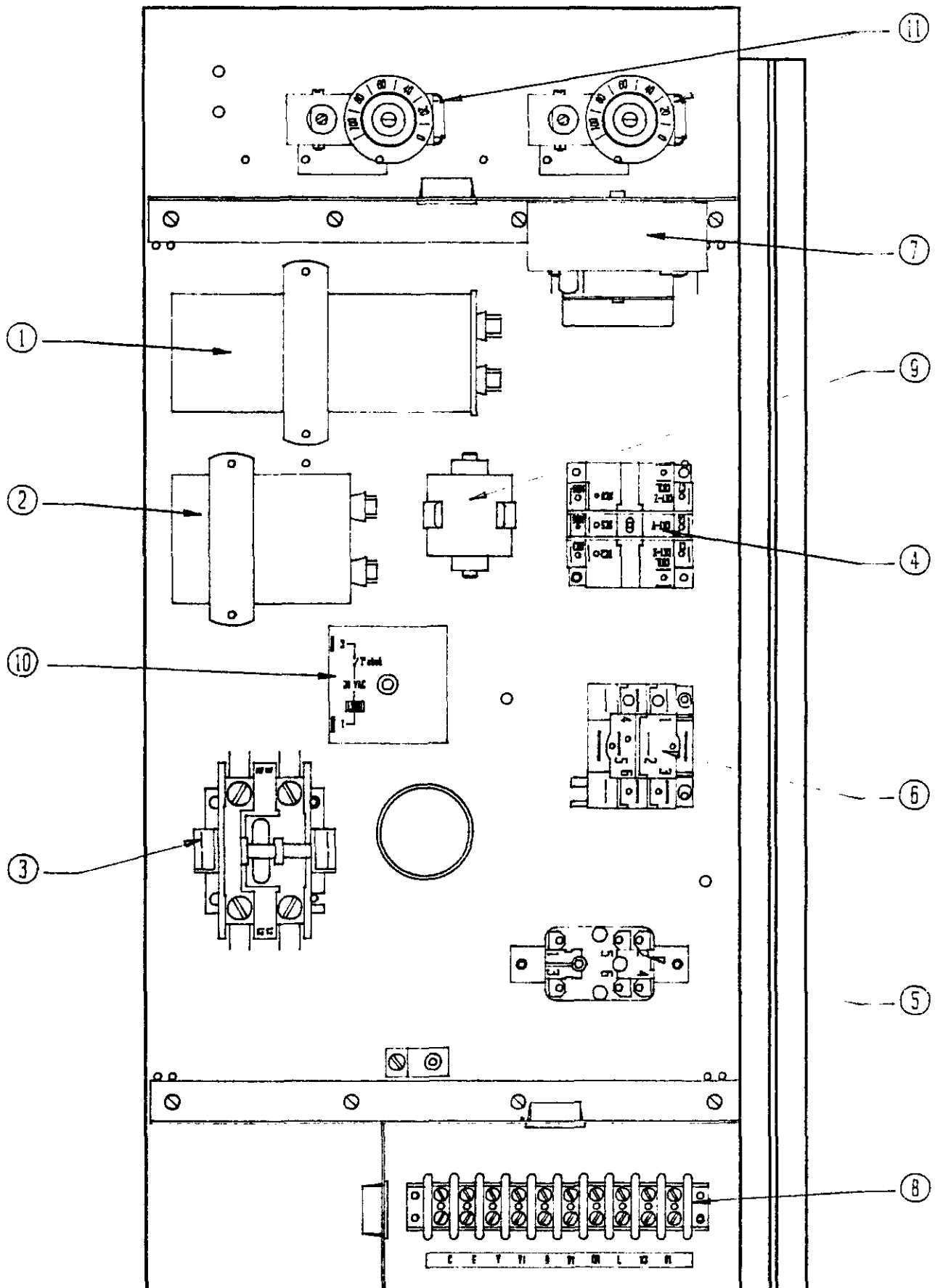

30-36 HPQ CONTROL PANEL

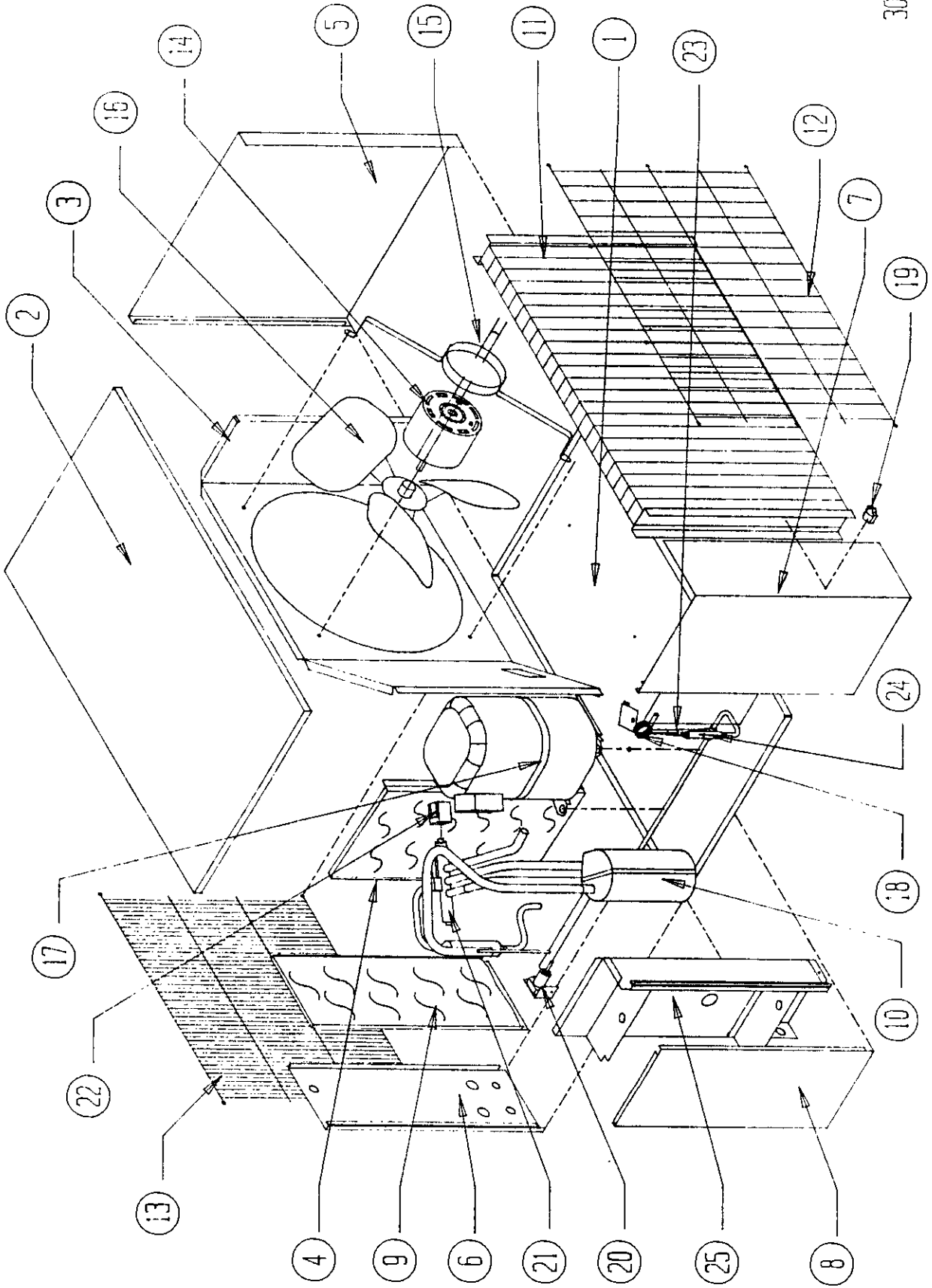

30-36 HFG

PARTS LIST  
SPLIT SYSTEM HEAT PUMPS

Item	Part No.	Description	30HPQ6	30HPQ6-B	30HPQ6-C	36HPQ7	36HPQ7-B	36HPQ7-C
BASIC UNIT PARTS LIST FIG. 1								
1	127-019	Base	x	x	x	x	x	x
2	507-018	Top	x	x	x	x	x	x
3	124-008	Fan Shroud	x	x	x	x	x	x
4	520-020	Compressor Partition	x	x	x	x	x	x
5	100-124	Side Right	x	x	x	x	x	x
6	148-032	Corner--Control Box	x	x	x	x	x	x
7	548-042	Corner--Condenser	x	x	x	x	x	x
8	132-021	Control Panel Control	x	x	x	x	x	x
9	552-017	Door--Compressor Access	x	x	x	x	x	x
10	5202-004	Accumulator	x	x	x			
10	5202-007	Accumulator				x	x	x
11	5051-003	Condenser Coil	x	x	x			
11	5051-053	Condenser Coil				x	x	x
12	7051-001	Condenser Grille	x	x	x	x	x	x
13	7051-003	Inlet Grille	x	x	x	x	x	x
14	8103-009	Motor--Fan 1/5	x	x		x	x	
14	8103-014	Motor--Fan 1/5 460V			x			x
15	8200-001	Motor Mount--Fan	x	x	x	x	x	x
16	5151-007	Fan Blade	x	x	x	x	x	x
17	8000-103	Compressor AW5532F	x					
17	8000-053	Compressor CRG3-0250-TF5		x				
17	8000-054	Compressor CRG3-0250-TFD			x			
17	8000-087	Compressor H23A383ABCA				x		
17	8000-088	Compressor AV145RT					x	
17	8000-089	Compressor AV145TT						x
	5811-020	Capillary Tube--Heat	1	1	1			
	5811-012	Capillary Tube--Heat				2	2	2
19	8408-017	Defrost Thermostat	x	x	x	x	x	x
20	8406-010	High Pressure Switch	x	x	x	x	x	x
21	5650-013	Reversing Valve	x	x	x			
21	5650-006	Reversing Valve				x	x	x
22	5650-008	Solenoid Coil	x	x	x	x	x	x
23	5651-036	Check Valve	x	x	x	x	x	x
24	5210-002	Strainer	x	x	x			
24	5210-004	Strainer				x	x	x
25	*	Control Panel	x	x	x	x	x	x
		*See Control Panel Drawing						

CONTROL PANEL PARTS LIST FIG. 2

1	8552-043	Capacitor 45/370V	x					
1	8552-028	Capacitor 35/440V				x		
2	8552-002	Capacitor 5/370	x	x	x	x	x	x
3	8401-007	Contact--Comp 25A	x			x		
3	8401-002	Contact--Comp 25A		x	x		x	x
4	8201-047	Relay--Defrost	x	x		x	x	
4	8201-032	Relay--Defrost			x			x
5	8201-015	Relay--Emergency Heat	x	x	x	x	x	x
6	8201-024	Relay--Compressor Fault	x			x		
7	8612-012	Defrost Timer	x	x	x	x	x	x
8	8607-011	Terminal Board	x	x	x	x	x	x
9	SK109	Low Voltage Start Kit	Field Inst.			Field Ins.		
10	CGAH-4	5 Min Time Delay				Field Installed		
11	8408-008	Outdoor Thermostat				Field Installed		
	4028-110	Wiring Diagram	x			x		
	4028-210	Wiring Diagram		x			x	
	4028-310	Wiring Diagram			x			x

AIR TEMPERATURE ENTERING OUTDOOR COIL DEGREE F.

Indoor Section	Return Air Temperature	Pressure	75	80	85	90	95	100	105	110	115
			B30EHQ Rated CFM 800	75° D.B. 62° W.B.	Low Side	62	63	65	66	68	70
		High Side	187	201	216	231	246	262	278	295	313
	80° D.B. 67° W.B.	Low Side	67	68	70	71	73	75	76	78	79
		High Side	191	206	221	237	253	269	286	303	321
	85° D.B. 72° W.B.	Low Side	72	73	75	76	78	80	81	83	85
		High Side	197	213	245	245	262	279	296	314	332
B36EHQ1 Rated CFM 1060	75° D.B. 62° W.B.	Low Side	67	68	70	71	73	74	76	77	78
		High Side	193	207	222	236	252	268	284	301	319
	80° D.B. 67° W.B.	Low Side	72	73	75	76	78	79	81	82	83
		High Side	199	213	228	243	259	275	292	309	327
	85° D.B. 72° W.B.	Low Side	77	79	81	82	84	85	87	88	89
		High Side	206	221	236	251	268	284	301	319	338
A36AQ-A Rated CFM 1130	75° D.B. 62° W.B.	Low Side	69	71	72	73	74	75	76	77	78
		High Side	199	213	228	243	258	274	291	308	326
	80° D.B. 67° W.B.	Low Side	74	76	77	78	79	80	81	83	84
		High Side	205	219	234	249	265	282	299	317	335
	85° D.B. 72° W.B.	Low Side	80	82	83	84	85	86	87	87	90
		High Side	213	227	242	258	274	291	309	328	347

HEATING

AIR TEMPERATURE ENTERING OUTDOOR COIL DEGREE F.

Indoor Section	Return Air Temp	Pressure	0	5	10	15	17	20	25	30	35	40	45	47	50	55	60
			B30EHQ Rated CFM 800	70° D.B.	Low Side	14	19	24	28	30	33	37	41	45	49	53	54
High Side	154	163			172	182	186	192	203	214	225	237	249	254	262	275	288
B36EHQ1 Rated CFM 1060	70° D.B.	Low Side	14	19	23	28	30	32	36	41	45	48	52	54	56	60	63
		High Side	135	145	155	165	169	175	185	195	205	215	225	229	235	245	255
A36AQ-A Rated CFM 1130	70° D.B.	Low Side	12	17	22	27	29	31	36	40	44	48	51	52	54	56	59
		High Side	136	145	155	164	168	173	183	191	200	208	217	220	225	233	240

Low side pressure + 2 PSIG (suction line between accumulator + compressor)  
 High side pressure +5 PSIG (liquid line @ outdoor unit quick connect)

Tables are based upon rated CFM (airflow) across the evaporator coil and should be found under section titled "Refrigerant Charge" elsewhere in manual. If there is any doubt as to correct operating charge being in the system, the charge should be removed, system evacuated, and recharged to serial plate instructions.

36HPQ7

## COOLING

AIR TEMPERATURE ENTERING OUTDOOR COIL DEGREE F.

Indoor Section	Return Air Temperature	Pressure	75	80	85	90	95	100	105	110	115
			B36EQ1 Rated CFM 1240	75° D.B. 62° W.B.	Low Side	61	63	65	67	68	69
High Side	202	217			233	249	265	281	297	313	330
80° D.B. 67° W.B.	Low Side	65		67	69	71	73	74	76	77	78
	High Side	208		223	239	255	272	288	305	321	339
85° D.B. 72° W.B.	Low Side	70		72	74	76	78	80	81	82	84
	High Side	215		231	247	264	281	300	315	332	350
A36AQ-A Rated CFM 1200	75° D.B. 62° W.B.	Low Side	65	66	68	70	71	73	74	75	76
		High Side	217	231	246	261	277	293	310	327	344
	80° D.B. 67° W.B.	Low Side	70	71	73	75	76	77	79	80	81
		High Side	222	237	252	268	284	301	318	335	353
	85° D.B. 72° W.B.	Low Side	74	76	78	80	82	84	85	86	87
		High Side	229	245	261	277	294	311	329	347	365

## HEATING

AIR TEMPERATURE ENTERING OUTDOOR COIL DEGREE F.

Indoor Section	Return Air Temp	Pressure	0	5	10	15	17	20	25	30	35	40	45	47	50	55	60
			B36EQ1 Rated CFM 1240	70° D.B.	Low Side	20	22	25	27	29	31	34	38	42	46	51	53
High Side	145	154			163	173	178	184	195	207	219	231	244	250	258	272	286
A36AQ-A Rated CFM 1200	70° D.B.	Low Side	17	20	24	28	29	31	35	39	43	47	51	53	56	60	64
		High Side	133	145	157	169	174	181	193	204	215	226	237	241	247	258	268

Low side pressure  $\pm$  2 PSIG (suction line between accumulator + compressor)  
 High side pressure  $\pm$  5 PSIG (liquid line @ outdoor unit quick connect)

Tables are based upon rated CFM (airflow) across the evaporator coil and should be found under section titled "Refrigerant Charge" elsewhere in manual. If there is any doubt as to correct operating charge being in the system, the charge should be removed, system evacuated, and recharged to serial plate instructions.

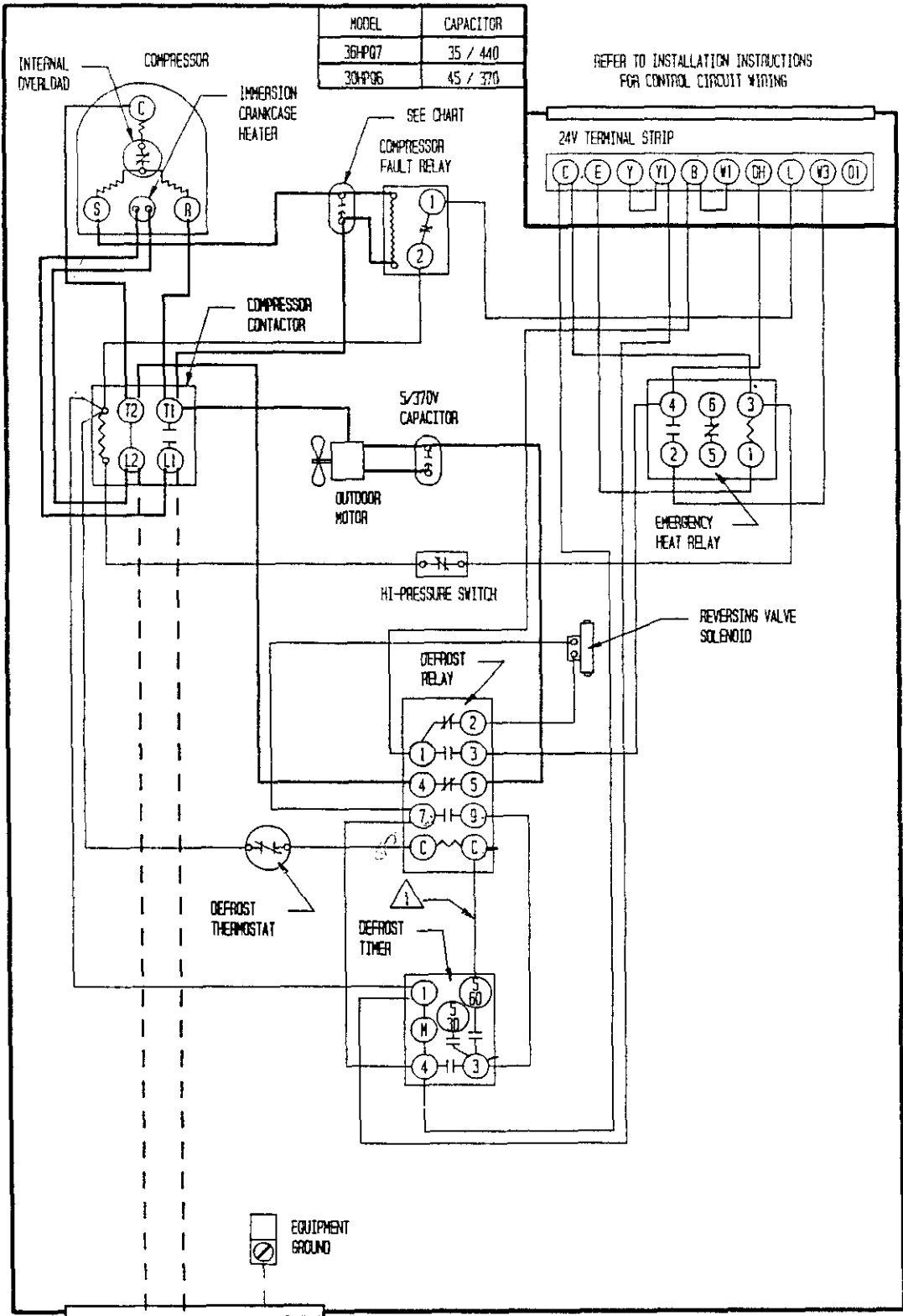

MODEL	CAPACITOR
36HP07	35 / 440
30HP06	45 / 370

REFER TO INSTALLATION INSTRUCTIONS FOR CONTROL CIRCUIT WIRING

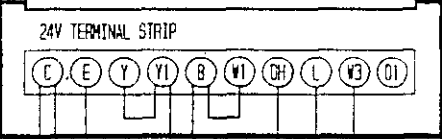

USE COPPER CONDUCTORS ONLY

⚠ RECONNECT FROM 5-60 TO 5-30 FOR 30 MINUTE CYCLE

	FACTORY WIRING	FIELD WIRING
Low Voltage	—————	- - - - -
High Voltage	—————	- - - - -

FUSED DISCONNECT SWITCH

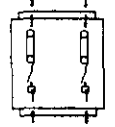

EQUIPMENT GROUND





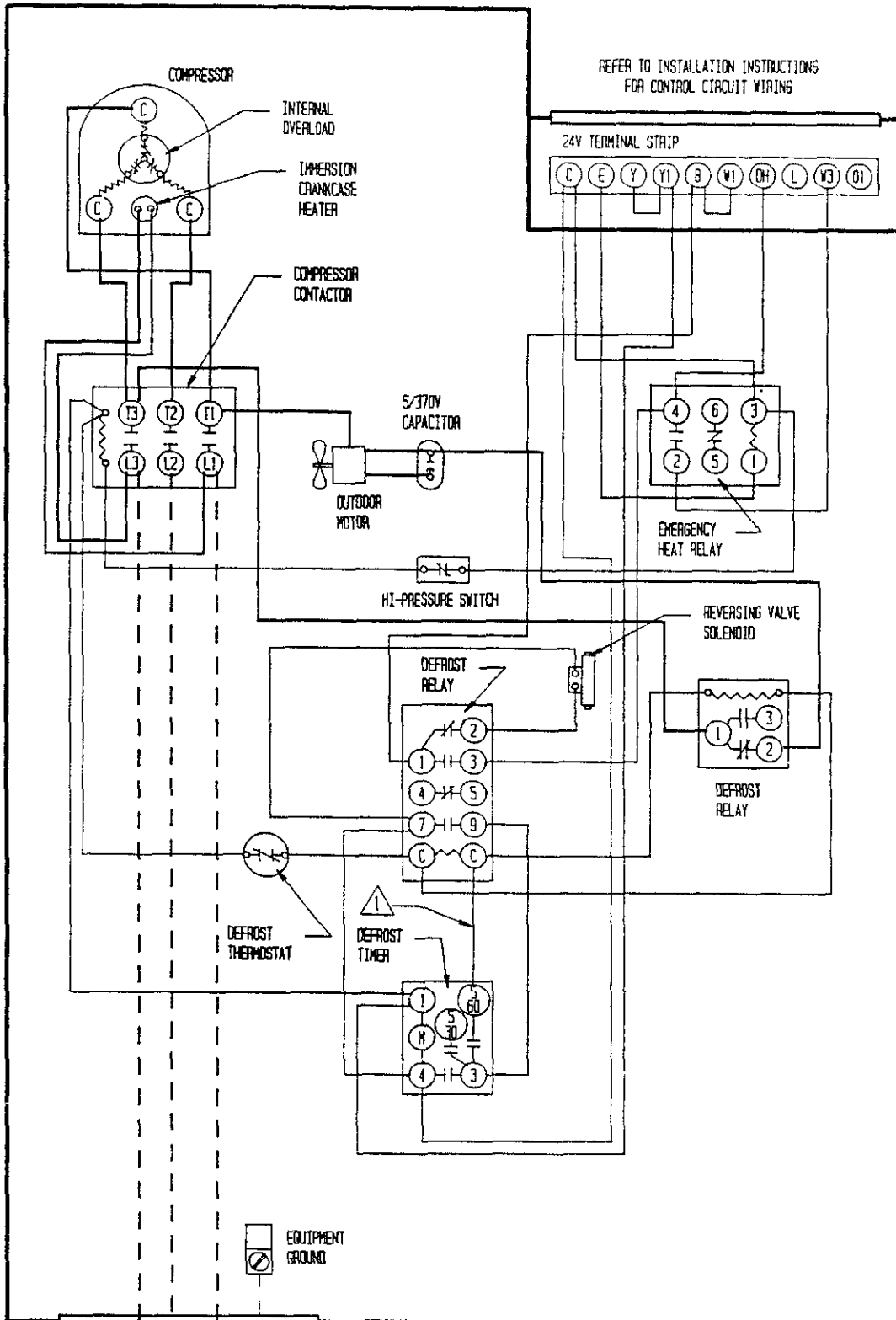

FUSED DISCONNECT SWITCH

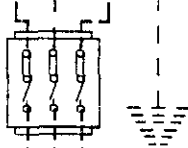

450 - 50 - 3

USE COPPER CONDUCTORS ONLY

	FACTORY WIRING	FIELD WIRING
Low Voltage	—————	- - - - -
High Voltage	—————	—————

⚠ RECONNECT FROM 5-60 TO 5-30 FOR 30 MINUTE CYCLE