

THE WALL MOUNT tm HI-BOY COMBINATION GAS/ELECTRIC USER'S INFORMATION MANUAL

WARNING: If the information in this manual is not followed exactly, a fire or explosion may result causing property damage, personal injury or loss of life.

- Do not store or use gasoline or other flammable vapors and liquids in the vicinity of this or any other appliance.

- **WHAT TO DO IF YOU SMELL GAS**
 - Do not try to light any appliance.
 - Do not touch any electrical switch; do not use any phone in your building.
 - Immediately call your gas supplier from a neighbor's phone. Follow the gas supplier's instructions.
 - If you cannot reach your gas supplier, call the fire department.

- Installation and service must be performed by a qualified installer, service agency or the gas supplier.

MANUAL 2100-148 REV. E
SUPERSEDES REV. D
FILE VOL. III, TAB 20

TABLE OF CONTENTS

General	1
Clearances	1
Notice: Be Sure To Observe The Following Rules	1
Combustion and Ventilating Air	1
Lighting and Shutdown Instructions	1
Air Filters	4
Air Conditioning Start Up Procedure Crankcase Heaters	4
CIRCULATING BLOWER CONTROL	5
Initial Start Up	5
Heating Operation	5
Cooling Operation	5
Maintenance Instructions	5
Routine Maintenance	5
Routine Inspection	5
Replacement Parts	6
Venting Troubleshooting Procedures	7
Fresh Air Damper Assembly	7
Filter	7

COPYRIGHT FEBRUARY, 1989
BARD MANUFACTURING COMPANY
BRYAN, OHIO 43506 U.S.A.

GENERAL

The warnings shown on the cover of this manual and the information on the following pages are very important and should be fully read and understood by the operator of this equipment. Please take the few minutes necessary to completely read this booklet, and if there are any questions when you are through, ask your installer to review them with you. Please retain this booklet for future reference.

CLEARANCES

There are certain minimum installation clearances from the unit cabinet and sheet metal plenum attached to the unit to any combustible materials. These clearances for each model are shown on the unit rating plate (located on the right side) and are the responsibility of the installer during the installation of the appliance.

It is the user's responsibility to make sure these clearances are always maintained thereafter. Additionally, a minimum of 30 inches for serviceability is required from the right side of all models.

NOTICE: BE SURE TO OBSERVE THE FOLLOWING RULES:
--

- A. **DO NOT** allow any cardboard, newspapers, or any other combustible material (this includes wood, 2x4's, etc.) within the above specified minimum clearances. This includes placing any combustibles on or against the sheet metal plenum attached to the unit.
- B. **DO NOT** use this unit if any part has been under water. Immediately call a qualified service technician to inspect the unit and to replace any part of the control system and any gas control which has been under water.
- C. The equipment is to be kept clear and free of combustible materials, solvents, painting supplies, and any other flammable vapors or liquids.

COMBUSTION AND VENTILATING AIR

It is the responsibility of the user to assure that the important flow of combustion and ventilating air is not obstructed from reaching the unit.

Do not block or obstruct air openings on the unit.

LIGHTING AND SHUTDOWN INSTRUCTIONS

Refer to Figure 3 for general location of components referenced in the following "Lighting and Shutdown Instructions." These components are located behind the "Burner Access Door".

IMPORTANT
Should overheating occur, or the gas supply fail to shut off, shut off the manual gas valve to the unit before shutting off the electrical supply.

FIGURE 1

FOR YOUR SAFETY READ BEFORE OPERATING



WARNING: If you do not follow these instructions exactly, a fire or explosion may result causing property damage, personal injury or loss of life.

- A. This appliance is equipped with an ignition device which automatically lights the pilot. Do not try to light the pilot by hand.
- B. BEFORE OPERATING smell all around the appliance area for gas. Be sure to smell next to the floor because some gas is heavier than air and will settle on the floor.
- WHAT TO DO IF YOU SMELL GAS**
- Do not try to light any appliance.
 - Do not touch any electric switch; do not use any phone in your building.
 - Immediately call your gas supplier from a neighbor's phone. Follow the gas supplier's instructions.
- C. Use only your hand to push in or turn the gas control knob. Never use tools. If the knob will not push in or turn by hand, don't try to repair it, call a qualified service technician. Force or attempted repair may result in a fire or explosion.
- D. Do not use this appliance if any part has been under water. Immediately call a qualified service technician to inspect the appliance and to replace any part of the control system and any gas control which has been under water.
- If you cannot reach your gas supplier, call the fire department.

OPERATING INSTRUCTIONS

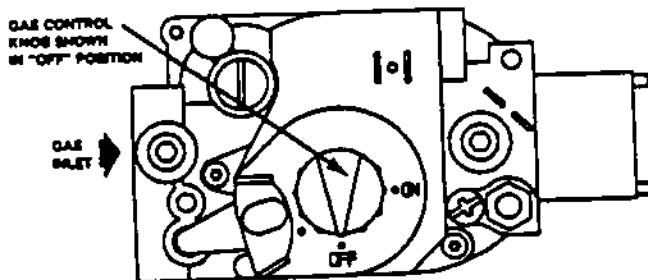
1. STOP! Read the safety information above on this label.
2. Set the thermostat to lowest setting.
3. Turn off all electric power to the appliance.
4. This appliance is equipped with an ignition device which automatically lights the pilot. Do not try to light the pilot by hand.



5. Remove control access panel.
6. Push in gas control knob slightly and turn clockwise  to "OFF".
NOTE: Knob cannot be turned to "OFF" unless knob is pushed in slightly. Do not force.
7. Wait five (5) minutes to clear out any gas. Then smell for gas, including near the floor. If you smell gas, STOP! Follow "B" in the safety information above on this label. If you don't smell gas, go to the next step.
8. Turn gas control knob counterclockwise  to "ON".
9. Replace control access panel.
10. Turn on all electric power to the appliance.
11. Set thermostat to desired setting.
12. If the appliance will not operate, follow the instructions "To Turn Off Gas To Appliance" and call your service technician or gas supplier.

TO TURN OFF GAS TO APPLIANCE

1. Set the thermostat to lowest setting.
2. Turn off all electric power to the appliance if service is to be performed.
3. Remove control access panel.
4. Push in gas control knob slightly and turn clockwise  to "OFF". Do not force.
5. Replace control access panel.

7961-389

Figure 2

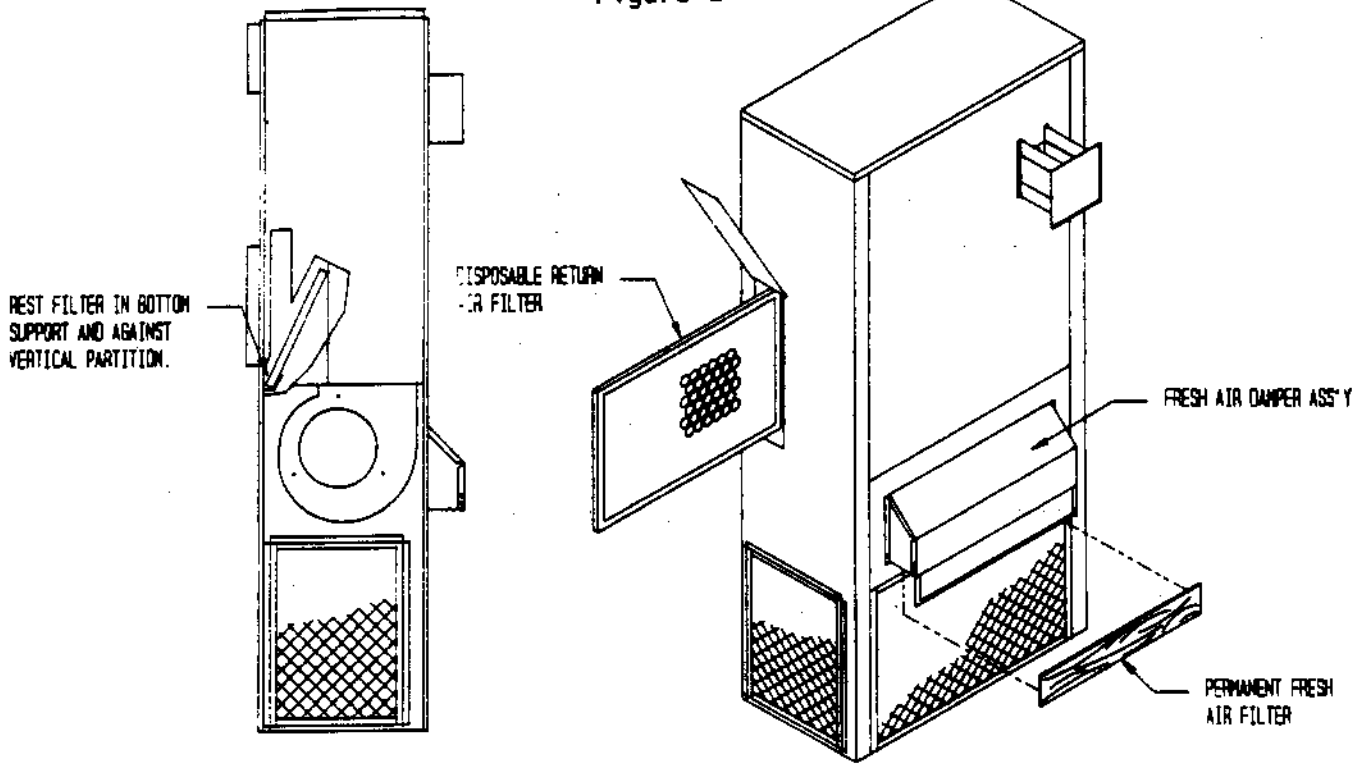
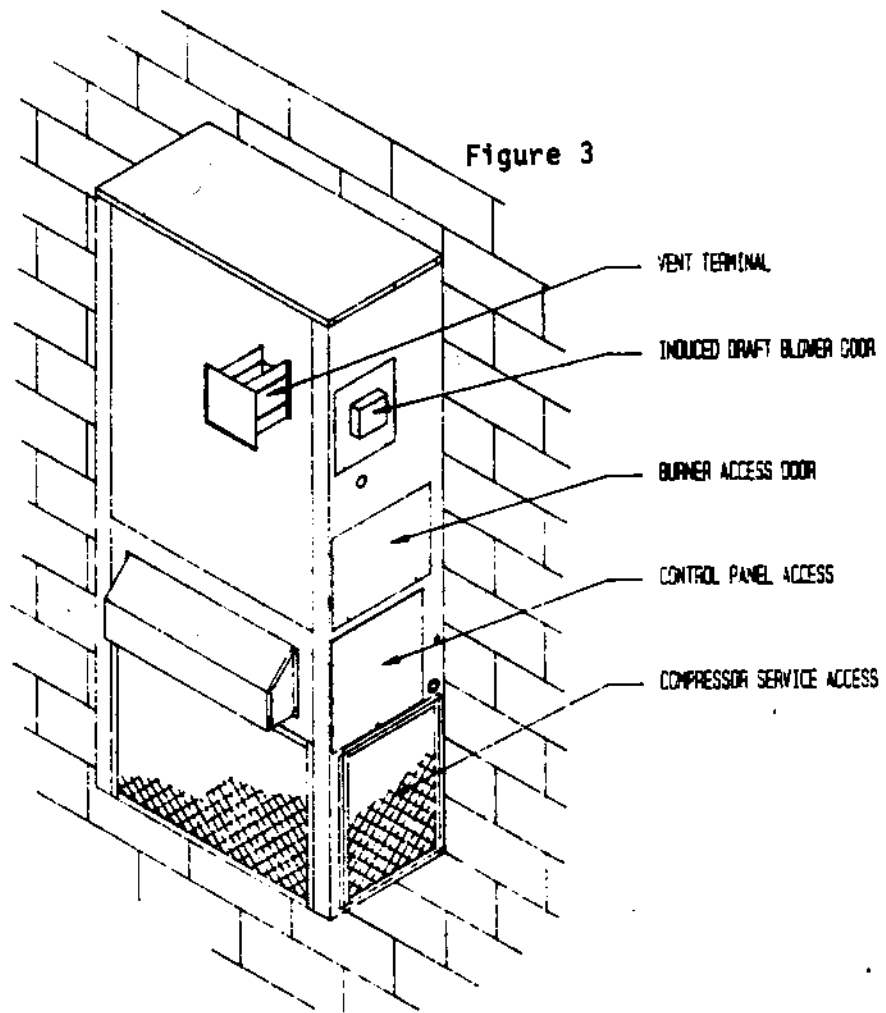

Figure 3



AIR FILTERS

It is the user's responsibility to check the condition of the air filters on at least a monthly basis when the unit is in use and to clean or replace whenever it is necessary.

Permanent Type Filter (usually foam type) are washable. Use a solution of soapy water, followed by a rinse in clear water and then dried by tapping the frame against a solid object.

NEVER OPERATE THE UNIT WITHOUT PROPER FILTERS IN PLACE

NEVER SUBSTITUTE A THROWAWAY (FIBERGLASS) FOR A PERMANENT (FOAM) TYPE

Return air filter size is 20 x 30 x 1 (throwaway) and is serviceable from the left side of the unit as shown in Figure 2.

Fresh air filter size is 4 x 26 x 1/2 and is a permanent type filter, refer to Figure 2 for service location.

AIR CONDITIONING START UP PROCEDURE CRANKCASE HEATERS

Single and three phase models have an insertion well-type heater located in the lower section of the compressor housing. This is a self-regulating type heater that draws only enough power to maintain the compressor at a safe temperature.

Some form of crankcase heat is essential to prevent liquid refrigerant from migrating to the compressor, causing oil pump out on compressor start-up and possible valve failure due to compressing a liquid.

The decal in Figure 4 is affixed to all outdoor units detailing start-up procedures. This is very important. Please read carefully.

FIGURE 4

IMPORTANT

THESE PROCEDURES MUST BE FOLLOWED AT INITIAL START-UP AND AT ANY TIME POWER HAS BEEN REMOVED FOR 12 HOURS OR LONGER.

TO PREVENT COMPRESSOR DAMAGE WHICH MAY RESULT FROM THE PRESENCE OF LIQUID REFRIGERANT IN THE COMPRESSOR CRANKCASE:

1. MAKE CERTAIN THE ROOM THERMOSTAT IS IN THE "OFF" POSITION. (THE COMPRESSOR IS NOT TO OPERATE).
2. APPLY POWER BY CLOSING THE SYSTEM DISCONNECT SWITCH. THIS ENERGIZES THE COMPRESSOR HEATER WHICH EVAPORATES THE LIQUID REFRIGERANT IN THE CRANKCASE.
3. ALLOW 4 HOURS OR 60 MINUTES PER POUND OF REFRIGERANT IN THE SYSTEM AS NOTED ON THE UNIT RATING PLATE, WHICHEVER IS GREATER.
4. AFTER PROPERLY ELAPSED TIME THE THERMOSTAT MAY BE SET TO OPERATE THE COMPRESSOR.
5. EXCEPT AS REQUIRED FOR SAFETY WHILE SERVICING — DO NOT OPEN SYSTEM DISCONNECT SWITCH.

7961-061

CIRCULATING BLOWER CONTROL

INITIAL START UP

When electrical power is first supplied to the unit, the low speed blower relay will automatically energize and the indoor motor will run for one minute. This run in period will only occur during initial power up or when the power supply is interrupted.

HEATING OPERATION

One minute after main burner ignition the circulating blower will start on low speed. Following termination of the heating cycle a two minute delay will keep the circulating blower running. Any major deviations from these times should be reported to your service agency.

COOLING OPERATION

Immediately upon a call for cooling the circulating blower will be energized on high speed. At the end of the cooling cycle, the compressor will stop and the circulating blower will continue to run for one minute.

MAINTENANCE INSTRUCTIONS

The unit should be inspected annually by a qualified service agency.

Routine inspection and maintenance procedures are the responsibility of the owner/user and are outlined below.

ROUTINE MAINTENANCE

1. Air Filters. Check the condition at least monthly when the unit is in use, and replace (throwaway, fiberglass type) or clean (permanent, foam type) as necessary. Reference Figure 2.
2. Lubrication Requirements. The indoor circulating air blower motor and outdoor circulating air fan motor are permanently lubricated and require no re-oiling. The combustion air blower motor should be re-oiled once a year with 3-4 drops SAE20 motor oil. **WARNING**--Turn off electrical power supply to prevent injury from moving parts or electric shock.

ROUTINE INSPECTION

1. Inspect the physical support of the unit annually to make sure it is securely fastened to the building. Also look for any obvious signs of deterioration.
2. Inspect the pilot and main burner adjustment at the beginning of each heating season. Refer to Figures 5 and Figure 6 for general guidelines. Call qualified service agency for any adjustments.
3. Inspect the vent terminal for any obvious deterioration, and to make sure it is free and clear of any obstructions.

REPLACEMENT PARTS

Replacement parts for the gas/electric units are available through local distributors.

A replacement parts list manual is supplied with each unit. When ordering parts or making inquiries pertaining to any of the units covered by these instructions, it is very important to always supply the COMPLETE model number and serial number of the unit. This is necessary to assure that the correct parts (or an approved alternate part) are issued to the service agency.

FIGURE 5

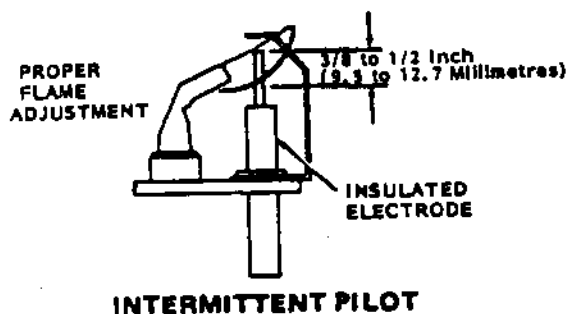
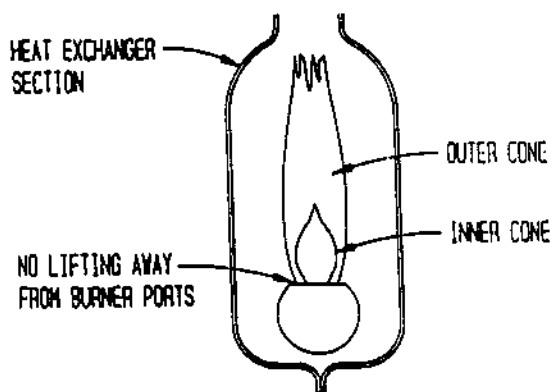

FIGURE 6



Observe the main burners in operation. The flame should be mostly "blue" with possibly a little orange (not yellow) at the tips of the flames. The flames should be in the center of the heat exchanger compartments and not impinging on the heat exchanger surfaces themselves.

Observe the fire until the blower starts (there is a normal delay period until the heat exchanger warms up). There should be no change in the size or shape of the flame. If there is any wavering or blowing of the flame on blower start-up, it is an indication of a possible leak in the heat exchanger.

VENTING TROUBLESHOOTING PROCEDURES

TABLE 1

Symptoms	Possible Causes	How To Check And/Or Correct
Downdrafting through the furnace	Negative pressure within the structure caused by exhaust fan of device	Check for downdraft in vent where vent connects to unit with flame from a candle or a match, or smoke from a cigarette, cigar, or pipe.
	Location of vent terminal	Verify that vent termination is positioned with the recommended specifications stated in this manual.
	Incorrect or absent vent terminal	Verify that the vent terminal is designed for and is compatible with the venting system.
Condensation in venting system	Oversized venting system	Look for condensation in or around vent pipe joints or around flue connections at furnace. To correct this condition, design the venting system in accordance with the National Fuel Gas Code, ANSI-Z223.1-latest edition and addenda Z223.1a latest edition
	Uninsulated vent installed in an unconditioned space	Check for condensation in or around vent pipe joints. Also check around the flue connecting areas on the unit. Insulate the vent in unconditioned space to prevent the above condition.
	Running vent as a liner up an existing chimney without capping off the chimney	Check to make sure the space between the vent and the inside of the chimney has been sealed. With this space being open, it may allow too much cold air in and around the vent pipe allowing the flue products to condense causing condensation back at the unit.

FRESH AIR DAMPER ASSEMBLY

The fresh air damper assembly is shipped in the return air chamber accessed from the back of the unit. Remove the shipping screws and damper assembly. Attach the damper assembly to the blower service door as shown in Figure 2. The damper assembly includes a permanent filter that can be easily removed for cleaning (Figure 3).

The damper blade is shipped in the full open position allowing the maximum amount of fresh air at all times. If no fresh air is desired or if barometric operation (blade opens when blower starts) is desired, remove and reinsert the plastic canoe clips as shown in Figure 7.

All capacity, efficiency and cost of operation information as required for Department of Energy "Energyguide" Fact Sheets is based upon the fresh air blank-off plate (BOP-1) in place and is recommended for maximum energy efficiency. The blank-off plate is available upon request from the factory and is installed in place of the fresh air damper shipped with each unit.

FILTER

A one inch throw away filter is supplied with each unit taped to the back of the unit. This filter is installed by removing the filter service door located on the left side and sliding the filter into position, as shown in Figure 3.

FIGURE 7

