

INSTALLATION INSTRUCTIONS

MODELS:

CH060D36B

CH080D48B

CH100D60B

CC060D36A

CC080D48A

CC100D48A

**UPFLOW & DOWNFLOW CONDENSING
GAS FURNACES**

COPYRIGHT FEBRUARY, 1989
BARD MANUFACTURING COMPANY
BRYAN, OHIO

INDEX

I. Application 1

II. High Altitude Application 1

III. Locating the Furnace. 1

IV. Duct Work 2

V. Combustion and Ventilation Air 3

VI. Venting 3

 1. General Instructions 4

 2. Types of Insulation 5

 3. Connecting Vent To Furnace 5

 4. Joining Pipe and Fittings 6

 A. PVC Cleaner--Primer and PVC Medium Body Solvent Cement. 6

 5. Horizontal Vents 7

 6. Vent Location 7

 7. Location Requirements 7

 8. Vent Termination 10

VII. Combustion Air Intake 10

VIII. Condensate Drain/Neutralizer. 11

IX. Gas Supply and Piping 12

 A. General Recommendations 12

 B. Checking The Gas Piping 13

X. Wiring 13

 A. Electrical Power Supply 13

 B. Electrical Grounding 14

XI. Thermostat 14

XII. Blower Operation 14

 A. Field Installed Equipment 14

XIII. Filters 14

 A. Filter Locations--Removal and Replacement Procedures--
 All Hi-Boy Furnaces 15

 B. Alternate Bottom Filter Location 16

 C. Five Ton Cooling Capacity 16

 D. Filter Locations--Counterflow Models 16A

XIV. Sequence Of Operation 18

XV. Maintenance Instructions 18

XVI. Service Agency Procedures 18

 A. Heat Exchangers and Flue Gas Passageways 19

XVII. Replacement Parts 20

INDEX OF FIGURES AND TABLES

Figure 1	8
Figure 2	8
Figure 3	8
Figure 4	9
Figure 5	9
Figure 6	9
Figure 7	12
Figure 8	11A
Figure 9	15
Figure 10	16
Figure 10A	16A
Figure 10B	16A
Figure 11	18
Figure 12	19
Table 1	1
Table 2	2
Table 3	4
Table 4	13
Table 5	13
Table 6	15

APPLICATION

This is a forced air gas furnace for indoor installation in building constructed on site. The furnace installation must conform with local building codes and ordinances or, in their absence with the National Fuel Gas Code, ANSI Z223.1-latest edition, and the National Electrical Code, ANSI/NFPA 70-latest edition. It is the personal responsibility and obligation of the purchaser to contract a qualified installer to assure that installation is adequate and is in conformance with governing codes and ordinances.

HIGH ALTITUDE APPLICATION

Rating of gas utilization equipment are based on sea level operation and need not be changed for operation at elevations up to 2,000 feet. For operation at elevations above 2,000 feet and, in the absence of specific recommendations from the local authority having jurisdiction, equipment ratings shall be reduced at the rate of 4 percent for each 1,000 feet above sea level before selecting appropriately sized equipment. (Ref. ANSI Z223.1-latest edition, Par. 8.12). See Table 1.

TABLE 1
EQUIVALENT ORIFICE SIZES AT HIGH ALTITUDES
(Includes 4% Input Reduction For Each 1,000 Feet)

Orifice Size At Sea Level	Orifice Size Required At Other Elevations								
	2000	3000	4000	5000	6000	7000	8000	9000	10,000
38	39	40	41	41	42	42	43	43	44
41	42	42	42	43	43	44	44	45	46
42	42	43	43	43	44	44	45	46	47
53	54	54	54	54	54	54	55	55	55
54									

LOCATING THE FURNACE

When selecting a location for the furnace, observe the following rules.

1. The furnace should be set on a level floor. If the floor may become damp or wet at times, the furnace should be supported above the floor using a concrete base, bricks, patio blocks, etc., making sure adequate support is available for the furnace. Counterflow furnaces require the use of combustible floor base if installed on combustible surface. The combustible floor base is not part of the furnace and must be ordered separately. Furnace approved for installation on combustible flooring shall not be installed directly on carpeting, tile or other combustible material other than wood flooring.
2. The furnace should be as centralized as practical with respect to the air distribution system.
3. The vent pipe should be as short as practical but must be at least 3 feet and no more than 60 feet in total equivalent length to vent combustion products outdoors, (see Venting).
4. Provide at least the minimum clearances specified in Table 2 for fire protection, proper operation and service access. These clearances must be permanently maintained. The ventilating air openings in the front of the furnace must never be obstructed.
5. Fresh air for combustion must be piped from the outside to the connection on either the right or left side of the furnace (see Combustion Air).
6. Minimum service clearances must take precedence over fire protection clearances (minimum installation clearances).

7. All models are approved for a utility room or closet installation.
8. A gas-fired furnace installed in a residential garage must be installed so that the burners and ignition source are located not less than 18 inches above the floor, and the furnace must be located or protected to avoid physical damage by vehicles.

CAUTION

DO NOT locate furnace where temperature may drop below freezing as condensate may freeze resulting in improper operation or furnace damage.

CAUTION

Do not store combustible materials near furnace or warm air ducts. The material may ignite by spontaneous combustion creating a fire hazard.

**TABLE 2
MINIMUM CLEARANCES (INCHES)**

Model	Minimum Installation Clearances						Min Service Clearances			
	Top	Front	Back	Right Side	Left Side	*Floor	Front	Back	Left Side	Right Side
CB060	1	6	0	0	0	C	24	0	0	0
CB080	1	6	0	0	0	C	24	0	0	0
CB100	1	6	0	0	0	C	24	0	0	0
CC060	1	6	0	0	0	NC	24	0	0	0
CC080	1	6	0	0	0	NC	24	0	0	0
CC100	1	6	0	1	0	NC	24	0	0	1

*C--Floor may be combustible material. Refer to "Locating The Furnace" page 1, item 1.
 NC--Floor must be non-combustible. Can be installed on combustible flooring only when installed on special base part No. CFB-6 (CC060), CFB-7 (CC080), CFB-8 (CC100).

DUCT WORK

The air distribution system should be designed and installed in conformance with Manuals 7 or 7A published by Air Conditioning Contractors of America (ACCA), as set forth in their Manual K.

CAUTION

When a furnace is installed so that supply ducts carry air circulated by the furnace to areas outside the space containing the furnace, the return air must also be handled by a duct(s) sealed to the furnace casing and terminating outside the space containing the furnace. This is to prevent drawing possible hazardous combustion products into the circulated air.

When the furnace is used in connection with a cooling unit*, the furnace shall be installed parallel with or on the upstream side of the cooling unit to avoid condensation in the heating element. With a parallel flow arrangement, the dampers or other means used to control flow of air shall be adequate to prevent chilled air from entering the furnace and, if manually operated, must be equipped with means to prevent operation of either unit, unless the damper is in the full heat or cool position.

*A cooling unit is an air conditioning coil, heat pump coil or chilled water coil.

COMBUSTION AND VENTILATION AIR

This furnace is intended to use outside air for combustion. Failure to connect the air intake to the outside may result in premature failure of the heat exchanger. Figures 1, 3, 4 and 6 show a typical air intake connection. Connection of the air intake is a requirement for limited lifetime warranty of primary and secondary heat exchangers to be in effect. Refer to instructions on page 10 for combustion air intake. Consult local codes and ordinances for requirements applicable to your specific furnace installation conditions and comply with them. Provisions must be made for adequate combustion and ventilating air in accordance with Section 5.3, air for combustion and ventilation, of the National Fuel Gas Code, ANSI Z223.1--latest edition, or applicable provisions of the local building codes.

Adequate provisions for ventilating air must be made. If the furnace is installed in a closet or utility room, ventilating air must be allowed to enter the room through two permanent openings of equal area. One opening shall be located within twelve (12) inches of the ceiling and one opening within twelve (12) inches of the floor. Each opening shall have a face area of one (1) square inch per 1000 BTU/HR, but not less than 100 square inches.

CAUTION

When a furnace is installed in a closet or utility room, never use this room as a return air plenum.

VENTING

This Category IV furnace removes both sensible and latent heat from the combustion flue gases. Removal of latent heat results in condensation of flue gas water vapor. This condensed water vapor drains from the secondary heat exchanger into a 29-4C stainless steel drain pan. The condensate exits the drain pan by means of 3/8 I.D. vinyl hose. See Figure 1.

This furnace must be vented to the outdoors with either 2 inch round or 3 inch round PVC (poly-vinyl chloride) or CPVC (chlorinated poly-vinyl chloride) schedule 40 vent pipe unless local codes do not allow PVC or CPVC. See Table 3 for vent size selection. The following substitutes are permitted, only when approved by and installed in accordance with local codes. Polypropylene (PP), Polyethylene (PE), Polybutylene (PB) and Acrylonitrile-Butadiene-Styrene (ABS).

TABLE 3
PROPER VENT SIZE SELECTION

Furnace Models	Vent Length	Vent Diameter
CH060D36B, CC060D36A	3 - 60 Ft.	2" PVC
CH080D48B, CC080D48A	3 - 30 Ft.	2" PVC
CH080D48B, CC080D48A	*3 - 60 Ft.	3" PVC
CH100D60B, CC100D48A	3 - 60 Ft.	3" PVC
Vent length given is in equivalent foot measurements. Refer to Item 1, General Instructions.		
*If vent length is 30 to 60 ft., 3" pipe must be run the entire length.		

When substitute piping is used, it must be connected to the furnace at the no-hub connector located inside the furnace vestibule. See Figure 1. All joints, fittings, etc. must be cemented, sealed, or mechanically connected to prevent leakage of flue gases.

This vent must be installed in compliance with Part 7, "Venting of Equipment", National Fuel Gas Code NFPA54/ANSI Z223.1-latest edition, local codes or ordinances, these instructions and good trade practices.

CAUTION

Each vent must serve only one furnace. Do not connect vent to existing vent or chimney.

General Instructions

1. The maximum vent length is 60 total equivalent feet with each 45 degree elbow counting as 2-1/2 feet and each 90 degree elbow counting as 5 feet. Do not count the elbow within the furnace cabinet in this measurement.

Example: 20 feet of straight vent pipe with 3 - 90 degree elbows equals 35 equivalent feet.

2. Minimum horizontal vent length is 3 feet and 1 elbow.
3. A maximum of 5 elbows permitted in the vent run.
4. Vent diameter must not be reduced.
5. All horizontal runs must slope upwards not less than 1/4 inch per foot from the furnace to the vent terminal.

NOTE: Elbows used to change from a vertical run to a horizontal run should be DWV type to provide the correct slope in the horizontal run. If other types of elbows are used, then 2 - 45 degree elbows should be used in place of one 90 degree, with elbows slightly misaligned to provide slope in the horizontal runs.

6. All horizontal vent pipe runs must be supported at least every 4 feet with metal pipe strapping. No sags or dips or low spots are permitted.

7. All vertical vent pipe runs must be supported every 4 feet where possible.
8. Do not install the vent pipe in the same chase with a vent from another gas or other fuel burning appliance.
9. Do not install the vent pipe within 6 inches of the vent pipe from another gas or other fuel burning appliance.
10. The vent pipe can be run in the same chase or adjacent to supply or vent pipe for water supply or waste plumbing.
11. The vent pipe must be insulated if there is any chance of condensate freezing inside the pipe. This can occur if the vent pipe passes through an unconditioned space such as attic, crawl, uninsulated chase or a masonry chimney. It can also occur where the vent terminates above the roof or if an exterior vertical riser (Figure 2) is used to get above snow levels. Local climatic conditions and vent length must be considered. If vent height above roof exceeds 30 inches because of snow accumulation it must be insulated.

Types Of Insulation

FOR INDOOR OR OUTDOOR USE

Armaflex closed cell foam or equal. Recommended thickness is one inch. Additional layers may be required for extreme cold climate conditions.

FOR INDOOR USE ONLY

Fiberglass insulation with vapor barrier, or equal. Recommended thickness of 1 inch up to 10 feet. 2 inch thickness if unconditioned exposure exceeds 10 feet.

Connecting Vent to Furnace

The furnace is shipped from the factory with a 2" PVC street ell installed in the furnace vestibule. This is the point where field connection is made.

UPFLOW MODELS--CH SERIES

1. Cut a piece of 2" PVC pipe 21" long and connect one end to the 2" street ell located inside the furnace vestibule.

DOWNFLOW MODELS--CC Series

1. Cut a piece of 2" PVC pipe 40-3/4" long. Slide one end through top of cabinet and through the hole in the blower base and into the 2" street ell located inside the furnace vestibule.
2. Attach 2" no-hub connector just above the top panel of the furnace. See Figure 1. This fitting will help support the weight of the vent system.
3. If 3" vent is required (see Table 3) it is at this point where the vent should be increased. Cut a 3" length of 2" PVC and insert one end into the open end of the no-hub connector. Install a 2" x 3" PVC reducer on the top of the 2" nipple. Run the 3" PVC from this point on to the point of termination. See Figure 3.

A typical vent installation is shown in Figure 4.

- A. When vent penetrates through the roof and is brought above anticipated snow level, it is recommended that the pipe be cut off on a 45 degree angle. This will help prevent freezing and blockage of the vent system.
- B. If necessary to insulate vent pipe and a chimney is used as a chase, the top of the chimney must be sealed flush, or crowned up, so only the vent pipe protrudes.

Joining Pipe and Fittings

All pipe, fittings, solvent cement, primers and procedures must conform to American National Standard Institute and American Society for Testing and materials (ANSI/ASTM) standards.

Pipe and Fittings--ASTEM D1785, D2466 & D2665 PVC Primer and Solvent Cement--ASTM D2564 Procedure for Cementing Joints Ref ASTM D2855.

WARNING

DANGER OF FIRE OR BODILY INJURY

PVC SOLVENT CEMENTS AND PRIMERS ARE HIGHLY FLAMMABLE. PROVIDE ADEQUATE VENTILATION AND DO NOT ASSEMBLE NEAR HEAT SOURCE OR OPEN FLAME. DO NOT SMOKE.

AVOID SKIN OR EYE CONTACT. OBSERVE ALL CAUTIONS AND WARNINGS PRINTED ON MATERIAL CONTAINERS.

All joints in the PVC vent must be properly sealed using the following material and procedure.

CAUTION

FOR PROPER INSTALLATION:

DO NOT use solvent cement that has become curdled, lumpy or thickened.

DO NOT thin. Observe shelf precautions printed on containers.

For application below 32 degree F use only low temperature type solvent cement.

PVC Cleaner-Primer And PVC Medium Body Solvent Cement

1. Cut pipe end square, remove ragged edges and burrs. Chamfer end of pipe, then clean fitting socket and pipe joint area of all dirt, grease or moisture.
2. After checking pipe and socket for proper fit, wipe socket and pipe with cleaner-primer. Apply a liberal coat of primer to inside surface of socket and outside of pipe. DO NOT ALLOW PRIMER TO DRY BEFORE APPLYING CEMENT.
3. Apply a thin coat of cement evenly in the socket. Quickly apply a heavy coat of cement to the pipe end and insert pipe into fitting with a slight twisting movement until it bottoms out.

NOTE: Cement must be fluid, if not, recoat.

4. Hold the pipe in the fitting for 30 seconds to prevent the tapered socket from pushing the pipe out of the fitting.
5. Wipe all excess cement from the joint with a rag. Allow 15 minutes before handling. Cure time varies according to fit, temperature and humidity.

NOTE: Stir the solvent cement frequently while using. Use a natural bristle brush or the dauber supplied with the can. The proper brush size is one inch.

Horizontal Vents

The furnace may be vented horizontally through an outside wall, using all of the applicable instructions under Vent Pipe Installation with these additional requirements. The requirements and limitations for Horizontal Venting are very strict. ALL HORIZONTAL VENT INSTALLATIONS MUST BE MADE IN ACCORDANCE WITH THESE INSTRUCTIONS.

Vent Location

The vent location must meet the requirements listed in the following instructions or applicable codes, whichever specifies the most clearance or strictest limitations.

<p style="text-align: center;">WARNING</p> <p>THE COMBUSTION PRODUCTS AND MOISTURE IN THE FLUE GASES MAY CONDENSE AS THEY LEAVE THE TERMINAL ELBOW. THE CONDENSATE MAY FREEZE ON THE EXTERIOR WALL, UNDER THE EAVES AND ON SURROUNDING OBJECTS. SOME DISCOLORATION TO THE EXTERIOR OF THE BUILDING MAY OCCUR.</p>
--

Location Requirements

The vent must be installed with the following minimum clearances and requirements.

1. 12 inches above ground level, above normal snow levels (when practical) and 6 inches out from the wall. See Figure 5.

NOTE: Ice or snow may cause the furnace to shut down if the vent becomes obstructed. If required use a vertical riser or shield vent to prevent blockage from drifting snow. See Figure 2.

2. Not above the walkway or area that may create a hazard or nuisance or be detrimental to the operation of other equipment.
3. 4 feet from and not above or below any door, window, gravity inlet or forced air inlet for the building.
4. At least 4 feet from any soffit or under eave vent.
5. Do not vent under any kind of patio or deck.
6. Locate vent on the side of the building away from prevailing winter winds when practical but taking into consideration other limitations to determine the best overall location. If installed on a side with prevailing winds, consider the possible effects of moisture damage from freezing on walls or overhangs (under eaves) and use protective measures such as shielding and/or sealing cracks, seams and joints but extend area of sealing to minimum of 6 feet. On masonry surfaces, use a rust resistant shield (18" square)

Figure 1

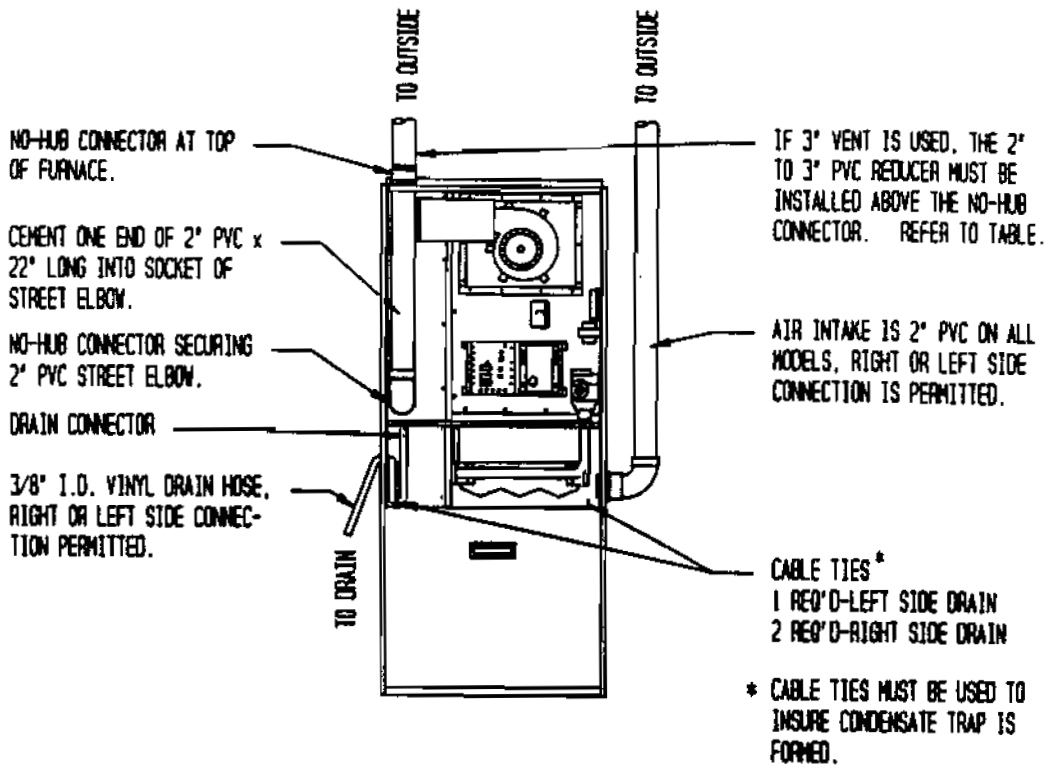

Figure 2

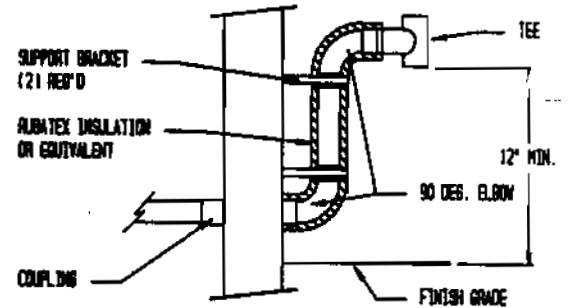

Figure 3

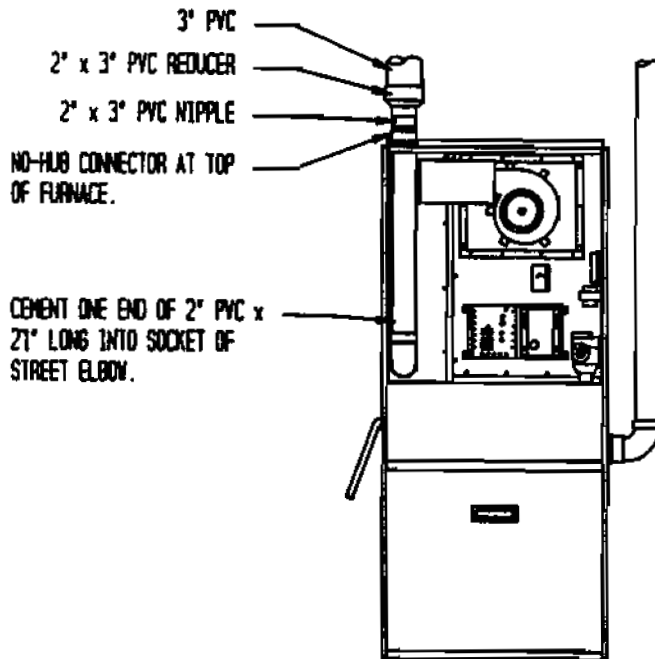
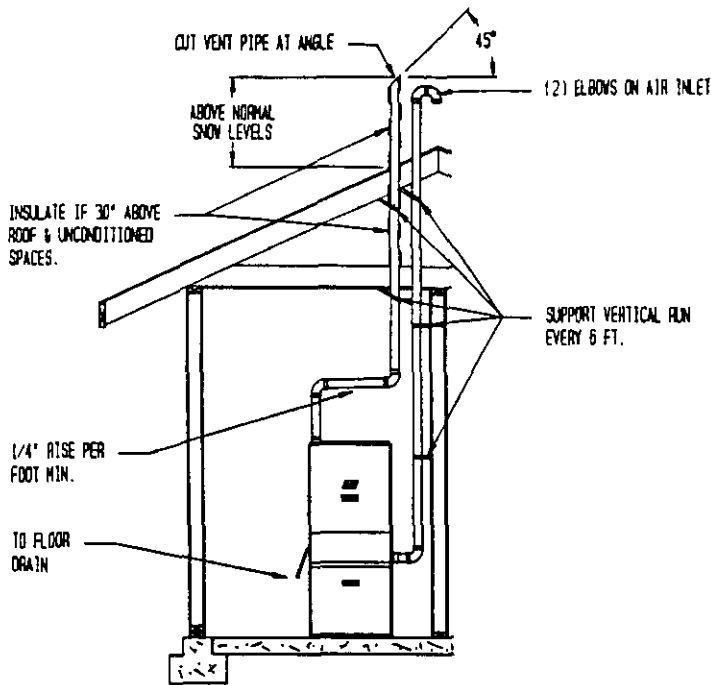

FIGURE 4



CAUTION

As a natural part of the unit's operation, normal products of combustion, including water vapor are vented to the atmosphere. Since the outside air temperature can be well below 32 degree F., it is possible that the water vapor in the exhaust will freeze, causing an ice buildup around the discharge opening of the pipe. During periods of extremely cold weather and prolonged operation of the furnace, this ice build-up could become quite large. The manufacturer does not recommend the installation of these units in locations above frequent vehicular and/or pedestrian traffic. The ice build-up could present a potentially hazardous situation if it becomes dislodged. The manufacturer will NOT be held responsible for any injury or property damage resulting from any improper installation.

FIGURE 5

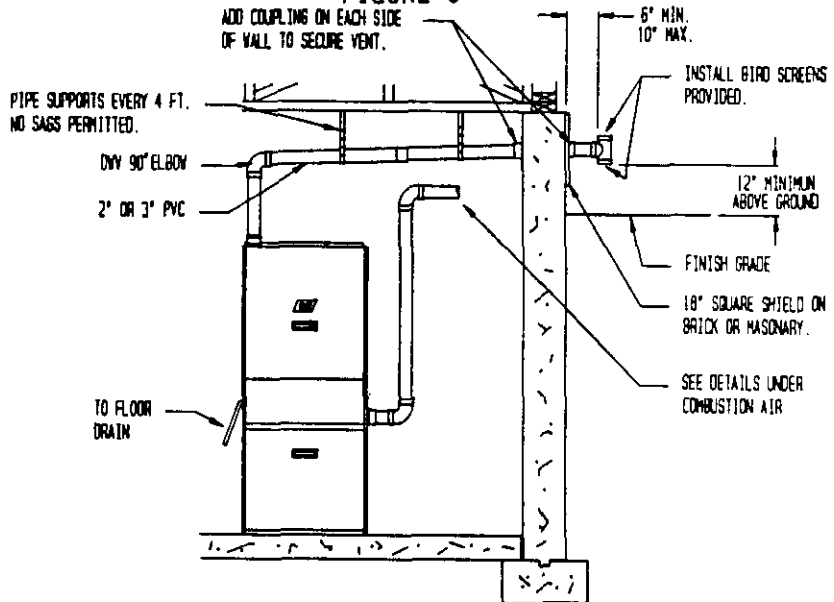
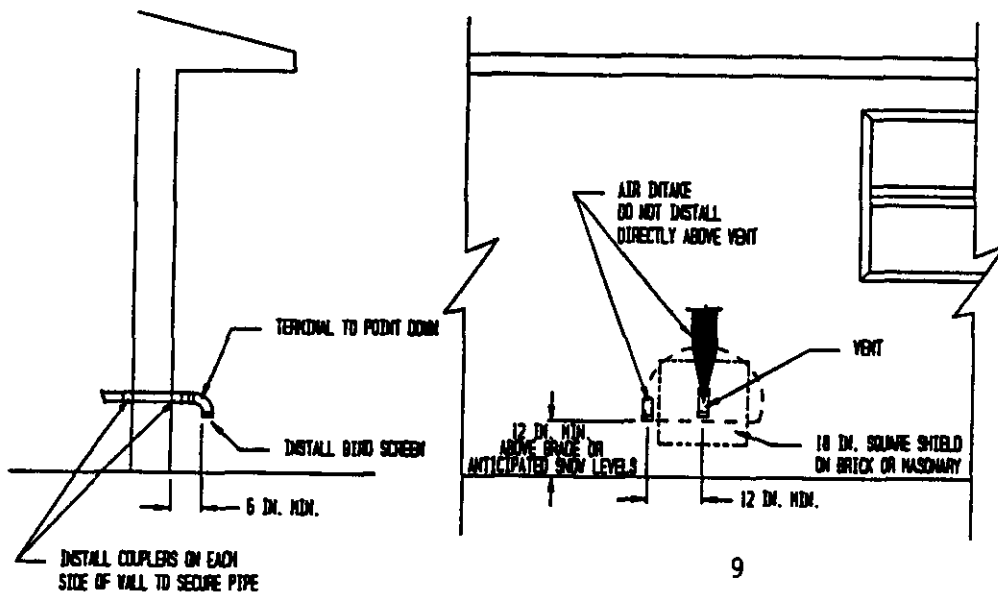

FIGURE 6



behind vent. If a vertical rise is used, the shield must extend 9" above and 9" below as shown in Figure 5. Shield can be wood, plastic, sheet metal, etc.

7. Do not locate too close to shrubbery as condensate may stunt or kill them.
8. Caulk all cracks, seams, and joints within 3 feet of vent.

A typical horizontal vent installation is shown in Figure 5.

Vent Termination

The vent termination will consist of either a 2" or a 3" PVC tee, dependant upon vent size. The tee is to be a minimum of 6" out from the wall and 12" above finish grade. Bird screens are provided and are to be installed in both the top and the bottom of the tee.

To exit the structure, a round hole is to be cut large enough to accommodate the pipe, yet smaller than the coupling so that a coupling installed on each side of the wall will prevent the vent pipe from being pulled out or pushed in the wall. See Figure 5.

COMBUSTION AIR INTAKE

This furnace is intended to use outside air for combustion. Failure to connect the air intake to the outside may result in premature failure of the heat exchanger. Figures 1 and 4 show a typical air intake connection. Connection of the air intake is a requirement for limited lifetime warranty of primary and secondary heat exchangers be in effect.

When installing the air intake, these guidelines must be followed.

1. The air intake may be connected to either the left side or right side of the furnace cabinet using the adapter and locknut shipped with the unit. The unused opening in the cabinet is to be plugged with the large hole plug supplied.
2. The air intake pipe is 2" PVC. The minimum horizontal length of the air intake is 3 equivalent feet and one elbow, the maximum length is 60 equivalent feet, with each 45 degree elbow counting as 2-1/2 feet and each 90 degree elbow counting as 5 feet (refer to Venting, General Instructions for example). Do not count the 90 degree elbow at the furnace side in this measurement.
3. The air intake terminal must be at least 12 inches away from the vent terminal, 6 inches out from the wall, and not directly above the vent terminal. See Figure 6.
4. Air intake terminal must be 12" above ground or above anticipated snow levels.
5. The bird screen supplied is to be installed into the end of the 90 degree elbow (see Figures 4 and 6).
6. Follow rules under venting for joining pipe and fittings.
7. On vertical intake, two 90 degree elbows must be used at the terminal to prevent moisture from entering the air intake (see Figure 4).
8. On horizontal air intakes one 90 degree elbow must be used on the termination. This elbow must point down to prevent moisture from entering the air intake (see Figure 6).
9. Attach couplings on each side of the wall to prevent pipe from being pushed in or pulled out.

CONDENSATE DRAIN/NEUTRALIZER

The drain tubing that is provided with this unit is for the purpose of removing condensation from the furnace. A condensate trap is required for operation and is easily obtained when installed as shown in Figure 8. Figure 8 pictorially shows the up-flow model. However, the drain installation for both the up-flow and down-flow units consist of the same configuration with the exception of the silicone tubing used on the down-flow version. The drain line should slope "downhill" to the drain after exiting the furnace cabinet. Excessive condensate trap (long uphill and/or level runs) can cause the furnace to malfunction.

The silicone tubing which is supplied with the down-flow models measures 3/8" I.D. x 5/8" O.D. x 36" long and is to be used within the confines of the burner compartment. Two wire ties, supplied in the installation parts kit provided with each unit, are used to secure the silicone drain tubing to the lower base. Slide the wire ties through dimple holes in the base and loop around drain line as shown on drain installation instructions provided with the installation parts kit. Once the silicone drain tubing has exited the cabinet, the PVC flex tubing measuring 3/8" I.D. x 1/2" O.D. x 30" long may be used to reach the drain. A 3/8" barbed hose coupling which is also provided may be used to couple the silicone drain tube and the PVC drain tube together. Schedule 40 PVC pipe may also be used once outside the cabinet. Remember, once out of the cabinet, installing a drain which runs to a point higher than the exiting point can cause furnace malfunction.

The drain tubing supplied with the up-flow versions measures 3/8" I.D. x 1/2" O.D. x 60" long and is a clear PVC flex tubing. No silicone tubing is required for the up-flow models. The drain is assembled in the same manner as the down-flow except the wire tie(s) for securing the flex tubing are already secured into the blower base and the flex tubing is used both internally and externally to the unit. (See Figure 8.)

WARNING

Do not run drain to an area where temperature may drop below freezing point (32 degree F). Freezing of condensate could result in property damage or furnace malfunction.

If no floor drain is available, a condensate pump or sump pump must be used for pumping condensate to the nearest drain. A condensate neutralizer cartridge must be used with either type of pump. If a condensate pump is used, or if local codes require, install a condensate neutralizer cartridge in the drain line. (See Figure 8).

The drain line exiting points are located above combustion air intake holes in either side of the cabinet (see Figure 8). Whichever hole (7/8" diameter) being used for the drain line should have the snap bushing inserted in the hole prior to inserting the tubing. The opposing hole should be plugged with hole plug provided.

FIGURE 8

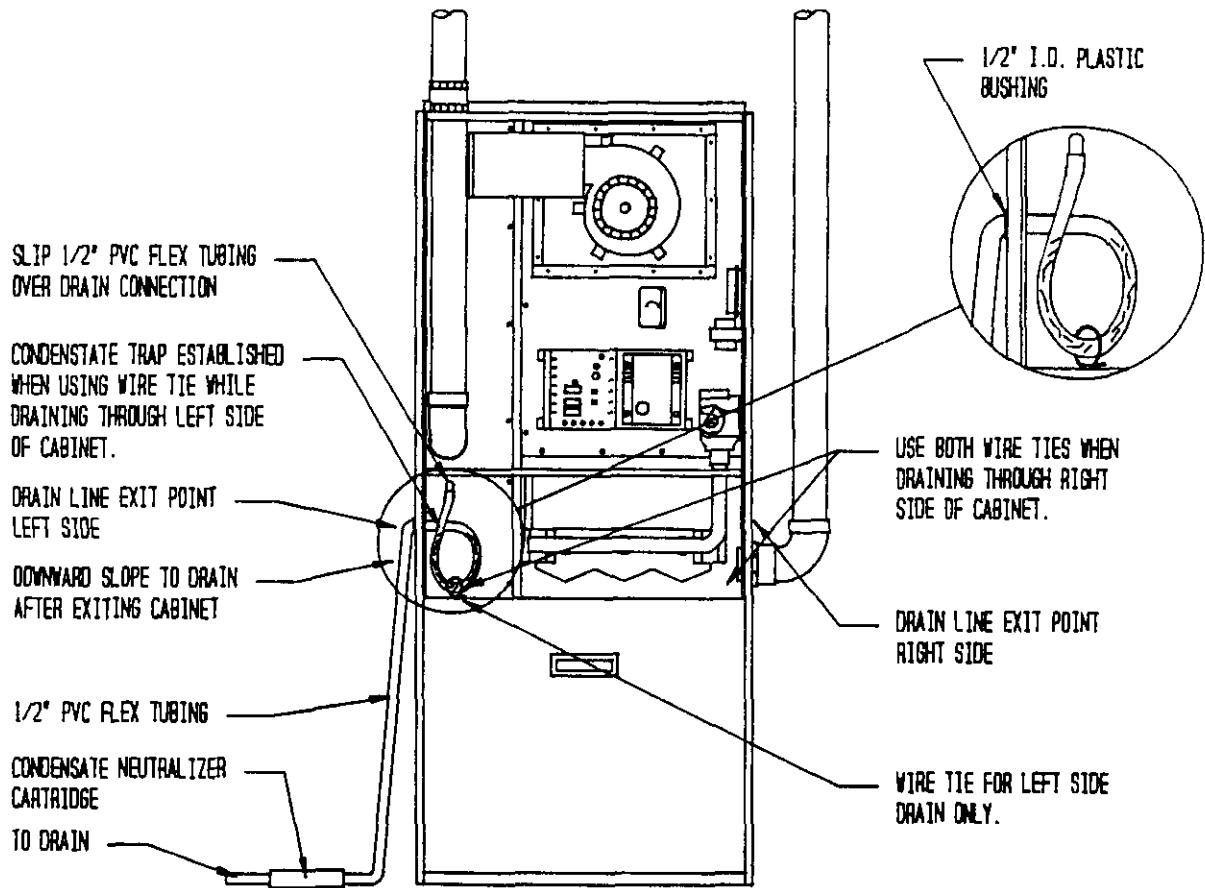

GAS SUPPLY AND PIPING

General Recommendations

1. Be sure the gas line complies with the local codes and ordinances, or in their absence with National Fuel Gas Code, ANSI Z223.1-latest edition.
2. A sediment trap or drip leg must be installed in the supply line to the furnace.
3. A ground joint union shall be installed in the gas line adjacent to and upstream from the gas valve and downstream from the manual main shut-off valve.
4. A 1/8" N.P.T. plugged tapping accessible for test gauge connection shall be installed immediately upstream of the gas supply connection to the furnace for the purpose of determining the supply gas pressure.
5. A manual shut-off valve shall be installed in the supply gas line external to the furnace when required by local code. See Figure 7.
6. Use steel or wrought iron pipe and fittings.
7. DO NOT thread pipe too far. Valve distortion or malfunction may result from excess pipe within the control. Use pipe joint compound resistant to the action of liquified petroleum gases on male threads only. DO NOT use Teflon tape. See illustrations.
8. Refer to Tables 4 and 5 for Gas Pipe Sizes for Natural and L.P. gas. If more than one appliance is supplied from a single line size, capacity must equal or exceed the combined input to all appliances, and the branch lines feeding the individual appliances properly sized for each input.

FIGURE 7

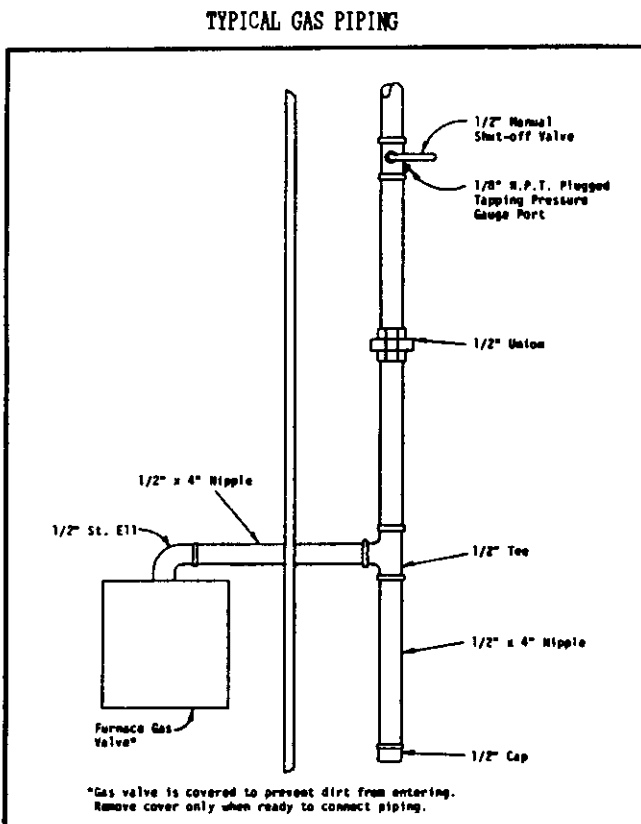

LENGTH OF STANDARD PIPE THREADS (Inches)

Pipe Size	Effective Length of Thread	Overall Length of Thread
3/8	3/8	9/16
1/2	1/2	3/4
3/4	1/2 - 9/16	13/16
1	9/16	1

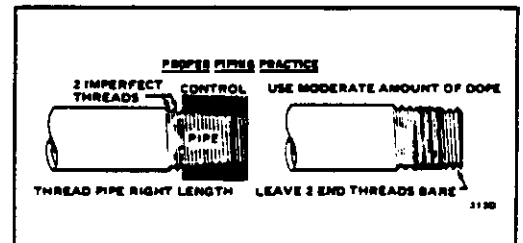

	GAS PRESSURES		
	Min. Supply	Max Supply	Manifold
Nat.	4.5"	11.0"	3.5"
L.P.	11.0"	13.0"	10.0"

Measured in inches water.

Checking The Gas Piping

Before turning gas under pressure into piping, all openings from which gas can escape should be closed. Immediately after turning on gas, the system should be checked for leaks. This can be done by watching the 1/2 cubic foot test dial and allowing 5 minutes to show any movement, and by soaping each pipe connection and watching for bubbles. If a leak is found, make the necessary repairs immediately and repeat the above test. The furnace must be isolated from the gas supply piping system by closing the manual shutoff valve on the combination gas control valve during pressure testing of the gas supply piping system at pressures up to 1/2 psig. The furnace must be disconnected from supply piping and supply piping capped during any pressure testing of supply piping system at test pressure in excess of 1/2 psig.

Defective pipes or fittings should be replaced and not repaired. Never use a flame or fire in any form to locate gas leaks, use a soap solution.

After the piping and meter have been checked completely, purge the system of air. DO NOT bleed the air inside the furnace. Be sure to relight all the gas pilots on other appliances that may have been extinguished because of interrupted gas supply.

TABLE 4
GAS PIPE SIZES/CAPACITY
NATURAL GAS

Length of Pipe--Ft.	Capacity--Btuh Per Hour Input		
	Pipe Size		
	1/2"	3/4"	1"
20'	92,000	190,000	350,000
40'	63,000	130,000	245,000
60'	50,000	105,000	195,000

TABLE 5
GAS TUBING AND PIPE SIZES
L.P. GAS

Length In Feet	Capacity--Btu Per Hour Input			
	Copper Tubing*		Iron Pipe	
	1/2***	3/4***	1/2"	3/4"
20'	62,000	216,000	189,000	393,000
40'	41,000	145,000	129,000	267,000
60'	35,000	121,000	103,000	217,000

*Copper tubing for gas supply must comply with limitation in National Fuel Gas Code, reference "2.6.3 Metallic Tubing".

**Outside diameter.

WIRING

CAUTION

For your personal safety, turn off electric power at service entrance panel before making any electrical connections.

All electrical work must conform with local codes and ordinances, or in their absence, with the National Electrical Code, ANSI/NFPA 70-latest edition.

Electrical Power Supply

Run a separate 120 volt, 15 ampere, 60 HZ, AC circuit from a separate fuse or circuit breaker in the service entrance panel. Locate a shut-off switch at the furnace. Make connections from this switch to furnace junction box as shown in the furnace wiring diagram.

Electrical Grounding

A. RECOMMENDED GROUNDING METHOD

When installed, the furnace must be electrically grounded in accordance with local codes or in the absence of local codes, with the National Electrical Code, ANSI/NFPA No. 70-latest edition. Use a #14 AWG copper wire from green screw or green ground wire on the furnace to a grounded connection in the service panel or a properly driven and electrically grounded ground rod.

THERMOSTAT

Install the thermostat in accordance with instructions packed with it. Locate the thermostat 4-1/3 feet from the floor on an inside wall away from drafts, warm air registers and floor or table lamps. Refer to furnace wiring diagrams for connections.

All 24V wall thermostats have heat anticipators to compensate the thermostat for various system controls and allow the best possible cycle rates. Some anticipators are fixed and require no adjustment. However, the majority of wall thermostats have adjustable anticipators and do require adjustment to match the current rating of the thermostat circuit. Nominal rating of thermostat circuit is .80A, however, actual amp draw through the thermostat should be checked to determine heat anticipator setting.

Failure to adjust the anticipator lever to correspond to the actual current draw through the thermostat will cause severe short cycling if set too low and room temperature may never attain the thermostat set point, and if set too high, will cause room temperature to overshoot the set point.

BLOWER OPERATION

All models are three or four speed direct drive and are equipped with a heating-cooling blower relay. When matched with the appropriate wall thermostat, offers manual blower operation from the wall thermostat for air circulation.

CAUTION

After the furnace is operating with filters installed and all cabinet panels are in place, check the temperature rise through the unit to insure it is within the range specified on the furnace rating plate. If it is not, adjust blower speed until the temperature rise is within specified range.

Field Installed Equipment

Wiring to be done in the field between the furnace and devices not attached to the furnace, or between separate devices which are field installed and located, shall conform with the temperature limitation for Type T wire (63 degree F rise (36 degree C)) when installed in accordance with the manufacturer's instructions. Refer to wiring diagrams.

FILTERS

All models are shipped with filters. See Table 6 for sizes. Hi-Boy Models have the filters in their intended positions. Hi-Boy models are shipped with filter on the left side. They can alternately be located on right side or bottom. See following information. The counterflow models require a bracket installation and final filter location projects into return air plenum attachment to furnace. See Figure 10A.

TABLE 6

Filter Size for Gas furnace	
Model	Size
CHO60D36B	1 - 16x25x1
CCO60D36A	2 - 10x20x1
CHO80D48B	1 - 16x25x1
CCO80D48A	1 - 10x20x1, 1 - 15x20x1
*CH100D60B	1 - 16x25x1
CC100D48A	1 - 10x20x1 1 - 15x20x1

*2-16x25x1 for 5 tons of cooling.

Filter Locations--Removal and Replacement Procedures--All Hi-Boy Furnaces

To remove filters from ALL sectional Hi-Boys, remove the lower blower compartment door by grasping the handle in the door and pull up and away from the furnace. Then, remove the "S" clip and spring by pulling the clip towards front of the furnace.

For right hand side filter location, relocate filter and retaining spring assembly to right side filter brackets.

FIGURE 9

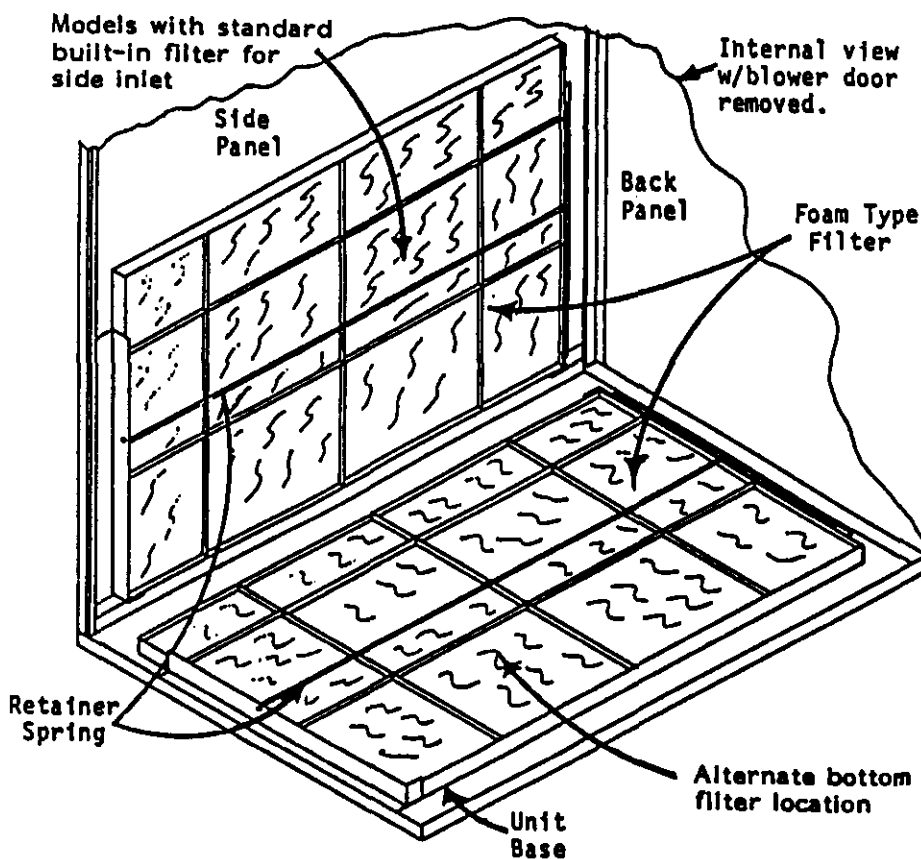

The filter may now be removed simply by pulling it towards the center of the furnace and outward.

The location may vary, depending on which side the installer located the return air duct.

This filter is the permanent high velocity type foam filter which may be washed and used over and over. DO NOT replace it with a fiberglass filter of the same size.

To replace filter, reverse the above process.

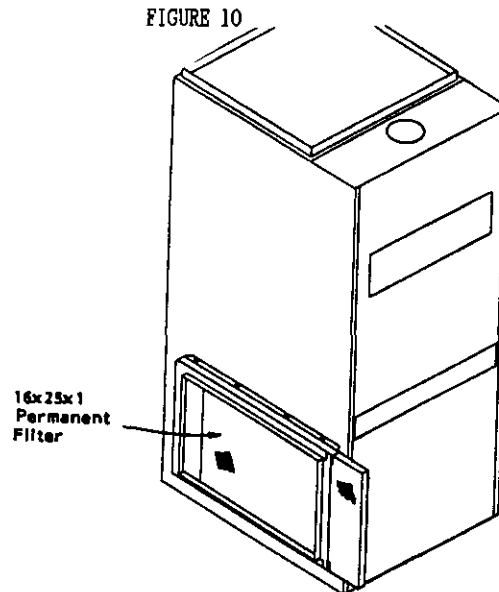

To remove filter from the optional external filter rack, grasp the exposed end of the filter and pull from the filter rack.

The location may vary, depending on which side the installer located the return air duct.

This filter is the permanent high velocity type foam filter which may be washed and used over and over. DO NOT replace it with a fiberglass filter of the same size.

To replace filter, reverse the above process.

Alternate Bottom Filter Location

All Hi-Boy models have a removable panel on the base for a bottom return air installation.

To utilize this feature, remove the fill plate by bending the four tabs up 90 degrees. Relocate filter retainer spring from side to bottom brackets. Leave the four tabs bent in the upright position as they will now serve to keep the filter positioned left to right.

Five Ton Cooling Capacity

If the model CH100D60B is used with 60,000 BTU cooling capacity, then 2 return air openings are required. This can be accomplished by using both sides of the furnace or one side and the bottom return. The furnace is shipped with one 16x25 permanent filter, one additional filter is required for this application.

FILTER LOCATIONS--COUNTERFLOW MODELS

Counterflow models normally have filters installed in the return air plenum above the furnace unless a common return air/filter grille is used. Refer to figures 10A and 10B for suggested filter locations.

FIGURE 10A

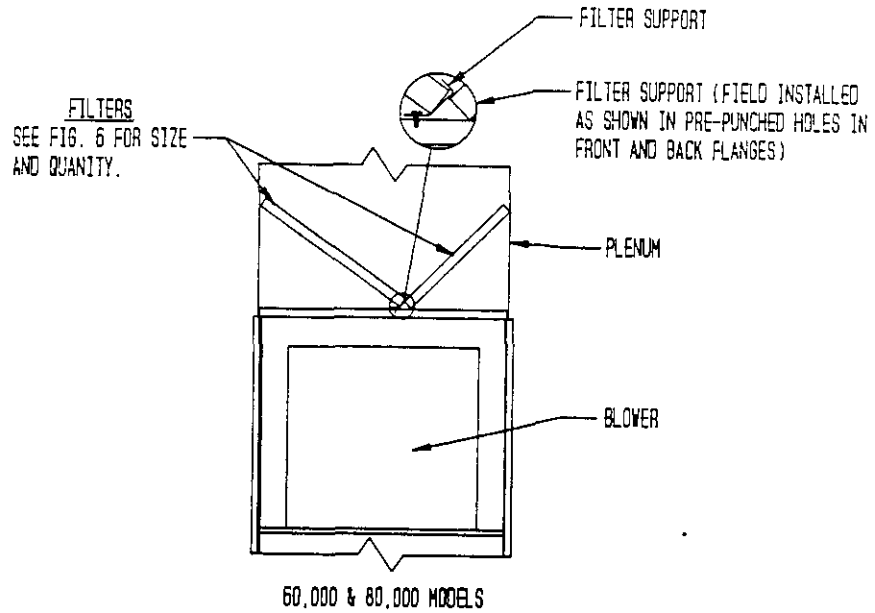
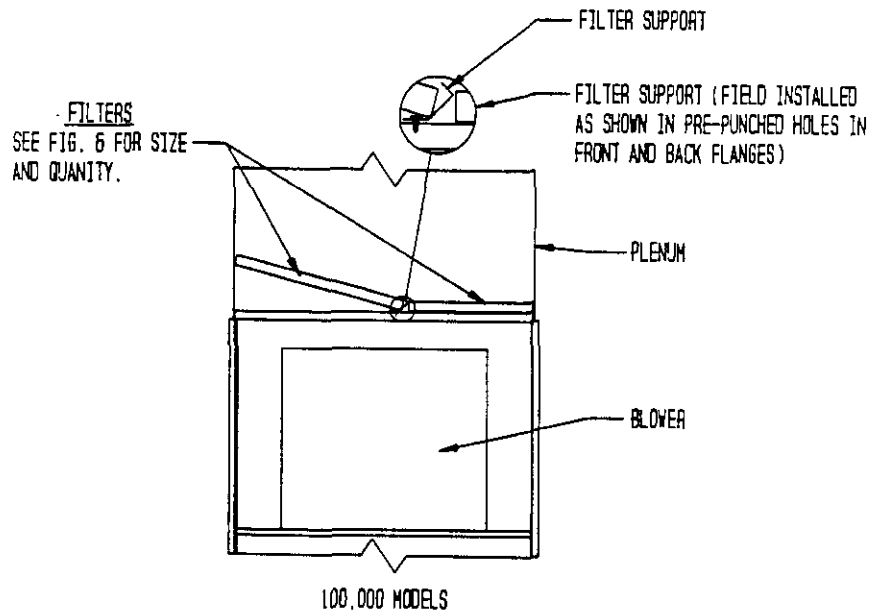

FIGURE 10B



FOR YOUR SAFETY READ BEFORE OPERATING

WARNING: If you do not follow these instructions exactly, a fire or explosion may result causing property damage, personal injury or loss of life.

- A. This appliance is equipped with an ignition device which automatically lights the pilot. Do not try to light the pilot by hand.
- B. BEFORE OPERATING smell all around the appliance area for gas. Be sure to smell next to the floor because some gas is heavier than air and will settle on the floor.
- WHAT TO DO IF YOU SMELL GAS**
- Do not try to light any appliance.
 - Do not touch any electric switch; do not use any phone in your building.
 - Immediately call your gas supplier from a neighbor's phone. Follow the gas supplier's instructions.
- If you cannot reach your gas supplier, call the fire department.
- C. Use only your hand to push in or turn the gas control knob. Never use tools. If the knob will not push in or turn by hand, don't try to repair it, call a qualified service technician. Force or attempted repair may result in a fire or explosion.
- D. Do not use this appliance if any part has been under water. Immediately call a qualified service technician to inspect the appliance and to replace any part of the control system and any gas control which has been under water.

OPERATING INSTRUCTIONS

1. STOP! Read the safety information above on this label.
2. Set the thermostat to lowest setting.
3. Turn off all electric power to the appliance.
4. This appliance is equipped with an ignition device which automatically lights the pilot. Do not try to light the pilot by hand.

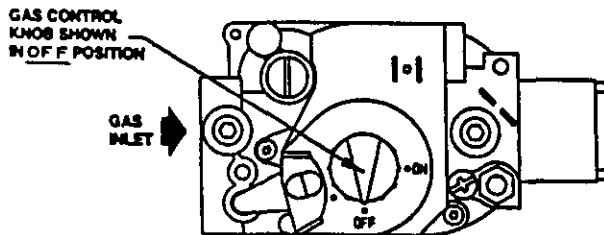

5. Remove control access panel.
 6. Push in gas control knob slightly and turn clockwise to "OFF."
- NOTE: Knob cannot be turned to "OFF" unless knob is pushed in slightly. Do not force.
7. Wait five (5) minutes to clear out any gas. If you then smell gas, STOP! Follow "B" in the safety information above on this label. If you don't smell gas, go to next step.
 8. Turn gas control knob counterclockwise to "ON."
 9. Replace control access panel.
 10. Turn on all electric power to the appliance.
 11. Set thermostat to desired setting.
 12. If the appliance will not operate, follow the instructions "To Turn Off Gas To Appliance" and call your service technician or gas supplier.

TO TURN OFF GAS TO APPLIANCE

1. Set the thermostat to lowest setting.
2. Turn off all electric power to the appliance if service is to be performed.
3. Remove control access panel.
4. Push in gas control knob slightly and turn clockwise to "OFF." Do not force.
5. Replace control access panel.

SEQUENCE OF OPERATION

On a call for heat from the thermostat, the induced draft blower relay is energized through the normally closed contacts of the air proving pressure switch. At this point the induced draft blower starts its operation. Once sufficient draft is established, the ignition module is energized through the normally open contacts of the air proving pressure switch. The pilot ignition electrode will begin to spark and the pilot valve will be energized allowing pilot gas to flow. Upon establishment of the pilot burner flame, adequate flame for burner ignition is proved to the control module allowing the main gas valve is to be energized and to discontinue ignition spark. At the same time the main valve is energized, a one minute blower delay timer is activated.

After this delay, the low speed blower relay energizes. The blower will begin operating and remain in operation until two minutes after the call for heat has been satisfied. This timing sequence guarantees blower on, blower off operation.

MAINTENANCE INSTRUCTIONS

The furnace and its vent system should be inspected annually by a qualified service agency, generally prior to the heating season.

NOTE: PRIOR TO THE START OF ANY OF THE FOLLOWING MAINTENANCE PROCEDURES SHUT OFF ALL POWER TO THE UNIT.

Routine maintenance procedures are the responsibility of the owner and are contained in the Owner's Manual. These are briefly outlined below:

1. Air Filters. Check the condition on at least a monthly basis when the furnace is in use or replace whenever it is necessary.
2. Lubrication Requirements. Direct drive motors are permanently lubricated, no maintenance required. The induced draft blower motor should be oiled every six months with SAE20 motor oil.
3. Periodic Inspection of the Vent and Air Intake. Visual inspection of the vent and air intake for any leaking, sags, dips or defective parts. The vent and intake should also be inspected outside of the structure for any blockage in the openings. If blockage is present, remove the bird screens and brush clean before putting them back in.
4. Periodic Inspection of Drain Line. The drain line on a condensing furnace should be checked monthly for blockage or freezing of drain condensate. Blockage of drain will prevent furnace operation.

--QUALIFIED TECHNICIANS ONLY--

Service Agency Procedures

The pilot flame can be adjusted by removing the pilot adjustment cover screw. Turn inner adjustment screw clockwise to decrease and counterclockwise to increase pilot flame. Be sure to replace cover screw after adjustment to prevent possible gas leakage.

Observe the main burners in operation. The flame should be mostly "blue" with possibly a little orange (not yellow) at the tips of the flame. The flames should be in the center of the heat exchanger compartments and not impinging on the heat exchanger surfaces themselves.

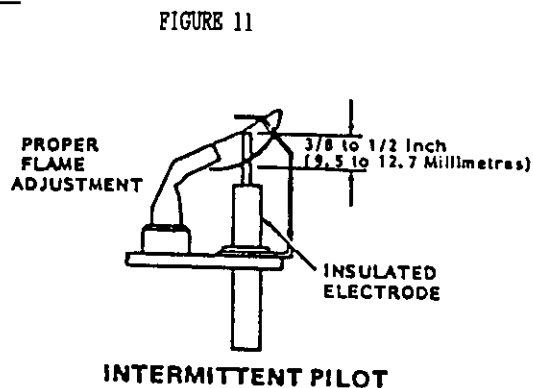

The air shutters are factory adjusted completely open. If flashback occurs, the air shutters may be closed slightly to prevent the flashback.

Observe the fire until the blower starts (there is a normal delay period until the heat exchanger warms up). There should be no change in the size or shape of the flame. If there is any wavering or blowing of the flame on blower start-up, it is an indication of a possible leak in the heat exchanger.

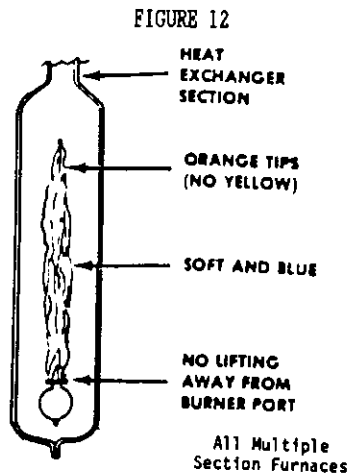

WARNING

Danger of property damage, bodily injury or death if electric power (at disconnect) and gas supply (at manual shutoff valve in gas line) are not shut off.

Inspect the burner assembly for any scaling, sooting or blockage of ports. If there are signs of this, the burner should be removed and cleaned with a wire brush until all soot and scale is removed and burner ports are not obstructed.

Check Temperature Rise--Adjust blower speed if necessary to obtain a temperature rise within the range specified on the furnace rating plate. See blower operation for details.

Heat Exchangers and Flue Gas Passageways

Furnaces that are properly installed and maintained will normally not require cleaning of the heat exchangers.

THE ONLY TIME it should be necessary to disassembly and clean the interior of both the Primary and Secondary Heat Exchangers would be due a sooting condition caused by abnormal combustion.

The inside of the heat exchanger can be examined for scale and soot using a light and a mirror on an extension handle. If soot and/or scale is evident, the heat exchanger must be cleaned as follows:

1. Remove burner assembly from inlet to heat exchanger.
2. Remove flue transition, combustion air blower, flue collector box and internal flue baffles from the outlet of the primary heat exchanger.
3. Using a small wire brush on extension handle brush inside walls of the heat exchanger until soot and/or scale is removed. The loose scale and/or soot is easily removed using a vacuum cleaner at the inlet side of the heat exchanger.
4. To clean the secondary heat exchanger, disconnect the 2 no-hub connectors securing the vent to the furnace. Remove the length of vent located in the furnace vestibule. Remove the 18 sheet metal screws securing the coil partition (partition located on left side when facing unit). Disconnect drain hose and remove burner partition. The secondary heat exchanger is now ready for removal.

5. Gently ease secondary heat exchanger straight forward away from back of furnace being careful not to damage the fins.
6. Once the coil is removed from the furnace, take it to a place where the following steps can be performed.
 - A. Set coil on its back so the inlet, outlet and drain openings are pointed up. Pour 2 quarts of hot water into the coil and cap off openings. Shake coil vigorously and pour out water. Repeat this procedure until the water being poured from the coil is clear.
 - B. Thoroughly wash off the exterior of the heat exchanger using a soft brush and a mild stream of water. DO NOT use a hard stream of water as this may damage the fins.

REPLACEMENT PARTS

Replacement parts for the gas furnaces are available through local distributor.

Parts list covering all furnace components is shown on page 21 - 26. When ordering parts or making inquiries pertaining to any of the furnaces covered by these instructions, it is very important to always supply the COMPLETE model number and serial number of the furnace. This is necessary to assure that the correct parts (or an approved alternate part) are issued to the service agency.

UPFLOW
FABRICATED PARTS

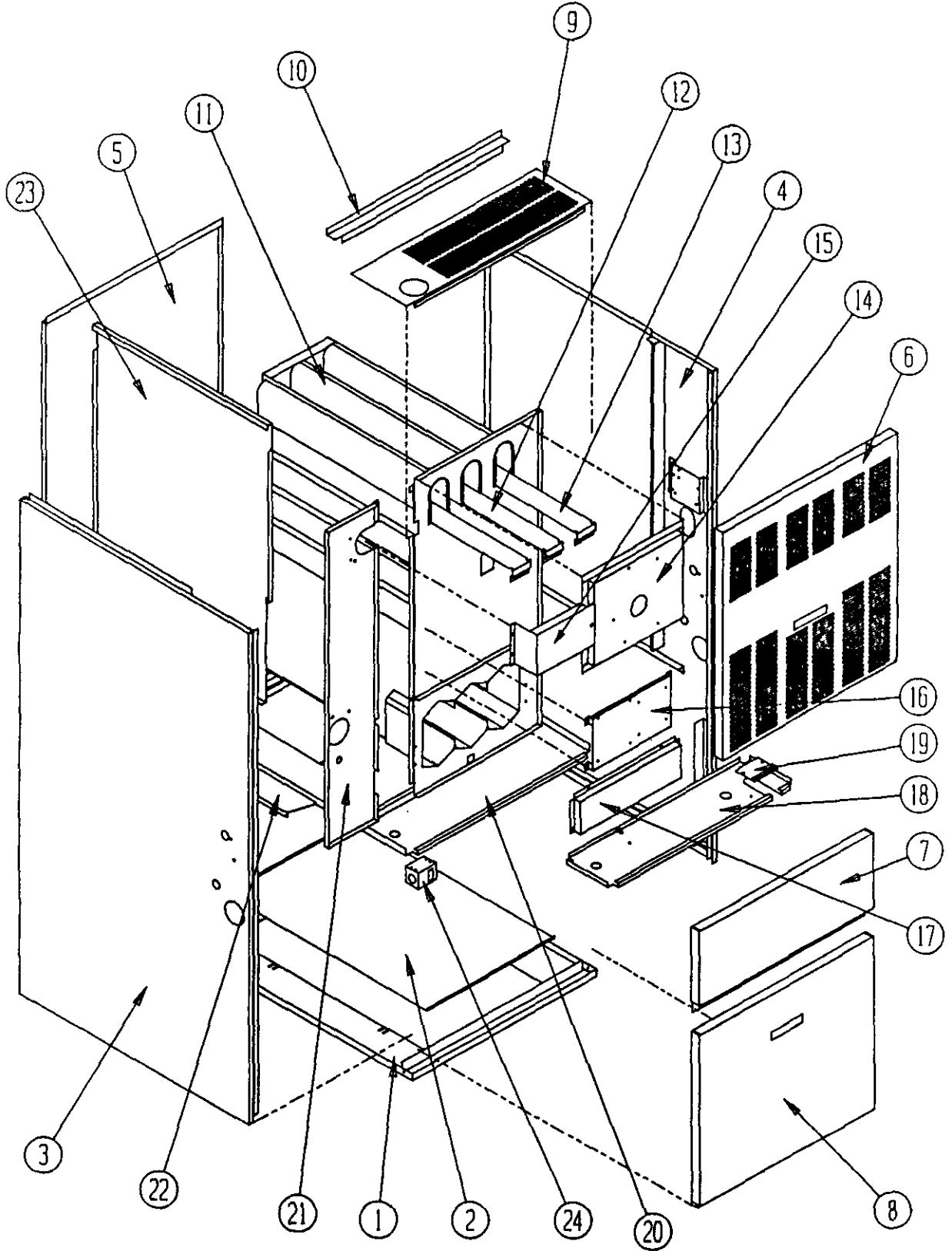

UPFLOW
PARTS LIST
FABRICATED PARTS

Date: 6-27-88

Dwg. No.	Part No.	Description	Date: 6-27-88		
			C H O 6 0 D 3 6 B	C H O 8 0 D 4 8 B	C H I 0 0 D 6 0 B
1	127-125	Lower Base Spotweld Assembly	X		
1	127-127	Lower Base Spotweld Assembly		X	
1	127-148	Lower Base Spotweld Assembly			X
2	136-121	Bottom Fill Plate	X		
2	136-121	Bottom Fill Plate		X	
2	136-133	Bottom Fill Plate			X
3	501-182	Left Side Assembly	X	X	X
4	501-181	Right Side Assembly	X	X	X
5	508-018	Back Assembly	X		
5	508-019	Back Assembly		X	
5	508-073	Back Assembly			X
6	152-148	Vestibule Door	X		
6	152-149	Vestibule Door		X	
6	152-150	Vestibule Door			X
7	152-145	Burner Door	X		
7	152-146	Burner Door		X	
7	152-147	Burner Door			X
8	152-151	Blower Door	X		
8	152-152	Blower Door		X	
8	152-153	Blower Door			X
9	106-111	Top Fill	X		
9	106-112	Top Fill		X	
9	106-113	Top Fill			X
10	140-134	Plenum Support	X		
10	140-135	Plenum Support		X	
10	140-136	Plenum Support			X
11	171-158	Heat Exchanger Assembly	X		
11	171-159	Heat Exchanger Assembly		X	
11	171-160	Heat Exchanger Assembly			X
12	168-013	Flue Baffle--Short		X	X
13	168-002	Flue Baffle	X	X	X
14	168-031	Flue Collector Box	X		
14	168-032	Flue Collector Box		X	
14	168-033	Flue Collector Box			X
15	913-0041	IDB Transition	X		
15	913-0038	IDB Transition Assembly		X	
15	913-0044	IDB Transition Assembly			X
*16	112-088	Ignition Module Bracket	X		
*16	112-089	Control Mounting Bracket		X	X
17	168-003	Secondary Air Baffle	X		

*80,000 and 100,000 ignition module bracket shown.

UPFLOW
PARTS LIST
FABRICATED PARTS

Date: 6-27-88

Dwg. No.	Part No.	Description	C	C	C
			H	H	H
			0	0	1
			6	8	0
			0	0	0
			D	D	D
			3	4	6
			6	8	0
			B	B	B
17	168-008	Secondary Air Baffle		X	
17	168-010	Secondard Air Baffle			X
18	120-120	Burner Compartment Partition	X		
18	120-121	Burner Compartment Partition		X	
18	120-122	Burner Compartment Partition			X
19	136-131	Manifold Fill Plate	X	X	
19	136-132	Manifold Fill Plate			X
20	127-149	Blower Base Weld Assembly	X		
20	127-120	Blower Base Weld Assembly		X	
20	127-146	Blower Base Weld Assembly			X
21	120-119	Coil Partition	X	X	X
22	140-133	Support Coil	X	X	X
23	134-098	Coil Shield	X	X	
23	134-099	Coil Shield			X
24	112-031	Door Switch Bracket	X	X	X

*80,000 and 100,000 ignition module bracket shown.

UPFLOW
MECHANICAL PARTS

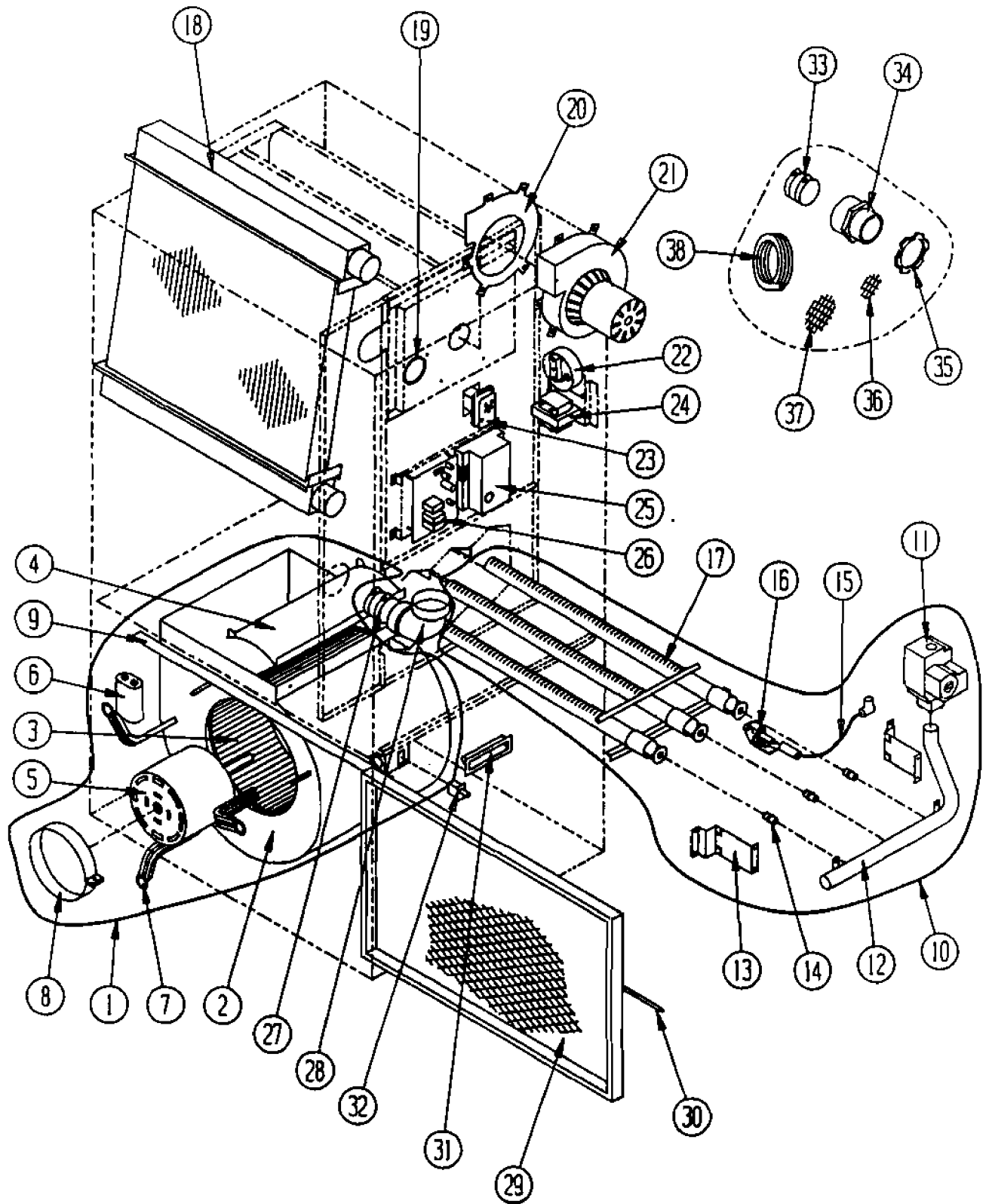

UPELOW
PARTS LIST
MECHANICAL PARTS

Date: 11-28-88

Dwg. No.	Part No.	Description	C	C	C
			H	H	H
			0	0	1
			6	8	0
			0	0	0
			D	D	D
			3	4	6
			6	8	0
			B	B	B
1	900-088	Blower Assembly	X		
1	900-094	Blower Assembly		X	
1	900-089	Blower Assembly			X
2	151-067	Blower Housing	X		
2	151-041	Blower Housing		X	
2	151-066	Blower Housing			X
3	5152-013	Blower Wheel	X		
3	5152-059	Blower Wheel		X	
3	5152-061	Blower Wheel			X
4	144-120	Diffuser	X		
4	144-088	Diffuser		X	
4	144-117	Diffuser			X
5	8105-008	Motor	X		
5	8106-018	Motor		X	
5	8107-004	Motor			X
6	8552-002	Capacitor	X		
6	8552-004	Capacitor		X	
6	8552-026	Capacitor			X
7	8200-034	Motor Mount Leg	X	X	
7	8200-035	Motor Mount Leg			X
8	8200-033	Motor Mount Strap	X	X	X
9	104-769	Blower Angle	X		
9	104-731	Blower Angle		X	X
10	901-0083	Burner Assembly	X		
10	901-0082	Burner Assembly		X	
10	901-0084	Burner Assembly			X
11	5651-062	Gas Valve	X	X	X
12	5818-019	Gas Manifold	X		
12	5818-020	Gas Manifold		X	
12	5818-021	Gas Manifold			X
13	112-079	Manifold Mounting Bracket	X	X	X
14	9010-010	Gas Orifice Spud	X		
14	9010-046	Gas Orifice Spud		X	X
15	8600-008	Ignition Cable	X	X	X
16	8554-009	Pilot Assembly	X	X	X
17	9010-036	Burner Venturi	X		
17	9010-037	Burner Venturi		X	
17	9010-038	Burner Venturi			X
18	5055-001	Coil Assembly	X	X	X
19	1921-020	Silicone Die-Cut Gasket	X	X	X

*80,000 and 100,000 ignition module bracket shown.

UPFLOW
PARTS LIST
MECHANICAL PARTS

Date: 2-16-89

Dwg. No.	Part No.	Description	C	C	C
			H	H	H
			0	0	1
			6	8	0
			0	0	0
			D	D	D
			3	4	6
			6	8	0
			B	B	B
20	1921-019	IDB Gasket	X	X	X
21	8620-033	Induced Draft Blower Assembly Kit	X	X	X
22	8406-041	Pressure Switch			X
22	8406-042	Pressure Switch		X	
22	8406-043	Pressure Switch	X		
23	8620-032	Limit Assembly	X	X	X
24	8407-039	Transformer	X	X	X
25	5651-060	Ignition Module	X	X	X
26	8201-053	Blower Control	X	X	X
27	6093-007	"No Hub" Connector	X	X	X
28	6095-005	90 Degree Street Elbow	X	X	X
29	7003-004	16x25xl Permanent	X	X	X
30	5401-002	Filter Spring	X	X	X
31	1171-025	Door Pull	X	X	X
32	8406-013	Door Switch	X	X	X
33	6093-008	"No Hub" Connector	X	X	X
34	6093-006	2" Male Adapter	X	X	X
35	8611-063	2" Conduit Lock Nut	X	X	X
36	7002-009	2" Bird Screen	X	X	X
37	7002-008	3" Bird Screen	X	X	X
38	5452-005-6000	Vinyl Drain Hose	X	X	X
*39	8620-031	Condensate Neutralizer	X	X	X

*Not pictured.

DOWNFLOW
PARTSLIST
FABRICATED PARTS

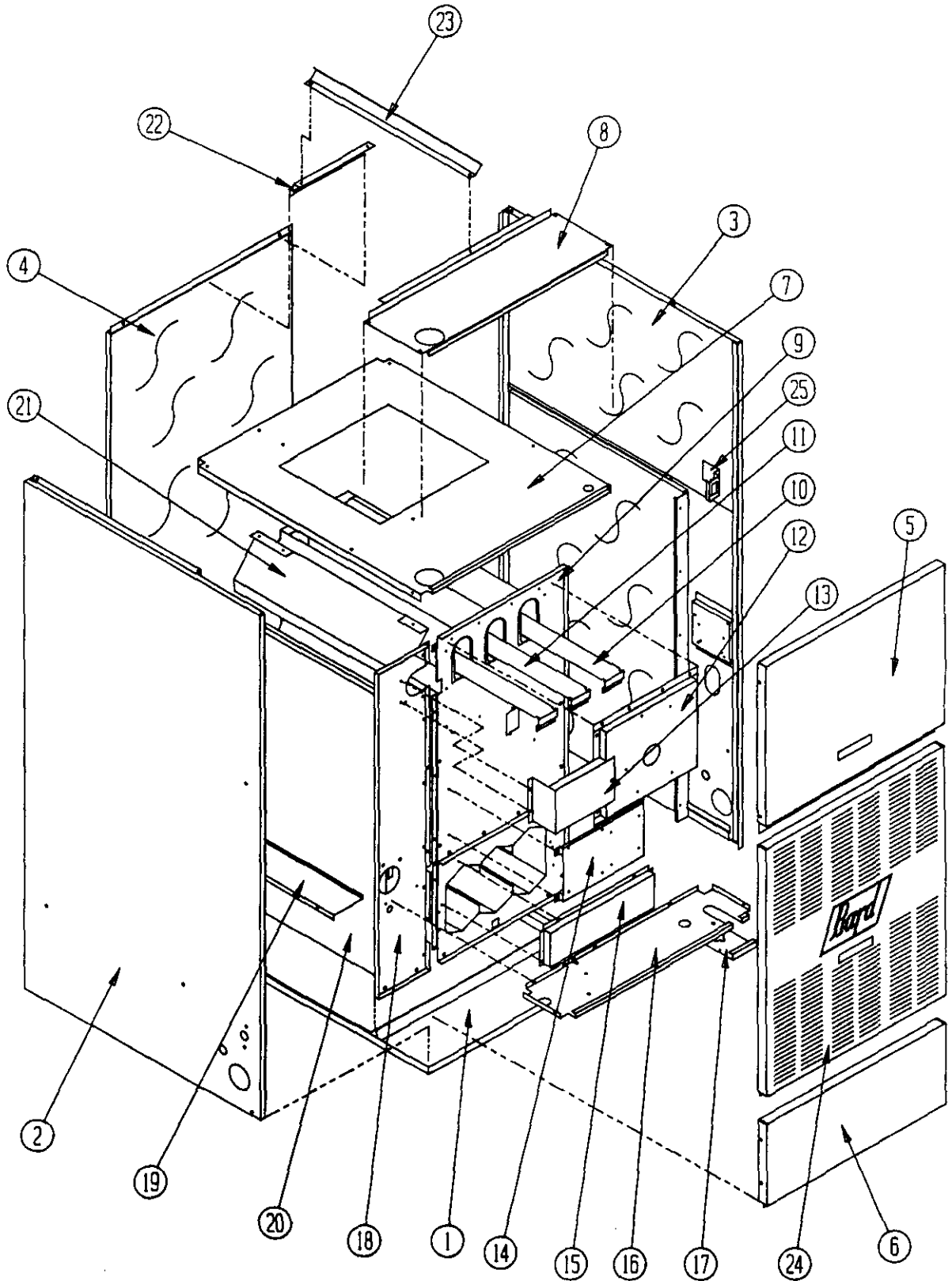

DOWNFLOW
PARTS LIST
FABRICATED PARTS

Date: 06/05/89

Dwg. No.	Part No.	Description	C C O 6 0 D 3 6 A	C C O 8 0 D 4 8 A	C C 1 0 0 D 4 8 A
1	127-166	Lower Base Assembly	X		
1	127-167	Lower Base Assembly		X	
1	127-163	Lower Base Assembly			X
2	501-198	Left Side Assembly	X	X	X
3	501-197	Right Side Assembly	X	X	X
4	508-018	Back Assembly	X		
4	508-019	Back Assembly		X	
4	508-073	Back Assembly			X
5	552-171	Blower Door Assembly	X		
5	552-172	Blower Door Assembly		X	
5	552-173	Blower Door Assembly			X
6	552-165	Burner Door Assembly	X		
6	552-166	Burner Door Assembly		X	
6	552-167	Burner Door Assembly			X
7	127-160	Blower Base Assembly	X		
7	127-161	Blower Base Assembly		X	
7	127-162	Blower Base Assembly			X
8	106-119	Top Fill	X		
8	106-120	Top Fill		X	
8	106-121	Top Fill			X
9	171-162	Heat Exchanger Assembly	X		
9	171-163	Heat Exchanger Assembly		X	
9	171-164	Heat Exchanger Assembly			X
10	168-002	Internal Flue Baffle	2	2	2
11	168-013	Internal Flue Baffle		1	2
12	913-0039	Collector Box Assembly	X		
12	913-0048	Collector Box Assembly		X	
12	913-0050	Collector Box Assembly			X
13	169-034	Transition Assembly	X		
13	169-035	Transition Assembly		X	
13	169-036	Transition Assembly			X
14	112-088	Module Bracket	X		
14	112-089	Module Bracket		X	X
15	168-003	Secondary Air Baffle	X		
15	168-008	Secondary Air Baffle		X	
15	168-010	Secondary Air Baffle			X
16	120-120	Burner Compartment Partition	X		
16	120-121	Burner Compartment Partition		X	
16	120-122	Burner Compartment Partition			X
17	136-131	Manifold Fill Plate	X	X	

FBB/PARTSLIST/TEXTLIB

DOWNFLOW
PARTS LIST
FABRICATED PARTS

Date: 06/05/89

Dwg. No.	Part No.	Description	C	C	C
			0	0	1
			6	8	0
			0	0	0
			D	D	D
			3	4	4
			6	8	8
			A	A	A
17	136-132	Manifold Fill Plate			X
18	520-119	Coil Partition	X	X	X
19	140-133	Coil Support	X	X	X
20	134-098	Internal Coil Partition	X	X	X
21	134-107	Coil Extension Partition	X	X	
22	130-023	Filter Support Bracket	X	X	X
23	130-062	Main Filter Support	X	X	X
24	152-168	Vestibule Door	X		
24	152-169	Vestibule Door		X	
24	152-170	Vestibule Door			X
25	112-094	Door Switch Bracket	X	X	X

FBS/PARTSLIST/TEXTLIB

DOWNFLOW
MECHANICAL PARTS

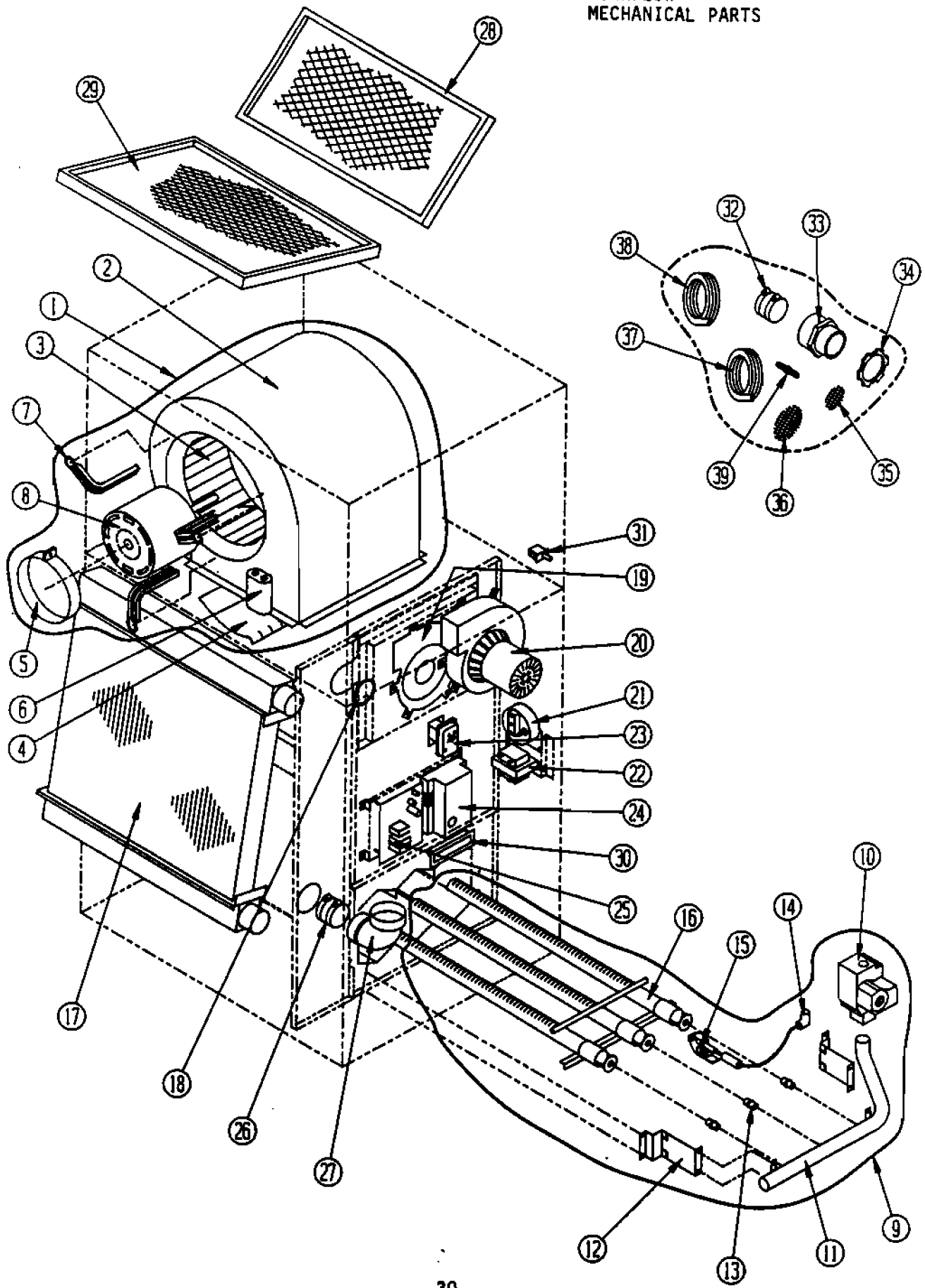

DOWNFLOW
PARTS LIST
MECHANICAL PARTS

Date: 06/05/89

Dwg. No.	Part No.	Description	C	C	C
			0	0	1
			6	8	0
			0	0	0
			D	D	D
			3	4	4
			6	8	8
			A	A	A
1	900-150	Blower Assembly	X		
1	900-151	Blower Assembly		X	
1	900-152	Blower Assembly			X
2	151-089	Blower Housing Assembly	X		
2	151-077	Blower Housing Assembly		X	
2	151-090	Blower Housing Assembly			X
3	5152-013	Blower Wheel	X		
3	5152-059	Blower Wheel		X	
3	5152-061	Blower Wheel			X
4	144-127	Diffuser	X		
4	144-129	Diffuser		X	
4	144-131	Diffuser			X
5	8200-033	Motor Mount Band	X	X	X
6	8552-002	Capacitor	X		
6	8552-004	Capacitor		X	
6	8552-006	Capacitor			X
7	8200-034	Motor Mount Arm	3	3	3
8	8105-008	Motor	X		
8	8106-018	Motor		X	
8	8107-004	Motor			X
9	901-0083	Burner Assembly	X		
9	901-0082	Burner Assembly		X	
9	901-0084	Burner Assembly			X
10	8554-009	Gas Valve	X	X	X
11	5818-019	Manifold 2 Section	X		
11	5818-020	Manifold 3 Section		X	
11	5818-021	Manifold 4 Section			X
12	112x095	Manifold Bracket	X	X	X
12	112y095	Manifold Bracket	X	X	X
13	9010-010	Gas Orifice #38	2		
13	9010-046	Gas Orifice #41		3	4
14	8600-008	Ignition Wire	X	X	X
15	8554-009	Pilot Assembly	X	X	X
16	9010-036	Burner 2 Section	X		
16	9010-037	Burner 3 Section		X	
16	9010-038	Burner 4 Section			X
17	5055-001	Coil Assembly	X	X	X
18	1921-020	Silicone Gasket	X	X	X
19	1921-019	IDB Gasket	X	X	X
20	8109-004	Induced Draft Blower	X	X	X

FB11/PARTSLIST/TEXTL1B

DOWNFLOW
PARTS LIST
MECHANICAL PARTS

Date: 06/05/89

Dwg. No.	Part No.	Description	C	C	C
			0	0	1
			6	8	0
			0	0	0
			D	D	D
			3	4	4
			6	8	8
			A	A	A
21	8406-042	Pressure Switch	X	X	
21	8406-041	Pressure Switch			X
22	8407-039	Transformer 40VA	X	X	X
23	8402-052	Limit Switch	X	X	X
24	5651-060	Ignition Module	X	X	X
25	8201-053	Blower Control	X	X	X
26	6093-007	"No-Hub" Connector	X	X	X
27	6095-005	Street Elb 90 degree	X	X	X
28	7003-001	Permanent Filter 10 x 20 x 1	2	1	1
29	7003-003	Permanent Filter 15 x 20 x 1		1	1
30	1171-025	Flush Door Pull	2	2	2
31	8406-013	Door Switch	X	X	X
32	6093-008	"No-Hub" Connector	X	X	X
33	6093-006	Male Adapter 2"	X	X	X
34	8611-063	2" Locknut	X	X	X
35	7002-009	2" Bird Screen	3	3	3
36	7002-008	3" Bird Screen		3	3
37	5452-005	Vinyl Tubing	X	X	X
38	5452-006	Silicone Tubing	X	X	X
39	6093-009	Hose Coupling	X	X	X

FH11/PARTSLIST/TEXTLIB

CONNECTION DIAGRAM

DANGER: ELECTRICAL SHOCK HAZARD.
DISCONNECT POWER BEFORE SERVICING.

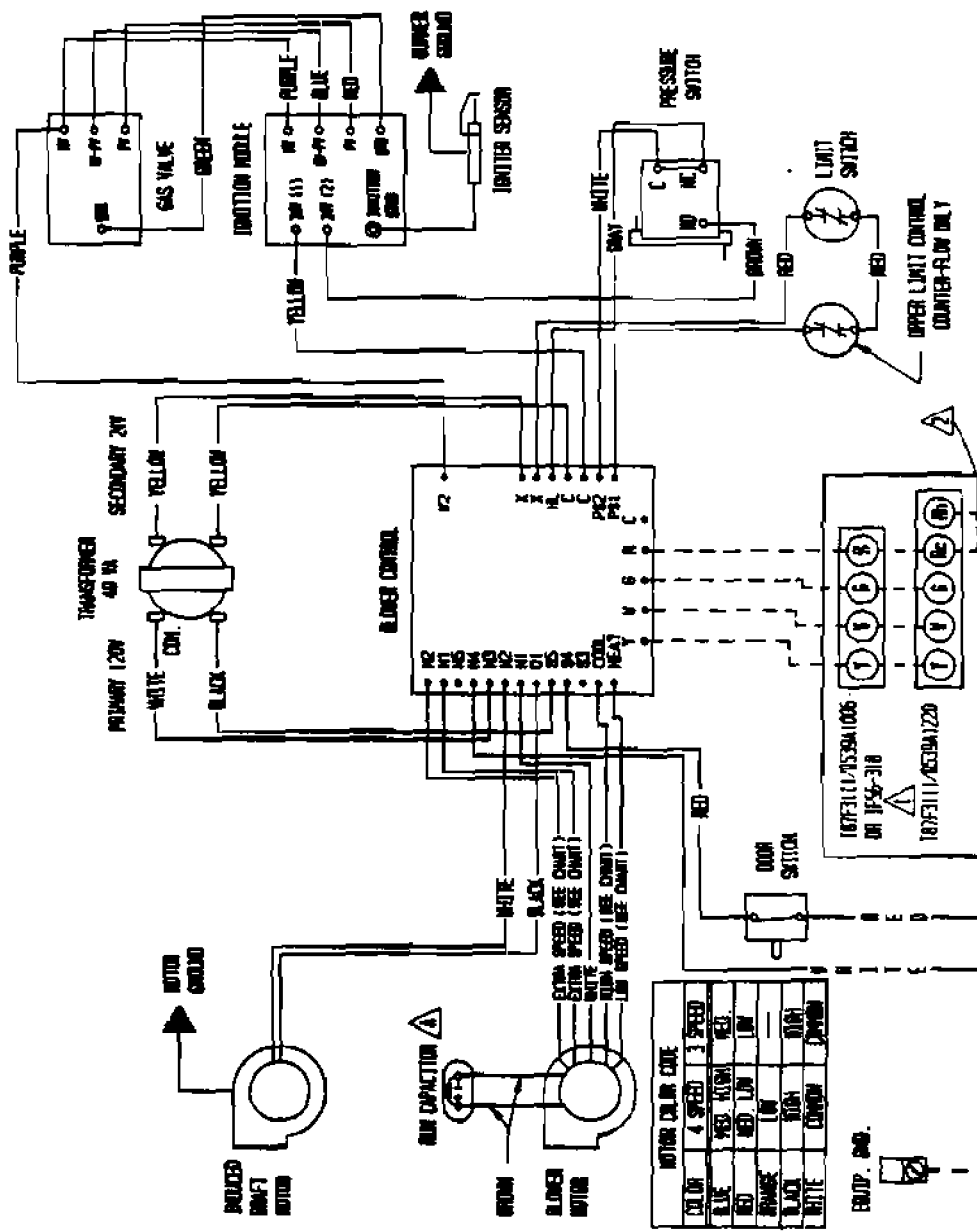

MODEL	RUN CAPACITOR
CC & CH680	5/370
CC & CH900	7.5/370
CC & CH180	15/370

WIRING	FIELD WIRING
USE COPPER CONDUCTORS ONLY	
Low Voltage	
High Voltage	

LADDER DIAGRAM

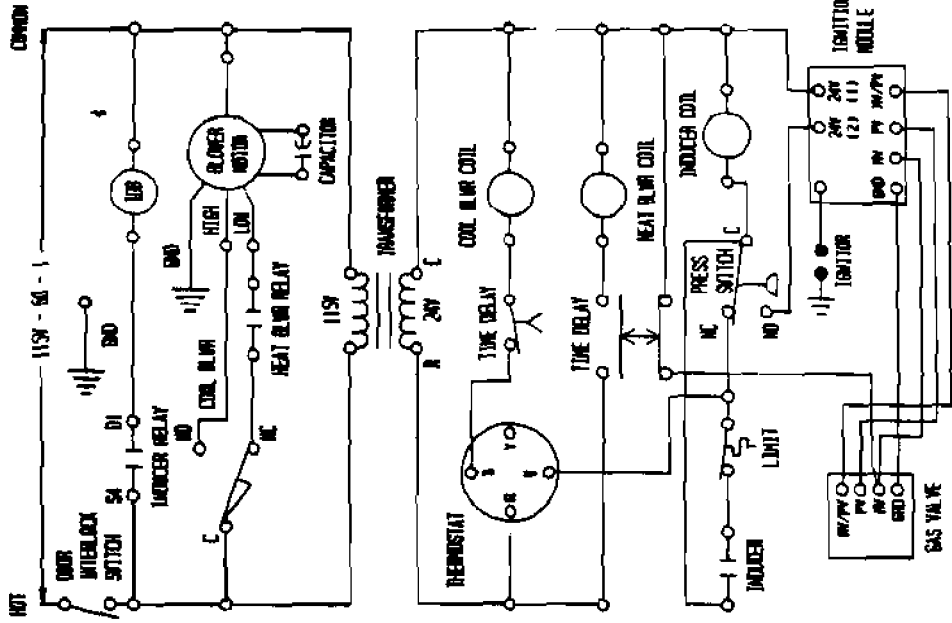

IF ANY OF THE ORIGINAL WIRE AS SUPPLIED WITH THE APPLIANCE MUST BE REPLACED, IT MUST BE REPLACED WITH WIRING MATERIAL HAVING A TEMPERATURE RATING OF AT LEAST 105 DEG C. EXCEPT THE IGNITION CABLE WHICH IS 250 DEG C. HIGH VOLTAGE CABLE.