

HIGH EFFICIENCY II GAS FURNACE USER'S INFORMATION MANUAL

FOR YOUR SAFETY

Do not store or use gasoline or other flammable vapors and liquids in the vicinity of this or any other appliance.

WARNING

Improper installation, adjustment, alteration, service or maintenance can cause injury or property damage. Refer to this manual. For assistance or additional information consult a qualified installer, service agency or the gas supplier.

FOR YOUR SAFETY WHAT TO DO IF YOU SMELL GAS

- *Do not try to light any appliance.
- *Do not touch any electrical switch; do not use any phone in your building.
- *Immediately call your gas supplier from a neighbor's phone. Follow the gas supplier's instructions.
- *If you cannot reach your gas supplier, call the fire department.

MANUAL 2100-151 REV. C
SUPERSEDES REV. B
FILE VOL. I, TAB 2

**COPYRIGHT APRIL, 1989
BARD MANUFACTURING COMPANY
BRYAN, OHIO**

GENERAL

The warnings shown on the cover of this manual and the information on the following pages are very important and should be fully read and understood by the operator of this equipment. Please take the few minutes necessary to completely read this booklet, and if there are any questions when you are through, ask your installer to review them with you. Please retain this booklet for future reference.

CLEARANCES

There are certain minimum installation clearances from the unit cabinet and sheet metal plenum attached to the unit to any combustible materials. These clearances for each model are shown on the furnace rating plate (located in the burner compartment) and are the responsibility of the installer during the installation of the appliance.

It is the user's responsibility to make sure these clearances are always maintained thereafter. Additionally, a minimum of 24 inches for serviceability of furnace is required from the front side of all models.

A furnace installed in an attic or other insulated space must be kept free and clear of insulating material. The furnace area should be examined when the furnace is installed or when any additional insulation is added. Some insulating materials may be combustible.

BE SURE TO OBSERVE THE FOLLOWING RULES:

- A. DO NOT allow any cardboard, newspapers, or any other combustible material (this includes wood, 2x4's, etc.) within the above specified minimum clearances. This includes placing any combustibles on or against the sheet metal plenum attached to the unit.
- B. DO NOT use this furnace if any part has been under water. Immediately call a qualified service technician to inspect the unit and to replace any part of the control system and any gas control which has been under water.
- C. The furnace area is to be kept clear and free of combustible materials, solvents, painting supplies, and any other flammable vapors or liquids.

COMBUSTION AND VENTILATING AIR

Whether your furnace is installed in a closet, basement, garage or other location as dictated by the particular application, an adequate source of fresh outside air has been provided by the installer to allow proper combustion and venting of the products of combustion to the outside of the building.

It is again the responsibility of the user to assure that this important flow of combustion and ventilating air is not obstructed from reaching the furnace.

Do not block or obstruct air openings on the furnace, air openings communicating with the area in which the furnace is installed, and the spacings around the furnace.

LIGHTING AND SHUTDOWN INSTRUCTIONS

WARNING

Should overheating occur, or the gas supply fail to shut off, shut off the manual gas valve to the unit before shutting off the electrical supply.

FOR YOUR SAFETY READ BEFORE OPERATING

WARNING: If you do not follow these instructions exactly, a fire or explosion may result causing property damage, personal injury or loss of life.

- A. This appliance is equipped with an Ignition device which automatically lights the pilot. Do not try to light the pilot by hand.
- B. BEFORE OPERATING smell all around the appliance area for gas. Be sure to smell next to the floor because some gas is heavier than air and will settle on the floor.
- WHAT TO DO IF YOU SMELL GAS**
- Do not try to light any appliance.
 - Do not touch any electric switch; do not use any phone in your building.
 - Immediately call your gas supplier from a neighbor's phone. Follow the gas supplier's instructions.
- If you cannot reach your gas supplier, call the fire department.
- C. Use only your hand to push in or turn the gas control knob. Never use tools. If the knob will not push in or turn by hand, don't try to repair it, call a qualified service technician. Force or attempted repair may result in a fire or explosion.
- D. Do not use this appliance if any part has been under water. Immediately call a qualified service technician to inspect the appliance and to replace any part of the control system and any gas control which has been under water.

OPERATING INSTRUCTIONS

1. STOP! Read the safety information above on this label.
 2. Set the thermostat to lowest setting.
 3. Turn off all electric power to the appliance.
 4. This appliance is equipped with an Ignition device which automatically lights the pilot. Do not try to light the pilot by hand.
 5. Remove control access panel.
 6. Push in gas control knob slightly and turn clockwise to "OFF."
- NOTE: Knob cannot be turned to "OFF" unless knob is pushed in slightly. Do not force.
7. Wait five (5) minutes to clear out any gas. If you then smell gas, STOP! Follow "B" in the safety information above on this label. If you don't smell gas, go to next step.
 8. Turn gas control knob counterclockwise to "ON."
 9. Replace control access panel.
 10. Turn on all electric power to the appliance.
 11. Set thermostat to desired setting.
 12. If the appliance will not operate, follow the instructions "To Turn Off Gas To Appliance" and call your service technician or gas supplier.

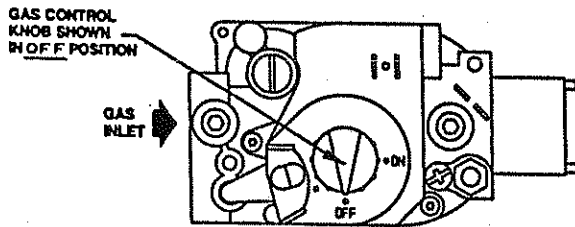

TO TURN OFF GAS TO APPLIANCE

1. Set the thermostat to lowest setting.
2. Turn off all electric power to the appliance if service is to be performed.
3. Remove control access panel.
4. Push in gas control knob slightly and turn clockwise to "OFF." Do not force.
5. Replace control access panel.

7981-219

AIR FILTERS

It is the user's responsibility to check the condition of the air filters on at least a monthly basis when the unit is in use and to clean or replace whenever it is necessary.

Permanent Type Filter (usually foam type) are washable. Use a solution of soapy water, followed by a rinse in clear water and then dried by tapping the frame against a solid object.

NEVER OPERATE A FURNACE WITHOUT A FILTER

NEVER SUBSTITUTE A THROWAWAY (FIBERGLASS) FOR A PERMANENT (FOAM) TYPE

Filter Size for Gas furnace	
Model	Size
CH060D36B	1 - 16x25x1
CC060D36A	2 - 10x20x1
CH080D48B	1 - 16x25x1
CC080D48A	1 - 10x20x1, 1 - 15x20x1
*CH100D60B	1 - 16x25x1
CC100D48A	1 - 10x20x1 1 - 15x20x1

*2-16x25x1 for 5 tons of cooling.

FILTER LOCATIONS--REMOVAL AND REPLACEMENT PROCEDURES--ALL HI-BOY FURNACES--

To remove filters from ALL sectional Hi-Boys, remove the lower blower compartment door by grasping the handle and pull up and away from the furnace. Then, remove the "S" clip and spring by pulling the clip towards the front of the furnace.

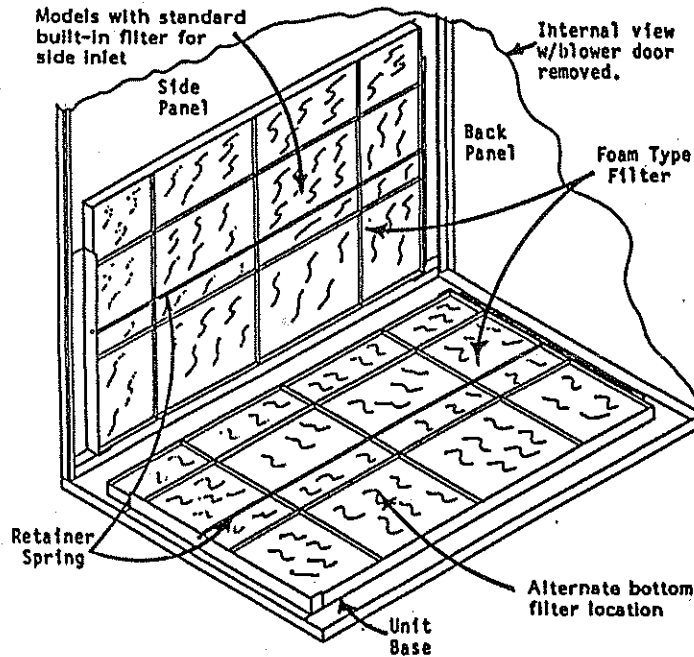

ALTERNATE BOTTOM FILTER LOCATION

All Hi-Boy models have an alternate bottom filter location as a standard feature to meet different installation requirements. See preceding illustration.

ALTERNATE SIDE FILTER RACK

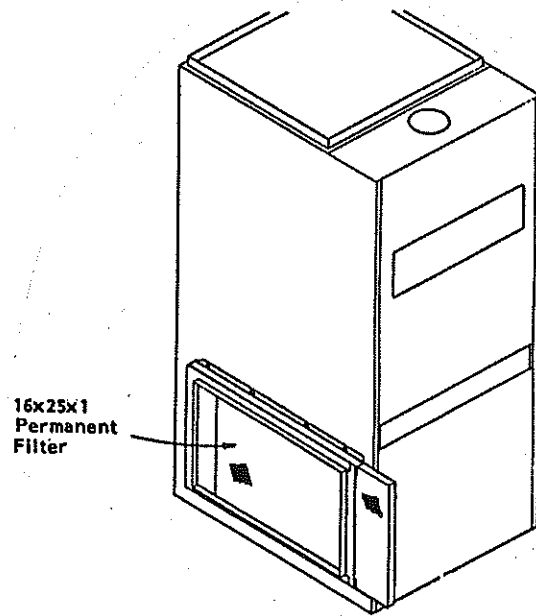

To remove filter from the optional external filter rack, grasp the exposed end of the filter and pull from the filter rack.

The location may vary, depending on which side the installer located the return air duct.

This filter is the permanent high velocity type foam filter which may be washed and used over and over. DO NOT replace it with a fiberglass filter of the same size.

To replace filter, reverse the above process.

FILTER LOCATIONS--COUNTERFLOW MODELS

Counterflow models normally have filters installed in the return air plenum above the furnace unless a common return air/filter grille is used. Refer to figures 10A and 10B for suggested filter locations.

FIGURE 10A

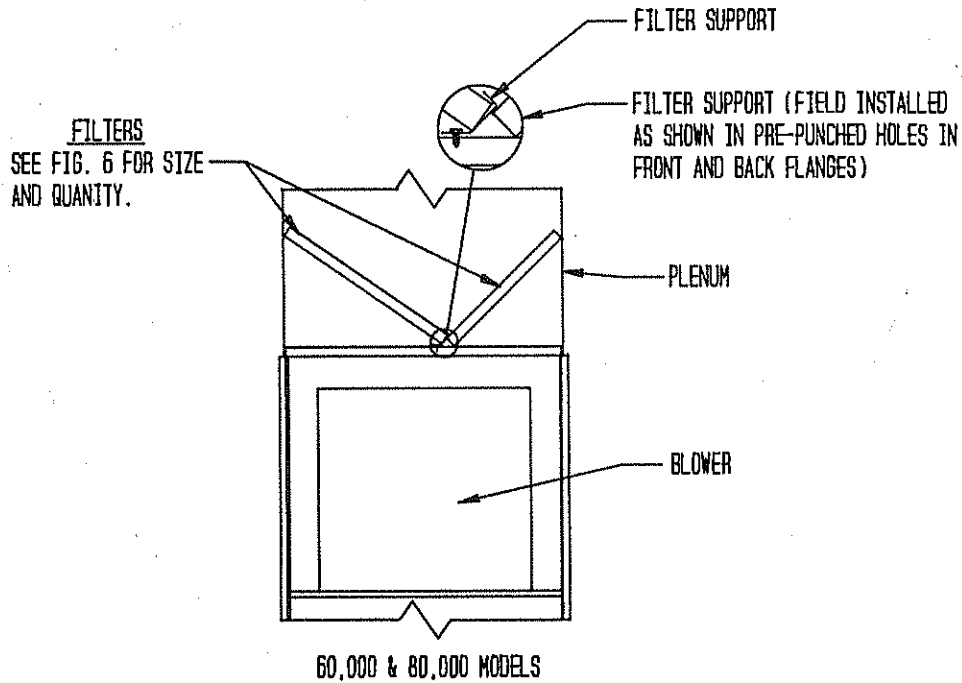
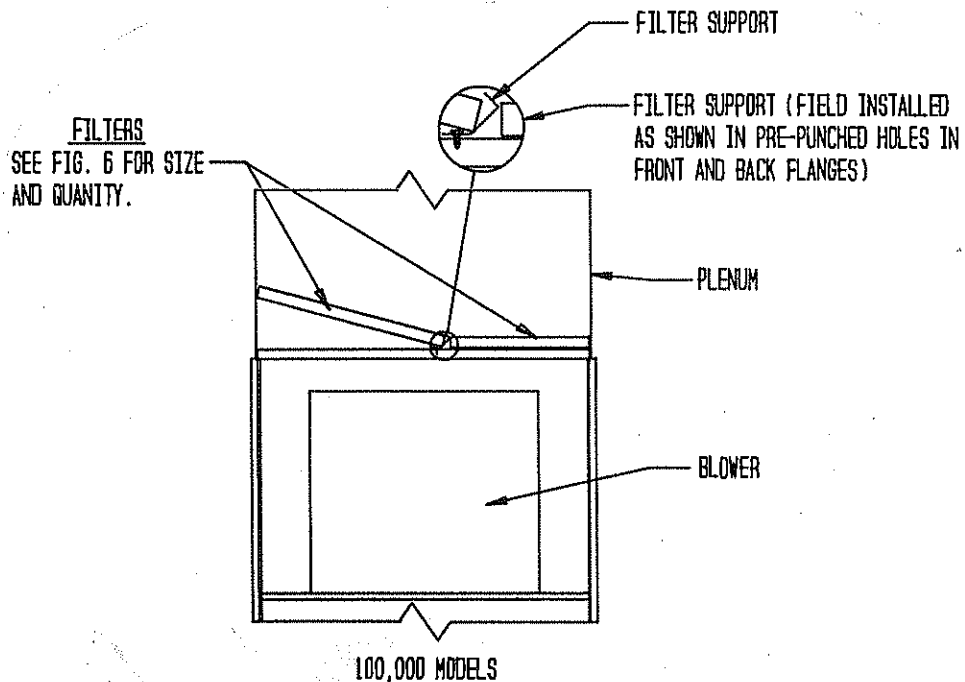

FIGURE 10B



LUBRICATION REQUIREMENTS

All models have permanently lubricated blower motors. The induced draft blower motor must be lubricated every six months with 3 to 4 drops of SAE20 motor oil.

FURNACE EXAMINATION

The furnace and the vent system (commonly called the flue pipe, smoke pipe, chimney, etc.) should be inspected yearly by a qualified service agency, generally prior to the heating season. Detailed procedures for this inspection are contained in the instructions booklet and should be handled by the qualified service agency only.

A general inspection of the furnace, the furnace area, and the venting system should be conducted on a regular basis by the owner/occupant. This review should include:

1. Assure that all flue product carrying areas external to the furnace (chimney, metal vent pipe, etc.) are clear and free of obstructions.
2. Make sure the furnace always has the minimum clearance as detailed on the furnace rating plate. Special attention must be given to these items if any remodeling is done.
3. Make sure the vent connector (system) is in place, slopes upward and is physically sound without holes, sags or dips.
4. Reviewing that the return air duct connection(s) is physically sound, is sealed to the furnace casing, and terminates outside the space containing the furnace.
5. The physical support of the furnace is sound without sagging, cracks, gaps, etc. around the base.
6. Inspect for any obvious signs of deterioration of the furnace.
7. The condensate drain must be inspected monthly for any blockage. If drain appears dirty or clogged, it must be removed and thoroughly washed out with warm water. Blockage of the drain can result in furnace malfunction.

Periodic examinations of the combustion area and vent system should also be conducted by the owner on a regular basis, preferably every month but at least every two months, during the heating season.

8. Check both the inlet and outlet terminals for any blockage. If blockage is present, remove the bird screens and clean them.

The following procedure should be followed for the periodic inspection as conducted by the owner:

1. Set the wall thermostat to the "off" position or lower the set point lever to a temperature well below the existing room temperature. Shut off electric power to the furnace. A switch should be mounted either on the outside of the furnace or adjacent to the furnace for this purpose.
2. Remove the furnace door exposing the burner compartment.
3. Using flashlight or trouble light, observe the burner compartment and where the burner(s) extend into the heat exchanger. There should be very minimal scaling or sooting in this area. Some loose debris may have fallen down on to the floor of the heat exchanger from the upper flue passageways, and this may be vacuumed out. Also observe the sides of the heat exchanger for "hot spots" due to improper burner alignment or overfiring and give particular attention to any area where it looks like there may be any

deterioration from corrosion or rusting. Observe for any corrosion on the burner themselves. Should anything appear questionable, contact your service agency.

4. Inspect the vent pipe the full distance from the furnace to the exit point from the building, observing for any possible leakage that might result in products of combustion entering the living area.

WARNING

LEAKAGE OF PRODUCTS OF
COMBUSTION INTO THE LIVING AREA
MAY RESULT IN ASPHYXIATION.

Any questionable vent pipe should be replaced. Considering its importance, it is relatively cheap insurance to protect your family. Consult your service agency.

6. Restore the electrical power to the furnace by turning the switch back on. Adjust the thermostat to call for heating operation.
7. Observe the main burners in operation. The flame should be mostly "blue" with possibly a little "orange" at the tips of the flames. The flames should be in the center of the heat exchanger compartments and not impinging on the heat exchanger surfaces themselves.
8. Observe the fire until the blower starts (there is a normal delay period until the heat exchanger warms up). There should be no change in the size or shape of the flame. If there is any wavering or blowing of the flame on the blower start-up, it is an indication of a possible leak in the heat exchanger. Turn off the main electrical switch to the furnace and the gas valve in the gas line leading to the furnace, and call you service agency.
9. The pilot flame can be adjusted by removing the pilot adjustment cover screw. Turn inner adjustment screw clockwise to decrease and counterclockwise to increase pilot flame. Be sure to replace cover screw after adjustment to prevent possible gas leakage.
10. Replace the burner compartment access doors by reversing the procedure as outlined under step 2 above.

