

INSTALLATION INSTRUCTIONS

SPLIT HEAT PUMP OUTDOOR SECTION

MODELS

24UHPQA
30UHPQA
36UHPQA

8° S.H. ADJUSTABLE

**FOR USE WITH:
MATCHING INDOOR BLOWER
COIL UNITS AND MATCHING
ADD ON COIL UNITS ONLY**

COPYRIGHT FEBRUARY, 1989
BARD MANUFACTURING COMPANY
BRYAN, OHIO

INDEX

I.	Application and Installation Instructions	1
	General	1
	Shipping Damage	1
	Installation	1
	Location	1
	Wiring	1
	Pressure Service Ports	2
	Fan Blade Setting Dimensions	2
	Indoor Coil	2
	Setting The Unit	3
	Slab Mounting	3
	Roof Mounting	3
	Winter Installation Below 32 Degree F	3
	Refrigerant Charge	6
	Sequence of Operation	6
	Thermostat Indicator Lamp	7
	Emergency Heat Position	7
	Compressor Malfunction Relay (1-Ph Models Only)	7
	Defrost Cycle	7
	Crankcase Heaters	8
	Important Installer Note	9
	Service Hints	9
	Compressor Cut-Off Thermostat and Outdoor Thermostat	10
	Compressor Cut-Off Thermostat Wiring	10
II.	Installing Refrigerant Tubing	12

INDEX OF FIGURES AND TABLES

Figure 1	1
Figure 2	4
Figure 3	8
Figure 4	9
Figure 5	10
Figure 6	11
Figure 7	11
Figure 8	11
Figure 9	11
Figure 10	13

Table 1	1
Table 2	2
Table 3	5
Table 4	6
Table 5	7
Table 6	14
Table 7	15
Table 8	15
Table 9	20
Table 10	20
Table 11	21
Table 12	21
Table 13	22
Table 14	22

FIGURE 1

NOMENCLATURE EXPLANATION--Example:

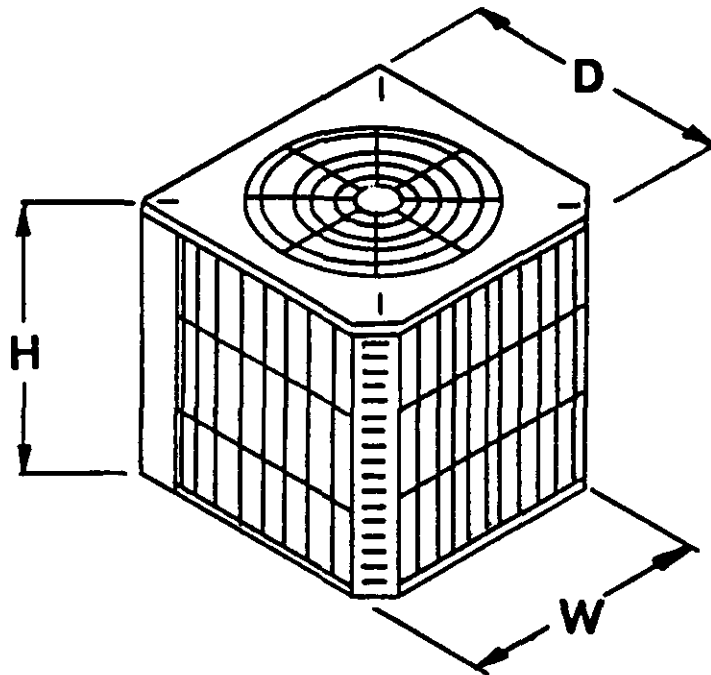
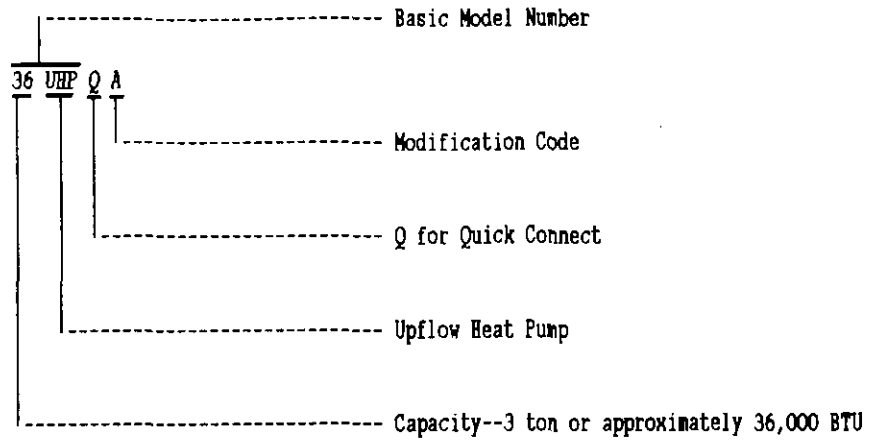

TABLE 1

DIMENSIONS			
Basic Model No.	"W" Width	"D" Depth	"H" Height
24UHPQA			
30UHPQA	32-1/2"	32-1/2"	26"
36UHPQA			

TABLE 2

RATED CFM AND AIRFLOW DATA (Wet Coil--Cooling)						
Condensing Unit Model Number	Evaporator Coil Model Number	Rated AirFlow		Rated E.S.P. (2)	Motor Speed Tap	Recommended Air Flow Range
		CFM	Pressure Drop H ₂ O (1)			
24URPQA	BC24B	800		.35	High	700 - 910
	A30AQ-A	800	.16			700 - 910
30URPQA	BC36B	1050		.30 3	Low	900 - 1150
	BC35B	975		.50 3	Low	825 - 1075
	A36AQ,S-A	1050	.20			900 - 1150
	A42AS,S-A	1050	.15			900 - 1150
36URPQA	BC36B	1200		.30 3	High	1020 - 1320
	BC35B	1125		.40 3	High	950 - 1240
	A36AQ,S-A	1200	.30			1020 - 1320
	A42AS,S-A	1200	.20			1020 - 1320

① Measured across the evaporator coil assembly, including drain pan.

② External static pressure available for the duct system--supply and return. All blower coils have multi-speed motors, and value shows is at the recommended rated speed. Consult specification airflow charts with the blower coil units for complete information at other speeds.

③ Add .05 ESP for side inlet return with FR6 filter rack.

APPLICATION AND INSTALLATION INSTRUCTIONS

GENERAL

These instructions explain the recommended method to install the air cooled remote type condensing unit, the interconnecting refrigerant tubing and the electrical wiring connections to the unit.

The condensing units are to be used in conjunction with the matching evaporator coils or evaporator blower units for comfort cooling/heating applications as shown in the specification sheet.

These instructions and any instructions packaged with any separate equipment required to make up the entire air conditioning system should be carefully read before beginning the installation. Note particularly "Connecting Quick-Connect Couplings, Starting Procedure" and any tags and/or labels attached to the equipment.

While these instructions are intended as a general recommended guide, they do not supersede any national and/or local codes in any way. Authorities having jurisdiction should be consulted before the installation is made.

SHIPPING DAMAGE

Upon receipt of equipment, the carton should be checked for external signs of shipping damage. If damage is found, the receiving party must contact the last carrier immediately, preferably in writing, requesting inspection by the carrier's agent.

INSTALLATION

Size of unit for a proposed installation should be based on heat loss calculation made according to methods of National Warm Air Heating and Air Conditioning Association. The air duct should be installed in accordance with the Standards of the National Fire Protection Association for the Installation of Air Conditioning and Ventilating Systems of Other Than Residence Type, NFPA No. 90A and Residence Type Warm Air Heating and Air Conditioning Systems, NFPA No. 90B. Where local regulations are at a variance with instructions, installer should adhere to local codes.

LOCATION

The condensing unit is designed to be located outside with free and unobstructed condenser air inlet and discharge. It must also permit access for service and installation. Condenser air enters the coil on three sides and discharges upward from the top. Refrigerant and electrical connections are made from the rear of the unit as shown in Figure 7 with electrical service access on the right side. The unit can be installed with the rear of the unit "close to the wall", however, additional service clearance at the back of the unit would be desirable if practical for unit service. The compressor can be serviced through the top.

WIRING

All wiring must be installed in accordance with the national Electrical Code and local codes. Power supply voltage must conform to the voltage shown on the unit serial plate. A wiring diagram of the unit is attached to the inside of the electrical cover. The power supply shall be sized and fused according to the specifications supplied. A ground lug is supplied in the control compartment for equipment ground.

The control circuit is a 24 volt circuit. "Typical" wiring diagrams illustrating some of the various circuits which could be encountered can be found later in the manual.

The unit rating plate lists a "Maximum Time Delay Fuse" or "HACR Type" circuit breaker that is to be used with the equipment. The correct size must be used for proper circuit protection and also to assure that there will

be no nuisance tripping due to the momentary high starting current of the compressor motor.

When matching with a B-model blower coil unit, refer to the installation instructions with that indoor unit for 24V wiring information.

PRESSURE SERVICE PORTS

High and low pressure service ports are installed on all units so that the system operating pressures can be observed. Pressure tables can be found later in the manual covering all models. It is imperative to match the correct pressure table to the unit by model number.

The pressure service ports on the split system heat pump are located on the interconnecting tubing quick connect fittings. An additional low side service port is located on the quick connect mounting plate for low side pressure during heating operation.

FAN BLADE SETTING DIMENSIONS

Shown in the drawing below are the correct fan blade setting dimensions for proper air delivery across the outdoor coil.

Any service work requiring removal or adjustment in the fan and/or motor area will require that the dimensions below be checked and blade adjusted in or out on the motor shaft accordingly.

FIGURE 2

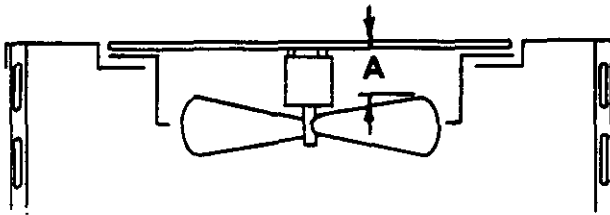

Model	Dimension A
24, 30, 36 UHP	3-1/2

INDOOR COIL

These units are designed to match with all indoor blower coils, horizontal coils and "A" coils shown earlier in these instructions. Some blower and all horizontal coils are produced with capillary tube type refrigerant control. All "A" coils and some blower coils shown are produced with an interchangeable brass orifice to provide optimum matching of the refrigerant control when matching alternate sized indoor units to the outdoor unit. A properly sized orifice for each outdoor section is packaged with this unit. See installation instructions packaged with the indoor section for complete details.

**TABLE 3
ELECTRICAL DATA**

MODEL	24UHPQA	30UHPQA	36UHPQA
Electrical Rating (60HZ/V/PH)	230/208-1		
Operating Voltage Range	197 - 253		
Minimum Circuit Ampacity	17	20	24
+Field Wire Size	#12	#12	#10
++Delay Fuse Max. or Ckt. Bkr.	25	30	40
Total Unit Amps 230/208	11.4/13.1	14.5/17.4	16.4/18.6
COMPRESSOR			
Rated Load Amps 230/208	10.3/12.0	13.4/16.3	15.3/17.5
Branch Ckt. Selection Current	12.1	14.8	18
Lock Rotor Amps 230/208	57/57	76/76	83.5/83.5
FAN MOTOR AND COMPRESSOR			
Fan Motor--HP/RPM	1/6 - 825		
Fan Motor--Amps	1.1		
Fan--Dia/CFM	24" - 3000		
+ 60 degree C copper wire size.			
++ Maximum time delay fuse or HACR type circuit breaker.			

SETTING THE UNIT

GENERAL--The unit must be located outside, or in a well ventilated area. It must not be in the space being heated or cooled. A sound absorbing material should be considered if the unit is to be installed in such a position or location that might cause transmission of sound or vibration to the living area or adjacent buildings.

SLAB MOUNTING

In areas where winter temperatures DO NOT go below 32 degrees F for periods over twelve hours, the unit may be slab mounted at grade level. When installing the unit at grade level, install on a concrete slab at least four inches above finished grade level. Slab should have a slope tolerance away from the building structure of at least 1/4 inch per foot, while being level from side to side. This will prevent ice buildup under the unit during defrost cycles. Place slab in a location where run-off water from higher ground will not collect around unit. See Figure 6.

A minimum clearance should be provided between the coil inlet and any building surfaces. Provide at least four feet between coil outlet and any structures. Provide a minimum of 8 inches clearance on the service access side of the unit. Refer to Figure 7.

ROOF MOUNTING

When a unit is installed in areas where low ambient temperatures or strong winter winds exist, it should be placed so prevailing winter winds are not in direct line with the heat pump coil. If this is not possible, a wind barrier should be constructed. Place barrier 24 inches from the coil side of the unit and in the direction of the prevailing winds. Size barrier at least the same height and 6 to 12 inches wider than unit. See Figure 8.

WINTER INSTALLATION BELOW 32 DEGREES F

In areas where winter conditions go below 32 degrees F for extended periods, the unit must be elevated above the mounting surface to prevent snowfall or defrost ice accumulation from interfering with the operation of the

unit. A minimum of twelve inch elevation is recommended, while greater elevation may be required for areas of high snow accumulation. Poured concrete, steel framework, brick, cement block, etc. can be utilized to construct a suitable raised mounting platform. See Figure 9. The mounting platform must provide support on all 5 dimples located on the unit base and must not rest against the unit base.

REFRIGERANT CHARGE

The correct system R-22 is shown on the unit rating plate. Optimum unit performance will occur with a refrigerant charge resulting in a suction line temperature (6" from compressor) as shown in the following table:

TABLE 4

Models	Rated Airflow	95 Degrees F O.D. Temp.	82 Degrees F O.D. Temp
24UHPQA/BC24B	800	58 - 60	72 - 74
24UHPQA/A30AQ, S-A	800	52 - 54	66 - 68
30UHPQA/BC35B	975	54 - 56	70 - 72
30UHPQA/BC36B	1050	56 - 58	68 - 70
30UHPQA/A36AQ, S-A	1050	62 - 64	70 - 72
30UHPQA/A42AS, S-A	1050	59 - 61	68 - 70
36UHPQA/BC35B	1125	58 - 60	69 - 71
36UHPQA/BC36B	1200	60 - 62	67 - 69
36UHPQA/A36AQ, S-A	1200	59 - 61	68 - 70
36UHPQA/A42AS, S-A	1200	60 - 62	69 - 71

NOTE: The suction line temperatures are based upon 80 degrees F dry bulb/67 degrees F wet bulb (50% R.H.) temperature and rated air flow across the evaporator during cooling cycle.

SEQUENCE OF OPERATION

COOLING--Circuit R-Y makes at thermostat pulling in compressor contactor starting the compressor and outdoor motor. The G (indoor motor) circuit is automatically completed on any call for cooling operation, or can be energized by manual fan switch on subbase for constant air circulation.

HEATING--A 24V solenoid coil on reversing valve controls heating cycle operation. Two thermostat options, one allowing "Auto" changeover from cycle to cycle and the other constantly energizing solenoid coil during heating season and thus eliminating pressure equalization noise except during defrost, are to be used. On "Auto" option, a circuit is completed from R-W1 and R-Y on each heating "on" cycle, energizing reversing valve solenoid and pulling in compressor contactor starting compressor and outdoor motor. R-G also make starting indoor blower motor. Heat pump heating cycle is now in operation. The second option has no "Auto" changeover position, but instead energizes the reversing valve solenoid constantly whenever the system switch on subbase is placed in "heat" position, the "B" terminal being constantly energized from R. A thermostat demand for heat completes R-Y circuit, pulling in compressor contactor starting compressor and outdoor motor. R-G also make starting indoor blower motor.

TABLE 5

WALL THERMOSTAT AND SUBBASE COMBINATIONS			
Group	Thermostat	Subbase	Predominant Feature
A	8403-017 (T874R1129)	8404-009 (Q674L1181)	Heat or Cool ① No Auto
B	8403-018 (T874N1024)	8404-010 (Q674F1261)	Automatic Heat-Cool Changeover Position ②
<p>① No automatic changeover position--must manually place in heat or cool. Reversing valve remains energized at all times system switch is in heat position (except during defrost cycle). No pressure equalization noise when thermostat is satisfied on either heating or cooling.</p> <p>② Allows thermostat to control both heating and cooling operation when set in "Auto" position. Reversing valve de-energizes at end of each "On" heating cycle.</p>			

IMPORTANT NOTE: Both thermostat and subbase combinations shown above incorporate the following features: Man-Auto fan switch, Off-Heat-Cool-Em. Heat Switch, and two (2) indicator lamps--one for emergency heat and one for compressor malfunction.

THERMOSTAT INDICATOR LAMPS

The red lamp marked "EM.HT." comes on and stays on whenever the system switch is placed in the emergency heat position. The green lamp marked "check" will come on if there is any problem that prevents the compressor from running when it is supposed to be.

EMERGENCY HEAT POSITION

The operator of the equipment must manually place the system switch in this position. This is done when there is a known problem with the outdoor section, or when the green "check" lamp comes on indicating a problem.

COMPRESSOR MALFUNCTION RELAY (1-Ph Models Only)

Actuation of the green "check" lamp is accomplished by a voltage type relay which is factory installed. Any condition such as loss of charge, defective capacitor, defective contactor, etc., that will prevent compressor from operating will cause green lamp to activate. This is a signal to the operator of the equipment to place system in emergency heat position.

DEFROST CYCLE

The defrost cycle is controlled by time and temperature. The 24 volt solid state heat pump control runs only during heat pump operation.

When the outdoor temperature is in the lower 40 degree F temperature range or colder, the outdoor coil temperature is 32 degree F or below. This temperature is sensed by the coil sensor mounted near the bottom of the outdoor coil. The coil sensor sends a signal to the control logic of the heat pump control at approximately 32 degree F. Every 60 (90, or 30) minutes that the heat pump is running contacts on the heat pump control close for 10 minutes. If the coil sensor indicates that the coil is at 32 degree F or lower the defrost relay energizes and places the system in defrost mode.

During the defrost mode, the refrigerant cycle switches back to the cooling cycle, the outdoor motor stops, electric heaters are energized, and hot gas passing through the outdoor coil melts any accumulated frost. When the temperature rises to approximately 57 degrees F, the defrost thermostat opens, de-energizing the defrost relay and returning the system to heating operations automatically.

If some abnormal or temporary condition such as a high wind causes the heat pump to have a prolonged defrost cycle, the heat pump control will restore the system to heating operation automatically after 10 minutes.

There are three settings on the heat pump control--30 minute, 60 minute, and 90 minute. Most models are shipped wired on the 60 minute setting for greatest operating economy. If special circumstances require a change to another time, remove wire connected to terminal 60 and reconnect to desired terminal.

There is a cycle speed up jumper on the control. This can be used to reduce the time between defrost cycle operation without waiting for time to elapse.

There is an initial defrost jumper on the control that can be used at any outdoor ambient during the heating cycle to simulate a 0 degree coil temperature. This can be used to check defrost operation of the unit without waiting for the outdoor ambient to fall into the defrost region.

FIGURE 3

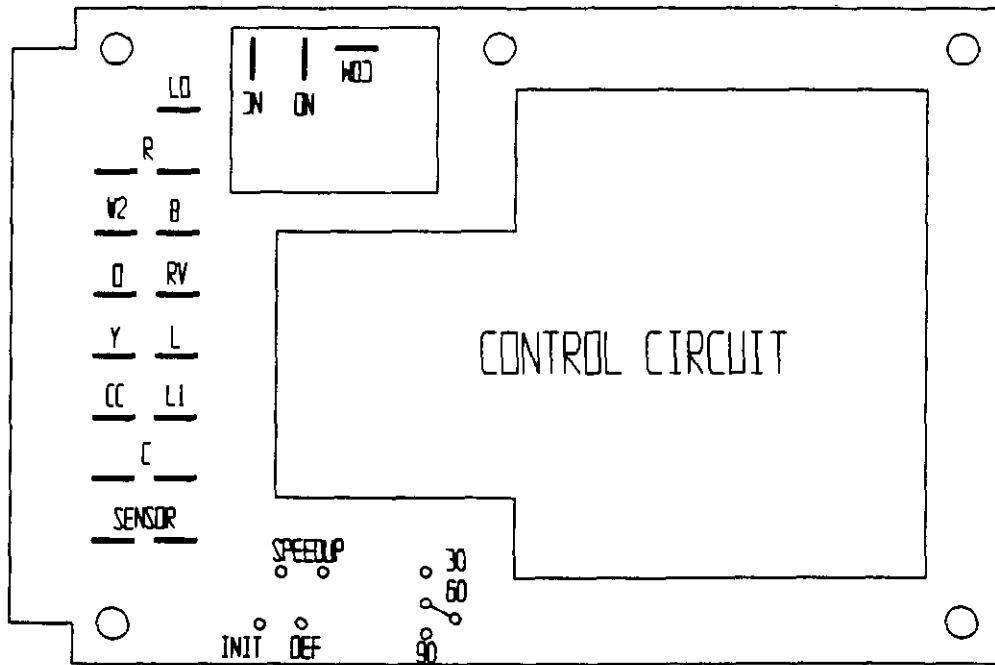

CRANKCASE HEATERS

All units are provided with some form of compressor crankcase heat. Some single phase units utilize the compressor motor start winding in series with a portion of the run capacitor to generate heat within the compressor shell to prevent liquid refrigerant migration.

Some three phase units utilize a wraparound type of crankcase heater that warms the compressor oil from the outside.

Some single and three phase models have an insertion well-type heater located in the lower section of the compressor housing. This is a self-regulating type heater that draws only enough power to maintain the compressor at a safe temperature.

Some form of crankcase heat is essential to prevent liquid refrigerant migrating to the compressor causing oil pump out on compressor start-up and possible valve failure due to compressing a liquid.

Refer to unit wiring diagram to find exact type of crankcase heater used.

The following decal is affixed to all outdoor units detailing start-up procedure. This is very important. Please read carefully.

FIGURE 4

IMPORTANT

THESE PROCEDURES MUST BE FOLLOWED AT INITIAL START-UP AND AT ANY TIME POWER HAS BEEN REMOVED FOR 12 HOURS OR LONGER.

TO PREVENT COMPRESSOR DAMAGE WHICH MAY RESULT FROM THE PRESENCE OF LIQUID REFRIGERANT IN THE COMPRESSOR CRANKCASE

1. MAKE CERTAIN THE ROOM THERMOSTAT IS IN THE "OFF" POSITION. (THE COMPRESSOR IS NOT TO OPERATE).
2. APPLY POWER BY CLOSING THE SYSTEM DISCONNECT SWITCH. THIS ENERGIZES THE COMPRESSOR HEATER WHICH EVAPORATES THE LIQUID REFRIGERANT IN THE CRANKCASE.
3. ALLOW 4 HOURS OR 60 MINUTES PER POUND OF REFRIGERANT IN THE SYSTEM AS NOTED ON THE UNIT RATING PLATE. WHICHEVER IS GREATER.
4. AFTER PROPERLY ELAPSED TIME THE THERMOSTAT MAY BE SET TO OPERATE THE COMPRESSOR.
5. EXCEPT AS REQUIRED FOR SAFETY WHILE SERVICING — DO NOT OPEN SYSTEM DISCONNECT SWITCH.

7961-061

IMPORTANT INSTALLER NOTE

For improved start-up performance, wash the indoor coil with a dishwasher detergent.

SERVICE HINTS

1. Caution homeowner to maintain clean air filters at all times. Also, not to needlessly close off supply and return air registers. This reduces air flow through the system, which shortens equipment service life as well as increasing operating costs.
2. Switching to heating cycle at 75 degrees F or higher outside temperature may cause a nuisance trip of the reset high pressure switch.
3. The heat pump wall thermostats perform multiple functions. Be sure that all function switches are

correctly set for the desired operating mode before trying to diagnose any reported service problems.

4. Check all power fuses or circuit breakers to be sure that they are the correct rating.
5. Periodic cleaning of the outdoor coil to permit full and unrestricted air flow circulation is essential.

COMPRESSOR CUT-OFF THERMOSTAT AND OUTDOOR THERMOSTAT

Heat pump compressor operation at outdoor temperatures below 0 degree F are neither desirable nor advantageous in terms of efficiency. Since most equipment at time of manufacture is not designated for any specific destination of the country, and most of the equipment is installed in areas not approaching the lower outdoor temperature range, the compressor cut-offs are not factory installed.

Outdoor thermostats are available to hold off various banks of electric heat until needed as determined by outdoor temperature. The set point of either type of thermostat is variable with geographic region and sizing of the heating equipment to the structure. Utilization of the Heating Application Data and the heat loss calculation of the building are useful in determining the correct set points.

COMPRESSOR CUT-OFF AND OUTDOOR THERMOSTAT WIRING

FIGURE 5

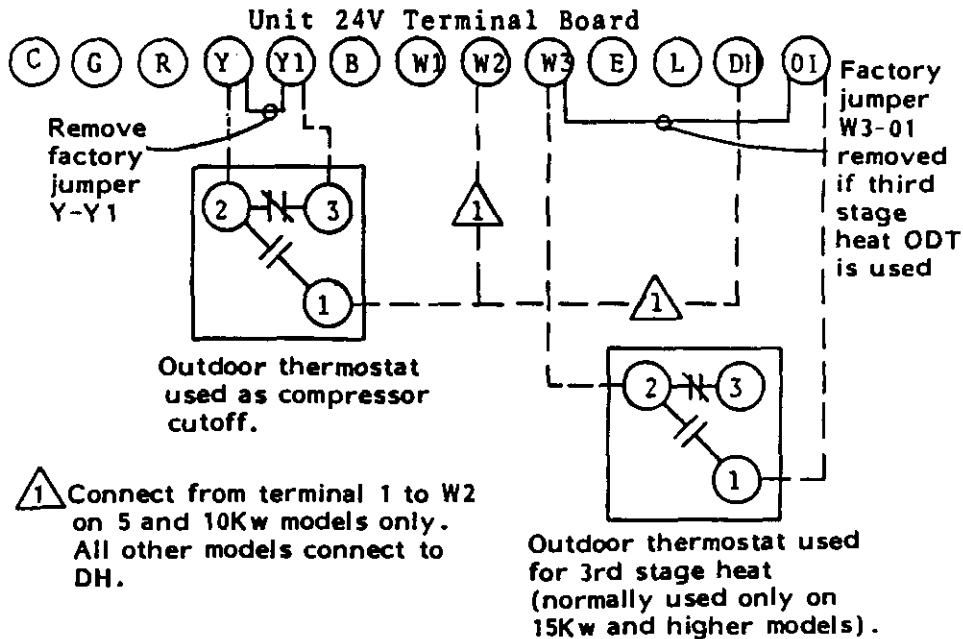

Figure 6

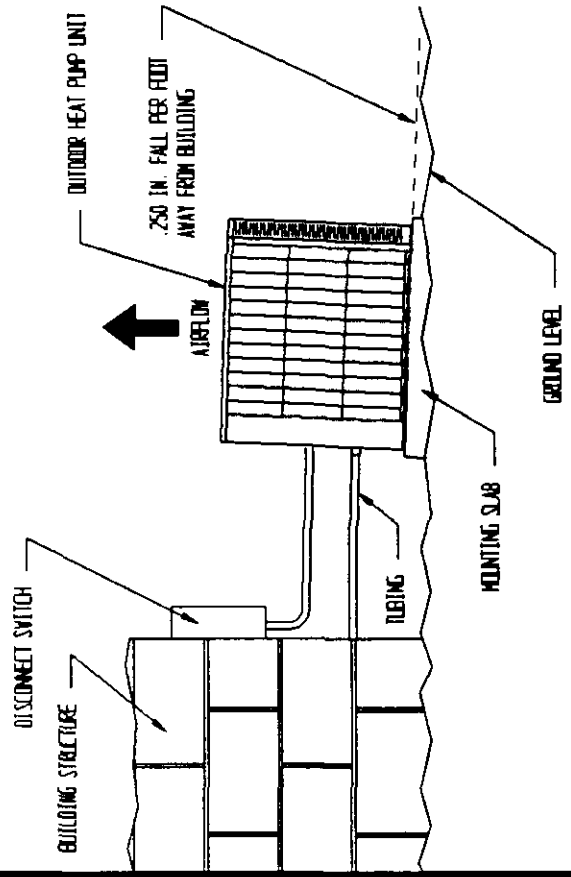

Figure 8

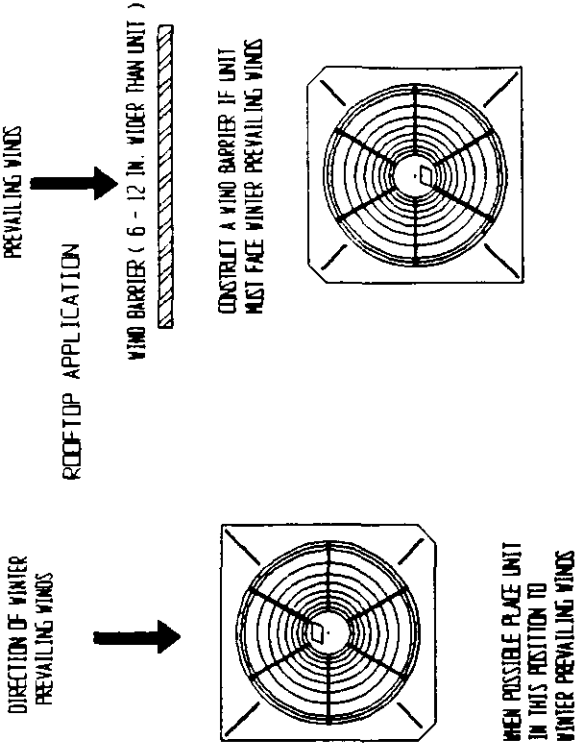

Figure 7

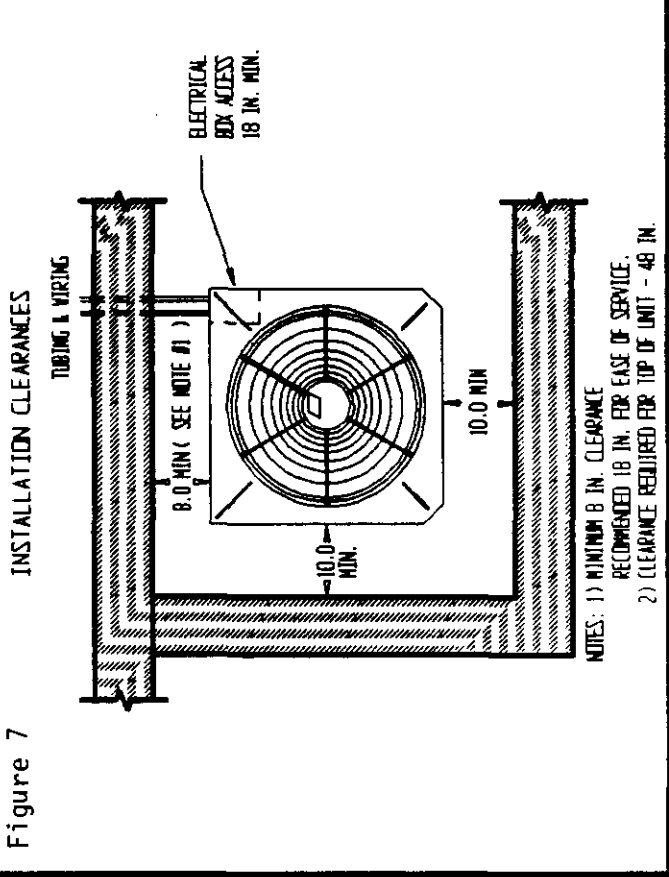
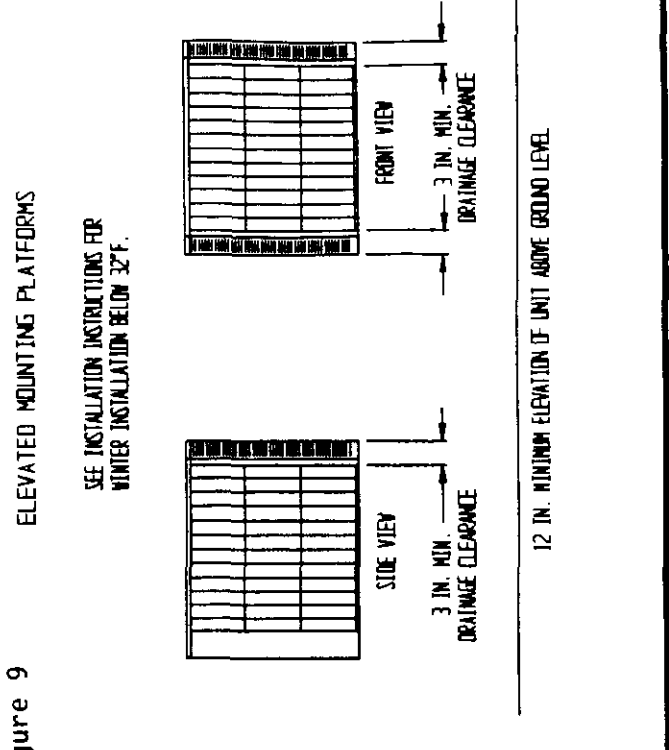

Figure 9



INSTALLING REFRIGERANT TUBING

PRECHARGED TUBING--Examine carefully the two lengths of precharged tubing furnished with the unit. The larger is the suction line. The smaller is the liquid line. The end of the tubing with the hex nut and gauge port is to be attached to the condensing unit.

Unroll the tubing, being careful not to kink, and install it between the condensing unit and the evaporator coil.

CAUTION: Be careful not to tear the insulation when pushing it through holes in masonry or frame walls.

When sealing tube opening in house wall, use a soft material to prevent tube damage and vibration transmission.

Before fastening either end, use a tubing bender to make any necessary bends in the tubing. AVOID EXCESSIVE BENDING IN ANY ONE PLACE TO AVOID KINKING.

Start connecting the tubing at the evaporator coil end, first remove the protective caps and plugs from the quick-connect fittings on the evaporator coil and the precharged tubing. Inspect fittings and clean if necessary making sure they are clear of foreign materials. If you clean the fittings, lubricate them with refrigeration oil. Connect both tubes to the fittings on the coil and draw up by hand.

When necessary to bend the insulated tube suction line, cut the insulation around its circumference at a distance far enough beyond the point of the bend so as to clear the tubing bender.

Slip the insulation back together and vapor seal the joint with tape.

NOTE: The maximum distance for precharge tubing between the condenser and the evaporator is 45 feet.

CAUTION: Prior to connecting the precharged tubing to the evaporator coil or condensing unit, be sure all bends have been made. Then coil any excess tubing in a horizontal place with the slope of the tubing toward the condensing unit.

CAUTION: Be sure to hold the coupling firmly to prevent movement of the coupling and tubing. Failure to do so could tear out the diaphragm causing a blockage of the system.

CAUTION: After starting to tighten up the fitting, never try to back it off or take it apart.

For connecting the tubing at the condensing unit end, first remove the protective caps and plugs from the quick-connect fittings on the condensing unit and the precharged tubing. Inspect fittings and clean if necessary, making sure they are clear of foreign materials. If you clean the fittings, lubricate them with refrigeration oil. Connect both tubes to the fittings on the coil and draw up by hand.

Locate the gauge port in a 45 degree angle from a vertical up position so as to be accessible for gauge connections.

Use a wrench on the hex nut of the female fitting backing up the fitting with another wrench to keep tube from turning. Tighten the fittings together until they bottom out then tighten for an additional 1/4 turn so that coupling will seat properly.

Check the gauge port cap to make sure it is tight. If loose, tighten, being careful not to tighten too much as it will damage the valve in the gauge port.

Leak test all connections using an Electronic Leak Detector or a Halide Torch.

**R22 TOTAL SYSTEM CHARGE FOR
SPLIT AIR CONDITIONING AND HEAT PUMP SYSTEMS**

The following tables are used to determine the operating charge for split air conditioning and heat pump systems. The values shown are the total amount of refrigerant received in the precharged system components, which include the outdoor unit, indoor unit, and inter-connecting tubing. This is also the amount of refrigerant required for a system recharge following any refrigeration system repairs.

Find the outdoor section and matching indoor section (Table 7) and connecting tubing set (Table 6) for system being used. Add the ounces of charge for each of the system components together. This value is the **TOTAL SYSTEM CHARGE**.

$$\begin{array}{r} \text{OZs} \\ \hline \text{OUTDOOR UNIT} \\ \text{(Table 7)} \end{array} + \begin{array}{r} \text{OZs} \\ \hline \text{INDOOR UNIT} \\ \text{(Table 7)} \end{array} + \begin{array}{r} \text{OZs} \\ \hline \text{TUBING SET} \\ \text{(Table 6)} \end{array} = \begin{array}{r} \text{OZs} \\ \hline \text{TOTAL SYSTEM CHARGE} \end{array}$$

To change total charge to lbs. and ozs., divide by 16.

EXAMPLE: 30UHPQA with BC36B and CT25A tubing set.

$$\begin{array}{r} \text{OZs} \\ \hline 84 \end{array} + \begin{array}{r} \text{OZs} \\ \hline 13 \end{array} + \begin{array}{r} \text{OZs} \\ \hline 8 \end{array} = \begin{array}{r} \text{OZs} \\ \hline 105 \end{array}$$

or $\frac{105}{16} = 6 \text{ lbs. } 9 \text{ ozs.}$

TABLE 6

CHARGED TUBING SETS				
Model	Charge	Length in Ft.	Liquid Line	Suction Line
FOR USE WITH: 24UHPQA, 30UHPQA, 36UHPQA				
CT0	None*	0	3/8"	3/4"
CT15A	2 oz.	15	3/8"	5/8"
CT25A	8 oz.	25	3/8"	3/4"
CT35A	14 oz.	35	3/8"	3/4"
CT45A	20 oz.	45	3/8"	3/4"

*CT0 and CT0-12 for field installed tubing. (See Table 7 for charging).

TABLE 7

Model	Outdoor Unit Factory Charge	For Use With Indoor Unit	Indoor Unit Factory Charge
24UHPQA	103 oz.	BC24B A30AQ-A	5 oz. 8 oz.
30UHPQA	84 oz.	BC36B BC35B A36AQ-A A42AS-A ①	13 oz. 8 oz. 8 oz. 0 oz.
36UHPQA	111 oz.	BC36B BC35B A36AQ-A A42AS-A ①	13 oz. 8 oz. 8 oz. 0 oz.

① Requires the use of CTO-12 kit for proper tubing connections on indoor coil.

In the event that the installer is running his own tubing by using a CTO kit, installing a sweat type A-coil or is modifying a precharged tubing set by adding or subtracting a few feet of tubing length, the tubing set should be evacuated and charged before being connected to the outdoor and indoor section. To determine TUBING SET ONLY charges, use the following table:

		TABLE 8 (Shows Charge in Ozs.)										
	Tubing Set Length in Ft.	10	15	20	25	30	35	40	45	50	55	60
RW Series	1/4" O.D. Liquid Line	2	2	3	3	5	7	9	11	--	--	--
CT Series	3/8" O.D. Liquid Line	2	2	5	8	11	14	17	20	23	26	29

To determine a TOTAL SYSTEM CHARGE for a system that is connected with a non-standard tubing length, the outdoor basic charge (from Table 7) plus the indoor unit basic charge (from Table 7), is added to the tube set based on liquid line O.D. size (Table 8). This value is the TOTAL SYSTEM CHARGE.

NOTE: If your tubing length is between the sizes shown in the table, use a charge value appropriately between the values shown for the tubing length shorter and longer than actual length.

LADDER DIAGRAM

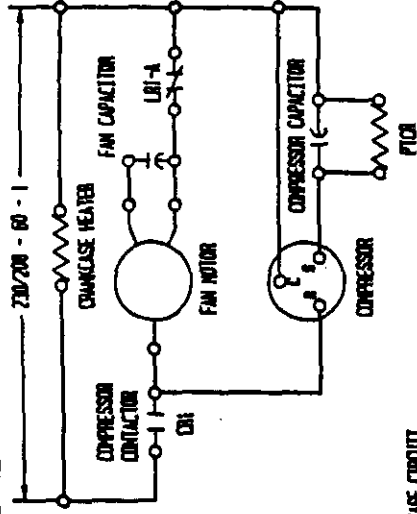

HIGH VOLTAGE CIRCUIT

LOW VOLTAGE CIRCUIT

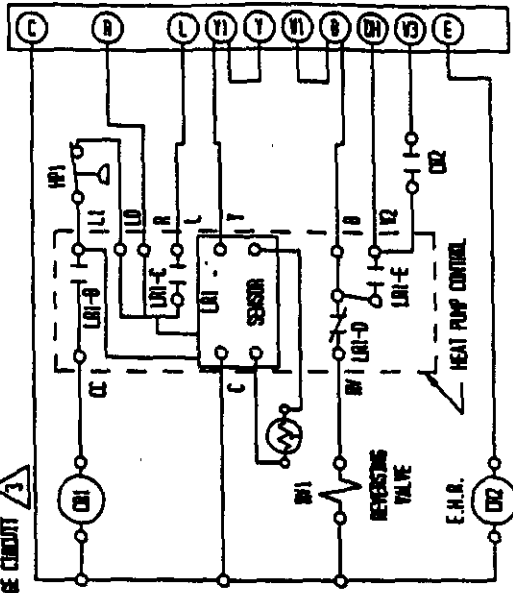

24 VOLTS FOR LOW VOLTAGE CONTROL CIRCUIT SUPPLIED BY 3000R UNIT TRANSFORMER

4086-110

CONNECTION DIAGRAM

DANGER: ELECTRICAL SHOCK HAZARD.
DISCONNECT POWER BEFORE SERVICING

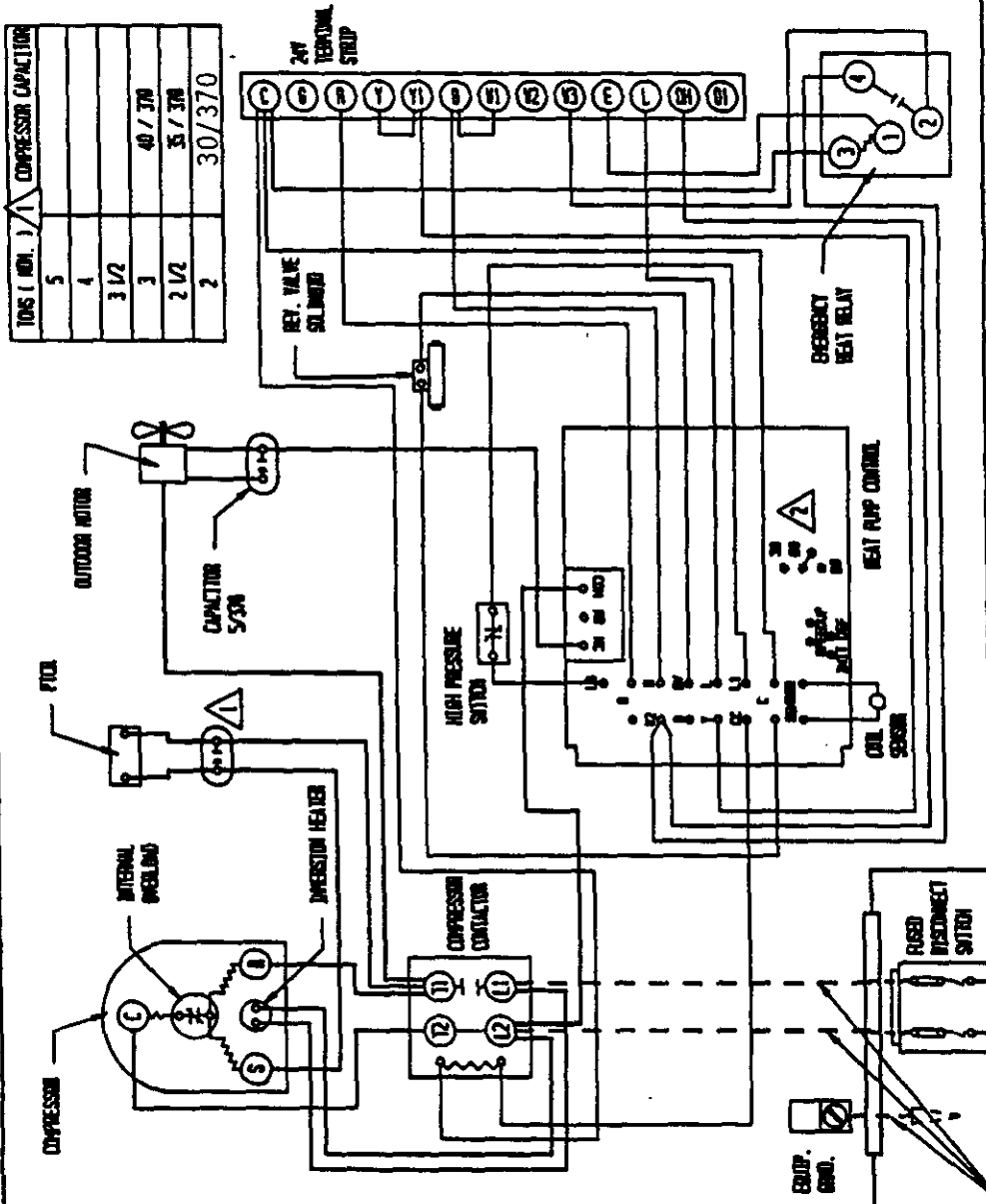

TONS (MIN.)	COMPRESSOR CAPACITOR
5	
4	
3 1/2	
3	40 / 370
2 1/2	35 / 370
2	30 / 370

FACTORY SET ON 60 MIN. CYCLE
RECONNECT TO 30 FOR 30 MIN. CYCLE
RECONNECT TO 90 FOR 90 MIN. CYCLE

FACTORY WIRING	FIELD WIRING
---	---

Low Voltage
High Voltage



	COOLING	HEATING	HEATING (DEFROST CYCLE)	COMPRESSOR LOCK OUT COOLING	COMPRESSOR LOCK OUT HEATING
COMPRESSOR CONTACTOR CR1	ENERGIZED	ENERGIZED	ENERGIZED	DE-ENERGIZED	DE-ENERGIZED
EMERGENCY HEAT RELAY CR2	DE-ENERGIZED	DE-ENERGIZED	DE-ENERGIZED	DE-ENERGIZED	DE-ENERGIZED
HEAT PUMP CONTROL CONTACT LRI-A	CLOSED	CLOSED	OPEN	CLOSED	CLOSED
HEAT PUMP CONTROL CONTACT LRI-B	CLOSED	CLOSED	CLOSED	OPEN	OPEN
HEAT PUMP CONTROL CONTACT LRI-C	OPEN	OPEN	OPEN	CLOSED	CLOSED
HEAT PUMP CONTROL CONTACT LRI-D	CLOSED	CLOSED	OPEN	CLOSED	CLOSED
HEAT PUMP CONTROL CONTACT LRI-E	OPEN	OPEN	CLOSED	OPEN	OPEN
HIGH PRESSURE SWITCH HP1	CLOSED	CLOSED	CLOSED	OPEN	OPEN
REVERSING VALVE RV1	DE-ENERGIZED	ENERGIZED	DE-ENERGIZED	DE-ENERGIZED	DE-ENERGIZED
FAN MOTOR	ON	ON	OFF	OFF	OFF
COMPRESSOR	ON	ON	ON	OFF	OFF

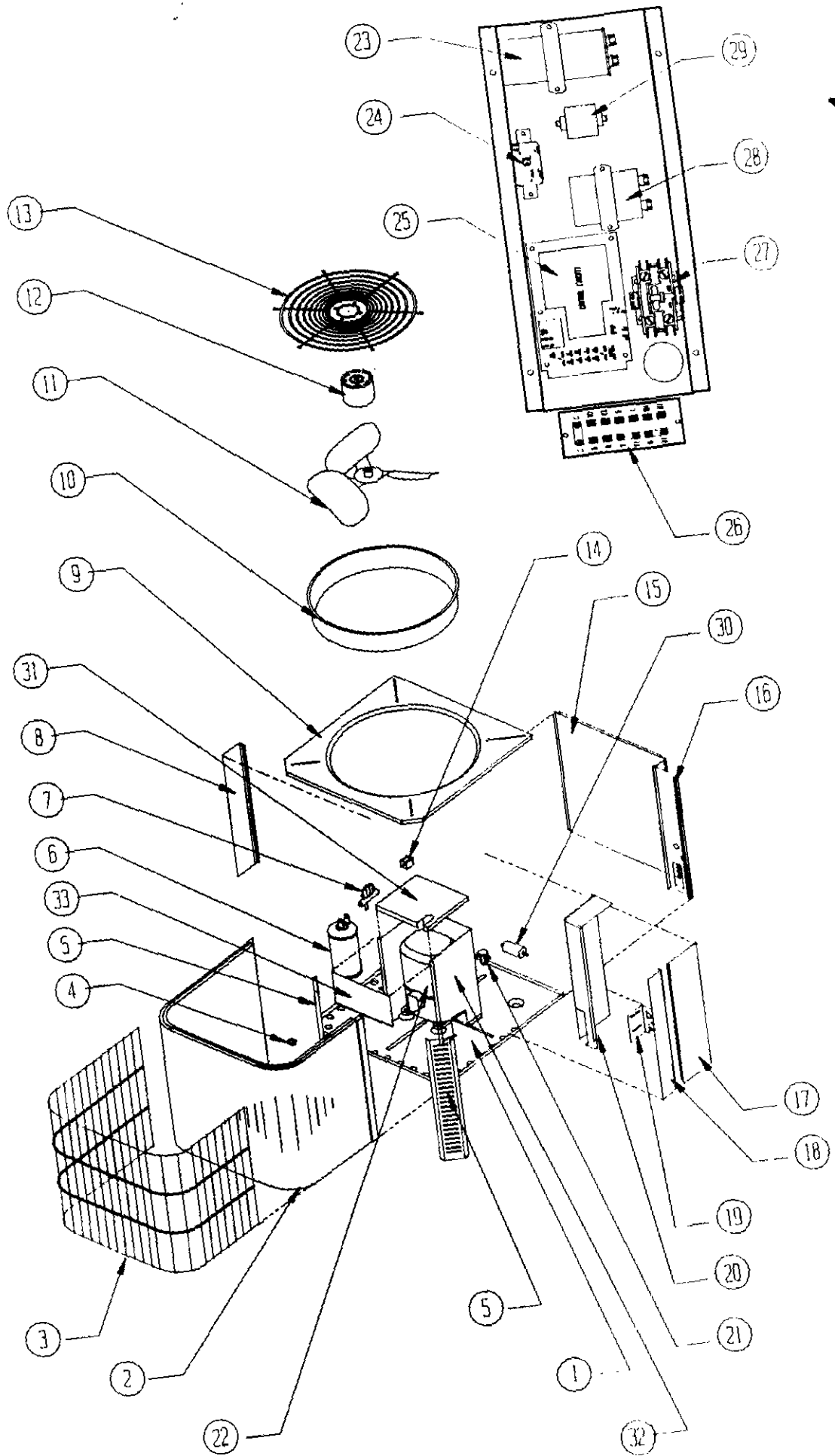

PARTS LIST
SPLIT SYSTEM CONDENSING UNITS

Date: 3/8/89

Item No.	Part No.	Description	2	3	3
			4	0	6
			U	U	U
			H	H	H
			P	P	P
			Q	Q	Q
			A	A	A
1	127-114	Base Assembly	X	X	X
2	5051-055	Condenser Coil	X	X	
2	5051-056	Condenser Coil			X
3	7051-019	Coil Grille	X	X	X
4	8408-019	Ther. Sensor	X	X	X
5	148-055	Front Cover	X	X	X
6	5202-016	Accumulator	X	X	X
7	5650-005	Reversing Valve	X		
7	5650-013	Reversing Valve		X	X
8	148-056	Left Rear Corner	X	X	X
19	106-096	Top	X	X	X
10	167-011	Fan Venturi	X	X	X
11	5151-039	Fan Blade	X	X	X
12	8102-010	Fan Motor 1/6 HP	X	X	X
13	7051-018	Fan Motor Mount Grille	X	X	X
14	5650-008	Reversing Valve Solenoid	X	X	X
15	152-144	Service Door	X	X	X
16	148-054	Control Panel Cover	X	X	X
17	132-064	Control Panel Cover	X	X	X
18	100-146	Right Side	X	X	X
19	140-144	Quick Connect Support	X	X	X
20	116-094	Control Panel Wrapper	X	X	X
21	5651-070	Expansion Valve		X	
21	5651-071	Expansion Valve			X
21	5651-072	Expansion Valve	X		
22	8000-099	Compressor H23B283ABCA		X	
22	8000-055	Compressor CRH3-0275-PFV			X
22	8000-101	Compressor H23B223ABC	X		
23	8552-032	Capacitor 35/370V		X	
23	8552-035	Capacitor 40/370V			X
23	8552-045	Capacitor 30/370	X		
24	8201-008	Emergency Heat Relay	X	X	X
25	8201-055	Heat Pump Control	X	X	X
26	8607-019	Terminal Strip	X	X	X
27	8401-007	Compressor Contactor 25 Amp	X	X	X
28	8552-002	Capacitor 5/370V	X	X	X
29	8551-005	Motor Starting Device	X	X	X
30	5201-009	Heat Pump Filter Drier	X	X	X
31	534-078	Sound Enclosure Top			X
32	534-076	Sound Enclosure Wrapper			X
33	534-081	Sound Enclosure Front			X
	4086-110	Wiring Diagram	X	X	X
	5625-059	Restrictor w/.059" Orifice	X		
	5625-067	Restrictor w/.067" Orifice		X	
	5625-072	Restrictor w/.072" Orifice			X
	8408-008	Outdoor Thermostat			Field Inst.

Outdoor Model
24UHPQA
COOLING

TABLE 9

Indoor Model	Return Air Temperature	Pressure	Air Temperature Entering Outdoor Coil Degree F								
			75	80	85	90	95	100	105	110	115
BC24B Rated CFM 800	75 deg DB	Low Side	66	70	73	75	77	78	79	79	79
	62 deg WB	High Side	170	185	200	216	231	246	262	277	293
	80 deg DB	Low Side	71	75	78	80	82	83	84	85	85
	67 deg WB	High Side	174	190	205	221	237	253	269	285	301
A30AQ-A Rated CFM 800	85 deg DB	Low Side	77	81	84	86	88	89	90	91	91
	72 deg WB	High Side	181	197	213	229	245	261	278	294	311
	75 deg DB	Low Side	63	66	69	71	73	75	76	77	78
	62 deg WB	High Side	168	183	199	215	230	245	261	276	291
A30AQ-A Rated CFM 800	80 deg DB	Low Side	68	71	74	76	78	80	81	82	83
	67 deg WB	High Side	173	189	204	220	236	252	268	283	299
	85 deg DB	Low Side	72	76	79	82	84	86	87	88	89
	72 deg WB	High Side	178	194	211	228	244	260	277	293	309

TABLE 10

HEATING			Air Temperature Entering Outdoor Coil Degree F														
Model	Return Air Temperature	Pressure	0	5	10	15	17	20	25	30	35	40	45	47	50	55	60
BC24B Rated CFM 800	70 Degree D.B.	Low Side	25	27	30	33	34	36	40	44	48	53	58	60	63	69	75
		High Side	135	149	162	174	178	184	194	203	211	218	234	226	229	233	236
A30AQ-A Rated CFM 800	70 Degree D.B.	Low Side	20	23	26	29	31	33	38	42	47	52	58	60	64	70	76
		High Side	209	207	208	211	213	217	225	235	248	263	281	289	301	324	349

Low side pressure + 2 PSIG (suction service port @ quick support plate)
High side pressure + 5 PSIG (location line @ outdoor unit quick connect)

Tables are based upon rated CFM (airflow) across the evaporator coil and should be found under section titled "Refrigerant Charge" elsewhere in manual. If there is any doubt as to correct operating charge being in the system, the charge should be removed, system evacuated, and recharged to serial plate instructions.

Outdoor Model
30URPQA
COOLING

TABLE 11

Air Temperature Entering Outdoor Coil Degree F

Indoor Model	Return Air Temperature	Pressure	°	°	°	°	°	°	°	°	°
			75	80	85	90	95	100	105	110	115
BC36B Rated CFM 1050	75 deg. DB	Low Side	69	70	72	73	75	77	78	79	81
	62 deg. WB	High Side	183	193	206	219	236	254	274	296	319
	80 deg. DB	Low Side	74	75	77	78	80	82	83	85	86
	67 deg. WB	High Side	188	198	211	225	242	261	281	304	328
	85 deg. DB	Low Side	79	81	83	84	86	88	89	91	92
	72 deg. WB	High Side	195	205	218	233	251	270	291	315	339
BC35B Rated CFM 975	75 deg. DB	Low Side	66	67	68	69	70	71	73	74	76
	62 deg. WB	High Side	174	187	200	213	228	243	260	277	294
	80 deg. DB	Low Side	71	72	73	74	75	76	78	79	81
	67 deg. WB	High Side	179	192	205	219	234	250	266	284	302
	85 deg. DB	Low Side	76	77	78	80	81	82	84	85	87
	72 deg. WB	High Side	185	199	212	227	242	260	275	294	312
A36AQ-A Rated CFM 1050	75 deg. DB	Low Side	65	67	69	71	73	75	76	77	78
	62 deg. WB	High Side	170	186	203	219	236	253	270	287	304
	80 deg. DB	Low Side	70	72	74	76	78	80	81	82	83
	67 deg. WB	High Side	175	191	208	225	242	259	277	294	312
	85 deg. DB	Low Side	75	77	80	82	84	86	87	88	89
	72 deg. WB	High Side	181	198	215	233	250	268	287	304	322
A42AS-A Rated CFM 1050	75 deg. DB	Low Side	68	69	71	72	74	76	77	79	80
	62 deg. WB	High Side	176	189	203	217	233	250	268	288	308
	80 deg. DB	Low Side	73	74	76	77	79	81	82	84	85
	67 deg. WB	High Side	181	194	208	223	239	256	275	295	316
	85 deg. DB	Low Side	78	80	82	83	85	87	88	90	91
	72 deg. WB	High Side	187	200	215	231	247	265	285	305	327

TABLE 12

HEATING

Air Temperature Entering Outdoor Coil Degree F

Model	Return Air Temperature	Pressure	°	°	°	°	°	°	°	°	°	°	°	°	°	°	
			0	5	10	15	17	20	25	30	35	40	45	47	50	55	60
BC36B Rated CFM 1050	° 70 DB	Low Side	11	16	21	26	28	31	36	40	45	50	54	56	59	63	68
		High Side	131	143	154	164	168	174	182	191	198	205	211	213	216	221	225
BC35B Rated CFM 975	° 70 DB	Low Side	20	22	25	29	30	32	36	40	44	48	53	55	58	63	68
		High Side	170	171	173	176	178	181	187	194	202	212	222	227	234	248	262
A36AQ-A Rated CFM 1050	° 70 DB	Low Side	11	16	21	26	28	31	36	40	45	50	54	56	59	63	68
		High Side	131	144	155	166	170	176	185	193	201	208	214	216	219	223	227
A42AS-A Rated CFM 1050	° 70 DB	Low Side	20	22	25	28	29	31	35	39	43	48	53	55	58	64	70
		High Side	168	166	165	166	167	168	173	178	185	194	204	208	215	228	243

Low side pressure ± 2 PSIG (suction service port @ quick support plate)

High side pressure ± 5 PSIG (location line @ outdoor unit quick connect)

Tables are based upon rated CFM (airflow) across the evaporator coil and should be found under section titled "Refrigerant Charge" elsewhere in manual. If there is any doubt as to correct operating charge being in the system, the charge should be removed, system evacuated, and recharged to serial plate instructions.

TABLE 13

Air Temperature Entering Outdoor Coil Degree F

Indoor Model	Return Air Temperature	Pressure	Air Temperature Entering Outdoor Coil Degree F								
			75	80	85	90	95	100	105	110	115
BC36B Rated CFM 1200	75 deg. DB	Low Side	62	64	65	66	68	70	71	73	74
	62 deg. WB	High Side	180	194	209	222	236	250	263	278	291
	80 deg. DB	Low Side	67	68	70	71	73	75	76	78	79
	67 deg. WB	High Side	185	199	214	228	242	256	270	285	299
BC35B Rated CFM 1125	85 deg. DB	Low Side	72	73	75	76	78	81	82	84	85
	72 deg. WB	High Side	191	206	221	236	250	265	279	295	309
	75 deg. DB	Low Side	55	58	60	62	65	66	68	70	71
	62 deg. WB	High Side	172	188	205	221	238	253	270	285	300
A36AQ-A Rated CFM 1200	80 deg. DB	Low Side	59	62	64	67	69	71	73	75	76
	67 deg. WB	High Side	176	193	210	227	244	260	277	292	308
	85 deg. DB	Low Side	63	66	68	72	74	76	78	81	82
	72 deg. WB	High Side	182	199	217	235	252	269	286	302	319
A42AS-A Rated CFM 1200	75 deg. DB	Low Side	61	62	64	66	68	70	71	73	74
	62 deg. WB	High Side	176	192	208	222	238	252	268	283	297
	80 deg. DB	Low Side	65	67	69	71	73	75	76	78	79
	67 deg. WB	High Side	180	197	213	228	244	259	275	290	305
A42AS-A Rated CFM 1200	85 deg. DB	Low Side	69	72	74	76	78	81	82	84	85
	72 deg. WB	High Side	186	204	220	236	253	268	285	300	316
	75 deg. DB	Low Side	61	62	64	65	68	70	72	74	76
	62 deg. WB	High Side	178	192	207	221	237	252	269	285	302
A42AS-A Rated CFM 1200	80 deg. DB	Low Side	65	67	69	70	73	75	77	79	81
	67 deg. WB	High Side	183	197	212	227	243	259	276	293	310
	85 deg. DB	Low Side	69	72	74	75	78	81	83	85	87
	72 deg. WB	High Side	189	204	219	235	251	268	286	303	321

TABLE 14

HEATING

Air Temperature Entering Outdoor Coil Degree F

Model	Return Air Temperature	Pressure	Air Temperature Entering Outdoor Coil Degree F														
			0	5	10	15	17	20	25	30	35	40	45	47	50	55	60
BC36B Rated CFM 1200	70 D.B.	Low Side	27	26	26	27	28	29	32	36	40	45	51	54	58	66	75
		High Side	167	170	174	178	180	183	189	196	204	213	222	226	232	243	255
BC35B Rated CFM 1125	70 D.B.	Low Side	21	23	25	28	29	31	34	38	42	46	51	53	56	61	67
		High Side	174	185	196	207	211	218	229	240	251	262	273	278	285	296	308
A36AQ-A Rated CFM 1200	70 D.B.	Low Side	23	24	25	27	28	30	32	36	40	45	50	52	56	62	69
		High Side	162	172	181	190	194	199	208	217	225	233	241	244	249	256	263
A42AS-A Rated CFM 1200	70 D.B.	Low Side	27	26	26	27	28	29	32	35	39	44	50	52	56	66	71
		High Side	196	190	186	185	185	186	190	196	204	215	228	234	244	262	282

Low side pressure \pm 2 PSIG (suction service port @ quick support plate)
High side pressure \pm 5 PSIG (location line @ outdoor unit quick connect)

Tables are based upon rated CFM (airflow) across the evaporator coil and should be found under section titled "Refrigerant Charge" elsewhere in manual. If there is any doubt as to correct operating charge being in the system, the charge should be removed, system evacuated, and recharged to serial plate instructions.

Outdoor Model	Indoor Model	D.B. W.B*	Cooling Capacity	75	80	85	90	95	100	105	110	115
24UHPQA	BC24B	75/	Total Cooling	24600	23900	23110	22200	21200	20100	18860	17540	16100
		62/	Sensible Cooling	18470	18300	18040	17700	17300	16820	16250	15620	14900
		80/	Total Cooling	26340	26140	25740	25160	24400	23450	22320	21000	19500
		67/	Sensible Cooling	18000	18030	17940	17760	17500	17150	16720	16200	15600
		85/	Total Cooling	26630	27170	27400	27350	27000	26350	25400	24160	22620
		72/	Sensible Cooling	16870	16600	16360	16160	16000	15870	15780	15700	15700
24UHPQA	A30AQ-A	75/	Total Cooling	24900	23990	22990	21900	20800	19600	18330	17000	15600
		62/	Sensible Cooling	18130	17900	17600	17240	16800	16280	15700	15000	14300
		80/	Total Cooling	26630	26210	25600	24900	24000	22940	21700	20340	18800
		67/	Sensible Cooling	17670	17640	17520	17520	17000	16600	16130	15560	14900
		85/	Total Cooling	26890	27240	27300	27100	26600	25800	24760	23420	21800
		72/	Sensible Cooling	16160	16200	16190	16120	16000	15830	15600	15330	15000
30UHPQA	BC35B	75/	Total Cooling	29620	27730	25930	24220	22600	21070	19620	18270	17000
		62/	Sensible Cooling	22740	21920	21130	20350	19600	18870	18160	17470	16800
		80/	Total Cooling	31730	30280	28840	27410	26000	24600	23220	21850	20500
		67/	Sensible Cooling	22110	21530	20950	20380	19800	19220	18650	18070	17500
		85/	Total Cooling	32000	31380	30640	29780	28800	27700	26490	25150	23700
		72/	Sensible Cooling	19600	19620	19550	19410	19200	18910	18550	18110	17600
30UHPQA	BC36B	75/	Total Cooling	32300	30100	28190	26550	25200	24130	23340	22830	22600
		62/	Sensible Cooling	25130	24170	23270	22450	21700	21020	20410	19870	19400
		80/	Total Cooling	34290	32850	31490	30210	29000	27860	26800	25810	24900
		67/	Sensible Cooling	24440	23760	23130	22540	22000	21510	21060	20660	20300
		85/	Total Cooling	34760	34150	33510	32820	32100	31340	30530	29690	28800
		72/	Sensible Cooling	21560	21600	21590	21520	21400	21230	21000	20730	20400
30UHPQA	A36AQ-A	75/	Total Cooling	30170	28760	27350	25930	24500	23060	21620	20160	18700
		62/	Sensible Cooling	25530	25030	24440	23760	23000	22150	21220	20200	17100
		80/	Total Cooling	32210	31370	30420	29360	28200	26930	25560	24100	22500
		67/	Sensible Cooling	24700	24590	24330	23930	23400	22720	21920	20980	19900
		85/	Total Cooling	32430	32530	32380	31960	31300	30380	29200	27780	26100
		72/	Sensible Cooling	22400	22490	22480	22340	22100	21740	21270	20700	20000
30UHPQA	A42AS-A	75/	Total Cooling	31540	29810	28100	26430	24800	23200	21630	20100	18600
		62/	Sensible Cooling	24620	24200	23650	22940	22100	21110	19980	18710	17300
		80/	Total Cooling	33630	32480	31260	29970	28600	27160	25650	24060	22400
		67/	Sensible Cooling	24360	23890	23410	22900	22400	21870	21330	20770	20200
		85/	Total Cooling	34010	33760	33290	32610	31700	30580	29240	27680	25900
		72/	Sensible Cooling	21700	21790	21800	21740	21600	21390	21100	20740	20300
36UHPQA	BC35B	75/	Total Cooling	33240	31430	29600	27760	25900	24020	22130	20220	18300
		62/	Sensible Cooling	24520	23950	23310	22590	21800	20940	20000	18990	17900
		80/	Total Cooling	35630	34350	32950	31430	29800	28050	26190	24200	22100
		67/	Sensible Cooling	24020	23580	23120	22620	22100	21550	20960	20350	19700
		85/	Total Cooling	35910	35600	35010	34150	33000	31570	29860	27870	25600
		72/	Sensible Cooling	21570	21530	21440	21300	21100	20850	20550	20200	19800
36UHPQA	BC36B	75/	Total Cooling	36580	34810	33040	31270	29500	27730	25960	24190	22420
		62/	Sensible Cooling	27420	26760	26110	25450	24800	24150	23490	22840	22180
		80/	Total Cooling	39380	38040	36690	35350	34000	32650	31310	29960	28620
		67/	Sensible Cooling	26790	26370	25950	25520	25100	24680	24250	23830	23410
		85/	Total Cooling	40160	39550	38930	38320	37700	37080	36470	35850	35240
		72/	Sensible Cooling	24210	24130	24050	23980	23900	23820	23750	23670	23590
36UHPQA	A36AQ-A	75/	Total Cooling	35420	33770	32100	30410	28700	26980	25230	23480	21700
		62/	Sensible Cooling	26820	26940	26730	26180	25300	24080	22520	20630	18400
		80/	Total Cooling	37900	36850	35690	34400	33000	31480	29840	28080	26200
		67/	Sensible Cooling	25920	26410	26520	26250	25600	24570	23160	21370	19200
		85/	Total Cooling	38250	38270	38010	37450	36600	35460	34030	32310	30300
		72/	Sensible Cooling	23560	24150	24420	24370	24000	23310	22290	20960	19300
36UHPQA	A42AS-A	75/	Total Cooling	35890	34180	32470	30740	29000	27250	25480	23700	21900
		62/	Sensible Cooling	27580	27420	27070	26530	25800	24880	23780	22480	21000
		80/	Total Cooling	38460	37370	36160	34840	33400	31850	30180	28400	26500
		67/	Sensible Cooling	26890	26930	26810	26530	26100	25510	24760	23860	22800
		85/	Total Cooling	38830	38790	38480	37880	37000	35840	34410	32690	30700
		72/	Sensible Cooling	24530	24670	24710	24660	24500	24250	23900	23450	22900

HEATING APPLICATION DATA RATINGS--Air Temperature Entering Outdoor Coil Degree F

Outdoor Model	Indoor Temperature		°	°	°	°	°	°	°	°	°	°	°	°	°	°	°
			0	5	10	15	17	20	25	30	35	40	45	47	50	55	60
24URPQA	BC24B	Btuh	5980	7900	9820	11730	12500	13650	15570	17480	19460	21320	23240	24000	25150	27070	28930
		Watts	1650	1730	1810	1900	1929	1980	2060	2140	2230	2310	2390	2426	2480	2560	2640
		COP	1.33	1.50	1.67	1.83	1.90	2.00	2.17	2.33	2.50	2.67	2.83	2.90	3.00	3.17	3.33
24URPQA	A30AQ-A	Btuh	5530	7580	9630	11680	12500	13730	15780	17830	19880	21930	23980	24800	26030	28080	30130
		Watts	1720	1810	1910	2000	2036	2090	2190	2280	2370	2470	2560	2597	2650	2750	2840
		COP	1.23	1.40	1.56	1.73	1.80	1.90	2.06	2.23	2.40	2.56	2.73	2.80	2.89	3.06	3.23
30URPQA	BC35B	Btuh	6623	8940	11260	13570	14500	15890	18210	20520	22840	25160	27470	28400	29790	32110	34420
		Watts	1880	1980	2090	2200	2238	2300	2410	2510	2620	2720	2830	2872	2940	3040	3150
		COP	1.33	1.50	1.67	1.83	1.90	2.00	2.17	2.33	2.50	2.67	2.83	2.90	3.00	3.17	3.33
30URPQA	BC36B	Btuh	8630	10800	12970	15130	16000	17300	19470	21630	23800	25970	29000	29000	30300	32470	34630
		Watts	2070	2150	2230	2310	2346	2400	2480	2560	2640	2720	2800	2835	2880	2970	3050
		COP	1.43	1.60	1.76	1.93	2.00	2.10	2.26	2.43	2.60	2.76	2.93	3.00	3.10	3.26	3.43
30URPQA	A36AQ-A	Btuh	8810	11040	13280	15510	16400	17740	19970	22210	24440	26670	28910	29800	31140	33370	35610
		Watts	1940	2040	2140	2250	2290	2350	2460	2560	2660	2770	2870	2913	2980	3080	3180
		COP	1.59	1.74	1.89	2.04	2.10	2.19	2.34	2.49	2.64	2.79	2.94	3.00	3.09	3.24	3.39
30URPQA	A42AS-A	Btuh	9500	11620	13740	15850	16700	17970	20090	22000	24320	26440	28550	29400	30670	32790	34900
		Watts	2025	2120	2210	2300	2332	2390	2480	2570	2660	2750	2840	2873	2930	3020	3110
		COP	1.59	1.74	1.89	2.04	2.10	2.19	2.34	2.49	2.64	2.79	2.94	3.00	3.09	3.24	3.39
36URPQA	BC35B	Btuh	10780	13080	15380	17680	18600	19980	22280	24580	26880	29180	31480	32400	33780	36080	38380
		Watts	2350	2460	2571	2680	2727	2790	2900	3020	3130	3240	3350	3394	3460	3570	3680
		COP	1.54	1.68	1.81	1.94	2.00	2.08	2.21	2.34	2.48	2.61	2.74	2.80	2.88	3.01	3.14
36URPQA	BC36B	Btuh	12070	14400	16730	19070	20000	21400	23730	26070	28400	30730	33070	34000	35400	37730	40070
		Watts	2350	2440	2540	2630	2665	2720	2810	2900	3000	3090	3180	3216	3270	3360	3450
		COP	1.69	1.84	1.99	2.14	2.20	2.29	2.44	2.59	2.74	2.89	3.04	3.10	3.19	3.34	3.49
36URPQA	A36AQ-A	Btuh	12290	14560	16830	19090	20000	21360	23630	25890	28160	30430	32690	33600	34960	37230	39490
		Watts	2250	2370	2500	2620	2666	2740	2860	2980	3110	3230	3350	3398	3470	3590	3720
		COP	1.80	1.92	2.03	2.15	2.20	2.27	2.38	2.50	2.62	2.73	2.85	2.90	2.97	3.08	3.20
36URPQA	A42AS-A	Btuh	48240	14640	17040	19440	20400	21840	24240	26640	29040	31440	33840	34800	36246	38640	41040
		Watts	2760	2830	2900	2960	2991	3030	3100	3170	3240	3310	3370	3401	3440	3510	3580
		COP	1.43	1.60	1.76	1.93	2.00	2.10	2.26	2.43	2.60	2.76	2.93	3.00	3.10	3.26	3.43

70 degree F DB Return Air at Rated CFM.