

INSTALLATION INSTRUCTIONS

HIGH EFFICIENCY WATER SOURCE PACKAGED HEAT PUMPS

MODELS

WPV24

WPV30B

WPV36B

WPV53B

WPV62B

Ground Water Temperatures 45° - 75°

**Earth Loop Fluid
Temperatures 30° - 110°F**

MANUAL 2100-155 REV. I
SUPERSEDES REV. H
FILE VOL. I, TAB 8

COPYRIGHT FEBRUARY, 1989
BARD MANUFACTURING COMPANY
BRYAN, OHIO

TABLE OF CONTENTS

I.	General	3
II.	Installation	3
	1. BTUH Capacity Selection	3
	2. Site Selection	3
	3. Ductwork	3
	4. Filter	4
	5. Electrical Wiring	4
	A. Main Power	4
	B. Control Circuit--Low Voltage Wiring	5
	6. Condensate Drain	5
	7. Piping Access To The Unit	5
	8. Water Connections	5
	9. Well Pump Sizing	6
III.	Sequence Of Operation	7
	1. Cooling With Or Without Duct Heaters	7
	2. Single Stage Heat Without Duct Heaters	7
	3. Two Stage Heat With Duct Heaters	7
	4. Emergency Heat	7
IV.	System Start Up Procedure	8
V.	Water Corrosion	9
VI.	Remedies Of Water Problems	10
VII.	Lake and Pond Installations	10
VIII.	Earth Coupled Ground Loop Applications	12
IX.	Add-On Heat Recovery Hot Water Heater	13
	Installation	13
	Start-Up, Check-Out Maintenance	15
	Heat Pump Service	15

FIGURES AND TABLES

Figure 1	1
Figure 2	2
Figure 3	4
Figure 4	6
Figure 5	10
Figure 6	12
Figure 7	13
Figure 8	14
Figure 9	15

Table 1	16
Table 2	16
Table 3	16
Table 4	16
Table 5	16
Table 6	16
Table 7	17
Table 8	17
Table 9	18
Table 10	18
Table 11	19
Table 12	20
Table 13	21

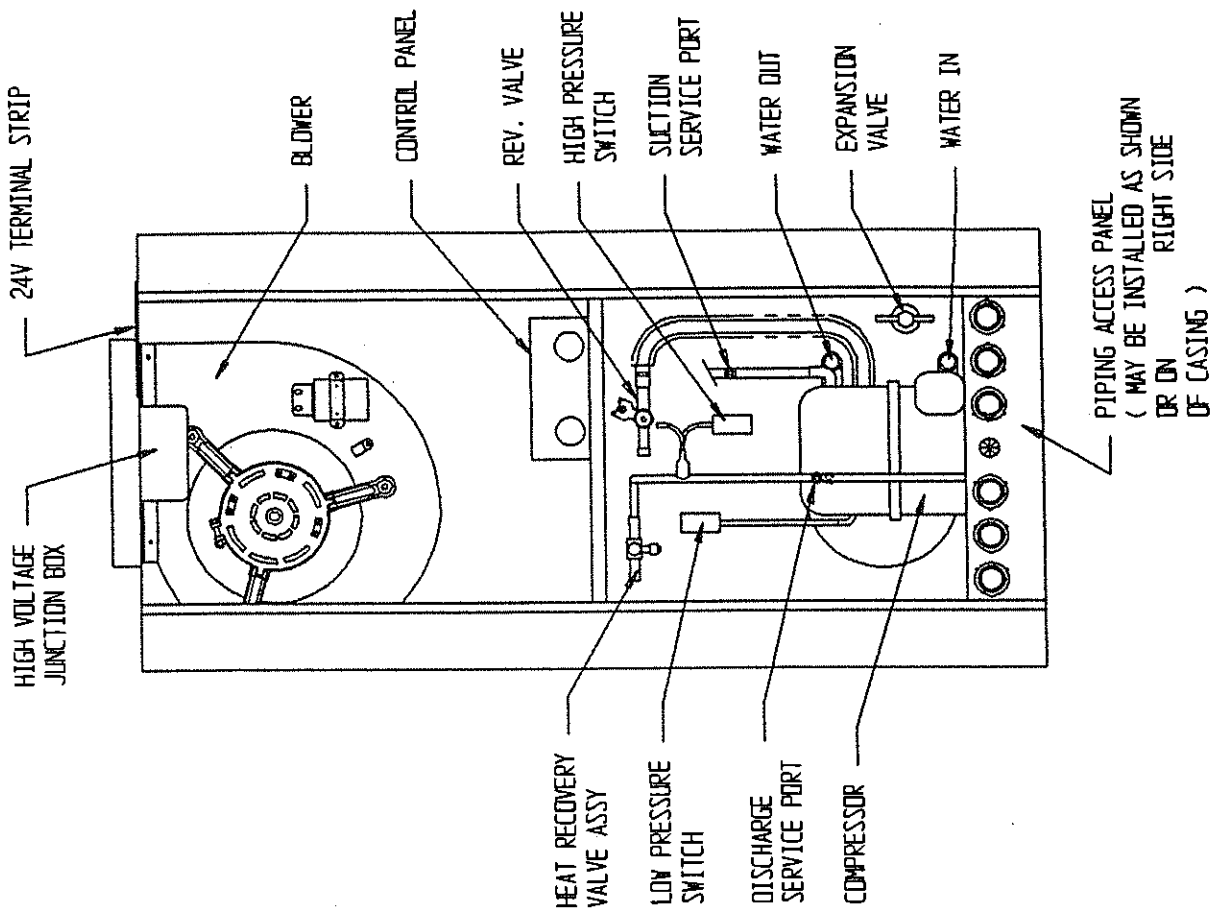

NOTE: IF NO RETURN AIR DUCT IS USED, APPLICABLE INSTALLATION CODES MAY LIMIT THIS CABINET TO INSTALLATION ONLY IN A SINGLE STORY STRUCTURE.

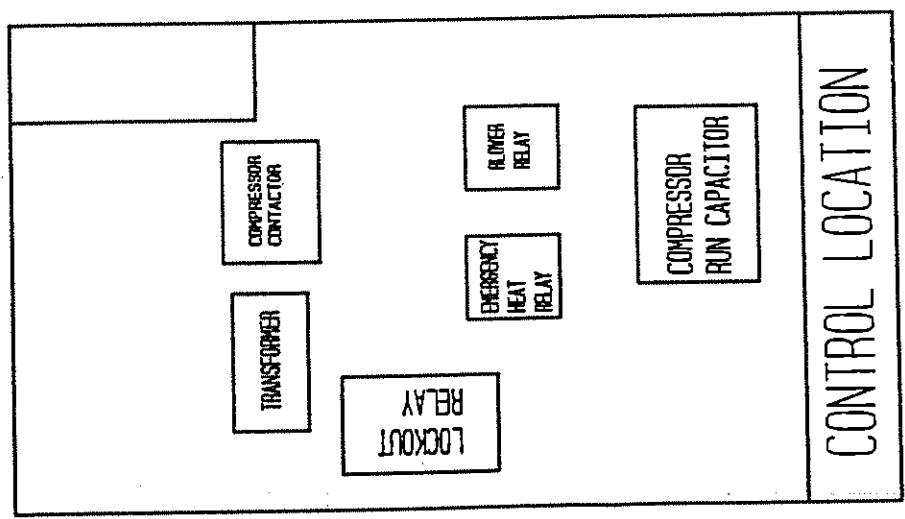

Figure 1

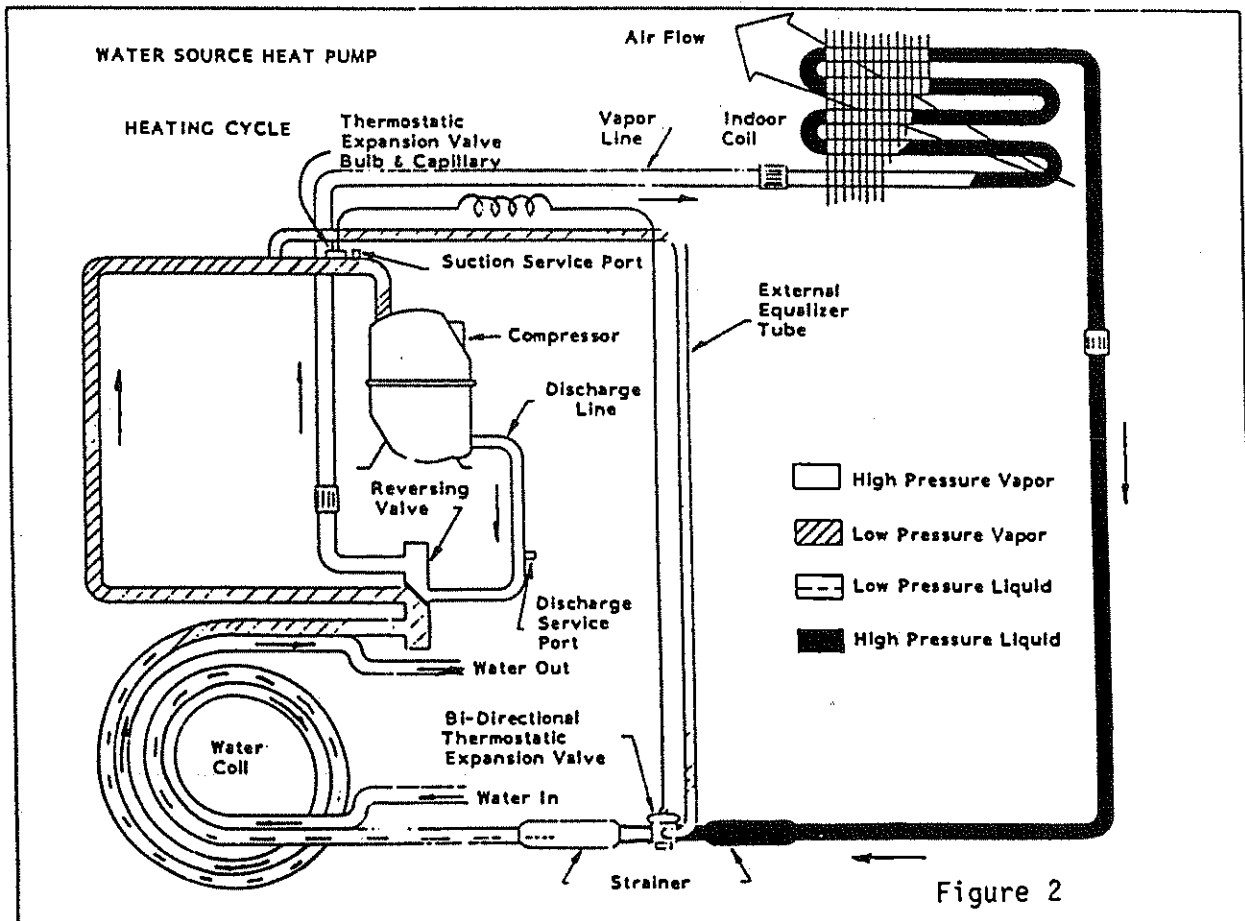
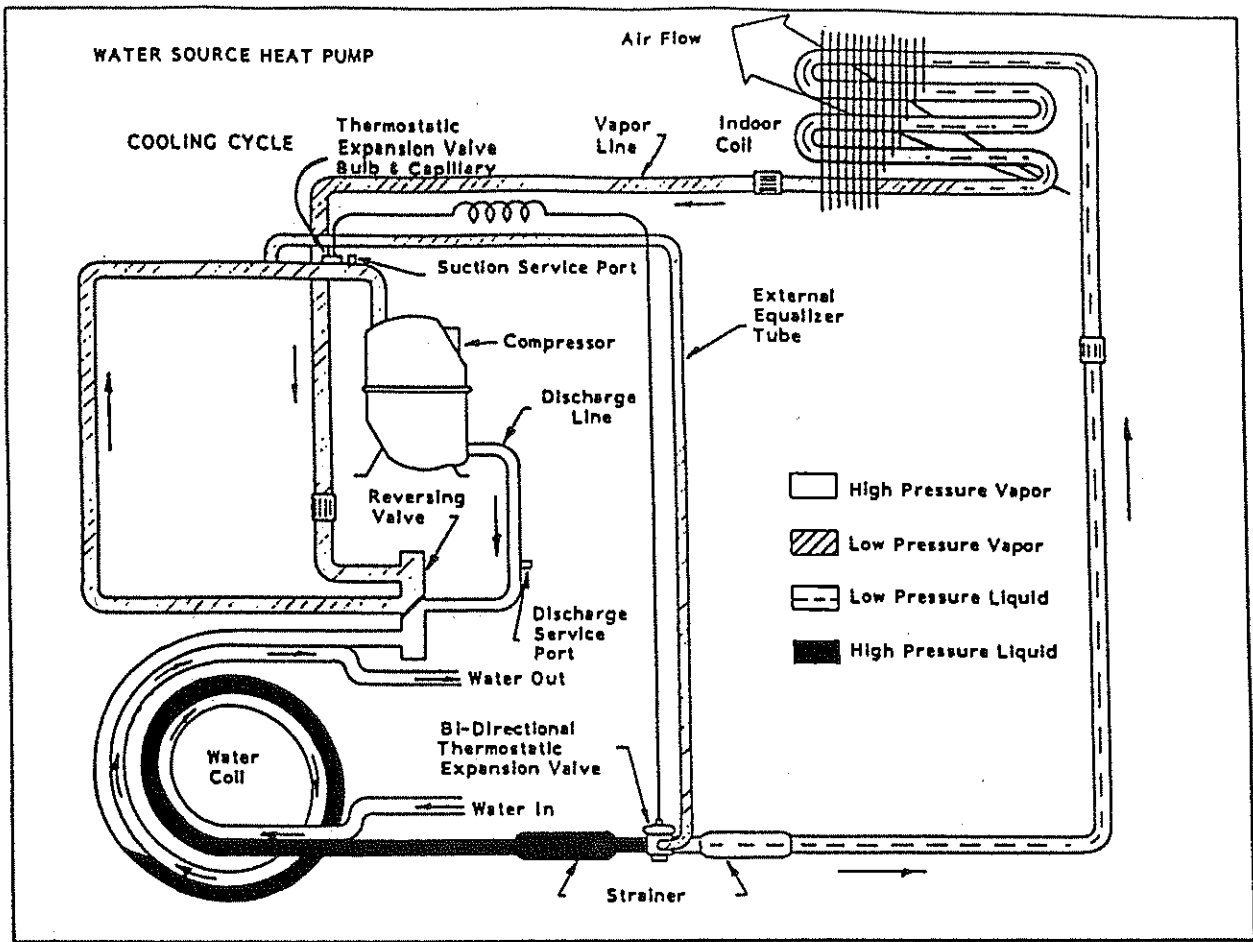

Figure 2

I. GENERAL

Units are shipped completely assembled and internally wired, requiring only duct connections, thermostat wiring, 230-208 volt AC power wiring, and water piping. The equipment covered in this manual is to be installed by trained, experienced service and installation technicians. Any heat pump is more critical of proper refrigerant charge and an adequate duct system than a cooling only air conditioning unit.

These instructions and any instructions packaged with any separate equipment required to make up the entire heat pump system should be carefully read before beginning the installation. Note particularly any tags and/or labels attached to the equipment.

While these instructions are intended as a general recommended guide, they do not in any way supersede any national and/or local codes. Authorities having jurisdiction should be consulted before the installation is made.

Unpacking

Upon receipt of the equipment, the carton should be checked for external signs of shipping damage. If damage is found, the receiving party must contact the last carrier immediately, preferably in writing, requesting inspection by the carrier's agent.

II. INSTALLATION

1. BTUH Capacity Selection

Capacity of the unit for a proposed installation should be based on heat loss calculations made in accordance with methods of the Air Conditioning Contractors of America, formerly National Warm Air Heating and Air Conditioning Association. The air duct system should be sized and installed in accordance with Standards of the National Fire Protection Association For The Installation of Air Conditioning and Ventilating Systems of Other Than Residence Type NEPA No. 90A, and Residence Type Warm Air Heating and Air Conditioning Systems, NEPA No. 90B.

2. Site Selection

The unit may be installed in a basement, closet or utility room provided adequate service access is insured. Ideally, three sides of the unit should have a minimum access clearance of two feet but the unit can be adequately serviced if two or only one side has the minimum two feet clearance. The unit should be located in the conditioned space to prevent freezing of the water lines.

Clearance to combustible materials is 0 inches for the heat pump. If an optional duct heater is installed, follow the instructions packed with the duct heater for specifications regarding clearance to combustible material.

Before setting the unit, consider ease of piping, drain and electrical connections for the unit. Also, for units which will be used with a field installed heat recovery unit, consider the proximity of the unit to the water heater or storage tank. Place the unit on a solid base, preferably concrete, to minimize undesirable noise and vibration. DO NOT elevate the base pan on rubber or cork vibration eliminator pads as this will permit the unit base to act like a drum, transmitting objectionable noise.

3. Ductwork

If the unit is to be installed in a closet or utility room which does not have a floor drain, a secondary drain pan under the entire unit is highly recommended.

DO NOT install the unit in such a way that a direct path exists between any return grille and the unit. Rather, insure that the air entering the return grille will make at least one turn before entering the unit air coil. This will reduce possible objectionable compressor and air noise from entering the occupied space.

Design the ductwork according to methods given by the National Warm Air Heating and Air Conditioning Association. When duct runs through unconditioned spaces, it should be insulated with vapor barrier. It is recommended that flexible connections be used to connect the ductwork to the unit in order to keep the noise transmission to a minimum.

4. Filter

This unit must not be operated without a filter. It comes equipped with a disposable filter which should be checked often and replaced if dirty. Insufficient air flow due to undersized duct systems or dirty filters can result in nuisance tripping of the high or low pressure control. Refer to Table 2 & 3 for correct air flow and static pressure requirements. See Figure 3.

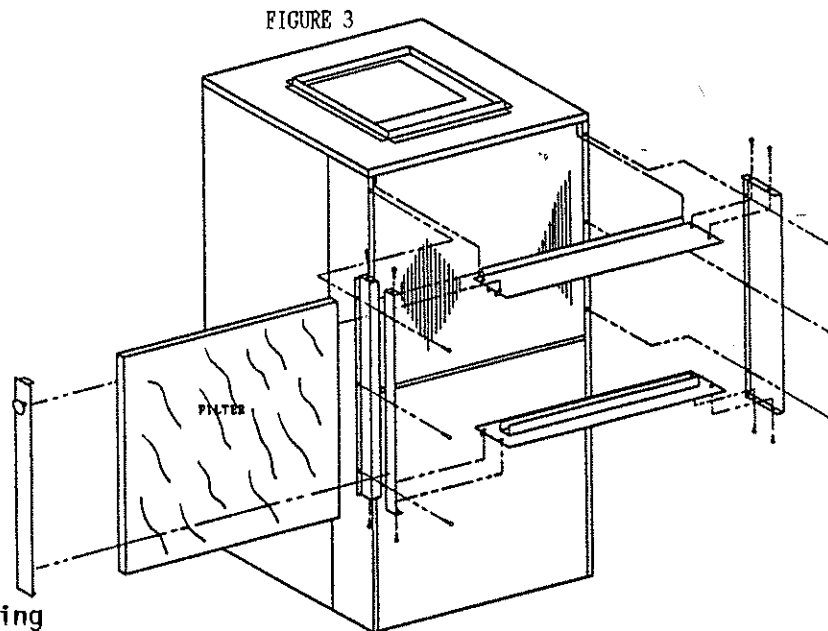

5. Electrical Wiring

All electrical connections are made through the top of the unit. High voltage connections are made with wire nuts to the factory-provided pigtail leads in the junction box. Low voltage connections are made to the terminal strip mounted on the top of the unit. Refer to the wiring diagram for connecting the terminals.

A. Main Power

Refer to the unit serial plate for wire sizing information and correct overcurrent protection size. Each unit is marked with a "Minimum Circuit Ampacity." This means that field wiring connectors must be sized to carry that amount of current. Each unit and/or wiring diagram is also marked "Use Copper Conductors Only," meaning the leads provided are not suitable for aluminum wiring. Refer to the National Electric Code for complete current-carrying capacity data on the various grades of wiring material.

The unit rating plate lists "Maximum Overcurrent Protective Device" that is to be used with the equipment. This device may be a time delay fuse or HACR type circuit breaker. The correct size overcurrent protective device must be used to provide for proper circuit protection and to avoid nuisance trips due to the momentary high starting current of the compressor motor.

B. Control Circuit--Low Voltage Wiring

A 24 volt terminal strip is mounted on top of the unit. Two types of thermostats are available: 1) Single stage heat, single stage cool to operate the heat pump alone--without backup duct style electric heaters. This thermostat is equipped with a signal light to indicate when the unit is "locked out" because of the low or high pressure control. Refer to the wiring diagrams at the end of this manual for correct connection of the terminals. 2) Two stage heat, single stage cool to operate the heat pump or duct heaters on heating or the heat pump on cooling. This thermostat is also equipped with a signal light to indicate when the unit is "locked out" because of operation of the low or high pressure control. In addition, a second signal light tells when the unit has been placed in Emergency Heat. Refer to the wiring diagram at the end of this manual and to the wiring diagram packed with the duct heater for correct connection of the low voltage terminals.

6. Condensate Drain

Determine where the drain line will run. This drain line contains cold water and must be insulated to avoid droplets of water from condensing on the pipe and dropping on finished floors or the ceiling under the unit. A trap **MUST BE** installed in the drain line and the trap filled with water prior to start up. The use of plugged tees in place of elbows to facilitate cleaning is highly recommended.

Drain lines must be installed according to local plumbing codes. It is not recommended that any condensate drain line be connected to a sewer main. The drain line enters the unit through the water access panel, ((3) Figure 4) and connects to the FPT coupling under the condensate drain pan.

7. Piping Access To The Unit

Water piping to and from the unit enters the unit casing through the water access panel. Piping connections are made directly to the heat exchanger coil and are 3/4" or 1" FPT. The access panel can be installed on the front of the unit (as received) or on the right side of the unit. It is highly recommended that the piping from the water coil to the outside of the casing be installed while the unit is completely accessible and before it is finally set in position.

8. Water Connections

It is very important that an adequate supply of clean, non-corrosive water at the proper pressure be provided before the installation is made. Insufficient water, in the heating mode for example, will cause the low pressure control to trip, shutting down the heat pump. In assessing the capacity of the water system, it is advisable that the complete water system be evaluated to prevent possible lack of water or water pressure at various household fixtures whenever the heat pump turns on. All plumbing to and from the unit is to be installed in accordance with local plumbing codes. The use of plastic pipe, where permissible, is recommended to prevent electrolytic corrosion of the water pipe. Because of the relatively cold temperatures encountered with well water, it is strongly recommended that the water lines connecting the unit be insulated to prevent water droplets from condensing on the pipe surface.

Refer to Piping, Figure 4. Slow closing Solenoid Valve (6) with a 24V coil provides on/off control of the water flow to the unit. Refer to the wiring diagram for correct hookup of the valve solenoid coil.

Constant Flow Valve (7) provides correct flow of water to the unit regardless of variations in water pressure. Observe the water flow direction indicated by the arrow on the side of the valve body. Following is a table showing which valve is to be installed with which heat pump.

Heat Pump Model	Flow Rate	Constant Flow Valve Part Number
WPV24	4 GPM	8603-010
WPV30B	4 GPM	8603-010
WPV36B	5 GPM	8603-011
WPV53B	6 GPM	8603-007
WPV62B	8 GPM	8603-008

Strainer (5) installed upstream of constant flow valve (7) to collect foreign material which would clog the flow valve orifice.

The figure shows the use of shut-off valves (9) and (11), on the in and out water lines to permit isolation of the unit from the plumbing system should future service work require this. Globe valves should not be used as shutoff valves because of the excessive pressure drop inherent in the valve design. Instead use gate or ball valves as shut-offs so as to minimize pressure drop.

Drain cock (8) and (10), and tees have been included to permit acid cleaning the refrigerant-to-water coil should such cleaning be required. See WATER CORROSION.

Drain Cock (12) provides access to the system to check water flow through the constant flow valve to insure adequate water flow through the unit. A water meter 1-10 GPM (8603-013) is used to check the water flow rate.

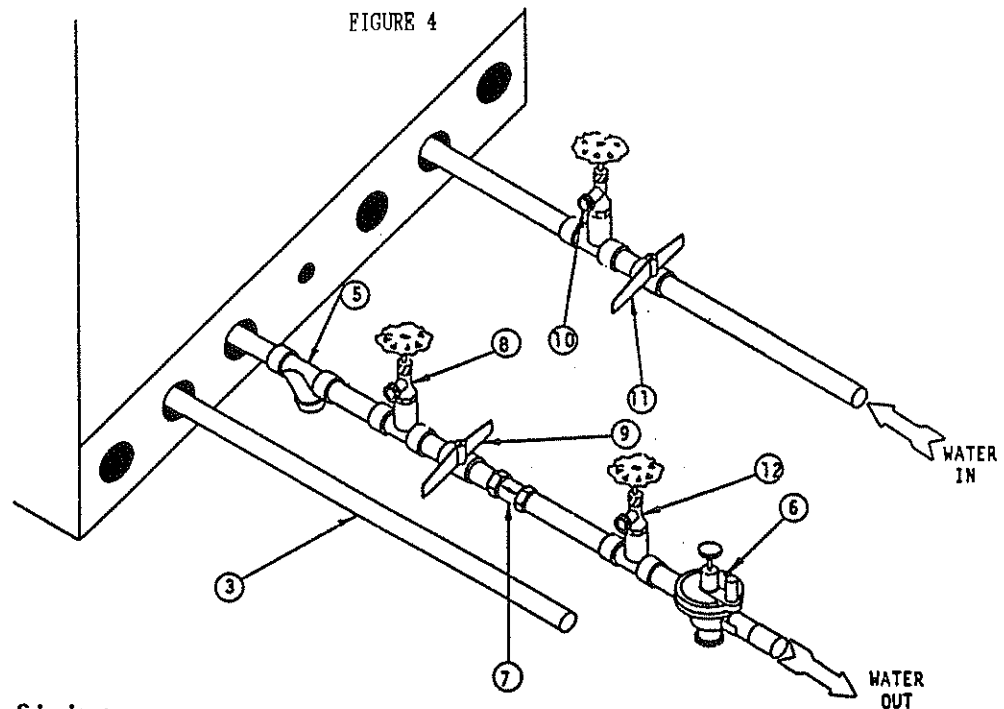

9. Well Pump Sizing

Strictly speaking, sizing the well pump is the responsibility of the well drilling contractor. It is important, however, that the HVAC contractor be familiar with the factors that determine what size pump will be required. Rule of thumb estimates will invariably lead to under or oversized well pumps. Undersizing the pump will result in inadequate water to the whole plumbing system but with especially bad results to the heat pump--NO HEAT/NO COOL calls will result. Oversized pumps will short cycle and could cause premature pump motor or switch failures.

The well pump must be capable of supplying enough water and at an adequate pressure to meet competing demands of water fixtures. The well pump must be sized in such a way that three requirements are met:

1. Adequate flow rate in GPM.
2. Adequate pressure at the fixture.
3. Able to meet the above from the depth of the well-feet of lift.

The pressure requirements put on the pump are directly affected by the diameter of pipe being used as well as by the water flow rate through the pipe. The worksheet included in manual 2100-078 should guarantee that the well pump has enough capacity. It should also ensure that the piping is not undersized which would create too much pressure due to friction loss. High pressure losses due to undersized pipe will reduce efficiency and require larger pumps and could also create water noise problems.

III. SEQUENCE OF OPERATION

1. Cooling With Or Without Duct Heaters

Whenever the system lever is moved to COOL, thermostat system switch completes a circuit R to O, energizing the reversing valve solenoid. On a call for cooling, the cooling bulb completes a circuit from R to G, energizing the blower relay coil. The blower relay contacts complete a 230 volt circuit to the blower motor and the blower operates. R to Y circuit is completed at the same time as the fan circuit and current flows from Y to terminal 4 at the lockout relay. Terminal 4 of the lockout relay provides two paths for current flow.

1. Through the lockout relay coil which offers the resistance of the lockout relay coil.
2. Through the normally closed contacts of the lockout relay to terminal 5 of the lockout relay and then through the high and low pressure switches to the compressor contactor coil.

If the high and low pressure switches remain closed (refrigerant pressure remains normal), the path of least resistance is through these safety controls to the compressor contactor coil. The contacts of the compressor contactor complete a 230 volt circuit to the compressor and the compressor runs. If discharge (suction) pressure reaches the set point of the high (low) pressure control, the normally closed contacts of the high (low) pressure control open and current no longer flows to the compressor contactor coil--the coil drops out. Current now can take the path of least resistance through the lockout relay coil, energizing the lockout relay coil and opening terminals 4 and 5 of the lockout relay. The lockout relay will remain energized as long as a circuit is completed between R and Y at the thermostat. In the meantime, since the compressor is not operating, refrigerant pressure will equalize and the high (low) pressure switch will automatically reset. However, the circuit to the compressor contactor will not be complete until the lockout relay is de-energized by moving the thermostat system switch to OFF, breaking the circuit from R to Y dropping out the lockout relay coil and permitting terminals 4 and 5 to make. When the high (low) pressure switch closes, a circuit is complete to L at the thermostat, energizing the signal light to indicate a malfunction. When the system switch is moved from OFF to COOL, the cycle is repeated.

2. Single Stage Heat Without Duct Heaters

Compressor circuit R to Y including lockout relay and pressure controls is the same as cooling. Blower circuit R to G is the same as cooling. With system switch set to HEAT, no circuit is completed between R and O and reversing valve solenoid is not energized.

3. Two Stage Heat With Duct Heaters

First stage heat is the same as single heating without duct heater. When the second stage thermostat bulb makes, a circuit is completed from C to W2, energizing the duct heater heat contactor, through the heating element and manual reset limit. C to W2 also simultaneously energizes the 24 volt coil on the interlock relay, closing the contacts, which in turn energize the low voltage coil on the blower relay to close the high voltage contacts and power the blower motor. The elements and blower remain energized as long as C to W2 are made.

The following is a verbal description of the proper procedure for connecting the low voltage hookups for the duct heater.

1. Black wire from duct heater to C on the 24 volt terminal block.
2. Green wire from duct heater to green wire from thermostat. These wires must be wire nutted and isolated from the terminal block. Failure to do so will result in improper heater operation.
3. Connect green with tracer from heater to the G terminal on the 24 volt terminal block.
4. Connect the white wire from the heater to W2 on 24 volt terminal block.
 - A. For the 15 and 20kw duct heaters, connect the white and white with black tracer wires to W2.

4. Emergency Heat

When the system switch is moved to EMER, the compressor circuit R to Y is disconnected. Control of the electric heaters is from C to W2 and W3 through the thermostat second stage heating bulb. Blower operation is controlled by the second stage heating bulb. Operation is the same as above, "Two Stage Heat With Duct Heaters."

IV. SYSTEM START UP PROCEDURE

1. Be sure main power to the unit is OFF at disconnect.
2. Set thermostat system switch to OFF, fan switch to AUTO.
3. Move main power disconnect to ON. Power should be on to unit for a minimum of four hours or sixty minutes per pound of refrigerant. This allows the crankcase heater to drive any refrigerant liquid out of the compressor sump. This procedure should be followed whenever the power has been off for twelve hours or longer. Except as required for safety while servicing--DO NOT OPEN THE UNIT DISCONNECT SWITCH.
4. Check system air flow for obstructions.
 - A. Move thermostat fan switch to ON. Blower runs.
 - B. Be sure all registers and grilles are open.
 - C. Move thermostat fan switch to AUTO. Blower should stop.
5. Fully open the manual inlet and outlet valves.
6. Check water flow.
 - A. Connect a water flow meter to the drain cock (12, Figure 4) between the constant flow valve and the solenoid valve. Run a hose from the flow meter to a drain or sink. Open the drain cock.
 - B. Check the water flow rate through constant flow valve to be sure it is the same as the unit is rated for. (Example 4 GPM for a WPV30)
 - C. When water flow is okay, close drain cock and remove the water flow meter. The unit is now ready to start.
7. Start the unit in cooling mode. By moving the thermostat switch to cool, fan should be set for AUTO.
 - A. Check to see the solenoid valve opened.
8. Check the system refrigerant pressures against the cooling refrigerant pressure Table 11, Page 19 in the Installation Manual for rated water flow and entering water temperatures. If the refrigerant pressures do not match, check for air flow problem then refrigeration system problem.
9. Switch the unit to the heating mode. By moving the thermostat switch to heat, fan should be set for AUTO.
 - A. Check to see the solenoid valve opened again.
10. Check the refrigerant system pressures against the heating refrigerant pressure Table 12, Page 20 in

Installation Manual. Once again, if they do not match, check for air flow problems and then refrigeration system problems.

NOTE: If a charge problem is determined (high or low):

- A. Check for possible refrigerant leaks.
- B. Discharge all remaining refrigerant from unit.
- C. Evacuate unit down to 29 inches of vacuum.
- D. Recharge the unit with refrigerant by weight. This is the only way to insure a proper charge.

V. WATER CORROSION

Two concerns will immediately come to light when considering a water source heat pump, whether for ground water or for a closed loop application: Will there be enough water? And, how will the water quality affect the system?

Water quantity is an important consideration and one which is easily determined. The well driller must perform a pump down test on the well according to methods described by the National Well Water Association. This test, if performed correctly, will provide information on the rate of flow and on the capacity of the well. It is important to consider the overall capacity of the well when thinking about a water source heat pump because the heat pump may be required to run for extended periods of time.

The second concern, about water quality, is equally important. Generally speaking, if the water is not offensive for drinking purposes, it should pose no problem for the heat pump. The well driller or local water softening company can perform tests which will determine the chemical properties of the well water.

Water quality problems will show up in the heat pump in one or more of the following ways:

1. Decrease in water flow through the unit.
2. Decreased heat transfer of the water coil (entering to leaving water temperature difference is less).

There are four main water quality problems associated with ground water. These are:

1. Biological Growth. This is the growth of microscopic organisms in the water and will show up as a slimy deposit throughout the water system. Shock treatment of the well is usually required and this is best left up to the well driller. The treatment consists of injecting chlorine into the well casing and flushing the system until all growth is removed.
2. Suspended Particles In The Water. Filtering will usually remove most suspended particles (fine sand, small gravel) from the water. The problem with suspended particles in the water is that it will erode metal parts, pumps, heat transfer coils, etc. So long as the filter is cleaned and periodically maintained, suspended particles should pose no serious problem. Consult with your well driller.
3. Corrosion Of Metal. Corrosion of metal parts results from either highly corrosive water (acid water, generally not the case with ground water) or galvanic reaction between dissimilar metals in the presence of water. By using plastic plumbing or dielectric unions galvanic reaction is eliminated. The use of corrosion resistant materials (such as the Cupro Nickel coil) through the water system will reduce corrosion problems significantly.
4. Scale Formation. Of all the water problems, the formation of scale by ground water is by far the most common. Usually this scale is due to the formation of calcium carbonate but magnesium carbonate or calcium sulfate may also be present. Carbon dioxide gas (CO₂), the carbonate of calcium and magnesium carbonate, is very soluble in water. It will remain dissolved in the water until some outside factor upsets the balance. This outside influence may be a large change in water temperature or pressure. When this happens, enough carbon dioxide gas combines with dissolved calcium or magnesium in the water and falls out of solution until a new balance is reached. The change in temperature that this heat pump produces is

usually not high enough to cause the dissolved gas to fall out of solution. Likewise if pressure drops are kept to a reasonable level, no precipitation of carbon dioxide should occur.

VI. REMEDIES OF WATER PROBLEMS

Water Treatment. Water treatment can usually be economically justified for closed loop systems. However, because of the large amounts of water involved with a ground water heat pump, water treatment is generally too expensive.

Acid Cleaning The Water Coil Or Heat Recovery Unit. If scaling of the coil is strongly suspected, the coil can be cleaned up with a solution of Phosphoric Acid (food grade acid). Follow the manufacturer's directions for mixing, use, etc. Refer to the "Cleaning Water Coil", Figure 5. The acid solution can be introduced into the heat pump coil through the hose bib (Part 8 of Figure 5). Be sure the isolation valves (Parts 9 and 11 of Figure 5) are closed to prevent contamination of the rest of the system by the coil. The acid should be pumped from a bucket into the hose bib (Part 8, Figure 5) and returned to the bucket through the other hose bib (Part 10, Figure 5). Follow the manufacturer's directions for the product used as to how long the solution is to be circulated, but it is usually circulated for a period of several hours.

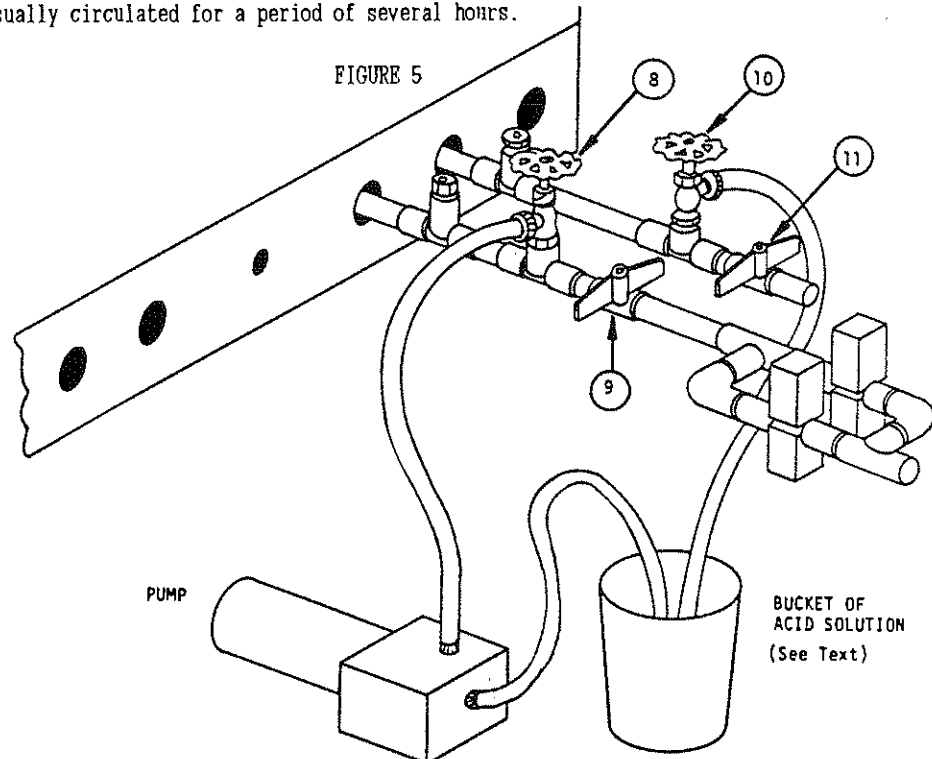

VII. LAKE AND POND INSTALLATIONS

Lakes and ponds can provide a low cost source of water for heating and cooling with a ground water heat pump. Direct usage of the water without some filtration is not recommended as algae and turbid water can foul the water to freon heat exchanger. Instead, there have been very good results using a dry well dug next to the water line or edge. Normal procedure in installing a dry well is to backhoe a 15 to 20 foot hole adjacent to the body of water (set backhoe as close to the water's edge as possible). Once excavated, a perforated plastic casing should be installed with gravel backfill placed around the casing. The gravel bed should provide adequate filtration of the water to allow good performance of the ground water heat pump.

The following is a list of recommendations to follow when installing this type of system:

- A. A lake or pond should be at least 1 acre (40,000 square feet) in surface area for each 50,000 BTUs of ground water heat pump capacity or have 2 times the cubic feet size of the dwelling that you are trying to heat (includes basement if heated).

- B. The average water depth should be at least 5 feet and there should be an area where the water depth is at least 12 to 15 feet deep.
- C. If possible, use a submersible pump suspended in the dry well casing. Jet pumps and other types of suction pumps normally consume more electrical energy than similarly sized submersible pumps. Pipe the unit the same as a water well system.
- D. Size the pump to provide necessary GPM for the ground water heat pump. A 12 GPM or greater water flow rate is required on all modes when used on this type system.
- E. A pressure tank should be installed in the dwelling to be heated adjacent to the ground water heat pump. A pressure switch should be installed at the tank for pump control.
- F. All plumbing should be carefully sized to compensate for friction losses, etc., particularly if the pond or lake is over 200 feet from the dwelling to be heated or cooled.
- G. Keep all water lines below low water level and below the frost line.
- H. Most installers use 4-inch field tile (rigid plastic or corrugated) for water return to the lake or pond.
- I. The drain line discharge should be located at least 100 feet from the dry well location.
- J. The drain line should be installed with a slope of 2 inches per 10 feet of run to provide complete drainage of the line when the ground water heat pump is not operating. This gradient should also help prevent freezing of the discharge where the pipe terminates above the frost line.
- K. Locate the discharge high enough above high water level so the water will not back up and freeze inside the drain pipe.
- L. Where the local conditions prevent the use of a gravity drainage system to a lake or pond, you can instead run standard plastic piping out into the pond below the frost and low water level.

WARNING

THIN ICE MAY RESULT IN THE
VICINITY OF THE DISCHARGE LINE.

For complete information on water well systems and lake and pond applications, refer to Manual 2100-078B (or later edition), available from your distributor.

VIII. EARTH COUPLED GROUND LOOP APPLICATIONS

This unit is also designed to work on earth coupled ground loop systems, however these systems operate at entering water (without antifreeze) temperature well below the temperature normally experienced in water well system. Therefore, when this unit is connected to an earth coupled ground loop, an optional thermostat kit, 8620-002, is required. The kit consists of a SPST thermostat to sense refrigerant temperature and shut off compressor should extremely low antifreeze temperatures or loss of flow occur. See Installation Instructions for thermostat kit packed with the thermostat.

When used on these systems, Item 5 strainer, Item 6 solenoid valve, and Item 7 constant flow valve (refer to Figure 4) are not needed. An external circulating pump must be used.

For information on earth coupled loop design, piping connections to heat pump and installation refer to Manual 2100-099G, "Earth Coupled Loop System Design Manual," available from your distributor.

FIGURE 6

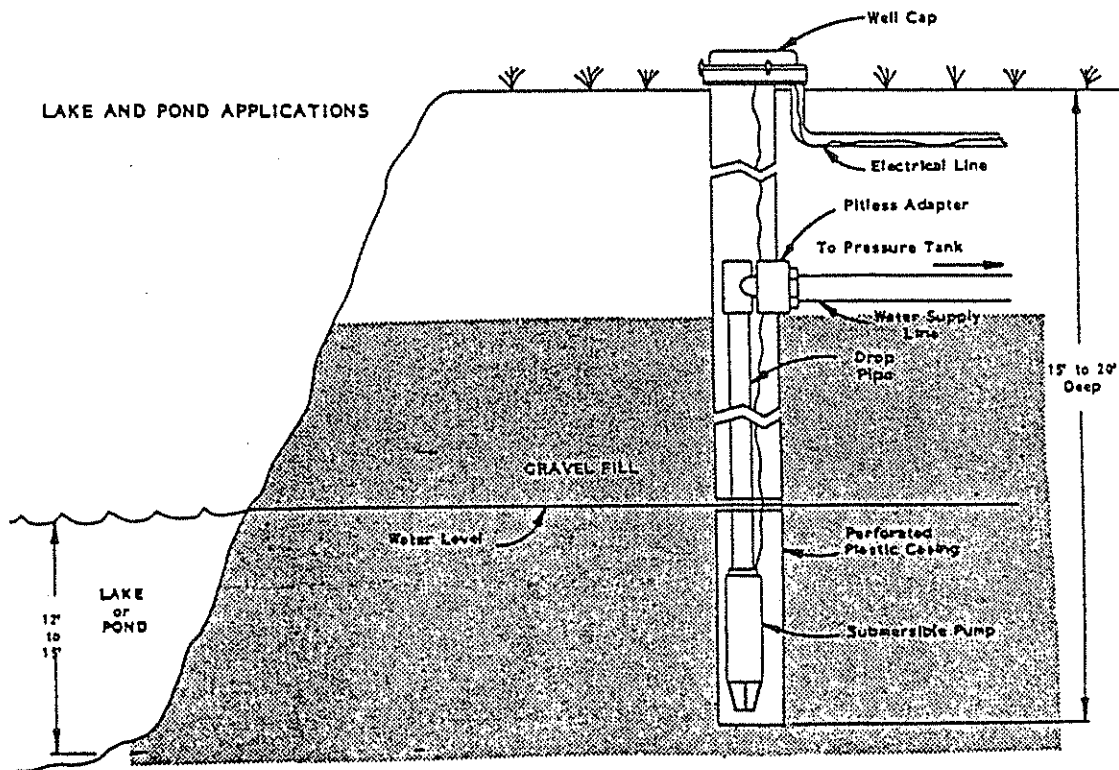

IX. ADD-ON HEAT RECOVERY HOT WATER HEATER

NOTE: This section applies only if a water heating recovery device is added.

GENERAL

This high efficiency water source heat pump series was designed for easy field installation of a heat recovery device for hot water heating commonly known as a desuperheater water heater. The amount of annual hot water supplied and thus additional energy cost savings will depend on the amount of hot water your family uses and the number of hours your heat pump operates. We recommend that a U.L. recognized heat recovery device be used. This device must be suitable for potable water.

Installation

1. Follow all local, state and national codes applicable to the installation of heat recovery devices.
2. Follow the installation procedures you receive with the heat recovery device.
3. Connect the refrigerant lines between the heat recovery device and the heat recovery valves in the heat pump using the inlet and exit panel on the lower left side of the unit as shown in Figure 7. Keep dirt and moisture out of the inter-connecting tubing using good refrigeration service procedures. (See Figure 7). Use refrigeration grade (type L) copper tubing. The tube diameter should be the same as the valve for lengths up to 15 feet each way. For lengths between 15 and 25 feet, increase the diameter 1/8". Avoid placing the heat recovery device over 25 feet from the heat pump.

This tubing should be insulated with Armaflex insulation. Tubing should be protected from abrasion and damage.

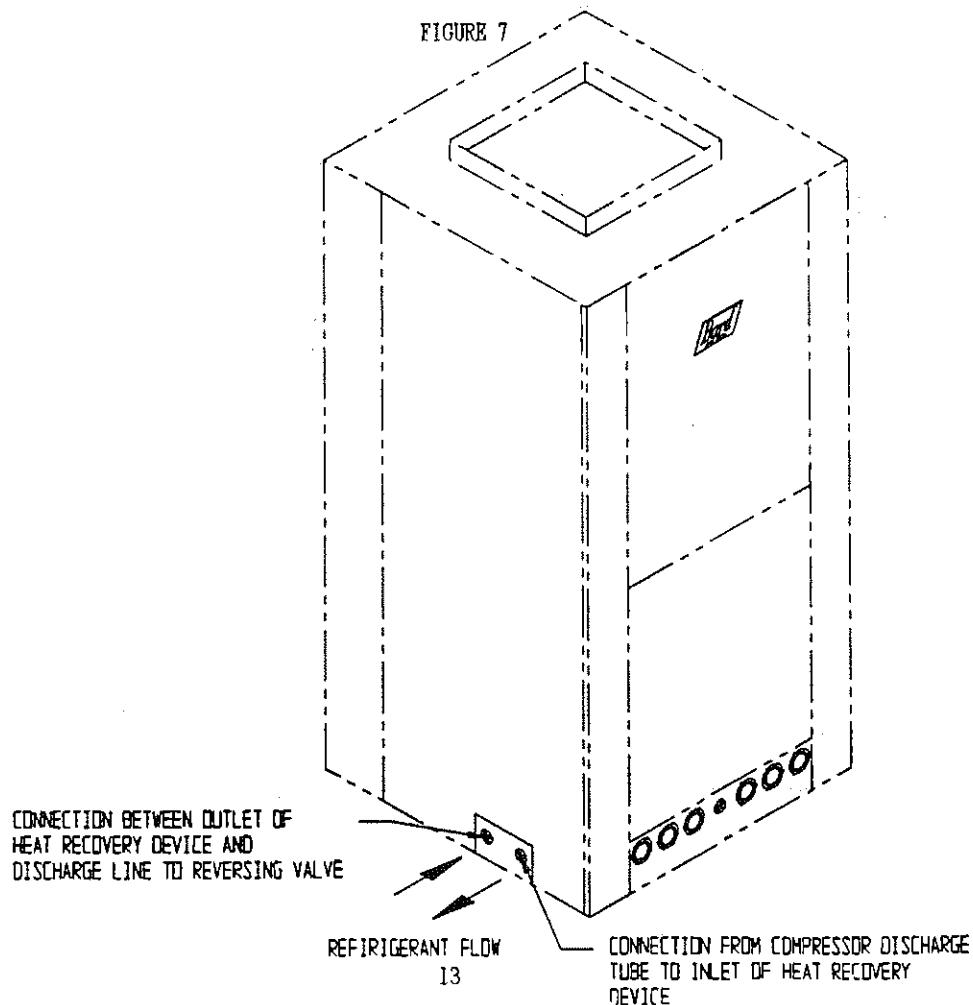

4. Evacuate the heat recovery device inter-connecting tubing and heat exchanger through the process service ports A or B shown in Figure 8 and pressurize with Refrigerant 22 and perform a leak check. Release the charge used for pressurization, leak check and re-evacuate. Add 1 ounce of refrigerant for each 10 feet of additional interconnecting tubing to the total system charge. Replace the caps and tighten.

FIGURE 8

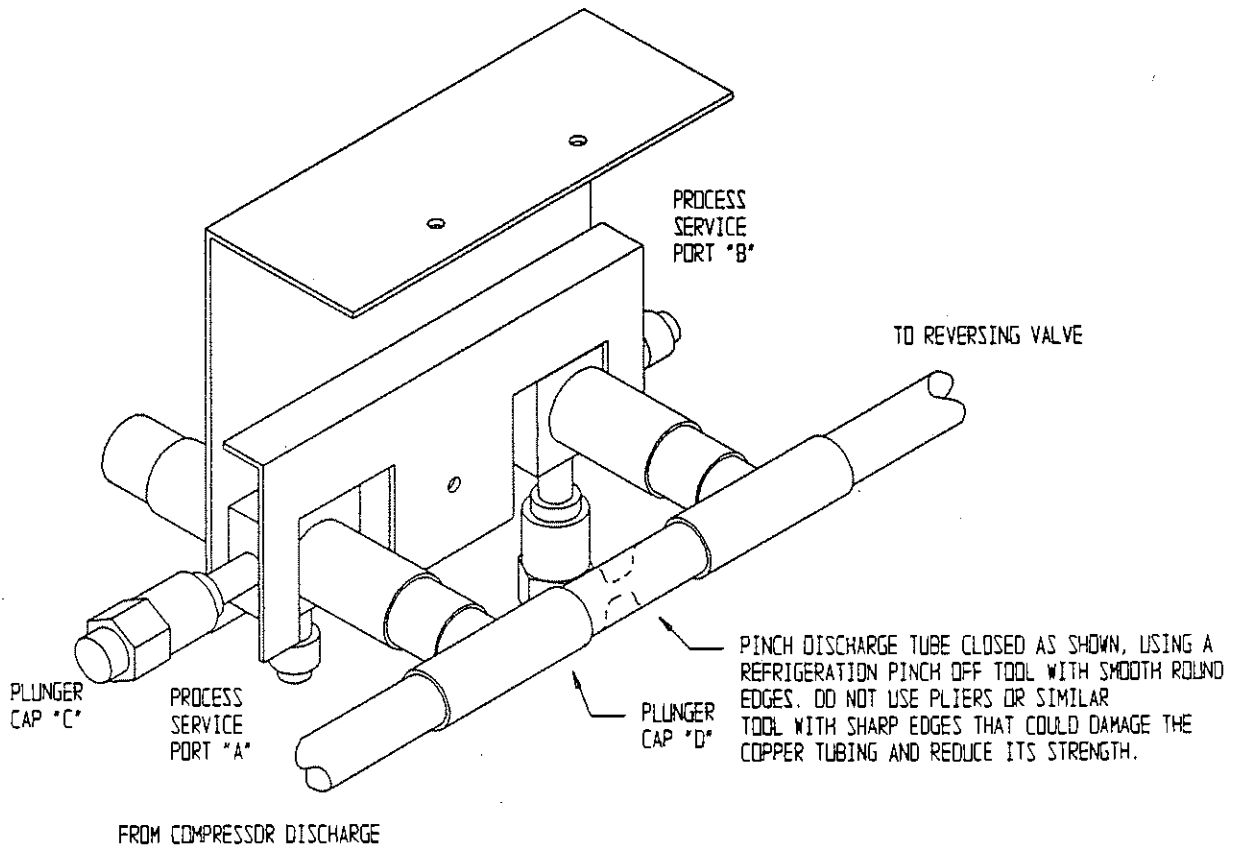

5. Tighten the plunger caps "C" and "D" shown in Figure 8. This forces down a plunger which shears a frangible plug and moves it out of the refrigerant flow path (see Figure 9). This now permits the discharge refrigerant from the compressor to flow through valve at plunger "C" (Figure 8) to the heat recovery coil heat exchanger and back through the valve at plunger "D" and then to the condenser inlet.

FIGURE 9

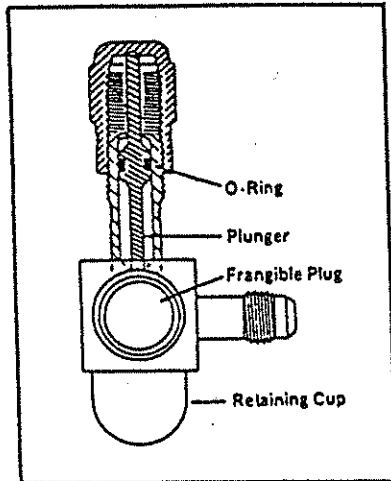

When the plunger cap is tightened, the plunger shears the frangible plug forcing it into the retaining cup. This opens the valve for

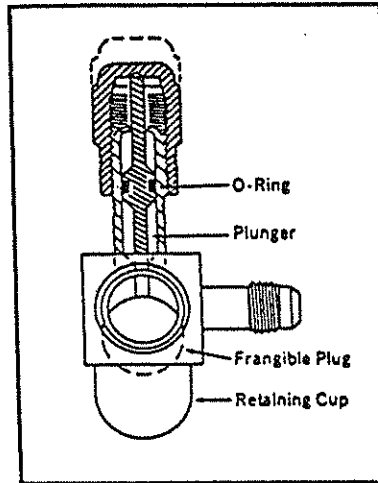

The O-Ring seal on the plunger prevents leakage while the valve is being opened.

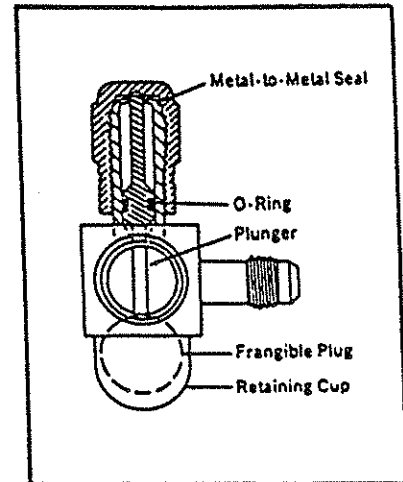

Tightening the plunger cap 1/4 turn after it bottoms results in a metal-to-metal seal.

6. Wire the heat recovery device per the diagram supplied with the heat recovery unit. Turn power to the air conditioner off prior to wiring the heat recovery unit. DO NOT in any way alter any factory or safety circuits on the air conditioner.

Start-Up, Check-Out Maintenance

Follow the procedures supplied with the heat recovery unit.

Heat Pump Service

While performing any heat pump service analysis, turn water pump switch to off as it could affect the refrigerant pressures and be misleading.

ACCESSORY ITEMS--DUCT HEATER (See drawing below)

Part No.	PH	Volts	KW	Minimum Ampacity	Wire Size		Max. Fuse	Dimensions					
					CU	AL		A	B	C	D	E	F
8604-080	1	240	5	27	#10	#8	30	8	10	4	7	7	12
8604-081	1	240	9.8	52	#6	#4	55	8	10	4	7	7	16
8604-082	2	240	14.7	78	#4	#1	80	15	18	4	1	9	18
8604-083	2	240	19.2	100	#2	#0	100	15	18	4	11	9	18

(1) Use wire suitable for a least 75 degree C.
(2) Fused units (over 48 amperes).

**INDOOR BLOWER PERFORMANCE
CFM--DRY COIL WITH FILTER (1)**

Model	WPV24			WPV30B		WPV53B, WPV62B With			WPV53B, WPV62B Without		
	E.S.P. In	Motor Speed			WPV36B		Optional CW45 Installed			Optional CW45 Installed	
E.S.P. In	W.C.	High	Medium	Low	High	Low	High	Medium	Low	High	Medium
0		1033	946	774	1300	1190	1920	1780	1600	1920	1750
.10		983	904	757	1275	1150	1880	1750	1580	1880	1710
.20		942	870	742	1210	1110	1830	1720	1550	1830	1670
.30		903	836	720	1150	1060	1810	1680	1540	1750	1630
.40		857	794	688	1080	1000	1750	1630	1500	1700	1570
.50		799	742	648	1010	930	1650	1570	1440	1610	1520
.60		740	681	603	920	875	1580	1500	1400	1550	1450

(1) For wet coil CFM multiply by .96

TABLE 3

Model	Rated CFM	Recommended Air Flow Range--CFM
WPV24	800	720 - 880
WPV30B	1000	900 - 1090
WPV36B	1200	1070 - 1345
WPV53B	1550	1400 - 1700
WPV62B	1700	1530 - 1830

TABLE 5

WATER COIL PRESSURE DROP

Model	WPV24		WPV30B	WPV36B	WPV53B	WPV62B
	GPM	PSIG	PSIG	PSIG	PSIG	PSIG
3	2.3	5.31	--	--	--	--
4	3.0	6.93	2.0	1.9	--	--
5	3.5	8.08	3.0	2.0	--	--
6	4.1	9.50	4.2	2.4	2.5	2.5
7	4.7	10.85	5.7	3.0	3.2	3.5
8	5.3	12.24	7.5	3.9	4.0	4.5
9	5.9	13.63	9.5	5.5	5.2	5.6
10	6.5	15.01	12.0	7.6	6.5	6.7
11	7.1	16.39	14.8	10.4	7.7	8.0
12	7.7	17.80	17.6	15.3	9.0	9.3
13	--	--	20.3	20.6	10.5	10.7
14	--	--	--	--	12.0	12.3
15	--	--	--	--	13.9	15.5
16	--	--	--	--	15.8	18.3

TABLE 6

FLOW RATES REQUIRED TO MAINTAIN RATED CAPACITY

	WPV24	WPV30B	WPV36B	WPV53B	WPV62B
Flow rate required GPM water	4	5	6	8	
Flow rate required GPM 15% propylene glycol	5.2	6.5	7.8	10.4	
Flow rate required GPM 30% propylene glycol	6.4	8.0	9.6	12.8	

TABLE 4

CONSTANT FLOW VALVES

Part No.	Min. Available Pressure PSIG	Flow Rate GPM
8603-007	15 (1)	6
8603-008	15 (1)	8
8603-010	15 (1)	4
8603-011	15 (1)	5

(1) The pressure drop through the constant flow valve will vary depending on the available pressure ahead of the valve. Unless a minimum of 15 psig is available immediately ahead of the valve no water will flow

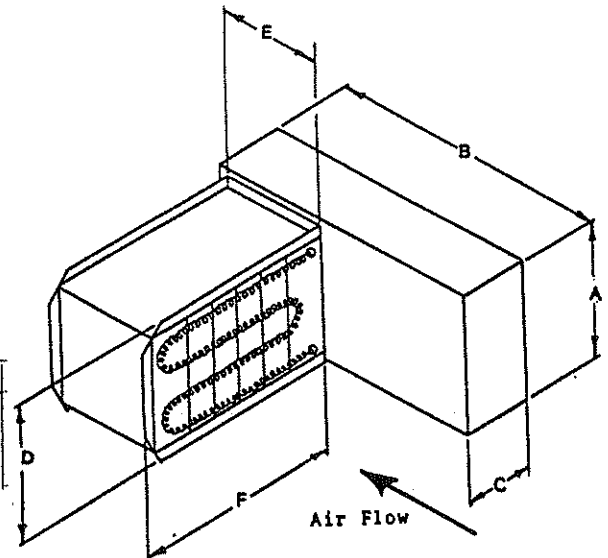

LEGEND

EWT = Entering water temperature °F. (or fluid temperature if applicable)
 GPM = Water flow rate--gallons per minute
 HPD = Water pressure drop--pounds/square inch
 EAT = Entering air temperature °F (dry bulb/wet bulb)
 TC = Total cooling capacity Btu/Hr
 SC = Sensible cooling capacity Btu/Hr

THR = Total heat of rejection Btu/Hr
 EER = Energy efficiency ratio--total cooling - total unit watts
 TH = Total heating capacity Btu/Hr
 TEA = Total heat of absorption Btu/Hr
 COP = Coefficient of performance--total heating - (total unit watts x 3.413)
 ESP = External static pressure (inches of water)

TABLE 7 CAPACITY AND EFFICIENCY APPLICATION RATINGS

HPV24 @ 800 CFM		COOLING						HEATING		
EWT	GPM	EAT	TC	SC	THR	EER(1)	EAT	TH	TEA	COP(1)
30(2)	4.0	75/62 80/67 85/72	21500 23000 25300	17500 18000 18800	26300 28000 30700	20.40 21.20 21.90	70	15000	10400	3.20
40(2)	4.0	75/62 80/67 85/72	21300 22800 25000	17000 17500 18300	26100 27800 30400	18.80 19.50 20.10	70	17200	12800	3.50
50	4.0	75/62 80/67 85/72	21000 22400 24600	16500 17000 17800	25800 27500 30200	17.30 17.90 18.40	70	19400	15300	3.80
60	4.0	75/62 80/67 85/72	20600 21900 24100	16100 16600 18400	25500 27300 30000	15.70 16.20 16.60	70	21800	17900	4.10
70	4.0	75/62 80/67 85/72	20100 21400 23500	15700 16200 17000	25300 27000 29700	14.20 14.65 15.00	70	24200	20600	4.50
80	4.0	75/62 80/67 85/72	19500 20700 22800	15400 15900 16700	25100 26700 29400	12.60 13.00 13.30	70	26700	23400	4.90
90	4.0	75/62 80/67 85/72	18800 20000 22000	15100 15600 16400	24800 26500 29200	11.10 11.50 11.80				
100	4.0	75/62 80/67 85/72	18100 19200 21100	14900 15400 16100	24600 26200 28900	9.60 9.90 10.20				
110	4.0	75/62 80/67 85/72	17200 18300 20100	14700 15200 15900	24400 26000 28600	8.20 8.50 8.80				

(1) Unit only
 (2) Requires anti-freeze solution

TABLE 8 CAPACITY AND EFFICIENCY APPLICATION RATINGS

HPV30B @ 1000 CFM		COOLING						HEATING			
EWT	GPM	HPD	EAT	TC	SC	THR	EER(1)	EAT	TH	TEA	COP(1)
30(2)	4.0	3.0	75/62 80/67 85/72	33300 35400 38900	23800 24600 25900	38800 41200 45300	20.1 20.7 22.1	70	15800	9800	2.82
40(2)	4.0	3.0	75/62 80/67 85/72	31100 33100 36400	22900 23700 24800	36900 39300 43200	17.7 18.8 19.5	70	19600	13400	3.12
50	4.0	3.0	75/62 80/67 85/72	29100 31000 34100	22000 22700 23800	35300 37600 41400	15.6 16.1 17.2	70	23400	17000	3.43
60	4.0	3.0	75/62 80/67 85/72	27400 29100 32000	21100 21800 22800	33900 36100 39700	13.9 14.3 15.2	70	26800	19400	3.61
70	4.0	3.0	75/62 80/67 85/72	25800 27400 30100	20300 20900 21900	32800 34900 38700	12.3 12.7 13.5	70	30000	22300	3.91
80	4.0	3.0	75/62 80/67 85/72	24300 25900 28500	19500 20100 21000	31700 33700 37100	10.9 11.3 12.0	70	32900	25100	4.24
90	4.0	3.0	75/62 80/67 85/72	23100 24000 27100	18700 19200 20200	30900 32900 36200	9.7 10.1 10.8				
100	4.0	3.0	75/62 80/67 85/72	22100 23500 25900	18000 19200 19400	30500 32400 35600	8.8 9.0 9.5				
110	4.0	3.0	75/62 80/67 85/72	21200 22600 24900	17200 17700 18600	30100 32000 35200	7.9 8.2 8.8				

(1) Unit only
 (2) Requires anti-freeze solution

TABLE 9 CAPACITY AND EFFICIENCY APPLICATION RATINGS

HPV36B @ 1200 CFM		COOLING					HEATING				
BWT	GPM	HPD	EAT	TC	SC	THR	ERR(1)	EAT	TH	THA	COP(1)
30(2)	5.0	2.0	75/62	43700	30600	49200	19.3	70	27300	14900	3.05
			80/67	47600	31600	55400	19.9				
			85/72	51100	33100	72200	21.2				
40(2)	5.0	2.0	75/62	41000	29300	48300	17.1	70	30500	20000	3.2
			80/67	44100	30200	52600	17.6				
			85/72	48000	31700	63100	18.7				
50	5.0	2.0	75/62	38500	28000	47100	15.1	70	33600	23600	3.37
			80/67	41000	28900	50100	15.6				
			85/72	45100	30300	55600	16.6				
60	5.0	2.0	75/62	36100	26800	51200	13.3	70	37800	28300	3.6
			80/67	38300	27600	47800	13.7				
			85/72	42300	29000	49800	14.6				
70	5.0	2.0	75/62	33800	25600	44300	11.7	70	42000	31439	3.79
			80/67	36000	26400	45700	12.1				
			85/72	39600	27700	50700	12.9				
80	5.0	2.0	75/62	31600	24500	42700	10.3	70	46500	33900	4.00
			80/67	34100	25200	43800	10.6				
			85/72	37000	26500	43300	11.3				
90	5.0	2.0	75/62	29600	23400	40800	9.2				
			80/67	32600	24100	42200	9.4				
			85/72	34600	25300	42500	10.1				
100	5.0	2.0	75/62	27600	22400	38900	8.2				
			80/67	31600	23100	40800	8.4				
			85/72	32300	24200	43500	9.0				
110	5.0	2.0	75/62	25800	21400	36700	7.5				
			80/67	30900	22100	39600	7.6				
			85/72	30100	23200	46100	8.2				

(1) Unit only

(2) Requires anti-freeze solution

TABLE 10 CAPACITY AND EFFICIENCY APPLICATION RATINGS

HPV53B @ 1550 CFM		COOLING					HEATING				
BWT	GPM	HPD	EAT	TC	SC	THR	ERR(1)	EAT	TH	THA	COP(1)
30(2)	6.0	2.0	75/62	57400	36300	67200	17.9	70	32000	20300	2.86
			80/67	61000	37800	71500	18.7				
			85/72	67200	40000	78600	20.0				
40(2)	6.0	2.0	75/62	55000	35600	65800	16.1	70	38300	26000	3.06
			80/67	58500	36800	70000	16.7				
			85/72	64400	38600	77000	17.9				
50	6.0	2.0	75/62	52600	34700	64400	14.5	70	44500	31600	3.26
			80/67	56000	35800	68500	15.0				
			85/72	61600	37600	75400	16.0				
60	6.0	2.0	75/62	50200	33800	63000	12.9	70	50800	37300	3.45
			80/67	53500	34900	67000	13.3				
			85/72	58800	36600	73800	14.2				
70	6.0	2.0	75/62	47900	33300	61700	11.6	70	57000	42900	3.65
			80/67	51000	34000	65600	11.9				
			85/72	56100	35700	72200	12.7				
80	6.0	2.0	75/62	45585	32000	60400	10.3	70	63300	48600	3.84
			80/67	48500	33200	64200	10.5				
			85/72	53400	34800	70700	11.3				
90	6.0	2.0	75/62	43300	31500	59100	9.2				
			80/67	46100	32400	62800	9.4				
			85/72	50700	34100	69100	10.1				
100	6.0	2.0	75/62	41000	30800	57800	8.2				
			80/67	43600	31700	61500	8.4				
			85/72	48000	33300	67600	9.2				
110	6.0	2.0	75/62	38800	30200	56600	7.4				
			80/67	41200	31100	60100	7.6				
			85/72	45300	32700	66200	8.4				

(1) Unit only

(2) Requires anti-freeze solution

TABLE 11 CAPACITY AND EFFICIENCY APPLICATION RATINGS

EWT	GPM	WPD	COOLING							HEATING		
			EAT	TC	SC	THR	EER(1)	EAT	TE	TEA	COP(1)	
30(2)	8.0	4.0	75/62	64900	44000	79600	15.9	70	37000	23600	2.70	
			80/67	69000	45400	84600	16.5					
			85/72	75900	47800	93100	17.7					
40(2)	8.0	4.0	75/62	62550	42900	77000	14.7	70	44500	30000	2.85	
			80/67	66500	44200	82600	15.3					
			85/72	73200	46500	90900	16.4					
50	8.0	4.0	75/62	60200	41700	75800	13.7	70	52000	36300	3.03	
			80/67	64000	43000	80600	14.1					
			85/72	70400	45200	88700	15.1					
60	8.0	4.0	75/62	57850	40600	73900	12.3	70	59500	42600	3.15	
			80/67	61500	41800	78600	12.7					
			85/72	67700	43900	86500	13.6					
70	8.0	4.0	75/62	55500	39400	72000	10.9	70	67000	49000	3.29	
			80/67	59000	40600	76600	11.2					
			85/72	64900	42600	84300	12.0					
80	8.0	4.0	75/62	53200	38300	70100	9.8	70	74500	55400	3.43	
			80/67	56500	39400	74600	9.9					
			85/72	62200	41300	82100	10.7					
90	8.0	4.0	75/62	50800	37100	68200	8.6					
			80/67	54000	38200	72600	8.8					
			85/72	60200	40000	99700	9.4					
100	8.0	4.0	75/62	48450	36000	66300	7.5					
			80/67	51500	37000	70600	7.6					
			85/72	56700	38700	77700	8.1					
110	8.0	4.0	75/62	46100	34800	64400	6.3					
			80/67	49000	35800	68600	6.4					
			85/72	53900	37400	75500	6.8					

(1) Unit only

(2) Requires anti-freeze solution

CAPACITY MULTIPLIER FACTORS

% of Rated Air Flow	-10	Rated +10
Total Btuh	0.975	1.0
Sensible Btuh	.95	1.0
		1.05

CORRECTION FACTORS FOR PERFORMANCE AT OTHER WATER FLOWS

Rated Flow Plus--GPM	HEATING		COOLING	
	BTUH	WATTS	BTUH	WATTS
2	1.00	98	1.01	1.00
4	1.01	97	1.03	1.01
6	1.02	96	1.05	1.02
8	1.02	95	1.06	1.02

ARI CERTIFIED PERFORMANCE RATINGS

Model	CFM/ESP	GPM	COOLING*				HEATING*			
			70 F. EWT	50 F. EWT	70 F. EWT	50 F. EWT	70 F. EWT	50 F. EWT		
MPV30B	1000/.50	4	27400	11.0	31000	13.8	30000	3.4	23400	3.0
MPV36B	1200/.26	5	36000	10.8	41000	13.7	42000	3.4	33600	3.0
MPV53B	1550/.40	6	51000	10.8	56000	13.4	57000	3.3	44500	3.0
MPV62B	1700/.28	8	59000	10.0	64000	12.5	67000	3.0	52000	2.7

(1) For 208V operation, deduct 600 Btu.

(2) For 208V operation, deduct 1,000 Btu.

*Rated in accordance with ARI Standard 325, "Standard for Ground Water Source Heat Pumps", which includes Watt allowance for water pumping. Cooling capacity based on 80°F. DB 67° WB entering air temperature. Heating capacity based on 70° DB entering air temperature.

COOLING

TABLE 12
Water Temperature Entering Water Coil °F

Model	Return Air Temperature	Pressure	30	35	40	45	50	55	60	65	70	75	80	85	90	95	100	105	110	
MPV24	75 deg. DB	Low Side	72	73	73	74	75	76	77	77	78	79	80	80	81	82	83	83	84	
	62 deg. WB	High Side	106	113	121	130	140	151	163	175	189	204	219	235	253	271	290	310	331	
	80 deg. DB	Low Side	76	77	78	79	80	81	82	83	84	84	85	85	86	87	88	88	89	90
	67 deg. DB	High Side	109	117	125	134	144	155	167	180	194	209	225	242	259	278	298	318	340	340
Rated CFM 800	85 deg. WB	Low Side	81	83	84	85	86	87	88	89	90	91	92	93	93	94	95	95	96	
	72 deg. DB	High Side	114	121	130	139	149	160	173	186	200	215	232	249	267	286	307	328	350	
	75 deg. DB	Low Side	70	70	71	71	71	71	72	72	72	72	72	73	73	73	74	74	74	
	62 deg. WB	High Side	100	111	123	134	145	156	168	179	190	201	213	225	235	246	258	269	280	
MPV308	80 deg. DB	Low Side	75	75	76	76	76	76	77	77	77	77	78	78	78	78	79	79	79	
	67 deg. WB	High Side	103	115	126	138	149	161	172	184	195	207	218	230	241	253	264	276	287	
	85 deg. DB	Low Side	81	81	82	82	82	82	83	83	83	83	84	84	84	84	85	85	85	
	72 deg. WB	High Side	106	118	130	142	154	166	178	190	202	214	226	238	250	262	274	286	298	
MPV36B	75 deg. DB	Low Side	59	60	61	61	62	63	64	64	65	66	67	67	68	69	70	70	71	
	62 deg. WB	High Side	103	113	124	140	146	157	168	179	190	201	212	223	234	245	256	267	278	
	80 deg. DB	Low Side	63	64	65	65	66	67	68	68	69	70	71	71	72	73	74	74	75	
	67 deg. WB	High Side	105	116	120	139	150	161	173	184	195	206	218	229	240	251	263	263	285	
Rated CFM 1200	85 deg. DB	Low Side	68	69	70	70	71	72	73	73	74	75	76	76	77	78	79	79	80	
	72 deg. WB	High Side	108	122	132	141	155	167	179	190	202	214	226	237	249	261	273	284	296	
	75 deg. DB	Low Side	61	62	63	65	65	66	67	68	69	70	71	72	72	74	75	76	77	
	62 deg. WB	High Side	107	119	132	141	156	168	193	205	205	217	230	242	254	266	279	291	303	
MPV53B	80 deg. DB	Low Side	66	67	68	69	70	71	72	73	74	75	76	77	78	79	80	81	82	
	67 deg. WB	High Side	110	123	135	148	160	173	185	198	210	223	235	248	260	273	285	298	310	
	85 deg. DB	Low Side	70	71	73	74	75	76	78	79	80	81	83	84	85	86	88	89	90	
	72 deg. WB	High Side	115	128	141	166	166	179	192	204	217	230	243	255	268	281	294	306	319	
MPV62B	75 deg. DB	Low Side	61	62	62	63	63	64	64	65	65	66	66	67	67	68	68	69	69	
	62 deg. WB	High Side	109	120	131	141	152	163	174	184	195	206	217	227	238	249	260	270	281	
	80 deg. DB	Low Side	65	66	66	67	67	68	68	69	69	70	70	71	71	72	72	73	73	
	67 deg. WB	High Side	112	123	134	145	156	167	178	189	200	211	222	233	244	255	266	277	288	
Rated CFM 1700	85 deg. DB	Low Side	70	71	71	71	72	73	73	74	74	75	75	76	76	77	77	78	78	
	72 deg. WB	High Side	115	127	138	150	161	173	184	196	207	219	230	242	253	265	276	288	299	

HEATING

TABLE 13
Water Temperature Entering Water Coil °F

Model	Return Air Temperature	Pressure	Water Temperature Entering Water Coil °F															
			30	35	40	45	50	55	60	65	70	75	80					
WPV24B	70 D.B.	Low Side	39	44	49	54	59	64	70	76	82	88	94					
Rated Flow			160	170	179	187	195	202	208	214	219	223	227					
Rate GPM 4.0			30	35	41	46	51	56	62	67	72	77	83					
Rated CFM 800	70 degree	Low Side	166	173	180	186	193	200	207	213	220	227	234					
WPV30B			33	38	43	47	52	57	62	66	71	76	81					
Rated Flow			191	198	206	213	220	227	235	242	249	256	264					
Rated GPM 4.0	70 degree	High Side	30	35	40	44	49	54	59	63	68	73	78					
Rated CFM 1000			181	190	199	207	216	225	234	242	251	260	269					
WPV36B			27	32	37	42	47	52	57	62	67	72	77					
Rated Flow	70 degree	Low Side	158	173	188	203	218	233	248	263	278	293	308					
Rate GPM 6.0			30	35	40	44	49	54	59	63	68	73	78					
Rated CFM 1200			181	190	199	207	216	225	234	242	251	260	269					
WPV53B	70 degree	High Side	27	32	37	42	47	52	57	62	67	72	77					
Rated Flow			158	173	188	203	218	233	248	263	278	293	308					
Rate GPM 8.0			30	35	40	44	49	54	59	63	68	73	78					
Rated CFM 1550	70 degree	Low Side	181	190	199	207	216	225	234	242	251	260	269					
WPV62B			27	32	37	42	47	52	57	62	67	72	77					
Rated Flow			158	173	188	203	218	233	248	263	278	293	308					
Rate GPM 10.0	70 degree	High Side	30	35	40	44	49	54	59	63	68	73	78					
Rated CFM 1700			181	190	199	207	216	225	234	242	251	260	269					
WPV62B			27	32	37	42	47	52	57	62	67	72	77					
Rated Flow	70 degree	Low Side	158	173	188	203	218	233	248	263	278	293	308					
Rate GPM 12.0			30	35	40	44	49	54	59	63	68	73	78					
Rated CFM 2000			181	190	199	207	216	225	234	242	251	260	269					

NOTE: On units which employ an optional domestic hot water heat exchanger, turn water pump switch to "off" before measuring refrigerant pressures.

Low side pressure + 2 PSIG
High side pressure + 5 PSIG

Tables are based upon rated CFM (airflow) across the evaporator coil and rated water flow rate through the water coil. If there is any doubt as to correct operating charge being in the system, the charge should be removed, system evacuated, and recharged to serial plate specifications.

	WPV30B	WPV36B	WPV53B	WPV62B
Flow rate required GPM water	4	5	6	8
Flow rate required GPM 15% propylene glycol	5.2	6.5	7.8	10.4
Flow rate required GPM 30% propylene glycol	6.4	8.0	9.6	12.8

REFER TO CONTROL CIRCUIT WIRING ON CONTROL PANEL COVER AND INSTALLATION INSTRUCTIONS FOR HOOK-UP OF OPTIONAL DUCT HEATER

SOLENOID VALVE (OPTIONAL)
KBR24GP1-24VAC

SET HEAT ANTICIPATOR AT
.45A FOR EITHER TYPE OF
WALL THERMOSTAT

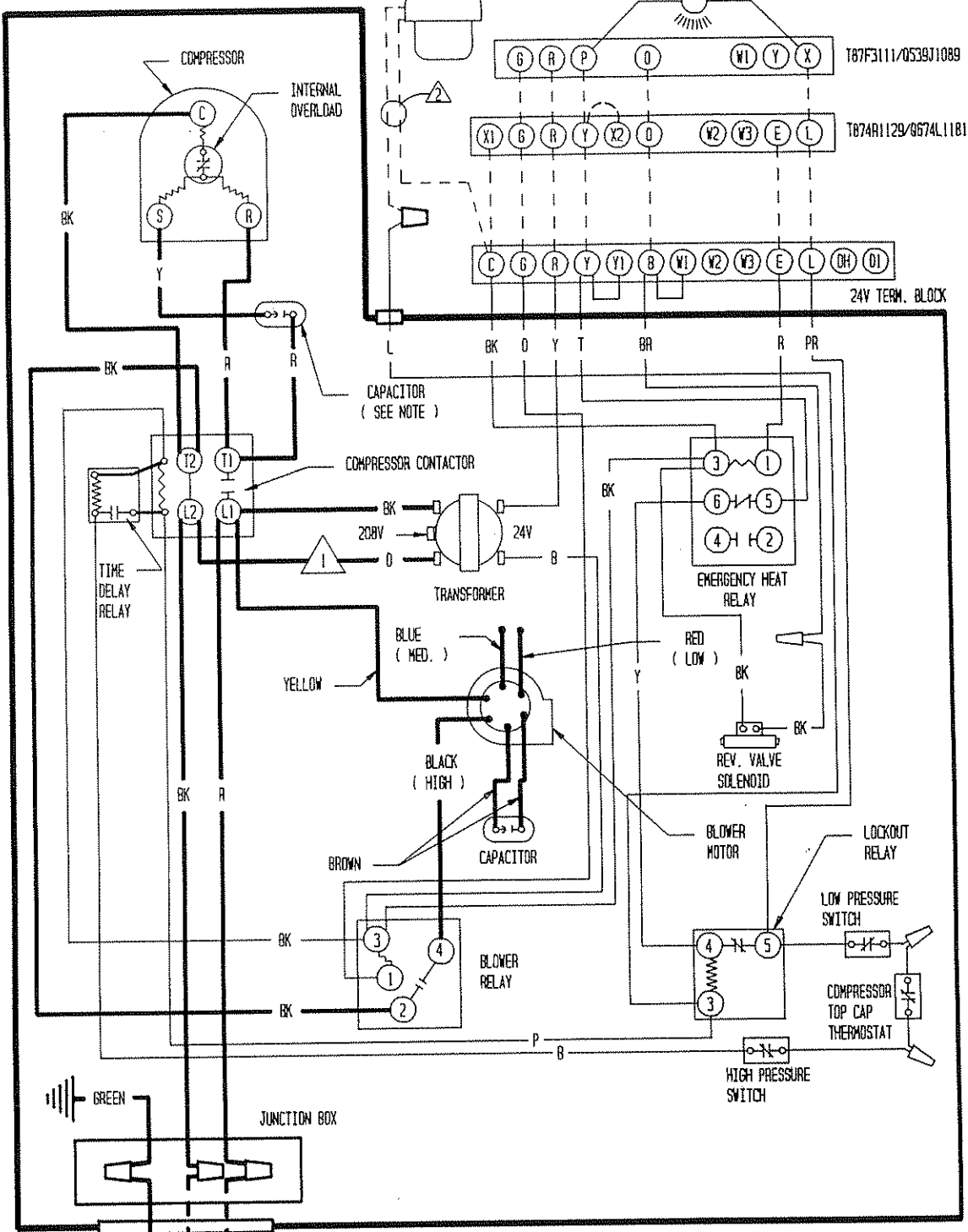

USE COPPER
CONDUCTORS ONLY

- ⚠ FOR 208V OPERATION MOVE THIS WIRE TO 208V TRANSFORMER TAP
- ⚡ USE WIRING RATED FOR USE IN NEC CLASS 1 SYSTEM

CAPACITOR RATINGS		
MODEL	COMPRESSOR	BLOWER
WPV24	25/370	5/370



230/208 - 60 - 1

REFER TO CONTROL CIRCUIT WIRING ON CONTROL PANEL COVER AND INSTALLATION INSTRUCTIONS FOR HOOK-UP OF OPTIONAL DUCT HEATER

SOLENOID VALVE (OPTIONAL)
KBR246 PI-24 VAL

SET HEAT ANTICIPATOR AT .45A FOR EITHER TYPE OF WALL THERMOSTAT

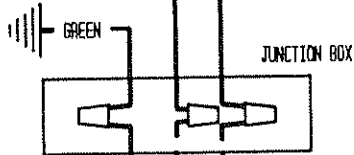
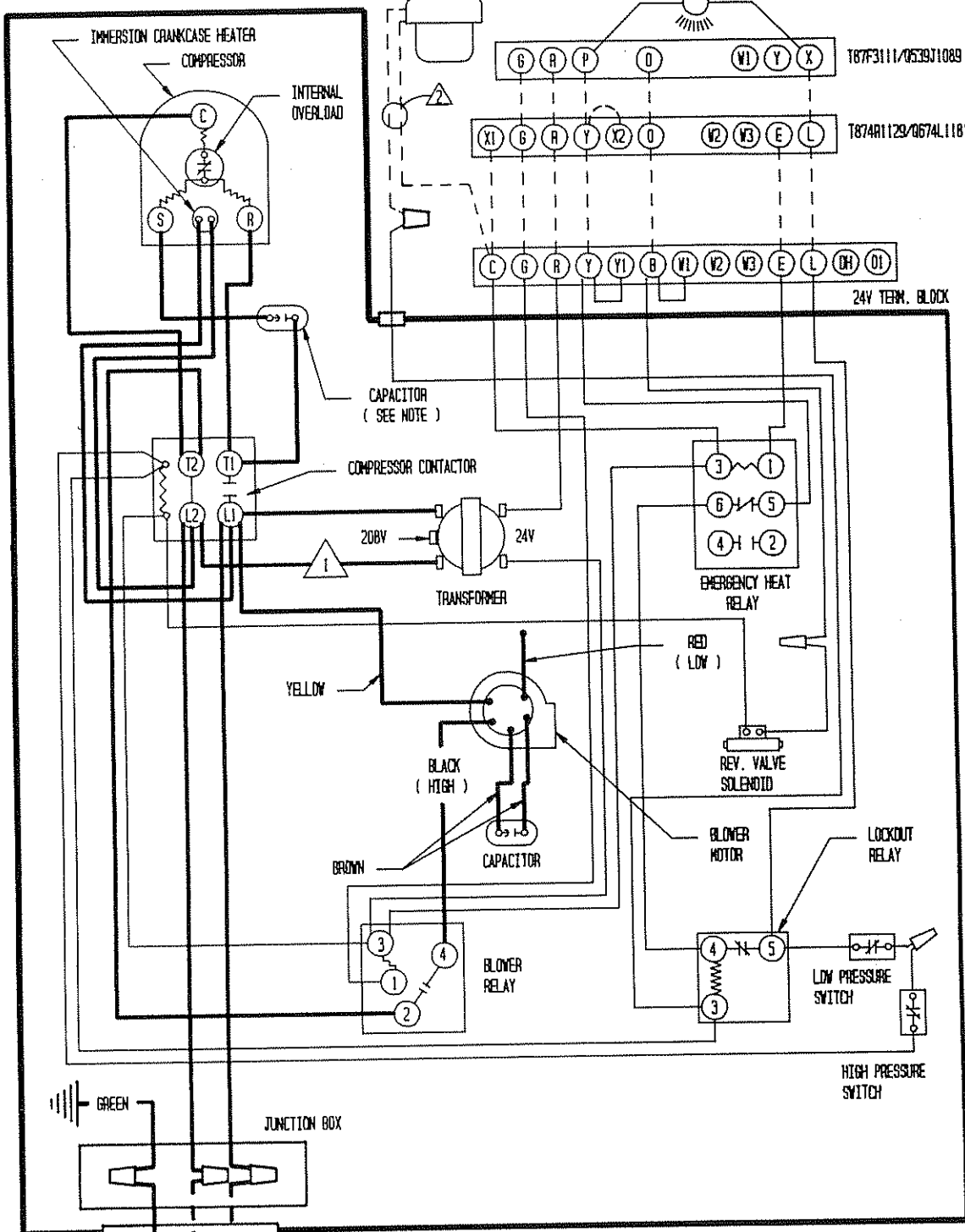

- ⚠ FOR 208V OPERATION MOVE THIS WIRE TO 208V TRANSFORMER TAP
- ⚠ USE WIRING RATED FOR USE IN NEC CLASS 1 SYSTEM

230/208 - 60 - 1

CAPACITOR RATINGS		
MODEL	COMPRESSOR	BLOWER
WPV30B	30/370	7-1/2/370
WPV36B	40/370	

USE COPPER CONDUCTORS ONLY



REFER TO CONTROL CIRCUIT WIRING ON CONTROL PANEL COVER AND INSTALLATION INSTRUCTIONS FOR HOOK-UP OF OPTIONAL DUCT HEATER

SOLENOID VALVE (OPTIONAL)
K.B.K24&P1-24VAC

CHECK LIGHT

SET HEAT ANTICIPATOR AT .45A FOR EITHER TYPE OF WALL THERMOSTAT

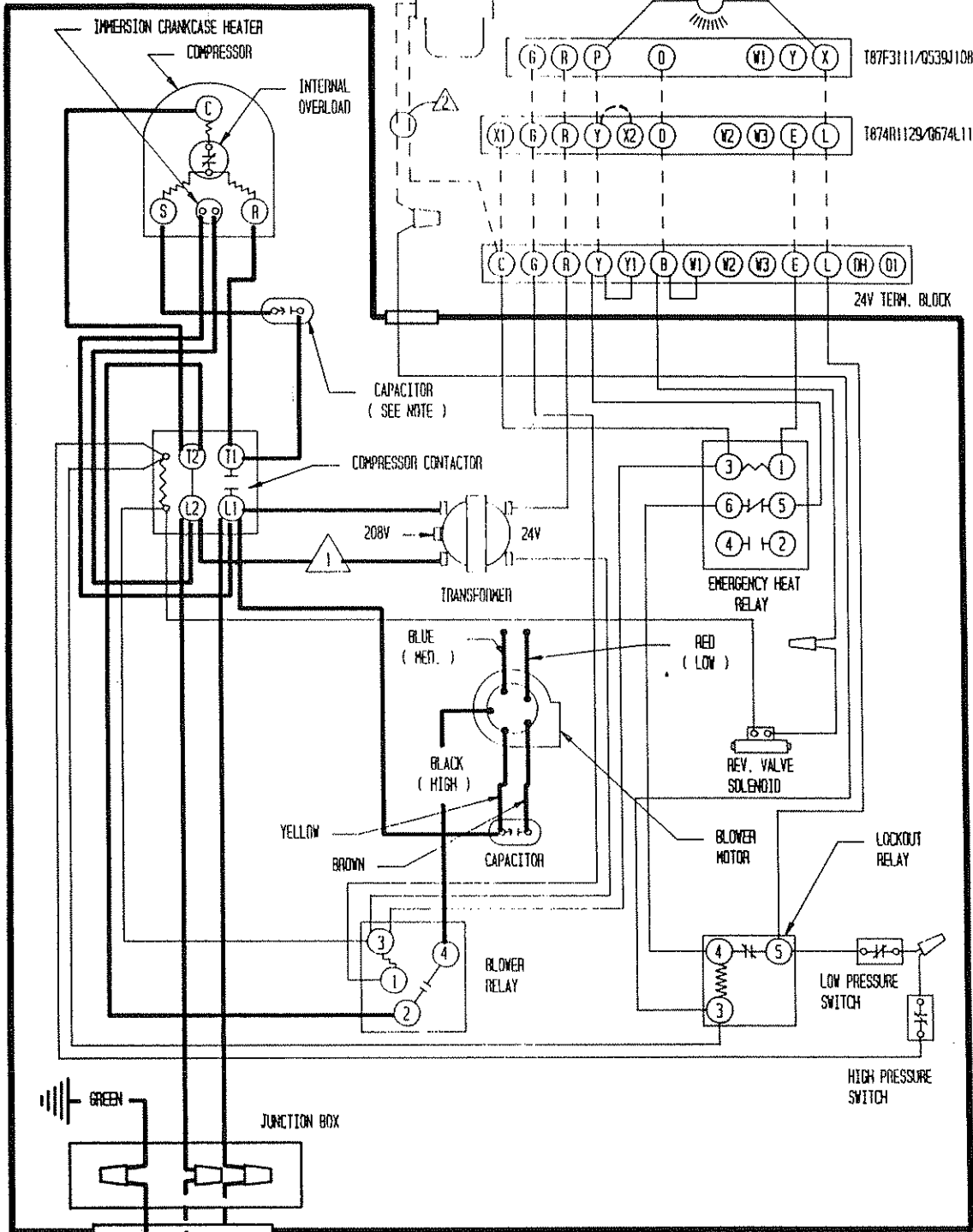

- ⚠ FOR 208V OPERATION MOVE THIS WIRE TO 208V TRANSFORMER TAP
- ⚠ USE WIRING RATED FOR USE IN NEC CLASS I SYSTEM

230/208 - 60 - 1

CAPACITOR RATINGS		
MODEL	COMPRESSOR	BLOWER
WPV53B	40/440	7.5/370
WPV62B	45/440	7.5/370

USE COPPER CONDUCTORS ONLY

	FACTORY WIRING	FIELD WIRING
Low Voltage	—	- - - -
High Voltage	—	- - - -

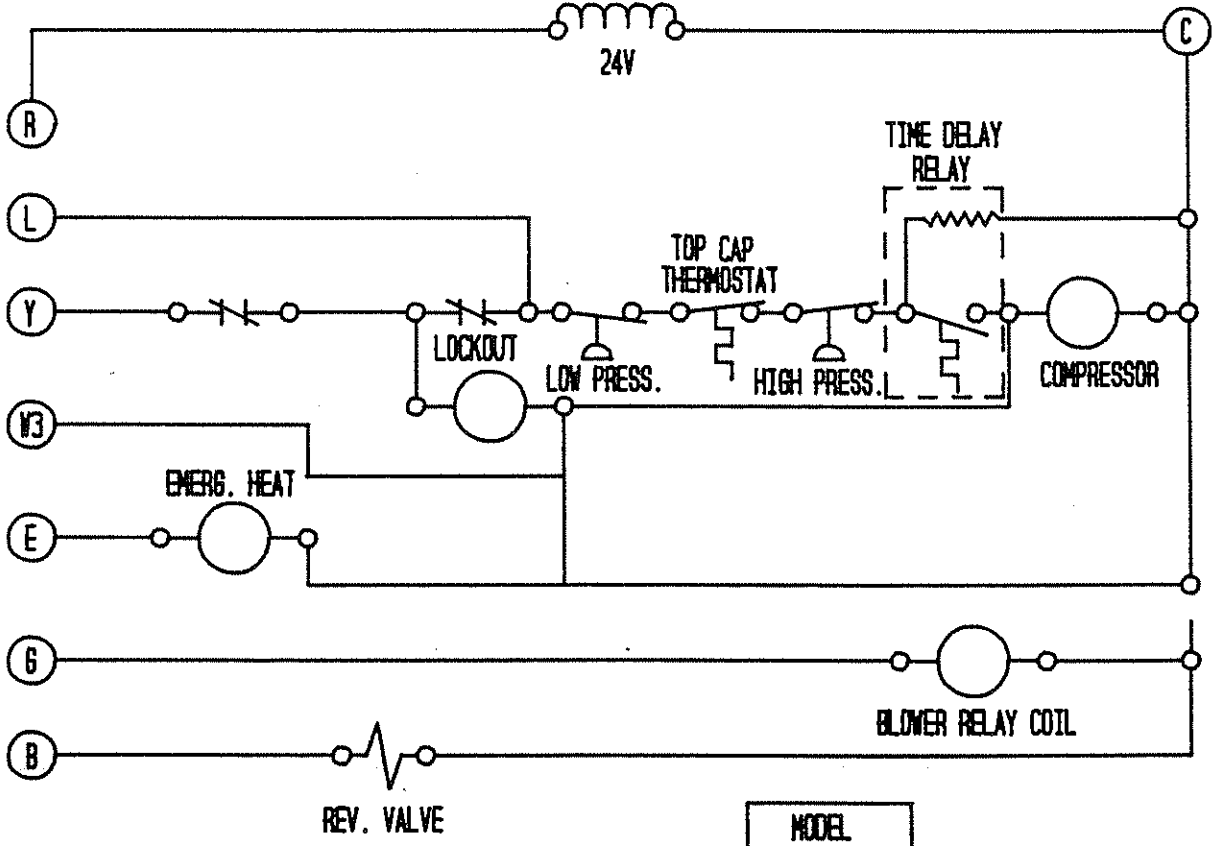
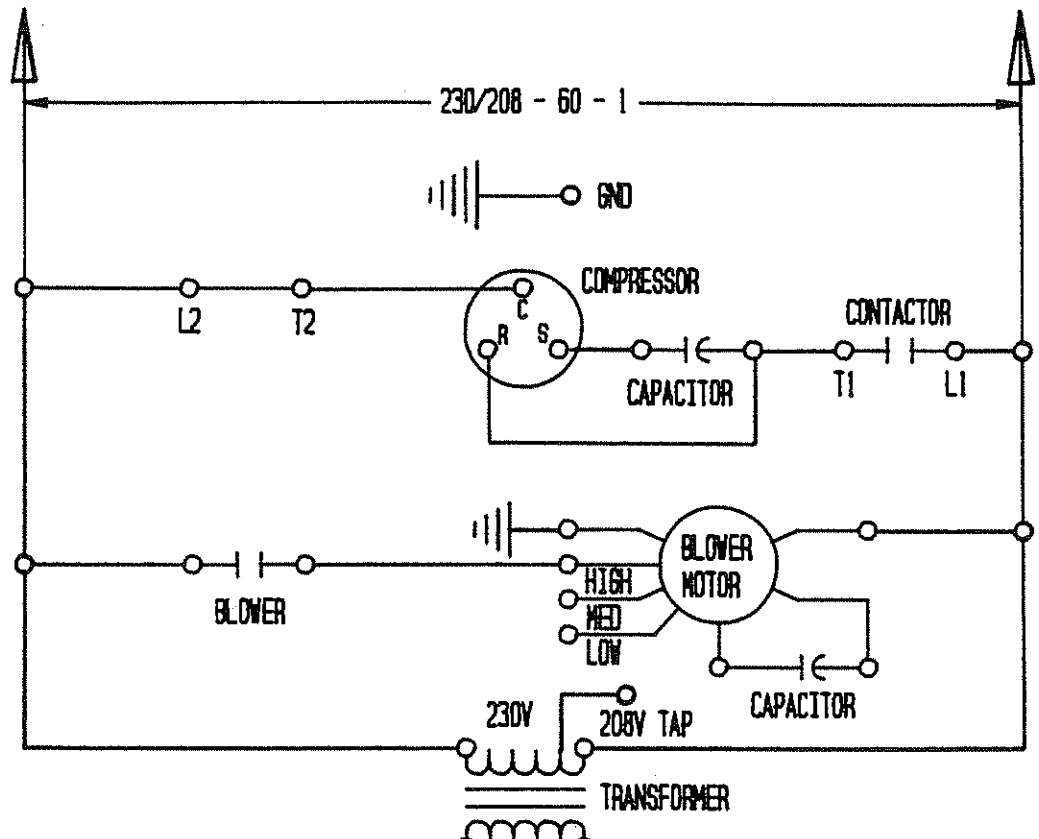

MODEL
WPV24

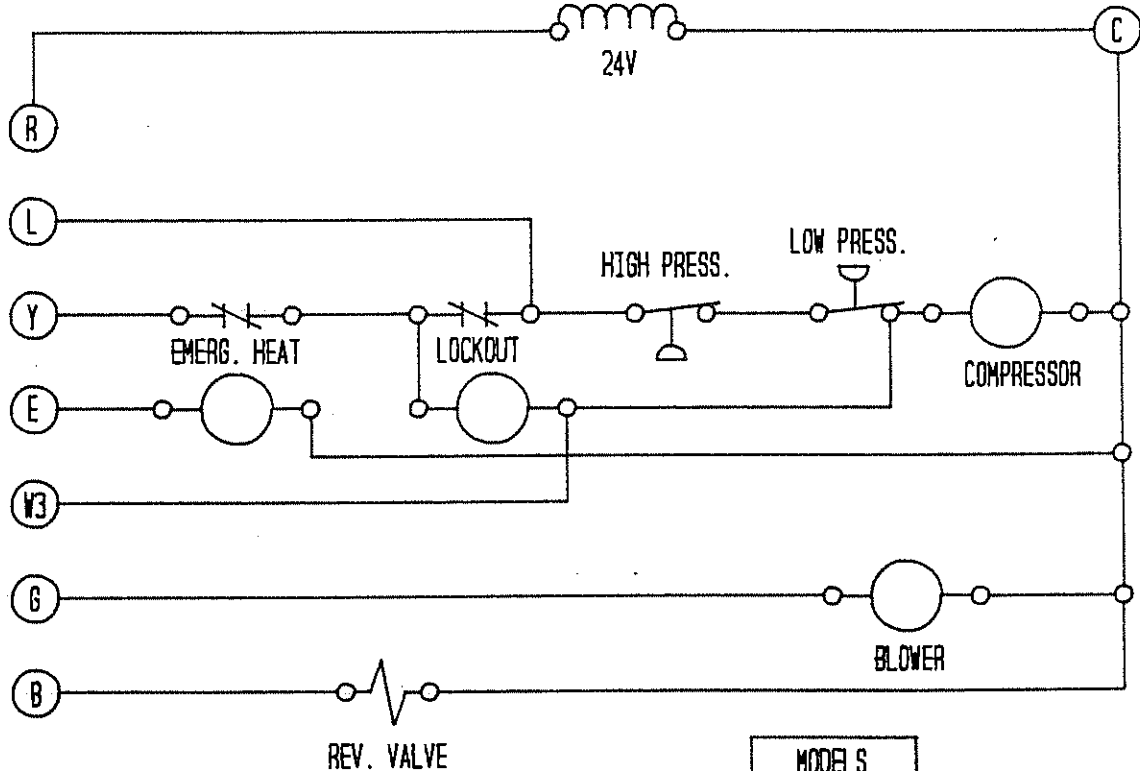
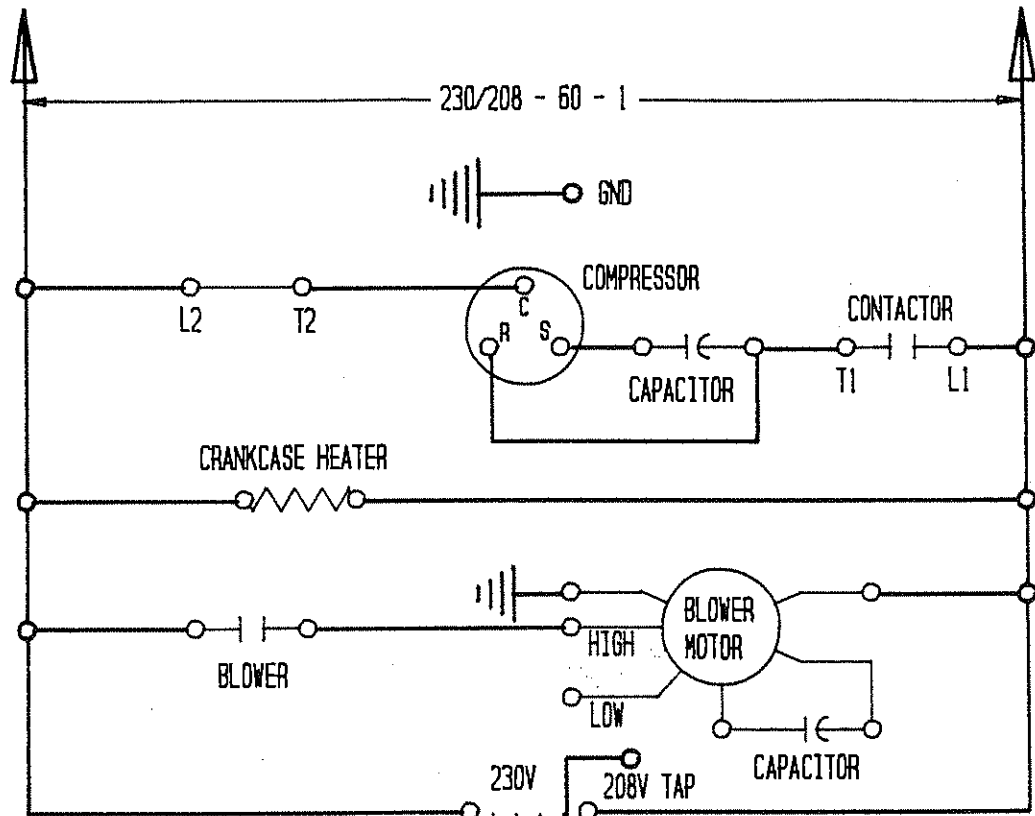

MODELS
WPV30B
WPV36B

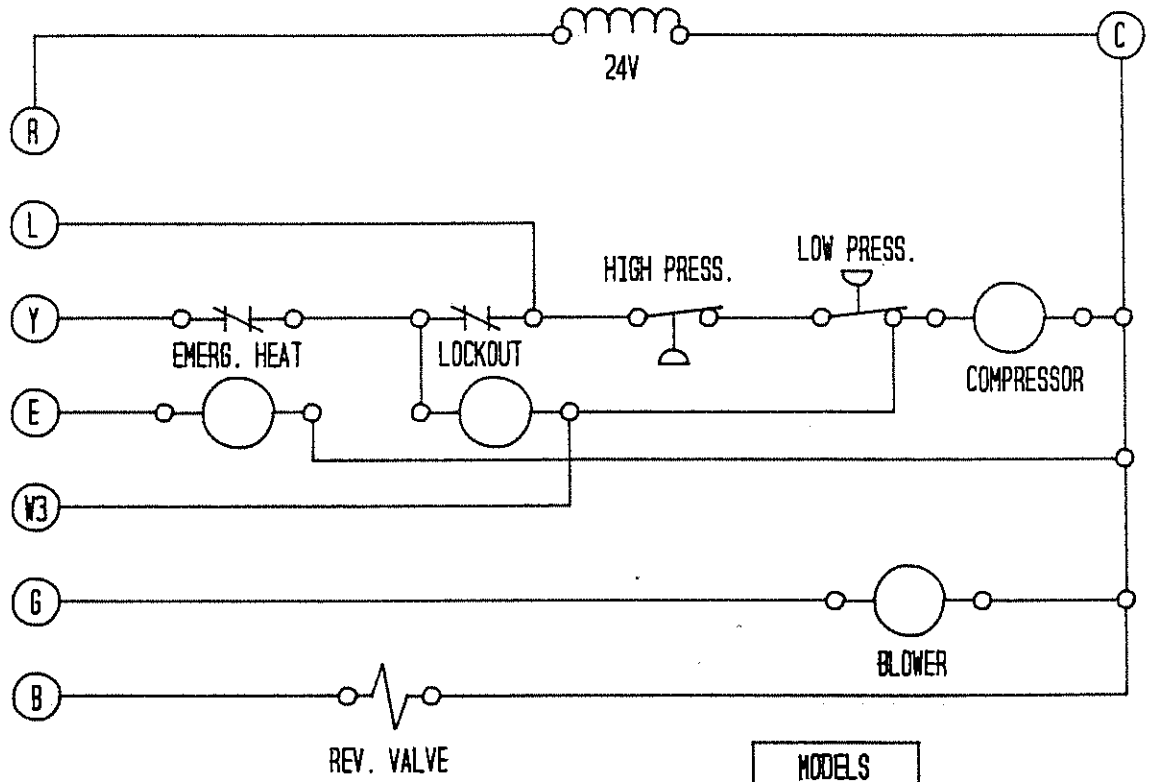
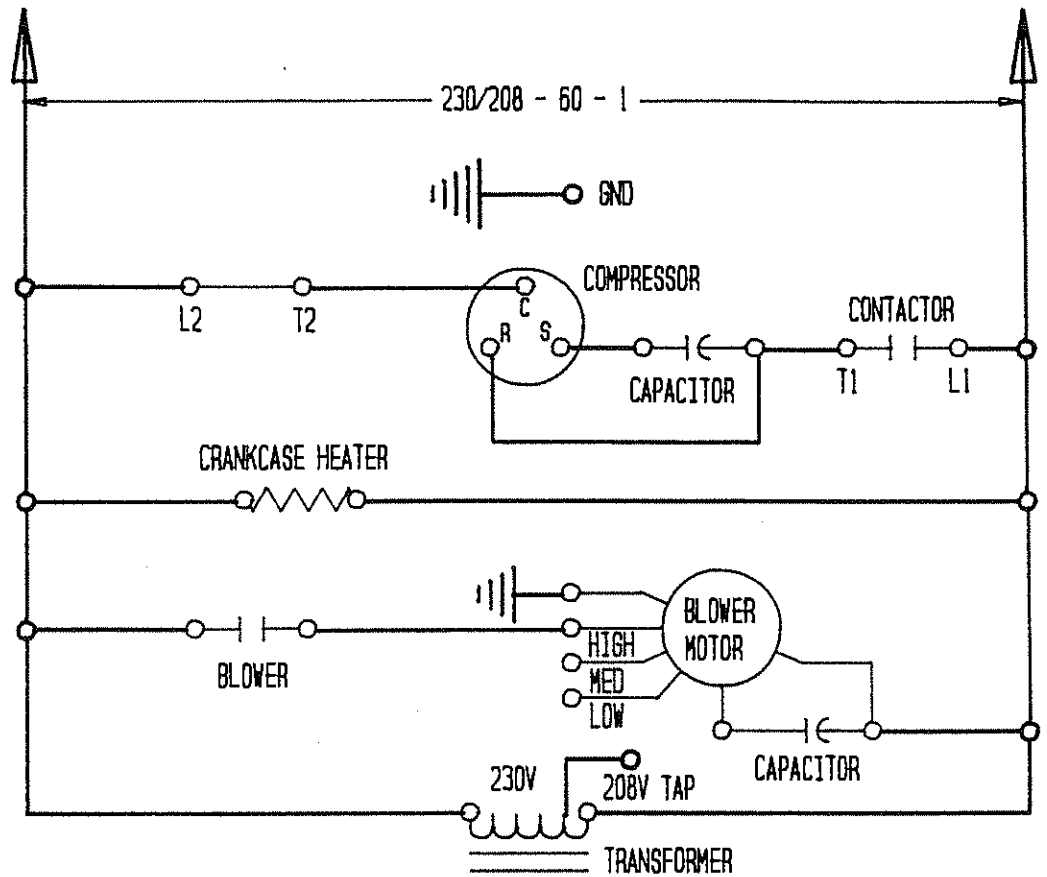

MODELS
WPV53B
WPV62B

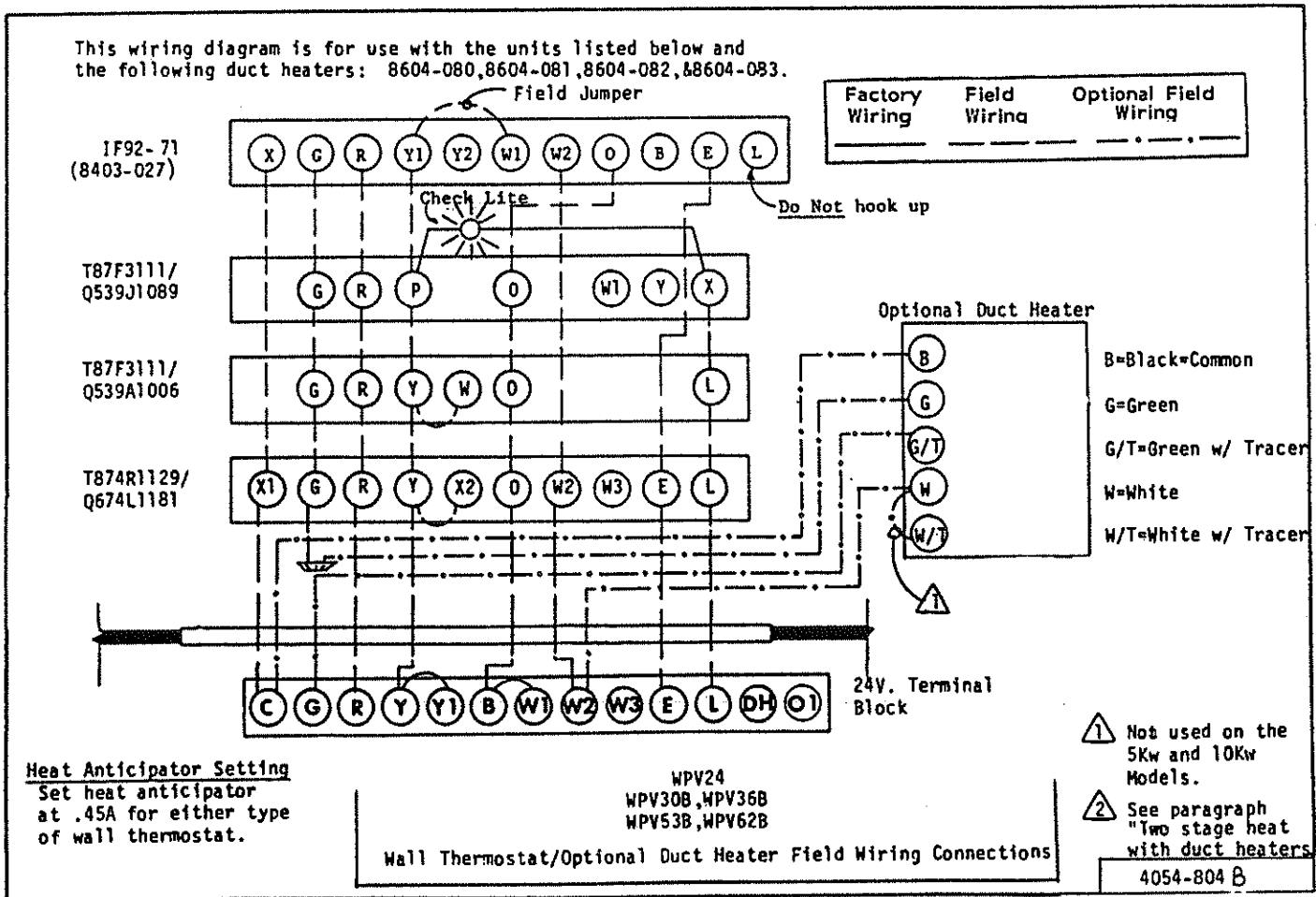
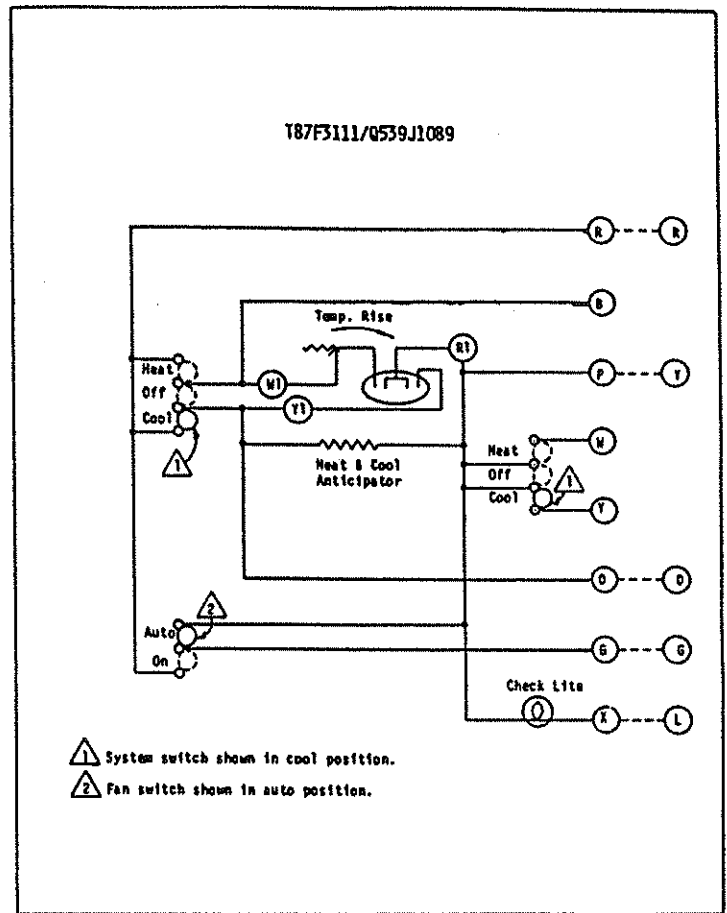
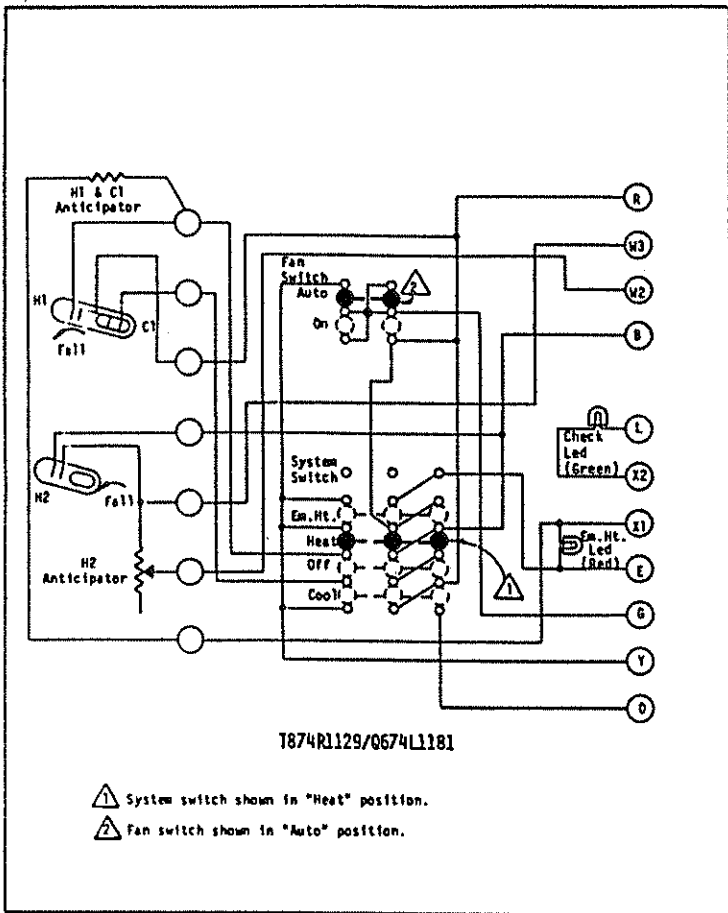

PERFORMANCE CHECK
WATER SOURCE HEAT PUMPS

Installer Please Fill Out
and Retain With Unit

DATE OF INSTALLATION _____ MODEL NO(S). _____ SERIAL NO(S). _____

ITEM	COOLING	HEATING	JOB NUMBER
1. HEAD PRESSURE			NAME OF INSTALLER
2. SUCTION PRESSURE			NAME OF OWNER
3. WATER TEMP. (IN)			ADDRESS
4. WATER TEMP. (OUT)			CITY STATE
5. WATER PRESSURE (IN)			FIELD COMMENTS:
6. WATER PRESSURE (OUT)			
7. WATER FLOW (GPM)			
8. AMPERES (BLOWER)			
9. AMPERES (COMPRESSOR)			
10. LINE VOLTAGE (COMPRESSOR RUNNING)			
11. AIR TEMP. (IN) D.B. W.B.			
12. AIR TEMP. (OUT) D.B. W.B.			

This PERFORMANCE CHECK SHEET should be filled out by
installer and retained with unit.