

INSTALLATION INSTRUCTIONS

SPLIT AIR CONDITIONER OUTDOOR SECTION

MODELS

24UACS,QB

30UACS,QA

36UACS,QA

36UACSA-B

42UACS,QA

42UACSA-B

48UACS,QA

48UACSA-B

60UACS,QA

60UACSA-B

**FOR USE WITH:
MATCHING INDOOR BLOWER
COIL UNITS AND MATCHING
ADD ON COIL UNITS ONLY**

COPYRIGHT JUNE, 1989
BARD MANUFACTURING COMPANY
BRYAN, OHIO

TABLE OF CONTENTS

I.	Application and Location	4
	General	4
	Shipping Damage	4
	Application	4
	Location	5
	Mounting Unit Outside on Slab	5
	Indoor Coil	5
	Important Installer Note	5
	Installing Refrigerant Tubing	5
	1. Precharged Tubing Connections	6
	2. Sweat Style Tubing Connections.	7
II.	Wiring Instructions	8
	General	8
	Crankcase Heaters	8
	Wall Thermostats	9
III.	Charging Instructions	9
	Pressure Service Ports	9
	System Start-Up	10
	Refrigerant Charge Checking	10
IV.	Service	13
	Service Hints	13
	Fan Blade Setting Dimensions	13
	Wiring Diagrams	14-15
	Pressure Tables	16-21

FIGURES AND TABLES

Figure 1	1
Figure 2	4
Figure 3	5
Figure 4	8
Figure 5	12

Table 1	1
Table 2	2
Table 3	3
Table 4	6
Table 5	7
Table 6	9
Table 7	9
Table 8	11
Table 9	11
Table 10	12
Table 11	13
Table 12	16
Table 13	17
Table 14	18
Table 15	19
Table 16	20
Table 17	21

FIGURE 1

NOMENCLATURE EXPLANATION - Example:

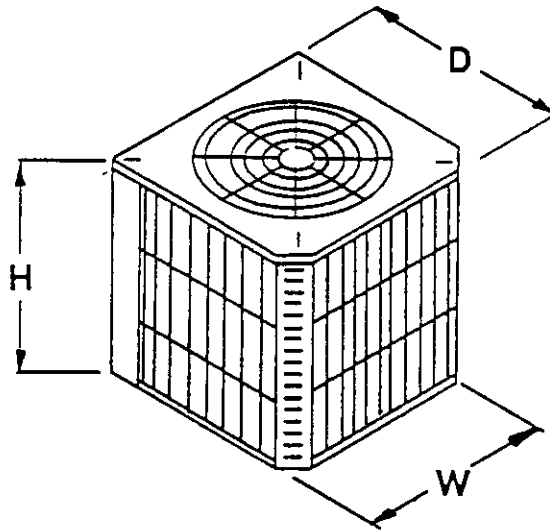
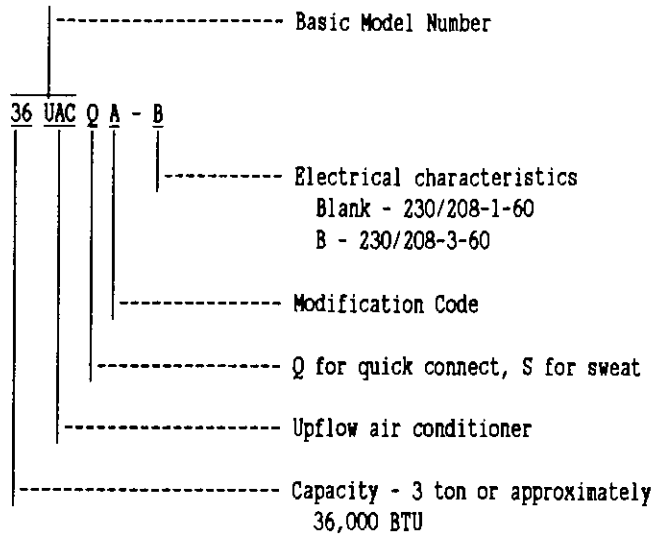

TABLE 1

DIMENSIONS			
Basic Model No.	"W" Width	"D" Depth	"H" Height
24UAC	32-1/2	32-1/2	26"
30UAC			
36UAC			
42UAC			
48UAC			
60UAC			36"

TABLE 2 RATED CFM AND AIR FLOW DATA (WET COIL--COOLING)

Condensing Unit Model Number	Evaporator Coil Model Number	Rated Airflow		Rated E.S.P. (2)	Motor Speed Tap	Recommended Air Flow Range	System Orifice Required
		CFM	Pressure Drop H2O (1)				
24UACQB 24UACSB	A18AQ-A	750	.20			640 - 825	.059
	A18AS-A						
	A30AQ-B	825	.15			700 - 910	.059*
	A30AQ-A	825	.15			700 - 910	.059
	A30AS-A						
30UACQA 30UACSA	BC24B	800		.35	High	700 - 910	.059
	3HCQ1	800	.20			680 - 880	--
	A30AQ-A	1000	.20			850 - 1100	.063
	A30AS-A						
	B36EQ1/BC35B	1025		.40	Low	870 - 1300	--
36UACQA 36UACSA 36UACSA-B	3HCQ1	1000	.30			850 - 1100	--
	BC30B	840		.20	High		.063
	BC36B	1050		.35	Low		.063*
	A30AQ-A	1125	.30			950 - 1240	.069*
	A30AS-A						
36UACQA 36UACSA 36UACSA-B	A36AQ-B	1200	.30			1020 - 1320	.072
	A36AQ-A	1200	.30			1020 - 1320	.069*
	A36AS-A						
	A42AQ-A	1380	.30			1170 - 1520	.069*
	A42AS-A						
	A48AQ-A	1450	.27			1230 - 1600	.069*
	A48AS-A						
	B36EQ1/BC35B	1200		.30	High	1020 - 1320	--
3HCQ1	950	.30			900 - 1050	--	
42UACQA 42UACSA 42UACSA-B	4HCQ	1300	.25			1170 - 1450	--
	BC36B	1200		.30	High	1020 - 1320	.072
	A42AQ-A	1325	.30			1125 - 1450	.078
	A42AS-A						
	A48AQ-A	1525	.30			1300 - 1675	.078*
	A48AS-A						
48UACQA 48UACSA 48UACSA-B	BC48A	1525		.20	Low	1300 - 1675	--
	BC60A	1640		.40	High	1400 - 1800	--
	4HCQ	1200	.30			1020 - 1320	--
	5HCQ	1500	.30			1275 - 1650	--
	BC36B	1200		.30	High	1020 - 1320	.078*
	A42AQ-A	1325	.30			1125 - 1450	.081*
48UACQA 48UACSA 48UACSA-B	A42AS-A						
	A48AQ-A	1525	.30			1300 - 1675	.081
	A48AS-A						
	BC48A	1700		.30	High	1450 - 1875	--
	BC60A	1750		.30	High	1485 - 1925	--
	4HCQ	1300	.30			1170 - 1450	--
60UACQA 60UACSA 60UACSA-B	5HCQ	1375	.30			1170 - 1450	--
	A48AQ-A	1500	.30			1275 - 1650	.092*
	A48AS-A						
	A60AQ-A	1900	.30			1615 - 2100	.092
	A60AS-A						
60UACQA 60UACSA 60UACSA-B	BC48A	1700		.30	High	1450 - 1875	--
	BC60A	1800		.20	High	1525 - 1975	--
	5HCQ	1600	.30			1360 - 1760	--

(1) Measured across the evaporator coil assembly, including drain pan.

(2) External static pressure available for the duct system - supply and return. All blower coils have multi-speed motors, and value shown is at the recommended rated speed. Consult specification air flow charts with the blower coil units for complete information at other speeds.

***IMPORTANT**

Proper sized orifice is not factory installed in indoor section. Proper orifice size is shipped with outdoor unit packaged with its installation instructions. The orifice must be replaced with the proper system orifice shown above in Table 2.

TABLE 3

ELECTRICAL DATA

MODEL	24UAC*B	30UAC*A	36UAC*A	36UACSA-B	42UAC*A	42UACSA-B	48UACQA	48UACSA-B	60UACQA	60UACSA-B
Electrical Rating--(60HZ/V/PH)	230/208-1	230/208-1	230/208-1	230/208-3	230/208-1	230/208-3	230/208-1	230/208-3	230/208-1	230/208-3
Operating Voltage Range	197 - 253	197 - 253	187 - 253	187 - 253	187 - 253	187 - 253	187 - 253	187 - 253	187 - 253	187 - 253
Minimum Circuit Ampacity	13	19	22	15	27	18	29	19	39	28
+Field Wire Size	#14	#12	#10	#14	#10	#12	#10	#12	#8	#10
++Delay Fuse Max. or Ckt. Bkr.	20	30	35	25	45	30	45	30	60	40
Total Unit Amps 230/208 Compressor	9.1/10.6	11.6/12.6	15.6/17.6	10.4/11.7	18/20.5	12.5/13.6	19.5/22	13.4/14.7	24.8/27.3	20.6/22.3
Rated Load Amps 230/208	8.1/9.5	10.5/11.7	14.5/16.5	8.9/10.3	16.5/19	11.0/12.1	18/20.5	11.9/13.2	22.5/25	18.3/20
Branch Ckt Selection Current	9.5	14.1	16.5	10.8	20.2	12.9	21.5	13.8	28.9	20
Lock Rotor Amps 230/208	49/49	66/66	75.8/75.8	65/65	93/93	74/74	95.4/95.4	82/82	138/138	103/103
Fan Motor & Condenser										
Fan Motor--HP/RPM		1/6 - 825					1/4 - 825		1/3 - 1075	
Fan Motor--Amps		1.1					1.5		2.3	
Fan--DIA/CFM		24" - 3000					24" - 3100		24" - 3100	
+60 deg. C copper wire size.										
++Maximum time delay fuse or HACR type circuit breaker										
*Applies to sweat and quick connect type.										

I. APPLICATION AND LOCATION

GENERAL

These instructions explain the recommended method to install the air cooled remote type condensing unit, the interconnecting refrigerant tubing, and the electrical wiring connections to the unit.

The condensing units are to be used in conjunction with the matching evaporator coils or evaporator blower units for comfort cooling applications as shown in the specification sheet.

These instructions and any instructions packaged with any separate equipment required to make up the entire air conditioning system should be carefully read before beginning the installation. Note particularly "Connecting Quick-Connect Couplings, Starting Procedure" and any tags and/or labels attached to the equipment.

While these instructions are intended as a general recommended guide, they do not supersede any national and/or local codes in any way. Authorities having jurisdiction should be consulted before the installation is made.

SHIPPING DAMAGE

Upon receipt of equipment, the carton should be checked for external signs of shipping damage. If damage is found, the receiving party must contact the last carrier immediately, preferably in writing, requesting inspection by the carrier's agent.

APPLICATION

Size of unit for a proposed installation should be based on heat loss calculation made according to methods of Air Conditioning Contractors of America. The air duct should be installed in accordance with the Standards of the National Fire Protection Association for the Installation of Air Conditioning and Ventilating Systems of Other Than Residence Type, NFPA No. 90A, and Residence Type Warm Air Heating and Air Conditioning Systems, NFPA 90B. Where local regulations are at a variance with instructions, installer should adhere to local codes.

FIGURE 2

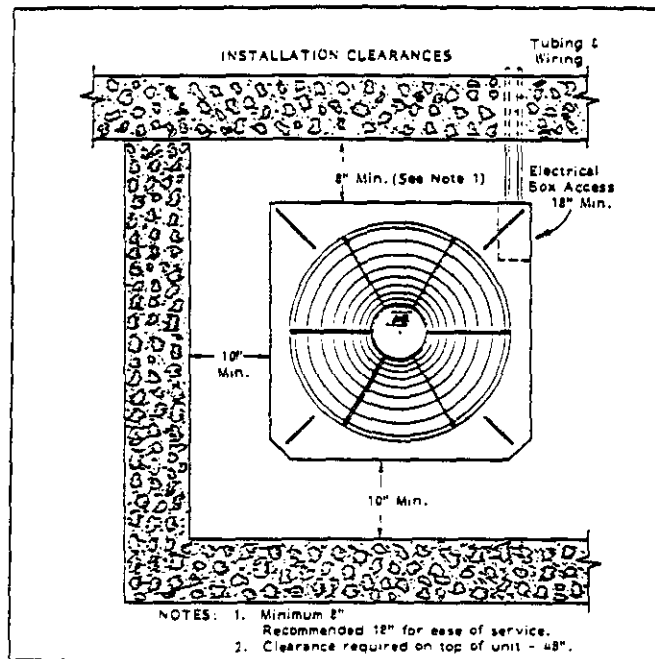

LOCATION

The condensing unit is designed to be located outside with free and unobstructed condenser air inlet and discharge. It must also permit access for service and installation. Condenser air enters the coil on three sides and discharges upward from the top. Refrigerant and electrical connections are made from the rear of the unit as shown in Figure 2 with electrical service access on the right side. The unit can be installed with the rear of the unit "close to the wall", however, additional service clearance at the back of the unit would be desirable if practical for unit service. The compressor can be serviced through the top.

MOUNTING UNIT OUTSIDE ON SLAB

A solid level base or platform, capable to support the unit's weight, must be set at the outdoor unit predetermined location. The base should be at least two inches larger than the base dimensions of the unit and at least two inches higher than surrounding grade level. The required unit minimum installed clearances must be maintained as called out in Figure 2 when locating and setting the base.

Remove the unit from its shipping carton and position the unit on the prepared base or platform.

Do not attach the unit or its base to the building structure to avoid the transmission of noise into the occupied area.

NOTE: These units employ internally sprung compressors; therefore, it is not necessary to remove or loosen the base mounting bolts on the compressor prior to operation.

Consideration should be given to the electrical and tubing connections when placing the unit to avoid unnecessary bends or length of material.

INDOOR COIL

These units are designed to match with all indoor blower coils, horizontal coils and "A" coils shown earlier in these instructions. All blower and horizontal coils are produced with capillary tube type refrigerant control. All "A" coils shown are produced with an interchangeable brass orifice to provide optimum matching of the refrigerant control when matching alternate sized "A" coils to the outdoor unit. A properly sized orifice for each outdoor section is packaged with this unit. See installation instructions packaged with the "A" coils for complete details.

IMPORTANT INSTALLER NOTE:

For improved start-up performance, wash the indoor coil with a dishwasher detergent.

INSTALLING REFRIGERANT TUBING

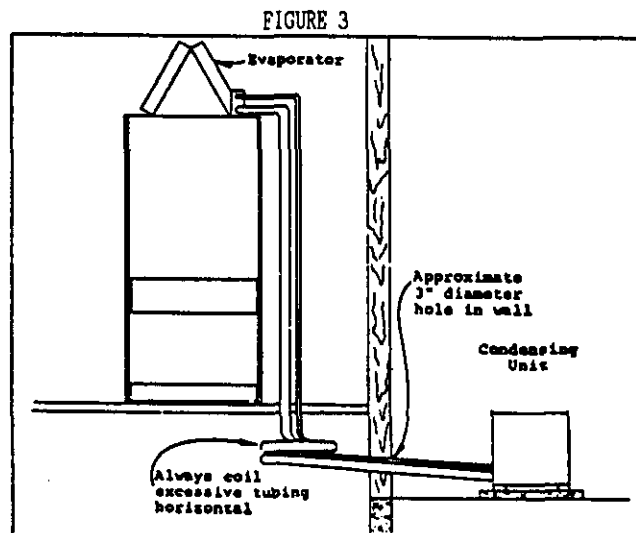

PRECHARGED TUBING CONNECTIONS 1

Examine carefully the two lengths of precharged tubing furnished with the system. The larger is the suction line and the smaller is the liquid line. The end of the tubing with the hex nut and gauge port is to be attached to the outdoor unit.

STEP 1--Unroll the tubing, being careful not to kink, and route both the suction line and liquid line between the indoor unit and outdoor unit.

Before fastening either end, use a tubing bender to make any necessary bends in tubing. When necessary to bend the insulated tube suction line, cut the insulation around its circumference at a distance far enough beyond the point of the bend so as to clear the tubing bender. Slip the insulation back together and vapor seal the joint with tape. Coil any excess tubing in a horizontal place with the slope of the tubing toward the condensing unit.

CAUTION: 1. Be careful not to tear the insulation when pushing it through holes in masonry or frame walls. 2. When sealing tube opening in house wall, use a soft material to prevent tube damper and vibration transmission. 3. Avoid excessive bending in any one place to avoid kinking.

STEP 2--Remove protector caps and plugs, inspect fittings and if necessary carefully wipe coupling seats and threaded surfaces with a clean cloth to prevent the inclusion of dirt or any foreign material in the system.

STEP 3--Lubricate male half diaphragm and synthetic rubber seal with refrigerant oil. Starting with the indoor coil thread coupling halves together by hand to insure proper mating of threads. Be sure to hold the coupling firmly to prevent movement of the coupling and tubing. Failure to do so could tear out the diaphragm causing a blockage of the system. Use proper size wrenches (on coupling body hex and on union nut) and tighten until coupling bodies "bottom" or a definite resistance is felt.

CAUTION: After starting to tighten up the fitting, never try to back it off or take it apart.

STEP 4--Using a marker or ink pen, mark a line lengthwise from the coupling union nut to the bulkhead. Then tighten an additional 1/4 turn: The misalignment of the line will show the amount the coupling has been tightened. This final 1/4 turn is necessary to insure the formation of leak proof joint. If a torque wrench is used, the following torque values are recommended:

TABLE 4

Coupling Size	Ft. Lbs.
-6	10 - 12
-10	35 - 45
-11	35 - 45
-12	50 - 65

Repeat Step 3 and 4 on outdoor section making sure to locate the gauge port in a 45 degree angle from a vertical up position so as to be accessible for gauge connections.

STEP 5--Leak test all connections using an electronic leak detector or a halide torch.

STEP 6--When tubing is installed in attics or drop ceilings, insulate the couplings on the larger tube thoroughly with 3/8" wall thickness, closed cell sponge tube insulation or equivalent. Failure to insulate will result in water damage to ceiling since the fitting will "sweat" and drop water on the ceiling.

1 NOTE: The maximum distance for precharged tubing between the outdoor and indoor unit is 45 feet.

SWBAT STYLE TUBING CONNECTIONS

TABLE 5

Basic Condensing Unit Model	Refrigerant Line Length (Ft.)		
	0 - 20	21 - 60	61 - 100
	Liquid & Suction	Liquid & Suction	Liquid & Suction
24UAC	3/8 & 5/8	3/8 & 3/4	3/8 & 3/4
30UAC	3/8 & 5/8	3/8 & 3/4	3/8 & 3/4
36UAC	3/8 & 5/8	3/8 & 3/4	1/2 & 7/8
42UAC	3/8 & 3/4	3/8 & 7/8	1/2 & 7/8
48UAC	3/8 & 7/8	3/8 & 7/8	1/2 & 1-1/8
60UAC	3/8 & 7/8	3/8 & 7/8	1/2 & 1-1/8

Use only refrigeration grade (dehydrated and sealed) copper tubing. care must be taken to insure that the tubing is kept clean and dry before and during installation. Do not remove the plugs from the tubing ends, coil connections or base valves until the connection is ready to be brazed.

The suction line must be insulated with a minimum of 3/8" Armaflex or equivalent before cutting and making connections.

STEP 1--Being careful not to kink, route both the suction line and liquid line between the indoor unit and outdoor unit. Use a tubing bender to make any necessary bends in tubing. When necessary to bend the insulated tube suction line, cut the insulation around its circumference at a distance far enough beyond the point of the bend so as to clear the tubing bender. Slip the insulation back together and vapor seal the joint with tape. Coil any excess tubing in a horizontal place with the slope of the tubing toward the condensing unit.

CAUTION: 1. Be careful not to tear the insulation when pushing it through holes in masonry or frame walls. 2. When sealing tube opening in house wall, use a soft material to prevent tube damage and vibration transmission. 3. Avoid excessive bending in any one place to avoid kinking.

STEP 2--The tubing ends should be cut square. Make sure it is round and free of burrs at the connecting ends. Clean the tubing to prevent contaminants from entering the system.

STEP 3--Wrap a wet rag around the copper stub before brazing.

STEP 4--Flux the copper tube and insert into the stub. Braze the joint using an alloy of silver or copper and phosphorus with a melting temperature above 1100 degrees F for copper to copper joints. The phosphorus will act as a flux, therefore, no flux will be required.

A copper-silver ally with a high silver content should be used when iron or steel material is involved in the joint. These alloys require the use of silver solder flux. Alloys containing phosphorus should not be used with iron or steel. Phosphorus reacts with the iron, forming iron phosphate which is extremely brittle.

CAUTION: 1. Brazing alloys with a melting temperature below 700 degrees F should not be used. 2. Lead-tin or tin-antimony solders should not be used due to their low melting point and necessity for corrosive fluxes.

To further prevent the formation of copper oxide inside the tubing, dry nitrogen may be purged through the refrigerant system during brazing.

WARNING: Never purge or pressurize a system with oxygen. An explosion and fire will result.

STEP 5--After brazing, quench with wet rag to cool the joint and remove any flux residue.

STEP 6--Leak test all connections using an electronic leak detector or a halide torch.

II. WIRING INSTRUCTIONS

GENERAL

All wiring must be installed in accordance with the National Electrical Code and local codes. In Canada, all wiring must be installed in accordance with the Canadian Electrical Code and in accordance with the regulations of the authorities having jurisdiction. Power supply voltage must conform to the voltage shown on the unit serial plate. A wiring diagram of the unit is attached to the inside of the electrical cover. The power supply shall be sized and fused according to the specifications supplied. A ground lug is supplied in the control compartment for equipment ground.

The control circuit is a 24 volt circuit. "Typical" wiring diagrams illustrating some of the various circuits which could be encountered can be found in the installation instructions of the indoor section.

The unit rating plate lists a "Maximum Time Delay Fuse" or "HACR Type" circuit breaker that is to be used with the equipment. The correct size must be used for proper circuit protection and also to assure that there will be no nuisance tripping due to the momentary high starting current of the compressor motor.

CRANKCASE HEATERS

All models have an insertion well-type heater located in the lower section of the compressor housing. This is a self-regulating type heater that draws only enough power to maintain the compressor at a safe temperature.

Some form of crankcase heat is essential to prevent liquid refrigerant migrating to the compressor causing oil pump out on compressor start-up and possible valve failure due to compressing a liquid.

Refer to unit wiring diagram to find exact type of crankcase heater used.

The following decal is affixed to all outdoor units detailing start-up procedure. This is very important. Please read carefully.

FIGURE 4

IMPORTANT

THESE PROCEDURES MUST BE FOLLOWED AT INITIAL START-UP AND AT ANY TIME POWER HAS BEEN REMOVED FOR 12 HOURS OR LONGER.

TO PREVENT COMPRESSOR DAMAGE WHICH MAY RESULT FROM THE PRESENCE OF LIQUID REFRIGERANT IN THE COMPRESSOR CRANKCASE

1. MAKE CERTAIN THE ROOM THERMOSTAT IS IN THE OFF POSITION. (THE COMPRESSOR IS NOT TO OPERATE.)
2. APPLY POWER BY CLOSING THE SYSTEM DISCONNECT SWITCH. THIS ENERGIZES THE COMPRESSOR HEATER WHICH EVAPORATES THE LIQUID REFRIGERANT IN THE CRANKCASE.
3. ALLOW 4 HOURS OR 60 MINUTES PER POUND OF REFRIGERANT IN THE SYSTEM AS NOTED ON THE UNIT RATING PLATE WHICHEVER IS GREATER.
4. AFTER PROPERLY ELAPSED TIME THE THERMOSTAT MAY BE SET TO OPERATE THE COMPRESSOR.
5. EXCEPT AS REQUIRED FOR SAFETY WHILE SERVICING — DO NOT OPEN SYSTEM DISCONNECT SWITCH.

7-61 061

WALL THERMOSTATS

The following wall thermostats and subbases should be used as indicated, depending on the application.

TABLE 6

AIR CONDITIONING THERMOSTATS		
Part No.	Model No.	Description
8403-002	T87F3111	THERMOSTAT--1 stg. heat, adj. heater, Mercury
8404-003	Q539A1220	SUBBASE --System Heat-Off-Cool Fan: On-Auto
8403-008	ID51-605	THERMOSTAT--1 stg. cool, System w/Off Sw. Snap Action Fan: Auto-On
8403-009	IF56-318	THERMOSTAT--1 st. cool, 1 stg. heat, Adj. heater Mercury System: Heat-Off-Cool Fan: Auto-On
8403-019	T874C1000	THERMOSTAT--1 stg. cool, 2 stg. heat, Adj. heater, Mercury
8404-012	Q674A1001	SUBBASE --System: Heat-Auto-Cool Fan: Auto-On

III. CHARGING INSTRUCTIONS

PRESSURE SERVICE PORTS

High and low pressure service ports are installed on all units so that the system operating pressures can be observed. Pressure tables can be found later in the manual covering all models. It is imperative to match the correct pressure table to the unit by model number.

The pressure service ports on the split system heat pump are located on the interconnecting tubing quick connect fittings. An additional low side service port is located on the quick connect mounting plate for low side pressure during heating operation.

TABLE 7

CHARGED TUBING (For Use With "Q" Versions)					
Model No.	Stub Tube*	15'	25'	35'	45'
24UACQ	CTO*	CT15A	CT25A	CT35	CT45
30UACQ	3/8" & 3/4"	3/8" & 5/8"	3/8" & 3/4"	3/8" & 3/4"	3/8" & 3/4"
36UACQ					
42UACQ	CTO-12*	CT15-12	CT25-12	CT35-12	CT45-12
48UACQ	3/8" & 7/8"	3/8" & 7/8"	3/8" & 7/8"	3/8" & 7/8"	3/8" & 7/8"
60UACQ					
*1/2 Stub Kit available, order CTO-A or CTO-12A (For matching quick connect coils with sweat type outdoor units).					

SYSTEM START-UP

The outdoor section of the air conditioner units are shipped with a factory R-22 charge sufficient for the nominal (size for size) matching "A" coil when used with 25' of interconnecting tubing. The "Q" models utilize "quick connect" refrigerant connectors and the "S" models use base valves. The units are shipped with the base valves in the closed position to contain the refrigerant charge within the unit.

1. For "S" models, connect a vacuum pump to both base valve service ports.
2. Evacuate the tubing and evaporator to 500 microns or less for a minimum of 30 minutes. Close the valve to the pump and wait for 15 minutes. The vacuum should not rise above 800 microns. If it rises above 800 or if you are not able to obtain 500 micron vacuum, pressurize with R-22, leak check, repair any leaks and repeat step 2.
3. Close valve to the vacuum pump and disconnect. Break the vacuum by opening both the suction and liquid line base valves to the fully open position and connect service gauges for pressure check.
4. Close disconnect switch and set the thermostat to cool and the temperature to the highest setting.
5. Check for proper operation of the indoor fan and outdoor unit.
6. Check and adjust charge if necessary. Refer to charge checking section.

REFRIGERANT CHARGE CHECKING

1. After connecting the service gauges and allowing the unit to run for at least 10 minutes until pressures are stable, record the suction and discharge (liquid) pressure.
2. Install a thermometer on the suction line approximately 6" to 10" from the compressor on all models except the 60UAC models. On the 60UAC install the thermometer approximately 6" ahead of the suction line accumulator (between the accumulator and the indoor section).
3. Determine superheat.

Refer to Table 8 to determine the saturated suction temperature.

Suction line temperature (from step 2) _____

Minus saturated suction temperature - _____

Equals--superheat _____

4. Measure outdoor temperature and return air dry bulb and wet bulb temperature and refer to Table 9 to determine the proper superheat setting.
5. Adjust the charge to the proper superheat by adding charge to lower and removing charge to raise the superheat.
6. Check final system operating pressures by comparing to the pressure tables later in this manual.

TABLE 8

SATURATED SUCTION TEMPERATURE (R-22)	
Suction Pressure PSIG	Saturated Suction Temperature (Deg. F)
50	26
53	28
55	30
58	32
61	34
63	36
65	38
67	39
70	41
73	43
76	45
79	47
82	49
86	51

TABLE 9

SYSTEM SUPERHEAT				
Outdoor Ambient Temperature (Deg. F Dry Bulb)	Return Air Temperature Deg. F--Wet Bulb			
	59	63	67	71
105	1	1	5	
95	1	3	(8)	20
90	1	7	14	26
85	3	9	19	33
80	8	14	25	39
75	10	20	30	42

TABLE 10

TOTAL SYSTEM OPERATING CHARGE (Includes charge for the basic outdoor unit, indoor coil and 25' of interconnecting tubing)		
Outdoor Section	Indoor Section	Total R-22 Charge (Oz.)
24UAC*B	A18A*-A	63
	A30A*-A	73
	A30AQ-B	73
	BC24B	76
	3HCQ1	65
30UAC*A	A30A*-A	88
	B36EHQ1/BC35B	85
	BC30B	91
	BC36B	104
36UAC*A 36UACSA-B	A30A*-A	86
	A36AQ-B	96
	A36A*-A	96
	A42A*-A	99
	A48A*-A	110
	B36EHQ1/BC35B	92
	3HCQ1	89
	4HCQ	106
	BC36B	106
42UAC*A 42UACSA-B	A42A*-A	120
	A48A*-A	132
	BC48A	139
	BC60A	146
	BC36B	119
48UAC*A 48UACSA-B	A42A*-A	153
	A48A*-A	184
	BC48A	174
	BC60A	182
	4HCQ	205
	5HCQ	155
60UAC*A	A48A*-A	208
	A60A*-A	225
	BC48A	287
	BC60A	292
	5HCQ	264
60UACSA-B	A48A*-A	185
	A60A*-A	202
	BC48A	264
	BC60A	269
	5HCQ	241

The above includes 25' of 3/8" diameter liquid line. For other than 25' and other tube sizes, adjust the total charge according to the following schedule.

Liquid Line Diameter	Oz, R-22 Per Ft.
3/8"	.6
1/2"	1.2

INSTALLER NOTE: Stamp or mark the final system charge determined above on the outdoor unit serial plate.

Examples: 36UAC*A and A36A*-A with 35' liquid line
 $35' - 25' = 10' \times .6 = 6 \text{ oz.}$ $96 + 6 = 102 \text{ oz. Total}$

36UAC*A and A36A*-A with 18' liquid line
 $25' - 18' = 7' \times .6 = 4.2 \text{ oz.}$ $96 - 4 = 92 \text{ oz. Total}$

NOTE: Round all decimals to nearest whole number.

IV. SERVICE

SERVICE HINTS

1. Caution homeowner to maintain clean air filters at all times. Also, not to needlessly close off supply and return air registers. This reduces air flow through the system, which shortens equipment service life as well as increasing operating costs.
2. Switching to heating cycle at 75 degrees F or higher outside temperature may cause a nuisance trip of the reset high pressure switch.
3. The heat pump wall thermostats perform multiple functions. Be sure that all function switches are correctly set for the desired operating mode before trying to diagnose any reported service problems.
4. Check all power fuses or circuit breakers to be sure that they are the correct rating.
5. Periodic cleaning of the outdoor coil to permit full and unrestricted air flow circulation is essential.

FAN BLADE SETTING DIMENSIONS

Shown in the drawing below are the correct fan blade setting dimensions for proper air delivery across the outdoor coil.

Any service work requiring removal or adjustment in the fan and/or motor area will require that the dimensions below be checked and blade adjusted in or out on the motor shaft accordingly.

FIGURE 5

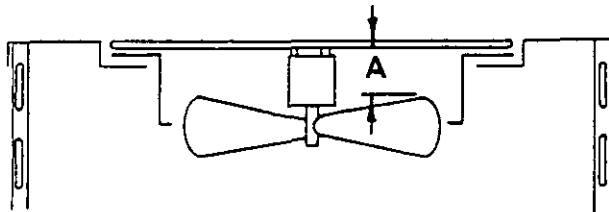
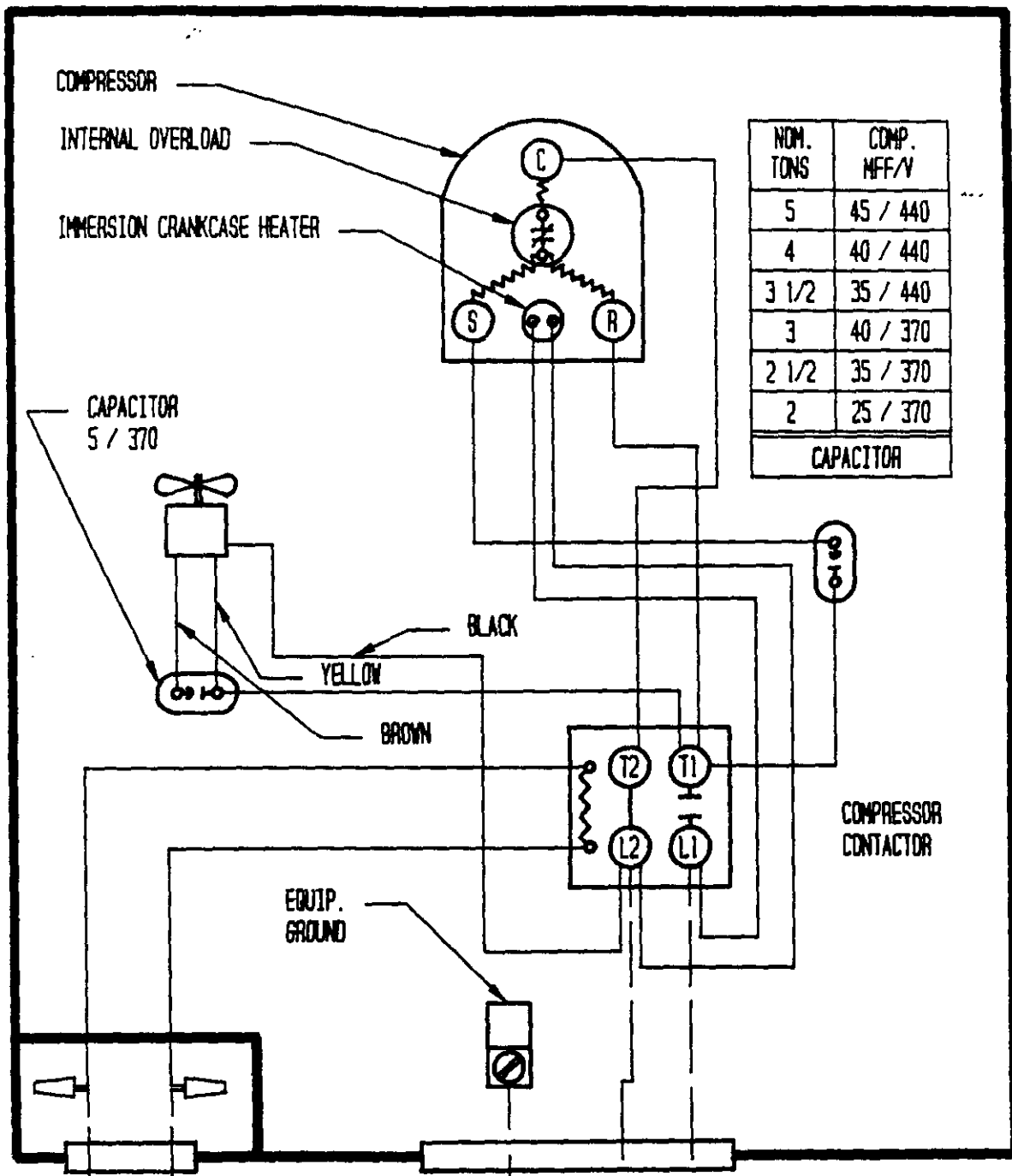

TABLE 11

Model	Dimension A
24, 30, 36 UAC	3-1/2
42, 48, 60UAC	4



NOM. TONS	COMP. MFF/V
5	45 / 440
4	40 / 440
3 1/2	35 / 440
3	40 / 370
2 1/2	35 / 370
2	25 / 370
CAPACITOR	

USE MINIMUM TRANSFORMER RATING OF 20 VA

24V

--- FIELD WIRING

— FACTORY WIRING

USE COPPER CONDUCTORS ONLY

FUSED DISCONNECT SWITCH

230 / 208-60-1

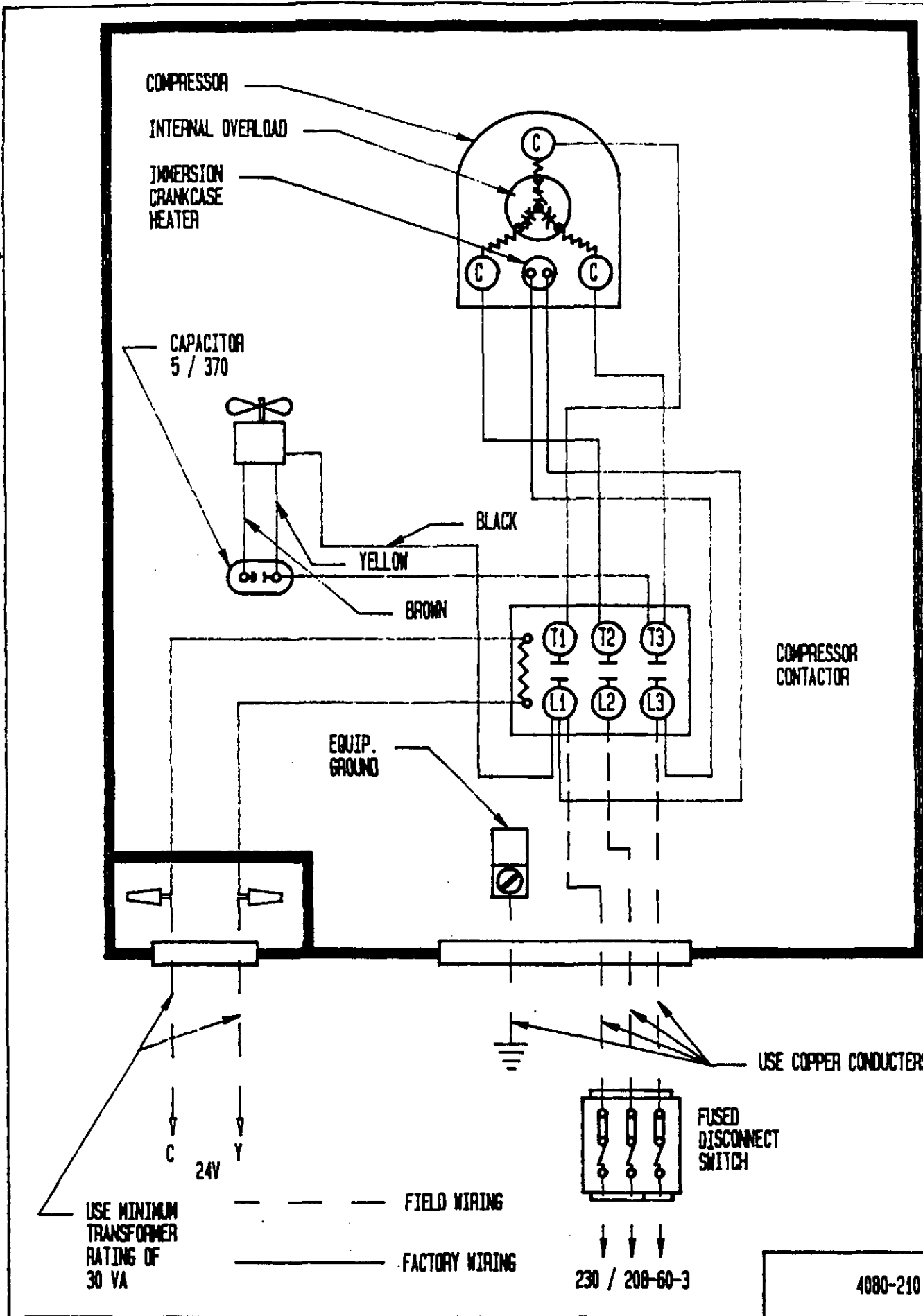

4080-210 A

TABLE 12

COOLING

Air Temperature Entering Outdoor Coil Degree F

Model	Return Air Temperature	Pressure	°	°	°	°	°	°	°	°	°
			75	80	85	90	95	100	105	110	115
A18AQ-A, A18AS-A Rated CFM 750	75 deg. DB	Low Side	63	65	67	69	71	73	74	76	77
	62 deg. WB	High Side	165	178	192	206	222	237	254	271	289
	80 deg. DB	Low Side	67	70	72	74	76	77	79	80	82
	67 deg. WB	High Side	169	183	197	212	228	244	261	278	297
	85 deg. DB	Low Side	72	74	77	79	82	83	85	86	88
	72 deg. WB	High Side	176	190	204	220	236	252	270	288	307
A30AQ-A, A30AS-A A30AQ-B Rated CFM 825	75 deg. DB	Low Side	69	72	74	76	78	79	80	82	83
	62 deg. WB	High Side	176	189	203	217	233	248	265	282	301
	80 deg. DB	Low Side	73	76	79	81	84	85	87	88	89
	67 deg. WB	High Side	181	194	208	223	239	255	272	290	309
	85 deg. DB	Low Side	80	82	85	87	90	91	93	94	95
	72 deg. WB	High Side	187	201	215	230	247	263	281	300	320
3HCQ1 Rated CFM 800	75 deg. DB	Low Side	69	71	73	75	77	78	80	82	84
	62 deg. WB	High Side	162	176	190	205	221	236	252	269	286
	80 deg. DB	Low Side	73	75	78	80	83	85	86	88	90
	67 deg. WB	High Side	166	181	196	211	227	242	259	275	293
	85 deg. DB	Low Side	79	81	84	86	89	91	92	94	96
	72 deg. WB	High Side	176	190	204	219	235	251	267	285	303
BC24B Rated CFM 800	75 deg. DB	Low Side	73	75	77	78	80	81	82	83	84
	62 deg. WB	High Side	175	188	202	216	232	247	263	280	298
	80 deg. DB	Low Side	77	80	82	84	86	87	88	89	90
	67 deg. WB	High Side	179	193	207	222	238	254	270	287	306
	85 deg. DB	Low Side	83	86	88	90	92	93	94	96	97
	72 deg. WB	High Side	186	200	214	230	246	262	280	298	317

Low side pressure \pm 2 PSIG (suction line @ outdoor unit quick connect)
High side pressure \pm 5 PSIG (liquid line @ outdoor unit quick connect)

Tables are based upon rated CFM (airflow) across the evaporator coil and should be found under section titled "Refrigerant Charge" elsewhere in manual. If there is any doubt as to correct operating charge being in the system, the charge should be removed, system evacuated, and recharged to serial plate instructions.

30UACQA
30UACSA

TABLE 13

COOLING

Air Temperature Entering Outdoor Coil Degree F

Model	Return Air Temperature	Pressure	Air Temperature Entering Outdoor Coil Degree F								
			75	80	85	90	95	100	105	110	115
A30AQ-A, A30AS-A Rated CFM 1000	75 deg. DB	Low Side	66	68	70	72	74	75	78	80	82
	62 deg. WB	High Side	182	197	212	227	242	257	272	287	302
	80 deg. DB	Low Side	71	73	75	77	79	81	83	85	87
	67 deg. WB	High Side	186	202	217	233	248	263	279	294	310
	85 deg. DB	Low Side	77	79	81	83	85	87	89	91	93
	72 deg. WB	High Side	192	209	225	241	257	273	289	305	322
3HCQ1 Rated CFM 1000	75 deg. DB	Low Side	66	68	70	72	74	76	78	80	82
	62 deg. WB	High Side	174	190	205	221	236	251	267	282	298
	80 deg. DB	Low Side	71	73	75	77	79	81	83	85	87
	67 deg. WB	High Side	179	195	210	226	242	258	274	289	305
	85 deg. DB	Low Side	77	79	81	83	85	87	89	91	93
	72 deg. WB	High Side	185	202	218	234	250	266	282	298	315
B36EQ1/ BC35B Rated CFM 1025	75 deg. DB	Low Side	65	67	69	71	73	75	77	79	81
	62 deg. WB	High Side	175	189	204	218	233	248	262	277	291
	80 deg. DB	Low Side	70	72	74	76	78	80	82	84	86
	67 deg. WB	High Side	179	194	209	224	239	254	269	284	299
	85 deg. DB	Low Side	73	76	79	81	84	87	89	92	95
	72 deg. WB	High Side	185	201	216	231	247	262	278	293	309
BC30B Rated CFM 840	75 deg. DB	Low Side	64	67	70	72	74	76	77	78	79
	62 deg. WB	High Side	185	198	213	227	243	259	276	294	312
	80 deg. DB	Low Side	69	72	75	77	79	81	82	84	85
	67 deg. WB	High Side	188	203	218	250	250	267	284	302	320
	85 deg. DB	Low Side	73	77	80	83	85	87	89	90	91
	72 deg. WB	High Side	194	210	226	242	259	276	294	312	331
BC36B Rated CFM 1050	75 deg. DB	Low Side	69	71	73	75	77	79	80	82	83
	62 deg. WB	High Side	186	201	216	231	247	263	279	296	313
	80 deg. DB	Low Side	74	76	78	80	82	84	86	87	89
	67 deg. WB	High Side	190	222	238	238	254	271	287	305	322
	85 deg. DB	Low Side	80	82	84	86	88	90	92	94	96
	72 deg. WB	High Side	196	212	229	246	263	280	298	315	333

Low side pressure + 2 PSIG (suction line @ outdoor unit quick connect)
High side pressure + 5 PSIG (liquid line @ outdoor unit quick connect)

Tables are based upon rated CFM (airflow) across the evaporator coil and should be found under section titled "Refrigerant Charge" elsewhere in manual. If there is any doubt as to correct operating charge being in the system, the charge should be removed, system evacuated, and recharged to serial plate instructions.

Model	Return Air Temperature	Pressure	Air Temperature Entering Outdoor Coil Degree F								
			75	80	85	90	95	100	105	110	115
A30AQ-A, A30AS-A Rated CFM 1125	75 deg. DB	Low Side	59	61	63	66	68	70	73	75	77
	62 deg. WB	High Side	176	190	203	217	230	243	257	270	284
	80 deg. DB	Low Side	62	65	68	70	73	76	78	81	84
	67 deg. WB	High Side	181	194	208	222	236	250	264	278	291
	85 deg. DB	Low Side	67	70	73	75	78	81	83	86	89
	72 deg. WB	High Side	187	201	216	230	244	258	272	287	301
A36AQ-A, A36AS-A A36AQ-B Rated CFM 1200	75 deg. DB	Low Side	64	66	68	71	73	75	78	80	82
	62 deg. WB	High Side	177	194	210	226	242	258	274	290	307
	80 deg. DB	Low Side	69	71	73	76	78	80	83	85	87
	67 deg. WB	High Side	183	200	216	232	248	264	280	296	313
	85 deg. DB	Low Side	73	76	79	81	84	87	89	92	95
	72 deg. WB	High Side	190	206	223	239	256	273	289	306	322
A42AQ-A, A42AS-A Rated CFM 1380	75 deg. DB	Low Side	63	66	69	71	74	77	79	82	85
	62 deg. WB	High Side	193	206	219	231	244	257	269	282	295
	80 deg. DB	Low Side	68	71	74	76	79	82	84	87	90
	67 deg. WB	High Side	198	211	224	237	250	263	276	289	302
	85 deg. DB	Low Side	73	76	79	82	85	88	91	94	97
	72 deg. WB	High Side	206	219	232	245	258	271	284	297	310
A48AQ-A, A48AS-A Rated CFM 1450	75 deg. DB	Low Side	69	71	73	76	78	80	83	85	87
	62 deg. WB	High Side	199	213	228	242	257	272	286	301	315
	80 deg. DB	Low Side	75	77	79	82	84	86	89	91	93
	67 deg. WB	High Side	204	219	234	249	264	279	294	309	324
	85 deg. DB	Low Side	81	83	85	88	90	92	95	97	99
	72 deg. WB	High Side	211	227	242	258	273	288	304	319	335
B368HQ1/ BC35B Rated CFM 1200	75 deg. DB	Low Side	58	61	64	66	69	72	74	77	80
	62 deg. WB	High Side	183	196	210	224	238	252	266	280	293
	80 deg. DB	Low Side	63	66	69	71	74	77	79	82	85
	67 deg. WB	High Side	187	201	216	230	244	258	272	287	301
	85 deg. DB	Low Side	68	71	74	77	80	83	86	89	92
	72 deg. WB	High Side	194	208	223	237	252	267	281	296	310
3HCQ1 Rated CFM 950	75 deg. DB	Low Side	55	58	61	63	66	69	71	74	77
	62 deg. WB	High Side	178	192	207	221	236	251	265	280	294
	80 deg. DB	Low Side	59	62	65	68	71	74	77	80	83
	67 deg. WB	High Side	182	197	212	227	242	257	272	287	302
	85 deg. DB	Low Side	64	67	70	73	76	79	82	85	88
	72 deg. WB	High Side	188	204	219	235	250	265	281	296	312
4HCQ Rated CFM 1300	75 deg. DB	Low Side	63	66	69	71	74	77	79	82	85
	62 deg. WB	High Side	194	206	218	230	242	254	266	278	290
	80 deg. DB	Low Side	68	71	74	76	79	82	84	87	90
	67 deg. WB	High Side	198	211	224	236	249	262	274	287	300
	85 deg. DB	Low Side	73	76	79	82	85	88	91	94	97
	72 deg. WB	High Side	206	219	232	244	257	270	282	295	308
BC36B Rated CFM 1200	75 deg. DB	Low Side	63	65	67	70	72	74	77	79	81
	62 deg. WB	High Side	175	189	204	218	233	248	262	277	291
	80 deg. DB	Low Side	68	70	72	75	77	79	82	84	86
	67 deg. WB	High Side	179	194	209	224	239	254	269	284	299
	85 deg. DB	Low Side	72	75	78	80	83	86	88	91	94
	72 deg. WB	High Side	185	201	216	232	247	262	278	293	309

Low side pressure \pm 2 PSIG (suction line @ outdoor unit quick connect)

High side pressure \pm 5 PSIG (liquid line @ outdoor unit quick connect)

Tables are based upon rated CFM (airflow) across the evaporator coil and should be found under section titled "Refrigerant Charge" elsewhere in manual. If there is any doubt as to correct operating charge being in the system, the charge should be removed, system evacuated, and recharged to serial plate instructions.

42UACQA
42UACSA
COOLING

TABLE 15

Air Temperature Entering Outdoor Coil Degree F

Model	Return Air Temperature	Pressure	°	°	°	°	°	°	°	°	°
			75	80	85	90	95	100	105	110	115
A42AQ-A, A42AS-A Rated CFM 1325	75 deg. DB	Low Side	63	65	67	70	72	74	77	79	81
	62 deg. WB	High Side	169	185	200	216	232	248	264	279	295
	80 deg. DB	Low Side	68	70	72	75	77	79	82	84	86
	67 deg. WB	High Side	173	190	206	222	238	254	270	286	303
	85 deg. DB	Low Side	72	75	78	80	83	86	88	91	94
	72 deg. WB	High Side	180	196	213	229	246	263	279	296	312
A48AQ-A, A48AS-A Rated CFM 1525	75 deg. DB	Low Side	67	69	71	74	76	78	81	83	85
	62 deg. WB	High Side	184	199	214	229	244	259	274	289	304
	80 deg. DB	Low Side	72	74	76	79	81	83	86	88	90
	67 deg. WB	High Side	188	204	219	235	250	265	281	296	312
	85 deg. DB	Low Side	78	80	82	85	87	89	91	94	96
	72 deg. WB	High Side	194	211	226	243	259	275	291	307	324
4HCQ Rated CFM 1200	75 deg. DB	Low Side	62	65	68	70	73	76	78	81	84
	62 deg. WB	High Side	187	204	220	234	252	268	284	300	317
	80 deg. DB	Low Side	67	70	73	75	78	81	83	86	89
	67 deg. WB	High Side	191	208	225	242	259	276	293	310	327
	85 deg. DB	Low Side	72	75	78	81	84	87	90	93	96
	72 deg. WB	High Side	197	215	233	250	268	286	303	321	339
5HCQ Rated CFM 1500	75 deg. DB	Low Side	68	70	72	74	76	78	80	82	84
	62 deg. WB	High Side	172	188	203	219	234	249	265	280	296
	80 deg. DB	Low Side	73	75	77	79	81	83	85	87	89
	67 deg. WB	High Side	177	193	208	224	240	256	272	287	303
	85 deg. DB	Low Side	79	81	83	85	87	89	91	93	95
	72 deg. WB	High Side	183	200	216	232	248	264	280	296	313
BC48A Rated CFM 1525	75 deg. DB	Low Side	66	68	70	73	75	77	80	82	84
	62 deg. WB	High Side	171	187	202	218	234	250	266	281	297
	80 deg. DB	Low Side	71	73	75	78	80	82	85	87	89
	67 deg. WB	High Side	175	192	208	224	240	256	272	288	305
	85 deg. DB	Low Side	77	79	81	84	86	88	91	93	95
	72 deg. WB	High Side	182	198	215	231	248	265	281	298	314
BC60A Rated CFM 1640	75 deg. DB	Low Side	70	72	74	76	78	80	82	84	86
	62 deg. WB	High Side	171	187	202	218	234	250	266	281	297
	80 deg. DB	Low Side	75	77	79	82	84	86	89	91	93
	67 deg. WB	High Side	175	192	208	224	240	256	272	288	305
	85 deg. DB	Low Side	81	83	85	88	90	92	95	97	99
	72 deg. WB	High Side	182	198	215	231	248	265	281	298	314
BC36B Rated CFM 1200	75 deg. DB	Low Side	62	64	66	68	70	72	73	75	76
	62 deg. WB	High Side	167	184	201	218	234	250	265	280	294
	80 deg. DB	Low Side	67	69	71	73	75	77	78	80	81
	67 deg. WB	High Side	171	189	206	223	240	240	256	272	302
	85 deg. DB	Low Side	71	74	77	79	81	83	84	86	87
	72 deg. WB	High Side	178	196	214	231	248	265	281	297	312

Low side pressure + 2 PSIG (suction line @ outdoor unit quick connect)

High side pressure + 5 PSIG (liquid line @ outdoor unit quick connect)

Tables are based upon rated CFM (airflow) across the evaporator coil and should be found under section titled "Refrigerant Charge" elsewhere in manual. If there is any doubt as to correct operating charge being in the system, the charge should be removed, system evacuated, and recharged to serial plate instructions.

TABLE 16

COOLING

Air Temperature Entering Outdoor Coil Degree F

Model	Return Air Temperature	Pressure	Air Temperature Entering Outdoor Coil Degree F								
			75	80	85	90	95	100	105	110	115
A42AQ-A, A42AS-A Rated CFM 1325	75 deg. DB	Low Side	60	63	66	68	71	74	76	79	82
	62 deg. WB	High Side	172	188	205	221	238	255	271	288	304
	80 deg. DB	Low Side	65	68	71	73	76	79	81	84	87
	67 deg. WB	High Side	176	193	210	227	244	261	278	295	312
	85 deg. DB	Low Side	70	73	76	79	82	85	88	91	94
	72 deg. WB	High Side	183	200	217	235	252	269	287	304	321
A48AQ-A, A48AS-A Rated CFM 1525	75 deg. DB	Low Side	67	69	71	73	75	77	79	81	83
	62 deg. WB	High Side	186	202	217	233	248	263	279	294	310
	80 deg. DB	Low Side	72	74	76	78	80	82	84	86	88
	67 deg. WB	High Side	190	207	223	239	255	271	287	303	320
	85 deg. DB	Low Side	77	79	81	84	86	88	91	93	95
	72 deg. WB	High Side	196	213	230	247	264	281	298	315	332
4HCQ Rated CFM 1300	75 deg. DB	Low Side	60	63	66	68	71	74	76	79	82
	62 deg. WB	High Side	193	210	227	244	261	278	295	312	329
	80 deg. DB	Low Side	65	68	71	73	76	79	81	84	87
	67 deg. WB	High Side	199	216	233	251	268	285	303	320	337
	85 deg. DB	Low Side	70	73	76	78	81	84	86	89	92
	72 deg. WB	High Side	205	223	241	259	277	295	313	331	349
5HCQ Rated CFM 1375	75 deg. DB	Low Side	64	66	68	70	72	74	76	78	80
	62 deg. WB	High Side	175	191	206	222	237	252	268	283	299
	80 deg. DB	Low Side	69	71	73	75	77	79	81	83	85
	67 deg. WB	High Side	180	196	211	227	243	259	275	290	306
	85 deg. DB	Low Side	74	76	78	81	83	85	88	90	92
	72 deg. WB	High Side	186	202	219	235	252	269	285	302	318
BC48A Rated CFM 1700	75 deg. DB	Low Side	64	66	68	71	73	75	78	80	82
	62 deg. WB	High Side	174	191	207	223	239	255	271	287	304
	80 deg. DB	Low Side	68	71	74	76	79	82	84	87	90
	67 deg. WB	High Side	180	196	213	229	246	263	279	296	312
	85 deg. DB	Low Side	73	76	79	82	85	88	91	94	97
	72 deg. WB	High Side	186	203	220	238	255	272	290	307	324
BC60A Rated CFM 1750	75 deg. DB	Low Side	68	70	72	75	77	79	82	84	86
	62 deg. WB	High Side	179	195	210	226	242	258	274	289	305
	80 deg. DB	Low Side	73	75	77	80	82	84	87	89	91
	67 deg. WB	High Side	185	201	216	232	248	264	280	295	311
	85 deg. DB	Low Side	79	81	83	86	88	90	93	95	97
	72 deg. WB	High Side	191	207	224	240	257	274	290	307	323

Low side pressure \pm 2 PSIG (suction line @ outdoor unit quick connect)
High side pressure \pm 5 PSIG (liquid line @ outdoor unit quick connect)

Tables are based upon rated CFM (airflow) across the evaporator coil and should be found under section titled "Refrigerant Charge" elsewhere in manual. If there is any doubt as to correct operating charge being in the system, the charge should be removed, system evacuated, and recharged to serial plate instructions.

60UACQA
60UACSA

TABLE 17

COOLING

Air Temperature Entering Outdoor Coil Degree F

Model	Return Air Temperature	Pressure	Air Temperature Entering Outdoor Coil Degree F								
			75 °	80 °	85 °	90 °	95 °	100 °	105 °	110 °	115 °
A48AQ-A, A48AS-A Rated CFM 1500	75 deg. DB	Low Side	61	62	64	65	67	69	70	72	73
	62 deg. WB	High Side	168	182	197	210	225	239	253	268	282
	80 deg. DB	Low Side	66	67	69	70	72	74	75	77	78
	67 deg. WB	High Side	173	187	202	216	231	246	260	275	289
	85 deg. DB	Low Side	71	72	74	75	77	79	80	82	83
	72 deg. WB	High Side	177	193	208	234	239	254	270	285	301
A60AQ-A, A60AS-A Rated CFM 1900	75 deg. DB	Low Side	64	66	68	71	73	75	78	80	82
	62 deg. WB	High Side	173	188	203	218	233	248	263	278	293
	80 deg. DB	Low Side	69	71	73	76	78	80	83	85	87
	67 deg. WB	High Side	177	193	208	224	239	254	270	285	301
	85 deg. DB	Low Side	73	76	79	81	84	87	89	92	95
	72 deg. WB	High Side	184	200	215	231	247	263	279	294	310
5HCQ Rated CFM 1600	75 deg. DB	Low Side	58	60	62	65	67	69	72	74	76
	62 deg. WB	High Side	179	195	210	226	242	258	274	289	305
	80 deg. DB	Low Side	61	64	67	69	72	75	77	80	83
	67 deg. WB	High Side	183	200	216	232	248	264	280	296	313
	85 deg. DB	Low Side	66	69	72	74	77	80	82	85	88
	72 deg. WB	High Side	189	206	223	240	257	274	291	308	325
BC48A Rated CFM 1625	75 deg. DB	Low Side	58	62	64	67	69	71	74	76	78
	62 deg. WB	High Side	184	200	217	233	250	267	283	300	316
	80 deg. DB	Low Side	65	67	69	72	74	76	79	81	83
	67 deg. WB	High Side	188	205	222	239	256	273	290	307	324
	85 deg. DB	Low Side	69	72	75	77	80	83	85	88	91
	72 deg. WB	High Side	194	212	230	247	265	283	300	318	336
BC60A Rated CFM 1800	75 deg. DB	Low Side	61	64	67	69	72	75	77	80	83
	62 deg. WB	High Side	185	201	216	232	247	262	278	293	309
	80 deg. DB	Low Side	66	69	72	74	77	80	82	85	88
	67 deg. WB	High Side	189	206	222	238	254	270	286	302	319
	85 deg. DB	Low Side	71	74	77	80	83	86	89	92	95
	72 deg. WB	High Side	195	212	229	246	263	280	297	314	331

Low side pressure \pm 2 PSIG (suction line @ outdoor unit quick connect)
High side pressure \pm 5 PSIG (liquid line @ outdoor unit quick connect)

Tables are based upon rated CFM (airflow) across the evaporator coil and should be found under section titled "Refrigerant Charge" elsewhere in manual. If there is any doubt as to correct operating charge being in the system, the charge should be removed, system evacuated, and recharged to serial plate instructions.