

**OIL FURNACE
INSTALLATION INSTRUCTIONS**

MODELS:

FH085D36B

FH110D48B

FL110D48B

**COPYRIGHT SEPTEMBER, 1989
BARD MANUFACTURING COMPANY
BRYAN, OHIO**

INDEX

INSTALLATION AND OPERATING INSTRUCTIONS	1
Location	1
Wiring	1
Oil Line Piping	1
Oil Burner	1
Burner Adjustment	2
Checks and Adjustments	2
Burner Nozzle	3
Ventilation	4
Venting	4
Thermostat	4
Fan and Limit Control	4
MAINTENANCE	5
Lubrication	5
Inspect Air Filter	5
Final Inspection and Test	5
Return Air	6
SERVICE HINTS	6
Common Causes of Trouble.	6
Care of Finish	7
Cleaning of Furnace	7

INDEX OF FIGURES AND TABLES

Figure 1	3
Table 1	1
Table 2	3
Table 3	5

INSTALLATION AND OPERATING INSTRUCTIONS FOR OIL FURNACES

LOCATION

When installing the furnace be sure to provide adequate space for easy service and maintenance. Locate the furnace as close to the chimney as practical, giving consideration to the accessibility of the oil burner, controls, and blower for service. Allow a minimum of 24 inches at front of furnace for servicing oil burner. Allow enough room at the rear of the furnace to change filters and remove the blower. Clearance from combustible material as stated on the furnace must be maintained. If close clearances are not stated, use the recommended standard clearance (see Table) or clearances permitted by local codes. For basement installation, a raised concrete pad is recommended. This will keep the bottom of the furnace dry and reduce rusting.

An oil burner must have a generous supply of combustion air to operate properly. The flow of combustion and ventilating air must not be obstructed from reaching the furnace.

The furnace area must be kept clear and free of combustible materials, gasoline and other flammable vapors and liquids.

TABLE 1

MINIMUM CLEARANCES--INCHES												
Minimum Installation Clearances									Minimum Service Clearances			
Model	Plenum					Plenum			Floor Δ			
	Top	Front	Vent	Back	Sides	Sides	Duct $\textcircled{1}$	Floor Δ	Front	Back	Sides	
FHO85D36B	2	6	9	1	2	2	2	C	24	--	--	
FH110D48B	2	6	9	1	2	2	2	C	24	--	--	
FL110D48B	2	8	9	6	2	2	2	NC	24	24	18*	

$\textcircled{1}$ For the first three feet from plenum.
 Δ C - combustible flooring NC - non-combustible floor
 * Maintained on one side or the other to achieve filter access.

WIRING

All units are fully factory wired. Multi-speed blowers are factory wired on high speed for cooling/manual fan operation. Heating speeds are wired for the largest input and may need lower speed for field installed low input nozzle.

All wiring must conform to the National Electrical Code and all local codes. A separate fuse or breaker should be used for the furnace. If replacement wire is necessary, use 105 degrees C, 16 gauge wires.

OIL LINE PIPING

First determine whether the pipe system is to be a single line system or a two line system. After determining the best piping system for the application, refer to the pump specifications on page 10. All connections must be absolutely air tight or you will have a malfunction of the burner. When installing the piping, a good oil filter should be installed close to the burner. A single line system is recommended for gravity feed.

OIL BURNER

All units are shipped with the oil burner installed. Inspect firepot refractory before firing to be sure it has not been jarred out of position in shipment. Burner air tube must not extend beyond inside surface of firepot, preferable location is 1/8 inch from inside surface.

CAUTION

Never attempt to use gasoline in your furnace. Gasoline is more combustible than fuel oil and could result in a serious explosion.

BURNER ADJUSTMENT

All oil burner installations should be performed by a qualified installer in accordance with regulations of the National Fire Protection Standard for Oil-Burning Equipment, NFPA No. 31, and in complete compliance with all local codes and authorities having jurisdiction. A qualified installer is an individual or agency who is responsible for the installation and adjustments of the heating equipment and who is properly licensed and experienced to install oil-burning equipment in accordance with all codes and ordinances.

The proper installation and adjustment of any oil-burner requires technical knowledge and the use of combustion test instruments.

CHECKS AND ADJUSTMENTS

1. Check all oil lines for leaks.
2. Check fuel pump pressure and adjust to 100 psig if necessary.
3. Drill 1/4 inch hole in flue pipe between flue outlet of furnace and barometric damper for draft measurement. Adjust barometric damper to obtain approximately .04 inches water column draft in flue pipe. Check draft overfire. For this measurement the burner observation port may be utilized. Draft overfire should be approximately .02 inches water column. It may be necessary to readjust barometric damper to obtain proper draft. Upon completion of draft readings, plug 1/4" hole in flue pipe with a sheet metal screw after making smoke check and taking stack temperature.
4. Air Adjustments. The air intake is located on the left side of the burner housing. The air shutters are factory set to the recommended start-up settings shown in the following chart. These settings are for initial start only and should be readjusted with the use of combustion analyzing equipment.

Adjust air supply by loosening lock screws and moving air shutter (2) and if necessary the bulk air band (3). Allow just sufficient air to obtain clean combustion determined by visual inspection. Reduce air supply until flame tips appear slightly smoky, then increase air just enough to make the flame tips appear absolutely clean.

5. Final Adjustments. At this point a final adjustment should be made using suitable instruments for smoke spot and CO₂ (or O₂) measurements. After allowing 10 minutes for warm up, air should be set so that the smoke number is zero or a trace; less than No. 1 smoke is highly desirable and should never exceed this limit. (Note: Occasionally a new heating appliance will require longer warm up time in order to burn clean because of the evaporation of oil deposits on the heat exchanger and other surfaces. CO₂ measured in the stack (ahead of the draft control) should be a minimum of 10% and a maximum of 13.0%.

Tighten all locking screws after final adjustments are made.

The unit should be started and stopped several times to make sure there are no significant rumbles or pulsations.

BURNER NOZZLE

Check nozzle size as to conformance to installation requirements. Install nozzle by screwing into hexagon adapter. Refer to recommended start-up settings.

Spacing of Electrodes. The electrodes should be spaced $5/32$ " apart. They should extend $1/16$ " beyond the end and $7/16$ " above the center of the nozzle tip as shown in the drawing below.

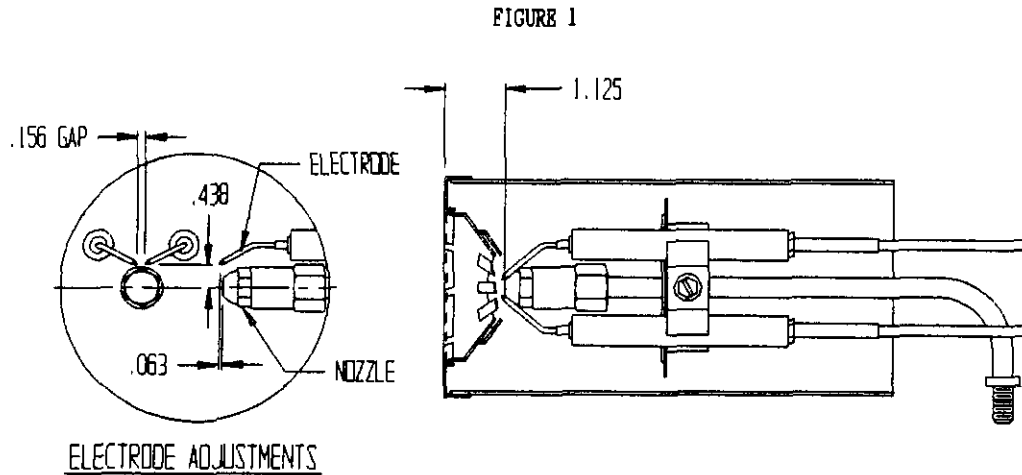

Gun Assembly Adjustment. The gun assembly can be adjusted in the slot inside of fan housing by loosening screw holding slot cover in position. Nozzle tip should ordinarily be located $1-1/8$ " behind the front face of the cone.

Removing Gun Assembly. Disconnect the oil line at the fan housing and remove lock nuts on copper tube fitting. Remove transformer hold down screw in upper left hand corner and loosen hold down clip in upper right hand corner, then swing transformer up and forward. Gun assembly can now be removed through this opening.

TABLE 2
RECOMMENDED START-UP SETTINGS

Furnace Model No.	Burner Model and Part Number	Factory Installed Nozzle	Field Installed Nozzle	Air Band Setting	Air Shutter Setting	Fan On/Off Setting	Blower Speed
FH085D36B	AF 9020-017	.75 80 A	°	-0-	5	110/90	Med.
			.65 80 A	-0-	3	110/90	Low
FH110D48B	AF 9020-017	1.00 80 A	°	-0-	7	110/70	Med. Low
			.85 80 A	-0-	6	110/70	Low
FL110D48B	AF 9020-018	1.00 80 A	°	-0-	8	135/110	Med. Low
			.85 80 A	-0-	6	135/110	Low

VENTILATION

An oil furnace must have a generous supply of fresh air available to support combustion. A furnace which is installed in a confined space must be provided with two permanent openings in the enclosure, one six inches from the top of the enclosure and one six inches from from the bottom. Each opening shall have a free area of not less than one square inch per 1,000 Btu input of the total input of all appliances within the enclosure. The openings shall be freely communicating with the interior areas having in turn adequate infiltration from the outside.

THE FLOW OF COMBUSTION AND VENTILATING AIR MUST NOT BE OBSTRUCTED FROM REACHING THE FURNACE.

VENTING

The flue pipe to the chimney must be the same size as the flue outlet of the furnace, have no reductions, be of a corrosion-resistant material, and have an upward pitch of 1/4" for every foot of horizontal run. A barometric damper of adequate size must be installed in the flue pipe observing the instructions packaged with the damper control. The barometric damper opening must be located in the same atmospheric pressure zone as the combustion air inlet to the furnace.

THERMOSTAT

These furnaces are designed to be controlled with any 24V heating or heating/cooling thermostat. The heat/cool thermostats must be designed for independent heat/cool transformer circuits to assure that the 24V transformer built into the oil primary control does not conflict with the air conditioner 24V transformer. The heat anticipator should be set at 0.40A. See additional information and wiring details on pages 8 and 9.

FAN AND LIMIT CONTROL

The fan and limit control is factory installed on all units. Set the fan control to come on at 130-135 degrees and off at 115 or 120 degrees. These settings may have to be varied due to the static pressure imposed upon the system.

When the installation is completed, measure the air temperature in the discharge plenum and return air plenum. The temperature rise across the unit should fall within the "Rise Range" as shown on the table below. It is normally desirable to operate in the middle of the range unless air conditioning or other installation requirements make that unfeasible. The speed of the blower may have to be either increased or decreased to obtain this temperature. The blower is equipped with a 4 speed motor to make these adjustments. See wiring details on pages 8 and 9.

The fan and limit control in the burner compartment governs the blower operation, by means of two temperature selections. One lever is set at 135 degrees for example, to start the blower, and the other lever is at a lower temperature, 110 degrees to stop the blower. These settings may be varied to suit the homeowner's comfort. A greater temperature difference between settings may result in less repetition of the blower operation at the end of the heating cycle. A low "off" temperature is recommended for longer blower operation as this keeps the air of the home in more constant circulation.

NOTE

Do not set the blower on setpoint lever of the combination fan/limit control above 150.

TABLE 3

MODEL	TEMPERATURE RISE RANGES AND LIMIT CONTROL SETTINGS °F			
	NOZZLE		RISE RANGES	LIMIT SETTING
	o			
FH085D36B	.65 80	A	50 - 80	170
	o			
	.75 80	A	60 - 90	170
	o			
FH110D48B	.85 80	A	50 - 80	170
	o			
	1.00 80	A	60 - 90	170
	o			
FL110D48B	.85 80	A	50 - 80	240
	o			
	1.00 80	A	60 - 90	240

MAINTENANCE

LUBRICATION

Blower motor and oil burner motor bearings should be lubricated before starting and at least twice each year using a few drops of a good grade of SAE-20 motor oil. Some blowers have no oil cups and need no oiling.

INSPECT AIR FILTER

Clean filters before each heating season begins. It is recommended that filters also be cleaned at least twice during the heating season.

Be sure the new filters are set securely in the filter rack so there can be no leakage around them. (See instructions on inside of blower compartment door).

FINAL INSPECTION AND TEST

Final inspection and test of an installation shall be made to determine that the work has been done in full accordance with regulations and according to the highest standards for safety, performance and appearance. Such an inspection and test should indicate the following as a minimum:

1. Determine that all parts of the oil storage and circulating system, including tank, piping and burner, are free from oil leaks. Be sure that no oil discharges from the nozzle when burner is not operating.
2. Be sure that the suction line and pump have been entirely vented of air so that the burner has instantaneous oil shutoff at the nozzle and so that the pump operates without an air noise.
3. Check the flame adjustment to determine that the flame is clear, quiet, free of odor and oil nozzle is of proper size for the furnace.
4. Test operation of burner by operating the thermostat. First, set the thermostat above room temperature. Burner should start. Second, set thermostat below room temperature. Burner will stop.

5. Check operation of burner primary control in accordance with manufacturers' instructions included with the control. Following is the method we recommend in checking the safety switch in this primary control.
 - A. Flame Failure--simulate by shutting off oil supply manual valve, while burner is on. After 15 seconds the safety switch locks out, ignition stops, motor stops and the oil valve closes. The safety switch locks out as in flame failure.
 - B. Ignition Failure--test by closing oil supply while burner is off. Run through starting procedure. The safety switch locks out as in flame failure.
 - C. Power Failure--turn off power supply while burner is on. When burner goes out, restore power and burner will restart.
 - D. If operation is not as described, check wiring and installation first. If trouble appears to be in the control circuit, replace the flame detector. If trouble still persists, replace the burner mounted relay.

RETURN AIR

The return air to the furnace must be conducted from a source outside the utility room, closet, or furnace room to prevent chimney down draft. Also remember air openings in casing front, return air grilles, and warm air registers must not be obstructed.

SERVICE HINTS

"Preventive maintenance" is the best way to avoid unnecessary expense, inconvenience, and retain operating efficiency of your furnace. It is advisable to have your heating system and burner inspected at periodic intervals by a qualified serviceman. If trouble develops, follow these simple checks before calling the serviceman.

1. Make sure there is oil in tank and valve is open.
2. Make sure thermostat is set above room temperature.
3. Make sure electrical supply to furnace is on and fuses are not blown or circuit breakers tripped.
4. Reset safety switch of burner primary control.
5. Press thermal protector button of burner motor.
6. If burner runs but there is no flame, the fuel pump may be airbound. Follow instructions for bleeding fuel pump.

COMMON CAUSES OF TROUBLE

CAUTION

To avoid accidents, always open main switch (OFF position) when servicing burner.

BURNER WILL NOT PRODUCE FLAME. Check oil level gauge to see that there is sufficient oil in tank or tanks. Check the burner mounted relay control. **DO NOT ADJUST THIS CONTROL.**

Check position of electrodes; incorrect position will cause slow or delayed ignition. Clean electrodes and nozzle. Check and clean strainer in pump. If oil line filter is used, check filter condition.

BURNER STARTS OR STOPS TOO OFTEN. Limit control may be set too low. Check heat anticipator setting on thermostat.

NOZZLE PRODUCES A STRINGY FLAME. Worn tangential grooves in nozzle. Replace nozzle.

BASEMENT TANK HUM. Occasionally with a two-pipe installation there may be a low return line hum. Eliminate hum by installing a special anti-hum valve in the return line near pump.

HEAVY FIRE OR PULSATING FLAME may occur after burner starts. It may be caused by a slight oil leak in the fuel pump and cannot be corrected except by replacing the pump. This happens only when the burner is started.

CHATTERING SOUND OR HIGH PITCH NOISE from motor can usually be traced to where a conduit or BX cable is fixed rigidly or attached to some part of the building. Relieving this strain may eliminate noise.

PUMP SQUEALS OR CHATTERS. This may be caused by air in pipes. Check all joints in the oil supply pipe for leaks. Check strainer in pump; if dirty, clean.

INSUFFICIENT HEAT. Check limit control setting. It may be that flame is not allowed to stay on long enough to generate sufficient heat in furnace to heat the house properly. If the proper size furnace has been selected according to house requirements and satisfactory heat is not obtained, recheck the heating plant for size and capacity in relation to house. Check for clogged filters.

CARE OF FINISH

Your unit is painted with baked enamel. Like a good piece of furniture, it has an excellent appearance and an occasional waxing and dusting will keep it attractive for years.

CLEANING OF FURNACE

All units have one or more clean out plugs for easy cleaning of the heat exchanger. They are accessible either from the front or back on some units and the sides on other units. The furnace should be checked periodically to see if it needs cleaning.

CONNECTION DIAGRAM DANGER: ELECTRICAL SHOCK HAZARD
DISCONNECT POWER BEFORE SERVICING.

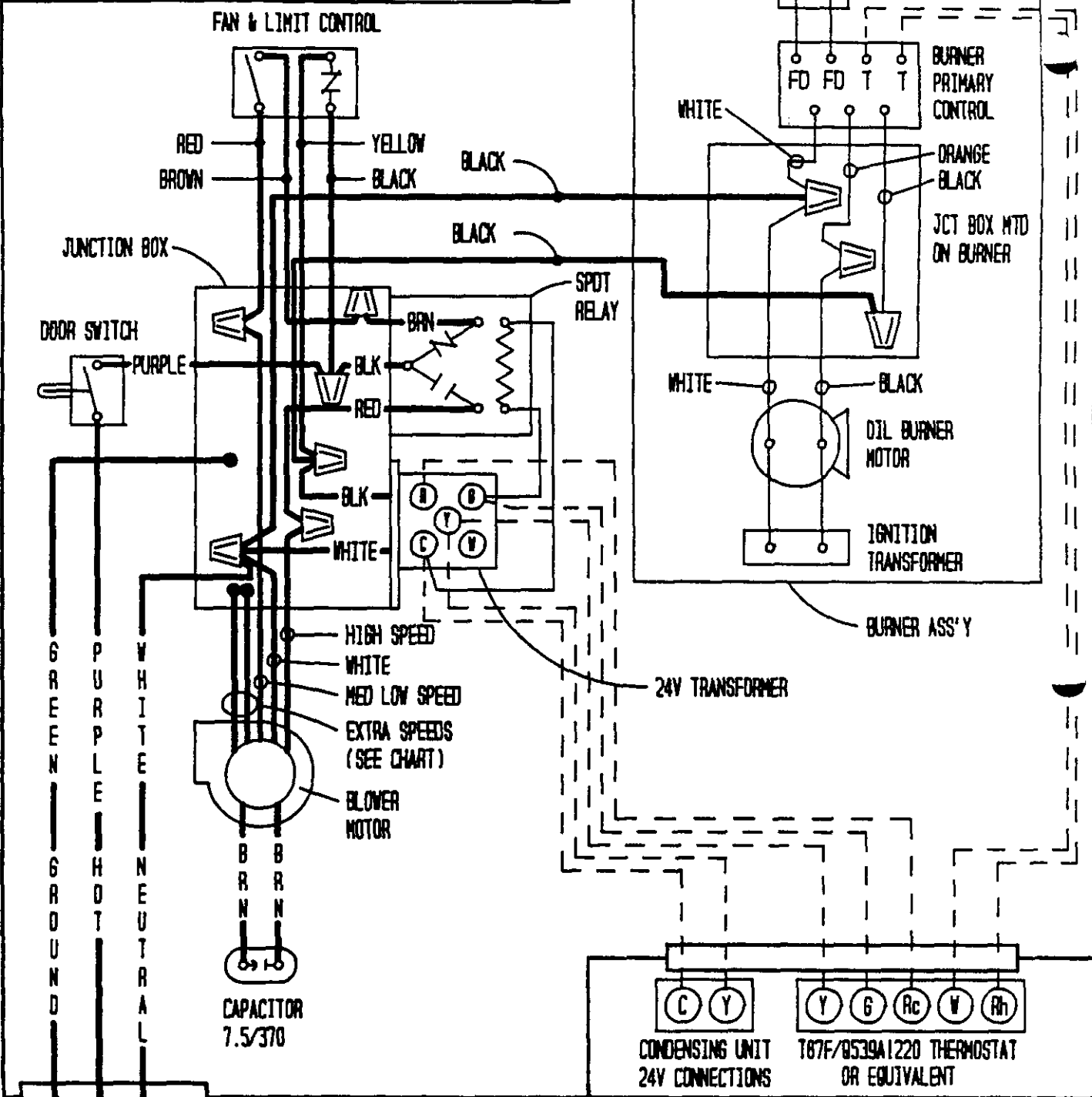

IF ANY OF THE ORIGINAL WIRE AS SUPPLIED WITH THE APPLIANCE MUST BE REPLACED, IT MUST BE REPLACED WITH WIRING MATERIAL HAVING A TEMPERATURE RATING OF AT LEAST 105 DEG C.

	FACTORY WIRING	FIELD WIRING
Low Voltage	---	---
High Voltage	---	---

MOTOR COLOR CODE	
COLOR	4 SPEED
WHITE	COMMON
BROWN	CAP
BLACK	HIGH
BLUE	MED HI
RED	MED LOW
ORANGE	LOW

4046-109

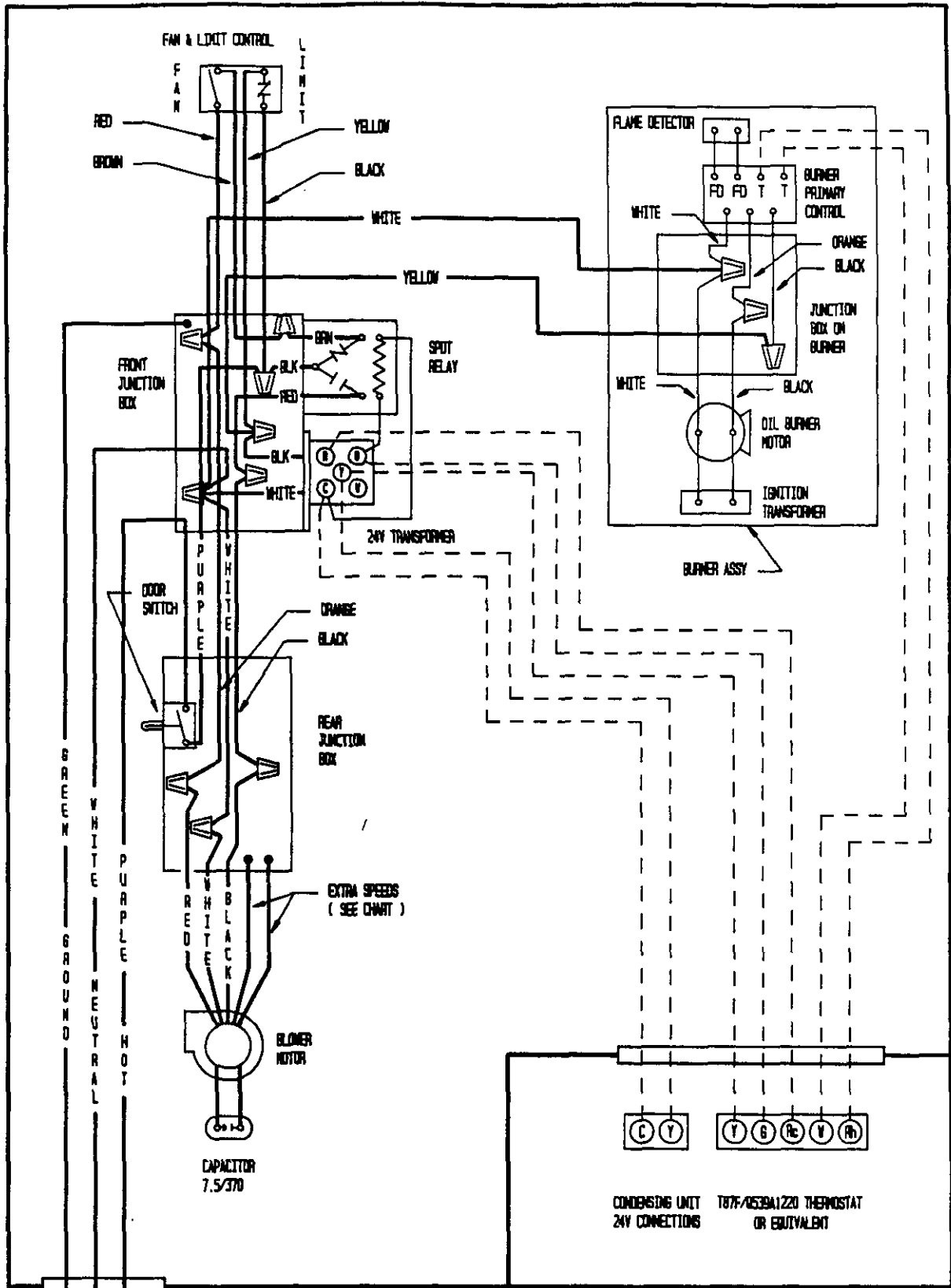

CONNECTION DIAGRAM

**WARNING: ELECTRICAL SHOCK HAZARD
DISCONNECT POWER BEFORE SERVICING**

IF ANY OF THE ORIGINAL WIRE AS SUPPLIED WITH THE APPLIANCE MUST BE REPLACED, IT MUST BE REPLACED WITH WIRING MATERIAL HAVING A TEMPERATURE RATING OF AT LEAST 105 DEG C.

	FACTORY WIRING	FIELD WIRING
Low Voltage	————	-----
High Voltage	————	-----

MOTOR COLOR CODE	
COLOR	4 SPEED
WHITE	COMMON
BROWN	CAP
BLACK	HIGH
BLUE	MED HIGH
RED	MED LOW
ORANGE	LOW

4047-110 0

A-7000 SINGLE STAGE AND B-8000 TWO STAGE FUEL UNITS

MODELS A2 & B2 FOR 3450 RPM, WHITE LABEL

MODEL B TWO STAGE FUEL UNIT HAS SAME PORTING ARRANGEMENT AS MODEL A

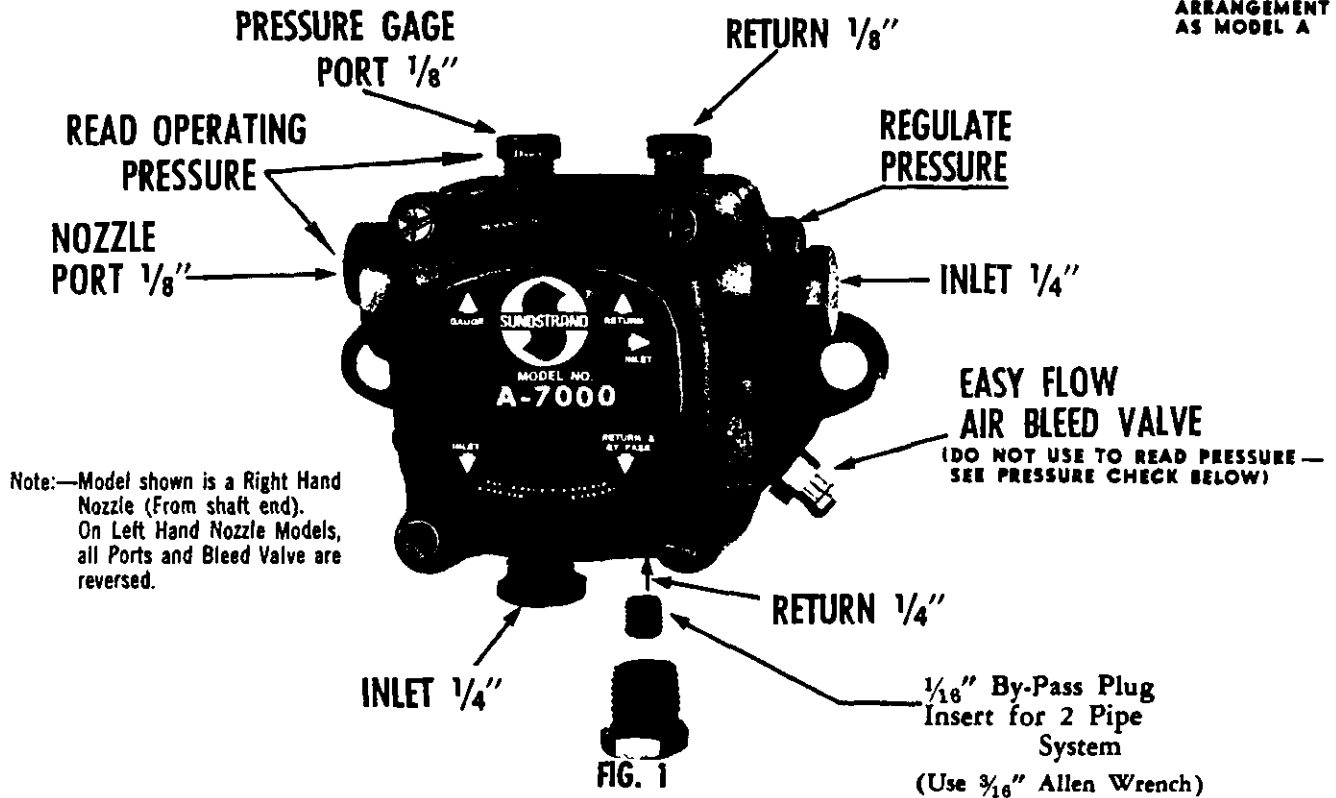

ONE-PIPE SYSTEM

Connect inlet line to pump inlet. Start burner. Arrange primary burner control for continuous operation during purging. Open easy flow bleed valve 1/2 turn CCW and start burner. Bleed unit until all air bubbles disappear—**HURRIED BLEEDING WILL IMPAIR EFFICIENT OPERATION OF UNIT.** Tighten easy flow bleed valve securely.

TWO-PIPE SYSTEM

Remove 1/16" plug from plastic bag attached to unit. Remove 1/4" plug from return port. Insert by pass plug (See Figure 1). Attach return and inlet lines.

Start burner—Air bleeding is automatic. Opening Easy Flow Air Bleed Valve will allow a faster bleed if desired.

Return line must run to within 3" of the bottom of the tank (See Figure 3). Failure to do this may introduce air into the system and could result in loss of prime.

CAUTION

Pressurized or gravity feed installations must not exceed 10 P.S.I. on inlet line or return line at the pump. A pressure greater than 10 P.S.I. may cause damage to the shaft seal.

PRESSURE CHECK

If a pressure check is made, use GAGE PORT OR NOZZLE PORT. DO NOT USE EASY FLOW BLEED VALVE PORT. The Easy Flow Bleed Valve Port contains pressure higher than operating pressure. Setting pump pressure with gage in the Easy Flow Bleed Valve Port results in WRONG operating pressure.

ALL SYSTEMS

IMPORTANT INFORMATION

Long or oversized inlet lines may require the pump to operate dry during initial bleeding period. In such cases, the priming may be assisted by injecting fuel oil into the pump gearset.

Under lift conditions, oil lines and fittings must be air tight. To assure this, "Pipe Dope" may be applied to both the used and unused inlet and both return fittings.

MOUNTING POSITION

Model "A" Single Stage Fuel Unit may be mounted in any position.

Model "B" Two Stage Fuel Unit may be mounted in any position except upside down (1/8" ports pointed down).

VACUUM CHECK

A Vacuum Gage may be installed in either of the 1/4" inlet ports or in the 1/8" return port (on single pipe installations), whichever is most convenient. The Model "A" pump should be used where the vacuum does not exceed 10" hg, vacuum and the Model "B" pump used where vacuum does not exceed 20" hg, vacuum.

ONE-PIPE SYSTEM (Model A)

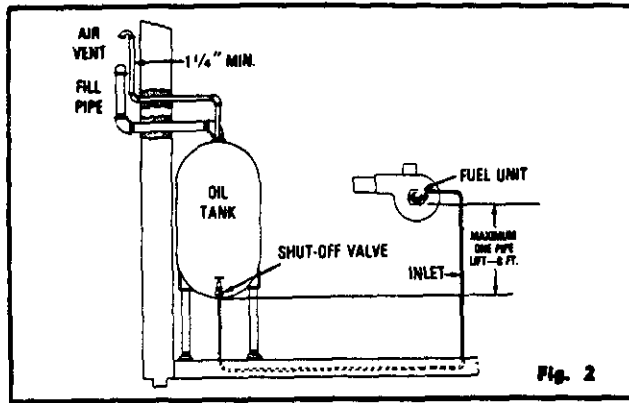

The SUNDSTRAND MODEL "A"-70 FUEL UNIT may be installed ONE-PIPE with Gravity Feed or Lift.

The maximum allowable lift is 8 ft.—See Figure 2.

IMPORTANT: One-pipe installations must be absolutely air tight or leaks or loss of prime may result. Bleed line and fuel unit completely. Bleed for 15 seconds after last air is seen from easy flow to be certain lines are air free.

TWO-PIPE SYSTEM (Model A and B)

A SINGLE STAGE

Lift "L" Fig 3	1725 RPM		3450 RPM	
	3/8" OD Tubing	1/2" OD Tubing	3/8" OD Tubing	1/2" OD Tubing
0'	65'	100'	53'	100'
1'	60'	100'	49'	100'
2'	54'	100'	45'	100'
3'	50'	100'	41'	100'
4'	45'	100'	37'	100'
5'	40'	100'	33'	100'
6'	35'	100'	29'	100'
7'	30'	100'	25'	99'
8'	25'	100'	21'	83'
9'	20'	83'	17'	68'
10'	16'	64'	13'	52'

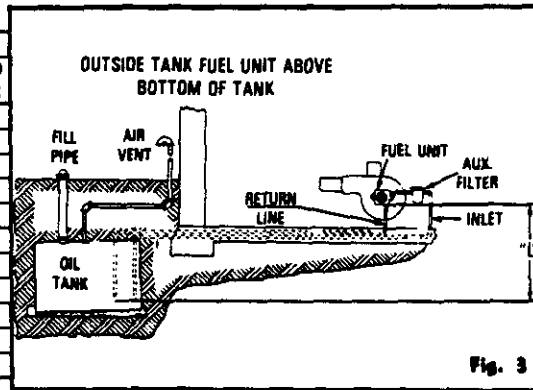

B TWO STAGE

Lift "L" Fig 3	1725 RPM		3450 RPM	
	3/8" OD Tubing	1/2" OD Tubing	3/8" OD Tubing	1/2" OD Tubing
0'	100'	100'	68'	100'
2'	92'	100'	63'	100'
4'	85'	100'	58'	100'
6'	78'	100'	53'	100'
8'	70'	100'	48'	100'
10'	63'	100'	42'	100'
12'	56'	100'	37'	100'
14'	48'	100'	32'	100'
16'	40'	100'	27'	100'
18'	33'	100'	22'	88'

ALWAYS TERMINATE RETURN LINE AS SHOWN IN FIG. 3
LINE LENGTHS INCLUDE BOTH VERTICAL & HORIZONTAL LENGTHS

Beckett

MICROPROCESSOR RECYCLE PRIMARY CONTROL MODEL TFA 850.2

The TFA 850.2 Control Provides Automatic, Recycling Control of an Interrupted Ignition Oil Burner.

- Self-check circuitry before start up.
- Integral transformer provides low voltage power for control circuit.
- Used with CD6 Cadmium Sulfide Cell.
- Microprocessor timer cuts off ignition after trial for ignition.
- 60 second nominal recycle timing.
- Available with 15 or 45 second safety timing.
- Enclosed safety switch is reset manually by the reset button.
- Mounts on standard 4 X 4 inch junction box!
- Exposed terminal strip with screw terminals for low voltage connection.
- Terminal strip for line voltage connections.

TFA 850.2 TECHNICAL SPECIFICATIONS

Supply Voltage:	120 volts 60 Hz
Power consumption:	max. 10 VA
Low-voltage protection at start:	No start below 86 volts
Max. current rating:	— MOTOR 10 amp. (locked rotor 60 amp.) — IGNITION 500 VA
Temperature range:	operation: 20° ... +125° FAHRENHEIT -5° ... +50° CELSIUS storage: -5° ... +140° FAHRENHEIT -20° ... +60° CELSIUS
Thermostat open voltage:	approx. 24 volt ac
Thermostat anticipator setting:	0.2 amp
Display:	6 functions: — red: safety lockout — red flashing: self-check failure — green: power on, normal function — green flashing: low supply voltage — amber: stray light or shorted cad cell — amber flashing: recycle mode — Start-up: approx. 20k OHMS — Run mode: approx. 4k OHMS
Flame amplifier sensitivity:	
Weight—	
control:	.67 LBS
base:	.28 LBS
Mounting studs:	any

INSTALLATION

CAUTION:

1. Installer must be a trained, experienced service technician.
2. Disconnect power supply before beginning installation.
3. Be sure combustion chamber is free of liquid or vaporized oil before attempting to start burner.
4. Perform a thorough checkout before leaving.

The TFA850.2 mounts on a standard 4 X 4 inch junction box. Locate the junction box in any convenient position on the burner, furnace, or nearby wall. Select a location where the ambient temperature will not exceed 125°F. When wiring is complete, secure the TFA850.2 to the junction box with 2 mounting screws.

Wiring

CAUTION

Disconnect power supply before making wiring connections to prevent electrical shock and equipment damage.

All wiring must comply with applicable codes and ordinances. Refer to information furnished by the system equipment manufacturer when wiring

SYSTEM — Connect the TFA850.2 to the system wiring at the terminals on base.

THERMOSTAT — Run wires from the low voltage thermostat directly to the low voltage terminal strip and connect to T-T terminals.

CADMIUM SULFIDE CELL — Run the No. 18 leads from the cad cell (usually installed by the burner manufacturer) to the low voltage terminal strip, connect to the F-F terminals.

OPERATION

Summary

On 24 volt thermostat call for heat, the TFA850.2 microprocessor goes through a self-check (approx. 1-4 seconds); the burner motor, oil valve, and ignition transformer are then energized. On line voltage call for heat, the TFA850.2 microprocessor goes through a self-check (approx. 10-15 seconds); the burner motor, oil valve, and ignition transformer are then energized. The TFA850.2 provides interrupted ignition by using a microprocessor to provide ignition during safety lockout timing period. If the cad cell fails to detect a flame within the specified period of time (15 or 45 seconds), the microprocessor locks out and must be reset for renewed burner operation.

If the flame should fail during normal operation, the burner immediately shuts down. After the control timer recycles (approximately 60 seconds), the burner will attempt to restart. If the cad cell then does not detect a flame within the specified period, the safety switch locks out and must be manually reset. The homeowner should not reset the control more than three (3) times.

Sequence of Operation

NORMAL OPERATION

EXTERNAL ACTION	PROTECTOR/RELAY ACTION
Close line switch.	Transformer primary is energized when line voltage is supplied to the control.
Thermostat calls for heat (move thermostat setting to top of scale, contacts close).	The microprocessor goes through a self check of its circuit (1-4 sec.), then energizes the burner motor, oil valve, and ignition relay contacts and starts safety time.
Cad cell senses flame.	At end of safety time, ignition is cut-off. The burner continues to operate as long as heat is called for.
Heat demand is satisfied. (Move thermostat setting to bottom of scale, contacts open).	Microprocessor turns off the burner motor and oil valve.

SAFETY OPERATION

Burner fails to ignite on call for heat.	Microprocessor goes through self check then starts burner motor, oil valve, and ignition. Also, initiates safety timing and locks out. Reset by pressing reset button.
Flame fails during on-cycle.	When the cad cell no longer senses flame, microprocessor is re-energized. After the microprocessor recycles (approximately 60 seconds), microprocessor goes through self check, then starts burner motor, oil valve and ignition. If flame is not established, goes to safety lock out. The safety switch must be manually reset. (If flame is re-established within the safety switch timing period, operation returns to normal.)
Power failure during call for heat.	System shuts down safety — all relays drop out, no power to the transformer or system (burner motor, oil valve, and ignition). System returns to normal operation when power is restored. Microprocessor requires 15 seconds to self-check before system can restart.

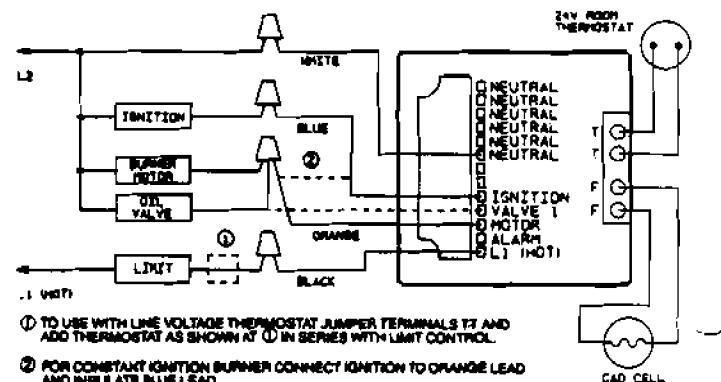

SERVICE AND CHECKOUT

Service

The TFA850.2 microprocessor controls are set at the factory and require no adjustment or periodic maintenance.

Checkout

Use the following procedure to check out the TFA850.2 control after installation.

1. Flame failure — shut off oil supply hand valve while burner is on. The burner should immediately shut down. After the ignition timer recycles (approximately 60 seconds), the burner will attempt to restart. After 15 or 45 seconds depending on model, microprocessor locks out, ignition stops, motor stops, and oil valve closes. Safety switch must be reset.

2. Ignition and/or fuel failure — shut off oil supply while burner is off. Run through starting procedure, do not turn oil valve on. Safety switch locks out as in flame failure.

3. Power failure — turn off power supply while burner is on. When burner goes out, restore power and burner will restart after 15 second self-check delay.

4. If operation is not as described, check wiring and installation first. If trouble persists, follow the complete procedure for checking out the TFA850.2 and cad cell printed on the cover insert.

CAUTION:

ONLY A TRAINED, EXPERIENCED SERVICE TECHNICIAN SHOULD ATTEMPT THE CHECKOUT PROCEDURE GIVEN ON THE INSERT.

NOTE: If you desire to trip the safety switch, run through the starting procedure below, omitting step 2. The switch will trip out on safety in 15 or 45 seconds, depending on model.



STARTING PROCEDURE

CAUTION:

Be sure combustion chamber is free of oil or vapor.

1. Push in and release red reset button.
2. Open hand valve in oil supply line.
3. Set thermostat to call for heat.
4. Close line switch.
5. Under normal conditions, burner operates until thermostat is satisfied.

TFA 850.2 SEQUENCE OF RESET

Reset Button:

- Pressing the reset button during *MBFEP (lockout safety time) causes a restart with approximately 1-4 seconds self-check delay.
- Pressing the reset button during the run mode causes a restart with approximately 1-4 seconds self-check delay
- Pressing the reset button during the recycle mode causes a restart with a full recycle delay.
- Pressing the reset button shortly after a safety lockout occurred causes a 1-4 seconds self-check delay, and then starts a 60-second scavenging delay.

Power Off

- Power off and on during the *MBFEP (lockout safety time) causes a restart with approximately 10-15 seconds self-check delay.
- Power off and on during recycle mode causes a new start of the recycle period.
- Power off and on during the run mode causes a restart with approximately 10-15 seconds self-check delay.
- Low voltage thermostat off and on during *MBFEP (lockout safety time), causes the control to go through the 60 second recycle mode delay. This prevents short cycling of the burner.
- Low voltage thermostat off and on during run mode causes a restart with approximately 1-4 seconds self-check delay.

*NOTE: "MBFEP" Main Burner Flame Establishment Period.

SEQUENCE FOR BLEEDING PUMP

- Pressing the reset button during the *MBFEP (lockout safety time) causes a restart with approximately 1-4 seconds self-check delay.

SEQUENCE OF SAFETY TFA 850.2

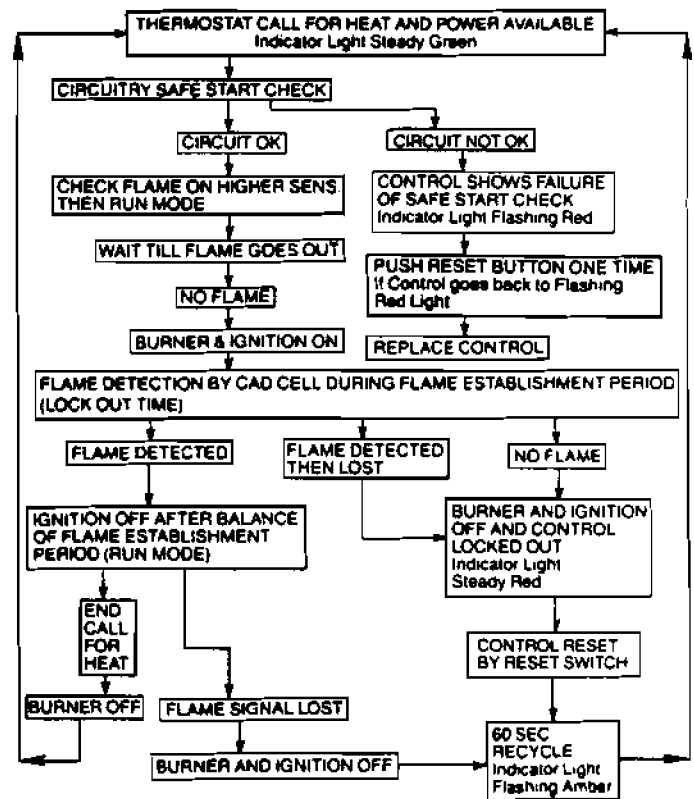

R.W. BECKETT CORPORATION

P.O. Box 1289 • Elyria, Ohio 44036