



INSTALLATION INSTRUCTIONS

UPFLOW CONDENSING GAS FURNACES

MODELS:

HI-BOY

CH060D36B

CH080D48B

CH100D60B

IMPORTANT NOTICE

THIS FURNACE IS NOT INTENDED FOR USE AS A CONSTRUCTION HEATER.

USE OF THIS FURNACE DURING CONSTRUCTION AND FINISHING PHASES OF A STRUCTURE IS CONSIDERED AS "OPERATION IN A CORROSIVE ATMOSPHERE" AND "UNUSUAL, NEGLIGENT OR IMPROPER USE" AND AS SUCH ARE CONSIDERED EXCLUSIONS BY THE BARD MANUFACTURING COMPANY LIMITED WARRANTY.

MANUAL 2100-166 REV. A
SUPERSEDES REV. --

TABLE OF CONTENTS

I.	Sizing of CH and CC Series 90+ Gas Furnaces	1
II.	Application	1A
	A. Standard Orifice Sizing	1
III.	Locating the Furnace.	2
IV.	Duct Work	3
V.	Combustion and Ventilation Air	3
VI.	Venting	5
	1. Vent Resizing Instructions	5
	2. Venting Troubleshooting Procedures.	5
	3. Vent Configurations	6
	4. General Instructions	6
	5. Types of Insulation	7
	6. Connecting Vent To Furnace	8
	A. Upflow Models--CH Series	8
	B. All Models--Vertical Venting	8
	7. Joining Pipe and Fittings	9
	A. PVC Cleaner--Primer and PVC Medium Body Solvent Cement.	9
	8. Horizontal Vents	9
	9. Vent Location	10
	10. Location Requirements	10
	11. Vent Termination	13
VII.	Combustion Air Intake	13
VIII.	Condensate Drain	14
IX.	Condensate Pump and Neutralizer	14
X.	Gas Supply and Piping	16
	A. General Recommendations	16
	B. Checking The Gas Piping	17
	C. Determining Gas Input--Natural Gas	17
	D. Determining Gas Input--LP Gas	18
	E. Gas Pressure Specifications	18
XI.	Wiring	18
	A. Electrical Power Supply	19
	B. Electrical Grounding	19
XII.	Thermostat	19
XIII.	Blower Operation	19
	A. Field Installed Equipment	20
XIV.	Filters	20
	A. Filter Locations--Removal and Replacement Procedures-- All Hi-Boy Furnaces	20
	B. Alternate Bottom Filter Location	21
	C. Five Ton Cooling Capacity	21
XV.	Sequence Of Operation	23
XVI.	Maintenance Instructions	23
XVII.	Service Agency Procedures	24
	A. Heat Exchangers and Flue Gas Passageways	25
XVIII.	Replacement Parts	25
XIX.	Wiring Diagram	26
XX.	S8600H Intermittent Pilot System Troubleshooting	27

FIGURES AND TABLES

Figure 1	4
Figure 1A	4
Figure 2	11
Figure 3	11
Figure 4	11
Figure 5	12
Figure 6	12
Figure 7	12
Figure 8	13
Figure 9	15
Figure 10	16
Figure 11	20
Figure 12	21
Figure 13	24
Figure 14	24

Table 1	2
Table 2	5
Table 3	6
Table 4	13
Table 5	17
Table 6	17
Table 7	18
Table 8	19
Table 9	20

SIZING OF CH AND CC SERIES 90+ GAS FURNACES

The sizing of high efficiency gas furnaces for both new and replacement installations is critical due to condensing design of the appliances. Oversizing of the furnace for any application can cause short cycling (short on-time) conditions, and this in turn permits condensate to occur in locations within the furnace where it was not intended to be.

It is a normal occurrence for some condensate to form in the upper areas of the primary heat exchanger and in the combustion air blower section of the furnace on start-up. As the furnace attains normal operating conditions, these areas dry up, and all condensing takes place in the secondary stainless steel heat exchanger.

Short-cycling of the furnace permits condensate to form in some areas and never dry up. This continuously wet condition can lead to corrosion and metal deterioration causing premature failure of those components.

The following guidelines must be used to properly size and select the furnace for all applications:

1. Always conduct an accurate heating load calculation using appropriate methods, typically Air Conditioning Contractors of America (ACCA) Manual J.
2. Always use the correct outdoor and indoor design temperatures for the area; the actual dimensional information for the structure; the correct insulation values for windows, doors, walls, and ceilings; make sure that the correct values are used for the tightness of the building; and all other characteristics are input correctly into the calculation. There is no need to inflate or adjust any of these values just to make sure the furnace will be large enough. There is adequate safety factor built into Manual J, and any deviation from real or actual values will cause a potentially gross oversizing.
3. Always make the furnace selection based upon the useful heat rating of the furnace expressed as heating capacity or output Btuh. Never use input capacity.
4. Never make a furnace selection based upon the size of the previous furnace. It was undoubtedly grossly oversized to begin with, and very probably energy efficiency improvements were done to the structure over time further reducing the Btu requirement.
5. The CH and CC-Series 90+ gas furnaces are available in three heating output capacities: 54,000 - 72,000 - 88,000 Btuh. A nominal 15 percent oversizing and 10 percent undersizing rule should be used in determining furnace to be installed. The following chart will assist in furnace selection:

Calculated Heat Loss Range (Btuh)	45,000----60,000	60,001----77,000	77,001----97,000
Use Furnace Output Rating (Btuh)	<----54,000---->	<----72,000---->	<----88,000---->

It is important to remember that furnace selections are made based upon the winter outdoor design conditions, and that very few hours of operation per year are at or near that temperature. And when the outdoor temperature is at the winter design condition, a correctly sized furnace will be operating the majority of the time with few and/or short off cycles.

Approximately 85 percent of the operating time of a typical furnace is when the building heat loss is only 10 - 80 percent of the winter design heat loss rating of the building, so it is essential not to oversize the furnace by either having an inflated calculated heat loss and/or picking one size larger furnace than calculated just to be sure.

APPLICATION

This is a fan-assisted Category IV forced air gas furnace for indoor installation in building constructed on site. The furnace installation must conform with local building codes and ordinances or, in their absence with the CAN1-B149 Installation Codes--latest edition, and the Canadian Electrical Code C22.1, Part 1--latest edition. It is the personal responsibility and obligation of the purchaser to contract a qualified installer to assure that installation is adequate and is in conformance with governing codes and ordinances.

***** IMPORTANT NOTICE *****

THIS FURNACE IS NOT INTENDED FOR USE AS A CONSTRUCTION HEATER.

USE OF THIS FURNACE DURING CONSTRUCTION AND FINISHING PHASES OF A STRUCTURE IS CONSIDERED AS "OPERATION IN A CORROSIVE ATMOSPHERE" AND "UNUSUAL, NEGLIGENT OR IMPROPER USE" AND AS SUCH ARE CONSIDERED EXCLUSIONS BY THE BARD MANUFACTURING COMPANY LIMITED WARRANTY.

When a furnace is used as a construction heater, it is operated under unusual and abnormal conditions that can cause condensation to occur in some portions of the CH furnaces that will not condense under normal operation conditions when properly sized, installed and set-up for operation.

Combined with condensation problems are the many sources of chloride that are present in high concentrations during construction phases of a structure. These chloride sources are either very reduced or the vapors have left once the construction activities are completed and the structure is ready to occupy.

Many of the more common construction sources of chlorides are listed below, and they are usually present in large quantities.

Cement/Concrete Mixtures	Tile/Counter Cements
Paint	Adhesives
Stain, Varnish	Cements and Glues
Solvents	Dust Particles
Wood Preservatives	Foam Insulations
Floor Sealers	

STANDARD ORIFICE SIZING

Rating of gas utilization equipment are based on sea level operation and need not be changed for operation at elevations up to 2,000 feet.

LOCATING THE FURNACE

When selecting a location for the furnace, observe the following rules.

1. The furnace should be set on a level floor. If the floor may become damp or wet at times, the furnace should be supported above the floor using a concrete base, bricks, patio blocks, etc., making sure adequate support is available for the furnace. Furnace approved for installation on combustible flooring shall not be installed directly on carpeting, tile or other combustible material other than wood flooring.
2. The furnace should be as centralized as practical with respect to the air distribution system.
3. The vent pipe should be as short as practical but must be at least 3 feet and no more than 60 feet in total equivalent length to vent combustion products outdoors, (see Venting).
4. Provide at least the minimum clearances specified in Table 1 for fire protection, proper operation and service access. These clearances must be permanently maintained. The ventilating air openings in the front of the furnace must never be obstructed.
5. Fresh air for combustion must be piped from the outside to the connection on either the right or left side of the furnace (see Combustion Air).
6. Minimum service clearances must take precedence over fire protection clearances (minimum installation clearances).
7. All models are approved for a utility room or closet installation.
8. A gas-fired furnace installed in a residential garage must be installed so that the burners and ignition source are located not less than 18 inches above the floor, and the furnace must be located or protected to avoid physical damage by vehicles.

CAUTION

DO NOT locate furnace where temperature may drop below freezing as condensate may freeze resulting in improper operation or furnace damage.

CAUTION

Do not store combustible materials near furnace or warm air ducts. The material may ignite by spontaneous combustion creating a fire hazard.

TABLE 1
MINIMUM CLEARANCES (INCHES)

Model	Minimum Installation Clearances						Min Service Clearances			
	Top	Front	Back	Right Side	Left Side	*Floor	Front	Back	Left Side	Right Side
CHO60	1	6	0	0	0	C	24	0	0	0
CHO80	1	6	0	0	0	C	24	0	0	0
CH100	1	6	0	0	0	C	24	0	0	0

*C--Floor may be combustible material. Refer to "Locating The Furnace" page 2, item 1.

DUCT WORK

Inadequate Supply Air and/or Return Air Duct Systems. Short cycling because of limit control operation can be created by incorrectly designed or installed supply and/or return air duct systems.

The duct systems must be designed using ASHRAE or ACCA design manuals and the equipment cfm and external static pressure ratings to insure proper air delivery capabilities.

On replacement installations, particularly if equipment is oversized, the duct systems can easily be undersized. Modifications may be required to assure that the equipment is operating within the approved temperature rise range when under full input conditions, and that no short cycling on limit controls is occurring.

CAUTION

When a furnace is installed so that supply ducts carry air circulated by the furnace to areas outside the space containing the furnace, the return air must also be handled by a duct(s) sealed to the furnace casing and terminating outside the space containing the furnace. This is to prevent drawing possible hazardous combustion products into the circulated air.

An 8 x 8 accessible opening must be in the first 12 inches of any side of the plenum. This access opening will be used to visually inspect the heat exchanger. The access cover must be attached in a manner to prevent leakage. See Figure 1 for example.

When the furnace is used in connection with a cooling unit*, the furnace shall be installed parallel with or on the upstream side of the cooling unit to avoid condensation in the heating element. With a parallel flow arrangement, the dampers or other means used to control flow of air shall be adequate to prevent chilled air from entering the furnace and, if manually operated, must be equipped with means to prevent operation of either unit, unless the damper is in the full heat or cool position.

*A cooling unit is an air conditioning coil, heat pump coil or chilled water coil.

COMBUSTION AND VENTILATION AIR

This furnace is intended to use outside air for combustion. Failure to connect the air intake to the outside may result in premature failure of the heat exchanger. Figures 2, 5, and 7 show a typical air intake connection. Connection of the air intake is a requirement for limited lifetime warranty of primary and secondary heat exchangers to be in effect. Refer to instructions on page 13 for combustion air intake. Consult local codes and ordinances for requirements applicable to your specific furnace installation conditions and comply with them. Provisions must be made for adequate combustion and ventilating air in accordance with the CAN1-B149 Installation Codes--latest edition, or applicable provisions of the local building codes.

The following types of installation will require OUTDOOR AIR for combustion, due to chemical exposures:

- o Commercial buildings
- o Buildings with indoor pools
- o Furnaces installed in laundry rooms
- o Furnaces installed in hobby or craft rooms
- o Furnaces installed near chemical storage areas

Exposure to the following substances in the combustion air supply will also require OUTDOOR AIR for combustion:

- o Permanent wave solutions
- o Chlorinated waxes and cleaners
- o Chlorine based swimming pool chemicals
- o Water softening chemicals
- o De-icing salts or chemicals
- o Carbon tetrachloride
- o Halogen type refrigerants
- o Cleaning solvents (such as perchloroethylene)
- o Printing inks, paint removers, varnishes, etc.
- o Hydrochloric acid
- o Cements and glues
- o Antistatic fabric softeners for clothes dryers
- o Masonry acid washing materials

Adequate provisions for ventilating air must be made. If the furnace is installed in a closet or utility room, ventilating air must be allowed to enter the room through two permanent openings of equal area. One opening shall be located within twelve (12) inches of the ceiling and one opening within twelve (12) inches of the floor. Each opening shall have a face area of one (1) square inch per 1000 BTU/HR, but not less than 100 square inches. See Figure 1A.

CAUTION
When a furnace is installed in a closet or utility room, never use this room as a return air plenum.

FIGURE 1

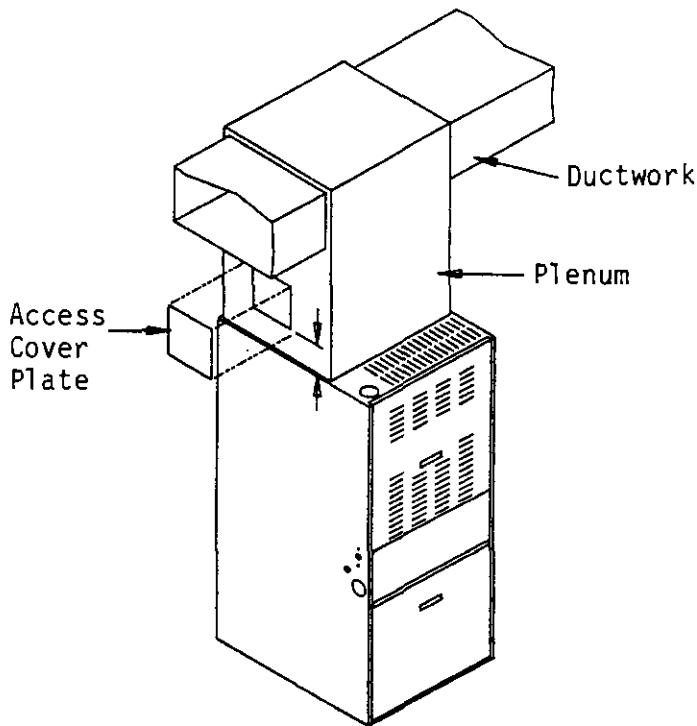
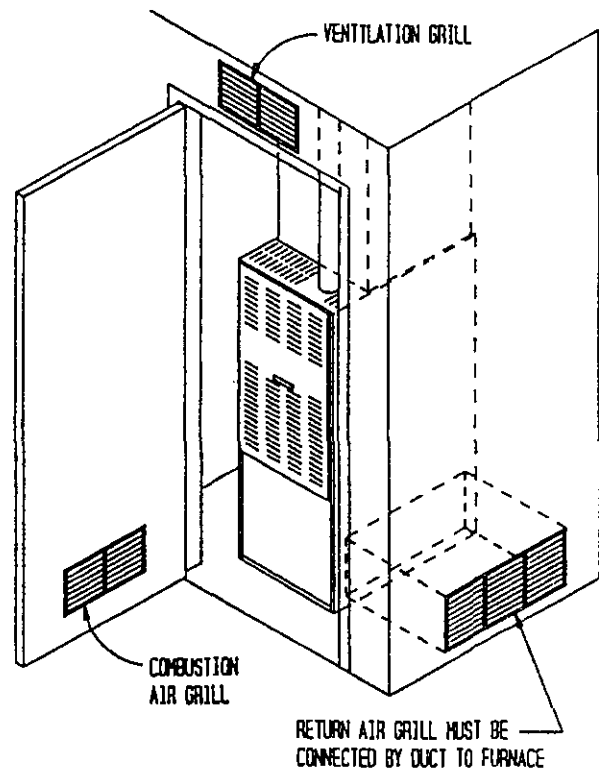

FIGURE 1A
FURNACE LOCATED IN CONFINED SPACE



VENTING

Vent Resizing Instructions

When an existing furnace is removed from a venting system serving other appliances, the venting system is likely to be too large to properly vent the remaining attached appliances.

The following steps shall be followed with each of the appliances remaining connected to the common venting system, placed in operation one at a time while the other appliances remaining connected to the common venting system are not in operation.

1. Seal any unused openings in the common venting system.
2. Visually inspect the venting system for proper size and horizontal pitch and determine there is no blockage or restriction, leakage, corrosion, and other deficiencies which could cause an unsafe condition.
3. Insofar as is practical, close all building doors and windows and all doors between the space in which the appliances remaining connected to the common venting system are located and other spaces of the building. Turn on clothes dryers and any appliance not connected to the common venting system. Turn on any exhaust fans, such as range hoods and bathroom exhausts, so they will operate at maximum speed. Do not operate a summer exhaust fan. Close fireplace dampers.
4. Follow the lighting instructions. Place the appliance being inspected in operation. Adjust thermostat so appliance will operate continuously.
5. Test for spillage at the draft hood relief opening after 5 minutes of main burner operation. Use the flame of a match or candle.
6. After it has been determined that each appliance remaining connected to the common venting system properly vents when tested as outlined above, return doors, windows, exhaust fans, fireplace dampers and any other gas-burning appliance to their previous conditions of use.
7. If improper venting is observed during any of the above tests, the common venting system must be corrected.

Venting Troubleshooting Procedures

TABLE 2

Symptoms	Possible Causes	How To Check And/Or Correct
Downdrafting through the furnace	Negative pressure within the structure caused by exhaust fan of device	Check for downdraft in vent where vent connects to unit with flame from a candle or a match.
	Location of vent terminal	Verify that vent termination is position with the recommended specifications stated in this manual.
	Incorrect or absent vent terminal	Verify that the vent terminal is designed for and is compatible with the venting system.
Condensation in venting system	Oversized venting system	Look for condensation in or around vent pipe joints or around flue connections at furnace. To correct this condition, design the venting system in accordance with the CAN1-B149 Installation Codes--latest edition.
	Uninsulated vent installed in an unconditioned space	Check for condensation in or around vent pipe joints. Also check around the flue connecting areas on the unit. Insulate the vent in unconditioned space to prevent the above condition.
	Running vent as a liner up an existing chimney without capping off the chimney	Check to make sure the space between the vent and the inside of the chimney has been sealed. With this space being open, it may allow too much cold air in and around the vent pipe allowing the flue products to condense causing condensation back at the unit.

Vent Configurations

1. Vent connectors serving Category I and Category II appliances shall not be connected into any portion of mechanical draft systems operating under positive pressure.
2. For Category II, III, and IV furnaces, the venting system shall be installed in accordance with the furnace manufacturer's installation instructions.

This furnace removes both sensible and latent heat from the combustion flue gases. Removal of latent heat results in condensation of flue gas water vapor. This condensed water vapor drains from the secondary heat exchanger into a 29-4C stainless steel drain pan. The condensate exits the drain pan by means of 3/8 I.D. vinyl hose. See Figure 9.

This furnace must be vented to the outdoors with either 2 inch round or 3 inch round PVC (poly-vinyl chloride) or CPVC (chlorinated poly-vinyl chloride) schedule 40 vent pipe unless local codes do not allow PVC or CPVC. See Table 3 for vent size selection. The following substitutes are permitted, only when approved by and installed in accordance with local codes. Polypropylene (PP), Polyethylene (PE), Polybutylene (PB) and Acrylonitrile-Butadiene-Styrene (ABS).

TABLE 3 PROPER VENT SIZE SELECTION

Furnace Models	Vent Length	Vent Diameter
CHO6OD36B	3 - 60 Ft.	2" PVC
CHO8OD48B	(1) 3 - 20 Ft.	2" PVC
	* 3 - 60 Ft.	3" PVC
CH10OD60B	3 - 60 Ft.	3" PVC

Vent length given is in equivalent foot measurements. Refer to Item 1, General Instructions.
 *If vent length is 20 to 60 equivalent feet, 3" must be run the entire length to the furnace.
 (1) For horizontal vents to west or north side of building, 3" PVC (for entire length from furnace to vent terminal) is recommended for equivalent lengths exceeding 10 feet to minimize possible nuisance actuation of pressure switch during high and/or erratic wind conditions.

IMPORTANT NOTE

For horizontal vent systems see special vent termination information on Page 11.

When substitute piping is used, it must be connected to the furnace at the no-hub connector located inside the furnace vestibule. See Figure 2. All joints, fittings, etc. must be cemented, sealed, or mechanically connected to prevent leakage of flue gases.

CAUTION

Each vent must serve only one furnace. Do not connect vent to existing vent or chimney.

General Instructions

1. The maximum vent length is 60 total equivalent feet with each 45 degree elbow counting as 2-1/2 feet and each 90 degree elbow counting as 5 feet. Do not count the elbow within the furnace cabinet in this measurement.

Example: 20 feet of straight vent pipe with 3 - 90 degree elbows equals 35 equivalent feet.

2. Minimum horizontal vent length is 3 feet and 1 elbow.

3. A maximum of 5 elbows permitted in the vent run.
4. Vent diameter must not be reduced.
5. All horizontal runs must slope upwards not less than 1/4 inch per foot from the furnace to the vent terminal.

NOTE: Elbows used to change from a vertical run to a horizontal run should be DWV type to provide the correct slope in the horizontal run. If other types of elbows are used, then 2 - 45 degree elbows should be used in place of one 90 degree, with elbows slightly misaligned to provide slope in the horizontal runs.

6. All horizontal vent pipe runs must be supported at least every 4 feet with metal pipe strapping. No sags or dips or low spots are permitted.
7. All vertical vent pipe runs must be supported every 4 feet where possible.
8. Do not install the vent pipe in the same chase with a vent from another gas or other fuel burning appliance. **EXCEPTION:** CPVC pipe may be run in the same chase as a B-1 vent pipe for a water heater as long as 2 inch clearance is maintained between the two piping systems.
9. For any sections of the vent piping system in free air, do not install the vent pipe within 6 inches of a single wall vent pipe (2 inch B-1 vent) from another gas or other fuel burning appliance.
10. The vent pipe can be run in the same chase or adjacent to supply or vent pipe for water supply or waste plumbing.
11. The vent pipe must be insulated if there is any chance of condensate freezing inside the pipe. This can occur if the vent pipe passes through an unconditioned space such as attic, crawl, uninsulated chase or a masonry chimney. It can also occur where the vent terminates above the roof or if an exterior vertical riser (Figure 3) is used to get above snow levels. Local climatic conditions and vent length must be considered. If vent height above roof exceeds 30 inches because of snow accumulation it must be insulated.

Vent System/Pressure Control System. On 90+ installations short cycling conditions by pressure switch operation can be created by vent system installations that have too much restriction (pressure drop) because of too many elbows, too much equivalent feet length, not the proper slope on horizontal runs, sag or low spots in horizontal piping sections creating condensation collection points, or incorrect vent terminal application or location.

Types Of Insulation

FOR INDOOR OR OUTDOOR USE

Armaflex closed cell foam or equal. Recommended thickness is one inch. Additional layers may be required for extreme cold climate conditions.

FOR INDOOR USE ONLY

Fiberglass insulation with vapor barrier, or equal. Recommended thickness of 1 inch up to 10 feet. 2 inch thickness if unconditioned exposure exceeds 10 feet.

Connecting Vent to Furnace

The furnace is shipped from the factory with a 2" PVC street ell installed in the furnace vestibule. This is the point where field connection is made.

UPFLOW MODELS--CH SERIES

1. Cut a piece of 2" PVC pipe 21" long and connect one end to the 2" street ell located inside the furnace vestibule.
2. Attach 2" no-hub connector just above the top panel of the furnace. See Figure 2 for upflow. This fitting will help support the weight of the vent system.
3. If 3" vent is required (see Table 3) it is at this point where the vent should be increased. Cut a 3" length of 2" PVC and insert one end into the open end of the no-hub connector. Install a 2" x 3" PVC reducer on the top of the 2" nipple. Run the 3" PVC from this point on to the point of termination. See Figure 4.

ALL MODELS--VERTICAL VENTING

A typical vent installation is shown in Figure 5.

- A. When vent penetrates through the roof and is brought above anticipated snow level, it is recommended that the pipe be cut off on a 45 degree angle. This will help prevent freezing and blockage of the vent system.
- B. Vent pipe running through an unconditioned space must be insulated. See "Types of Insulation" on page 7.
- C. An interior masonry chimney can be used as a chase as long as steps 8 and 9 under General Instructions on page 7 are followed.
- D. If an exterior masonry chimney is used as a raceway or chase, the vent piping must be insulated. See "Types of Insulation" on page 7. If a B-vent for a water heater is also run up through the same chimney, a minimum of one inch clearance from the insulation to the B-vent must be maintained at all points.
- E. For either an interior or exterior chimney, the top of the chimney must be sealed with a metal cap to prevent cold air from blowing into the chimney and surrounding the vent pipe(s).

Joining Pipe and Fittings

All pipe, fittings, solvent cement, primers and procedures must conform to American National Standard Institute and American Society for Testing and materials (ANSI/ASTM) standards.

Pipe and Fittings--ASTM D1785, D2466 & D2665 PVC Primer and Solvent Cement--ASTM D2564 Procedure for Cementing Joints Ref ASTM D2855.

WARNING

DANGER OF FIRE OR BODILY INJURY

PVC SOLVENT CEMENTS AND PRIMERS ARE HIGHLY FLAMMABLE. PROVIDE ADEQUATE VENTILATION AND DO NOT ASSEMBLE NEAR HEAT SOURCE OR OPEN FLAME. DO NOT SMOKE.

AVOID SKIN OR EYE CONTACT. OBSERVE ALL CAUTIONS AND WARNINGS PRINTED ON MATERIAL CONTAINERS.

All joints in the PVC vent must be properly sealed using the following material and procedure.

<p style="text-align: center;">CAUTION</p> <p style="text-align: center;">FOR PROPER INSTALLATION:</p> <p>DO NOT use solvent cement that has become curdled, lumpy or thickened.</p> <p>DO NOT thin. Observe shelf precautions printed on containers.</p> <p>For application below 32 degree F use only low temperature type solvent cement.</p>
--

PVC Cleaner-Primer And PVC Medium Body Solvent Cement

1. Cut pipe end square, remove ragged edges and burrs. Chamfer end of pipe, then clean fitting socket and pipe joint area of all dirt, grease or moisture.
2. After checking pipe and socket for proper fit, wipe socket and pipe with cleaner-primer. Apply a liberal coat of primer to inside surface of socket and outside of pipe. DO NOT ALLOW PRIMER TO DRY BEFORE APPLYING CEMENT.
3. Apply a thin coat of cement evenly in the socket. Quickly apply a heavy coat of cement to the pipe end and insert pipe into fitting with a slight twisting movement until it bottoms out.

NOTE: Cement must be fluid, if not, recoat.

4. Hold the pipe in the fitting for 30 seconds to prevent the tapered socket from pushing the pipe out of the fitting.
5. Wipe all excess cement from the joint with a rag. Allow 15 minutes before handling. Cure time varies according to fit, temperature and humidity.

NOTE: Stir the solvent cement frequently while using. Use a natural bristle brush or the dauber supplied with the can. The proper brush size is one inch.

Horizontal Vents

The furnace may be vented horizontally through an outside wall, using all of the applicable instructions under Vent Pipe Installation with these additional requirements. The requirements and limitations for Horizontal Venting are very strict. ALL HORIZONTAL VENT INSTALLATIONS MUST BE MADE IN ACCORDANCE WITH THESE INSTRUCTIONS.

Vent Location

The vent location must meet the requirements listed in the following instructions or applicable codes, whichever specifies the most clearance or strictest limitations.

CAUTION

THE COMBUSTION PRODUCTS AND MOISTURE IN THE FLUE GASES MAY CONDENSE AS THEY LEAVE THE TERMINAL ELBOW. THE CONDENSATE MAY FREEZE ON THE EXTERIOR WALL, UNDER THE EAVES AND ON SURROUNDING OBJECTS. SOME DISCOLORATION TO THE EXTERIOR OF THE BUILDING MAY OCCUR.

Location Requirements

The vent must be installed with the following minimum clearances and requirements.

1. 12 inches above ground level, above normal snow levels (when practical) and 6 inches out from the wall. See Figure 6.

NOTE: Ice or snow may cause the furnace to shut down if the vent becomes obstructed. If required use a vertical riser or shield vent to prevent blockage from drifting snow. See Figure 3.

2. Not above the walkway or area that may create a hazard or nuisance or be detrimental to the operation of other equipment.
3. 4 feet from and not above or below any door, window, gravity inlet or forced air inlet for the building.
4. At least 4 feet from any soffit or under eave vent.
5. Do not vent under any kind of patio or deck.
6. Locate vent on the side of the building away from prevailing winter winds when practical but taking into consideration other limitations to determine the best overall location. If installed on a side with prevailing winds, consider the possible effects of moisture damage from freezing on walls or overhangs (under eaves) and use protective measures such as shielding and/or sealing cracks, seams and joints but extend area of sealing to minimum of 6 feet. On masonry surfaces, use a rust resistant shield (18" square) behind vent. If a vertical rise is used, the shield must extend 9" above and 9" below as shown in Figure 6. Shield can be wood, plastic, sheet metal, etc.

FIGURE 2

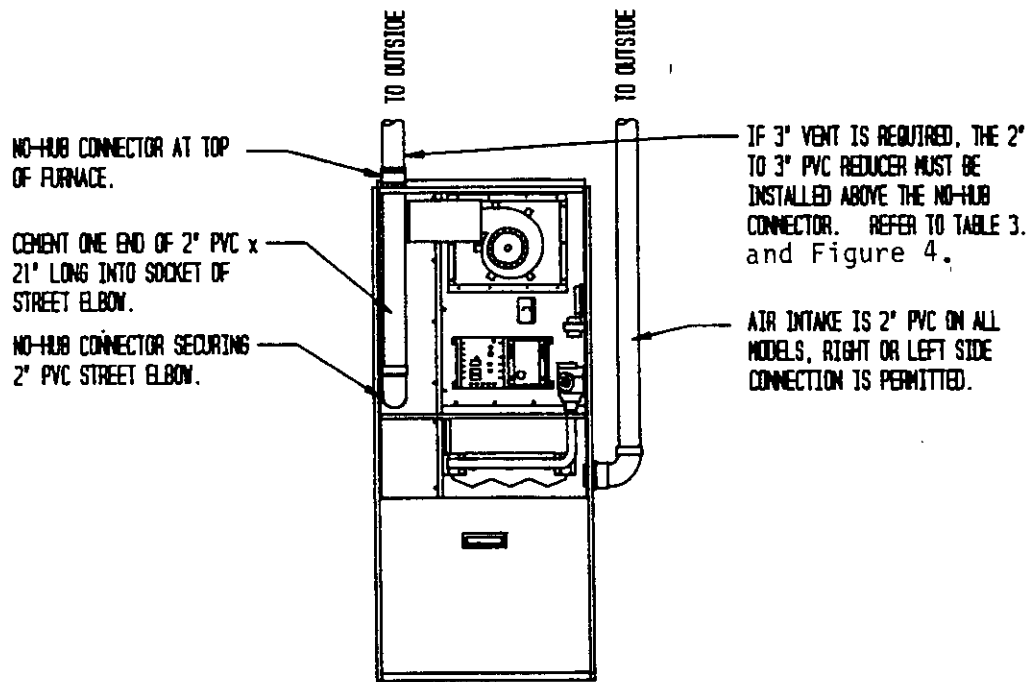

FIGURE 3

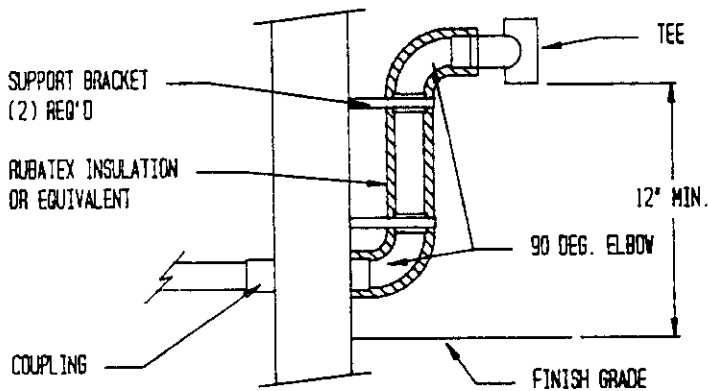

FIGURE 4

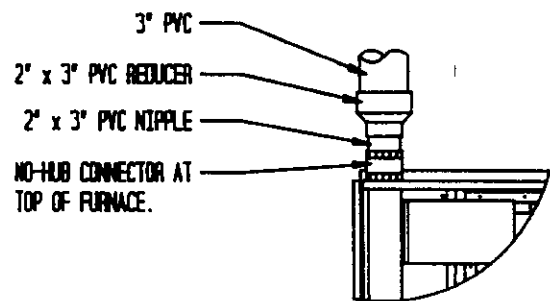
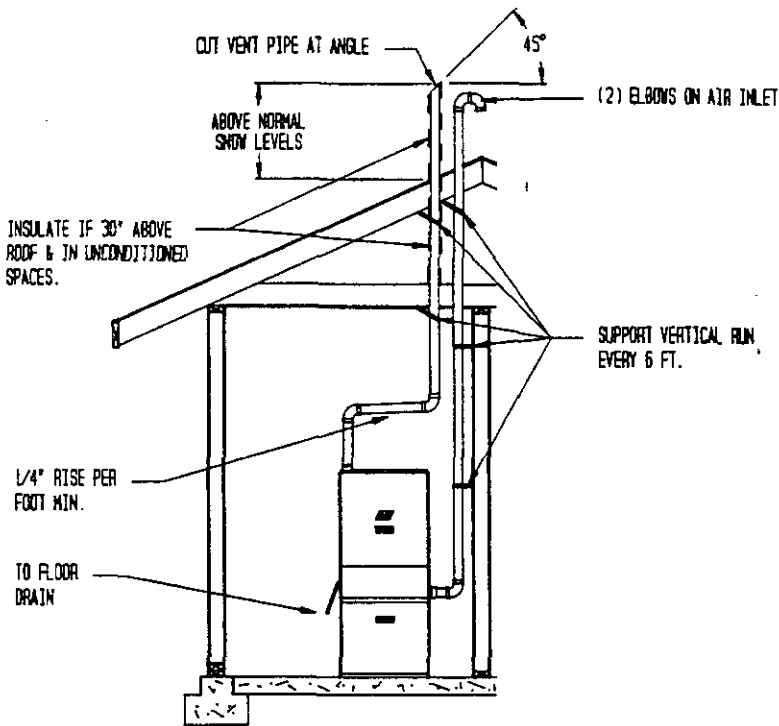

FIGURE 5



CAUTION

As a natural part of the unit's operation, normal products of combustion, including water vapor are vented to the atmosphere. Since the outside air temperature can be well below 32 degree F., it is possible that the water vapor in the exhaust will freeze, causing an ice buildup around the discharge opening of the pipe. During periods of extremely cold weather and prolonged operation of the furnace, this ice build-up could become quite large. The manufacturer does not recommend the installation of these units in locations above frequent vehicular and/or pedestrian traffic. The ice build-up could present a potentially hazardous situation if it becomes dislodged. The manufacturer will NOT be held responsible for any injury or property damage resulting from any improper installation.

FIGURE 6

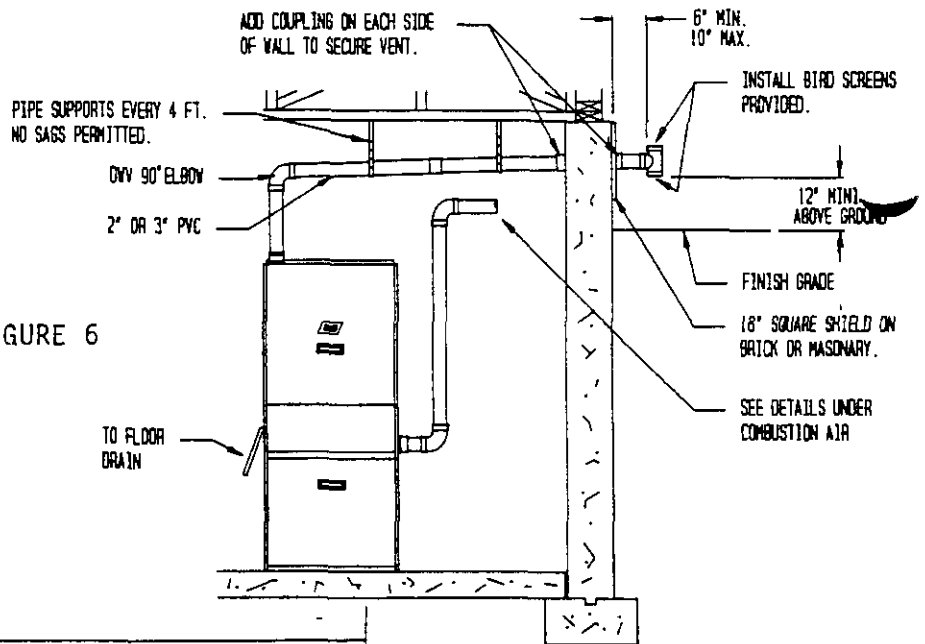
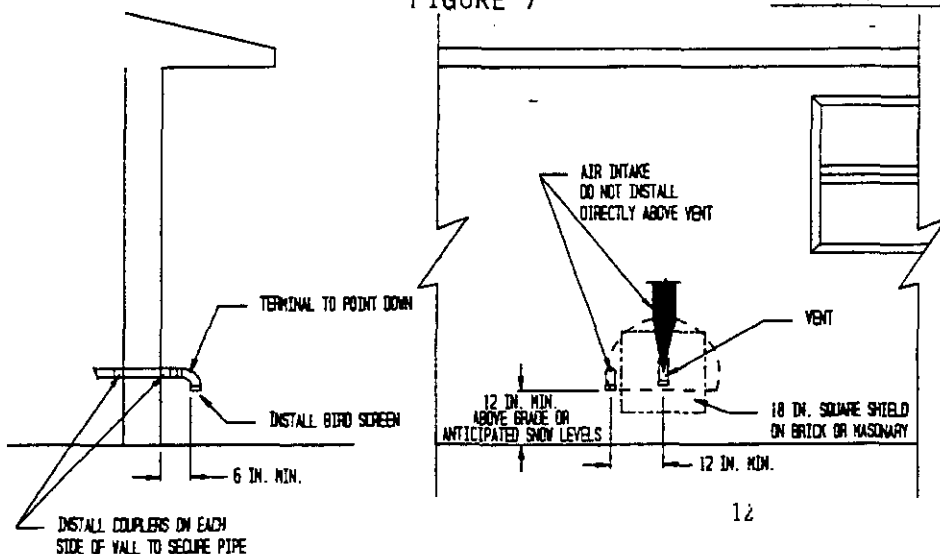

FIGURE 7



7. Do not locate too close to shrubbery as condensate may stunt or kill them.
8. Caulk all cracks, seams, and joints within 3 feet of vent.

A typical horizontal vent installation is shown in Figure 6.

Vent Termination

The vent termination will consist of either a 2" or 3" PVC tee, dependent upon vent size. See Table 4 below. The tee is to be a minimum of 6" and a maximum of 10" out from the wall and 12" above finish grade. See Figure 6. Bird screens are provided and are to be installed in both the top and the bottom of the tee. The tee should be installed in vertical position.

To exit the structure, a round hole is to be cut large enough to accommodate the pipe, yet smaller than the coupling so that a coupling installed on each side of the wall will prevent the vent pipe from being pulled out or pushed in the wall. See Figure 6.

TABLE 4 VENT TERMINAL SIZING CHART

Model	Vent Length*	Vent Diameter	Vent Terminal
CH060D36B	3-60	2" PVC	2" PVC Tee
CH080D48B	3-10	2" PVC	2" PVC Tee
	(1) 3-20	2" PVC	(2) 3" PVC Tee
	(3) 3-60	3" PVC	3" PVC Tee
CH100D60B	3-60	3" PVC	3" PVC Tee

*Equivalent feet.

- (1) For horizontal vents to west or north side of building, 3" PVC (for entire length from furnace to vent terminal) is recommended for equivalent lengths exceeding 10 ft. to minimize possible nuisance actuation of pressure switch during high and/or erratic wind conditions.
- (2) 2" x 3" reducer is used on tee side (outside) of wall, see Figure 8.
- (3) If vent length is 20 to 60 equivalent feet, 3" pipe must be run the entire length to the furnace.

FIGURE 8

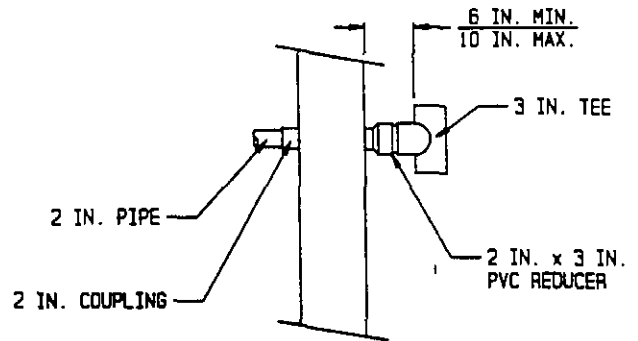

COMBUSTION AIR INTAKE

This furnace is intended to use outside air for combustion. Failure to connect the air intake to the outside may result in premature failure of the heat exchanger. Figures 2 and 5 show a typical air intake connection. Connection of the air intake is a requirement for limited lifetime warranty of primary and secondary heat exchangers to be in effect.

When installing the air intake, these guidelines must be followed.

1. The air intake may be connected to either the left side or right side of the furnace cabinet using the adapter and locknut shipped with the unit. The unused opening in the cabinet is to be plugged with the large hole plug supplied.
2. The air intake pipe is 2" PVC. The minimum horizontal length of the air intake is 3 equivalent feet and one elbow, the maximum length is 60 equivalent feet, with each 45 degree elbow counting as 2-1/2 feet and each 90 degree elbow counting as 5 feet (refer to Venting, General Instructions for example). Do not count the 90 degree elbow at the furnace side in this measurement.

3. The air intake terminal must be at least 12 inches away from the vent terminal, 6 inches out from the wall, and not directly above the vent terminal. See Figure 7.
4. Air intake terminal must be 12" above ground or above anticipated snow levels.
5. The bird screen supplied is to be installed into the end of the 90 degree elbow (see Figure 7).
6. Follow rules under venting for joining pipe and fittings.
7. On vertical intake, two 90 degree elbows must be used at the terminal to prevent moisture from entering the air intake (see Figure 5).
8. On horizontal air intakes one 90 degree elbow must be used on the termination. This elbow must point down to prevent moisture from entering the air intake (see Figure 7).
9. Attach couplings on each side of the wall to prevent pipe from being pushed in or pulled out.
10. Do not take the combustion air from the crawl space or attic space.

CONDENSATE DRAIN

The drain tubing that is provided with this unit is for the purpose of removing condensation from the furnace. A condensate trap is required for operation and is easily obtained when installed as shown in Figure 9. The drain line should slope "downhill" to the drain after exiting the furnace cabinet. Excessive condensate trap (long uphill and/or level runs) can cause the furnace to malfunction.

UPFLOW MODELS

The drain tubing supplied with the up-flow versions measures 3/8" I.D. x 1/2" O.D. x 60" long and is a clear PVC flex tubing. See Figure 9 for left or right side drain options.

CAUTION

Do not run drain to an area where temperature may drop below freezing point (32 degree F). Freezing of condensate could result in property damage or furnace malfunction.

CONDENSATE PUMP AND NEUTRALIZER

If no floor drain is available, a condensate pump or sump pump must be used for pumping condensate to the nearest drain. A condensate neutralizer cartridge may be required depending on the type of pump and/or local codes. If a condensate pump is used, or if local codes require, install a condensate neutralizer cartridge in the drain line as it exits the furnace.

Neutralizer part No. 8620-031 can be ordered separately as an option. It has a barbed fitting on both ends sized for 3/8" I.D. tubing. It can be installed either vertically or horizontally and should be located somewhere in drain line after it exits the furnace and ahead of condensate pump (if used) or drainage system.

NOTE: Vinyl drain tube measures 3/8" I.D. x 1/2" O.D. x 60" long for upflow units, and is clear in color. This tubing is to be used within the confines of the cabinet for the upflow models.

Silicone drain tube measures 3/8" I.D. x 5/8" O.D. x 36" long and is translucent in color. This tubing is to be used within the confines of the burner compartment (counterflow only).

FIGURE 9
UPFLOW MODELS

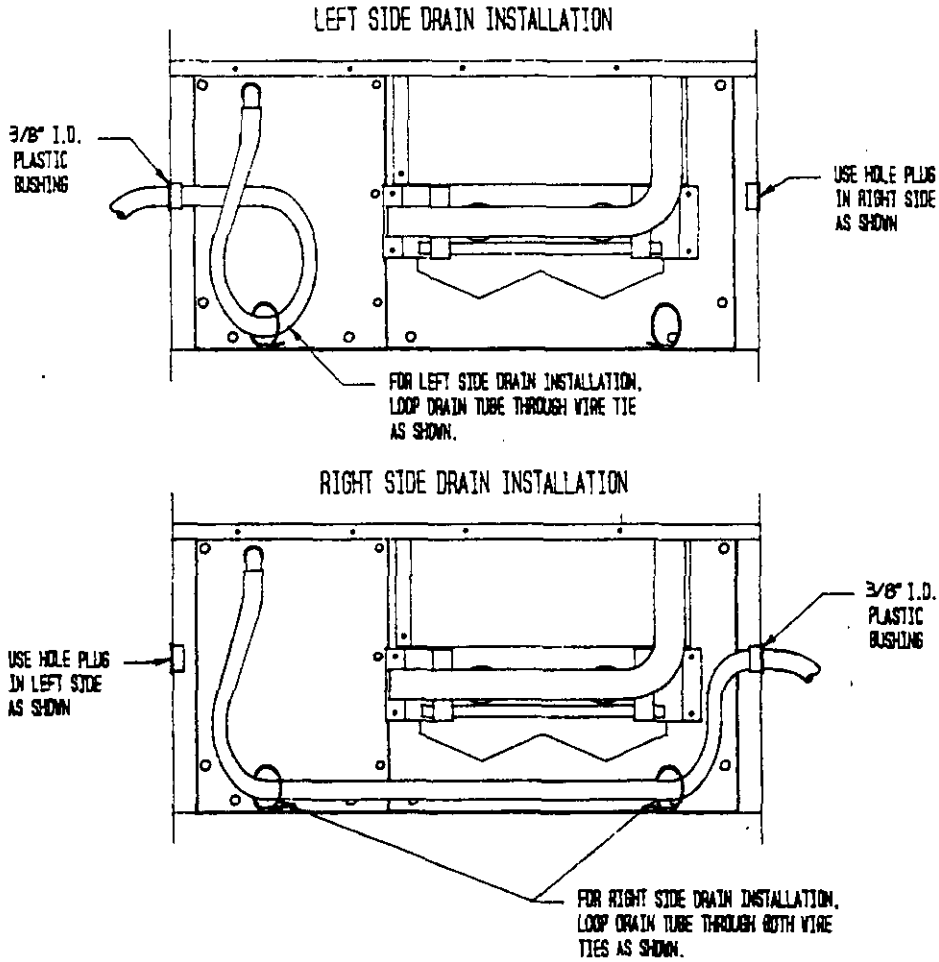

GENERAL NOTE

DO NOT DRAW DOWN WIRE TIES OR PULL TUBING TIGHT, TO PREVENT POSSIBLE KINKING OF TUBING.

GAS SUPPLY AND PIPING

General Recommendations

1. Be sure the gas line complies with the local codes and ordinances, or in their absence with CAN1-B149 Installation Codes--latest edition.
2. A sediment trap or drip leg must be installed in the supply line to the furnace.
3. A ground joint union shall be installed in the gas line adjacent to and upstream from the gas valve and downstream from the manual main shut-off valve.
4. A 1/8" N.P.T. plugged tapping accessible for test gauge connection shall be installed immediately upstream from the gas supply connection to the furnace for the purpose of determining the supply gas pressure.
5. A manual shut-off valve shall be installed in the supply gas line external to the furnace when required by local code. See Figure 10.
6. Use steel or wrought iron pipe and fittings.
7. DO NOT thread pipe too far. Valve distortion or malfunction may result from excess pipe within the control. Use pipe joint compound resistant to the action of liquified petroleum gases on male threads only. DO NOT use Teflon tape. See illustrations.
8. Refer to Tables 5 and 6 for Gas Pipe Sizes for Natural and L.P. gas. If more than one appliance is supplied from a single line size, capacity must equal or exceed the combined input to all appliances, and the branch lines feeding the individual appliances properly sized for each input.

FIGURE 10

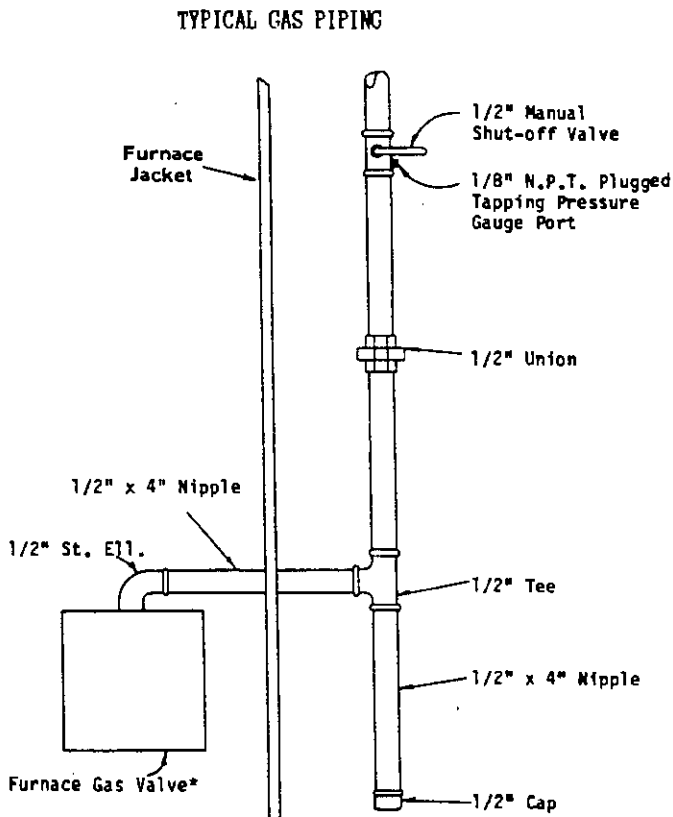

*Gas valve is covered to prevent dirt from entering. Remove cover only when ready to connect piping.

LENGTH OF STANDARD PIPE THREADS (Inches)

Pipe Size	Effective Length of Thread	Overall Length of Thread
3/8	3/8	9/16
1/2	1/2	3/4
3/4	1/2 - 9/16	13/16
1	9/16	1

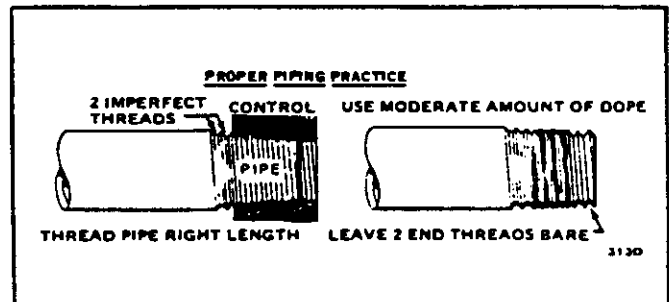

Checking The Gas Piping

Before turning gas under pressure into piping, all openings from which gas can escape should be closed. Immediately after turning on gas, the system should be checked for leaks. This can be done by watching the 1/2 cubic foot test dial and allowing 5 minutes to show any movement, and by soaping each pipe connection and watching for bubbles. If a leak is found, make the necessary repairs immediately and repeat the above test. The furnace must be isolated from the gas supply piping system by closing the manual shutoff valve on the combination gas control valve during pressure testing of the gas supply piping system at pressures up to 1/2 psig. The furnace must be disconnected from supply piping and supply piping capped during any pressure testing of supply piping system at test pressure in excess of 1/2 psig.

Defective pipes or fittings should be replaced and not repaired. Never use a flame or fire in any form to locate gas leaks, use a soap solution.

After the piping and meter have been checked completely, purge the system of air. DO NOT bleed the air inside the furnace. Be sure to relight all the gas pilots on other appliances that may have been extinguished because of interrupted gas supply.

TABLE 5
GAS PIPE SIZES/CAPACITY
NATURAL GAS

Length of Pipe--Ft.	Capacity-Btuh Per Hour Input		
	Pipe Size		
	1/2"	3/4"	1"
20'	92,000	190,000	350,000
40'	63,000	130,000	245,000
60'	50,000	105,000	195,000

TABLE 6
GAS TUBING AND PIPE SIZES
L.P. GAS

Length In Feet	Capacity--Btu Per Hour Input			
	Copper Tubing*		Iron Pipe	
	1/2"***	3/4"***	1/2"	3/4"
20'	62,000	216,000	189,000	393,000
40'	41,000	145,000	129,000	267,000
60'	35,000	121,000	103,000	217,000

*Copper tubing for gas supply must comply with limitation in CAN1-B149 Installation Codes-- latest edition.

**Outside diameter.

DETERMINING GAS INPUT--NATURAL GAS

The following is a procedure in which to measure gas input:

1. Turn off all gas appliances other than the furnace.
2. From local gas supplier, obtain the average heating value in BTU/CU FT of gas supplied to the installation site.
3. Light furnace following the lighting and operating instructions label.
4. With a stop watch, measure the amount of time, in seconds, it takes to consume two (2) cubic feet of gas.
5. Use the following formula to calculate the gas input of the furnace.

$$\text{Gas input rating in BTU/HR} = \frac{\text{BTU/CU FT} \times 7200}{\text{Time in seconds for two Cubic feet of gas flow}}$$

Example: Assume a time of 60 seconds for two cubic feet has been determined with a heating value of 1,000 BTU/CU FT.

$$\text{Gas input rating} = \frac{1000 \times 7200}{60}$$

$$\text{Gas input rating} = 120,000 \text{ BTU/HR}$$

6. If the input rate is not within two percent of the rated input, it may be achieved by adjusting the manifold pressure. If the specified input cannot be obtained, the furnace must be reorificed.

DETERMINING GAS INPUT--LP GAS

The pressure regulator on the storage tank must be adjusted to maintain a manifold pressure of 10.0" W.C. on the exit side of the furnace gas valve. This pressure will result in correct input when the burners are orificed properly.

GAS PRESSURE SPECIFICATIONS

This furnace is equipped with fixed orifices for rated input with the following gas pressures:

TABLE 7

	Supply		Manifold
	Minimum	Maximum	
Natural @ 1,000 BTU/CU FT	4.5" WC	11.0" WC	3.5" WC
LP @ 2,550 BTU/CF FT	11.0" WC	13.0" WC	10.0" WC

The supply pressure may be measured by attaching a water column gauge to a pressure tap adjacent to and up stream from the gas valve. The manifold pressure may be measured by removing the small pipe plug located in the top of the main burner manifold, and inserting a pressure tap. Attach water column gauge to tap and ignite main burner. Small variations in the gas pressure may be made, not to exceed ± 0.1 " W.C., to achieve rated manifold pressure. This may be achieved by turning the gas valve regulator adjusting screw clockwise to increase pressure or counter-clockwise to decrease pressure. Major changes in flow rate must be made by changing the size of the main burner orifices.

Underfire Conditions. Underfire conditions (not setting up furnace installation for full input operation) can also cause condensation and corrosion problems. Natural gas models are to be operated at 3.5 inches W.C. manifold pressure with standard factory supplied orifice sizes. Models converted to L.P. gas are to be operated at 10.0 inch W.C. using the designated orifices from the approved L.P. conversion kit.

It is not acceptable to either reduce manifold pressure or to reduce orifice size to compensate for oversized equipment. It is mandatory that manifold pressure be checked at time of installation/start-up of the furnace. Adjustments if necessary must be made to achieve correct manifold pressures as stated above and also on the rating plate on the furnace.

WIRING

CAUTION

For your personal safety, turn off electric power at service entrance panel before making any electrical connections.

All electrical work must conform with local codes and ordinances, or in their absence, with the Canadian Electric Code C22.1, Part 1--latest edition.

Electrical Power Supply

Run a separate 120 volt, AC circuit from a separate fuse or circuit breaker in the service entrance panel with an ampacity rating as shown in Table 8. Locate a shut off switch at the furnace. Make connections from this switch to the furnace junction box as shown in the furnace wiring diagram.

TABLE 8

Model	Volts/ HZ/PH	Total Amps	Blower Motor		Inducer Motor		Minimum Circuit Ampacity	Maximum Time Delay Fuse or HACR Circuit Breaker
			HP	FLA	HP	FLA		
CH060D36B	115/60/1	7.4	1/3	6.5	1/40	.90	15	15 amp
CH080D48B	115/60/1	11.4	1/2	10.5	1/40	.90	15	20 amp
CH100D60B	115/60/1	13.4	3/4	12.5	1/40	.90	17	25 amp

Electrical Grounding

RECOMMENDED GROUNDING METHOD

When installed, the furnace must be electrically grounded in accordance with local codes or in the absence of local codes, with the Canadian Electrical Code C22.1, Part 1--latest edition. Use a #14 AWG copper wire from green screw or green ground wire on the furnace to a grounded connection in the service panel or a properly driven and electrically grounded ground rod.

THERMOSTAT

Install the thermostat in accordance with instructions packed with it. Locate the thermostat 4-1/3 feet from the floor on an inside wall away from drafts, warm air registers and floor or table lamps. Refer to furnace wiring diagrams for connections.

All 24V wall thermostats have heat anticipators to compensate the thermostat for various system controls and allow the best possible cycle rates. Some anticipators are fixed and require no adjustment. However, the majority of wall thermostats have adjustable anticipators and do require adjustment to match the current rating of the thermostat circuit. Nominal rating of thermostat circuit is .60A, however, actual amp draw through the thermostat should be checked to determine heat anticipator setting.

Failure to adjust the anticipator lever to correspond to the actual current draw through the thermostat will cause severe short cycling if set too low and room temperature may never attain the thermostat set point, and if set too high, will cause room temperature to overshoot the set point.

BLOWER OPERATION

All models are three or four speed direct drive and are equipped with a heating-cooling blower relay. When matched with the appropriate wall thermostat, offers manual blower operation from the wall thermostat for air circulation.

CAUTION

After the furnace is operating with filters installed and all cabinet panels are in place, check the temperature rise through the unit to insure it is within the range specified on the furnace rating plate. If it is not, adjust blower speed until the temperature rise is within specified range.

Field Installed Equipment

Wiring to be done in the field between the furnace and devices not attached to the furnace, or between separate devices which are field installed and located, shall conform with the temperature limitation for Type T wire (63 degree F rise (36 degree C)) when installed in accordance with the manufacturer's instructions. Refer to wiring diagrams.

FILTERS

All models are shipped with filters. See Table 9 for sizes. Hi-Boy Models have the filters in their intended positions. Hi-Boy models are shipped with filter on the left side. They can alternately be located on right side or bottom. See following information.

TABLE 9
Filter Size for Gas furnace

Model	Size
CH060D36B	1 - 16x25x1
CH080D48B	1 - 16x25x1
*CH100D60B	1 - 16x25x1

*2-16x25x1 for 5 tons of cooling.

Filter Locations--Removal and Replacement Procedures--All Hi-Boy Furnaces

To remove filters from ALL sectional Hi-Boys, remove the lower blower compartment door by grasping the handle in the door and pull up and away from the furnace. Then, remove the "S" clip and spring by pulling the clip towards front of the furnace.

For right hand side filter location, relocate filter and retaining spring assembly to right side filter brackets.

FIGURE 11

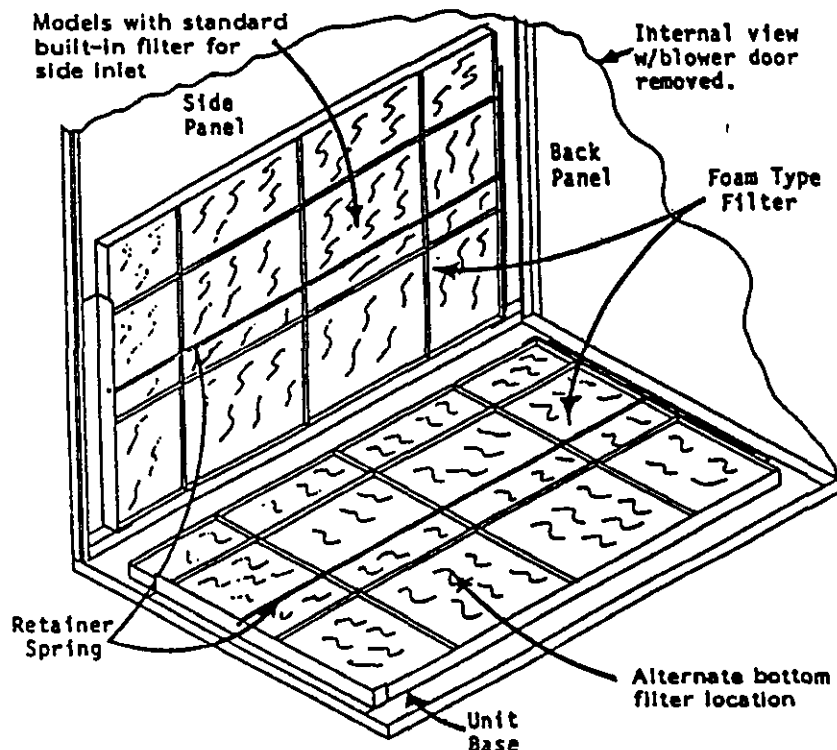

The filter may now be removed simply by pulling it towards the center of the furnace and outward.

The location may vary, depending on which side the installer located the return air duct.

This filter is the permanent high velocity type foam filter which may be washed and used over and over. DO NOT replace it with a fiberglass filter of the same size.

To replace filter, reverse the above process.

FIGURE 12

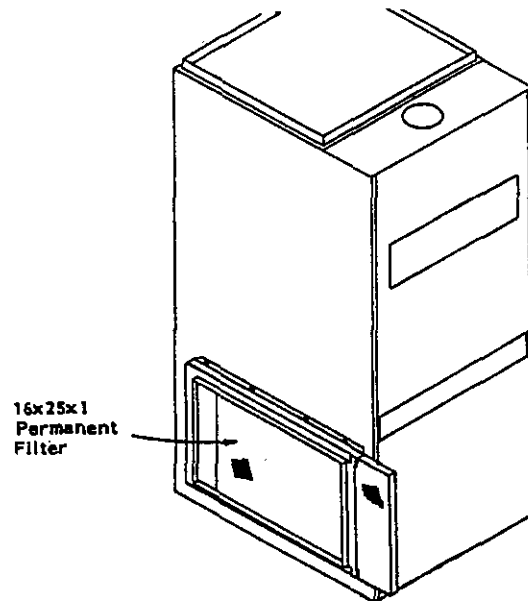

To remove filter from the optional external filter rack, grasp the exposed end of the filter and pull from the filter rack.

The location may vary, depending on which side the installer located the return air duct.

This filter is the permanent high velocity type foam filter which may be washed and used over and over. DO NOT replace it with a fiberglass filter of the same size.

To replace filter, reverse the above process.

Alternate Bottom Filter Location

All Hi-Boy models have a removable panel on the base for a bottom return air installation.

To utilize this feature, remove the fill plate by bending the four tabs up 90 degrees. Relocate filter retainer spring from side to bottom brackets. Leave the four tabs bent in the upright position as they will now serve to keep the filter positioned left to right.

Five Ton Cooling Capacity



If the model CH100D60B is used with 60,000 BTU cooling capacity, then 2 return air openings are required. This can be accomplished by using both sides of the furnace or one side and the bottom return. The furnace is shipped with one 16x25 permanent filter, one additional filter is required for this application.

FOR YOUR SAFETY READ BEFORE OPERATING

WARNING: If you do not follow these instructions exactly, a fire or explosion may result causing property damage, personal injury or loss of life.

- A. This appliance is equipped with an ignition device which automatically lights the pilot. Do not try to light the pilot by hand.
- B. BEFORE OPERATING smell all around the appliance area for gas. Be sure to smell next to the floor because some gas is heavier than air and will settle on the floor.
- WHAT TO DO IF YOU SMELL GAS**
- Do not try to light any appliance.
 - Do not touch any electric switch; do not use any phone in your building.
 - Immediately call your gas supplier from a neighbor's phone. Follow the gas supplier's instructions.
- C. Use only your hand to push in or turn the gas control knob. Never use tools. If the knob will not push in or turn by hand, don't try to repair it, call a qualified service technician. Force or attempted repair may result in a fire or explosion.
- D. Do not use this appliance if any part has been under water. Immediately call a qualified service technician to inspect the appliance and to replace any part of the control system and any gas control which has been under water.
- If you cannot reach your gas supplier, call the fire department.

OPERATING INSTRUCTIONS

1. STOP! Read the safety information above on this label.
2. Set the thermostat to lowest setting.
3. Turn off all electric power to the appliance.
4. This appliance is equipped with an ignition device which automatically lights the pilot. Do not try to light the pilot by hand.
5. Remove control access panel.
6. Push in gas control knob slightly and turn clockwise  to "OFF".
NOTE: Knob cannot be turned to "OFF" unless knob is pushed in slightly. Do not force.
7. Wait five (5) minutes to clear out any gas. If you then smell gas, STOP! Follow "B" in the safety information above on this label. If you don't smell gas, go to next step.
8. Turn gas control knob counterclockwise  to "ON".
9. Replace control access panel.
10. Turn on all electric power to the appliance.
11. Set thermostat to desired setting.
12. If the appliance will not operate, follow the instructions "To Turn Off Gas To Appliance" and call your service technician or gas supplier.

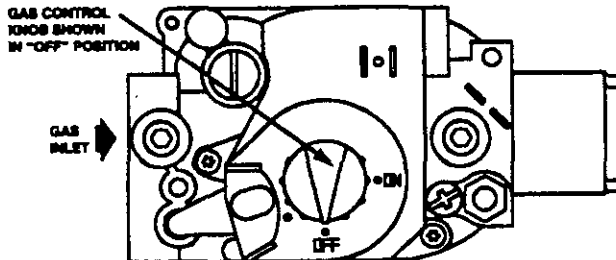

TO TURN OFF GAS TO APPLIANCE

1. Set the thermostat to lowest setting.
2. Turn off all electric power to the appliance if service is to be performed.
3. Remove control access panel.
4. Push in gas control knob slightly and turn clockwise  to "OFF". Do not force.
5. Replace control access panel.

7961-319

SEQUENCE OF OPERATION

On a call for heat from the thermostat, the induced draft blower relay is energized through the normally closed contacts of the air proving pressure switch. At this point the induced draft blower starts its operation. Once sufficient draft is established, the ignition module is energized through the normally open contacts of the air proving pressure switch. The pilot ignition electrode will begin to spark and the pilot valve will be energized allowing pilot gas to flow. Upon establishment of the pilot burner flame, adequate flame for burner ignition is proved to the control module allowing the main gas valve is to be energized and to discontinue ignition spark. At the same time the main valve is energized, a one minute blower delay timer is activated.

After this delay, the low speed blower relay energizes. The blower will begin operating and remain in operation until two minutes after the call for heat has been satisfied. This timing sequence guarantees blower on, blower off operation.

This unit is equipped with a flame rollout switch which is wired in series with the control circuit. This is a manual reset switch and is used for the purpose of preventing possible fire hazard in the event of a system malfunction. If this switch has opened the control circuit, there could be a possible system malfunction. Some of the conditions that might cause a rollout to occur are blockage or sooting of primary heat exchanger, over-firing of furnace due to improper main burner orifices or incorrect manifold pressure, insufficient combustion air, or installation deficiencies with respect to return air duct design or sizing.

Once the problem has been resolved, reset the switch by pressing down on the black button on top of the switch.

MAINTENANCE INSTRUCTIONS

The furnace and its vent system should be inspected annually by a qualified service agency, generally prior to the heating season.

NOTE: PRIOR TO THE START OF ANY OF THE FOLLOWING MAINTENANCE PROCEDURES SHUT OFF ALL POWER TO THE UNIT.

Routine maintenance procedures are the responsibility of the owner and are contained in the Owner's Manual. These are briefly outlined below:

1. Air Filters. Check the condition on at least a monthly basis when the furnace is in use or replace whenever it is necessary.
2. Lubrication Requirements. Direct drive motors are permanently lubricated, no maintenance required. The induced draft blower motor should be oiled every six months with SAE20 motor oil.
3. Periodic Inspection of the Vent and Air Intake. Visual inspection of the vent and air intake for any leaking, sags, dips or defective parts. The vent and intake should also be inspected outside of the structure for any blockage in the openings. If blockage is present, remove the bird screens and brush clean before putting them back in.
4. Periodic Inspection of Drain Line. The drain line on a condensing furnace should be checked monthly for blockage or freezing of drain condensate. Blockage of drain will prevent furnace operation.

--QUALIFIED TECHNICIANS ONLY--

Service Agency Procedures

The pilot flame can be adjusted by removing the pilot adjustment cover screw. Turn inner adjustment screw clockwise to decrease and counterclockwise to increase pilot flame. Be sure to replace cover screw after adjustment to prevent possible gas leakage.

Observe the main burners in operation. The flame should be mostly "blue" with possibly a little orange (not yellow) at the tips of the flame. The flames should be in the center of the heat exchanger compartments and not impinging on the heat exchanger surfaces themselves.

The air shutters are factory adjusted completely open. If flashback occurs, the air shutters may be closed slightly to prevent the flashback.

Observe the fire until the blower starts (there is a normal delay period until the heat exchanger warms up). There should be no change in the size or shape of the flame. If there is any wavering or blowing of the flame on blower start-up, it is an indication of a possible leak in the heat exchanger.

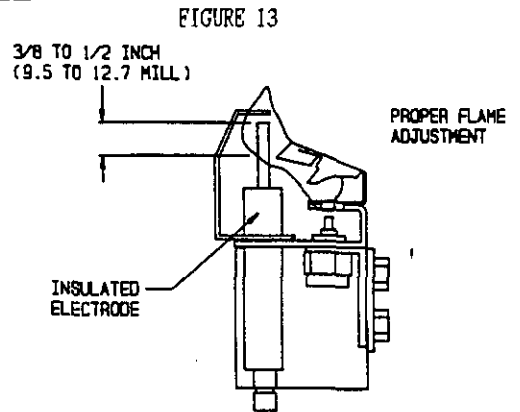
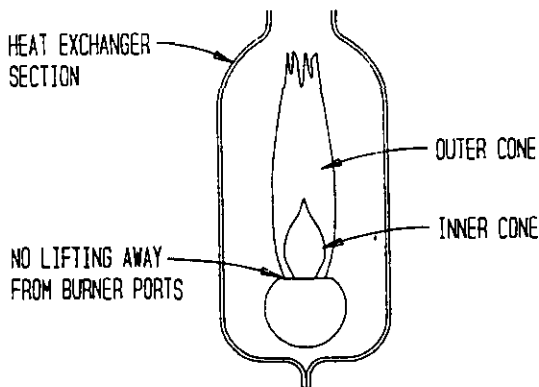

FIGURE 14



WARNING

Danger of property damage, bodily injury or death if electric power (at disconnect) and gas supply (at manual shutoff valve in gas line) are not shut off.

Inspect the burner assembly for any scaling, sooting or blockage of ports. If there are signs of this, the burner should be removed and cleaned with a wire brush until all soot and scale is removed and burner ports are not obstructed.

Check Temperature Rise--Adjust blower speed if necessary to obtain a temperature rise within the range specified on the furnace rating plate. See blower operation for details.

Heat Exchangers and Flue Gas Passageways

Furnaces that are properly installed and maintained will normally not require cleaning of the heat exchangers.

THE ONLY TIME it should be necessary to disassembly and clean the interior of both the Primary and Secondary Heat Exchangers would be due a sooting condition caused by abnormal combustion.

The inside of the heat exchanger can be examined for scale and soot using a light and a mirror on an extension handle. If soot and/or scale is evident, the heat exchanger must be cleaned as follows:

1. Remove burner assembly from inlet to heat exchanger.
2. Remove flue transition, combustion air blower, flue collector box and internal flue baffles from the outlet of the primary heat exchanger.
3. Using a small wire brush on extension handle brush inside walls of the heat exchanger until soot and/or scale is removed. The loose scale and/or soot is easily removed using a vacuum cleaner at the inlet side of the heat exchanger.
4. To clean the secondary heat exchanger, disconnect the 2 no-hub connectors securing the vent to the furnace. Remove the length of vent located in the furnace vestibule. Remove the 18 sheet metal screws securing the coil partition (partition located on left side when facing unit). Disconnect drain hose and remove burner partition. The secondary heat exchanger is now ready for removal.
5. Gently ease secondary heat exchanger straight forward away from back of furnace being careful not to damage the fins.
6. Once the coil is removed from the furnace, take it to a place where the following steps can be performed.
 - A. Set coil on its back so the inlet, outlet and drain openings are pointed up. Pour 2 quarts of hot water into the coil and cap off openings. Shake coil vigorously and pour out water. Repeat this procedure until the water being poured from the coil is clear.
 - B. Thoroughly wash off the exterior of the heat exchanger using a soft brush and a mild stream of water. DO NOT use a hard stream of water as this may damage the fins.

REPLACEMENT PARTS

Replacement parts for the gas furnaces are available through local distributor.

Parts list covering all furnace components is shown in the Replacement Parts Manual. When ordering parts or making inquiries pertaining to any of the furnaces covered by these instructions, it is very important to always supply the COMPLETE model number and serial number of the furnace. This is necessary to assure that the correct parts (or an approved alternate part) are issued to the service agency.

CONNECTION DIAGRAM

DANGER: ELECTRICAL SHOCK HAZARD.
DISCONNECT POWER BEFORE SERVICING.

LADDER DIAGRAM

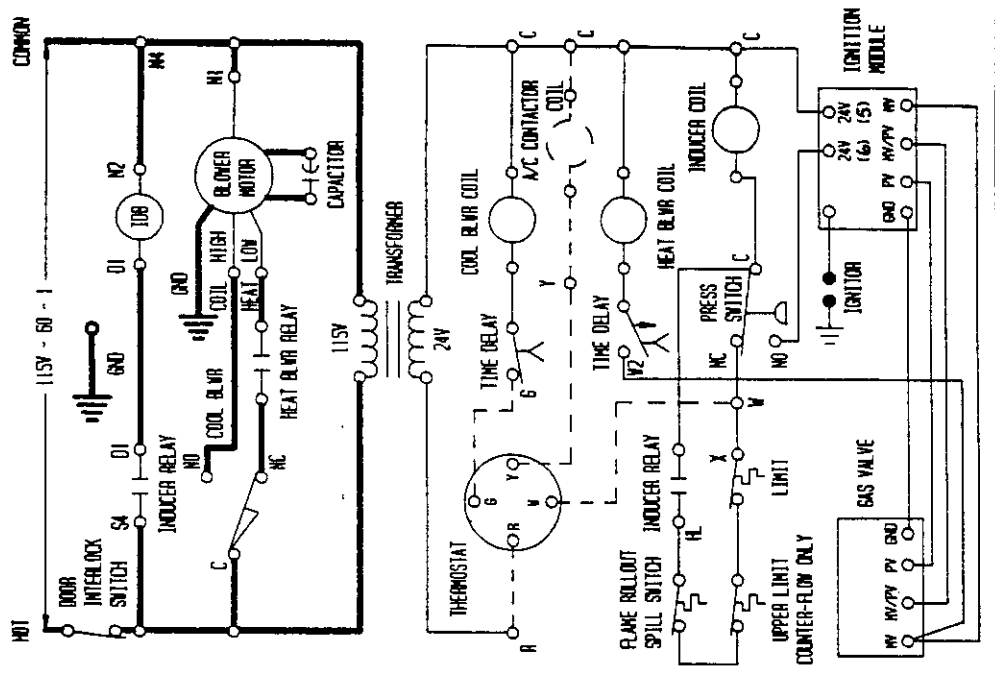
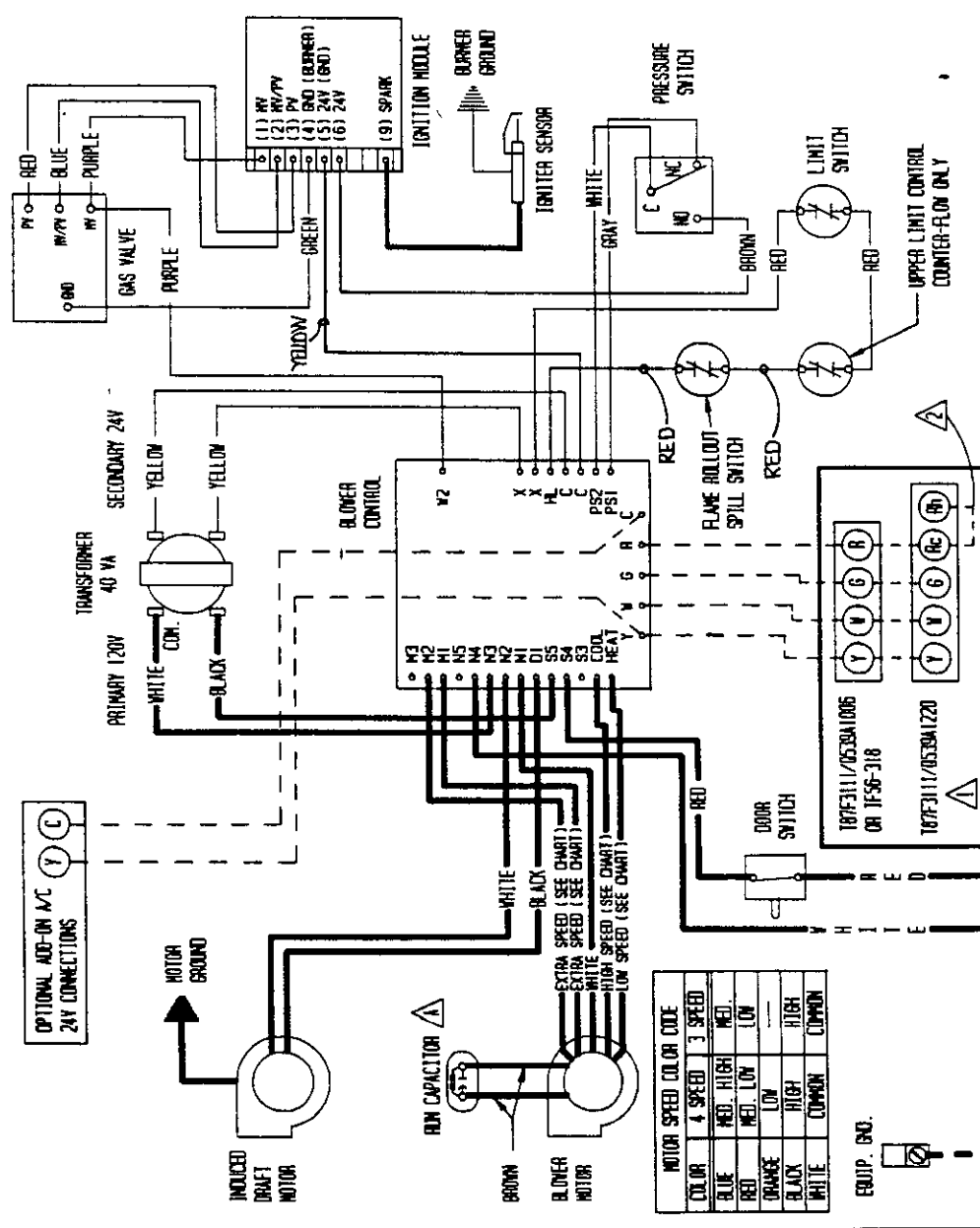

MODEL	RUN CAPACITOR	FACTORY WIRING	FIELD WIRING
CC & CH050	5/370	---	---
CC & CH000	7.5/370	---	---
CC & CH100	15/770	---	---

USE COPPER CONDUCTORS ONLY

Low Voltage
High Voltage

187F311/0538A1086 OR 1F56-318
107F311/0538A1220

115-60-1

SET HEAT ANTICIPATOR AT .8 A FOR ALL THERMOSTATS.

ADDED JUMPER R1-R4

IF ANY OF THE ORIGINAL WIRE AS SUPPLIED WITH THE APPLIANCE MUST BE REPLACED, IT MUST BE REPLACED WITH WIRING MATERIAL HAVING A TEMPERATURE RATING OF AT LEAST 105° C. EXCEPT THE IGNITION CABLE WHICH IS 250° C. HIGH VOLTAGE CABLE.

4046-108G

MOTOR SPEED COLOR CODE			
COLOR	4 SPEED	3 SPEED	
BLUE	MED. HIGH	MED.	
RED	MED. LOW	LOW	
ORANGE	LOW		
BLACK	HIGH	HIGH	
WHITE	COMMON	COMMON	

XVIII. S8600H INTERMITTENT PILOT SYSTEM TROUBLESHOOTING

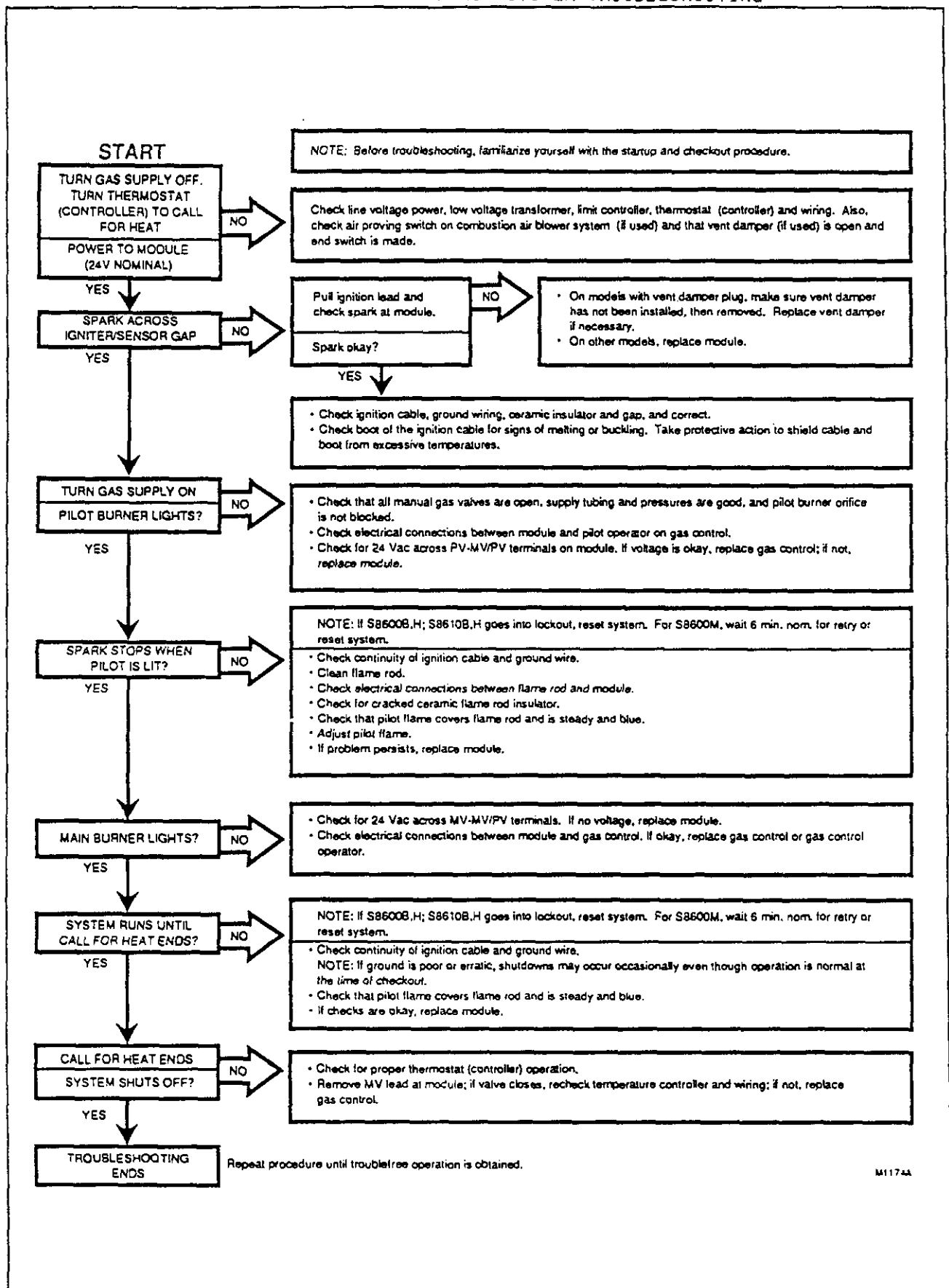

M1174A

