

# **INSTALLATION INSTRUCTIONS**

## **SPLIT AIR CONDITIONER OUTDOOR SECTION**

### **MODELS**

**2412UACSB**

**3012UACSB**

**3612UACSB**

**4212UACSB**

**4812UACSB**

**6012UACSB**

**FOR USE WITH:  
MATCHING INDOOR BLOWER  
COIL UNITS AND MATCHING  
ADD ON COIL UNITS ONLY**

**DATE: 03-28-96**

**MANUAL 2100-169 J  
SUPERSEDES REV. I  
FILE VOL. I, TAB 4**

TABLE OF CONTENTS

I. Application and Location . . . . . 4  
  General . . . . . 4  
  Shipping Damage . . . . . 4  
  Application . . . . . 4  
  Location . . . . . 5  
  Mounting Unit Outside on Slab . . . . . 5  
  Important Installer Note . . . . . 5  
  Installing Refrigerant Tubing . . . . . 5  
  Sweat Style Tubing Connections: Sweat Indoor Unit & Sweat Outdoor Unit. 6  
  Field Fabricated Tubing Connections: Quick Connect Indoor Unit & Sweat. 8  
    Outdoor Unit Using CTO Kit

II. Wiring Instructions . . . . . 10  
  General . . . . . 10  
  Control Circuit Wiring . . . . . 10  
  Discharge Temperature Sensor (2412- 4212 Models) . . . . . 14  
  Wall Thermostats . . . . . 14

III. Charging Instructions . . . . . 14  
  Pressure Service Ports . . . . . 14  
  System Start-Up (Non-TXV Indoor Units). . . . . 15  
  System Start-Up (TXV Indoor Units). . . . . 16

IV. Service . . . . . 18  
  Service Hints . . . . . 18  
  Fan Blade Setting Dimensions . . . . . 18  
  Unbrazing System Components . . . . . 18  
  Wiring Diagrams . . . . . 19-20  
  Pressure Tables . . . . . 22-24

## FIGURES AND TABLES

|          |    |
|----------|----|
| Figure 1 | 1  |
| Figure 2 | 4  |
| Figure 3 | 5  |
| Figure 4 | 6  |
| Figure 5 | 14 |
| Figure 6 | 14 |

|          |    |
|----------|----|
| Table 1  | 1  |
| Table 2  | 2  |
| Table 3  | 3  |
| Table 3A | 7  |
| Table 4  | 10 |
| Table 5  | 11 |
| Table 6  | 11 |
| Table 7  | 14 |
| Table 8  | 15 |
| Table 9  | 15 |
| Table 10 | 16 |
| Table 11 | 16 |
| Table 12 | 17 |
| Table 13 | 18 |
| Table 14 | 22 |
| Table 15 | 22 |
| Table 16 | 23 |
| Table 17 | 23 |
| Table 18 | 24 |
| Table 19 | 24 |

FIGURE 1

NOMENCLATURE EXPLANATION - Example:

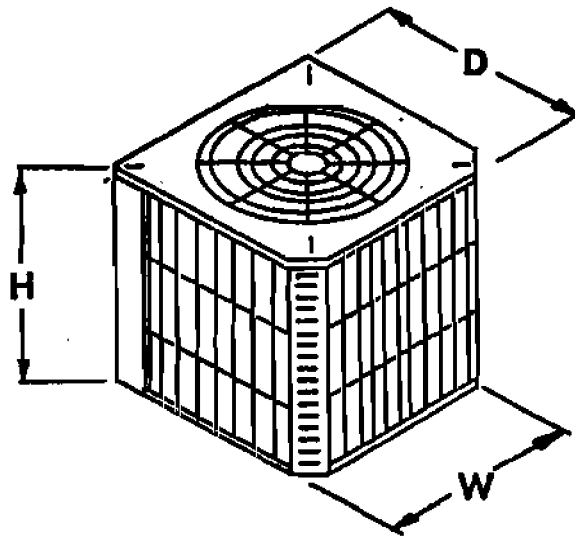
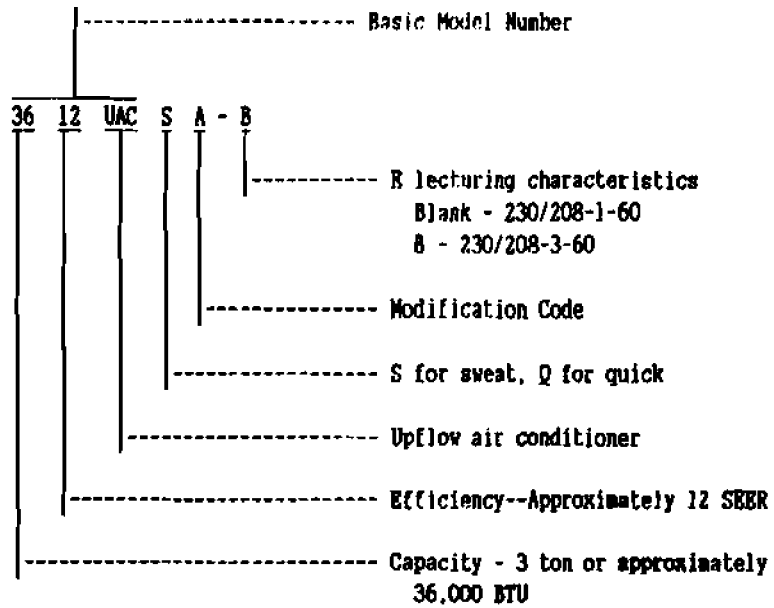

TABLE 1

| Basic Model No. | DIMENSIONS |           |            |
|-----------------|------------|-----------|------------|
|                 | "W" Width  | "D" Depth | "H" Height |
| 2412UACSB       | 32-1/2     | 32-1/2    | 26"        |
| 3012UACSB       |            |           |            |
| 3612UACSB       |            |           |            |
| 4212UACSB       | 32-1/2     | 32-1/2    | 36"        |
| 4812UACSB       |            |           |            |
| 6012UACSB       |            |           |            |

**TABLE 2 RATED CFM AND AIR FLOW DATA (WBT COIL--COOLING)**

| Condensing Unit Model Number | Evaporator Coil Model Number | Rated Airflow |                              | Rated E.S.P. (2) | Motor Speed Tap | Recommended Air Flow Range | System Orifice Required |
|------------------------------|------------------------------|---------------|------------------------------|------------------|-----------------|----------------------------|-------------------------|
|                              |                              | CFM           | Pressure Drop $\Delta$ P (1) |                  |                 |                            |                         |
| 2412UACSB                    | A36AS-A                      | 820           | .15                          | .15              | High            | 700 - 910                  | .061*                   |
|                              | BC24B                        | 775           |                              |                  |                 | 680 - 890                  | .059                    |
| 3012UACSB                    | A36AS-A                      | 1050          | .20                          | .10<br>.21       | High<br>Low     | 900 - 1325                 | .067                    |
|                              | BC30B                        | 800           |                              |                  |                 | 700 - 910                  | .063                    |
|                              | BC36B                        | 1050          |                              |                  |                 | 900 - 1325                 | .067*                   |
| 3612UACSB                    | A36AS-A                      | 1200          | .30                          | .20              | High            | 1020 - 1320                | .072*                   |
|                              | A37AS-A                      | 1200          | .25                          |                  |                 | 1020 - 1320                | .072                    |
|                              | BC36B                        | 1200          |                              |                  |                 | 1020 - 1320                | .072                    |
| 4212UACSB                    | A4BAS-A                      | 1325          | .20                          | .15              | High            | 1125 - 1450                | .081                    |
|                              | BC36B                        | 1240          |                              |                  |                 | 1060 - 1360                | .081*                   |
| 4812UACSB                    | A61XS-A                      | 1600          | .25                          | .38              | Low             | 1360 - 1760                | TKV                     |
|                              | BC60BX                       | 1600          |                              |                  |                 | 1360 - 1760                | TKV                     |
| 6012UACSB                    | A61XS-A                      | 1780          | .30                          | .30              | High            | 1500 - 1950                | TKV                     |
|                              | BC60BX                       | 1800          |                              |                  |                 | 1525 - 1975                | TKV                     |

(1) Measured across the evaporator coil assembly, including drain pan.

(2) External static pressure available for the duct system - supply and return. All blower coils have multi-speed motors, and value shown is at the recommended rated speed. Consult specification air flow charts with the blower coil units for complete information at other speeds.

**\*IMPORTANT**

Proper sized orifice is not factory installed in indoor section. Proper orifice size is shipped with outdoor unit packaged with its installation instructions for indoor sections listed on this page. The orifice must be replaced with the proper system orifice shown above in Table 2.

For other evaporator coil models not listed, see indoor coil installation instructions for proper orifice information.

TABLE 3

## SPECIFICATIONS--SPLIT AIR CONDITIONING

| MODEL   | 2412UACSB  | 3012UACSB  | 3612UACSB  | 4212UACSB  | 4812UACSB  | 6012UACSB  |
|---|------------|------------|------------|------------|------------|------------|
| <b>ELECTRICAL RATING (60Hz/V/Ph)</b>                    | 230/208-1  | 230/208-1  | 230/208-1  | 230/208-1  | 230/208-1  | 230/208-1  |
| Operating Voltage Range                                 | 197-253    | 197-253    | 197-253    | 197-253    | 197-253    | 197-253    |
| Minimum Circuit Ampacity                                | 14         | 18         | 22         | 24         | 31         | 38         |
| *Field Wire Size  | #14        | #12        | #10        | #10        | #8         | #8         |
| **Delay Fuse Max. or Ckt. Bkr.                          | 20         | 30         | 35         | 40         | 50         | 60         |
| Total Unit Amps 230/208                                 | 9.1/10.1   | 11.6/12.1  | 14.1/14.6  | 18.5/17.5  | 17.8/20.3  | 23.3/25.8  |
| <b>COMPRESSOR</b>                                       |            |            |            |            |            |            |
| Volts   | 230/208    | 230/208    | 230/208    | 230/208    | 230/208    | 230/208    |
| Rated Load Amps 230/208                                 | 8/9        | 10.5/11    | 13/13.5    | 17/16      | 16.5/19    | 22/24.5    |
| Branch Circuit Selection Current                        | 10.3       | 13.5       | 16         | 17.9       | 23.7       | 28.8       |
| Lock Rotor Amps 230/208                                 | 56/56      | 72.5/72.5  | 88/88      | 104/104    | 129/129    | 169/169    |
| <b>FAN MOTOR &amp; CONDENSER</b>                        |            |            |            |            |            |            |
| Fan Motor--HP/RPM                                       | 1/6 - 825  | 1/6 - 825  | 1/6 - 825  | 1/4 - 825  | 1/3 - 1075 | 1/3 - 1075 |
| Fan Motor--AMPS   | 1.1        | 1.1        | 1.1        | 1.5        | 1.3        | 1.3        |
| Fan--DIA/CFM  | 24" - 3000 | 24" - 3000 | 24" - 3000 | 24" - 3100 | 24" - 3100 | 24" - 3100 |
| <b>REFRIGERANT CONNECTION AND CHG.</b>                  |            |            |            |            |            |            |
| Suction Line Size                                       | 7/8"       | 7/8"       | 7/8"       | 7/8"       | 7/8"       | 7/8"       |
| Liquid Line Size  | 3/8"       | 3/8"       | 3/8"       | 3/8"       | 3/8"       | 3/8"       |
| *60 degree C Copper wire size.                          |            |            |            |            |            |            |
| **Maximum time delay fuse or HACR Type circuit breaker. |            |            |            |            |            |            |

## I. APPLICATION AND LOCATION

### GENERAL

These instructions explain the recommended method to install the air cooled remote type condensing unit, the interconnecting refrigerant tubing, and the electrical wiring connections to the unit.

The condensing units are to be used in conjunction with the matching evaporator coils or evaporator blower units for comfort cooling applications as shown in the specification sheet.

These instructions and any instructions packaged with any separate equipment required to make up the entire air conditioning system should be carefully read before beginning the installation. Note particularly "Starting Procedure" and any tags and/or labels attached to the equipment.

While these instructions are intended as a general recommended guide, they do not supersede any national and/or local codes in any way. Authorities having jurisdiction should be consulted before the installation is made.

### SHIPPING DAMAGE

Upon receipt of equipment, the carton should be checked for external signs of shipping damage. If damage is found, the receiving party must contact the last carrier immediately, preferably in writing, requesting inspection by the carrier's agent.

### APPLICATION

Size of unit for a proposed installation should be based on heat loss calculation made according to methods of Air Conditioning Contractors of America. The air duct should be installed in accordance with the Standards of the National Fire Protection Association for the Installation of Air Conditioning and Ventilating Systems of Other Than Residence Type, NFPA No. 90A, and Residence Type Warm Air Heating and Air Conditioning Systems, NFPA 90B. Where local regulations are at a variance with instructions, installer should adhere to local codes.

FIGURE 2

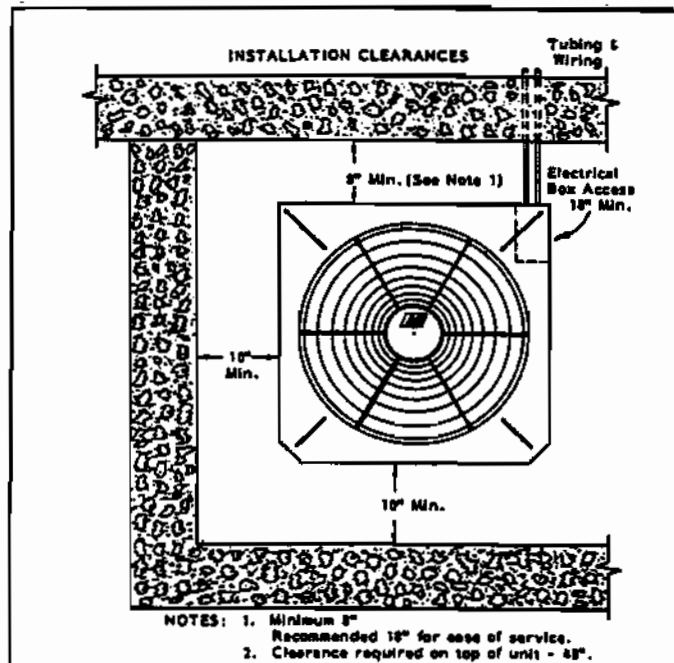

## LOCATION

The condensing unit is designed to be located outside with free and unobstructed condenser air inlet and discharge. It must also permit access for service and installation. Condenser air enters the coil on three sides and discharges upward from the top. Refrigerant and electrical connections are made from the rear of the unit as shown in Figure 2 with electrical service access on the right side. The unit can be installed with the rear of the unit "close to the wall", however, additional service clearance at the back of the unit would be desirable if practical for unit service. The compressor can be serviced through the top.

## MOUNTING UNIT OUTSIDE ON SLAB

A solid level base or platform, capable to support the unit's weight, must be set at the outdoor unit predetermined location. The base should be at least two inches larger than the base dimensions of the unit and at least two inches higher than surrounding grade level. The required unit minimum installed clearances must be maintained as called out in Figure 2 when locating and setting the base.

Remove the unit from its shipping carton and position the unit on the prepared base or platform.

Do not attach the unit or its base to the building structure to avoid the transmission of noise into the occupied area.

**NOTE:** These units employ internally sprung compressors; therefore, it is not necessary to remove or loosen the base mounting bolts on the compressor prior to operation.

Consideration should be given to the electrical and tubing connections when placing the unit to avoid unnecessary bends or length of material.

## IMPORTANT INSTALLER NOTE:

For improved start-up performance, wash the indoor coil with a dishwasher detergent.

## INSTALLING REFRIGERANT TUBING

The information that follows on installing refrigerant tubing and for changing the system orifice (if required) covers applications listed in the front of this installation instruction only. Although other indoor units may be of similar construction, the installation instructions for these units should be consulted for proper installation of those units prior to installation.

This information is provided for the field service personnel to install refrigerant tubing in compliance with Section 608 of Title VI National Recycling and Emission Reduction Program for the U.S. Clean Air Act effective July 1, 1992.

Consult manual 2100-002 on procedure for leak test--evacuation--charging before installation refrigerant tubing that requires any refrigerant recovery or system evacuation. Manual 2100-002 is included with the unit installation instruction package when shipped from the factory.

FIGURE 3

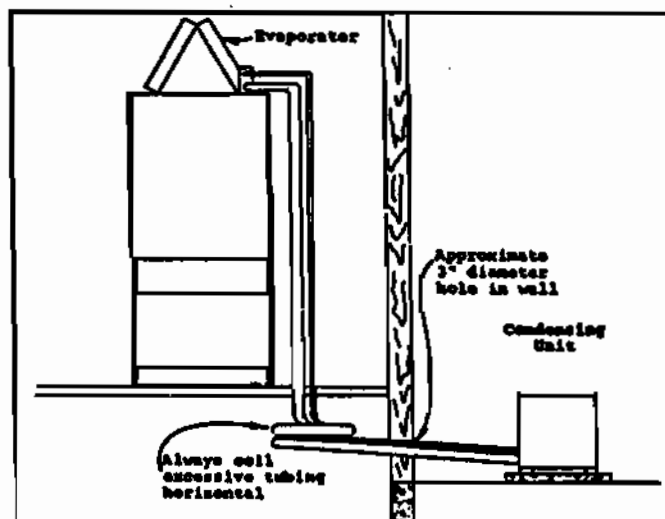



## SWEAT STYLE TUBING CONNECTIONS: SWEAT INDOOR UNIT AND SWEAT OUTDOOR UNIT

Use only refrigeration grade (dehydrated and sealed) copper tubing. Care must be taken to insure that the tubing is kept clean and dry before and during installation. Do not remove the plugs from the tubing ends, coil connections or base valves until the connection is ready to be brazed.

The suction line must be insulated with a minimum of 3/8" Armaflex or equivalent before cutting and making connections.

**STEP 1**--Being careful not to kink, route both the suction line and liquid line between the indoor unit and outdoor unit. Use a tubing bender to make any necessary bends in tubing. When necessary to bend the insulated tube suction line, cut the insulation around its circumference at a distance far enough beyond the point of the bend so as to clear the tubing bender. Slip the insulation back together and vapor seal the joint with tape. Coil any excess tubing in a horizontal place with the slope of the tubing toward the condensing unit.

**CAUTION:** 1. Be careful not to tear the insulation when pushing it through hole in masonry or frame walls. 2. When sealing the tube opening in house wall, use a soft material to prevent tube damage and vibration transmission. 3. Avoid excessive bending in any one place to avoid kinking.

**STEP 2**--The tubing ends should be cut square. Make sure it is round and free of burrs at the connecting ends. Clean the tubing to prevent contaminants from entering the system.

**NOTE:** DO NOT BRAZE LINE TO UNITS! If orifice needs to be changed, change out orifice first.

If the orifice does not have to be changed, skip the instructions outlined further in Step 3 and proceed to Step 8.

**STEP 3**--Disassemble Flow Control Assembly by turning body hex.

**STEP 4**--If existing orifice has not dropped out of the body when disassembled, remove by using a pin or paper clip. Discard this original orifice.

**STEP 5**--Insert proper sized orifice fully into the flow control body with rounded "bullet" nose towards the unit as shown. Insure the orifice stays inserted in body before connecting mating half. See chart in the outdoor unit installation instructions for proper size.

**CAUTION:** Be sure there is no dirt introduced into the flow control--orifice assembly. Be sure and install the orifice with the bullet nose pointing in the proper direction as shown in Figure 4. Failure to do so will result in improper operation.

FIGURE 4  
FLOW CONTROL ASSEMBLY  
FIELD ORIFICE REPLACEMENT INSTRUCTIONS

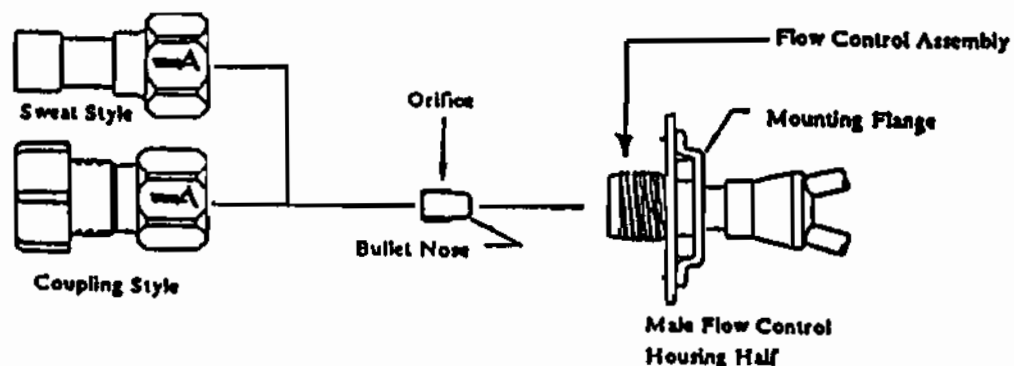

STEP 6--Thread assembly halves together by hand to insure proper mating of threads and tighten until bodies "bottom" or a definite resistance is felt.

STEP 7--Using a marker pen or ink pen, mark a line lengthwise from the union nut to the bulkhead. Then tighten an additional 1/6 turn (or 1 hex flat). The misalignment of the line will show the amount the assembly has been tightened. This final 1/6 turn is necessary to insure the formation of the leakproof joint.

STEP 8--Wrap a wet rag around the copper stub before brazing.

STEP 9--Flux the copper tube and insert into the stub. Braze the joint using an alloy of silver or copper and phosphorus with a melting temperature above 1100°F for copper to copper joints. The phosphorus will act as a flux, therefore, no flux will be required.

A copper-silver alloy with a high silver content should be used when iron or steel material is involved in the joint. These alloys require the use of silver solder flux. Alloys containing phosphorus should not be used with iron or steel. Phosphorus reacts with the iron, forming iron phosphate which is extremely brittle.

CAUTION: 1. Brazing alloys with a melting temperature below 700°F should not be used. 2. Lead-tin or tin-antimony solders should not be used due to their low melting point and necessity for corrosive fluxes.

To further prevent the formation of copper oxide inside the tubing, dry nitrogen may be purged through the refrigerant system during brazing.

\*\*\*\*\*

WARNING: Never purge or pressurize a system with oxygen. An explosion and fire will result.

\*\*\*\*\*

STEP 10--After brazing, quench with wet rag to cool the joint and remove any flux residue.

STEP 11--Leak test all connections using an electronic leak detector or a halide torch.

STEP 12--Evacuate suction line, liquid line, and indoor unit through outdoor unit base valves.

STEP 13--Open both the suction and liquid base valves to the fully open position. Refer to section later in installation instructions for details on setting proper system charge.

TABLE 3A

| Basic<br>Condensing<br>Unit Model | SWEAT STYLE TUBING CONNECTIONS<br>Refrigerant Line Length (Ft.) |                  |                  |
|-----------------------------------|---|------------------|------------------|
|                                   | 0 - 20  | 21 - 60          | 61 - 100         |
|                                   | Liquid & Suction  | Liquid & Suction | Liquid & Suction |
| All                               | 3/8 & 3/4   | 3/8 & 7/8        | 1/2 & 7/8        |

## FIELD FABRICATED TUBING CONNECTIONS: QUICK CONNECT INDOOR UNIT AND SWEAT OUTDOOR UNIT USING CTO KIT

Use only refrigeration grade (dehydrated and sealed) copper tubing. Care must be taken to insure that the tubing is kept clean and dry before and during installation. Do not remove the plugs from the tubing ends, coil connections or base valves until the connection is ready to be brazed.

The suction line must be insulated with a minimum of 3/8" Armaflex or equivalent before cutting and making connections.

**STEP 1--**Being careful not to kink, route both the suction line and liquid line between the indoor unit and outdoor unit. Use a tubing bender to make any necessary bends in tubing. When necessary to bend the insulated tube suction line, cut the insulation around its circumference at a distance far enough beyond the point of the bend so as to clear the tubing bender. Slip the insulation back together and vapor seal the joint with tape. Coil any excess tubing in a horizontal place with the slope of the tubing toward the condensing unit.

**CAUTION:** 1. Be careful not to tear the insulation when pushing it through hole in masonry or frame walls. 2. When sealing the tube opening in house wall, use a soft material to prevent tube damage and vibration transmission. 3. Avoid excessive bending in any one place to avoid kinking.

**STEP 2--**The tubing ends should be cut square. Make sure it is round and free of burrs at the connecting ends. Clean the tubing to prevent contaminants from entering the system.

|              |  |
|--------------|--|
| <b>NOTE:</b> | DO NOT make any tubing connection at indoor unit at this time. Make all brazing of joints and evacuate both suction and liquid line first. |
|--------------|--|

**STEP 3--**Wrap a wet rag around the copper stub before brazing.

**STEP 4--**Flux the copper tube and insert into the stub. Braze the joint using an alloy of silver or copper and phosphorus with a melting temperature above 1100°F for copper to copper joints. The phosphorus will act as a flux, therefore, no flux will be required.

A copper-silver alloy with a high silver content should be used when iron or steel material is involved in the joint. These alloys require the use of silver solder flux. Alloys containing phosphorus should not be used with iron or steel. Phosphorus reacts with iron, forming iron phosphate which is extremely brittle.

**CAUTION:** 1. Brazing alloys with a melting temperature below 700°F should not be used. 2. Lead-tin or tin-antimony solders should not be used due to their low melting point and necessity for corrosive fluxes.

To further prevent the formation of copper oxide inside the tubing, dry nitrogen may be purged through the refrigerant system during brazing.

\*\*\*\*\*

**WARNING:** Never purge or pressurize a system with oxygen. An explosion and fire will result.

\*\*\*\*\*

**STEP 5--**After brazing, quench with wet rag to cool the joint and remove any flux residue.

**STEP 6--**Leak test all connections using an electronic leak detector or a halide torch.

**STEP 7--**Evacuate suction line and liquid line through outdoor unit base valves.

If orifice does not have to be changed, skip the instructions outlined further in Step 8 and proceed to Step 15.

**STEP 8--**Recover charge from the indoor unit.

- A. Connect the suction line only to the indoor unit as outlined in Steps 15, 16 and 17.
- B. Recover indoor unit and suction line unit charge through service port located on outdoor unit base valve.

**STEP 9--**Disassemble Flow Control Assembly by turning body hex.

**STEP 10--**If existing orifice has not dropped out of the body when disassembled, remove by using a pin or paper clip. Discard this original orifice.

**STEP 11--**Insert proper sized orifice fully into the flow control body with rounded "bullet" nose towards the unit as shown. Insure the orifice stays inserted in body before connecting mating half. See chart in the outdoor unit installation instructions for proper size.

**CAUTION:** Be sure there is no dirt introduced into the flow control--orifice assembly. Be sure and install the orifice with the bullet nose pointing in the proper direction as shown in Figure 4. Failure to do so will result in improper operation.

**STEP 12--**Thread assembly halves together by hand to insure proper mating of threads and tighten until bodies "bottom" or a definite resistance is felt.

**STEP 13--**Using a marker pen or ink pen, mark a line lengthwise from the union nut to the bulkhead. Then tighten an additional 1/6 turn (or 1 hex flat). The misalignment of the line will show the amount the assembly has been tightened. This final 1/6 turn is necessary to insure the formation of the leakproof joint.

**STEP 14--**Evacuate the suction line and indoor unit through the outdoor unit base valve before connecting all other tubing. Refer to section later in installation instructions for details on setting the proper refrigerant charge.

**STEP 15--**Remove (remaining) protector caps and plugs (if orifice was changed). Inspect fittings and if necessary carefully wipe coupling seats and threaded surfaces with a clean cloth to prevent the inclusion of dirt or any foreign material in the system.

**STEP 16--**Lubricate male half diaphragm and synthetic rubber seal with refrigerant oil. Thread coupling halves together by hand to insure proper mating of threads. Be sure to hold the coupling firmly to prevent movement of the coupling and tubing. Failure to do so could tear out the diaphragm causing a blockage of the system. Use proper size wrenches (on coupling body hex and on union nut) and tighten until coupling bodies "bottom" or a definite resistance is felt.

**CAUTION:** After starting to tighten up the fitting, never try to back it off or take it apart.

**STEP 17--**Using a marker or ink pen, mark a line lengthwise from the coupling union nut to the bulkhead. Then tighten an additional 1/4 turn: The misalignment of the line will show the amount the coupling has been tightened. This final 1/4 turn is necessary to insure the formation of leak proof joint. If a torque wrench is used, the following torque values are recommended.

**TABLE 4**

| Coupling Size | Ft. Lbs. |
|---------------|----------|
| -6            | 10 - 12  |
| -10           | 35 - 45  |
| -11           | 35 - 45  |
| -12           | 50 - 65  |

**STEP 18--**Leak test all connections using an electronic leak detector or a halide torch.

**STEP 19--**When tubing is installed in attics or drop ceilings, insulate the couplings on the larger tube thoroughly with 3/8" wall thickness, closed cell sponge tube insulation or equivalent. Failure to insulate will result in water damage to ceiling since the fitting will "sweat" and drop water on the ceiling.

**STEP 20--**Open both the suction and liquid base valves to the fully open position. Refer to section later in installation instructions for details on setting proper system charge.

## **II. WIRING INSTRUCTIONS**

### **GENERAL**

All wiring must be installed in accordance with the National Electrical Code and local codes. In Canada, all wiring must be installed in accordance with the Canadian Electrical Code and in accordance with the regulations of the authorities having jurisdiction. Power supply voltage must conform to the voltage shown on the unit serial plate. A wiring diagram of the unit is attached to the inside of the electrical cover. The power supply shall be sized and fused according to the specifications supplied. A ground lug is supplied in the control compartment for equipment ground.

The unit rating plate lists a "Maximum Time Delay Fuse" or "BACR Type" circuit breaker that is to be used with the equipment. The correct size must be used for proper circuit protection and also to assure that there will be no nuisance tripping due to the momentary high starting current of the compressor motor.

### **CONTROL CIRCUIT WIRING**

For split systems, the minimum control circuit wiring gauge needed to insure proper operation of all controls in both indoor and outdoor units will depend on two factors.

1. The rated VA of the control circuit transformer.
2. The maximum total distance of the control circuit wiring. (This is the distance between the wall thermostat to the indoor unit plus the distance between the indoor unit to the outdoor unit.)

The following table should be used to determine proper gauge of control circuit wiring required.

**TABLE 5**

| Rated VA of Control Circuit Transformer | Transformer Secondary FLA @ 24V | Maximum Total Distance of Control Circuit Wiring In Feet                             |
|---|---------------------------------|--|
| 40                                      | 1.6                             | 20 gauge - 65<br>18 gauge - 90<br>16 gauge - 145<br>14 gauge - 230                   |
| 50                                      | 2.1                             | 20 gauge - 45<br>18 gauge - 60<br>16 gauge - 100<br>14 gauge - 160<br>12 gauge - 250 |
| 65                                      | 2.7                             | 20 gauge - 40<br>18 gauge - 55<br>16 gauge - 85<br>14 gauge - 135<br>12 gauge - 210  |

Example: 1. Control circuit transformer rated at 40VA.

2. Maximum total distance of control circuit wiring 85 feet.

From Table 5, minimum of 18 gauge wire should be used in the control circuit wiring.

For control circuit transformers rated other than those listed, use the next lower rated transformer listed.

Example: 1. Control circuit transformer rated at 55VA.

From table use 50VA transformer.

There are two (2) separate control diagrams for fossil fuel furnaces with air conditioners.

Control diagrams for the various circuits which could be encountered with blower coils can be found in the installation instructions of the blower coil.

**TABLE 6**

| System     | Gas Furnace Control Diagram | Oil Furnace Control Diagram |
|------------|-----------------------------|-----------------------------|
| All Models | 4091-100                    | 4091-101                    |

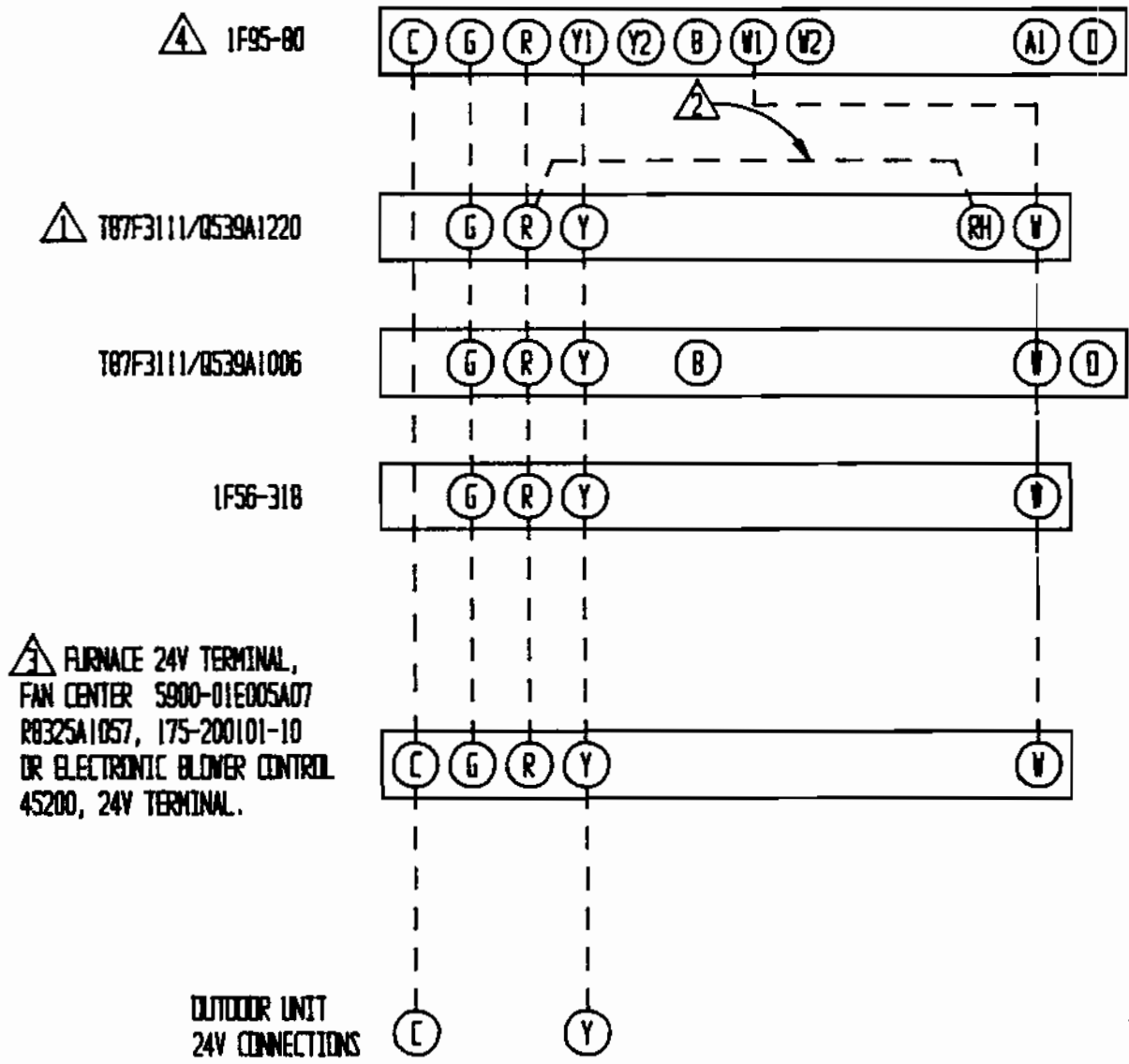

- ⚠ SET ADJUST HEAT ANTICIPATOR (SEE FURNACE INSTALLATION INSTRUCTIONS)
- ⚠ INSTALL JUMPER R-RH
- ⚠ IF THE FURNACE IS NOT INTERNALLY WIRED FOR ADD ON AIR CONDITIONING, A FAN CENTER WILL NEED TO BE ADDED.
- ⚠ OPTION SWITCH SETTING



SWITCH #1 "OFF"  
 SWITCH #2 "OFF"  
 SWITCH #3 "OFF"  
 SWITCH #4 SEE THERMOSTAT  
 INSTALLATION INSTRUCTIONS

|              | FACTORY WIRING | FIELD WIRING |
|--------------|----------------|--------------|
| LOW VOLTAGE  | _____          | -----        |
| HIGH VOLTAGE | _____          | -----        |

AIR CONDITIONER W/GAS FURNACE

⚠ T87F3111/0539A1220

⚠ FURNACE 24V TERMINAL  
 FAN CENTER 5900-01E005A07  
 R8325A1057, 175-200101-10  
 OR ELECTRONIC BLOWER CONTROL  
 45200, 24V TERMINAL.

OUTDOOR UNIT  
 24V CONNECTIONS

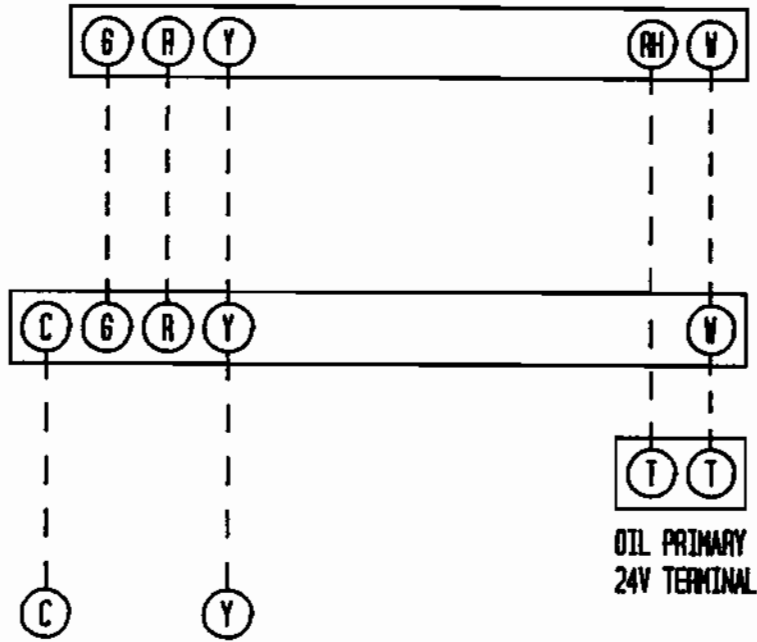

⚠ SET ADJUST HEAT ANTICIPATOR (SEE FURNACE INSTALLATION INSTRUCTIONS)

⚠ IF THE FURNACE IS NOT INTERNALLY WIRED FOR ADD ON AIR CONDITIONING, A FAN CENTER WILL NEED TO BE ADDED.

|              | FACTORY WIRING | FIELD WIRING |
|--------------|----------------|--------------|
| LOW VOLTAGE  | _____          | -----        |
| HIGH VOLTAGE | =====          | -----        |

AIR CONDITIONER W/OIL FURNACE

4091-101 A



## WALL THERMOSTATS

The following wall thermostats and subbases should be used as indicated, depending on the application.

TABLE 7

| AIR CONDITIONING THERMOSTATS |           |  |
|------------------------------|-----------|--|
| Part No.                     | Model No. | Description  |
| 8403-002                     | T87F3111  | THERMOSTAT--1 stg. heat, adj. heater, Mercury  |
| 8404-003                     | Q539A1220 | SUBBASE --System Heat-Off-Cool<br>Fan: On-Auto   |
| 8403-008                     | ID51-605  | THERMOSTAT--1 stg. cool, System w/Off Sw. Snap Action<br>Fan: Auto-On                                |
| 8403-009                     | IF56-318  | THERMOSTAT--1 st. cool, 1 stg. heat, Adj. heater<br>Mercury<br>System: Heat-Off-Cool<br>Fan: Auto-On |
| 8403-019                     | T874C1000 | THERMOSTAT--1 stg. cool, 2 stg. heat, Adj. heater,<br>Mercury  |
| 8404-012                     | Q674A1001 | SUBBASE --System: Heat-Auto-Cool<br>Fan: Auto-On   |

## III. CHARGING INSTRUCTIONS

### PRESSURE SERVICE PORTS

High and low pressure service ports are installed on all units so that the system operating pressures can be observed. Pressure tables can be found later in the manual covering all models. It is imperative to match the correct pressure table to the unit by model number.

### SYSTEM START-UP (INDOOR UNITS WITHOUT EXPANSION VALVES)

STEP 1--Close disconnect switch(es) and set the thermostat to cool and the temperature to the highest setting.

STEP 2--Check for proper airflow across the indoor coil by referring to indoor unit installation instructions.

STEP 3--Connect the service gauges and allow the unit to run for at least 10 minutes or until pressures are stable. Check pressures to the system pressure table attached to the outdoor unit service panel. For optimum system performance, go to Step 4.

**STEP 4**--Install a thermometer on the suction line approximately 6" to 10" from the compressor. Optimum system performance will occur with a refrigerant charge resulting in a suction line superheat as determined from the following calculations.

- A. Measure outdoor air dry bulb temperature \_\_\_\_\_ °F
- B. Measure indoor air wet bulb temperature \_\_\_\_\_ °F
- C. Measure suction pressure \_\_\_\_\_ PSIG
- D. Measure suction line temperature \_\_\_\_\_ °F
- E. Determine optimum system superheat from Table 9 using outdoor air dry bulb (Step B) and indoor air wet bulb (Step A). \_\_\_\_\_ °F
- F. Determine saturated suction temperature from suction pressure using Table 8. \_\_\_\_\_ °F
- G. Determine system superheat:
  - Suction line temperature (Step D) \_\_\_\_\_ °F
  - Saturated suction temperature (Step F) \_\_\_\_\_ °F
  - = System superheat \_\_\_\_\_ °F
- H. Adjust the system superheat (Step G) to the optimum system superheat (Step E) by adding charge to lower the superheat or removing charge to raise the superheat.
- I. Check final system operating pressures to the system pressure tables as was done in Step 3.

**TABLE 8 SATURATED SUCTION TEMPERATURE (R-22)**

| Suction Pressure PSIG | Saturated Suction Temperature (Deg. F) |
|-----------------------|--|
| 50                    | 26                                     |
| 53                    | 28                                     |
| 55                    | 30                                     |
| 58                    | 32                                     |
| 61                    | 34                                     |
| 63                    | 36                                     |
| 65                    | 38                                     |
| 67                    | 39                                     |
| 70                    | 41                                     |
| 73                    | 43                                     |
| 76                    | 45                                     |
| 79                    | 47                                     |
| 82                    | 49                                     |
| 86                    | 51                                     |

**TABLE 9 SYSTEM SUPERHEAT**

| Outdoor Ambient Temperature (Deg. F Dry Bulb) | Return Air Temperature Deg. F--Net Bulb |    |     |    |
|---|---|----|-----|----|
|   | 59                                      | 63 | 67  | 71 |
| 105   | 1                                       | 1  | 5   |    |
| 95  | 1                                       | 3  | (8) | 20 |
| 90  | 1                                       | 7  | 14  | 26 |
| 85  | 3                                       | 9  | 19  | 33 |
| 80  | 8                                       | 14 | 25  | 39 |
| 75  | 10                                      | 20 | 30  | 42 |

## SYSTEM START-UP (TXV INDOOR UNITS WITH EXPANSION VALVES)

**STEP 1**--Close disconnect switch(es) and set the thermostat to cool and the temperature to the highest setting.

**STEP 2**--Check for proper airflow across the indoor coil by referring to indoor unit installation instructions.

**STEP 3**--Connect the service gauges and allow the unit to run for at least 10 minutes or until pressures are stable. Check pressures to the system pressure table attached to the outdoor unit service panel. For optimum system performance, go to Step 4.

**NOTE:** Use a digital thermometer for all temperature measurements.

**STEP 4**--Install a thermometer on the liquid line approximately 4" to 6" from the base valve or quick connect on the outside of the unit. Optimum system performance will occur with a refrigerant charge resulting in a liquid line subcooling as determined from the following calculations.

- A. Measure liquid pressure \_\_\_\_\_ PSIG
- B. Measure liquid line temperature \_\_\_\_\_ °F
- C. Determine optimum system subcooling from Table 10 \_\_\_\_\_ °F
- D. Determine saturated liquid temperature from liquid pressure using Table 11. \_\_\_\_\_ °F
- E. Determine system subcooling:
- |                                       |            |
|---------------------------------------|------------|
| Saturated liquid temperature (Step D) | _____ °F   |
| - Liquid line temperature (Step B)    | - _____ °F |
| - System subcooling                   | = _____ °F |
- F. Adjust the system subcooling to the optimum system subcooling by adding charge to increase subcooling or removing charge to decrease subcooling. (Allow tolerance of  $\pm 3^\circ\text{F}$ )

**TABLE 10** REQUIRED SYSTEM SUBCOOLING

| Outdoor Section | Indoor Section |     |
|-----------------|----------------|-----|
| 4812UACSB       | A61XS-A        | 13° |
| 4812UACSB       | BC60BX         | 12° |
| 6012UACSB       | A61XS-A        | 17° |
| 6012UACSB       | BC60BX         | 15° |

**TABLE 11** SATURATED LIQUID TEMPERATURE

| Liquid Pressure | Saturated Liquid Temperature (Degree F) | Liquid Pressure | Saturated Liquid Temperature (Degree F) |
|-----------------|---|-----------------|---|
| 182             | 95                                      | 253             | 118                                     |
| 185             | 96                                      | 256             | 119                                     |
| 187             | 97                                      | 260             | 120                                     |
| 190             | 98                                      | 263             | 121                                     |
| 193             | 99                                      | 267             | 122                                     |
| 196             | 100                                     | 271             | 123                                     |
| 199             | 101                                     | 274             | 124                                     |
| 202             | 102                                     | 278             | 125                                     |
| 205             | 103                                     | 282             | 126                                     |
| 208             | 104                                     | 285             | 127                                     |
| 211             | 105                                     | 289             | 128                                     |
| 214             | 106                                     | 293             | 129                                     |
| 217             | 107                                     | 297             | 130                                     |
| 220             | 108                                     | 301             | 131                                     |
| 223             | 109                                     | 305             | 132                                     |
| 226             | 110                                     | 309             | 133                                     |
| 230             | 111                                     | 313             | 134                                     |
| 233             | 112                                     | 317             | 135                                     |
| 236             | 113                                     | 321             | 136                                     |
| 239             | 114                                     | 325             | 137                                     |
| 243             | 115                                     | 329             | 138                                     |
| 246             | 116                                     | 333             | 139                                     |
| 250             | 117                                     | 337             | 140                                     |

**TABLE 12**

| <b>TOTAL SYSTEM OPERATING CHARGE</b><br>(Includes charge for the basic outdoor unit, indoor coil and 25' of interconnecting tubing) |                |                         |
|---|----------------|-------------------------|
| Outdoor Section   | Indoor Section | Total R-22 Charge (Oz.) |
| 2412UACSB   | A36AS-A        | 107 oz.                 |
|   | BC24B          | 116 oz.                 |
| 3012UACSB   | A36AS-A        | 100 oz.                 |
|   | BC30B          | 102 oz.                 |
|   | BC36B          | 110 oz.                 |
| 3612UACSB   | A36AS-A        | 162 oz.                 |
|   | A37AS-A        | 173 oz.                 |
|   | BC36B          | 172 oz.                 |
| 4212UACSB   | A48AS-A        | 213 oz.                 |
|   | BC36B          | 197 oz.                 |
| 4812UACSB   | A61XS-A        | 227 oz.                 |
|   | BC60BX         | 227 oz.                 |
| 6012UACSB   | A61XS-A        | 234 oz.                 |
|   | BC60BX         | 234 oz.                 |

The above includes 25' of 3/8" diameter liquid line. For other than 25' and other tube sizes, adjust the total charge according to the following schedule.

| <u>Liquid Line Diameter</u> | <u>Oz. R-22 Per Ft.</u> |
|-----------------------------|-------------------------|
| 3/8"                        | .6                      |
| 1/2"                        | 1.2                     |

**INSTALLER NOTE:** Stamp or mark the final system charge determined above on the outdoor unit serial plate.

## IV. SERVICE

### SERVICE HINTS

1. Caution homeowner to maintain clean air filters at all times. Also, not to needlessly close off supply and return air registers. This reduces air flow through the system, which shortens equipment service life as well as increasing operating costs.
2. Check all power fuses or circuit breakers to be sure that they are the correct rating.
3. Periodic cleaning of the outdoor coil to permit full and unrestricted air flow circulation is essential.

### FAN BLADE SETTING DIMENSIONS

Shown in the drawing below are the correct fan blade setting dimensions for proper air delivery across the outdoor coil.

Any service work requiring removal or adjustment in the fan and/or motor area will require that the dimensions below be checked and blade adjusted in or out on the motor shaft accordingly.

FIGURE 7

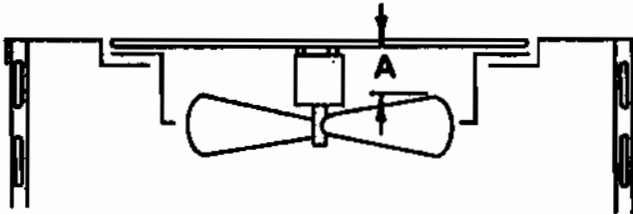
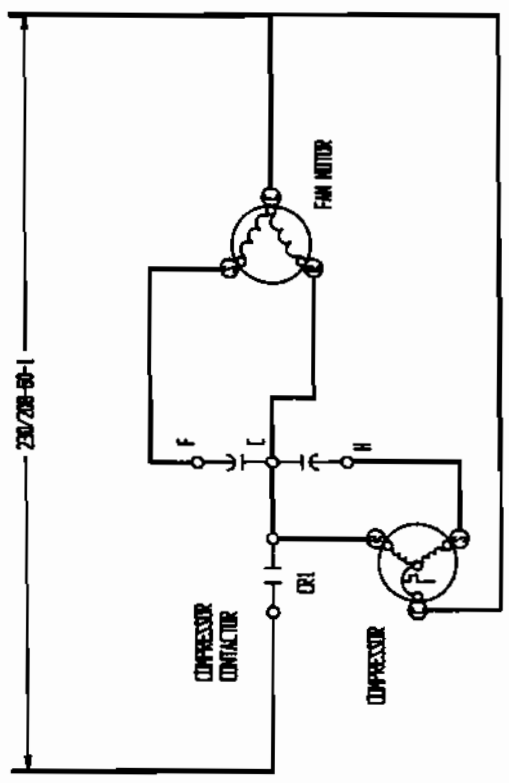
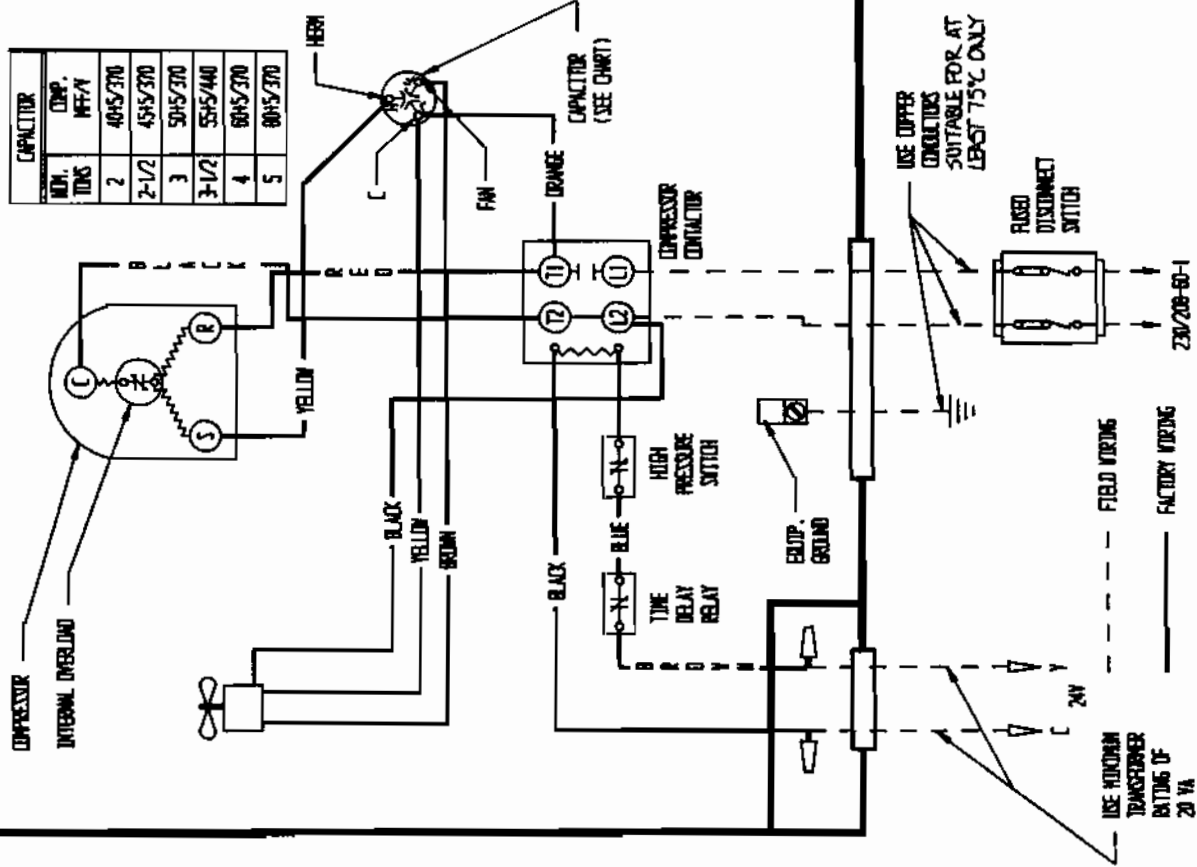

TABLE 13

| Model     | Dimension A |
|-----------|-------------|
| 2412UACSB | 3-1/2       |
| 3012UACSB |             |
| 3612UACSB |             |
| 4212UACSB |             |
| 4812UACSB | 4           |
| 6012UACSB |             |

### UNBRAZING SYSTEM COMPONENTS

If the refrigerant charge is removed from a scroll equipped unit by bleeding the high side only, it is sometimes possible for the scrolls to seal, preventing pressure equalization through the compressor. This may leave low side shell and suction line tubing pressurized. If the brazing torch is then applied to the low side while the low side shell and suction line contains pressure, the pressurized refrigerant and oil mixture could ignite when it escapes and contacts the brazing flame. To prevent this occurrence, it is important to check both the high and low side with manifold gauges before unbrazing.



HIGH VOLTAGE CIRCUIT

LOW VOLTAGE CIRCUIT ⚠

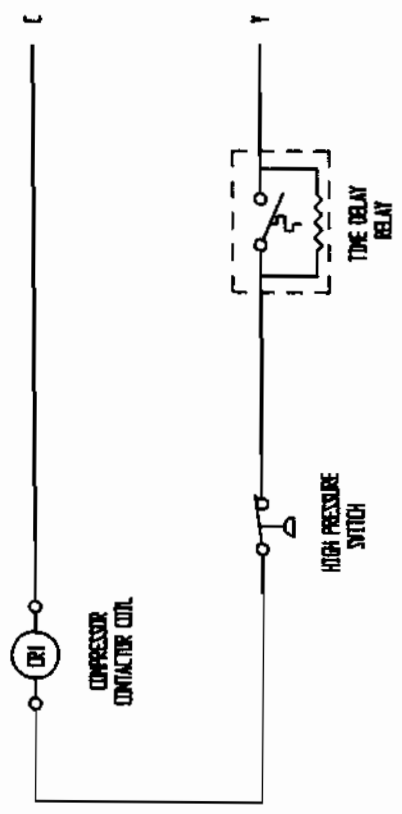

⚠ 24 VOLTS FOR LOW VOLTAGE CONTROL CIRCUIT SUPPLIED BY INDOOR UNIT TRANSFORMER

| COOLING                        |                        |           | Air Temperature Entering Outdoor Coil Degree F |     |     |     |     |     |     |     |     |
|--------------------------------|------------------------|-----------|--|-----|-----|-----|-----|-----|-----|-----|-----|
| Model                          | Return Air Temperature | Pressure  | °  | °   | °   | °   | °   | °   | °   | °   | °   |
|                                |                        |           | 75   | 80  | 85  | 90  | 95  | 100 | 105 | 110 | 115 |
| A36AS-A<br>Rated<br>CFM<br>820 | 75 deg. DB             | Low Side  | 68   | 71  | 73  | 75  | 77  | 78  | 79  | 80  | 80  |
|                                | 62 deg. WB             | High Side | 165  | 179 | 194 | 209 | 224 | 240 | 256 | 273 | 291 |
|                                | 80 deg. DB             | Low Side  | 74   | 76  | 78  | 80  | 82  | 83  | 85  | 85  | 86  |
|                                | 67 deg. WB             | High Side | 170  | 184 | 199 | 214 | 230 | 246 | 263 | 281 | 299 |
| BC24B<br>Rated<br>CFM<br>775   | 85 deg. DB             | Low Side  | 80   | 82  | 84  | 86  | 88  | 89  | 91  | 91  | 92  |
|                                | 72 deg. WB             | High Side | 177  | 191 | 206 | 222 | 238 | 255 | 272 | 290 | 309 |
|                                | 75 deg. DB             | Low Side  | 72   | 73  | 75  | 76  | 77  | 78  | 79  | 80  | 81  |
|                                | 62 deg. WB             | High Side | 172  | 186 | 201 | 215 | 230 | 245 | 260 | 276 | 292 |
| BC24B<br>Rated<br>CFM<br>775   | 80 deg. DB             | Low Side  | 78   | 79  | 81  | 82  | 83  | 84  | 85  | 86  | 87  |
|                                | 67 deg. WB             | High Side | 177  | 191 | 206 | 221 | 236 | 252 | 267 | 284 | 300 |
|                                | 85 deg. DB             | Low Side  | 84   | 85  | 87  | 88  | 89  | 90  | 91  | 92  | 93  |
|                                | 72 deg. WB             | High Side | 183  | 198 | 213 | 228 | 244 | 260 | 276 | 293 | 310 |

| COOLING                         |                        |           | Air Temperature Entering Outdoor Coil Degree F |     |     |     |     |     |     |     |     |
|---------------------------------|------------------------|-----------|--|-----|-----|-----|-----|-----|-----|-----|-----|
| Model                           | Return Air Temperature | Pressure  | °  | °   | °   | °   | °   | °   | °   | °   | °   |
|                                 |                        |           | 75   | 80  | 85  | 90  | 95  | 100 | 105 | 110 | 115 |
| A36AS-A<br>Rated<br>CFM<br>1050 | 75 deg. DB             | Low Side  | 70   | 71  | 73  | 74  | 75  | 76  | 77  | 78  | 79  |
|                                 | 62 deg. WB             | High Side | 172  | 183 | 196 | 209 | 224 | 240 | 257 | 276 | 296 |
|                                 | 80 deg. DB             | Low Side  | 74   | 76  | 78  | 80  | 81  | 82  | 83  | 84  | 85  |
|                                 | 67 deg. WB             | High Side | 177  | 188 | 201 | 215 | 230 | 247 | 264 | 284 | 304 |
| BC30B<br>Rated<br>CFM<br>800    | 85 deg. DB             | Low Side  | 80   | 82  | 84  | 86  | 87  | 88  | 89  | 90  | 91  |
|                                 | 72 deg. WB             | High Side | 182  | 194 | 207 | 222 | 238 | 255 | 274 | 294 | 315 |
|                                 | 75 deg. DB             | Low Side  | 66   | 68  | 69  | 70  | 71  | 72  | 73  | 74  | 75  |
|                                 | 62 deg. WB             | High Side | 167  | 182 | 197 | 213 | 229 | 245 | 262 | 278 | 295 |
| BC36B<br>Rated<br>CFM<br>1050   | 80 deg. DB             | Low Side  | 71   | 76  | 74  | 75  | 76  | 77  | 78  | 79  | 80  |
|                                 | 67 deg. WB             | High Side | 171  | 187 | 203 | 219 | 235 | 252 | 268 | 286 | 303 |
|                                 | 85 deg. DB             | Low Side  | 76   | 78  | 79  | 80  | 81  | 82  | 83  | 85  | 86  |
|                                 | 72 deg. WB             | High Side | 176  | 192 | 209 | 226 | 243 | 260 | 278 | 295 | 313 |
| BC36B<br>Rated<br>CFM<br>1050   | 75 deg. DB             | Low Side  | 72   | 73  | 75  | 76  | 77  | 78  | 79  | 79  | 80  |
|                                 | 62 deg. WB             | High Side | 166  | 181 | 196 | 211 | 227 | 243 | 259 | 275 | 292 |
|                                 | 80 deg. DB             | Low Side  | 76   | 78  | 80  | 82  | 83  | 84  | 85  | 86  | 86  |
|                                 | 67 deg. WB             | High Side | 171  | 186 | 201 | 217 | 233 | 249 | 266 | 283 | 300 |
| BC36B<br>Rated<br>CFM<br>1050   | 85 deg. DB             | Low Side  | 82   | 84  | 86  | 88  | 89  | 90  | 91  | 92  | 92  |
|                                 | 72 deg. WB             | High Side | 177  | 193 | 208 | 225 | 241 | 258 | 275 | 292 | 310 |

Low side pressure + 2 PSIG (suction line @ outdoor unit base valve)

High side pressure + 5 PSIG (liquid line @ outdoor unit base valve)

Tables are based upon rated CFM (airflow) across the evaporator coil and should be found under section titled "Refrigerant Charge" elsewhere in manual. If there is any doubt as to correct operating charge being in the system, the charge should be removed, system evacuated, and recharged to serial plate instructions.

## COOLING

Air Temperature Entering Outdoor Coil Degree F

| Model                           | Return Air Temperature | Pressure  | °   | °   | °   | °   | °   | °   | °   | °   | °   |
|---------------------------------|------------------------|-----------|-----|-----|-----|-----|-----|-----|-----|-----|-----|
|                                 |                        |           | 75  | 80  | 85  | 90  | 95  | 100 | 105 | 110 | 115 |
| A36AS-A<br>Rated<br>CFM<br>1200 | 75 deg. DB             | Low Side  | 66  | 68  | 70  | 72  | 73  | 74  | 75  | 76  | 77  |
|                                 | 62 deg. WB             | High Side | 168 | 183 | 198 | 214 | 231 | 248 | 266 | 284 | 302 |
|                                 | 80 deg. DB             | Low Side  | 71  | 73  | 75  | 77  | 78  | 79  | 80  | 81  | 82  |
|                                 | 67 deg. WB             | High Side | 172 | 188 | 204 | 220 | 237 | 254 | 272 | 291 | 310 |
| A37AS-A<br>Rated<br>CFM<br>1200 | 85 deg. DB             | Low Side  | 76  | 78  | 80  | 82  | 84  | 85  | 87  | 87  | 88  |
|                                 | 72 deg. WB             | High Side | 177 | 193 | 210 | 227 | 245 | 263 | 282 | 301 | 320 |
|                                 | 75 deg. DB             | Low Side  | 69  | 71  | 73  | 75  | 77  | 79  | 80  | 81  | 82  |
|                                 | 62 deg. WB             | High Side | 173 | 189 | 205 | 221 | 238 | 255 | 272 | 290 | 308 |
| BC36B<br>Rated<br>CFM<br>1200   | 80 deg. DB             | Low Side  | 74  | 76  | 78  | 80  | 82  | 84  | 85  | 87  | 88  |
|                                 | 67 deg. WB             | High Side | 177 | 193 | 210 | 227 | 244 | 262 | 279 | 298 | 316 |
|                                 | 85 deg. DB             | Low Side  | 80  | 82  | 84  | 86  | 88  | 90  | 92  | 93  | 95  |
|                                 | 72 deg. WB             | High Side | 184 | 200 | 217 | 234 | 252 | 270 | 289 | 308 | 327 |
| BC36B<br>Rated<br>CFM<br>1200   | 75 deg. DB             | Low Side  | 66  | 67  | 69  | 70  | 72  | 74  | 75  | 77  | 78  |
|                                 | 62 deg. WB             | High Side | 168 | 184 | 199 | 215 | 230 | 245 | 261 | 276 | 292 |
|                                 | 80 deg. DB             | Low Side  | 71  | 72  | 74  | 75  | 77  | 79  | 80  | 82  | 83  |
|                                 | 67 deg. WB             | High Side | 173 | 189 | 204 | 220 | 236 | 252 | 268 | 283 | 299 |
| BC36B<br>Rated<br>CFM<br>1200   | 85 deg. DB             | Low Side  | 76  | 77  | 79  | 80  | 82  | 84  | 85  | 87  | 88  |
|                                 | 72 deg. WB             | High Side | 178 | 194 | 211 | 227 | 244 | 261 | 277 | 294 | 310 |

## COOLING

Air Temperature Entering Outdoor Coil Degree F

| Model                           | Return Air Temperature | Pressure  | °   | °   | °   | °   | °   | °   | °   | °   | °   |
|---------------------------------|------------------------|-----------|-----|-----|-----|-----|-----|-----|-----|-----|-----|
|                                 |                        |           | 75  | 80  | 85  | 90  | 95  | 100 | 105 | 110 | 115 |
| A48AS-A<br>Rated<br>CFM<br>1325 | 75 deg. DB             | Low Side  | 65  | 67  | 69  | 71  | 73  | 75  | 76  | 78  | 79  |
|                                 | 62 deg. WB             | High Side | 159 | 174 | 189 | 205 | 221 | 237 | 254 | 271 | 289 |
|                                 | 80 deg. DB             | Low Side  | 70  | 72  | 74  | 76  | 78  | 80  | 82  | 83  | 85  |
|                                 | 67 deg. WB             | High Side | 163 | 179 | 194 | 211 | 227 | 244 | 261 | 278 | 296 |
| BC36B<br>Rated<br>CFM<br>1240   | 85 deg. DB             | Low Side  | 74  | 77  | 79  | 82  | 84  | 86  | 88  | 90  | 91  |
|                                 | 72 deg. WB             | High Side | 168 | 184 | 201 | 218 | 235 | 252 | 270 | 288 | 306 |
|                                 | 75 deg. DB             | Low Side  | 61  | 64  | 66  | 68  | 70  | 71  | 72  | 73  | 73  |
|                                 | 62 deg. WB             | High Side | 156 | 170 | 185 | 200 | 216 | 232 | 249 | 266 | 283 |
| BC36B<br>Rated<br>CFM<br>1240   | 80 deg. DB             | Low Side  | 66  | 69  | 71  | 73  | 75  | 76  | 77  | 78  | 78  |
|                                 | 67 deg. WB             | High Side | 160 | 175 | 190 | 206 | 222 | 239 | 256 | 273 | 291 |
|                                 | 85 deg. DB             | Low Side  | 70  | 74  | 77  | 79  | 81  | 82  | 83  | 84  | 84  |
|                                 | 72 deg. WB             | High Side | 165 | 181 | 197 | 213 | 230 | 247 | 265 | 283 | 301 |

Low side pressure  $\pm$  2 PSIG (suction line @ outdoor unit base valve)High side pressure  $\pm$  5 PSIG (liquid line @ outdoor unit base valve)

Tables are based upon rated CFM (airflow) across the evaporator coil and should be found under section titled "Refrigerant Charge" elsewhere in manual. If there is any doubt as to correct operating charge being in the system, the charge should be removed, system evacuated, and recharged to serial plate instructions.



## 4812UACSB

TABLE 18

| COOLING                         |                        |           | Air Temperature Entering Outdoor Coil Degree F |     |     |     |     |     |     |     |     |
|---------------------------------|------------------------|-----------|--|-----|-----|-----|-----|-----|-----|-----|-----|
| Model                           | Return Air Temperature | Pressure  | °  | °   | °   | °   | °   | °   | °   | °   | °   |
|                                 |                        |           | 75   | 80  | 85  | 90  | 95  | 100 | 105 | 110 | 115 |
| A61XS-A<br>Rated<br>CFM<br>1600 | 75 deg. DB             | Low Side  | 75   | 76  | 76  | 77  | 78  | 79  | 80  | 82  | 83  |
|                                 | 62 deg. WB             | High Side | 168  | 181 | 196 | 211 | 227 | 244 | 262 | 280 | 300 |
|                                 | 80 deg. DB             | Low Side  | 79   | 81  | 82  | 83  | 84  | 85  | 86  | 88  | 89  |
|                                 | 67 deg. WB             | High Side | 172  | 186 | 201 | 217 | 233 | 250 | 268 | 287 | 307 |
|                                 | 85 deg. DB             | Low Side  | 86   | 87  | 88  | 89  | 90  | 91  | 93  | 94  | 96  |
|                                 | 72 deg. WB             | High Side | 179  | 193 | 208 | 224 | 241 | 259 | 278 | 297 | 318 |
|                                 | 75 deg. DB             | Low Side  | 76   | 77  | 79  | 80  | 81  | 82  | 83  | 83  | 84  |
|                                 | 62 deg. WB             | High Side | 165  | 179 | 194 | 210 | 226 | 243 | 261 | 279 | 298 |
| BC60BX<br>Rated<br>CFM<br>1600  | 80 deg. DB             | Low Side  | 82   | 83  | 85  | 86  | 87  | 88  | 89  | 89  | 90  |
|                                 | 67 deg. WB             | High Side | 169  | 184 | 199 | 215 | 232 | 249 | 268 | 286 | 306 |
|                                 | 85 deg. DB             | Low Side  | 87   | 89  | 91  | 93  | 94  | 85  | 96  | 97  | 97  |
|                                 | 72 deg. WB             | High Side | 176  | 191 | 206 | 223 | 240 | 258 | 277 | 297 | 317 |

## 6012UACSB

TABLE 19

| COOLING                         |                        |           | Air Temperature Entering Outdoor Coil Degree F |     |     |     |     |     |     |     |     |
|---------------------------------|------------------------|-----------|--|-----|-----|-----|-----|-----|-----|-----|-----|
| Model                           | Return Air Temperature | Pressure  | °  | °   | °   | °   | °   | °   | °   | °   | °   |
|                                 |                        |           | 75   | 80  | 85  | 90  | 95  | 100 | 105 | 110 | 115 |
| A61XS-A<br>Rated<br>CFM<br>1780 | 75 deg. DB             | Low Side  | 75   | 76  | 76  | 77  | 78  | 79  | 80  | 80  | 81  |
|                                 | 62 deg. WB             | High Side | 177  | 193 | 209 | 226 | 243 | 261 | 280 | 299 | 319 |
|                                 | 80 deg. DB             | Low Side  | 80   | 81  | 81  | 82  | 83  | 84  | 85  | 86  | 87  |
|                                 | 67 deg. WB             | High Side | 183  | 199 | 215 | 231 | 249 | 267 | 286 | 306 | 327 |
|                                 | 85 deg. DB             | Low Side  | 86   | 87  | 87  | 88  | 89  | 90  | 91  | 93  | 94  |
|                                 | 72 deg. WB             | High Side | 189  | 205 | 222 | 240 | 258 | 277 | 297 | 317 | 338 |
|                                 | 75 deg. DB             | Low Side  | 75   | 76  | 76  | 77  | 78  | 79  | 80  | 80  | 81  |
|                                 | 62 deg. WB             | High Side | 177  | 192 | 207 | 224 | 241 | 259 | 278 | 298 | 318 |
| BC60BX<br>Rated<br>CFM<br>1800  | 80 deg. DB             | Low Side  | 79   | 80  | 82  | 83  | 84  | 85  | 86  | 86  | 87  |
|                                 | 67 deg. WB             | High Side | 182  | 197 | 213 | 229 | 247 | 265 | 285 | 305 | 326 |
|                                 | 85 deg. DB             | Low Side  | 85   | 87  | 88  | 89  | 90  | 91  | 92  | 93  | 94  |
|                                 | 72 deg. WB             | High Side | 187  | 203 | 220 | 238 | 256 | 275 | 295 | 316 | 337 |

Low side pressure + 2 PSIG (suction line @ outdoor unit base valve)

High side pressure + 5 PSIG (liquid line @ outdoor unit base valve)

Tables are based upon rated CFM (airflow) across the evaporator coil and should be found under section titled "Refrigerant Charge" elsewhere in manual. If there is any doubt as to correct operating charge being in the system, the charge should be removed, system evacuated, and recharged to serial plate instructions.