

INSTALLATION INSTRUCTIONS

HIGH EFFICIENCY WATER SOURCE SPLIT HEAT PUMP SYSTEMS

MODELS

WQS30A

WQS36A

WQS42A

**Ground Water
Temperatures 45° - 75° F**

**Earth Loop Fluid
Temperatures 25° - 110° F**

DATE: 06/01/95

MANUAL 2100-170 F
SUPERSEDES REV. E
FILE VOL. I, TAB 8

TABLE OF CONTENTS

I.	Application and Location.	5
	General	5
	Shipping Damage	5
	Application	5
	Location	5
	Indoor Coil	5
	Important Installer Note	6
	Piping Access to the Unit	6
	Water Connections for Well Applications	6
	Well Pump Sizing	8
II.	Lake and Pond Installations	9
III.	Earth Coupled Ground Loop Applications	10
IV.	Field Installed Ad-On Heat Recovery Hot Water Heater	10
	General	10
	Installation	11
	Start-Up, Check-Out Maintenance	13
	Heat Pump Service	14
	Installing Refrigerant Tubing	14
	Precharged Tubing Connections: Quick Connect Indoor Unit and . . .	15
	Quick Connect Outdoor Unit	
	Field Fabricated Tubing Connections: Sweat Indoor Unit and . . .	17
	Quick Connect Outdoor Unit Using CTO Kit	
V.	Wiring Instructions	19
	General	19
	Discharge Temperature Sensor	19
VI.	Sequence of Operation--WQS with Fossil Fuel Furnace	20
	1. First Stage Heating	20
	2. Second Stage Starts Gas Burner (Or Oil Burner)	20
	3. First Stage Keeps Gas Burner Operating (Or Oil Burner)	20
	4. Cooling	21
	5. Check Light	21
	Thermostat Indicator Lamps	22
	Compressor Short Cycle Protection	22
	Emergency Heat Position	22
VII.	Charging Instructions	22
	Pressure Service Ports	22
	Refrigerant Charge	22
	Total System Charge for Split Systems	23
	A. Application Guidelines	24
	Final Check List	24
VIII.	System Start Up Procedure	25
IX.	Service	26
	Service Hints	26
X.	Water Corrosion	26
XI.	Remedies of Water Problems	27
	A. Water Treatment	27
	B. Acid Cleaning The Water Coil Or Heat Recovery Unit	27
XII.	Quick Reference Troubleshooting Chart For Water To Air Heat Pump.	28
XIII.	Pressure Curves	29
XIV.	Wiring Diagrams	32
XV.	Performance Check--Water Source Heat Pumps.	37

FIGURES AND TABLES

Figure 1	1
Figure 2	7
Figure 3	9
Figure 4	11
Figure 5A.	12
Figure 5B.	12
Figure 6A.	13
Figure 6B.	13
Figure 7	14
Figure 9	15
Figure 10.	19
Figure 11.	19
Figure 12.	27

Table 1	1
Table 2	2
Table 3	2
Table 4	3
Table 5	3
Table 6	4
Table 7	4
Table 8	6
Table 9	15
Table 10	19
Table 11	19
Table 12	22
Table 13	23
Table 14	23
Table 15	24
Table 16	24
Table 17	29
Table 18	29
Table 19	30
Table 20	30
Table 21	31
Table 22	31

FIGURE 1

NOMENCLATURE EXPLANATION--EXAMPLE:

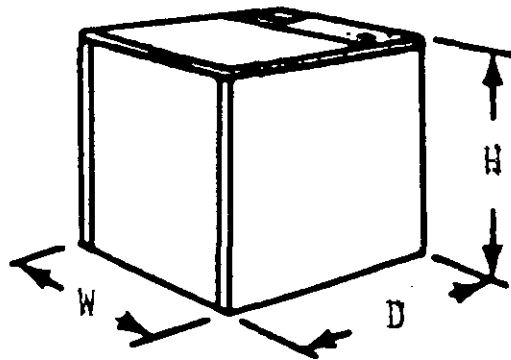
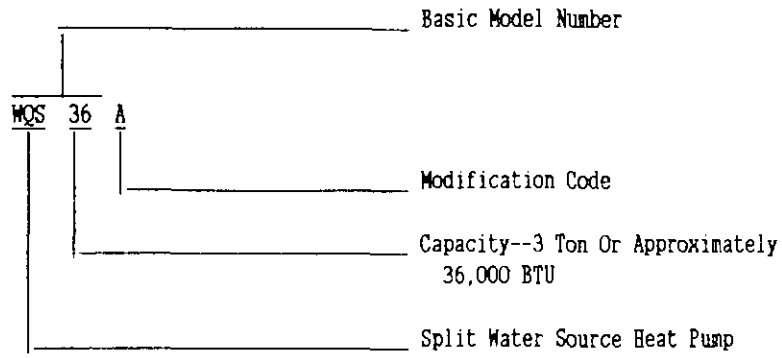

TABLE 1

DIMENSIONS			
Basic Model No.	"W" Width	"D" Depth	"H" Height
WQS30A WQS36A	18"	23-1/2"	24"
WQS42A	22"	28"	24"

TABLE 2 SPECIFICATIONS

MODEL	WQS30A	WQS36A	WQS42A
ELECTRICAL RATING (60HZ/V/PH)	230/208-1	230/208-1	230/208-1
Operating Voltage Range	197-253	197-253	197-253
Minimum Circuit Ampacity	18	23	32
+Field Wire Size	#12	#10	#10
++Delay Fuse Maximum or Ckt. Bkr.	30	40	55
Total Unit Amps 230/208	12.65/13.95	14.4/16.65	20.0/24.5
COMPRESSOR			
Volts	230/208	230/208	230/208
Rated Load Amps 230/208	12.65/13.95	14.4/16.65	20.0/24.5
Branch Ckt. Selection Current	13.9	18.0	25.0
Lock Rotor Amps 230/208	76/76	90.5/90.5	107/107
CONDENSER			
Coaxial-Water	Cupro-Nickel	Cupro-Nickel	Cupro-Nickel
Water Connections	3/4" FPT	3/4" FPT	3/4" FPT
Refrigerant Connection and Charge			
Suction Line Fitting	-10	-10	-12
Liquid Line Fitting	-6	-6	-6
Factory Charge R-22 Oz.	51 oz.	56.5 oz.	88.5 oz.
Shipping Weight lbs.	135	150	210

TABLE 3 RATED CFM, GPM AND AIR FLOW DATA (WET COIL--COOLING)

Compressor Section Model Number	GPM	Evaporator Coil Model Number	Rated Airflow		Rated E.S.P. (2)	Motor Speed Tap	Recommended Airflow Range	System Orifice Required
			CFM	Pressure Drop H2O (1)				
WQS30A	5	A36AQ-A	1100	.20			850 - 1200	.067
WQS30A	5	BC24B	875		.15	High	650 - 940	.069*
WQS36A	5	A36AQ-A	1200	.25			950 - 1300	.067
WQS36A	5	BC36B	1150		.20	High	900 - 1250	.067*
WQS42A	6	A42AQ-A	1450	.20			1100 - 1600	.078
WQS42A	6	BC36B	1150		.20	High	900 - 1250	.076*

(1) Measured across the evaporator coil assembly, including drain pan.

(2) External static pressure available for the duct system--supply and return. All blower coils have multi-speed motors, and value shown is at the recommended rated speed. Consult specification airflow charts with the blower coil units for complete information at other speeds.

***IMPORTANT**

Proper sized orifice is not factory installed in the indoor section. Proper orifice size is shipped with compressor unit packaged with its installation instructions. The orifice must be replaced with the proper system orifice shown above in Table 3.

Flow rate required GPM water	5	6
Flow rate required GPM 15% propylene glycol	6.5	7.8
Flow rate required GPM 30% propylene glycol	8.0	9.6

TABLE 4 CONSTANT FLOW VALVES

Part No.	Min. Available Pressure PSIG	Flow Rate GPM
8603-011	15*	5
8603-007	15*	6

*The pressure drop through the constant flow valve will vary depending on the available pressure ahead of the valve. Unless a minimum of 15 psig is available immediately ahead of the valve, no water will flow.

TABLE 5 WATER COIL PRESSURE DROP

Model	WQS30A		WQS36A		WQS42A	
	GPM	Psig	Ft. Hd	Psig	Ft. Hd	Psig
4	2.0	4.6	1.9	4.4	--	--
5	3.0	6.9	2.0	4.6	--	--
6	4.2	10.0	2.4	5.5	2.5	5.8
7	5.7	13.1	3.0	6.9	3.2	7.4
8	7.5	17.3	3.9	9.0	4.0	9.2
9	9.5	21.9	5.5	12.7	5.2	12.0
10	12.0	27.7	7.6	17.5	6.5	15.0
11	14.8	34.1	10.4	24.0	7.7	17.8
12	17.6	40.6	15.3	35.3	9.0	20.8
13	20.3	46.8	20.6	47.5	10.5	24.2

TABLE 6 MAXIMUM E.S.P. OPERATION INFORMATION (1) MODEL BC24B

Compressor Section/ Type of Application	Upflow Blower Speed			Horizontal Blower Speed			(2) Counterflow Blower Speed			Control Circuit Connection Diagram
	Low	Med	High	Low	Med	High	Low	Med	High	
MQS30A w/ 9KW	N/A	N/A	.30	N/A	N/A	.35	N/A	N/A	.35	4091-410(3)
MQS30A w/ 5KW	N/A	N/A	.30	N/A	N/A	.35	N/A	N/A	.35	4091-406
MQS30A w/ 0KW	.60	.60	.60	.60	.60	.60	.60	.60	.60	4091-405
9KW Only	.60	.60	.60	.60	.60	.60	.60	.60	.60	4091-407
5KW Only	.60	.60	.60	.60	.60	.60	.60	.60	.60	4091-407

(1) Values shown are for bottom and side return opening
 (2) Side inlet not available on counterflow applications
 (3) Control circuit diagram allows only operation of heat pump and 5KW. Second stage 5KW can only be used as emergency heat.

TABLE 7 MAXIMUM E.S.P. OPERATION INFORMATION (1) MODEL BC36B

Compressor Section/ Type of Application	Upflow Blower Spd		Horizontal Blower Spd		(2) Counterflow Blower Spd		Control Circuit Connection Diagram
	Low	High	Low	High	Low	High	
MQS36A w/ 18KW	.25	.40	.25	.35	.25	.35	4091-408
MQS36A w/ 14KW	.35	.50	.35	.45	.30	.40	4091-408
MQS36A w/ 9KW	.45	.60	.45	.55	.40	.50	4091-406
MQS36A w/ 5KW	.60	.60	.55	.60	.50	.60	4091-406
MQS36A w/ 0KW	.60	.60	.60	.60	.60	.60	4091-405
MQS42A w/ 18KW	N/A	.30	N/A	.30	N/A	.30	4091-410(3)
MQS42A w/ 14KW	.30	.40	.30	.40	.30	.40	4091-410(3)
MQS42A w/ 9KW	N/A	.30	N/A	.30	N/A	.30	4091-406
MQS42A w/ 5KW	.30	.40	.30	.40	.30	.40	4091-406
MQS42A w/ 0KW	.60	.60	.60	.60	.60	.60	4091-405
18KW Only	.60	.60	.60	.60	.60	.60	4091-409
14KW Only	.60	.60	.60	.60	.60	.60	4091-409
9KW Only	.60	.60	.60	.60	.60	.60	4091-407
5KW Only	.60	.60	.60	.60	.60	.60	4091-407

(1) Values shown are for bottom and side return opening
 (2) Side inlet not available on counterflow applications
 (3) Control circuit diagram allows only operation of heat pump and 9kw. Second stage 5 or 9KW can only be used as emergency heat

I. APPLICATION AND LOCATION

GENERAL

These instructions explain the recommended method to install the water source heat pump unit, the interconnecting refrigerant tubing and the electrical wiring connections to the unit.

The units are to be used in conjunction with the matching indoor coils or indoor blower coil for comfort cooling/heating applications as shown in the specification sheet.

These instructions and any instructions packaged with any separate equipment required to make up the entire system should be carefully read before beginning the installation. Note particularly "Connecting Quick-Connect Couplings, Starting Procedure" and any tags and/or labels attached to the equipment.

While these instructions are intended as a general recommended guide, they do not supersede any national and/or local codes in any way. Authorities having jurisdiction should be consulted before the installation is made.

SHIPPING DAMAGE

Upon receipt of equipment, the carton should be checked for external signs of shipping damage. If damage is found, the receiving party must contact the last carrier immediately, preferably in writing, requesting inspection by the carrier's agent.

APPLICATION

Size of unit for a proposed installation should be based on heat loss calculation made according to methods of Air Conditioning Contractors of America. The air duct should be installed in accordance with the Standards of the National Fire Protection Association for the Installation of Air Conditioning and Ventilating Systems of Other Than Residence Type, NFPA No. 90A and Residence Type Warm Air Heating and Air Conditioning Systems, NFPA No. 90B. Where local regulations are at a variance with instructions, installer should adhere to local codes.

LOCATION

The unit may be installed in a basement, closet or utility room provided adequate service access is insured. Ideally, three sides of the unit should have a minimum access clearance of two feet but the unit can be adequately serviced if two or only one side has the minimum two feet clearance. The unit must be located in the conditioned space to prevent freezing of the water lines and to permit proper automatic shut off of the water regulating valves. See water piping section.

Clearance to combustible materials is 0 inches for the compressor section of the heat pump. See instructions for the indoor section for its clearance requirements.

Before setting the unit, consider ease of piping, drain and electrical connections for the unit. Also, for units used with optional heat recovery unit, consider the proximity of the unit to the water heater or storage tank. Place the unit on a solid base, preferably concrete to minimize undesirable noise and vibration. DO NOT elevate the base pan or rubber or cork vibration eliminator pads as this will permit the unit base to act like a drum.

INDOOR COIL

These units are designed to match with all indoor blower coils and "A" coils shown earlier in these instructions. All "A" coils and blower coils shown are produced with an interchangeable brass orifice to provide optimum matching of the refrigerant control when matching alternate sized indoor units to the compressor unit. A properly sized orifice for each compressor section is packaged with this unit. See installation instructions packaged with the indoor section for complete details on how to change the orifice when required. See Table 3 for proper system orifice required.

IMPORTANT INSTALLER NOTE

For improved start-up performance, wash the indoor coil with a dishwasher detergent.

PIPING ACCESS TO THE UNIT

Water piping to and from the unit enters the top of the unit casing through the water access panel. Piping connections are made directly to the heat exchanger coil and are 3/4 inch FPT for all models.

WATER CONNECTIONS FOR WELL APPLICATIONS

It is very important that an adequate supply of clean, non-corrosive water at the proper pressure be provided before the installation is made. Insufficient water, in the heating mode for example, will cause the low pressure control to trip, shutting down the heat pump. In assessing the capacity of the water system, it is advisable that the complete water system be evaluated to prevent possible lack of water or water pressure at various household fixtures whenever the heat pump turns on. All plumbing to and from the unit is to be installed in accordance with local plumbing codes. The use of plastic pipe, where permissible, is recommended to prevent electrolytic corrosion of the water pipe. Because of the relatively cold temperatures encountered with well water, it is strongly recommended that the water lines connecting the unit be insulated to prevent water droplets from condensing on the pipe surface.

Refer to Piping, Figure 2. Slow closing solenoid valve (6) with a 24V coil provides on/off control of the water flow to the unit. Refer to the wiring diagram for correct hookup of the valve solenoid coil.

Constant Flow Valve (7) provides correct flow of water to the unit regardless of variations in water pressure. Observe the water flow direction indicated by the arrow on the side of the valve body. Following is a table showing which valve is to be installed with which heat pump.

TABLE 8 CONSTANT FLOW VALVE

Heat Pump Model	Flow Rate	Part Number
WQS30A WQS36A	5 GPM	8603-011
WQS42A	6 GPM	8603-007

FIGURE 2

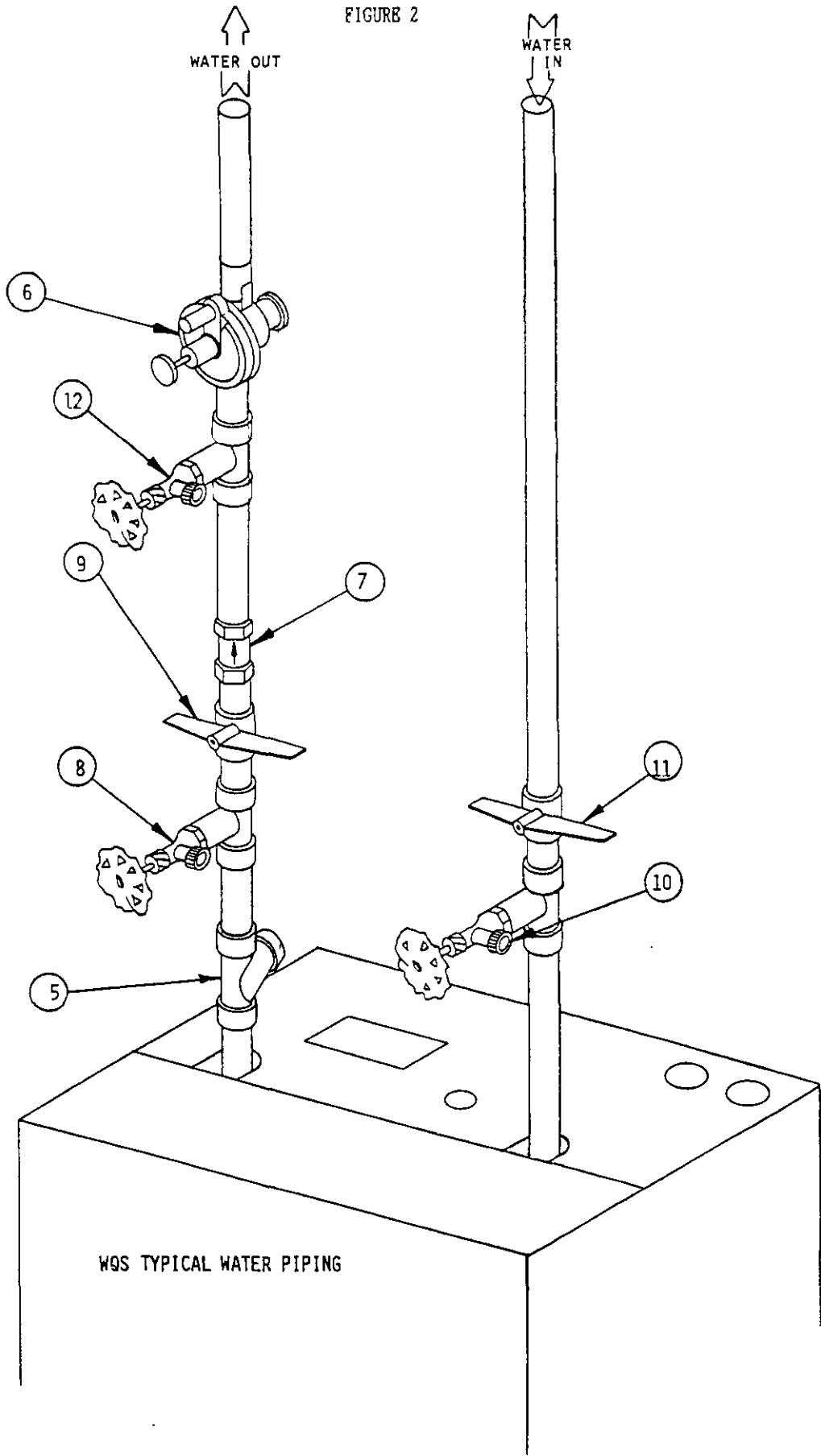

WQS TYPICAL WATER PIPING

Strainer (5) installed upstream of constant flow valve (7) to collect foreign material which would clog the flow valve orifice.

The figure shows the use of shut-off valves (9) and (11), on the in and out water lines to permit isolation of the unit from the plumbing system should future service work require this. Globe valves should not be used as shutoff valves because of the excessive pressure drop inherent in the valve design. Instead use gate or ball valves as shutoffs so as to minimize pressure drop.

Drain cocks (8) and (10), and tees have been included to permit acid cleaning the refrigerant-to-water coil should such cleaning be required. See WATER CORROSION.

Drain Cocks (12) provide access to the system to check water flow through the constant flow valve to insure adequate water flow through the unit. A water meter 1-10 GPM (8603-013) is used to check the water flow rate.

WELL PUMP SIZING

Strictly speaking, sizing the well pump is the responsibility of the well drilling contractor. It is important, however, that the HVAC contractor be familiar with the factors that determine what size pump will be required. Rule of thumb estimates will invariably lead to under or oversized well pumps. Undersizing the pump will result in inadequate water to the whole plumbing system but with especially bad results to the heat pump--NO HEAT/NO COOL calls will result. Oversized pumps will short cycle and could cause premature pump motor or switch failure.

The well pump must be capable of supplying enough water and at an adequate pressure to meet competing demands of water fixtures. The well pump must be sized in such a way that three requirements are met:

1. Adequate flow rate in GPM.
2. Adequate pressure at the fixtures.
3. Able to meet the above from the depth of the well-feet of lift.

The pressure requirements put on the pump are directly affected by the diameter of the pipe being used as well as by the water flow rate through the pipe. The worksheet included in Manual 2100-078 should guarantee that the well pump has enough capacity. It should also insure that the piping is not undersized which would create too much pressure loss due to friction loss. High pressure losses due to undersized pipe will reduce efficiency and require larger pumps and could also create water noise problems.

II. LAKE AND POND INSTALLATIONS

Lakes and ponds can provide a low cost source of water for heating and cooling with a ground water heat pump. Direct usage of the water without some filtration is not recommended as algae and turbid water can foul the water to Freon heat exchanger. Instead, there have been very good results using a dry well dug next to the water line or edge. Normal procedure in installing a dry well is to backhoe a 15 to 20 foot hole adjacent to the body of water (set backhoe as close to the water's edge as possible). Once excavated, a perforated plastic casing should be installed with gravel backfill placed around the casing. The gravel bed should provide adequate filtration of the water to allow good performance of the ground water heat pump.

FIGURE 3

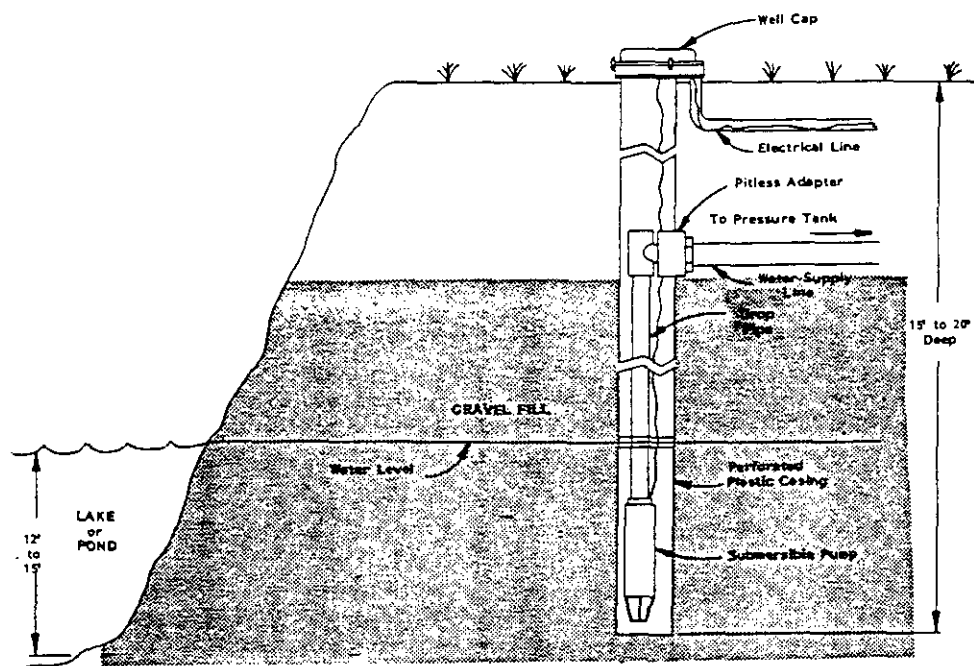

The following is a list of recommendations to follow when installing this type of system:

- A. A lake or pond should be at least 1 acre (40,000 square feet) in surface area for each 50,000 BTUs of ground water heat pump capacity or have 2 times the cubic feet size of the dwelling that you are trying to heat (includes basement if heated).
- B. The average water depth should be at least 5 feet and there should be an area where the water depth is at least 12 to 15 feet deep.
- C. If possible, use a submersible pump suspended in the dry well casing. Jet pumps and other types of suction pumps normally consume more electrical energy than similarly sized submersible pumps. Pipe the unit the same as a water well system.
- D. Size the pump to provide necessary GPM for the ground water heat pump. A 12 GPM or greater water flow rate is required on all modes when used on this type system.
- E. A pressure tank should be installed in the dwelling to be heated adjacent to the ground water heat pump. A pressure switch should be installed at the tank for pump control.
- F. All plumbing should be carefully sized to compensate for friction losses, etc., particularly if the pond or lake is over 200 feet from the dwelling to be heated or cooled.

- G. Keep all water lines below low water level and below the frost line.
- H. Most installers use 4-inch field tile (rigid plastic or corrugated) for water return to the lake or pond.
- I. The drain line discharge should be located at least 100 feet from the dry well location.
- J. The drain line should be installed with a slope of 2 inches per 10 feet of run to provide complete drainage of the line when the ground water heat pump is not operating. This gradient should also help prevent freezing of the discharge where the pipe terminates above the frost line.
- K. Locate the discharge high enough above high water level so the water will not back up and freeze inside the drain pipe.
- L. Where the local conditions prevent the use of a gravity drainage system to a lake or pond, you can instead run standard plastic piping out into the pond below the frost and low water level.

<p>WARNING</p> <p>THIN ICE MAY RESULT IN THE VICINITY OF THE DISCHARGE LINE.</p>

For complete information on water well systems and lake and pond applications, refer to Manual 2100-078 available from your distributor.

III. EARTH COUPLED GROUND LOOP APPLICATIONS

This unit is also designed to work on earth coupled ground loop systems, however, these systems operate at entering water (without antifreeze) temperature well below the temperature normally experienced in water well system. Therefore, when this unit is connected to an earth coupled ground loop, an optional thermostat kit, 8620-002, is required. The kit consists of a SPST thermostat to sense refrigerant temperature and shut off compressor should extremely low antifreeze temperatures or loss of flow occur. See Installation Instructions for thermostat kit packed with the thermostat.

When used on these systems, Item 5 strainer, Item 6 solenoid valve, and Item 7 constant flow valve (refer to Figure 2) are not needed. An external circulating pump must be used.

For information on earth coupled loop design, piping connections to heat pump and installation refer to Manual 2100-099, "Earth Coupled Loop System Design Manual," available from your distributor.

IV. FIELD INSTALLED ADD-ON HEAT RECOVERY HOT WATER HEATER

NOTE: This section applies only if a water heating recovery device is added.

GENERAL

This high efficiency water source heat pump series was designed for easy field installation of a heat recovery device for water heating commonly known as a desuperheater water heater. The amount of annual hot water supplied and thus additional energy cost savings will depend on the amount of hot water your family uses and the number of hours your heat pump operates. We recommend that a U.L. recognized heat recovery device be used. This device must be suitable for potable water.

INSTALLATION

1. Follow all local, state and national codes applicable to the installation of heat recovery devices.
2. Follow the installation procedures you receive with the heat recovery device.
3. Connect the refrigerant lines between the heat recovery device and the heat recovery valves in the heat pump using the tubing in the upper right corner of the unit as shown in Figure 4. Keep dirt and moisture out of the inter-connecting tubing using good refrigeration service procedures. (See Figure 4). Use refrigeration grade (type L) copper tubing. The tube diameter should be the same as the valve for lengths up to 15 feet each way. For lengths between 15 and 25 feet, increase the diameter 1/8". Avoid placing the heat recovery device over 25 feet from the heat pump.

This tubing should be insulated with Armaflex insulation. Tubing should be protected from abrasion and damage.

FIGURE 4
CONNECTIONS FOR FIELD INSTALLED WATER HEATER

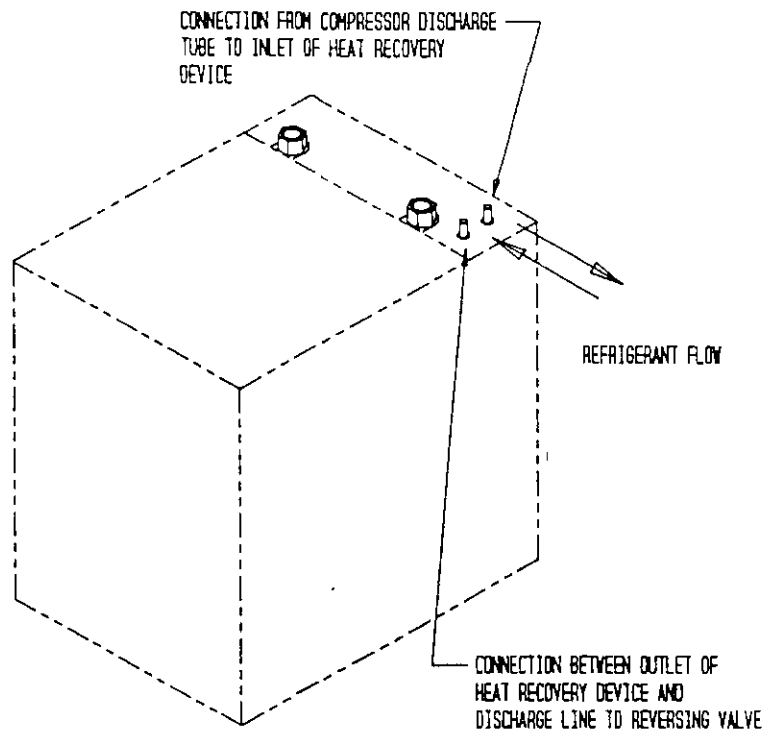

4. Evacuate the heat recovery device inter-connecting tubing and heat exchanger through the process service ports A or B shown in Figure 5A and pressurize with Refrigerant 22 and perform a leak check. Release the charge used for pressurization, leak check and re-evacuate. Add 1 ounce of refrigerant for each 10 feet of additional interconnecting tubing to the total system charge. Replace the caps and tighten.

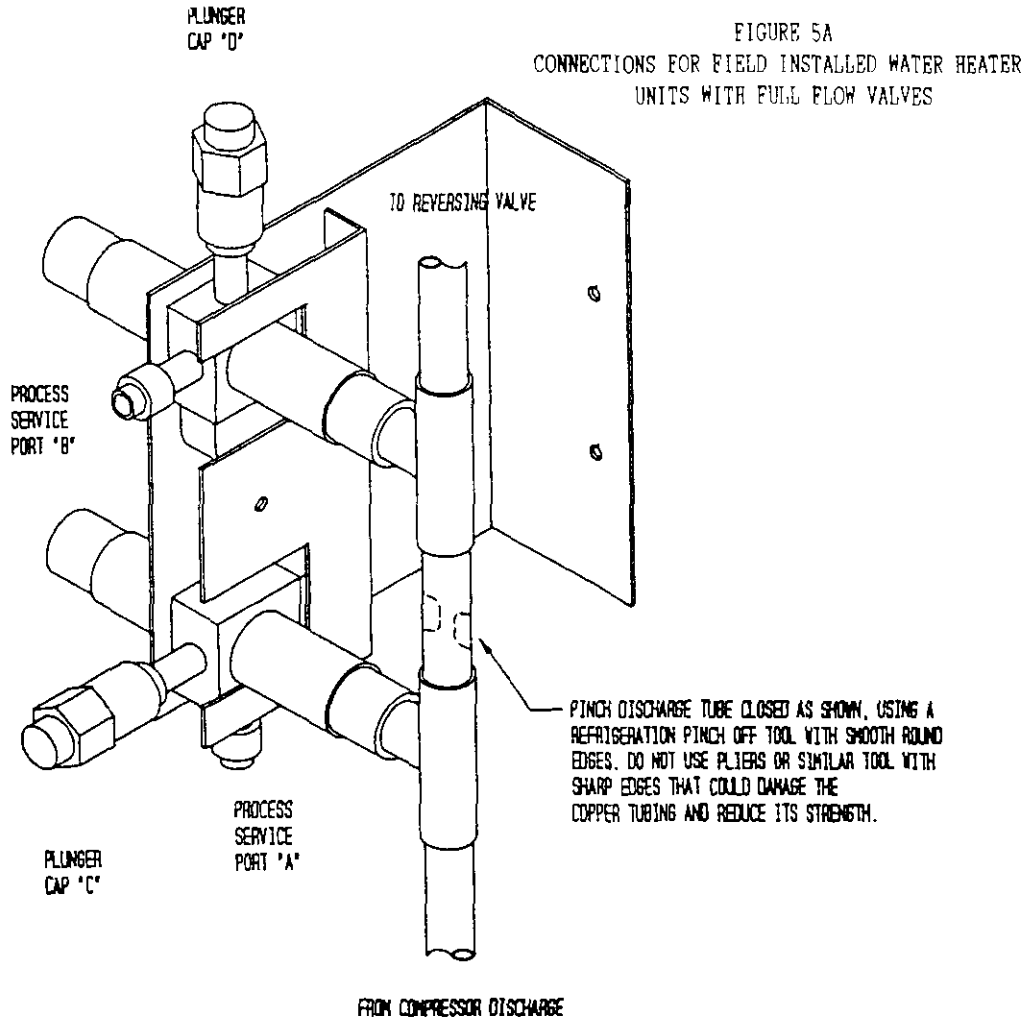
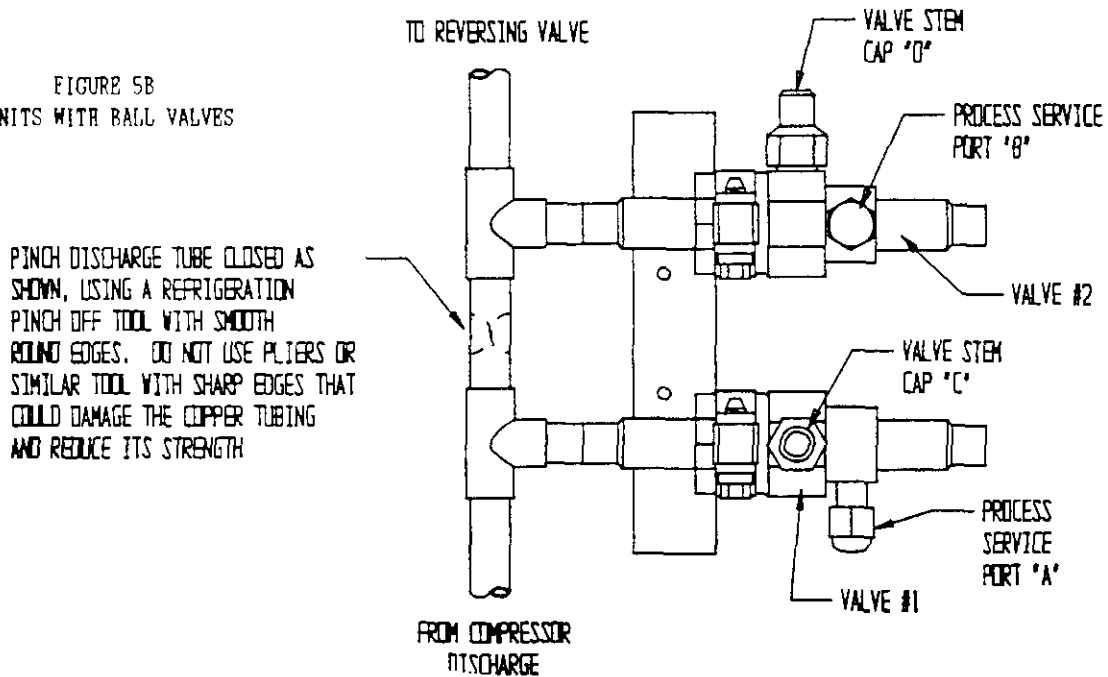

FIGURE 5B
UNITS WITH BALL VALVES



UNITS WITH FULL FLOW VALVES

5. Tighten the plunger caps "C" and "D" shown in Figure 5A. This forces down a plunger which shears a frangible plug and moves it out of the refrigerant flow path (see Figure 6A). This now permits the discharge refrigerant from the compressor to flow through valve at plunger "C" (Figure 5A) to the heat recovery coil heat exchanger and back through the valve at plunger "D" and then to the condenser inlet.

FIGURE 6A

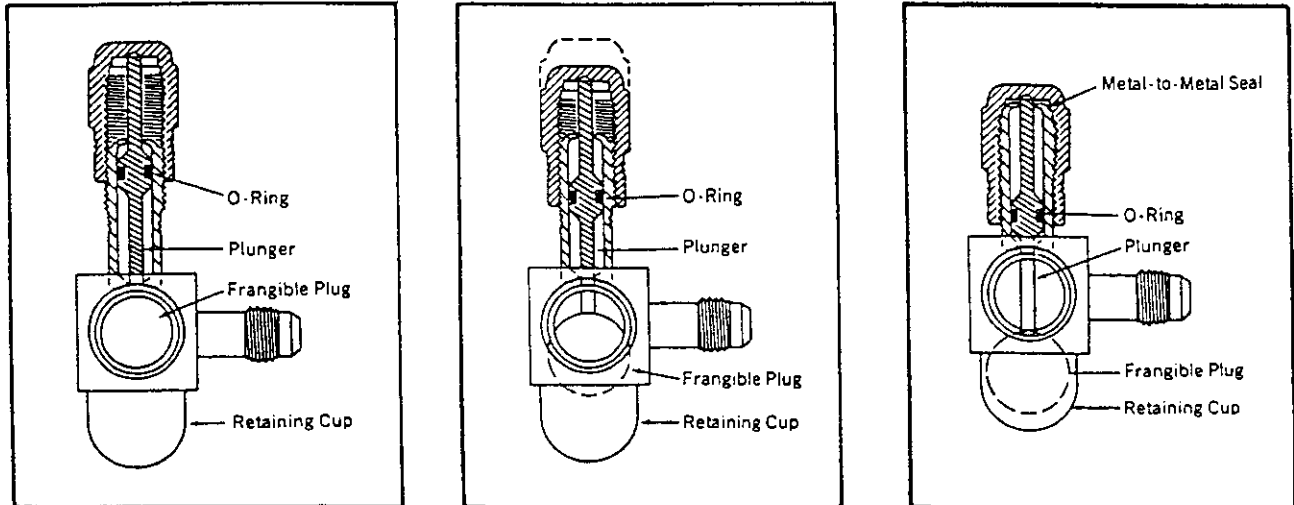

When the plunger cap is tightened, the plunger shears the frangible plug forcing it into the retaining cup. This opens the valve for refrigerant flow.

The O-Ring seal on the plunger prevents leakage while the valve is being opened.

Tightening the plunger cap 1/4 turn after it bottoms results in a metal-to-metal seal.

UNITS WITH BALL VALVES

5. Remove valve stem caps "C" and "D" shown in Figures 5B and 6B. Turn the valve stems one-quarter turn counterclockwise (see Figure 6B). This now permits the discharge refrigerant from the compressor to flow through valve No. 1 to the heat recovery coil heat exchanger and back through valve No. 2 and then to the condenser inlet. Replace the valve stem cap and finger tighten. Then tighten an additional 1/4 turn. A metal to metal seal is now complete. (See Figure 6B)

FIGURE 6B

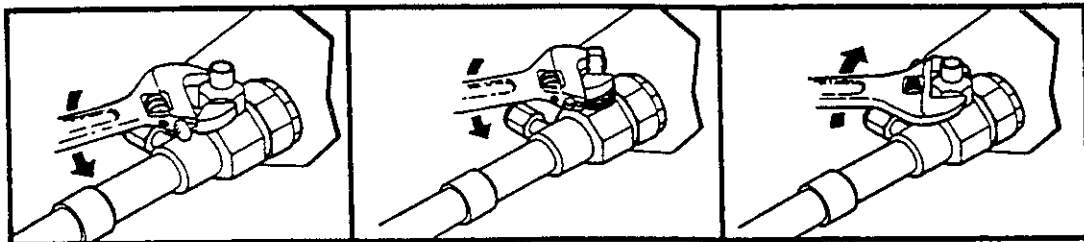

6. Wire the heat recovery device per the diagram supplied with the heat recovery unit. Turn power to the air conditioner off prior to wiring the heat recovery unit. DO NOT in any way alter any factory or safety circuits on the air conditioner.

START-UP, CHECK-OUT MAINTENANCE

Follow the procedures supplied with the heat recovery unit.

HEAT PUMP SERVICE

While performing any heat pump service analysis, turn water pump switch to off as it could affect the refrigerant pressures and be misleading.

FIGURE 7

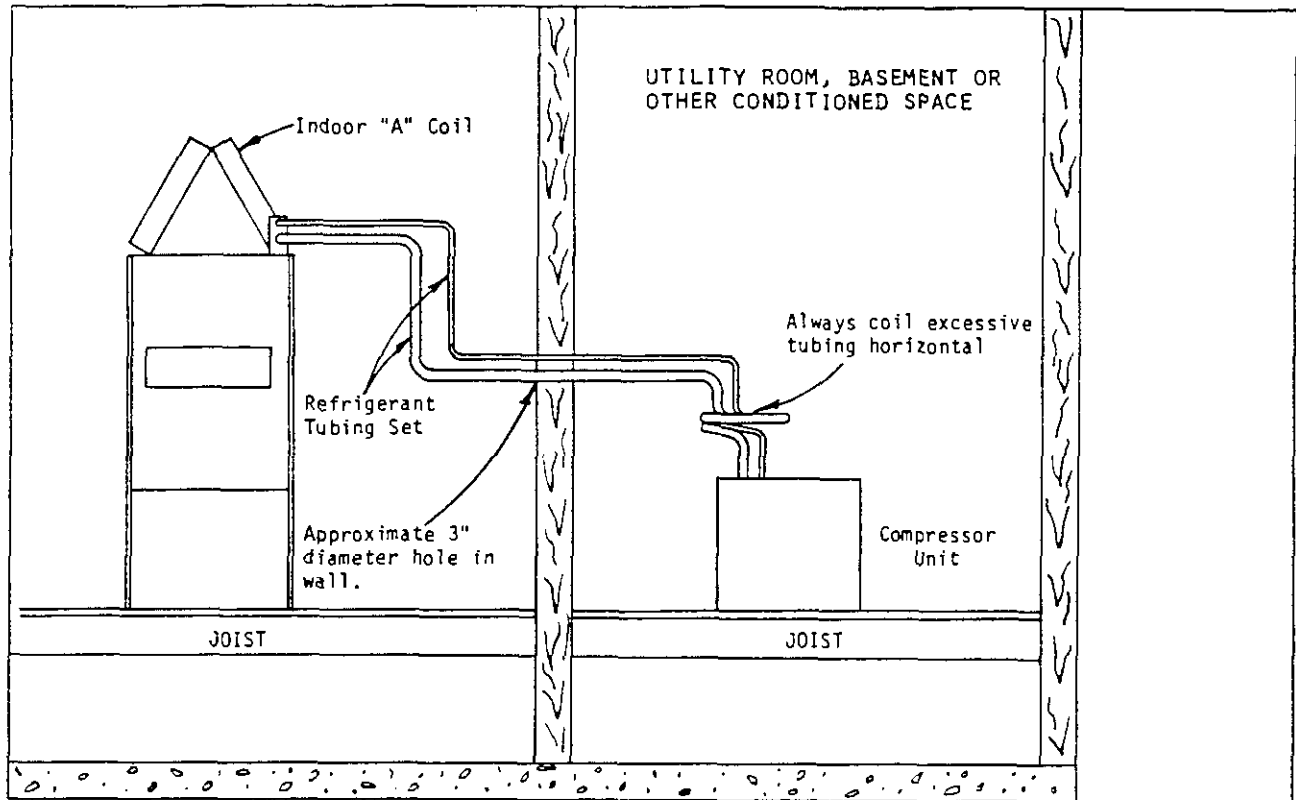

INSTALLING REFRIGERANT TUBING

The information that follows on installing refrigerant tubing and for changing the system orifice (if required) covers applications listed in the front of this installation instruction only. Although other indoor units may be of similar construction, the installation instructions for these units should be consulted for proper installation of those units prior to installation.

This information is provided for the field service personnel to install refrigerant tubing in compliance with Section 608 of Title VI National Recycling and Emission Reduction Program for the U.S. Clean Air Act effective July 1, 1992.

Consult manual 2100-002 on procedure for leak test--evacuation--charging before installation refrigerant tubing that requires any refrigerant recovery or system evacuation. Manual 2100-002 is included with the unit installation instruction package when shipped from the factory.

PRECHARGED TUBING CONNECTIONS: QUICK CONNECT INDOOR UNIT AND QUICK CONNECT OUTDOOR UNIT (1)

Examine carefully the two lengths of precharged tubing furnished with the system. The larger is the suction line and the smaller is the liquid line. The end of the tubing with the hex nut and gauge port is to be attached to the outdoor unit.

STEP 1--Unroll the tubing, being careful not to kink and route both the suction line and liquid line between the indoor unit and outdoor unit.

Before fastening either end, use a tubing bender to make any necessary bends in tubing. When necessary to bend the insulated tube suction line, cut the insulation around its circumference at a distance far enough beyond the point of the bend so as to clear the tubing bender. Slip the insulation back together and vapor seal the joint with tape. Coil any excess tubing in a horizontal place with the slope of the tubing toward the condensing unit.

CAUTION: 1. Be careful not to tear the insulation when pushing it through hole in masonry or frame walls. 2. When sealing the tube opening in house wall, use a soft material to prevent tube damage and vibration transmission. 3. Avoid excessive bending in any one place to avoid kinking.

NOTE: DO NOT CONNECT LINE SETS! If orifice needs to be changed, change out orifice first.

If the orifice does not have to be changed, skip the instructions outlined further in Step 2 and proceed to Step 9.

STEP 2--To recover charge from the indoor unit.

- A. Connect the suction line only to the indoor unit as outlined in Steps 9, 10, and 11.
- B. Recover indoor unit and suction line unit charge through service port located on suction line.

STEP 3--Disassemble Flow Control Assembly by turning body hex.

STEP 4--If existing orifice has not dropped out of the body when disassembled, remove by using a pin or paper clip. Discard this original orifice.

STEP 5--Insert proper sized orifice fully into the flow control body with rounded "bullet" nose towards the unit as shown. Insure the orifice stays inserted in body before connecting mating half. See chart in the outdoor unit installation instructions for proper size.

CAUTION: Be sure there is no dirt introduced into the flow control--orifice assembly. Be sure and install the orifice with the bullet nose pointing in the proper direction as shown in Figure 9. Failure to do so will result in improper operation.

FIGURE 9
FLOW CONTROL ASSEMBLY
FIELD ORIFICE REPLACEMENT INSTRUCTIONS

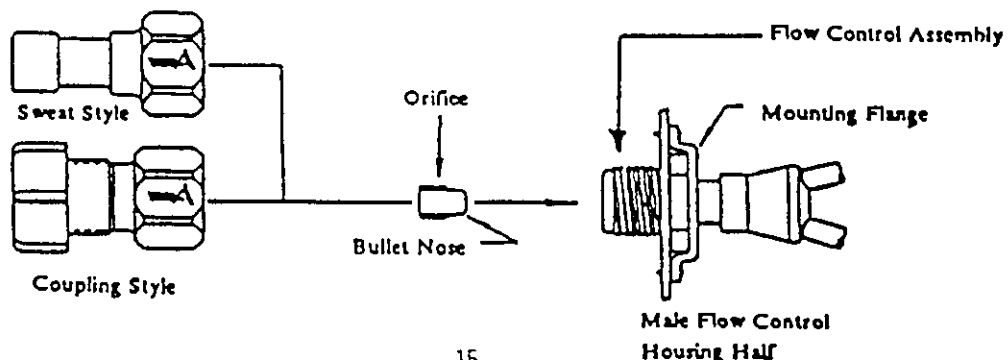

STEP 6--Thread assembly halves together by hand to insure proper mating of threads and tighten until bodies "bottom" or a definite resistance is felt.

STEP 7--Using a marker pen or ink pen, mark a line lengthwise from the union nut to the bulkhead. Then tighten an additional 1/6 turn (or 1 hex flat). The misalignment of the line will show the amount the assembly has been tightened. This final 1/6 turn is necessary to insure the formation of the leakproof joint.

STEP 8--Evacuate the suction line and indoor unit through service port located on suction line before connecting all other tubing. Refer to section later in installation instructions for details on setting the proper refrigerant charge.

STEP 9--Remove (remaining) protector caps and plugs (if orifice was changed), inspect fittings and if necessary carefully wipe coupling seats and threaded surfaces with a clean cloth to prevent the inclusion of dirt or any foreign material in the system.

STEP 10--Lubricate male half diaphragm and synthetic rubber seal with refrigerant oil. Starting with the indoor coil thread coupling halves together by hand to insure proper mating of threads. Be sure to hold the coupling firmly to prevent movement of the coupling and tubing. Failure to do so could tear out the diaphragm causing a blockage of the system. Use proper size wrenches (on coupling body hex and on union nut) and tighten until coupling bodies "bottom" or a definite resistance is felt.

CAUTION: After starting to tighten up the fitting, never try to back it off or take it apart.

STEP 11--Using a marker or ink pen, mark a line lengthwise from the coupling union nut to the bulkhead. Then tighten an additional 1/4 turn: The misalignment of the line will show the amount the coupling has been tightened. This final 1/4 turn is necessary to insure the formation of leak proof joint. If a torque wrench is used, the following torque values are recommended:

TABLE 9

Coupling Size	Ft. Lbs.
-6	10 - 12
-10	35 - 45
-11	35 - 45
-12	50 - 65

Repeat Step 10 and 11 on outdoor section making sure to locate the gauge port in a 45° angle from a vertical up position so as to be accessible for gauge connections.

STEP 12--Leak test all connections using an electronic leak detector or a halide torch.

STEP 13--When tubing is installed in attics or drop ceilings, insulate the couplings on the larger tube thoroughly with 3/8" wall thickness, closed cell sponge tube insulation or equivalent. Failure to insulate will result in water damage to ceiling since the fitting will "sweat" and drop water on the ceiling.

(1) NOTE: The maximum distance for precharge tubing between the outdoor and indoor unit is 45 feet.

FIELD FABRICATED TUBING CONNECTIONS: SWEAT INDOOR UNIT AND QUICK CONNECT OUTDOOR UNIT USING CTO KIT

Use only refrigeration grade (dehydrated and sealed) copper tubing. Care must be taken to insure that the tubing is kept clean and dry before and during installation. Do not remove the plugs from the tubing ends, coil connections or base valves until the connection is ready to be brazed.

The suction line must be insulated with a minimum of 3/8" Armaflex or equivalent before cutting and making connections.

STEP 1--Being careful not to kink, route both the suction line and liquid line between the indoor unit and outdoor unit. Use a tubing bender to make any necessary bends in tubing. When necessary to bend the insulated tube suction line, cut the insulation around its circumference at a distance far enough beyond the point of the bend so as to clear the tubing bender. Slip the insulation back together and vapor seal the joint with tape. Coil any excess tubing in a horizontal place with the slope of the tubing toward the condensing unit.

CAUTION: 1. Be careful not to tear the insulation when pushing it through hole in masonry or frame walls. 2. When sealing the tube opening in house wall, use a soft material to prevent tube damage and vibration transmission. 3. Avoid excessive bending in any one place to avoid kinking.

STEP 2--The tubing ends should be cut square. Make sure it is round and free of burrs at the connecting ends. Clean the tubing to prevent contaminants from entering the system.

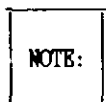

Do not braze lines to indoor unit or make any tubing connections at outdoor unit at this time.

If the orifice does not have to be changed, skip the instructions outlined further in Step 3 and proceed to Step 8.

STEP 3--Disassemble Flow Control Assembly by turning body hex.

STEP 4--If existing orifice has not dropped out of the body when disassembled, remove by using a pin or paper clip. Discard this original orifice.

STEP 5--Insert proper sized orifice fully into the flow control body with rounded "bullet" nose towards the unit as shown. Insure the orifice stays inserted in body before connecting mating half. See chart in the outdoor unit installation instructions for proper size.

CAUTION: Be sure there is no dirt introduced into the flow control--orifice assembly. Be sure and install the orifice with the bullet nose pointing in the proper direction as shown in Figure 9. Failure to do so will result in improper operation.

STEP 6--Thread assembly halves together by hand to insure proper mating of threads and tighten until bodies "bottom" or definite resistance is felt.

STEP 7--Using a marker pen or ink pen, mark a line lengthwise from the union nut to the bulkhead. Then tighten an additional 1/6 turn (or 1 hex flat). The misalignment of the line will show the amount the assembly has been tightened. This final 1/6 turn is necessary to insure the formation of the leakproof joint.

STEP 8--DO NOT make any tubing connection at outdoor unit at this time. Make all brazing of joints and evacuate both suction line, liquid line, and indoor coil first.

Wrap a wet rag around the copper stub before brazing.

STEP 9--Flux the copper tube and insert into the stub. Braze the joint using an alloy of silver or copper and phosphorus with a melting temperature above 1100°F for copper to copper joints. The phosphorus will act as a flux, therefore, no flux will be required.

A copper-silver alloy with a high silver content should be used when iron or steel material is involved in the joint. These alloys require the use of silver solder flux. Alloys containing phosphorus should not be used with iron or steel. Phosphorus reacts with iron, forming iron phosphate which is extremely brittle.

CAUTION: 1. Brazing alloys with a melting temperature below 700°F should not be used. 2. Lead-tin or tin-antimony solders should not be used due to their low melting point and necessity for corrosive fluxes.

To further prevent the formation of copper oxide inside the tubing, dry nitrogen may be purged through the refrigerant system during brazing.

WARNING: Never purge or pressurize a system with oxygen. An explosion and fire will result.

STEP 10--After brazing, quench with wet rag to cool the joint and remove any flux residue.

STEP 11--Leak test all connections using an electronic leak detector or a halide torch.

STEP 12--Evacuate the suction line, liquid line, and indoor unit through service ports located on suction and liquid line before connecting to outdoor unit. Refer to section later in installation instructions for details on setting the proper refrigerant charge.

STEP 13--Remove (remaining) protector caps and plugs (on outdoor unit). Inspect fittings and if necessary carefully wipe coupling seats and threaded surfaces with a clean cloth to prevent the inclusion of dirt or any foreign material in the system.

STEP 14--Lubricate male half diaphragm and synthetic rubber seal with refrigerant oil. Start with the indoor coil, thread coupling halves together by hand to insure proper mating of threads. Be sure to hold the coupling firmly to prevent movement of the coupling and tubing. Failure to do so could tear out the diaphragm causing a blockage of the system. Use proper size wrenches (on coupling body hex and on union nut) and tighten until coupling bodies "bottom" or a definite resistance is felt.

CAUTION: After starting to tighten up the fitting, never try to back it off or take it apart.

STEP 15--Using a marker or ink pen, mark a line lengthwise from the coupling union nut to the bulkhead. Then tighten an additional 1/4 turn: The misalignment of the line will show the amount the coupling has been tightened. This final 1/4 turn is necessary to insure the formation of leak proof joint. If a torque wrench is used, the following torque values are recommended.

TABLE 10

Coupling Size	Ft. Lbs.
-6	10 - 12
-10	35 - 45
-11	35 - 45
-12	50 - 65

STEP 16--Leak test all connections using an electronic leak detector or a halide torch.

STEP 17--When tubing is installed in attics or drop ceilings, insulate the couplings on the larger tube thoroughly with 3/8" wall thickness, closed cell sponge tube insulation or equivalent. Failure to insulate will result in water damage to ceiling since the fitting will "sweat" and drop water on the ceiling.

V. WIRING INSTRUCTIONS

GENERAL

All wiring must be installed in accordance with the National Electrical Code and local codes. Power supply voltage must conform to the voltage shown on the unit serial plate. A wiring diagram of the unit is attached to the inside of the electrical cover. The power supply shall be sized and fused according to the specifications supplied. A ground lug is supplied in the control compartment for equipment ground.

The control circuit is a 24 volt circuit. "Typical" wiring diagrams illustrating some of the various circuits which could be encountered can be found later in this instruction.

The unit rating plate lists a "Maximum Time Delay Fuse" or "HACR Type" circuit breaker that is to be used with the equipment. The correct size must be used for proper circuit protection and also to assure that there will be no nuisance tripping due to the momentary high starting current of the compressor motor.

DISCHARGE TEMPERATURE SENSOR

Each scroll compressor is equipped with discharge temperature sensor located on the outside top of the compressor. The sensor is a SPST thermostat which opens when the discharge temperature exceeds 280 degrees F + 8 degrees F on a temperature rise. When the switch opens, the circuit to the compressor contactor is de-energized and unit shuts off. The switch automatically resets when the compressor temperature drops below 130 degrees F + 14 degrees F.

The sensor can be accessed by prying on the snap plug on top of the compressor (See Figure 10). Make sure to securely reseal the sensor after replacement. The sensor terminals are located inside the compressor terminal box. Figure 11 shows the arrangement of compressor line voltage terminals and discharge sensor terminals.

FIGURE 10

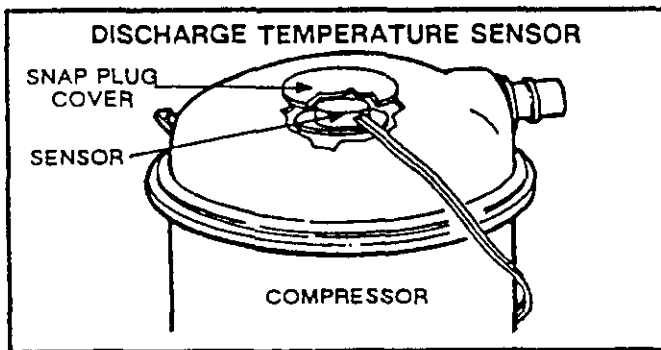
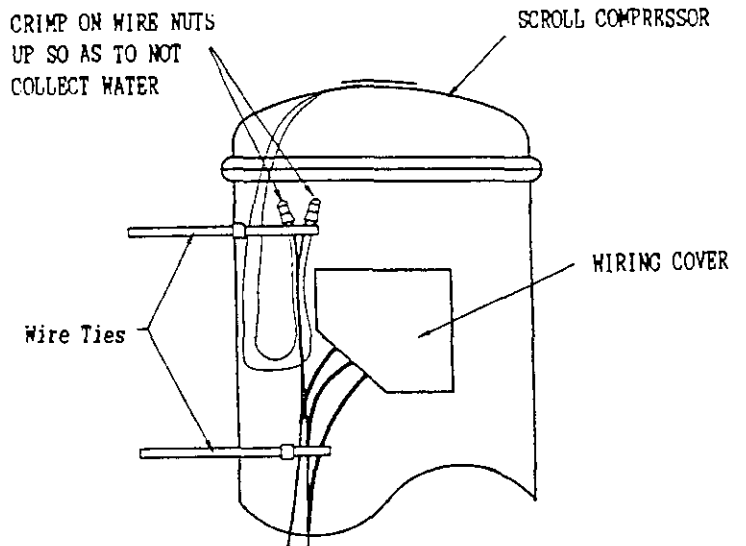

FIGURE 11



To start and check balance the unit, see the "Sequence of Operation" and "System Start-Up Procedures" in the installation instructions.

VI. SEQUENCE OF OPERATION--WQS WITH FOSSIL FUEL FURNACE

1. First Stage Heating

On a call for heating a circuit is made between R and Y at the room thermostat. At the same time a circuit is made between R and G. The "G" circuit energizes the blower relay of the fan center. The blower relay contacts complete a circuit to the furnace blower motor and the blower runs. The Y circuit is routed to the Y terminal of the compressor section and then to terminal 4 of the lockout relay. Terminal 4 of the lockout relay provides three possible paths for the current to take.

- A. Terminal 4 to 2--only possible if the lockout relay is energized.
- B. Terminal 4 to 3--in combination with the compressor contactor coil and offers high resistance to current flow.
- C. Terminal 4 to 5--path of least resistance. Current flows until lockout relay is energized. From terminal 5 of the lockout relay the Y circuit continues through the low and high pressure switches (normally closed) to the normally closed contacts (5 and 6) of the fossil fuel relay and then to the compressor contactor coil. The compressor contactor coil is energized and a high voltage circuit is made to the compressor and the compressor runs. Since the "O" terminal is not energized, the reversing valve solenoid is not energized and the unit is in heating.

NOTE: For oil furnaces use an isolation relay to keep the two transformer circuits separated. Connect the isolation relay coil between "V" and "C". Connect the oil primary thermostat terminals to the switch contacts of the isolation relay.

2. Second Stage Starts Gas Burner (Or Oil Burner)

When the second stage bulb of the wall thermostat makes, a circuit is completed between R and W2 of the wall thermostat. This circuit is routed to W2 of the compressor section and then to terminal 3 of the fossil fuel relay--the relay is energized. Normally closed contacts (5 and 6 of the fossil fuel relay) in the compressor contactor coil circuit open and the compressor contactor coil drops out. The compressor no longer is running. Normally open contacts (2 and 4 of the fossil fuel relay) close and the W2 circuit continues from terminal 3 of the fossil fuel relay to terminal 4 across the now closed contact to terminal 2 and then to terminal V of the compressor section. Terminal V is connected to the gas valve solenoid which is now energized and the gas valve opens. Fossil fuel furnace is now energized.

3. First Stage Keeps Gas Burner Operating (Or Oil Burner)

When the compressor contactor coil circuit is interrupted by the functioning of the fossil fuel relay (5 and 6 open), the path of least resistance for the Y circuit is no longer to the compressor contactor coil (4 to 5 of the lockout relay). Current can now flow through the lockout relay coil (4 to 3) returning through the compressor contactor coil as a wire and proceeding to the common side of the transformer. The lockout relay is energized. The resistance of the lockout relay coil causes a voltage drop sufficient to prevent the compressor contactor coil from energizing (no longer 24 volts at the compressor contactor coil) and the compressor is prevented from running.

When the lockout relay coil is energized, the Y circuit (first stage heating) is rerouted from 4 and 5 of the lockout relay (now open) to 4 and 2 of the lockout relay (now closed). From terminal 2 of the lockout relay the first stage heating Y circuit goes to the normally closed contacts (5 and 6) of the changeover relay. From the changeover relay the circuit goes to terminal V of the compressor section and then to the gas valve. The gas valve, therefore, though originally energized by second stage heating, will not shut off until first stage heating is satisfied.

The purpose of the changeover relay is to prevent operation of the gas valve when the lockout relay is energized in cooling (for example high pressure switch opens). The coil of the changeover relay is connected to the "O" terminal (only energized in cooling) and, therefore, the changeover relay contacts (5 and 5--normally closed) are open in cooling--gas valve is prevented from operating.

4. Cooling

When the system switch of the wall thermostat is moved to COOL, a circuit is completed from R to O (whether the cooling bulb is made or not). The "O" terminal is connected to the reversing valve solenoid and the changeover relay coil. The reversing valve solenoid and the changeover relay coil are energized and stay energized until the system switch of the wall thermostat is moved from the cool position (to OFF, HEAT or EM. HEAT).

When the cooling bulb makes, the Y circuit is energized and follows the path described above for first stage heating. The compressor runs and, since the reversing valve is energized, the unit is in cooling.

5. Check Light

If the Y circuit to the contactor coil is interrupted because the high (low) pressure switch opens, the Y circuit takes the path of least resistance at the lockout relay and goes from 4 to 3 of the lockout relay and the lockout relay coil is energized. The lockout relay coil will remain energized until the Y circuit is broken either by moving the system switch to OFF or by satisfying the first stage heating/cooling bulb. The Y circuit then takes the same path as described above, first stage heating (namely, in heating, from lockout relay terminals 4 to 2--now closed--to normally closed contacts 5 and 6 of the changeover relay to terminal Y and then to the gas valve; in cooling normally closed contacts 5 and 6 of the changeover relay are open--coil energized--and the circuit to the gas valve is broken.

When refrigerant pressures equalize, the high (low) pressure switch automatically resets (pressure switch contacts close). However, the compressor contactor coil circuit is still interrupted at the lockout relay (terminal 4 and 5 open). The Y circuit is connected to X2 of the wall thermostat through a jumper. X2 of the thermostat is internally connected to L through the check light of the wall thermostat.

The check light circuit may be traced as follows: R through the heating/cooling bulb to Y. Y to X2 through the check light to L. L of the wall thermostat to L of the compressor section to 5 of the lockout relay (4 to 5 of the lockout relay open due to function of the high (low) pressure switch and lockout relay). Terminal 5 of the lockout relay to one side of the low pressure switch. Low pressure switch (refrigerant pressure equalized and pressure switch reset in closed position) to the high pressure switch (also closed or reset and closed) to 5 and 6 of the fossil fuel relay and then to the contactor coil as a wire and back to the common side of the transformer. The check light circuit is complete and the light is on.

The check light does not come on until the lockout relay coil is energized, breaking the Y circuit at terminals 4 and 4 of the lockout relay. The check light will remain energized until the lockout relay is de-energized--system switch moved to OFF or the heat/cool thermostat bulb is satisfied.

TABLE 11

Part No.	Model No.	Description
8403-017	T874R1129	THERMOSTAT--1 stg. cool, 2 stg. heat, 1st stage fixed, 2nd stg. adj. heat anticipators
8404-009	Q674L1181	SUBBASE --System switch: Em. Heat-Heat-Off-Cool Fan switch: On-Auto SPECIAL FEATURE: Manual Changeover (Non-Cycling Rev. Valve) Em. heat light and System check light
8403-024	IP58-45	THERMOSTAT--1 stg. cool, 2 stg. heat, 1st stage fixed, 2nd stg. adj. heater System switch: Em. Heat-Heat-Off-Cool Fan Switch: On-Auto

IMPORTANT NOTE: All thermostat and subbase combinations shown above incorporate the following features: Man-Auto fan switch, Off-Heat-Cool-Em. Heat Switch, and two (2) indicator lamps--one for emergency heat and one for compressor malfunction.

THERMOSTAT INDICATOR LAMPS

The red lamp marked "EM.HT." comes on and stays on whenever the system switch is placed in the emergency heat position. The green lamp marked "check" will come on if the high or low pressure (low temp cut-off) switch opens and that prevents the compressor from running. To reset pressure switches, place thermostat in off position then back to on position.

COMPRESSOR SHORT CYCLE PROTECTION

The water source heat pump control circuit includes a built in compressor short cycle protection that will prevent the compressor from restarting until compressor has been off for at least five minutes.

EMERGENCY HEAT POSITION

The operator of the equipment must manually place the system switch in this position. This is done when there is a known problem with the compressor section, or when the green "check" lamp comes on indicating a problem.

VII. CHARGING INSTRUCTIONS

PRESSURE SERVICE PORTS

High and low pressure service ports are installed on all units so that the system operating pressures can be observed. Pressure tables can be found later in the manual covering all models. It is imperative to match the correct pressure table to the unit by model number.

The pressure service ports on the split system heat pump are located on the interconnecting tubing quick connect fittings. An additional low side service port is located on the quick connect mounting plate for low side pressure during heating operation.

REFRIGERANT CHARGE

The correct system R-22 is shown on the unit rating plate. Optimum unit performance will occur with a refrigerant charge resulting in a suction line temperature (6" from compressor) as shown in the following table:

TABLE 12

Models	Rated Airflow	GPM	70 Degrees F EW Temp.	50 Degrees F EW Temp.
WQS30A/BC24B	875	5	50 - 52	65 - 67
WQS30A/A36AQ-A	1100	5	49 - 51	63 - 65
WQS36A/BC36B	1150	5	46 - 48	66 - 68
WQS36A/A36AQ-A	1200	5	47 - 49	62 - 64
WQS42A/BC36B	1150	6	41 - 43	61 - 63
WQS42A/A42AQ-A	1450	6	47 - 49	54 - 56

NOTE: The suction line temperatures are based upon 80 degrees F dry bulb/67 degrees F wet bulb (50% R.H.) temperature and rated air flow across the indoor coil during cooling cycle.

TOTAL SYSTEM CHARGE FOR SPLIT SYSTEMS

The following tables are used to determine the operating charge for split air conditioning and heat pump systems. The values shown are the total amount of refrigerant received in the precharged system components, which include the compressor unit, indoor unit, and inter-connecting tubing. This is also the amount of refrigerant required for a system recharge following any refrigeration system repairs.

Find the compressor section and matching indoor section (Table 13) and connecting tubing set (Table 14) for system being used. Add the ounces of charge for each of the system components together. This value is the **TOTAL SYSTEM CHARGE**.

$$\begin{array}{r} \text{COMPRESSOR UNIT} \\ \text{(Table 14)} \end{array} \text{ OZs} + \begin{array}{r} \text{INDOOR UNIT} \\ \text{(Table 14)} \end{array} \text{ OZs} + \begin{array}{r} \text{TUBING SET} \\ \text{(Table 13)} \end{array} \text{ OZs} = \begin{array}{r} \text{TOTAL SYSTEM CHARGE} \\ \text{OZs} \end{array}$$

To change total charge to lbs. and ozs., divide by 16.

EXAMPLE: WQS36A with A36AQ-A and CT25 tubing set.

$$\begin{array}{r} 56.5 \\ \hline \end{array} \text{ OZs} + \begin{array}{r} 8 \\ \hline \end{array} \text{ OZs} + \begin{array}{r} 3 \\ \hline \end{array} \text{ OZs} = \begin{array}{r} 67.5 \\ \hline \end{array} \text{ OZs}$$

$$\text{or } \frac{67.5}{16} = 4 \text{ lbs. } 3.5 \text{ ozs.}$$

TABLE 13 SYSTEM OPERATING CHARGE

Compressor Unit	Compressor Unit Factory Charge	For Use With Indoor Unit	Indoor Unit Factory Charge
WQS30A	51 oz.	A36AQ-A BC24B	8 oz. 5 oz.
WQS36A	56.5 oz.	A36AQ-A BC36B (1)	8 oz. 13 oz.
WQS42A	88.5 oz.	A42AQ BC36B	8 oz. 13 oz.

(1) When using BC36B with WQS36A, total system charge must be increased by 11-1/2 ounces.

To determine TUBING SET ONLY charges, use the following table.

TABLE 14 (Shows Charge In Ounces)

Tubing Set Length in Ft.	10	15	20	25	30	35	40	45	50	55	60
RW Series 1/4" O.D. Liquid Line	2	2	3	3	5	7	9	11	--	--	--
CT Series 3/8" O.D. Liquid Line	2	2	5	8	11	14	17	20	23	26	29

To determine a **TOTAL SYSTEM CHARGE** for a system that is connected with a non-standard tubing length, the compressor basic charge (from Table 13) plus the indoor unit basic charge (from Table 13), is added to the tube set based on liquid line O.D. size (Table 14). This value is the **TOTAL SYSTEM CHARGE**.

NOTE: If your tubing length is between the sizes shown in the table, use a charge value appropriately between the values shown for the tubing length shorter and longer than actual length.

In the event that the installer is running his own tubing by using a CTO kit or is modifying a precharged tubing set by adding or subtracting a few feet of tubing length, the tubing set should be evacuated and charged before being connected to the compressor and indoor section. In the event that a sweat type indoor coil is being installed, braze the line set to the indoor coil and evacuate and charge both coil and line set prior to connecting to compressor unit.

APPLICATION GUIDELINES

To determine a total system charge for a system that is connected with a non-standard tubing length, the compressor basic charge (from Table 13) plus the indoor basic unit charge (from Table 13) is added to the tubing charge adjustment (rounded to next higher full ounce), see Table 12, based on liquid line size. This value is the total system charge.

EXAMPLE: WQS36A with A36AS-A and 45 feet 3/8" O.D liquid line

$$56.5 \text{ ozs.} + 0 \text{ oz.} + (.6 \times 45) 27 \text{ oz.} = 83.5 \text{ oz.}$$

$$\text{OR } \frac{83.5}{16} = 5 \text{ lb. } 3.5 \text{ oz.}$$

Application guidelines: For tubing sizes up to 45 feet, use liquid line size and suction line size as shown for precharged tubing sets (see Table 9). For tubing sizes for systems between 46 feet and 100 feet in length, use size recommended in table below. Adjust tubing charge by adding the additional refrigerant indicated in Table 16 to the base charge for 25 feet of charged tubing (liquid line size) shown in Table 14.

TABLE 15

Approved 25 Feet Charged Tubing Sizes		Tubing Size Recommended (1)			
		45 - 75 Ft.		76 - 100 Ft.	
Liquid	Vapor	Liquid	Vapor	Liquid	Vapor
1/4"	5/8"	1/4"	3/4"	3/8"	3/4"
1/4"	3/4"	1/4"	7/8"	3/8"	7/8"
3/8"	3/4"	3/8"	7/8"	1/2"	7/8"
3/8"	7/8"	3/8"	7/8"	1/2"	1-1/8"

- (1) These recommendations are based on the use of standard refrigeration tubing.
- (1) Line sizes listed are outside tube dimensions.
- (1) These suggestions do not include consideration for additional pressure drop due to elbows, valves, or reduced joint sizes.
- (1) These recommendations are to be applied to approved combinations of Bard compressor and indoor sections only.

The basis for selection is to maintain adequate velocity which assures adequate oil return to the compressor, an acceptable pressure drop to assure compressor capacity and minimum tubing costs.

Charge adjustments for tubing sizes are as follows (2):

TABLE 16

Tubing Sizes	Charge Adjustment (2)
1/4" liquid line	.2 oz. R-22 per foot
3/8" liquid line	.6 oz. R-22 per foot
1/2" liquid line	1.2 oz. R-22 per foot

- (2) These values should only be applied during initial system charging. System operating charge should be adjusted for optimum performance outlined in the installation instructions for specific compressor unit.

FINAL CHECKLIST

Before starting unit after installation or servicing, check the following:

1. Proper voltage to unit.
2. Correct fuse sizes.
3. Tight electrical connections.
4. Water system clean and flushed.
5. Air purged from water system.
6. Adequate water flow and pressure to the unit.
7. Condensate line clear and unclogged.
8. Blower wheel free to rotate.
9. Return air filter is installed.
10. Access panels and enclosures are installed and secured.

VIII. SYSTEM START UP PROCEDURE

1. Be sure main power to the unit is OFF at the disconnect.
 2. Set thermostat system switch to OFF, fan switch to AUTO.
 3. Move main power disconnect to ON.
 4. Check system air flow for obstructions.
 - A. Move thermostat fan switch to ON. Blower runs.
 - B. Be sure all registers and grilles are open.
 - C. Move thermostat fan switch to AUTO. Blower should stop.
 5. Fully open the manual inlet and outlet valves.
 6. Check water flow.
 - A. Connect a water flow meter to the drain cock (12, Figure 2) between the constant flow valve and the solenoid valve. Run a hose from the flow meter to a drain or sink. Open the drain cock.
 - B. Check the water flow rate through constant flow valve to be sure it is the same as the unit is rated for.

Example: 5 GPM for a WQS30A
 - C. When water flow is okay, close drain cock and remove the water flow meter. The unit is now ready to start.
 7. Start the unit in cooling mode. (1) By moving the thermostat switch to cool, fan should be set for AUTO.
 8. Check the system refrigerant pressures against the cooling refrigerant pressure Tables 15, 17, and 19 in the installation manual for rated water flow and entering water temperatures. If the refrigerant pressures do not match, check for air flow problem then refrigeration system problem.
 9. Switch the unit to the heating mode. (1) By moving the thermostat switch to heat, fan should be set for AUTO.
 - A. Check to see the solenoid valve opened again.
 10. Check the refrigerant system pressures against the heating refrigerant pressure Tables 14, 16 and 18 in installation manual. Once again, if they do not match, check for air flow problems and then refrigeration system problems.

NOTE: If a charge problem is determined (high or low):

 - A. Check for possible refrigerant leaks.
 - B. Discharge all remaining refrigerant from unit.
 - C. Evacuate unit down to 29 inches of vacuum.
 - D. Recharge the unit with refrigerant by weight. This is the only way to insure a proper charge.
- (1) For models in use with optional domestic hot water heat exchanger, be sure the water pump switch is off while checking refrigerant system.

IX. SERVICE

SERVICE HINTS

1. Caution homeowner to maintain clean air filters at all times. Also, not to needlessly close off supply and return air registers. This reduces air flow through the system, which shortens equipment service life as well as increasing operating costs.
2. The heat pump wall thermostats perform multiple functions. Be sure that all function switches are correctly set for the desired operating mode before trying to diagnose any reported service problems.
3. Check all power fuses or circuit breakers to be sure that they are the correct rating.

X. WATER CORROSION

Two concerns will immediately come to light when considering a water source heat pump, whether for ground water or for a closed loop application: Will there be enough water? And, how will the water quality affect the system?

Water quantity is an important consideration and one which is easily determined. The well driller must perform a pump down test on the well according to methods described by the National Well Water Association. This test, if performed correctly, will provide information on the rate of flow and on the capacity of the well. It is important to consider the overall capacity of the well when thinking about a water source heat pump because the heat pump may be required to run for extended periods of time.

The second concern, about water quality, is equally important. Generally speaking, if the water is not offensive for drinking purposes, it should pose no problem for the heat pump. The well driller or local water softening company can perform tests which will determine the chemical properties of the well water.

Water quality problems will show up in the heat pump in one or more of the following ways:

1. Decrease in water flow through the unit.
2. Decreased heat transfer of the water coil (entering to leaving water temperature difference is less).

There are four main water quality problems associated with ground water. These are:

1. **BIOLOGICAL GROWTH.** This is the growth of microscopic organisms in the water and will show up as a slimy deposit throughout the water system. Shock treatment of the well is usually required and this is best left up to the well driller. The treatment consists of injecting chlorine into the well casing and flushing the system until all growth is removed.
2. **SUSPENDED PARTICLES IN THE WATER.** Filtering will usually remove most suspended particles (fine sand, small gravel) from the water. The problem with suspended particles in the water is that it will erode metal parts, pumps, heat transfer coils, etc. So long as the filter is cleaned and periodically maintained, suspended particles should pose no serious problem. Consult with your well driller.
3. **CORROSION OF METAL.** Corrosion of metal parts results from either highly corrosive water (acid water, generally not the case with ground water) or galvanic reaction between dissimilar metals in the presence of water. By using plastic plumbing or di-electric unions galvanic reaction is eliminated. The use of corrosion resistant materials (such as the Cupro Nickel coil) throughout the water system will reduce corrosion problems significantly.
4. **SCALE FORMATION.** Of all the water problems, the formation of scale by ground water is by far the most common. Usually this scale is due to the formation of calcium carbonate but magnesium carbonate or calcium sulfate may also be present. Carbon dioxide gas (CO₂), the carbonate of calcium and magnesium carbonate, is very soluble in water. It will remain dissolved in the water until some outside factor upsets the balance. This outside influence may be a large change in water temperature or pressure. When this happens, enough carbon dioxide gas combines with dissolved calcium or magnesium in the water and

falls out of solution until a new balance is reached. The change in temperature that this heat pump produces is usually not high enough to cause the dissolved gas to fall out of solution. Likewise if pressure drops are kept to a reasonable level, no precipitation of carbon dioxide should occur.

XI. REMEDIES OF WATER PROBLEMS

WATER TREATMENT. Water treatment can usually be economically justified for closed loop systems. However, because of the large amounts of water involved with a ground water heat pump, water treatment is generally too expensive.

ACID CLEANING THE WATER COIL OR HEAT RECOVERY UNIT. If scaling of the coil is strongly suspected, the coil can be cleaned up with a solution of Phosphoric Acid (food grade acid). Follow the manufacturer's directions for mixing, use, etc. Refer to "Acid Cleaning Water Coil", Figure 12. The acid solution can be introduced into the heat pump coil through the hose bib (Part 8 of Figure 12). Be sure the isolation valves (Parts 9 and 11 of Figure 12) are closed to prevent contamination of the rest of the system by the coil. The acid should be pumped from a bucket into the hose bib (Part 8, Figure 12) and returned to the bucket through the other hose bib (Part 10, Figure 12). Follow the manufacturer's directions for the product used as to how long the solution is to be circulated, but it is usually circulated for a period of several hours.

FIGURE 12
ACID CLEANING OF WATER COIL

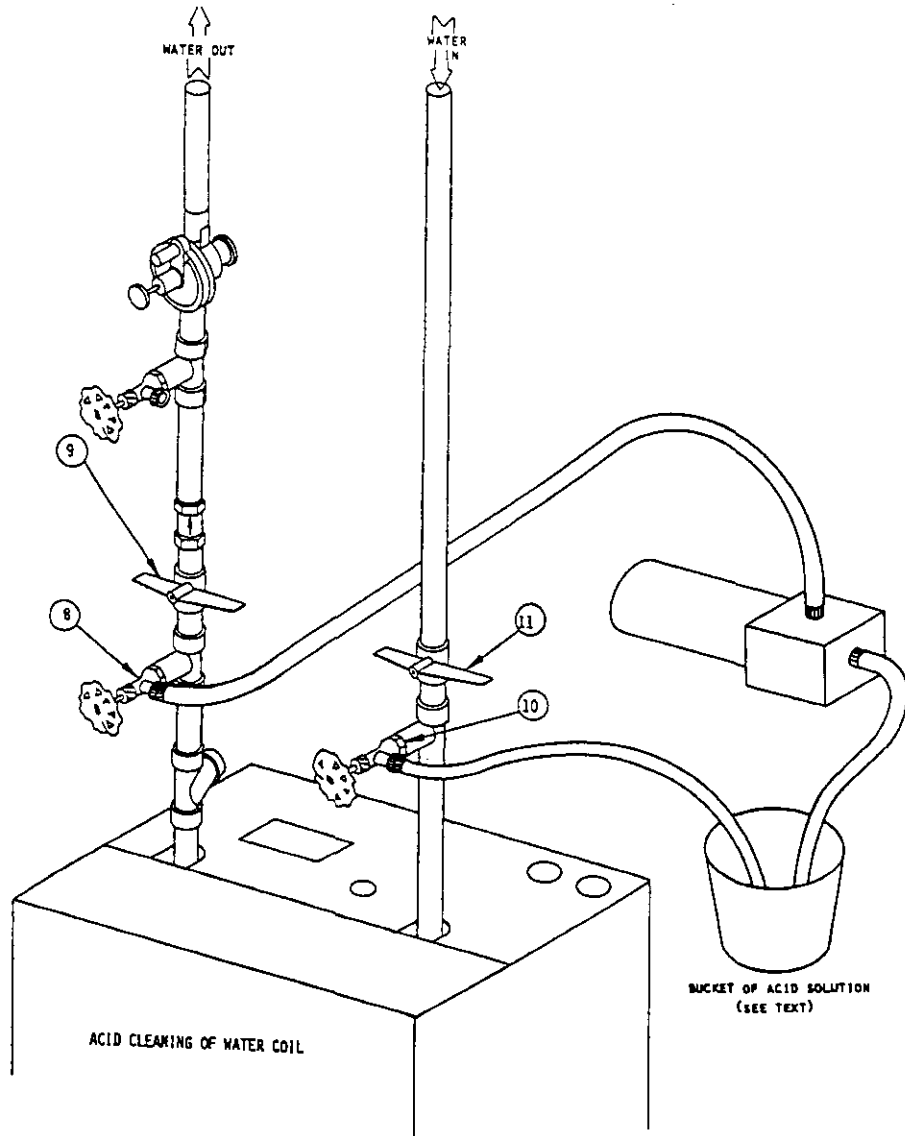

QUICK REFERENCE TROUBLE-SHOOTING CHART FOR WATER TO AIR HEAT PUMP

PROBLEM CONDITION	POSSIBLE CAUSE																				
	POWER SUPPLY				CONTROL CIRCUIT				COMPRESSOR				WATER COIL SECTION				INDOOR SECTION				AUX.
	LINE VOLTAGE	CONTROL CIRCUIT	COMPRESSOR	REFRIGERANT SYSTEM	WATER SOLENOID	REV. CHECKS VALVE	WATER COIL	INDOOR BLOWER MOTOR & COIL	CHECK VALVE	HEAT GEN.											
POWER FAILURE	●	●	●	●	●	●	●	●	●	●	●	●	●	●	●	●	●	●	●	●	●
BLOWN FUSE OR TRIPPED BREAKER	●	●	●	●	●	●	●	●	●	●	●	●	●	●	●	●	●	●	●	●	●
FAULTY WIRING	●	●	●	●	●	●	●	●	●	●	●	●	●	●	●	●	●	●	●	●	●
LOOSE TERMINALS	●	●	●	●	●	●	●	●	●	●	●	●	●	●	●	●	●	●	●	●	●
LOW VOLTAGE	●	●	●	●	●	●	●	●	●	●	●	●	●	●	●	●	●	●	●	●	●
DEFECTIVE CONTACTS IN CONTACTOR	▲	●	●	●	●	●	●	●	●	●	●	●	●	●	●	●	●	●	●	●	●
COMPRESSOR OVERLOAD	▲	●	●	●	●	●	●	●	●	●	●	●	●	●	●	●	●	●	●	●	●
POTENTIAL RELAY	●	●	●	●	●	●	●	●	●	●	●	●	●	●	●	●	●	●	●	●	●
RUN CAPACITOR	●	●	●	●	●	●	●	●	●	●	●	●	●	●	●	●	●	●	●	●	●
START CAPACITOR	●	●	●	●	●	●	●	●	●	●	●	●	●	●	●	●	●	●	●	●	●
FAULTY WIRING	●	●	●	●	●	●	●	●	●	●	●	●	●	●	●	●	●	●	●	●	●
LOOSE TERMINALS	●	●	●	●	●	●	●	●	●	●	●	●	●	●	●	●	●	●	●	●	●
FAULTY WIRING	●	●	●	●	●	●	●	●	●	●	●	●	●	●	●	●	●	●	●	●	●
INDOOR BLOWER RELAY	●	●	●	●	●	●	●	●	●	●	●	●	●	●	●	●	●	●	●	●	●
DISCH. LINE HITTING INSIDE OF SHELL	●	●	●	●	●	●	●	●	●	●	●	●	●	●	●	●	●	●	●	●	●
BEARINGS DEFECTIVE	●	●	●	●	●	●	●	●	●	●	●	●	●	●	●	●	●	●	●	●	●
SEIZED	●	●	●	●	●	●	●	●	●	●	●	●	●	●	●	●	●	●	●	●	●
VALVE DEFECTIVE	●	●	●	●	●	●	●	●	●	●	●	●	●	●	●	●	●	●	●	●	●
MOTOR WINDINGS DEFECTIVE	●	●	●	●	●	●	●	●	●	●	●	●	●	●	●	●	●	●	●	●	●
REFRIGERANT CHARGE LOW	●	●	●	●	●	●	●	●	●	●	●	●	●	●	●	●	●	●	●	●	●
REFRIGERANT OVERCHARGE	●	●	●	●	●	●	●	●	●	●	●	●	●	●	●	●	●	●	●	●	●
HIGH HEAD PRESSURE	●	●	●	●	●	●	●	●	●	●	●	●	●	●	●	●	●	●	●	●	●
LOW HEAD PRESSURE	●	●	●	●	●	●	●	●	●	●	●	●	●	●	●	●	●	●	●	●	●
HIGH SUCTION PRESSURE	●	●	●	●	●	●	●	●	●	●	●	●	●	●	●	●	●	●	●	●	●
LOW SUCTION PRESSURE	●	●	●	●	●	●	●	●	●	●	●	●	●	●	●	●	●	●	●	●	●
NON-CONDENSABLES	●	●	●	●	●	●	●	●	●	●	●	●	●	●	●	●	●	●	●	●	●
UNEQUALIZED PRESSURES	●	●	●	●	●	●	●	●	●	●	●	●	●	●	●	●	●	●	●	●	●
SOLENOID VALVE STUCK CLOSED (HTG)	●	●	●	●	●	●	●	●	●	●	●	●	●	●	●	●	●	●	●	●	●
SOLENOID VALVE STUCK OPEN (HTG OR CLG)	●	●	●	●	●	●	●	●	●	●	●	●	●	●	●	●	●	●	●	●	●
LEAKING	●	●	●	●	●	●	●	●	●	●	●	●	●	●	●	●	●	●	●	●	●
DEFECTIVE VALVE OR COIL	●	●	●	●	●	●	●	●	●	●	●	●	●	●	●	●	●	●	●	●	●
STICKING CLOSED	●	●	●	●	●	●	●	●	●	●	●	●	●	●	●	●	●	●	●	●	●
LEAKING OR DEFECTIVE	●	●	●	●	●	●	●	●	●	●	●	●	●	●	●	●	●	●	●	●	●
PLUGGED OR RESTRICTED METERING DEVICE (HTG)	●	●	●	●	●	●	●	●	●	●	●	●	●	●	●	●	●	●	●	●	●
PLUGGED OR RESTRICTED METERING DEVICE (CLG)	●	●	●	●	●	●	●	●	●	●	●	●	●	●	●	●	●	●	●	●	●
FINS DIRTY OR PLUGGED	●	●	●	●	●	●	●	●	●	●	●	●	●	●	●	●	●	●	●	●	●
MOTOR WINDING DEFECTIVE	●	●	●	●	●	●	●	●	●	●	●	●	●	●	●	●	●	●	●	●	●
AIR FILTERS DIRTY	●	●	●	●	●	●	●	●	●	●	●	●	●	●	●	●	●	●	●	●	●
AIR VOLUME LOW	●	●	●	●	●	●	●	●	●	●	●	●	●	●	●	●	●	●	●	●	●
INDOOR BLOWER MOTOR & COIL	●	●	●	●	●	●	●	●	●	●	●	●	●	●	●	●	●	●	●	●	●
UNDER-SIZED OR RESTRICTED DUCTWORK	●	●	●	●	●	●	●	●	●	●	●	●	●	●	●	●	●	●	●	●	●
STICKING CLOSED	●	●	●	●	●	●	●	●	●	●	●	●	●	●	●	●	●	●	●	●	●
LEAKING OR DEFECTIVE	●	●	●	●	●	●	●	●	●	●	●	●	●	●	●	●	●	●	●	●	●
CHECK VALVE	●	●	●	●	●	●	●	●	●	●	●	●	●	●	●	●	●	●	●	●	●
AUX. HEAT UPSTREAM OF COIL	●	●	●	●	●	●	●	●	●	●	●	●	●	●	●	●	●	●	●	●	●

● DENOTES COMMON CAUSE
 ▲ DENOTES OCCASIONAL CAUSE

PROBLEM CONDITION
 COMPRESSOR WILL NOT RUN
 NO POWER AT CONTACTOR
 COMPRESSOR WILL NOT RUN
 POWER AT CONTACTOR
 COMPRESSOR "HOPS"
 BUT WILL NOT START
 COMPRESSOR CYCLES ON OVERLOAD
 THERMOSTAT CHECK LIGHT
 LITE-LOCKOUT RELAY
 COMPRESSOR OFF ON HIGH
 PRESSURE CONTROL
 COMPRESSOR OFF ON LOW
 PRESSURE CONTROL
 COMPRESSOR NOISY
 HEAD PRESSURE TOO HIGH
 HEAD PRESSURE TOO LOW
 SUCTION PRESSURE TOO HIGH
 SUCTION PRESSURE TOO LOW
 SUCTION PRESSURE TOO LOW
 I. D. BLOWER WILL NOT START
 I. D. COIL FROSTING OR ICING
 HIGH COMPRESSOR AMPS
 EXCESSIVE WATER USAGE
 COMPRESSOR RUNS
 CONTINUOUSLY—NO COOLING
 LIQUID REFRIGERANT FLOODING
 BACK TO COMPRESSOR
 COMPRESSOR RUNS
 CONTINUOUSLY—NO HEATING
 REVERSING VALVE
 DOES NOT SHIFT
 LIQUID REFRIGERANT FLOODING
 BACK TO COMPRESSOR
 AUX. HEAT ON I. D. BLOWER OFF
 EXCESSIVE OPERATING COSTS
 ICE IN WATER COIL

HEATING OR COOLING CYCLES

COOLING CYCLE

HEATING CYCLE

TABLE 17 COOLING Water Temperature Entering Outdoor Coil Degree F

Indoor Section	Return Air Temperature	Pressure	Water Temperature Entering Outdoor Coil Degree F																
			30	35	40	45	50	55	60	65	70	75	80	85	90	95	100	105	110
A36AQ-A	75 deg. DB	Low Side	57	59	61	63	65	67	68	70	71	72	73	74	75	76	77	78	79
	62 deg. WB	High Side	111	119	127	136	146	156	167	179	191	204	217	230	246	261	277	293	310
1100 CFM Rated Flow 5 GPM	80 deg. DB	Low Side	59	62	64	67	69	71	73	75	76	77	78	79	80	81	82	83	84
	67 deg. WB	High Side	114	122	131	140	150	161	172	184	196	209	223	237	252	268	284	301	318
	85 deg. DB	Low Side	63	66	69	71	74	76	78	80	82	83	85	86	87	88	89	90	91
	72 deg. WB	High Side	117	126	135	145	155	166	178	190	203	217	231	246	261	277	294	311	329
BC24B	75 deg. DB	Low Side	59	60	62	63	64	65	66	67	68	69	70	71	72	73	74	75	76
	62 deg. WB	High Side	99	108	117	127	137	137	159	171	183	195	209	223	237	252	268	284	300
875 CFM Rated Flow 5 GPM	80 deg. DB	Low Side	74	63	65	66	68	69	72	72	73	74	75	76	77	78	79	80	81
	67 deg. WB	High Side	101	109	119	129	140	151	163	175	188	201	215	229	244	259	275	291	308
	85 deg. DB	Low Side	65	67	69	71	73	75	76	78	79	80	81	82	83	84	85	86	87
	72 deg. WB	High Side	103	113	123	134	145	157	169	182	195	209	223	238	253	269	285	302	319

TABLE 18 HEATING Water Temperature Entering Outdoor Coil Degree F

Indoor Section	Return Air Temperature	Pressure	Water Temperature Entering Outdoor Coil Degree F										
			30	35	40	45	50	55	60	65	70	75	80
A36AQ-A 1100 CFM Rated Flow 5 GPM	70 D.B.	Low Side	26	31	37	42	47	52	58	63	68	73	79
		High Side	175	180	185	189	194	199	204	208	213	218	223
BC24B 875 CFM Rated Flow 5 GPM	70 D.B.	Low Side	29	34	39	44	49	54	59	64	69	74	79
		High Side	175	181	188	194	200	206	213	219	225	231	238

Low side pressure \pm 2 PSIG (suction line between compressor and reversing valve)

High side pressure \pm 5 PSIG (liquid line @ unit quick connect)

Tables are based upon rated CFM across the evaporator coil and rated water flow rate through the water coil. If there is any doubt as to correct operating charge being in the system, the charge should be removed, system evacuated, and recharged to serial plate specifications.

TABLE 19 COOLING Water Temperature Entering Outdoor Coil Degree F

Indoor Section	Return Air Temperature	Pressure	°	°	°	°	°	°	°	°	°	°	°	°	°	°	°	°	°
			30	35	40	45	50	55	60	65	70	75	80	85	90	95	100	105	110
A36AQ-A	75 deg. DB	Low Side	53	55	57	59	61	63	64	66	67	68	69	70	71	72	73	74	75
	62 deg. WB	High Side	100	109	119	129	140	151	163	175	187	200	213	227	241	256	271	286	302
1200 CFM Rated Flow 5 GPM	80 deg. DB	Low Side	55	58	60	63	65	67	69	71	72	73	74	75	76	77	78	79	80
	67 deg. WB	High Side	103	113	123	133	144	155	167	179	192	205	219	233	247	262	278	294	310
	85 deg. DB	Low Side	60	63	65	68	70	72	74	76	77	78	80	81	82	83	84	85	86
	72 deg. WB	High Side	106	116	127	138	149	161	173	186	199	213	227	241	256	272	288	304	321
BC36B	75 deg. DB	Low Side	58	60	61	62	63	64	65	66	67	68	69	70	71	72	73	74	75
	62 deg. WB	High Side	104	112	121	132	141	152	163	175	187	200	213	227	242	257	272	288	305
1150 CFM Rated Flow 5GPM	80 deg. DB	Low Side	61	62	64	66	67	68	70	71	72	73	74	75	76	77	78	79	80
	67 deg. WB	High Side	107	116	125	135	145	156	167	179	192	205	219	233	248	263	279	296	313
	85 deg. DB	Low Side	66	68	69	71	72	73	75	76	77	78	79	80	81	82	83	84	85
	72 deg. WB	High Side	110	119	129	139	150	161	173	186	199	213	227	242	257	273	289	306	324

TABLE 20 HEATING Water Temperature Entering Outdoor Coil Degree F

Indoor Section	Return Air Temperature	Pressure	°	°	°	°	°	°	°	°	°	°	°
			30	35	40	45	50	55	60	65	70	75	80
A36AQ-A 1200 CFM Rated Flow 5 GPM	° 70 D.B.	Low Side	34	38	43	47	51	55	60	64	68	72	77
		High Side	197	204	211	218	225	232	239	246	253	260	267
BC36B 1150 CFM Rated Flow 5 GPM	° 70 D.B.	Low Side	31	36	41	45	50	55	60	64	69	74	79
		High Side	180	188	195	203	210	218	225	233	240	248	255

Low side pressure + 2 PSIG (suction line between compressor and reversing valve)

High side pressure + 5 PSIG (liquid line @ unit quick connect)

Tables are based upon rated CFM across the evaporator coil and rated water flow rate through the water coil. If there is any doubt as to correct operating charge being in the system, the charge should be removed, system evacuated, and recharged to serial plate specifications.

TABLE 21 COOLING Water Temperature Entering Outdoor Coil Degree F

Indoor Section	Return Air Temperature	Pressure	Water Temperature Entering Outdoor Coil Degree F																
			30	35	40	45	50	55	60	65	70	75	80	85	90	95	100	105	110
A36AQ-A 1450 CFM Rated Flow 6 GPM	75 deg. DB	Low Side	56	58	60	62	64	66	67	69	70	71	72	73	74	75	76	77	78
	62 deg. WB	High Side	91	101	111	122	133	145	157	169	182	195	209	224	238	254	269	285	302
	80 deg. DB	Low Side	58	61	63	66	68	70	72	74	75	76	78	79	80	81	82	83	84
	67 deg. WB	High Side	92	102	113	124	136	148	161	174	187	201	215	230	245	261	277	293	310
BC36B 1150 CFM Rated Flow 6 GPM	85 deg. DB	Low Side	62	65	68	70	73	82	77	79	81	82	84	85	86	87	88	89	90
	72 deg. WB	High Side	95	106	117	129	141	154	167	180	194	208	223	238	254	270	287	304	321
	75 deg. DB	Low Side	53	54	56	58	59	60	62	63	64	65	66	67	68	69	70	71	72
	62 deg. WB	High Side	89	98	108	118	129	140	152	164	177	190	204	218	233	248	263	279	296
BC36B 1150 CFM Rated Flow 6 GPM	80 deg. DB	Low Side	57	59	60	62	63	64	66	69	68	69	70	71	72	73	74	75	76
	67 deg. WB	High Side	89	99	110	121	132	144	156	169	182	196	210	224	239	255	271	287	304
	85 deg. DB	Low Side	62	64	65	67	68	69	71	72	73	74	75	76	77	78	79	80	81
	72 deg. WB	High Side	94	104	115	126	137	149	162	175	188	202	216	231	247	263	280	297	314

TABLE 22 HEATING Water Temperature Entering Outdoor Coil Degree F

Indoor Section	Return Air Temperature	Pressure	Water Temperature Entering Outdoor Coil Degree F										
			30	35	40	45	50	55	60	65	70	75	80
A42AQ-A 1450 CFM Rated Flow 6 GPM	70 D.B.	Low Side	32	37	42	46	51	56	61	65	70	75	80
		High Side	199	206	213	219	226	233	240	246	253	260	267
BC36B 1150 CFM Rated Flow 6 GPM	70 D.B.	Low Side	31	36	42	47	52	57	63	68	73	78	84
		High Side	197	206	215	224	233	242	251	260	269	278	287

Low side pressure + 2 PSIG (suction line between compressor and reversing valve)

High side pressure + 5 PSIG (liquid line @ unit quick connect)

Tables are based upon rated CFM across the evaporator coil and rated water flow rate through the water coil. If there is any doubt as to correct operating charge being in the system, the charge should be removed, system evacuated, and recharged to serial plate specifications.

LADDER DIAGRAM

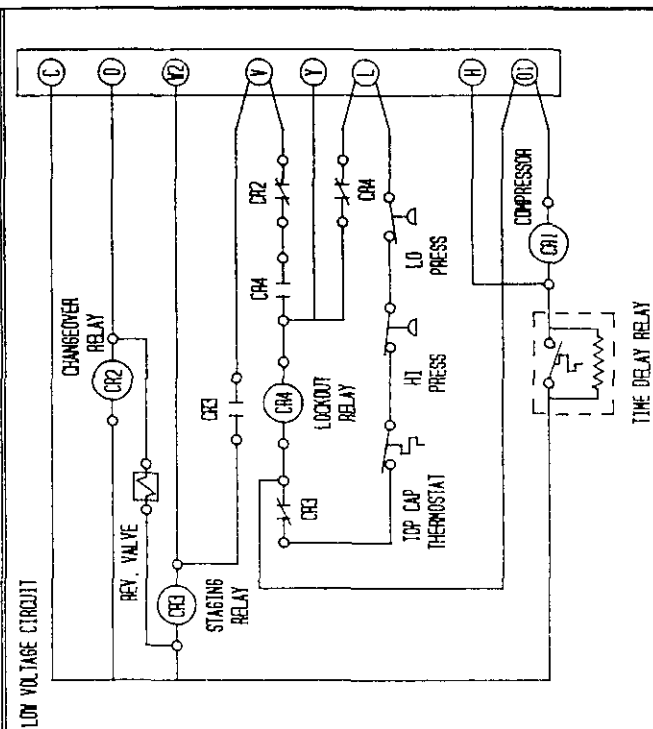
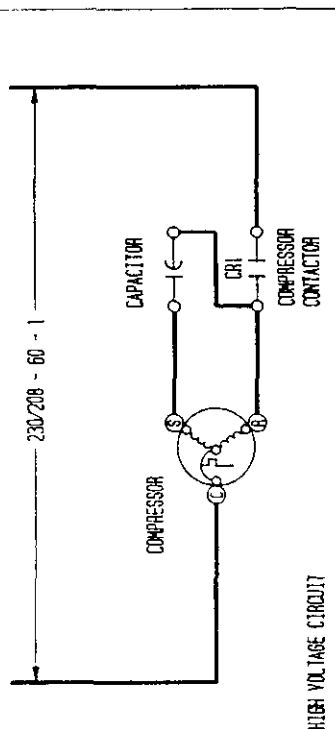

USE COPPER CONDUCTORS ONLY

4050-121 D

CONNECTION DIAGRAM

DANGER: ELECTRICAL SHOCK HAZARD.
DISCONNECT POWER BEFORE SERVICING

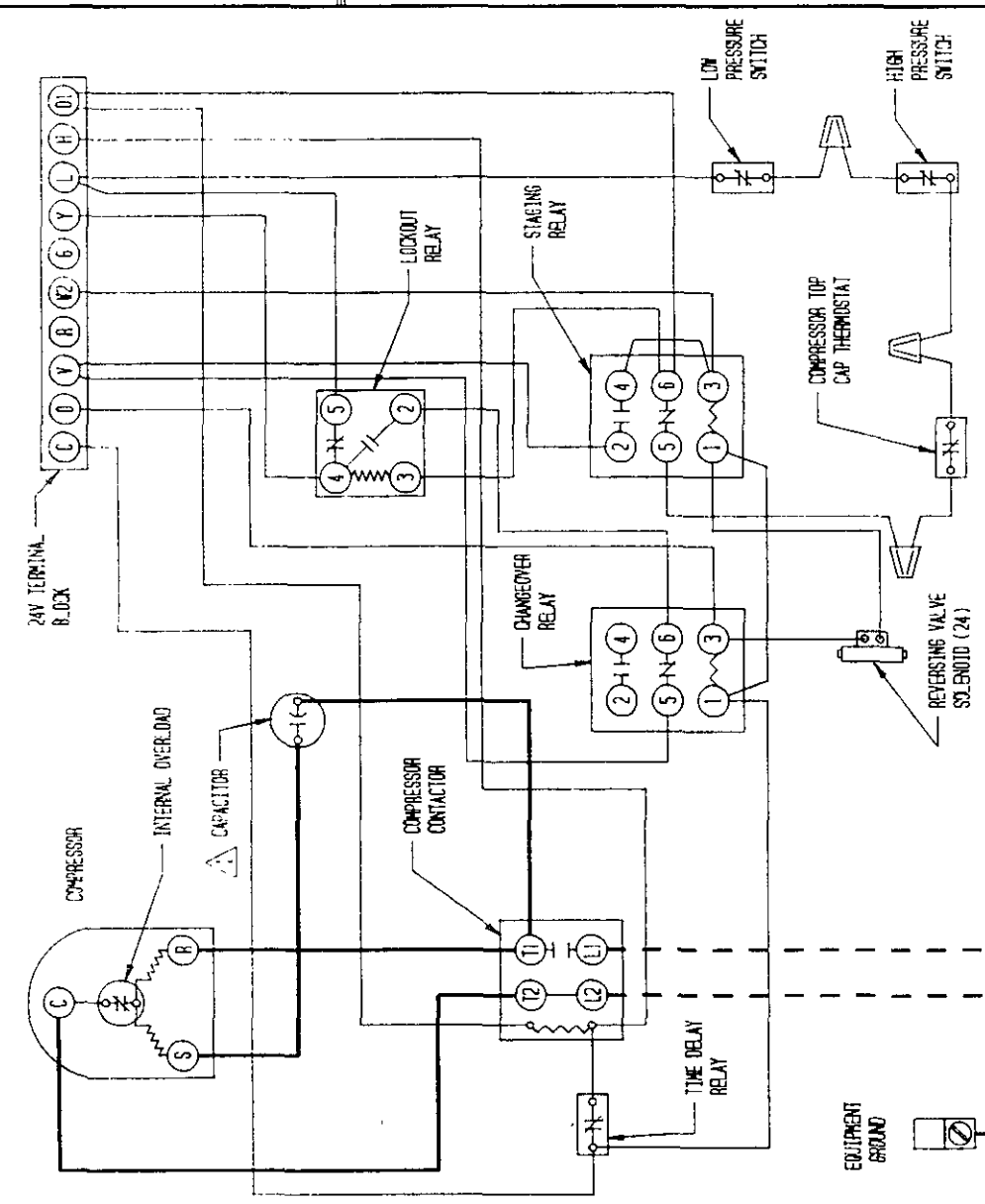

	FACTORY WIRING	FIELD WIRING
Low Voltage	---	---
High Voltage	---	---

CAPACITOR RATING	35/370	35/440
W8530A	---	---
W8536A	---	---
W8532A	---	---

230/208-60-1

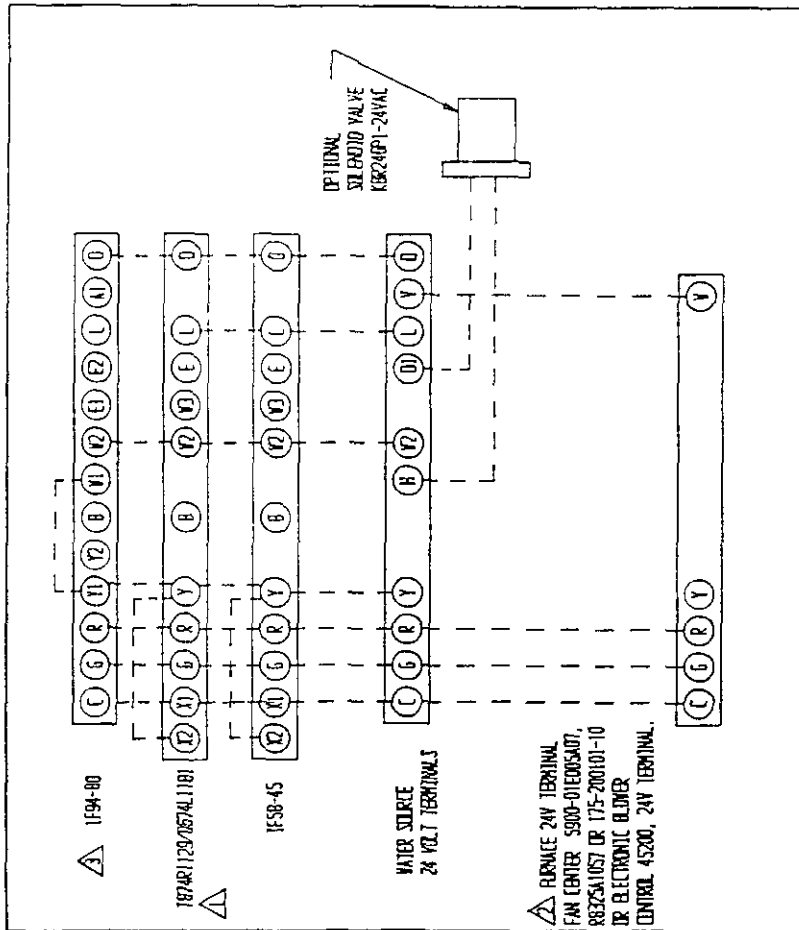

△ SET ADJUST HEAT ANTICIPATOR (SEE FURNACE INSTALLATION INSTRUCTIONS)
 △ IF THE FURNACE IS NOT INTERNALLY WIRED FOR ADD ON AIR CONDITIONING, A FAN CENTER WILL NEED TO BE ADDED.
 △ OPTION SWITCH SETTING
 SWITCH #1 'OFF'
 SWITCH #2 'OFF'
 SWITCH #3 'OFF'
 SWITCH #4 SEE THERMOSTAT INSTALLATION INSTRUCTIONS

WATER SOURCE HEAT PUMP WITH GAS FURNACE

FACTORY WIRING	FIELD WIRING
LOW VOLTAGE	---
HIGH VOLTAGE	---

LOW VOLTAGE FIELD WIRING MUST BE CLASS 1

4091-204 C

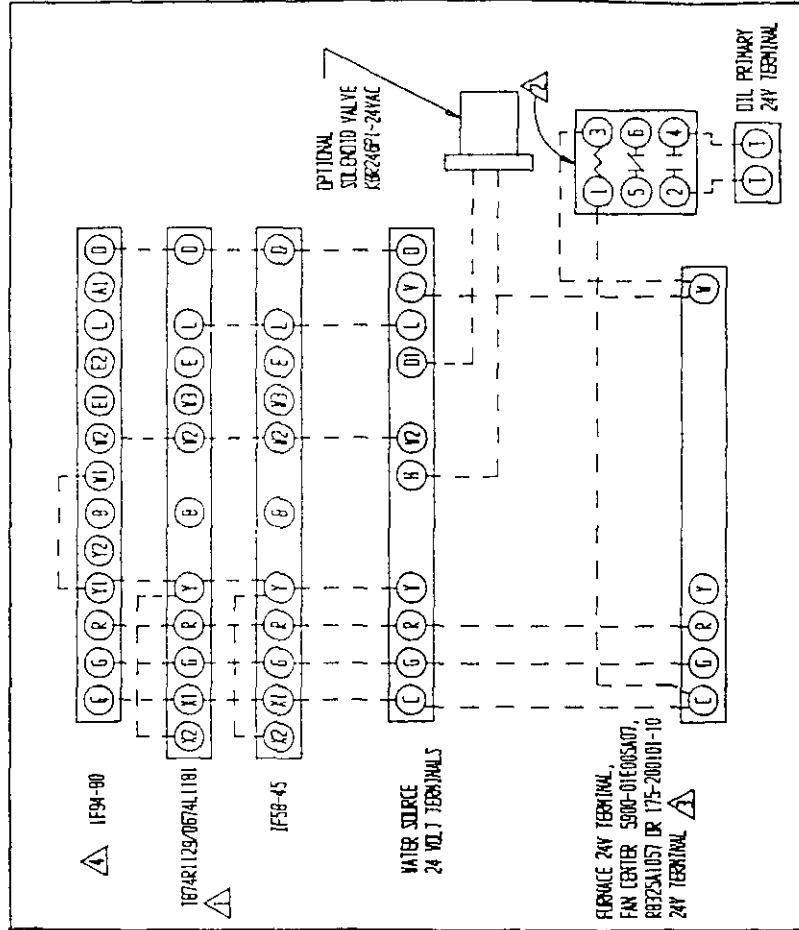

△ SET ADJUST HEAT ANTICIPATOR (SEE FURNACE INSTALLATION INSTRUCTIONS)
 △ LOCATE ISOLATING RELAY IN OIL FURNACE, NECESSARY TO SEPARATE 24V POWER SUPPLY OF HEAT PUMP FROM 24V POWER SUPPLY BUILT INTO OIL BURNER PRIMARY CONTROL.
 △ IF THE FURNACE IS NOT INTERNALLY WIRED FOR ADD ON AIR CONDITIONING, A FAN CENTER WILL NEED TO BE ADDED.
 △ OPTION SWITCH SETTING
 SWITCH #1 'OFF'
 SWITCH #2 'OFF'
 SWITCH #3 'OFF'
 SWITCH #4 SEE THERMOSTAT INSTALLATION INSTRUCTIONS

WATER SOURCE HEAT PUMP WITH OIL FURNACE

FACTORY WIRING	FIELD WIRING
LOW VOLTAGE	---
HIGH VOLTAGE	---

LOW VOLTAGE FIELD WIRING MUST BE CLASS 1

4091-205 C

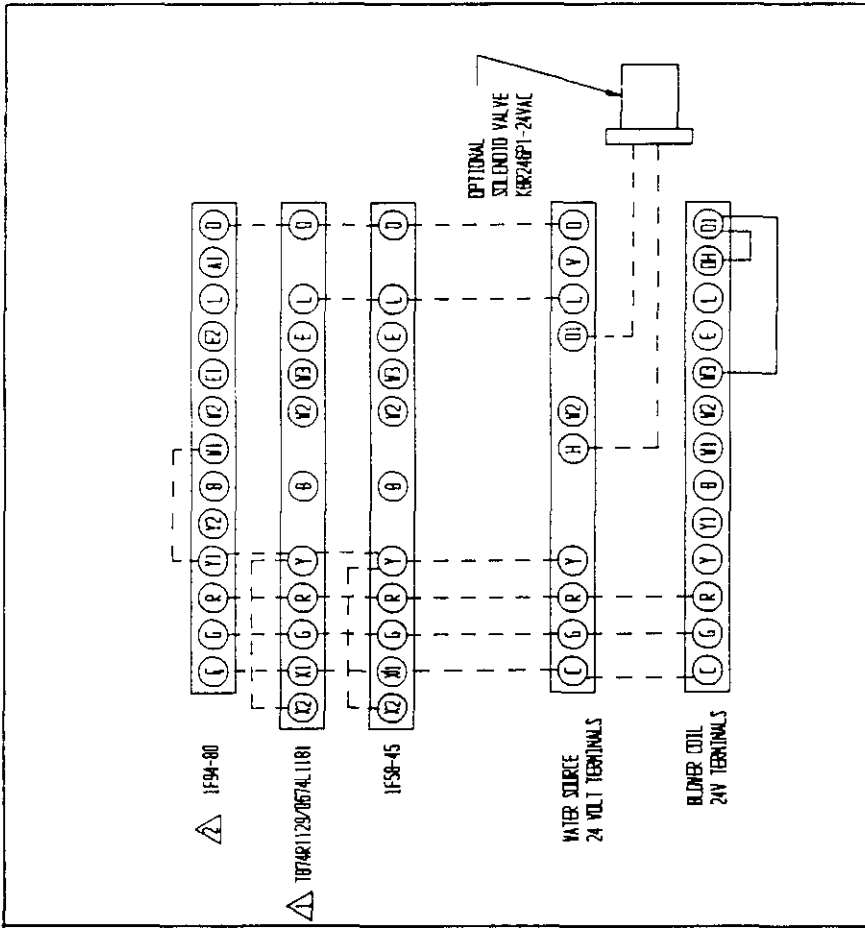

4891-405 C

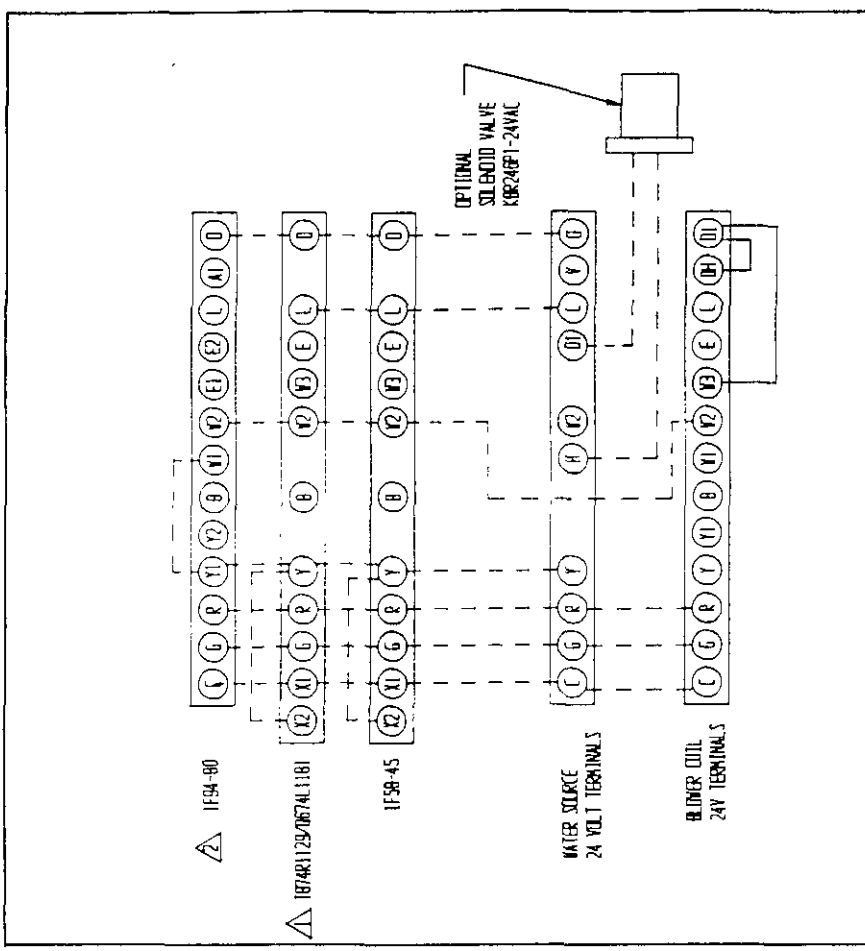

4891-406 B

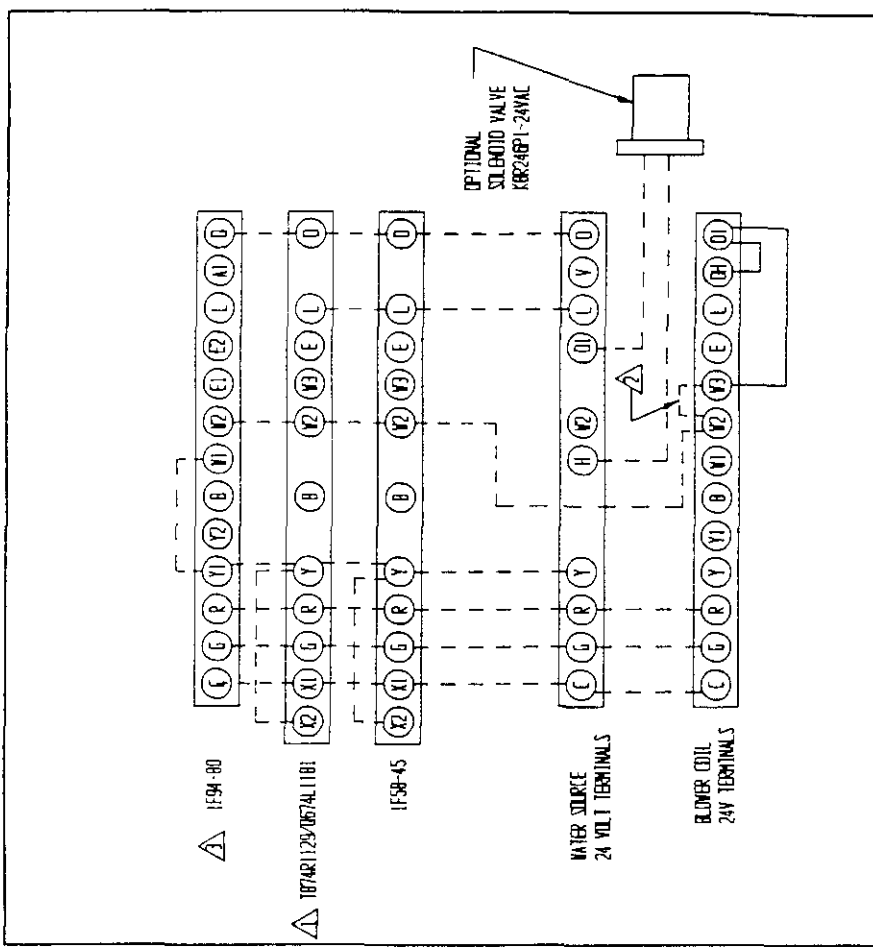
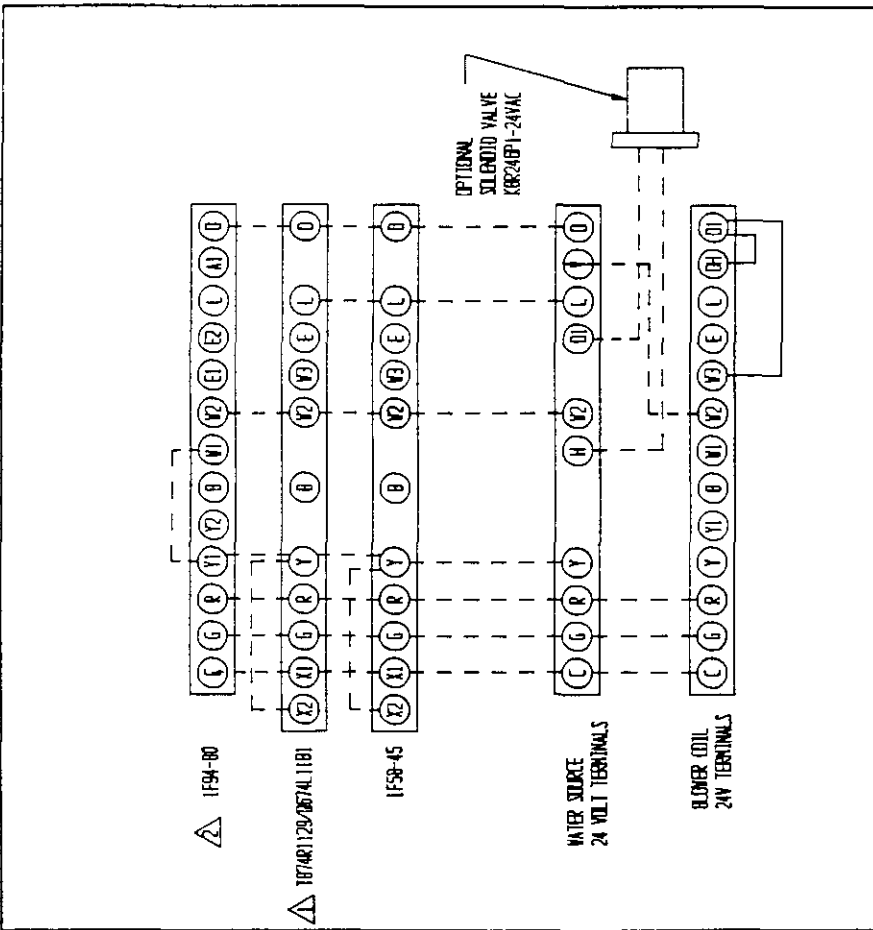

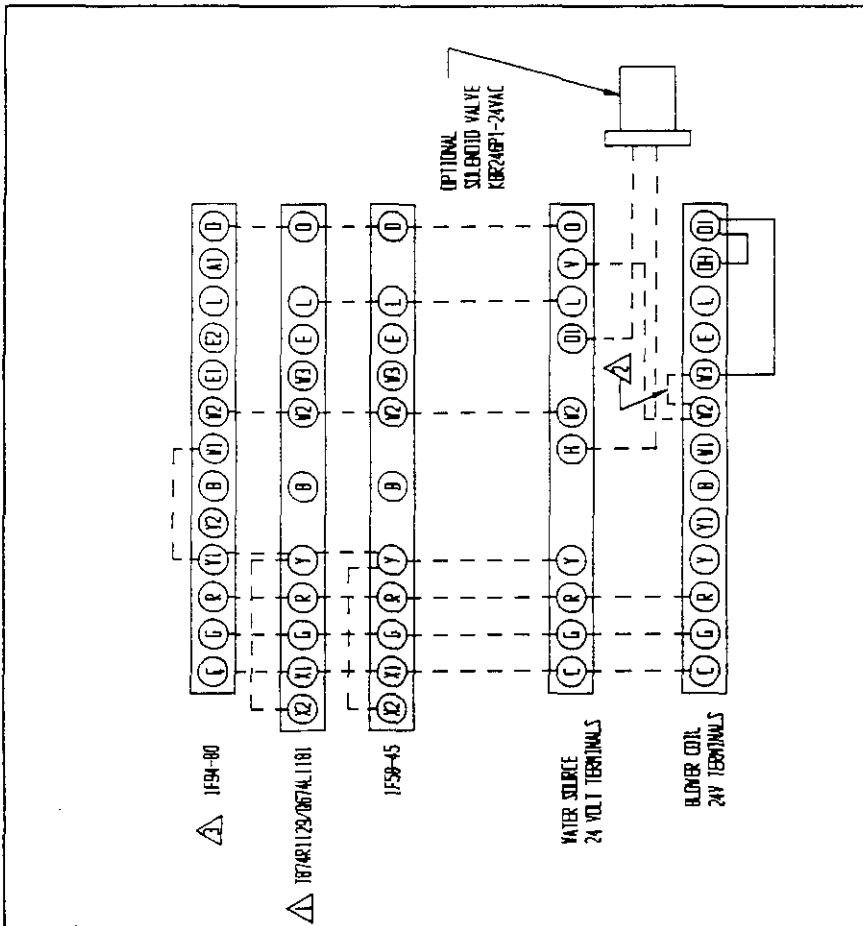

WATER SOURCE HEAT PUMP
1/4 TO 20K BLOWER COIL

OPTION SWITCH SETTING

ON	SWITCH #1 'OFF'	SWITCH #2 'OFF'	SWITCH #3 'OFF'	SWITCH #4 SEE THERMOSTAT
1	2	3	4	

LOW VOLTAGE FIELD WIRING MUST BE CLASS 1

INSTALLATION INSTRUCTIONS

FACTORY WIRING	FIELD WIRING
LOW VOLTAGE	---
HIGH VOLTAGE	---

4091-409 B

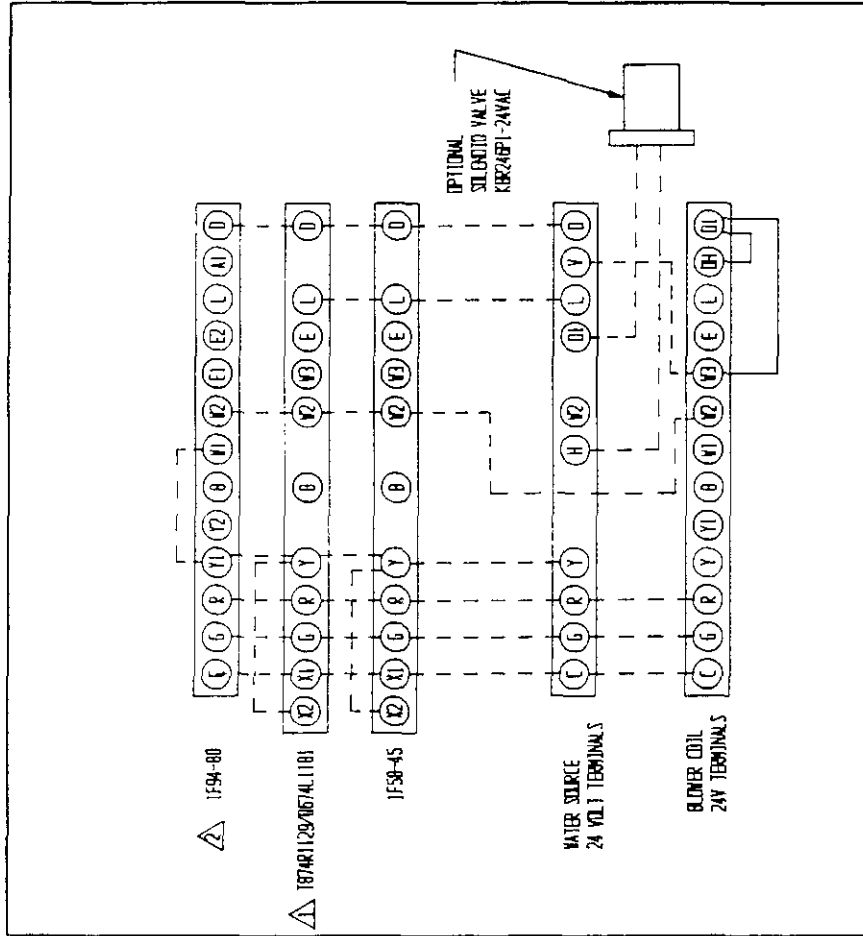

WATER SOURCE HEAT PUMP
1/4 TO 20K BLOWER COIL

OPTION SWITCH SETTING

ON	SWITCH #1 'OFF'	SWITCH #2 'OFF'	SWITCH #3 'OFF'	SWITCH #4 SEE THERMOSTAT
1	2	3	4	

LOW VOLTAGE FIELD WIRING MUST BE CLASS 1

INSTALLATION INSTRUCTIONS

FACTORY WIRING	FIELD WIRING
LOW VOLTAGE	---
HIGH VOLTAGE	---

4091-410 B

GROUND SOURCE HEAT PUMP PERFORMANCE REPORT

This performance check report should be filed out by installer and retained with unit.

DATE: _____ TAKEN BY: _____

1. OUTDOOR UNIT:
Mfgr. _____ Model No. _____ S/N _____

INDOOR UNIT (Split System):
Mfgr. _____ Model No. _____ S/N _____
2. Person Reporting _____
3. Company Reporting _____
4. Installed By _____ Date Installed _____
5. User's (Owner's) Name _____
Address _____

6. Unit Location _____

WATER SYSTEM INFORMATION

7. Open Loop System (Water Well) _____ Closed Loop System _____
A. If Open Loop where is water discharged? _____
8. The following questions are for closed loop systems only!
 - A. Closed loop system designed by _____
 - B. Type of antifreeze used _____ % Solution _____
 - C. System type _____ Series _____ Parallel _____
 - D. Pipe material _____ Nominal Size _____
 - E. Pipe installed:
 1. Horizontal _____ Total length of pipe _____ Ft
No. pipes in trench _____ Depth bottom pipe _____ ft.
 2. Vertical _____ Total length of bore hole _____ ft.

THE FOLLOWING INFORMATION IS NEEDED
TO CHECK PERFORMANCE OF UNIT.

FLUID SIDE DATA		Cooling	Heating	
9.	Entering fluid temperature	_____	_____	F
10.	Leaving fluid temperature	_____	_____	F
11.	Entering fluid pressure	_____	_____	PSIG
12.	Leaving fluid pressure	_____	_____	PSIG
13.	Pressure drop thru coil	_____	_____	PSIG
14.	Gallons per minute through the water coil	_____	GPM _____	
15.	Liquid or discharge line pressure	_____	PSIG _____	
16.	Suction line pressure	_____	PSIG _____	
17.	Voltage at compressor (unit running)	_____	_____	V
18.	Amperage draw at line side of contactor	_____	_____	A
19.	Amperage at compressor common terminal	_____	_____	A
20.	*Suction line temperature 6" from compressor	_____	_____	F
21.	*Superheat at compressor	_____	_____	F
22.	*Liquid line temperature at metering device	_____	_____	F
23.	*Coil subcooling	_____	_____	F

INDOOR SIDE DATA		Cooling	Heating	
24.	Dry bulb temperature at air entering indoor coil	_____	_____	F
25.	Web bulb temperature of air entering indoor coil	_____	_____	F
26.	Dry bulb temperature of air leaving indoor coil	_____	_____	F
27.	Wet bulb temperature of air leaving indoor coil	_____	_____	F
28.	Indoor fan motor operating voltage (split system only)	_____	_____	V
29.	Indoor fan motor operating amperage	_____	_____	A
30.	*Static pressure drop across indoor coil (split system only)	_____	WC	
31.	*Supply air static pressure (packaged unit)	_____	_____	WC
32.	*Return air static pressure (packaged unit)	_____	_____	WC
	*Items that are optional.			

30. Other information about installation

