

# **INSTALLATION INSTRUCTIONS**

## **SPLIT HEAT PUMP OUTDOOR SECTION**

### **MODELS**

**42UHPQA**

**48UHPQA**

**48UHPQA-B**

**60UHPQA**

**60UHPQA-B**

**FOR USE WITH:  
MATCHING INDOOR BLOWER  
COIL UNITS AND MATCHING  
ADD ON COIL UNITS ONLY**

MANUAL 2100-178 REV. A  
SUPERSEDES REV.  
FILE VOL. I, TAB 5

COPYRIGHT FEBRUARY, 1991  
BARD MANUFACTURING COMPANY  
BRYAN, OHIO

## TABLE OF CONTENTS

I.	Application and Location . . . . .	4
	General . . . . .	4
	Shipping Damage . . . . .	4
	Application . . . . .	4
	Location . . . . .	4
	Setting The Unit. . . . .	4
	Slab Mounting . . . . .	6
	Roof Mounting . . . . .	6
	Winter Installation Below 32 Degree F . . . . .	6
	Indoor Coil . . . . .	6
	Important Installer Note . . . . .	6
	Installing Refrigerant Tubing . . . . .	7
II.	Wiring Instructions . . . . .	9
	General . . . . .	9
	Three Phase Scroll Compressor Start Up Information. . . . .	9
	Outdoor Thermostat . . . . .	9
	Discharge Temperature (42UHPQA Only). . . . .	10
	General Operation--Heat Pump/Fossil Fuel Furnace. . . . .	11
	Note On Indoor Blower Operation . . . . .	11
	Control Circuit Wiring . . . . .	11
	Sequence of Operation When Used With Indoor Blower Coil . . . . .	16
	Thermostat Indicator Lamp . . . . .	16
	Compressor Short Cycle Protection . . . . .	16
	Defrost Cycle . . . . .	17
	Solid State Heat Pump Control Troubleshooting Procedure . . . . .	18
	Emergency Heat Position . . . . .	19
III.	Charging Instructions . . . . .	19
	Pressure Service Ports . . . . .	19
	Refrigerant Charge . . . . .	19
	Total System Charge For Split Systems . . . . .	20
IV.	Service . . . . .	22
	Service Hints . . . . .	22
	Fan Blade Setting Dimensions . . . . .	22
	Wiring Diagram . . . . .	23
	Pressure Tables . . . . .	26

FIGURES AND TABLES

Figure 1	1
Figure 2	5
Figure 3	5
Figure 4	5
Figure 5	5
Figure 6	7
Figure 7	10
Figure 8	10
Figure 9	10
Figure 10	17
Figure 11	22

Table 1	1
Table 2	2
Table 3	3
Table 4	8
Table 4A	11
Table 5	16
Table 6	19
Table 7	20
Table 8	20
Table 9	21
Table 10	26
Table 11	26
Table 12	27
Table 13	27
Table 14	28
Table 15	28

FIGURE 1

NOMENCLATURE EXPLANATION--Example:

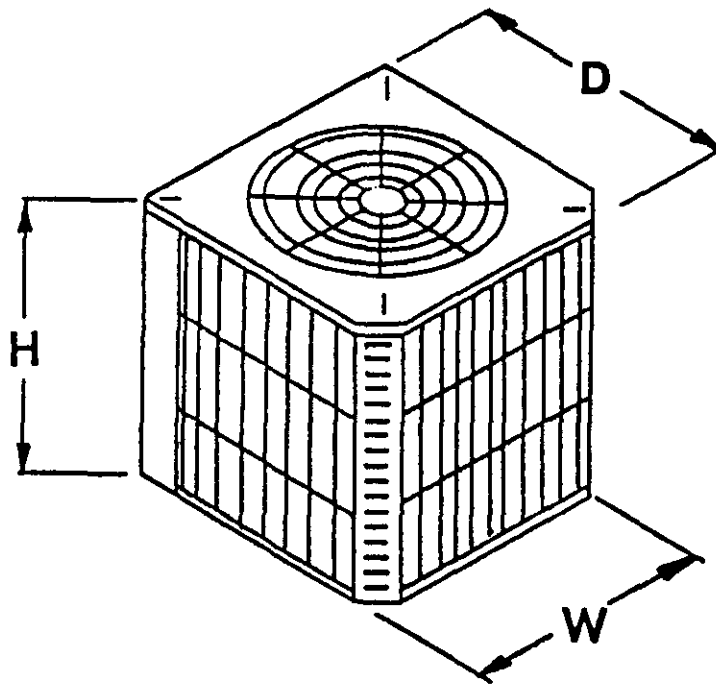
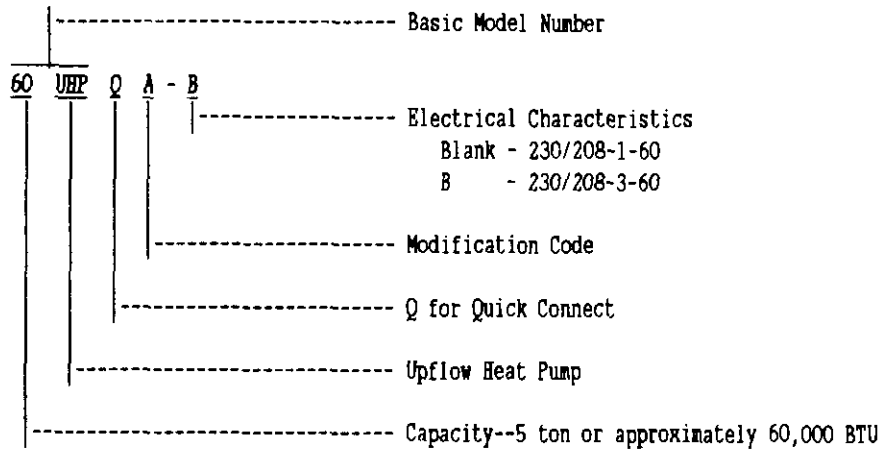

TABLE 1

DIMENSIONS			
Basic Model No.	"W" Width	"D" Depth	"H" Height
42UHPQA 48UHPQA 48UHPQA-B	32-1/2"	32-1/2"	26"
60UHPQA 60UHPQA-B	32-1/2"	32-1/2"	36"

TABLE 2

RATED CFM AND AIRFLOW DATA (Wet Coil--Cooling)							
Condensing Unit Model Number	Evaporator Coil Model Number	Rated AirFlow		Rated E.S.P. (2)	Motor Speed Tap	Recommended Air Flow Range	System Orifice Required
		CFM	Pressure Drop H <sub>2</sub> O (1)				
42UHQA	BC48B A61AQ-A	1525 1525	.20	.35	Low	1300 - 1750 1300 - 1750	.078 .078*
48UHQA 48UHQA-B	BC48B A61AQ-A	1700 1650	.25	.25	High	1450 - 1950 1400 - 1900	.078 .078*
60UHQA 60UHQA-B	BC60B A61AQ-A	1800 1800	.30	.20	High	1530 - 2050 1530 - 2050	.092 .092
<p>(1) Measured across the evaporator coil assembly, including drain pan.</p> <p>(2) External static pressure available for the duct system--supply and return. All blower coils have multi-speed motors, and value shown is at the recommended rated speed. Consult specification airflow charts with the blower coil units for complete information at other speeds.</p>							
*IMPORTANT							
<p>Proper sized orifice is not factory installed in indoor section. Proper orifice size is shipped with outdoor unit packaged with its installation instructions. The orifice must be replaced with the proper system orifice shown above.</p>							

TABLE 3  
ELECTRICAL DATA

MODEL				42УВРQA	48УВРQA	48УВРQA-B	60УВРQA	60УВРQA-B
Electrical Rating (60HZ/V/PH)				230/208-1	230/208-1	230/208-3	230/208-1	230/208-3
Operating Voltage Range				197 - 253	197 - 253	197 - 253	197 - 253	197 - 253
Minimum Circuit Ampacity				26.4	36	20.5	41	26.5
+Field Wire Size				10	8	12	6	10
++Delay Fuse Max. or Ckt. Bkr.				45	60	35	60	45
Total Unit Amps 230/208				19.3/19	25.8/28.5	16.5/16.5	28.9/33.2	21.6/21.6
COMPRESSOR								
Rated Load Amps 230/208				17.8/17.5	24.3/27	15/15	26.6/30.9	19.3/19.3
Branch Ckt. Selection Current				19.9	27	15	30.9	19.3
Lock Rotor Amps 230/208				107/107	129/129	99/99	169/169	123/123
FAN MOTOR AND COMPRESSOR								
Fan Motor--HP/RPM				1/4 - 825			1/3 - 1075	
Fan Motor--Amps				1.5			2.3	
Fan--Dia/CFM				24" - 3100			24" - 3400	
+ 60 degree C copper wire size.								
++ Maximum time delay fuse or HACR type circuit breaker.								

## I. APPLICATION AND LOCATION

### GENERAL

These instructions explain the recommended method to install the air cooled remote type outdoor unit, the interconnecting refrigerant tubing and the electrical wiring connections to the unit.

The outdoor units are to be used in conjunction with the matching indoor coils or indoor blower coil for comfort cooling/heating applications as shown in the specification sheet.

These instructions and any instructions packaged with any separate equipment required to make up the entire system should be carefully read before beginning the installation. Note particularly "Connecting Quick-Connect Couplings, Starting Procedure" and any tags and/or labels attached to the equipment.

While these instructions are intended as a general recommended guide, they do not supersede any national and/or local codes in any way. Authorities having jurisdiction should be consulted before the installation is made.

### SHIPPING DAMAGE

Upon receipt of equipment, the carton should be checked for external signs of shipping damage. If damage is found, the receiving party must contact the last carrier immediately, preferably in writing, requesting inspection by the carrier's agent.

### APPLICATION

Size of unit for a proposed installation should be based on heat loss calculation made according to methods of Air Conditioning Contractors of America. The air duct should be installed in accordance with the Standards of the National Fire Protection Association for the Installation of Air Conditioning and Ventilating Systems of Other Than Residence Type, NFPA No. 90A and Residence Type Warm Air Heating and Air Conditioning Systems, NFPA No. 90B. Where local regulations are at a variance with instructions, installer should adhere to local codes.

For applications in Canada, the installation of the system must be made in accordance with CSA Standards C22.1, Canadian Electrical Code, Part I; C273.5 Installation Requirements for Air-To-Air Heat Pumps; and B52, Mechanical Refrigeration Code.

### LOCATION

The outdoor unit is designed to be located outside with free and unobstructed outdoor coil air inlet and discharge. It must also permit access for service and installation. Outdoor air enters the coil on three sides and discharges upward from the top. Refrigerant and electrical connections are made from the rear of the unit as shown in Figure 3 with electrical service access on the right side. The unit can be installed with the rear of the unit "close to the wall", however, additional service clearance at the back of the unit would be desirable if practical for unit service. The compressor can be serviced through the top.

### SETTING THE UNIT

GENERAL--The unit must be located outside, or in a well ventilated area. It must not be in the space being heated or cooled. A sound absorbing material should be considered if the unit is to be installed in such a position or location that might cause transmission of sound or vibration to the living area or adjacent buildings.



Figure 2

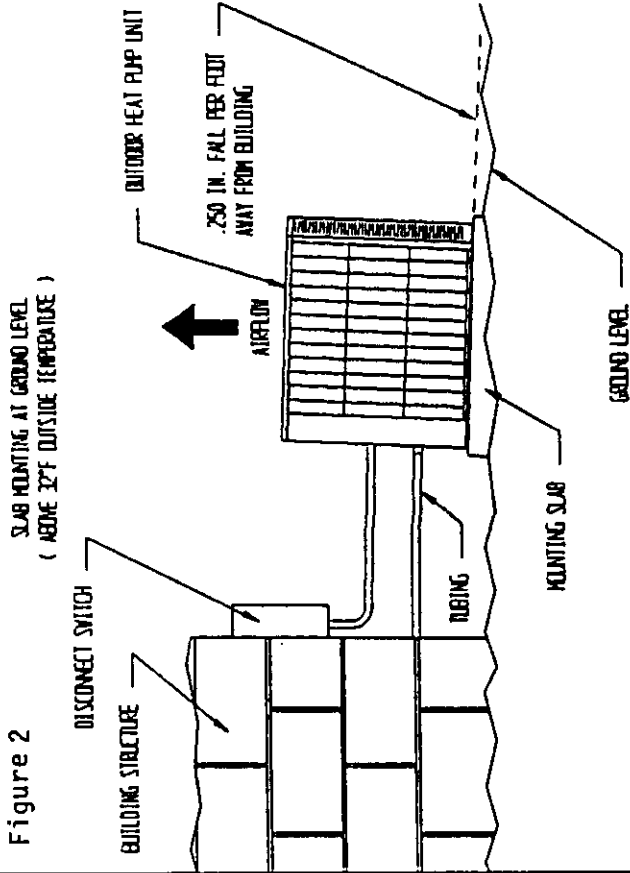

Figure 4

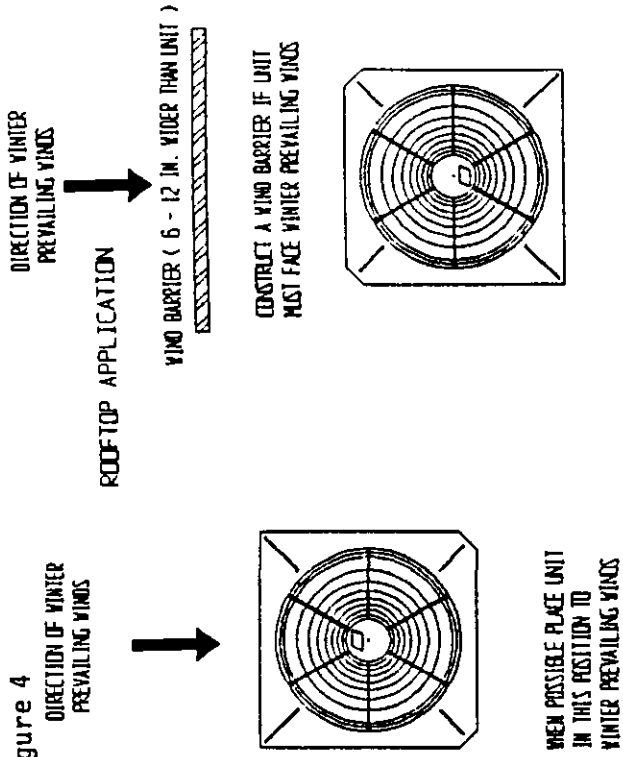

Figure 3

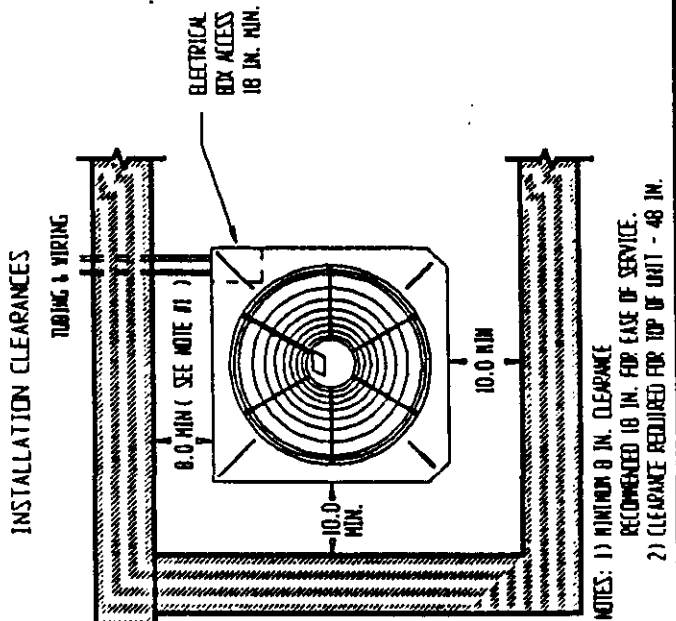
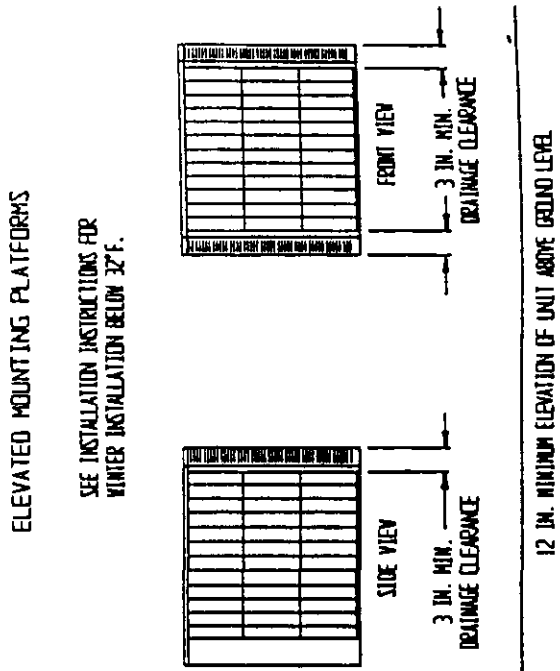

Figure 5



## SLAB MOUNTING

In areas where winter temperatures DO NOT go below 32° F for periods over twelve hours, the unit may be slab mounted at grade level. When installing the unit at grade level, install on a concrete slab at least four inches above finished grade level. Slab should have a slope tolerance away from the building structure of at least 1/4 inch per foot, while being level from side to side. This will prevent ice buildup under the unit during defrost cycles. Place slab in a location where run-off water from higher ground will not collect around unit. See Figure 2.

A minimum clearance should be provided between the coil inlet and any building surfaces. Provide at least four feet between coil outlet and any structures. Provide a minimum of 8 inches clearance on the service access side of the unit. Refer to Figure 3.

## ROOF MOUNTING

When a unit is installed in areas where low ambient temperatures or strong winter winds exist, it should be placed so prevailing winter winds are not in direct line with the heat pump coil. If this is not possible, a wind barrier should be constructed. Place barrier 24 inches from the coil side of the unit and in the direction of the prevailing winds. Size barrier at least the same height and 6 to 12 inches wider than unit. See Figure 4.

## WINTER INSTALLATION BELOW 32° F

In areas where winter conditions go below 32° F for extended periods, the unit must be elevated above the mounting surface to prevent snowfall or defrost ice accumulation from interfering with the operation of the unit. A minimum of twelve inch elevation is recommended, while greater elevation may be required for areas of high snow accumulation. For ease of installation, a heat pump stand is available from Bard. Poured concrete, steel framework, brick, cement block, etc. can be utilized to construct a suitable raised mounting platform. See Figure 5. The mounting platform must provide support on all 5 dimples located on the unit base and must not rest against the unit base.

## INDOOR COIL

These units are designed to match with all indoor blower coils, horizontal coils and "A" coils shown earlier in these instructions. Some blower and all horizontal coils are produced with capillary tube type refrigerant control. All "A" coils and some blower coils shown are produced with an interchangeable brass orifice to provide optimum matching of the refrigerant control when matching alternate sized indoor units to the outdoor unit. A properly sized orifice for each outdoor section is packaged with this unit. See installation instructions packaged with the indoor section for complete details on how to change the orifice when required. See Table 2 for proper system orifice required.

## IMPORTANT INSTALLER NOTE

For improved start-up performance, wash the indoor coil with a dishwasher detergent.

FIGURE 6

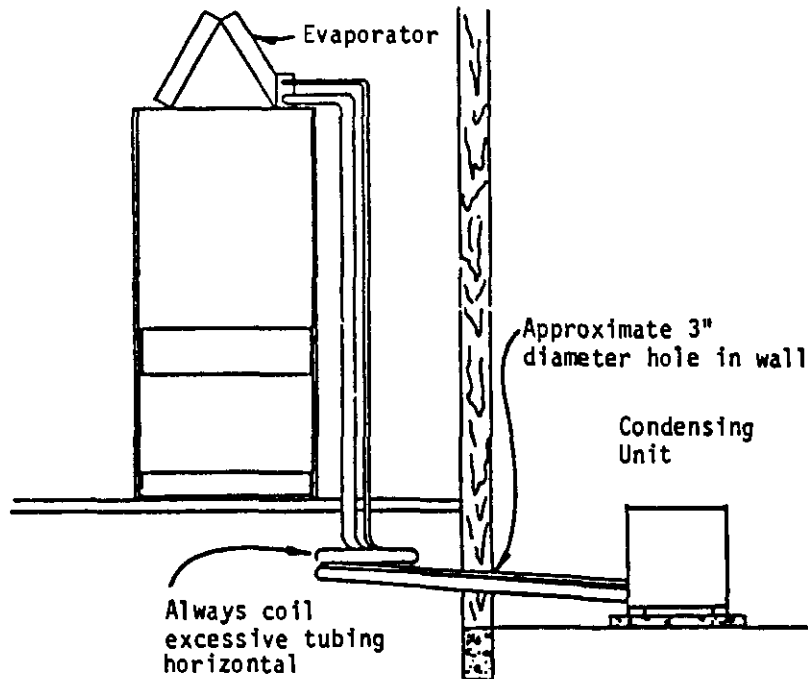

## INSTALLING REFRIGERANT TUBING

### PRECHARGED TUBING CONNECTIONS (1)

Examine carefully the two lengths of precharged tubing furnished with the system. The larger is the suction line and the smaller is the liquid line. The end of the tubing with the hex nut and gauge port is to be attached to the outdoor unit.

**STEP 1**--Unroll the tubing, being careful not to kink, and route both the suction line and liquid line between the indoor unit and outdoor unit.

Before fastening either end, use a tubing bender to make any necessary bends in tubing. When necessary to bend the insulated tube suction line, cut the insulation around its circumference at a distance far enough beyond the point of the bend so as to clear the tubing bender. Slip the insulation back together and vapor seal the joint with tape. Coil any excess tubing in a horizontal place with the slope of the tubing toward the condensing unit.

**CAUTION:** 1. Be careful not to tear the insulation when pushing it through holes in masonry or frame walls. 2. When sealing tube opening in house wall, use a soft material to prevent tube damper and vibration transmission. 3. Avoid excessive bending in any one place to avoid kinking.

**STEP 2**--Remove protector caps and plugs, inspect fittings and if necessary carefully wipe coupling seats and threaded surfaces with a clean cloth to prevent the inclusion of dirt or any foreign material in the system.

**STEP 3**--Lubricate male half diaphragm and synthetic rubber seal with refrigerant oil. Starting with the indoor coil thread coupling halves together by hand to insure proper mating of threads. Be sure to hold the coupling firmly to prevent movement of the coupling and tubing. Failure to do so could tear out the diaphragm causing a blockage of the system. Use proper size wrenches (on coupling body hex and on union nut) and tighten until coupling bodies "bottom" or a definite resistance is felt.

**CAUTION:** After starting to tighten up the fitting, never try to back it off or take it apart.

**STEP 4--**Using a marker or ink pen, mark a line lengthwise from the coupling union nut to the bulkhead. Then tighten an additional 1/4 turn: The misalignment of the line will show the amount the coupling has been tightened. This final 1/4 turn is necessary to insure the formation of leak proof joint. If a torque wrench is used, the following torque values are recommended:

TABLE 4

Coupling Size	Ft. Lbs.
-6	10 - 12
-10	35 - 45
-11	35 - 45
-12	50 - 65

Repeat Step 3 and 4 on outdoor section making sure to locate the gauge port in a 45° angle from a vertical up position so as to be accessible for gauge connections.

**STEP 5--**Leak test all connections using an electronic leak detector or a halide torch.

**STEP 6--**When tubing is installed in attics or drop ceilings, insulate the couplings on the larger tube thoroughly with 3/8" wall thickness, closed cell sponge tube insulation or equivalent. Failure to insulate will result in water damage to ceiling since the fitting will "sweat" and drop water on the ceiling.

(1) **NOTE:** The maximum distance for precharged tubing between the outdoor and indoor unit is 45 feet.

#### SWEAT STYLE TUBING CONNECTIONS

Use only refrigeration grade (dehydrated and sealed) copper tubing. Care must be taken to insure that the tubing is kept clean and dry before and during installation. Do not remove the plugs from the tubing ends, coil connections or base valves until the connection is ready to be brazed.

The suction line must be insulated with a minimum of 3/8" Armaflex or equivalent before cutting and making connections.

**STEP 1--**Being careful not to kink, route both the suction line and liquid line between the indoor unit and outdoor unit. Use a tubing bender to make any necessary bends in tubing. When necessary to bend the insulated tube suction line, cut the insulation around its circumference at a distance far enough beyond the point of the bend so as to clear the tubing bender. Slip the insulation back together and vapor seal the joint with tape. Coil any excess tubing in a horizontal place with the slope of the tubing toward the condensing unit.

**CAUTION:** 1. Be careful not to tear the insulation when pushing it through holes in masonry or framewalls. 2. When sealing tube opening in house wall, use a soft material to prevent tube damage and vibration transmission. 3. Avoid excessive bending in any one place to avoid kinking.

**STEP 2--**The tubing ends should be cut square. Make sure it is round and free of burrs at the connecting ends. Clean the tubing to prevent contaminants from entering the system.

**STEP 3--**Wrap a wet rag around the copper stub before brazing.

**STEP 4--**Flux the copper tube and insert into the stub. Braze the joint using an alloy of silver or copper and phosphorus with a melting temperature above 1100° F for copper to copper joints. The phosphorus will act as a flux, therefore, no flux will be required.

A copper-silver alloy with a high silver content should be used when iron or steel material is involved in the joint. These alloys require the use of silver solder flux. Alloys containing phosphorus should not be used with iron or steel. Phosphorus reacts with the iron, forming iron phosphate which is extremely brittle.

**CAUTION:** 1. Brazing alloys with a melting temperature below 700° F should not be used. 2. Lead-tin or tin-antimony solders should not be used due to their low melting point and necessity for corrosive fluxes.

To further prevent the formation of copper oxide inside the tubing, dry nitrogen may be purged through the refrigerant system during brazing.

\*\*\*\*\*  
**WARNING:** Never purge or pressurize a system with oxygen. An explosion and fire will result.  
\*\*\*\*\*

**STEP 5--**After brazing, quench with wet rag to cool the joint and remove any flux residue.

**STEP 6--**Leak test all connections using an electronic leak detector or a halide torch.

## II. WIRING INSTRUCTIONS

### GENERAL

All wiring must be installed in accordance with the National Electrical Code and local codes. In Canada, all wiring must be installed in accordance with the Canadian Electrical Code and in accordance with the regulations of the authorities having jurisdiction. Power supply voltage must conform to the voltage shown on the unit serial plate. A wiring diagram of the unit is attached to the inside of the electrical cover. The power supply shall be sized and fused according to the specifications supplied. A ground lug is supplied in the control compartment for equipment ground.

The control circuit is a 24 volt circuit. "Typical" wiring diagrams illustrating some of the various circuits which could be encountered can be found in the installation instructions of the indoor section.

The unit rating plate lists a "Maximum Time Delay Fuse" or "BACR Type" circuit breaker that is to be used with the equipment. The correct size must be used for proper circuit protection and also to assure that there will be no nuisance tripping due to the momentary high starting current of the compressor motor.

### THREE PHASE SCROLL COMPRESSOR START UP INFORMATION

It is important to note that unlike other 3 phase compressors the scroll compressor must be phased properly to prevent it from running backwards.

During initial start-up of 3 phase scroll compressors that are not phased properly, the compressor will run backwards with a very high noise level and high suction pressure. If the compressor is allowed to run at this condition, it will trip on the motor overloads. Short durations of this type of operation will not damage the compressor.

THE DIRECTION OF ROTATION OF THE MOTOR MAY BE CHANGED BY REVERSING ANY TWO LINE CONNECTIONS TO THE UNIT.

### OUTDOOR THERMOSTAT

Heat pump compressor operation at outdoor temperatures below 0° F are neither desirable nor advantageous in terms of efficiency. Since most equipment at time of manufacture is not designated for any specific destination of the country, and most of the equipment is installed in areas not approaching this low outdoor temperature range. An outdoor thermostat (used as a compressor cut-off) is a field installed option.

Outdoor thermostats are available to hold off various stages of electric heat or fossil fuel furnace, until needed as determined by outdoor temperature. The set point of the thermostat(s) is variable with geographic region and sizing of the heating equipment to the structure. Utilization of the Heating Application Data and the heat loss calculation of the building is required in determining the correct set points.

OUTDOOR THERMOSTAT WIRING  
FIGURE 7

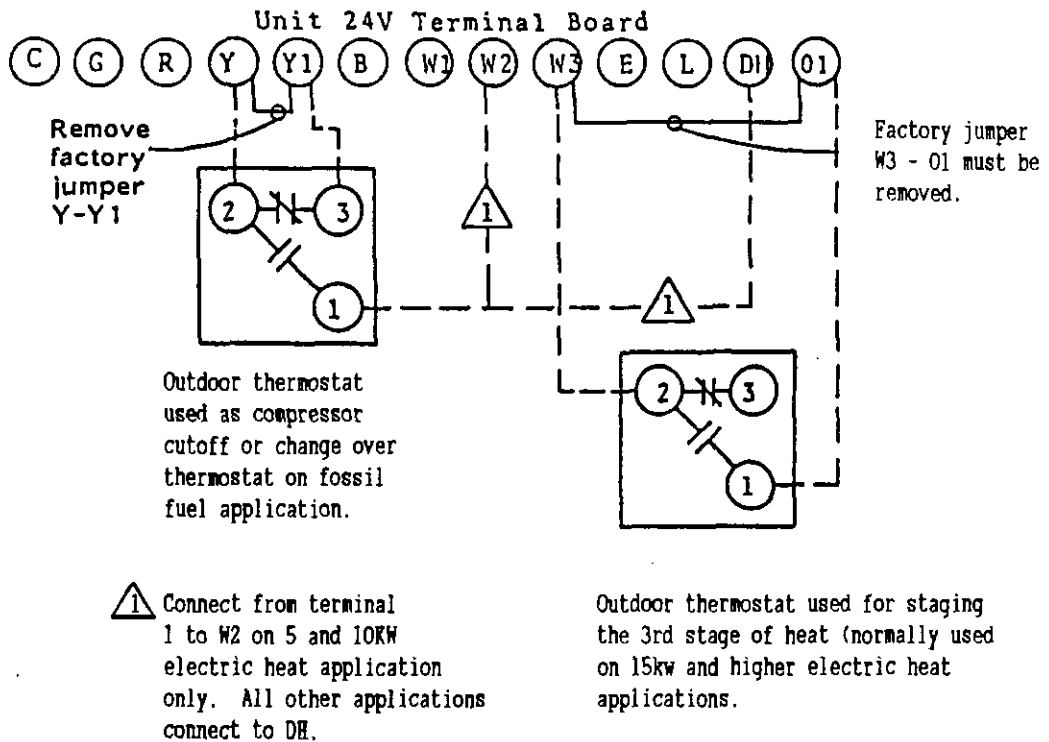

DISCHARGE TEMPERATURE (42UHPQA ONLY)

Some scroll compressors are equipped with discharge temperature sensor located on the outside top of the compressor. The sensor is a SPST thermostat which opens when the discharge temperature exceeds  $280^{\circ}\text{F} + 8^{\circ}\text{F}$  on a temperature rise. When the switch opens, the circuit to the compressor contactor is de-energized and the unit shuts off. The switch automatically resets when the compressor temperature drops below  $130^{\circ}\text{F} + 14^{\circ}\text{F}$ .

The sensor can be accessed by prying on the snap plug on top of the compressor (See Figure 8). Make sure to securely reseat the sensor after replacement. The sensor terminals are located inside the compressor terminal box. Figure 9 shows the arrangement of compressor line voltage terminals and discharge sensor terminals.

FIGURE 8

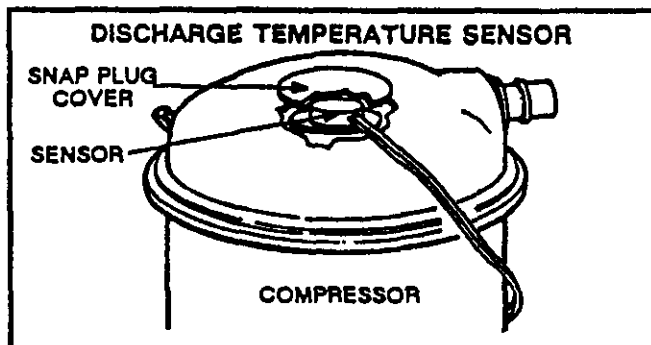
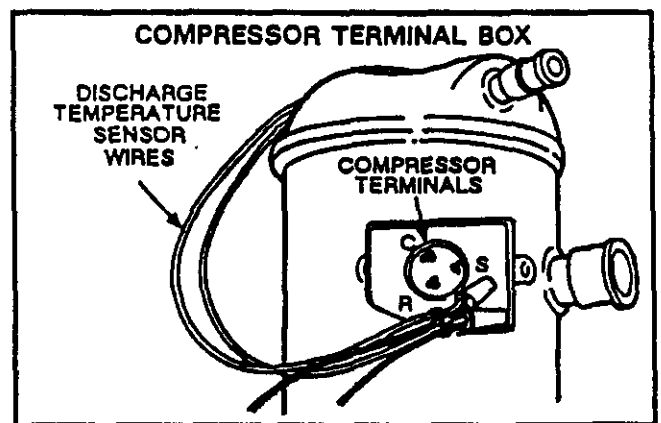

FIGURE 9



## GENERAL OPERATION--HEAT PUMP/FOSSIL FUEL FURNACE

This type of system is a one-stage heating system, even though a two-stage heat wall thermostat is used. The thermostats specified for use are special thermostats for heat pumps with extra switches, signal lights, and special circuitry for heat pumps, and by design are two-stage heating thermostats. Since the extra features are also required for the special heat pump/fossil fuel systems, the same thermostats are used, but the second stage circuit is not used. This is further explained in the next paragraph.

While it would be possible to electrically connect the furnace to the second stage of the thermostat, the heat pump coil is located downstream from the furnace heat exchanger, and continuous simultaneous operation of the furnace and heat pump will result in excessive high discharge pressures and temperatures at the compressor and resultant overload tripping problems. For this reason, the control circuit wiring diagrams shown later in this manual will not allow the furnace to operate except during defrost cycles unless an outdoor thermostat is added to the circuit. The addition of an outdoor thermostat used as a changeover thermostat will switch the system from heat pump heating to furnace heating based on the outdoor temperature. At no time will continuous operation of the heat pump and furnace be allowed.

An outdoor thermostat is used as a changeover thermostat, properly set to control at or just above the balance point, will allow the most economical operation of the system. The changeover (outdoor) thermostat switches off the heat pump and on the fossil fueled furnace, based on the outdoor temperature. There is a 5°F differential in the changeover (outdoor) thermostat, so when the heat pump is de-energized and the furnace is activated, the outdoor temperature must rise 5°F above the setpoint of the thermostat to stop the furnace and start the heat pump again. NOTE: See manual 2100-057 "Heat Pump Sizing" for procedure to determine correct balance point.

The emergency heat switch allows for manual cutoff of the heat pump and operation of the furnace at any outdoor temperature.

### NOTE ON INDOOR BLOWER OPERATION

Because of the design of the heat pump wall thermostats, and the fact that a cooling blower relay is installed in parallel with the fan side of the combination fan/limit control found on most gas or oil furnaces, the furnace blower will start as soon as the wall thermostat calls for heat. This is required for the heat pump and will also occur during the time when the heat pump is off and the furnace is operating. This is contrary to normal blower operation on a gas or oil furnace and is sometimes misunderstood, but an inherent part of the system operation. While in the gas or oil furnace mode of operation, there will still be a run-on in blower operation until the bonnet temperature cools down to the blower off setting of the fan/limit switch.

### CONTROL CIRCUIT WIRING

There are two (2) separate control diagrams for fossil fuel furnaces with heat pump.

TABLE 4A

Heat Pump System	Gas Furnace Control Diagram	Oil Furnace Control Diagram
42UEPQA	4091-200	4091-201
48UEPQA	OR	OR
60UEPQA	4091-808	4091-809

⚠ T874N1024/Q674F1261



T874R1129/Q674L1181



IF58-45



⚠

FAN CENTER 5900-01E005A07  
R8325A1057, 175-200101-10  
OR ELECTRONIC BLOWER CONTROL  
45200, 24V TERMINAL.



⚠ OUTDOOR UNIT  
24V TERMINAL

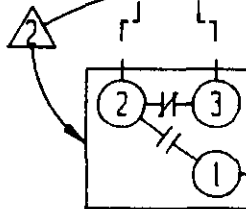
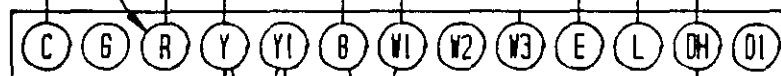

- ⚠ SET ADJUST HEAT ANTICIPATOR (SEE FURNACE INSTALLATION INSTRUCTIONS)
- ⚠ WHEN OUTDOOR THERMOSTAT (USED AS CHANGEOVER THERMOSTAT) IS INSTALLED, REMOVE JUMPER Y-Y1.
- ⚠ IF IT DESIRED NOT TO ALLOW FURNACE TO CYCLE "ON" DURING DEFROST, A 24V FACTORY WIRE RETURN (TERMINAL "3" OF DEFROST RELAY AND TERMINAL "4" ON EMERGENCY HEAT RELAY ON HPQ MODELS OR TERMINAL W2 OF HEATPUMP CONTROL AND TERMINAL DH ON TERMINAL BOARD ON UHP MODELS) MUST BE REMOVED.
- ⚠ HPQ SERIES MODEL DO NOT HAVE R TERMINAL AND IT IS NOT REQUIRED TO RUN R WIRE TO THESE MODELS.
- ⚠ IF THE FURNACE IS NOT INTERNALLY WIRED FOR ADD ON AIR CONDITIONING, A FAN CENTER WILL NEED TO BE ADDED.

**HEAT PUMP W/GAS FURNACE**

	FACTORY WIRING	FIELD WIRING
LOW VOLTAGE	_____	---
HIGH VOLTAGE	_____	---



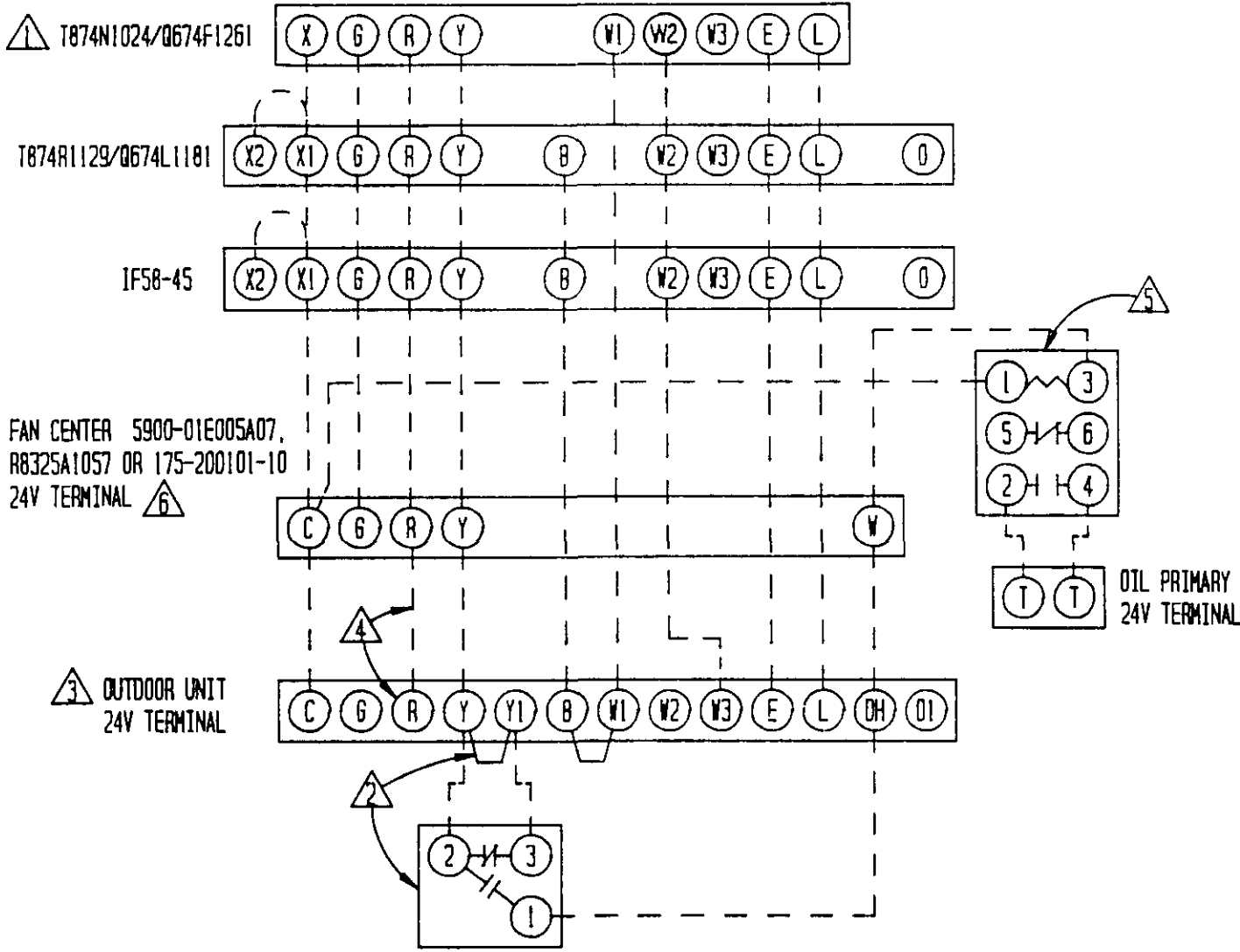



- 1 SET ADJUST HEAT ANTICIPATOR (SEE FURNACE INSTALLATION INSTRUCTIONS)
- 2 WHEN OUTDOOR THERMOSTAT (USED AS CHANGEDOVER THERMOSTAT) IS INSTALLED, REMOVE JUMPER Y-Y1.
- 3 IF IT DESIRED NOT TO ALLOW FURNACE TO CYCLE "ON" DURING DEFROST, A 24V FACTORY WIRE RETURN (TERMINAL "3" OF DEFROST RELAY AND TERMINAL "4" ON EMERGENCY HEAT RELAY ON HPQ MODELS OR TERMINAL W2 OF HEATPUMP CONTROL AND TERMINAL OH ON TERMINAL BOARD ON UHP MODELS) MUST BE REMOVED.
- 4 HPQ SERIES MODEL DO NOT HAVE (R) TERMINAL AND IT IS NOT REQUIRED TO RUN (R) WIRE TO THESE MODELS.
- 5 LOCATE ISOLATING RELAY IN OIL FURNACE. NECESSARY TO SEPARATE 24V POWER SUPPLY OF HEATPUMP FROM 24V POWER SUPPLY BUILT INTO OIL BURNER PRIMARY CONTROL.
- 6 IF THE FURNACE IS NOT INTERNALLY WIRED FOR ADD ON AIR CONDITIONING, A FAN CENTER WILL NEED TO BE ADDED.

	FACTORY WIRING	FIELD WIRING
LOW VOLTAGE	_____	-----
HIGH VOLTAGE	_____	-----

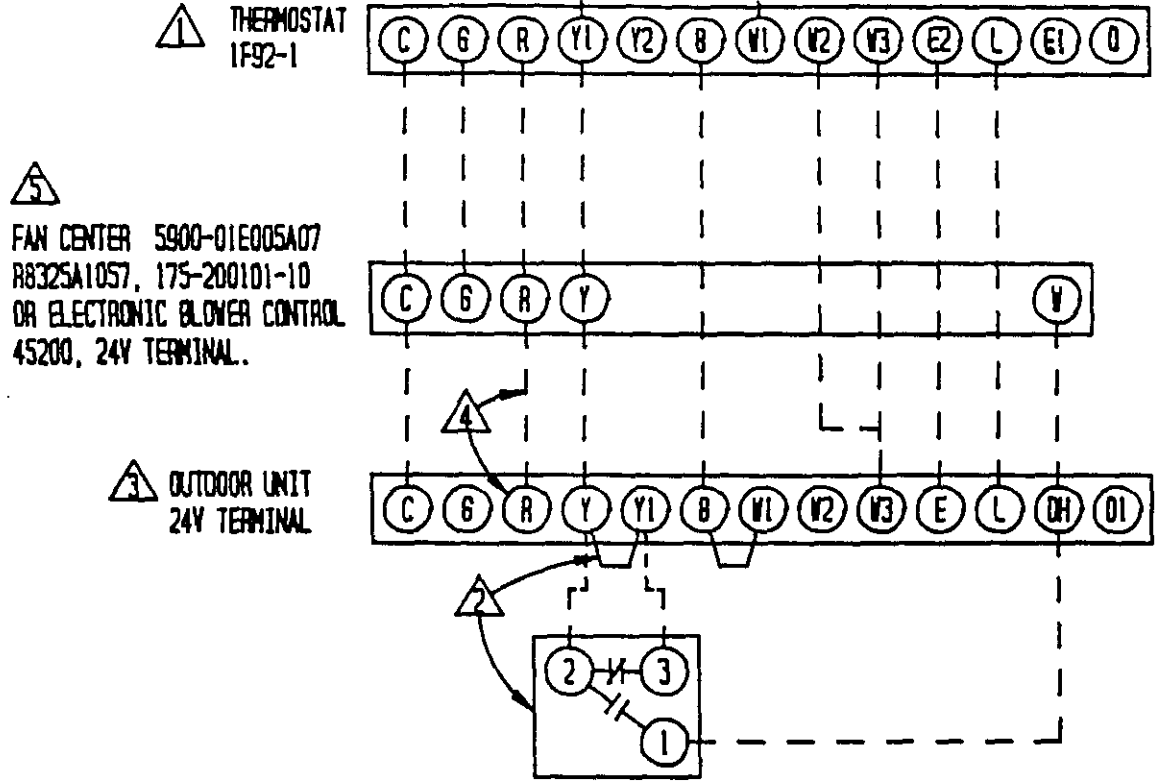
HEAT PUMP W/OIL FURNACE







**FAN CENTER** 5900-01E005A07  
 R8325A1057, 175-200101-10  
 OR ELECTRONIC BLOWER CONTROL  
 45200, 24V TERMINAL.

**OUTDOOR UNIT**  
 24V TERMINAL

 **OPTION SWITCH SETTING**



SWITCH #1 'OFF'  
 SWITCH #2 'OFF'  
 SWITCH #3 'OFF'  
 SWITCH #4 SEE THERMOSTAT  
 INSTALLATION INSTRUCTIONS

-  WHEN OUTDOOR THERMOSTATE (USED AS CHANGEOVER THERMOSTAT) IS INSTALLED, REMOVE JUMPER Y-Y1.
-  IF IT DESIRED NOT TO ALLOW FURNACE TO CYCLE 'ON' DURING DEFROST, A 24V FACTORY WIRE RETURN (TERMINAL '3' OF DEFROST RELAY AND TERMINAL '4' ON EMERGENCY HEAT RELAY ON HPQ MODELS OR TERMINAL ⑫ OF HEATPUMP CONTROL AND TERMINAL ⑪ ON TERMINAL BOARD ON UHP MODELS) MUST BE REMOVED.
-  HPQ SERIES MODEL DO NOT HAVE ⑪ TERMINAL AND IT IS NOT REQUIRED TO RUN ⑪ WIRE TO THESE MODELS.
-  IF THE FURNACE IS NOT INTERNALLY WIRED FOR ADD ON AIR CONDITIONING, A FAN CENTER WILL NEED TO BE ADDED.

**HEAT PUMP W/GAS FURNACE**

	FACTORY WIRING	FIELD WIRING
LOW VOLTAGE	_____	-----
HIGH VOLTAGE	_____	-----

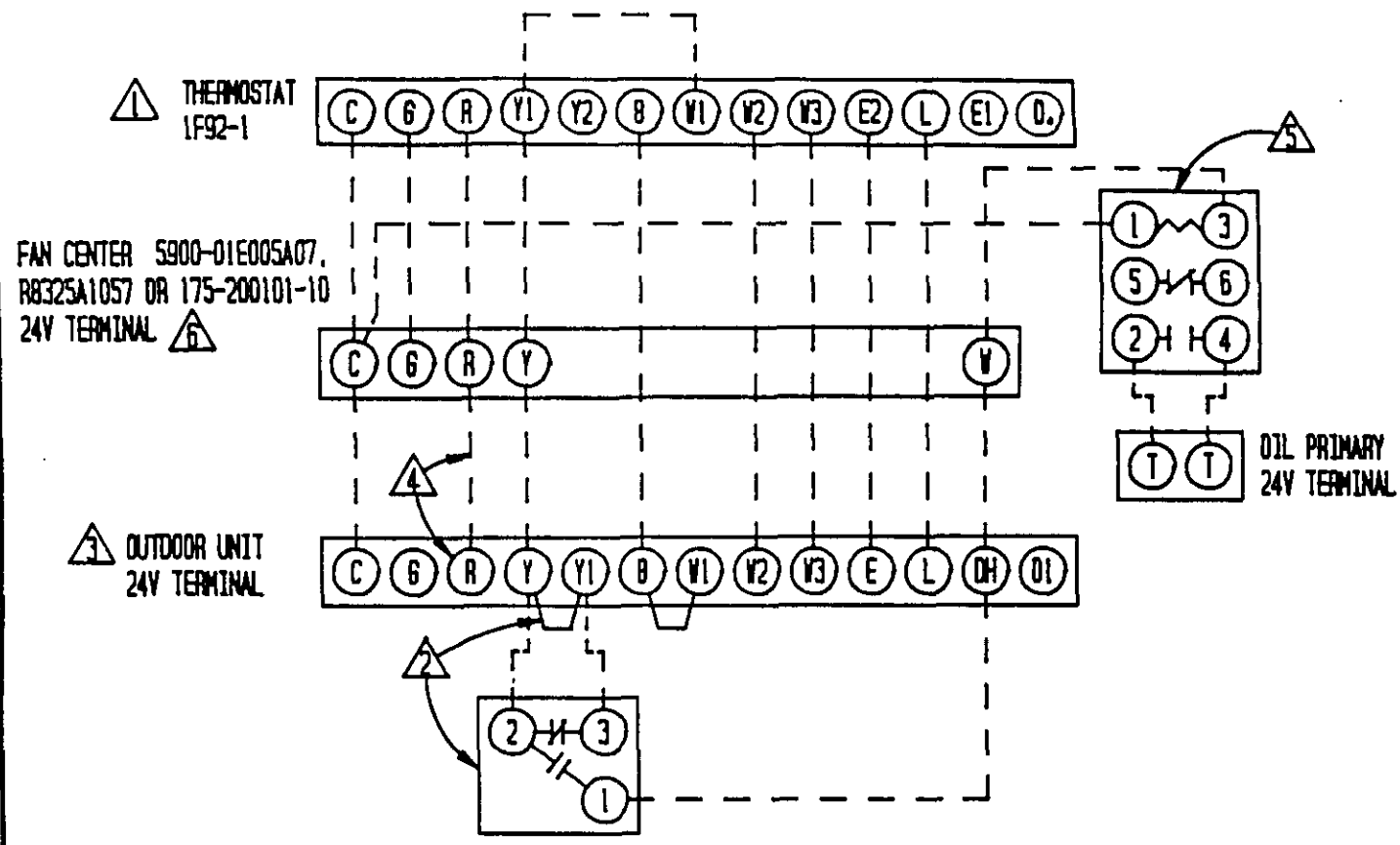

**OPTION SWITCH SETTING**

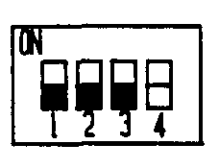

- SWITCH #1 "OFF"
- SWITCH #2 "OFF"
- SWITCH #3 "OFF"
- SWITCH #4 SEE THERMOSTAT INSTALLATION INSTRUCTIONS

- 2** WHEN OUTDOOR THERMOSTATE (USED AS CHANGEDOVER THERMOSTAT) IS INSTALLED, REMOVE JUMPER Y-Y1.
- 3** IF IT DESIRED NOT TO ALLOW FURNACE TO CYCLE "ON" DURING DEFROST, A 24V FACTORY WIRE RETURN (TERMINAL "3" OF DEFROST RELAY AND TERMINAL "4" ON EMERGENGY HEAT RELAY ON HP8 MODELS OR TERMINAL ⑫ OF HEATPUMP CONTROL AND TERMINAL ①④ ON TERMINAL BOARD ON LHP MODELS) MUST BE REMOVED.

- 4** HP8 SERIES MODEL DO NOT HAVE ⑩ TERMINAL AND IT IS NOT REQUIRED TO RUN ⑩ WIRE TO THESE MODELS.
- 5** LOCATE ISOLATING RELAY IN OIL FURNACE. NECESSARY TO SEPARATE 24V POWER SUPPLY OF HEATPUMP FROM 24V POWER SUPPLY BUILT INTO OIL BURNER PRIMARY CONTROL.
- 6** IF THE FURNACE IS NOT INTERNALLY WIRED FOR ADD ON AIR CONDITIONING, A FAN CENTER WILL NEED TO BE ADDED.

**HEAT PUMP W/OIL FURNACE**

	FACTORY WIRING	FIELD WIRING
LOW VOLTAGE	_____	-----
HIGH VOLTAGE	_____	-----

## SEQUENCE OF OPERATION WHEN USED WITH INDOOR BLOWER COIL

**COOLING**--Circuit R-Y makes at thermostat pulling in compressor contactor starting the compressor and outdoor motor. The G (indoor motor) circuit is automatically completed on any call for cooling operation, or can be energized by manual fan switch on subbase for constant air circulation.

**HEATING**--A 24V solenoid coil on reversing valve controls heating cycle operation. Two thermostat options, one allowing "Auto" changeover from cycle to cycle and the other constantly energizing solenoid coil during heating season and thus eliminating pressure equalization noise except during defrost, are to be used. On "Auto" option, a circuit is completed from R-WI and R-Y on each heating "on" cycle, energizing reversing valve solenoid and pulling in compressor contactor starting compressor and outdoor motor. R-G also make starting indoor blower motor. Heat pump heating cycle is now in operation. The second option has no "Auto" changeover position, but instead energizes the reversing valve solenoid constantly whenever the system switch on subbase is placed in "heat" position, the "B" terminal being constantly energized from R. A thermostat demand for heat completes R-Y circuit, pulling in compressor contactor starting compressor and outdoor motor. R-G also make starting indoor blower motor.

## GENERAL OPERATION--HEAT PUMP/FOSSIL FUEL FURNACE

TABLE 5

Part No.	Model No.	Description
8403-017	T874R1129	THERMOSTAT--1 stg. cool, 2 stg. heat, 1st stage fixed, 2nd stg. adj. heat anticipators
8404-009	Q674L1181	SUBBASE --System switch: Em. Heat-Heat-Off-Cool Fan switch: On-Auto SPECIAL FEATURE: Manual Changeover (Non-Cycling Rev. Valve) Em. heat light and System check light
8403-018	T874N1024	THERMOSTAT--1 stg. cool, 2 stg. heat, 1st stage fixed, 2nd stg. adj., heat anticipators
8404-010	Q674F1261	SUBBASE --System switch: Off-Cool-Auto-Heat-Em.Ht. Fan switch: On-Auto SPECIAL FEATURE: Auto system changeover, Em. heat light and System check light
8403-024	IF58-45	THERMOSTAT--1 stg. cool, 2 stg. heat, 1st stage fixed, 2nd stg. adj. heater System switch: Em. Heat-Heat-Off-Cool Fan Switch: On-Auto
8403-027	IF92-1	THERMOSTAT--2 stg. cool, 3 stg. heat, electronic SUBBASE --Manual or automatic changeover, 2 set-up/set-back periods per day, 5 or 7 day programming. CAUTION: NOT COMPATIBLE WITH UHP SERIES CONDENSERS

**IMPORTANT NOTE:** All thermostat and subbase combinations except IF92-1 shown above incorporate the following features: Man-Auto fan switch, Off-Heat-Cool-Em. Heat Switch, and two (2) indicator lamps--one for emergency heat and one for compressor malfunction.

### THERMOSTAT INDICATOR LAMPS

The red lamp marked "EM.HT." comes on and stays on whenever the system switch is placed in the emergency heat position. The green lamp marked "check" will come on if the high pressure switch opens and that prevents the compressor from running. To reset high pressure switch, place thermostat in off position then back to on position.

### COMPRESSOR SHORT CYCLE PROTECTION

The solid state heat pump control included with this model has a built in compressor short cycle protection that will prevent the compressor from restarting until compressor has been off for at least five minutes. There is a speed up jumper on the heat pump control that can be used to reduce this time for service of equipment.

## DEFROST CYCLE

The defrost cycle is controlled by time and temperature. The 24 volt solid state heat pump control runs only during heat pump operation.

When the outdoor temperature is in the lower 40° F temperature range or colder, the outdoor coil temperature is 32° F or below. This temperature is sensed by the coil sensor mounted near the bottom of the outdoor coil. The coil sensor sends a signal to the control logic of the heat pump control at approximately 32° F. Every 60 (90, or 30) minutes that the heat pump is running, contacts on the heat pump control close for 10 minutes. If the coil sensor indicates that the coil is at 32° F or lower, the defrost relay energizes and places the system in defrost mode.

during the defrost mode, the refrigerant cycle switches back to the cooling cycle, the outdoor motor stops, electric heaters are energized, and hot gas passing through the outdoor coil melts any accumulated frost. When the temperature rises to approximately 57° F, the defrost thermostat opens, de-energizing the defrost relay and returning the system to heating operations automatically.

If some abnormal or temporary condition such as a high wind causes the heat pump to have a prolonged defrost cycle, the heat pump control will restore the system to heating operation automatically after 10 minutes.

There are three settings on the heat pump control--30 minute, 60 minute, and 90 minute. Most models are shipped wired on the 60 minute setting for greatest operating economy. If special circumstances require a change to another time, remove wire connected to terminal 60 and reconnect to desired terminal.

There is a cycle speed up jumper on the control. This can be used to reduce the time between defrost cycle operation without waiting for time to elapse.

There is an initial defrost jumper on the control that can be used at any outdoor ambient during the heating cycle to simulate a 0° coil temperature. This can be used to check defrost operation of the unit without waiting for the outdoor ambient to fall into the defrost region.

FIGURE 10

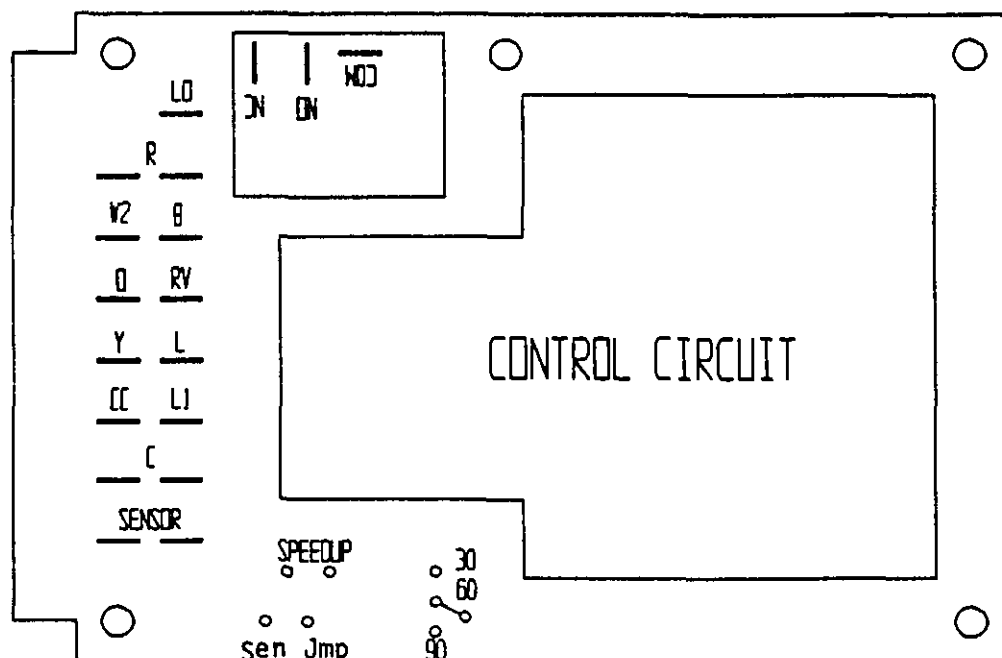

## SOLID STATE HEAT PUMP CONTROL TROUBLESHOOTING PROCEDURE

1. Turn on AC power supply to indoor and outdoor units.
2. Turn thermostat blower switch to fan on--The indoor blower should start. (If it doesn't, troubleshoot indoor unit and correct problem).
3. Turn thermostat blower switch to auto position. Indoor blower should stop.
4. Set system switch to heat or cool. Adjust thermostat to call for heat or cool--The indoor blower, compressor, and outdoor fan should start.

**NOTE:** If there was no power to 24 volt transformer, the compressor and outdoor fan motor will not start for 5 minutes. This is because of the compressor short cycle protection.

Symptom	Possible Causes	What to Check	How To Check Or Repair
Compressor contactor does not energize (cooling or heating)	Control circuit wiring	Check for R connection at outdoor unit, and 24V between R-C.	Run R connection to outdoor unit to power heat pump control.
	Compressor lock out	1. Check for 24V between L1-C on heat pump control. 2. Check across high pressure switch.	1. If no voltage between L1-C turn thermostat off and on again to reset high pressure switch. 2. If high pressure switch is open and will not reset, replace high pressure switch.
	Compressor short cycle protection	Check for 24V between CC-C on heat pump control.	1. If no voltage between CC-C jumper speed up terminal and within 10 seconds power should appear between CC-C. Remove speed up jumper after 10 seconds.
	Heat pump control defective	Check all other possible causes. Manual 2100-065	Replace heat pump control.
	Contactor defective	Check for open or shorted coil winding.	Replace contactor.
Fan outdoor motor does not run (cooling or heating except during defrost)	Motor defective	Check for open or shorted motor winding	Replace motor.
	Motor capacitor defective	Check capacitor rating. Check for open or shorted capacitor.	Replace capacitor.
	Heat pump control defective	Check across fan relay on heat pump control, (Com-NC)	Replace heat pump control.
Reversing valve does not energize (heating only)	Reversing valve solenoid coil defective	Check for open or shorted coil.	Replace solenoid coil.
	Heat pump control defective	Check for 24V between RV-C and B-C.	1. Check control circuit wiring. 2. Replace heat pump control.
Unit will not go into defrost (heating only)	Temperature sensor or heat pump control defective	Disconnect temperature sensor from board and jumper across speed up terminals andsen jmp terminals. This should cause the unit to go through a defrost cycle within one minute.	1. If unit goes through defrost cycle, replace temperature sensor. 2. If unit does not go through defrost cycle, replace heat pump control.
Unit will not come out of defrost (heating only)	Temperature sensor or heat pump control defective	Jumper across speed up terminals. This should cause the unit to come out of defrost within one minute.	1. If unit comes out of defrost cycle, replace temperature sensor. 2. If unit does not come out of defrost cycle, replace heat pump control.

## EMERGENCY HEAT POSITION

The operator of the equipment must manually place the system switch in this position. This is done when there is a known problem with the outdoor section, or when the green "check" lamp comes on indicating a problem.

## III. CHARGING INSTRUCTIONS

### PRESSURE SERVICE PORTS

High and low pressure service ports are installed on all units so that the system operating pressures can be observed. Pressure tables can be found later in the manual covering all models. It is imperative to match the correct pressure table to the unit by model number.

The pressure service ports on the split system heat pump are located on the interconnecting tubing quick connect fittings. An additional low side service port is located on the quick connect mounting plate for low side pressure during heating operation.

### REFRIGERANT CHARGE

The correct system R-22 is shown on the unit rating plate. Optimum unit performance will occur with a refrigerant charge resulting in a suction line temperature (6" from compressor) as shown in the following table:

TABLE 6

Models	Rated Airflow	95 Degrees F O.D. Temp.	82 Degrees F O.D. Temp
42UHPQA/BC48B 42UHPQA/A61AQ-A 48UHPQA/BC48B 48UHPQA/A61AQ-A	1525 1525 1700 1650	56 - 58 57 - 59 55 - 57 54 - 56	68 - 70 68 - 70 67 - 69 68 - 70
60UHPQA/BC36B 60UHPQA/A61AQ-A	1800 1800	53 - 55 52 - 54	58 - 60 61 - 63

**NOTE:** The suction line temperatures are based upon 80° F dry bulb/67° F wet bulb (50% R.H.) temperature and rated air flow across the indoor coil during cooling cycle.

## TOTAL SYSTEM CHARGE FOR SPLIT SYSTEMS

The following tables are used to determine the operating charge for split air conditioning and heat pump systems. The values shown are the total amount of refrigerant received in the precharged system components, which include the outdoor unit, indoor unit, and inter-connecting tubing. This is also the amount of refrigerant required for a system recharge following any refrigeration system repairs.

Find the outdoor section and matching indoor section (Table 8) and connecting tubing set (Table 7) for system being used. Add the ounces of charge for each of the system components together. This value is the TOTAL SYSTEM CHARGE.

$$\begin{array}{r} \text{OZs} \\ \hline \text{OUTDOOR UNIT} \\ \text{(Table 8)} \end{array} + \begin{array}{r} \text{OZs} \\ \hline \text{INDOOR UNIT} \\ \text{(Table 8)} \end{array} + \begin{array}{r} \text{OZs} \\ \hline \text{TUBING SET} \\ \text{(Table 7)} \end{array} = \begin{array}{r} \text{OZs} \\ \hline \text{TOTAL SYSTEM CHARGE} \end{array}$$

To change total charge to lbs. and ozs., divide by 16.

EXAMPLE: 60UHPOA with BC60B and CT25-12 tubing set.

$$\begin{array}{r} 214 \\ \hline \end{array} \text{ OZs} + \begin{array}{r} 10 \\ \hline \end{array} \text{ OZs} + \begin{array}{r} 8 \\ \hline \end{array} \text{ OZs} = \begin{array}{r} 232 \\ \hline \end{array} \text{ OZs}$$

or  $\frac{232}{16} = 14 \text{ lbs. } 8 \text{ ozs.}$

TABLE 7

CHARGED TUBING SETS				
Model	Charge	Length in Ft.	Liquid Line	Suction Line
FOR USE WITH:				
CT0	None*	0	3/8"	3/4"
CT15A	2 oz.	15	3/8"	7/8"
CT25A	8 oz.	25	3/8"	3/4"
CT35	14 oz.	35	3/8"	3/4"
CT45	20 oz.	45	3/8"	3/4"
FOR USE WITH: 42UHPOA, 48UHPOA, 60UHPOA				
CT0	None*	0	3/8"	7/8"
CT15A	2 oz.	15	3/8"	7/8"
CT25A	8 oz.	25	3/8"	7/8"
CT35	14 oz.	35	3/8"	7/8"
CT45	20 oz.	45	3/8"	7/8"

\*CT0 and CTO-12 for field installed tubing. (See Table 8 for charging).

TABLE 8

Model	Outdoor Unit Factory Charge	For Use With Indoor Unit	Indoor Unit Factory Charge
42UHPOA	170 oz.	BC48B A61AQ-A	2 oz. 8 oz.
48UHPOA	190 oz.	BC48B A61AQ-A	2 oz. 8 oz.
60UHPOA	214 oz.	BC60B A61AQ-A	10 oz. 8 oz.



In the event that the installer is running his own tubing by using a CTO kit, or is modifying a precharged tubing set by adding or subtracting a few feet of tubing length, the tubing set should be evacuated and charged before being connected to the outdoor and indoor section. In the event that a sweat type indoor coil is being installed, braze the line set to the indoor coil and evacuate both coil and line set prior to connecting to outdoor unit.

#### APPLICATION GUIDELINES

To determine a total system charge for a system that is connected with a non-standard tubing length, the outdoor basic charge (from Table 8) plus the indoor basic unit charge (from Table 8) is added to the tubing charge adjustment (rounded to next higher full ounce) based on liquid line size. This value is the total system charge.

EXAMPLE: 60UHPOA with BC60B and 45 feet 3/8" O.D liquid line

$$\underline{200} + \underline{24} + \underline{(.6 \times 45) 27 \text{ oz.}} = \underline{251}$$

$$\text{OR } \frac{251}{16} = 15 \text{ lbs. } 11 \text{ oz.}$$

Application guidelines: For tubing sizes up to 45 feet, use liquid line size and suction line size as shown for precharged tubing sets. For tubing sizes for remote systems between 46 feet and 100 feet in length. Use size recommended in below table based on the 25 foot charged tubing size shown in Table 7.

TABLE 9

Approved 25 Feet Charged Tubing Sizes		Tubing Size Recommended (1)			
		45 - 75 Ft.		76 - 100 Ft.	
Liquid	Vapor	Liquid	Vapor	Liquid	Vapor
1/4"	5/8"	1/4"	3/4"	3/8"	3/4"
1/4"	3/4"	1/4"	7/8"	3/8"	7/8"
3/8"	3/4"	3/8"	7/8"	1/2"	7/8"
3/8"	7/8"	3/8"	7/8"	1/2"	1-1/8"

The basis for selection is to maintain adequate velocity which assures adequate oil return to the compressor, an acceptable pressure drop to assure compressor capacity, and minimum tubing costs.

- (1) These recommendations are based on the use of standard refrigeration tubing.
- (1) Line sizes listed are outside tube dimensions.
- (1) These suggestions do not include consideration for additional pressure drop due to elbows, valves, or reduced joint sizes.
- (1) These recommendations are to be applied to approved combinations of Bard outdoor and indoor sections only.

Charge adjustments for tubing sizes are as follows (2):

1/4" liquid line	.2 oz. R-22 per foot
3/8" liquid line	.6 oz. R-22 per foot
1/2" liquid line	1.2 oz. R-22 per foot

- (2) These values should only be applied during initial system charging. System operating charge should be adjusted for optimum performance outlined in the installation instructions for that model outdoor section.

### III. SERVICE

#### SERVICE HINTS

1. Caution homeowner to maintain clean air filters at all times. Also, not to needlessly close off supply and return air registers. This reduces air flow through the system, which shortens equipment service life as well as increasing operating costs.
2. Switching to heating cycle at 75° F or higher outside temperature may cause a nuisance trip of the reset high pressure switch.
3. The heat pump wall thermostats perform multiple functions. Be sure that all function switches are correctly set for the desired operating mode before trying to diagnose any reported service problems.
4. Check all power fuses or circuit breakers to be sure that they are the correct rating.
5. Periodic cleaning of the outdoor coil to permit full and unrestricted air flow circulation is essential.

#### FAN BLADE SETTING DIMENSIONS

Shown in the drawing below are the correct fan blade setting dimensions for proper air delivery across the outdoor coil.

Any service work requiring removal or adjustment in the fan and/or motor area will require that the dimensions below be checked and blade adjusted in or out on the motor shaft accordingly.

FIGURE 11

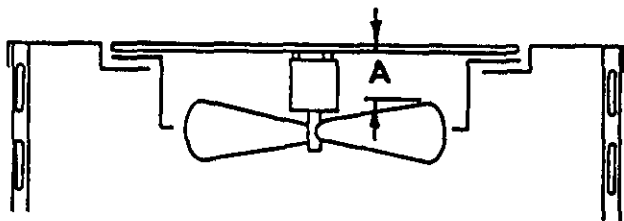

Model	Dimension A (Inches)
42UHPQA 48UHPQA 60UHPQA	4

**CONNECTION DIAGRAM**  
**DANGER: ELECTRICAL SHOCK HAZARD.**  
**DISCONNECT POWER BEFORE SERVICING**

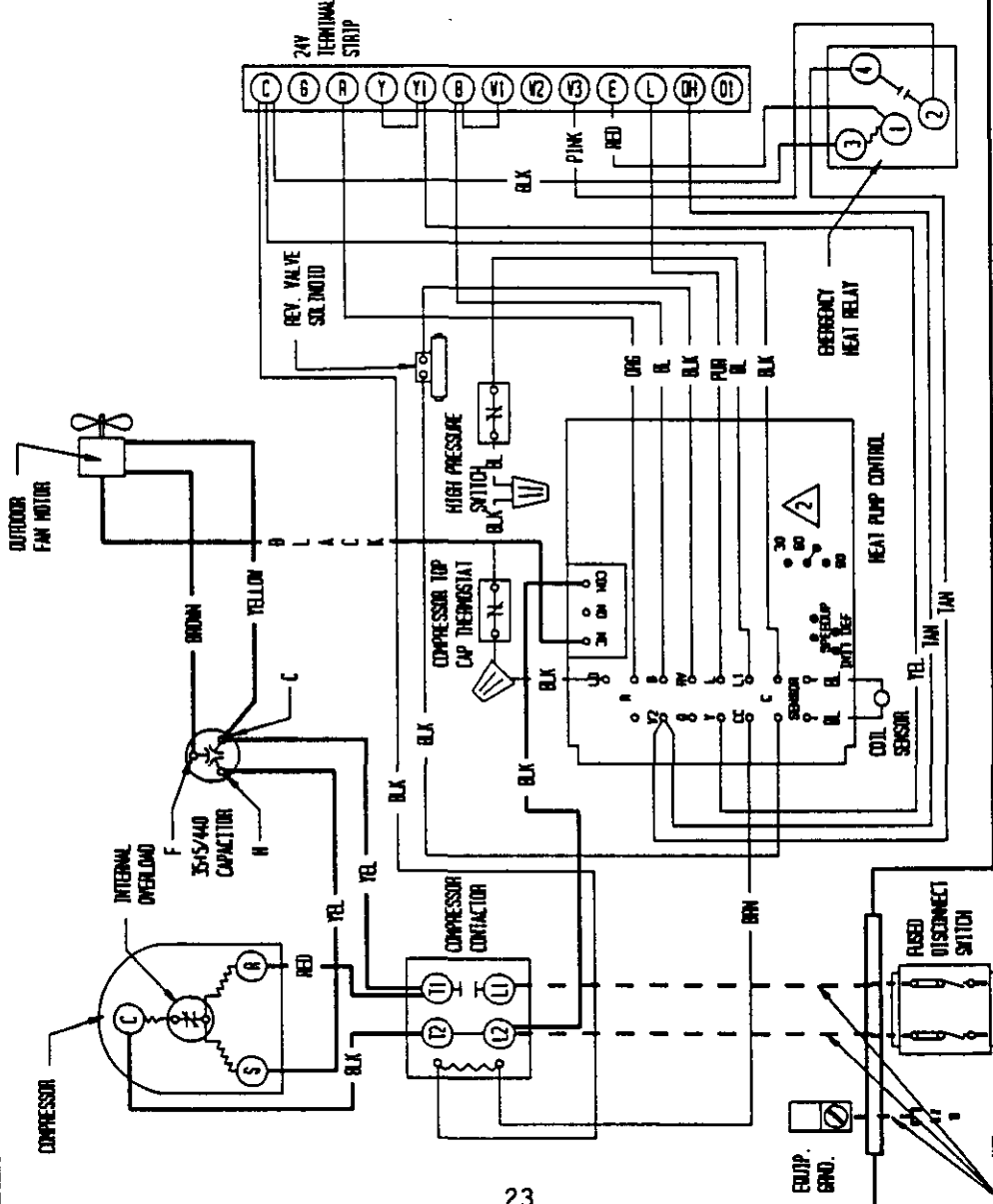

Low Voltage  
 High Voltage

FACTORY WIRING  
 FIELD WIRING

FACTORY SET ON 60 MIN. CYCLE  
 RECONNECT TO 30 FOR 30 MIN. CYCLE  
 RECONNECT TO 90 FOR 90 MIN. CYCLE

**LADDER DIAGRAM**

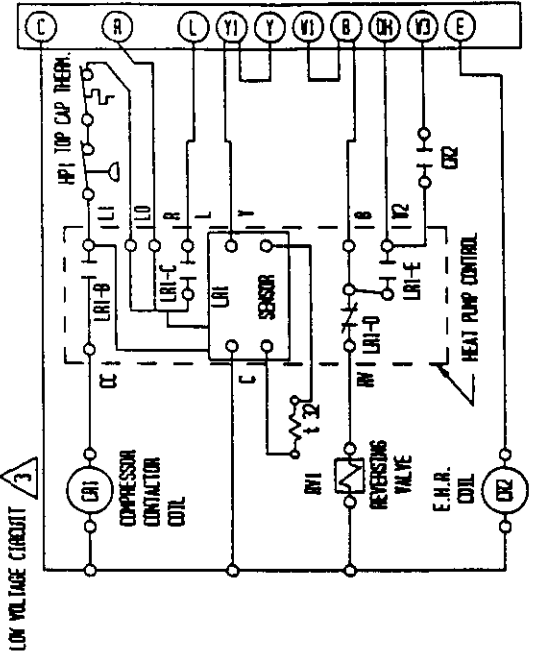
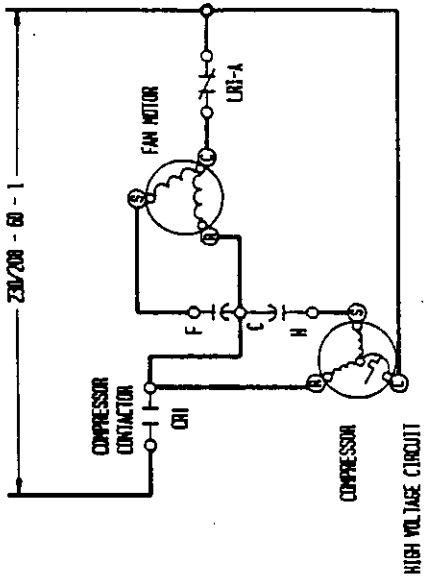

△ 24 VOLTS FOR LOW VOLTAGE CONTROL CIRCUIT SUPPLIED BY INDOOR UNIT TRANSFORMER

**CONNECTION DIAGRAM**  
**DANGER: ELECTRICAL SHOCK HAZARD.**  
**DISCONNECT POWER BEFORE SERVICING**

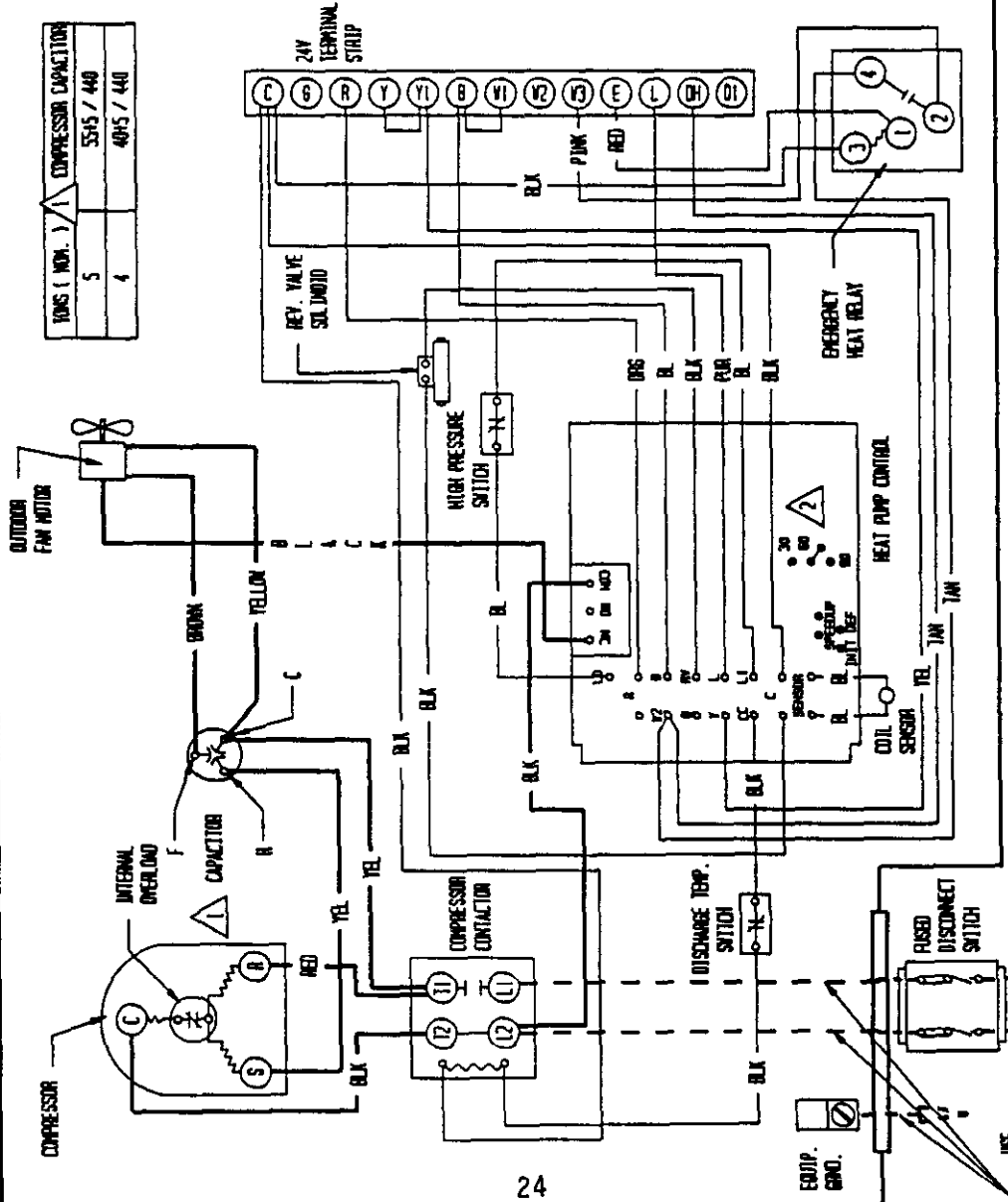

	FACTORY WIRING	FIELD WIRING
Low Voltage	---	---
High Voltage	---	---

USE COPPER CONDUCTORS ONLY

230/208-50-1

2 FACTORY SET ON 60 MIN. CYCLE  
 RECONNECT TO 30 FOR 30 MIN. CYCLE  
 RECONNECT TO 90 FOR 90 MIN. CYCLE

**LADDER DIAGRAM**

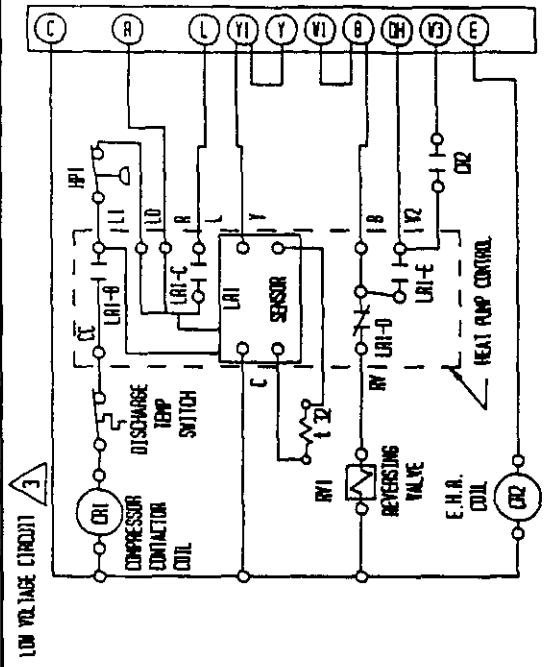
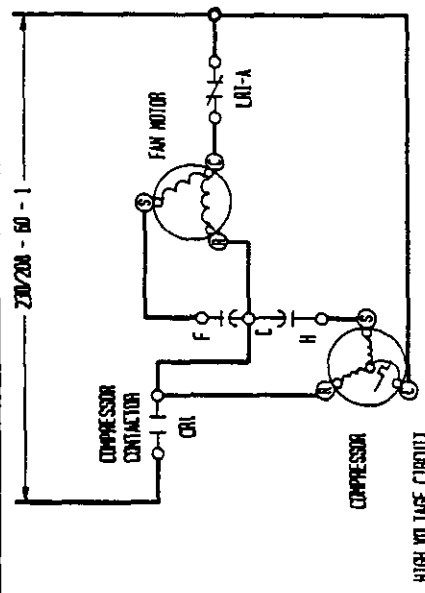

3 24 VOLTS FOR LOW VOLTAGE CONTROL CIRCUIT SUPPLIED BY INDOOR UNIT TRANSFORMER

**CONNECTION DIAGRAM**  
**DANGER: ELECTRICAL SHOCK HAZARD.**  
**DISCONNECT POWER BEFORE SERVICING**

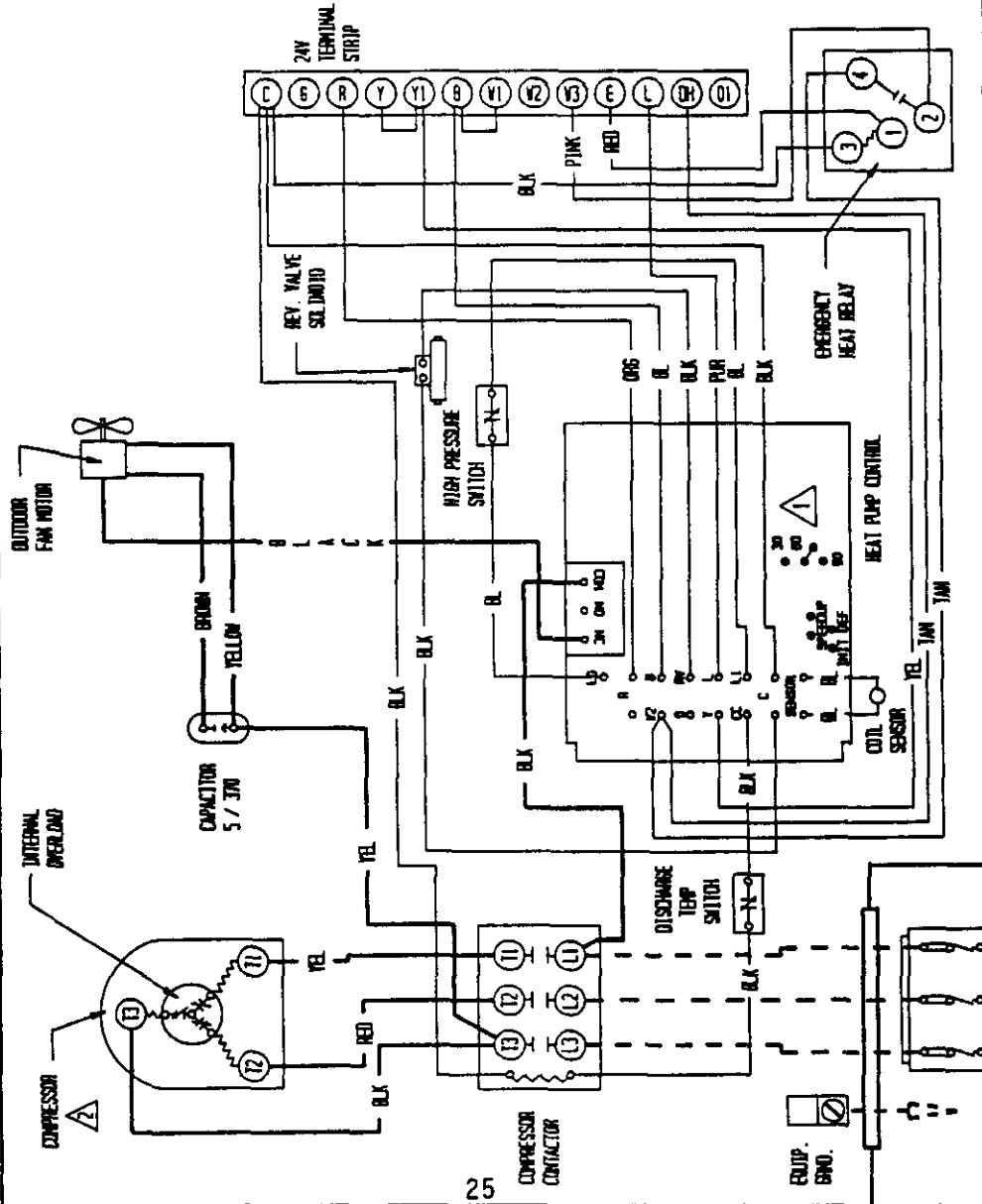

- 1. FACTORY SET ON 60 MIN. CYCLE  
 RECONNECT TO 30 FOR 30 MIN. CYCLE  
 RECONNECT TO 90 FOR 90 MIN. CYCLE
- 2. 3 PHASE SCROLL COMPRESSORS REQUIRE PROPER PHASING. REFER TO INSTALLATION INSTRUCTIONS FOR START UP INFORMATION

FACTORY WIRING	FIELD WIRING
---	---
---	---
---	---
---	---

Low Voltage  
 High Voltage

**LADDER DIAGRAM**

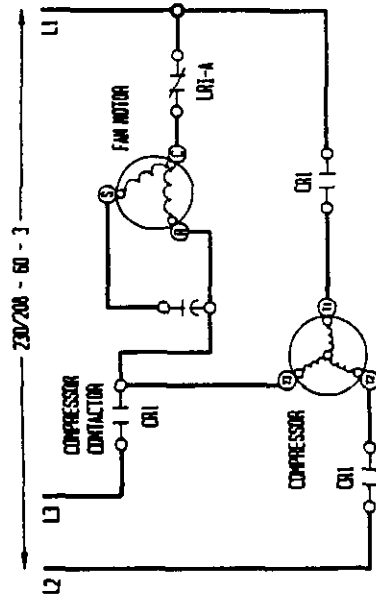

HIGH VOLTAGE CIRCUIT

LOW VOLTAGE CIRCUIT

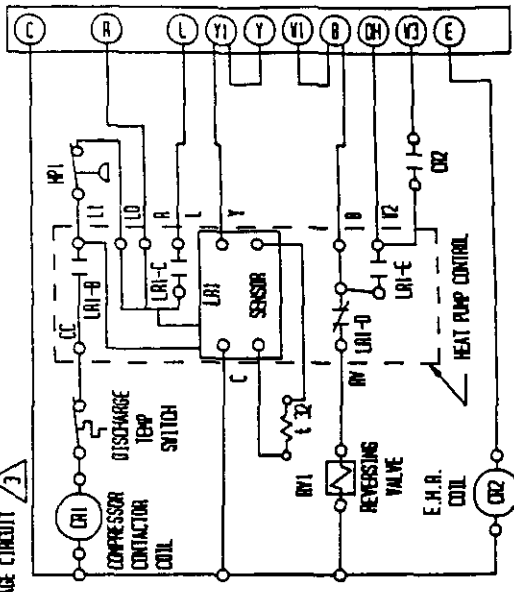

3. 24 VOLTS FOR LOW VOLTAGE CONTROL CIRCUIT SUPPLIED BY INDOOR UNIT TRANSFORMER

COOLING			Air Temperature Entering Outdoor Coil Degree F								
Indoor Model	Return Air Temperature	Pressure	75	80	85	90	95	100	105	110	115
BC48B Rated CFM 1525	75 deg. DB	Low Side	71	72	74	75	76	77	78	78	79
	62 deg. WB	High Side	178	194	210	226	243	260	278	296	314
	80 deg. DB	Low Side	76	77	79	80	81	82	83	83	84
	67 deg. WB	High Side	183	199	216	233	250	268	285	304	322
	85 deg. DB	Low Side	82	83	85	86	87	88	89	89	90
	72 deg. WB	High Side	189	206	223	241	259	277	296	314	333
A61AQ-A Rated CFM 1525	75 deg. DB	Low Side	76	77	79	80	81	82	82	83	83
	62 deg. WB	High Side	190	204	219	235	252	270	288	307	327
	80 deg. DB	Low Side	82	83	85	86	87	88	88	89	89
	67 deg. WB	High Side	195	210	225	242	259	277	296	316	336
	85 deg. DB	Low Side	87	89	91	93	94	95	96	96	96
	72 deg. WB	High Side	203	218	234	250	268	287	306	327	348

TABLE 11

HEATING			Air Temperature Entering Outdoor Coil Degree F														
Model	Return Air Temperature	Pressure	0	5	10	15	17	20	25	30	35	40	45	47	50	55	60
BC48B Rated CFM 1525	70 D.B.	Low Side	11	16	20	24	26	29	33	37	42	47	51	53	56	60	65
		High Side	147	153	160	166	168	172	177	183	188	193	198	200	203	207	212
A61AQ-A Rated CFM 1525	70 D.B.	Low Side	21	22	24	27	28	30	33	37	42	47	53	55	59	65	72
		High Side	156	158	161	165	166	168	172	176	180	184	189	191	194	199	204

Low side pressure  $\pm$  2 PSIG (suction line 6 inches from compressor)

High side pressure  $\pm$  5 PSIG (location line @ outdoor unit quick connect)

Tables are based upon rated CFM (airflow) across the evaporator coil and should be found under section titled "Refrigerant Charge" elsewhere in manual. If there is any doubt as to correct operating charge being in the system, the charge should be removed, system evacuated, and recharged to serial plate instructions.

48UBPQA  
48UBPQA-B

TABLE 12

COOLING			Air Temperature Entering Outdoor Coil Degree F									
Indoor Model	Return Air Temperature	Pressure	°									
			75	80	85	90	95	100	105	110	115	
BC48B Rated CFM 1700	75 deg. DB	Low Side	65	67	69	71	72	73	74	75	76	
	62 deg. WB	High Side	194	210	227	244	262	280	298	317	336	
	80 deg. DB	Low Side	70	72	74	76	77	78	79	80	81	
	67 deg. WB	High Side	199	216	233	251	269	287	306	325	345	
	85 deg. DB	Low Side	75	77	79	81	83	84	86	86	87	
	72 deg. WB	High Side	207	224	242	260	278	297	316	336	357	
A61AQ-A Rated CFM 1650	75 deg. DB	Low Side	71	73	75	77	78	79	80	80	80	
	62 deg. WB	High Side	199	218	236	254	272	290	307	324	341	
	80 deg. DB	Low Side	76	78	80	82	83	84	85	86	86	
	67 deg. WB	High Side	205	223	242	261	279	297	315	333	350	
	85 deg. DB	Low Side	82	84	86	88	89	90	91	92	92	
	72 deg. WB	High Side	211	231	251	270	289	308	326	344	362	

TABLE 13

HEATING			Air Temperature Entering Outdoor Coil Degree F														
Model	Return Air Temperature	Pressure	°														
			0	5	10	15	17	20	25	30	35	40	45	47	50	55	60
BC48B Rated CFM 1700	° 70 D.B.	Low Side	8	13	18	23	25	28	33	37	42	47	51	53	56	60	65
		High Side	149	157	165	173	176	181	188	195	202	209	215	218	222	228	234
A61AQ-A Rated CFM 1650	° 70 D.B.	Low Side	16	18	22	24	25	26	29	32	37	43	49	52	57	65	75
		High Side	169	169	171	173	174	176	180	185	191	198	206	206	214	224	235

Low side pressure  $\pm$  2 PSIG (suction line 6 inches from compressor)

High side pressure  $\pm$  5 PSIG (location line @ outdoor unit quick connect)

Tables are based upon rated CFM (airflow) across the evaporator coil and should be found under section titled "Refrigerant Charge" elsewhere in manual. If there is any doubt as to correct operating charge being in the system, the charge should be removed, system evacuated, and recharged to serial plate instructions.

TABLE 14

COOLING			Air Temperature Entering Outdoor Coil Degree								
Indoor Model	Return Air Temperature	Pressure	°								
			75	80	85	90	95	100	105	110	115
BC60B Rated CFM 1800	75 deg. DB	Low Side	65	66	68	70	71	72	74	75	76
	62 deg. WB	High Side	191	208	225	243	260	277	295	312	330
	80 deg. DB	Low Side	70	71	73	75	76	77	79	80	81
	67 deg. WB	High Side	196	214	232	249	267	285	303	321	339
	85 deg. DB	Low Side	74	76	78	80	82	84	85	86	87
	72 deg. WB	High Side	204	222	240	258	276	294	313	332	351
	75 deg. DB	Low Side	64	66	68	70	71	72	73	74	75
	62 deg. WB	High Side	190	206	223	240	257	275	293	311	330
A61AQ-A Rated CFM 1800	80 deg. DB	Low Side	69	71	73	75	76	77	78	79	80
	67 deg. WB	High Side	196	212	229	246	264	282	301	320	339
	85 deg. DB	Low Side	74	76	78	80	82	83	85	85	86
	72 deg. WB	High Side	202	219	237	255	273	292	311	331	351

TABLE 15

HEATING			Air Temperature Entering Outdoor Coil Degree F														
Model	Return Air Temperature	Pressure	°														
			0	5	10	15	17	20	25	30	35	40	45	47	50	55	60
BC60B Rated CFM 1800	° 70 D.B.	Low Side	15	18	21	25	26	28	32	36	41	46	51	53	56	62	68
		High Side	156	160	164	168	170	173	179	185	192	199	208	211	216	226	235
A61AQ-A Rated CFM 1800	° 70 D.B.	Low Side	19	20	22	25	26	28	31	35	40	45	51	53	57	63	70
		High Side	169	175	181	187	190	194	201	208	215	222	230	233	238	246	254

Low side pressure  $\pm$  2 PSIG (suction line 6 inches from compressor)  
High side pressure  $\pm$  5 PSIG (location line @ outdoor unit quick connect)

Tables are based upon rated CFM (airflow) across the evaporator coil and should be found under section titled "Refrigerant Charge" elsewhere in manual. If there is any doubt as to correct operating charge being in the system, the charge should be removed, system evacuated, and recharged to serial plate instructions.