

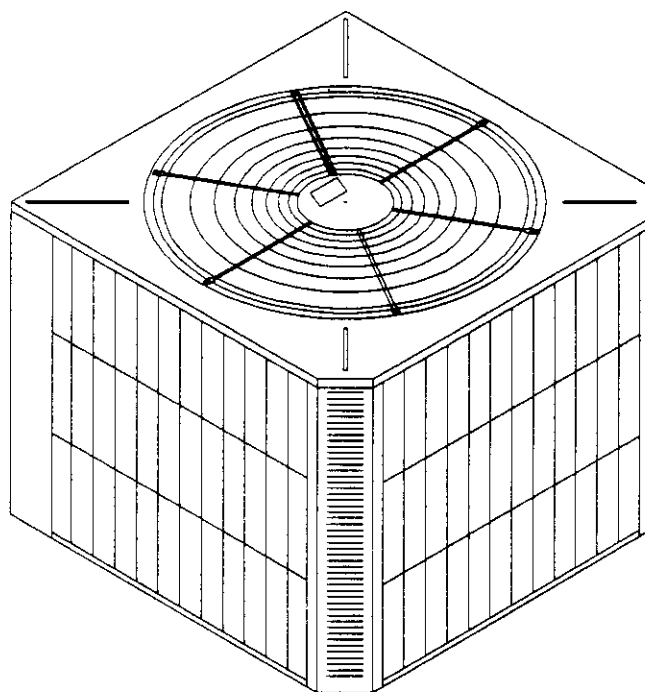

INSTALLATION INSTRUCTIONS SPLIT HEAT PUMP OUTDOOR SECTION

**MODELS: 24UHPQC, 30UHPQC, 36UHPQC,
42UHPQA, 48UHPQB, 48UHPQB-B,
60UHPQB, 60UHPQB-B**



**FOR USE WITH:
MATCHING INDOOR BLOWER COIL UNITS
AND MATCHING ADD ON COIL UNITS ONLY**

BARD MANUFACTURING COMPANY
Bryan, Ohio 43506

Since 1914...Moving, ahead just as planned.

Manual:	2100-178 Rev. K
Supersedes:	Rev. J
File:	Volume I, Tab 5
Date:	May, 1995

CONTENTS

APPLICATION AND LOCATION . 2	CHARGING INSTRUCTIONS ... 12
GENERAL 2	PRESSURE SERVICE PORTS 12
SHIPPING DAMAGE 2	THREE PHASE SCROLL COMPRESSOR START UP INFORMATION 12
APPLICATION 2	SYSTEM START UP 12
LOCATION 2	TOTAL SYSTEM CHARGE FOR SPLIT SYSTEMS 13
SETTING THE UNIT 2	SERVICE 14
SLAB MOUNTING 2	SERVICE HINTS 14
ROOF MOUNTING 2	FAN BLADE SETTING DIMENSIONS 14
WINTER INSTALLATION BELOW 32°F 4	DISCHARGE TEMPERATURE 14
INSTALLING REFRIGERANT TUBING 4	CRANKCASE HEATERS 14
PRECHARGED TUBING CONNECTIONS: QUICK CONNECT INDOOR UNIT AND QUICK CONNECT OUTDOOR UNIT® 4	COMPRESSOR SHORT CYCLE PROTECTION 15
FIELD FABRICATED TUBING CONNECTIONS: SWEAT INDOOR UNIT AND QUICK CONNECT OUTDOOR UNIT USING CTO KIT 5	DEFROST CYCLE 15
WIRING INSTRUCTIONS 8	SOLID STATE HEAT PUMP CONTROL TROUBLESHOOTING PROCEDURE 15
GENERAL 8	AIR FLOW CAPACITIES 17
CONTROL CIRCUIT WIRING 8	WIRE DIAGRAMS 20
WALL THERMOSTATS 8	AIR SOURCE HEAT PUMP PERFORMANCE REPORT 22
THERMOSTAT INDICATOR LAMPS 9	
EMERGENCY HEAT POSITION 9	
OUTDOOR THERMOSTAT 9	
SEQUENCE OF OPERATION WHEN USED WITH INDOOR BLOWER COIL 9	
GENERAL OPERATION—HEAT PUMP/FOSSIL FUEL FURNACE 9	
NOTE ON BLOWER OPERATION 10	

FIGURE 1 — NOMENCLATURE EXPLANATION — Example:

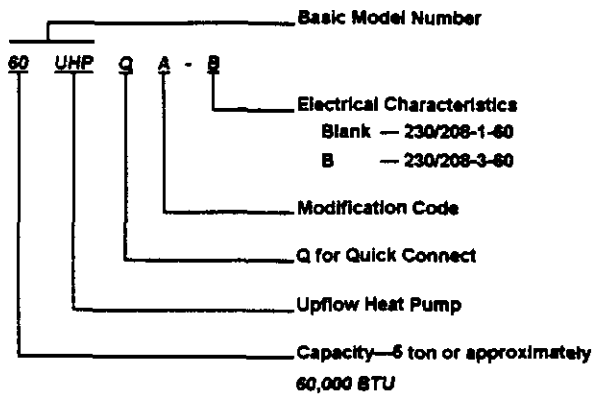

TABLE 1 — DIMENSIONS

Basic Model No.	"W" Width	"D" Depth	"H" Height
24UHPQC			
30UHPQC			
36UHPQC	32-1/2"	32-1/2"	26"
42UHPQA			
48UHPQB			
60UHPQB	32-1/2"	32-1/2"	36"

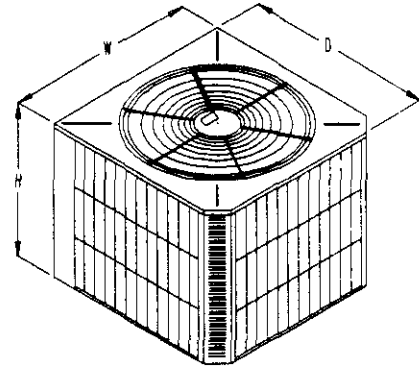

TABLE 2 — RATED CFM AND AIRFLOW DATA (WET COIL — COOLING)

Condensing Unit Model Number	Evaporator Coil Model Number	Rated Airflow		Rated ESP ②	Motor Speed Tap	Recommended Air Flow Range	System Orifice Required
		CFM	Pressure Drop H ₂ O ①				
24UHPQC	BC24B	800		.15	High	700 - 910	.063 ◀
	A36AQ-A	800	.15				
30UHPQC	BC36B	1050		.25	Low	900 - 1150	.069 ◀
	A36AQ-A	1050	.25				
	A37AQ-A	1050	.20				
36UHPQC	BC36B	1200		.15	High	1020 - 1320	.072
	A37AQ-A	1200	.25				
42UHPQA	BC48B	1525		.35	Low	1300 - 1750	.078
	A61AQ-A	1525	.20				
48UHPQB	BC48B	1700		.25	High	1450 - 1950	.078
	A61AQ-A	1650	.25				
60UHPQB	BC60B	1800		.20	High	1530 - 2050	.092
	A61AQ-A	1800	.30				

① Measured across the evaporator coil assembly, including drain pan.

② External static pressure available for the duct system—supply and return. All blower coils have multi-speed motors, and value shown is at the recommended rated speed. Consult specification airflow charts with the blower coil units for complete information at other speeds.

◀ IMPORTANT — Proper sized orifice is not factory installed in indoor section. Proper orifice size is shipped with outdoor unit packaged with its installation instructions for indoor sections listed on this page. The orifice must be replaced with the proper orifice shown above.

TABLE 3 — ELECTRICAL DATA

MODELS	24UHPQC	30UHPQC	36UHPQC	42UHPQA	48UHPQB	48UHPQB-B	60UHPQB	60UHPQB-B
Electrical Rating (60Hz/V/Ph)	230/208-1	230/208-1	230/208-1	230/208-1	230/208-1	230/208-3	230/208-1	230/208-3
Operating Voltage Range	197-253	197-253	197-253	197-253	197-253	197-253	197-253	197-253
Minimum Circuit Ampacity	18	19.5	24.5	26.4	36	21.4	41	27.2
① Field Wire Size	#12	#12	#10	#10	#8	#12	#8	#10
② Delay Fuse Max. or Ckt. Bkr.	30	30	40	45	60	35	60	45
Total Unit Amps 230/208	12.1/14.1	12.9/15.6	18.5/19.8	19.3/19.0	25.8/28.5	15.7/17.4	28.9/33.2	18.3/22.2
COMPRESSOR								
Rated Load Amps 230/208	11.0/13.0	11.8/14.5	15.4/18.7	17.8/17.5	24.3/27.0	14.2/15.9	26.6/30.9	16.0/19.9
Branch Circuit Selection Current	13.0	14.5	18.7	19.9	27.0	15.9	30.9	19.9
Lock Rotor Amps 230/208	56/56	72.5/72.5	88/88	107/107	129/129	99/99	169/169	123/123
FAN MOTOR & COMPRESSOR								
Fan Motor — HP/RPM		1/6 - 825			1/4 - 825			1/3 - 1075
Fan Motor — Amps		1.1			1.5			2.3
Fan — DIA/CFM		24" - 3000			24" - 3100			24" - 3400

① 75° C copper wire size.

② Maximum time delay fuse or HACR type circuit breaker.

APPLICATION AND LOCATION

GENERAL

These instructions explain the recommended method to install the air cooled remote type outdoor unit, the interconnecting refrigerant tubing and the electrical wiring connections to the unit.

The outdoor units are to be used in conjunction with the matching indoor coils or indoor blower coil for comfort cooling/heating applications as shown in the specification sheet.

These instructions and any instructions packaged with any separate equipment required to make up the entire system should be carefully read before beginning the installation. Note particularly "Connecting Quick-Connect Couplings, Starting Procedure" and any tags and/or labels attached to the equipment.

While these instructions are intended as a general recommended guide, they do not supersede any national and/or local codes in any way. Authorities having jurisdiction should be consulted before the installation is made.

SHIPPING DAMAGE

Upon receipt of equipment, the carton should be checked for external signs of shipping damage. If damage is found, the receiving party must contact the last carrier immediately, preferably in writing, requesting inspection by the carrier's agent.

APPLICATION

Size of unit and duct system for a proposed installation should be based on heat loss and heat gain calculation made according to methods of Air Conditioning Contractors of America. The air duct should be installed in accordance with the Standards of the National Fire Protection Association for the Installation of Air Conditioning and Ventilating Systems of Other Than Residence Type, NFPA No. 90A and Residence Type Warm Air Heating and Air Conditioning Systems, NFPA No. 90B. Where local regulations are at a variance with instructions, installer should adhere to local codes.

For applications in Canada, the installation of the system must be made in accordance with CSA Standards C22.1, Canadian Electrical Code, Part I; C273.5 Installation Requirements for Air-To-Air Heat Pumps; and B52, Mechanical Refrigeration Code.

LOCATION

The outdoor unit is designed to be located outside with free and unobstructed outdoor coil air inlet and discharge. It must also permit access for service and installation. Outdoor air enters the coil on three sides and discharges upward from the top. Refrigerant and electrical connections are made from the rear of the unit as shown in FIGURE 3 with electrical service access on the right side. The unit can be installed with the rear of the unit "close to the wall", however, additional service clearance at the back of the unit would be desirable if practical for unit service. The compressor can be serviced through the top.

SETTING THE UNIT

GENERAL—The unit must be located outside, or in a well ventilated area. It must not be in the space being heated or cooled. A sound absorbing material should be considered if the unit is to be installed in such a position or location that might cause transmission of sound or vibration to the living area or adjacent buildings.

SLAB MOUNTING

In areas where winter temperatures DO NOT go below 32°F for periods over twelve hours, the unit may be slab mounted at grade level. When installing the unit at grade level, install on a concrete slab at least four inches above finished grade level. Slab should have a slope tolerance away from the building structure of at least 1/4 inch per foot, while being level from side to side. This will prevent ice buildup under the unit during defrost cycles. Place slab in a location where run-off water from higher ground will not collect around unit. See FIGURE 2.

A minimum clearance should be provided between the coil inlet and any building surfaces. Provide at least 4 feet between coil outlet and any structures. Provide a minimum of 8 inches clearance on the service access side of the unit. Refer to FIGURE 3.

ROOF MOUNTING

When a unit is installed in areas where low ambient temperatures or strong winter winds exist, it should be placed so prevailing winter winds are not in direct line with the heat pump coil. If this is not possible, a wind barrier should be constructed. Place barrier 24 inches from the coil side of the unit and in the direction of the prevailing winds. Size barrier at least the same height and 6 to 12 inches wider than unit. See FIGURE 4.

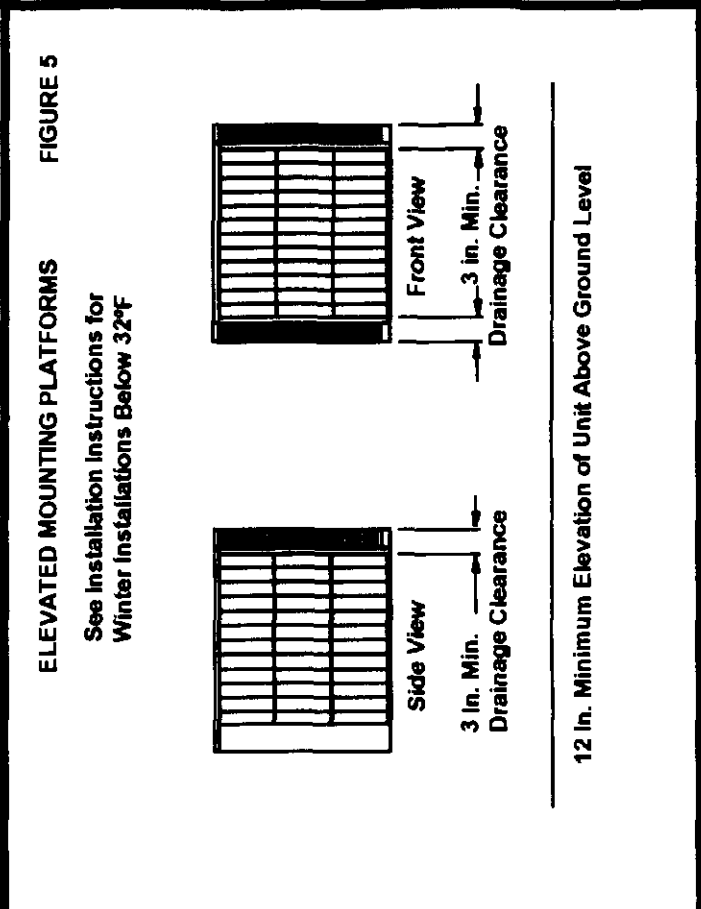
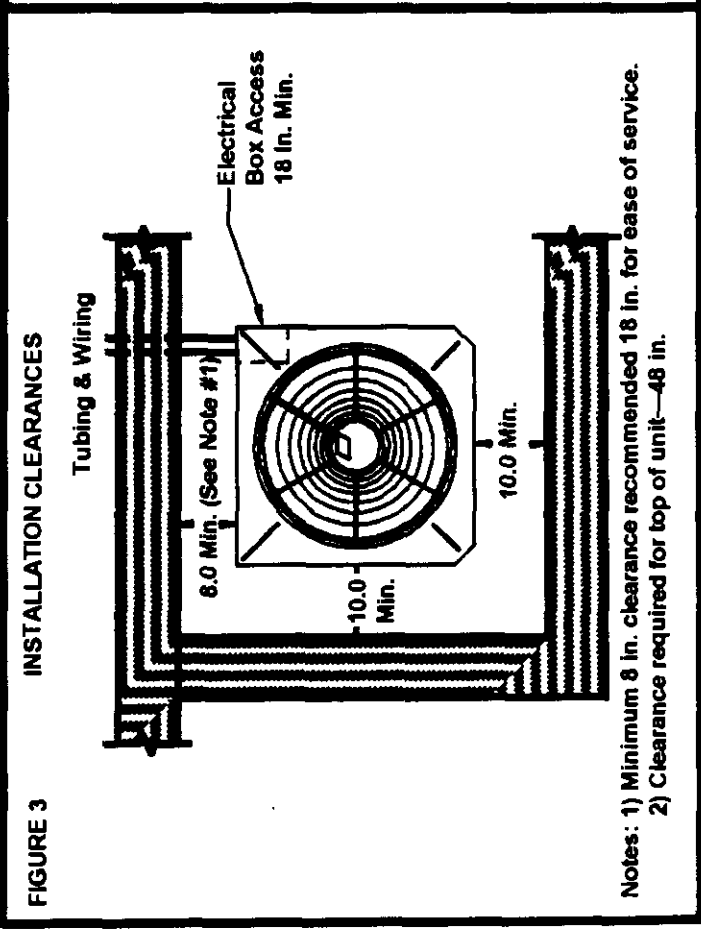
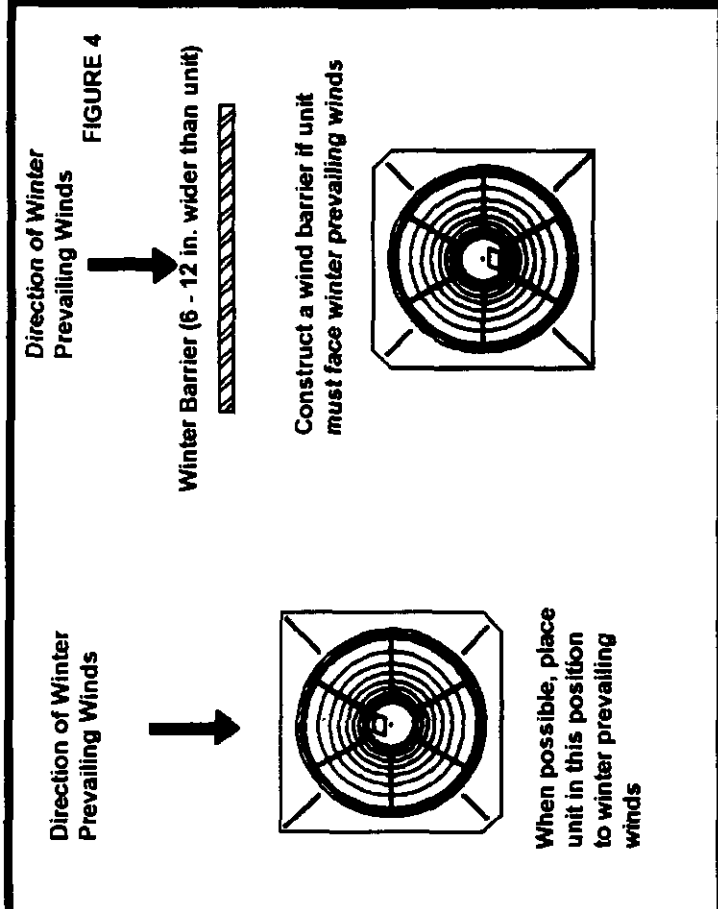
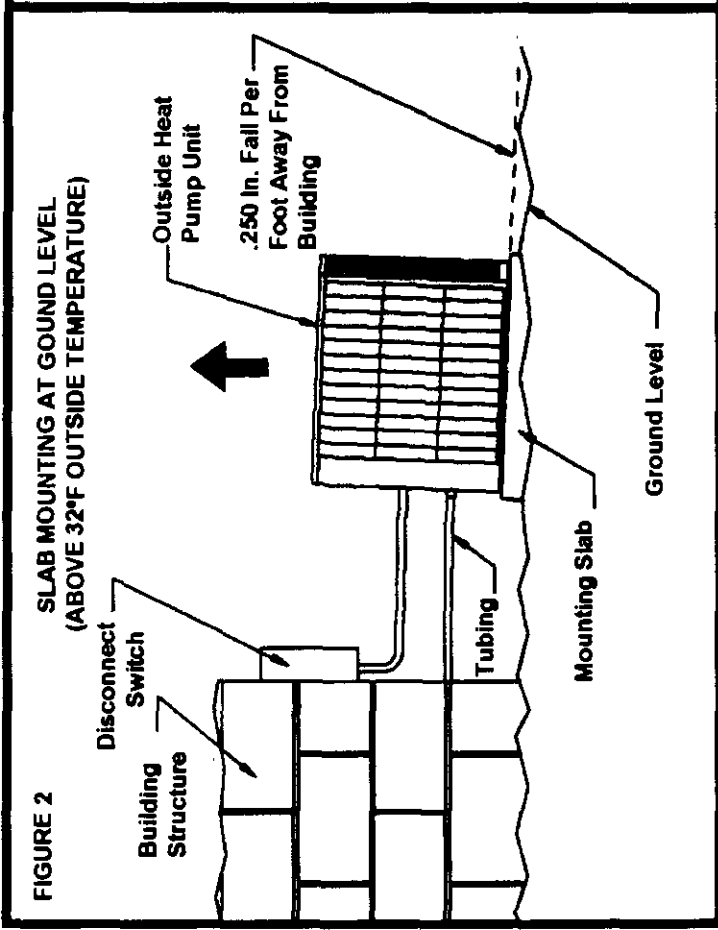

WINTER INSTALLATION BELOW 32°F

In areas where winter conditions go below 32°F for extended periods, the unit must be elevated above the mounting surface to prevent snowfall or defrost ice accumulation from interfering with the operation of the unit. A minimum of twelve inch elevation is recommended, while greater elevation may be required for areas of high snow accumulation. For ease of installation, a heat pump stand is available from Bard. Poured concrete, steel framework, brick, cement block, etc. can be utilized to construct a suitable raised mounting platform. See FIGURE 5. The mounting platform must provide support on all 5 dimples located on the unit base and must not rest against the unit base.

INSTALLING REFRIGERANT TUBING

The information that follows on installing refrigerant tubing and for changing the system orifice (if required) covers applications listed in the front of this installation instruction only. Although other indoor units may be of similar construction, the installation instructions for these units should be consulted for proper installation of those units prior to installation.

This information is provided for the field service personnel to install refrigerant tubing in compliance with Section 608 of Title VI National Recycling and Emission Reduction Program for the U.S. Clean Air Act effective July 1, 1992.

Consult manual 2100-002 on procedure for leak test—evacuation—charging before installation refrigerant tubing that requires any refrigerant recovery or system evacuation. Manual 2100-002 is included with the unit installation instruction package when shipped from the factory.

FIGURE 6

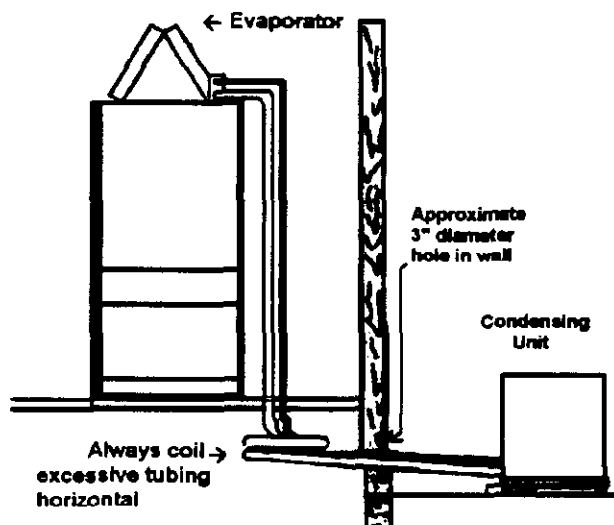

PRECHARGED TUBING CONNECTIONS: QUICK CONNECT INDOOR UNIT AND QUICK CONNECT OUTDOOR UNIT ①

Examine carefully the two lengths of precharged tubing furnished with the system. The larger is the suction line and the smaller is the liquid line. The end of the tubing with the hex nut and gauge port is to be attached to the outdoor unit.

STEP 1—Unroll the tubing, being careful not to kink and route both the suction line and liquid line between the indoor unit and outdoor unit.

Before fastening either end, use a tubing bender to make any necessary bends in tubing. When necessary to bend the insulated tube suction line, cut the insulation around its circumference at a distance far enough beyond the point of the bend so as to clear the tubing bender. Slip the insulation back together and vapor seal the joint with tape. Coil any excess tubing in a horizontal place with the slope of the tubing toward the condensing unit.

CAUTION: 1. Be careful not to tear the insulation when pushing it through hole in masonry or frame walls. 2. When sealing the tube opening in house wall, use a soft material to prevent tube damage and vibration transmission. 3. Avoid excessive bending in any one place to avoid kinking.

NOTE: DO NOT CONNECT LINE SETS! If orifice needs to be changed, change out orifice first.

If the orifice does not have to be changed, skip the instructions outlined further in Step 2 and proceed to Step 9.

STEP 2—To recover charge from the indoor unit.

- A. Connect the suction line only to the indoor unit as outlined in Steps 9, 10, and 11.
- B. Recover indoor unit and suction line unit charge through service port located on suction line.

STEP 3—Disassemble Flow Control Assembly by turning body hex.

STEP 4—If existing orifice has not dropped out of the body when disassembled, remove by using a pin or paper clip. Discard this original orifice.

STEP 5—Insert proper sized orifice fully into the flow control body with rounded "bullet" nose towards the unit as shown. Insure the orifice stays inserted in body before connecting

mating half. See chart in the outdoor unit installation instructions for proper size.

CAUTION: Be sure there is no dirt introduced into the flow control—orifice assembly. Be sure and install the orifice with the bullet nose pointing in the proper direction as shown in FIGURE 7. Failure to do so will result in improper operation.

FIGURE 7—FLOW CONTROL ASSEMBLY FIELD ORIFICE REPLACEMENT INSTRUCTIONS

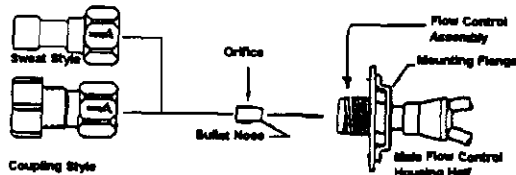

STEP 6—Thread assembly halves together by hand to insure proper mating of threads and tighten until bodies “bottom” or a definite resistance is felt.

STEP 7—Using a marker pen or ink pen, mark a line lengthwise from the union nut to the bulkhead. Then tighten an additional 1/6 turn (or 1 hex flat). The misalignment of the line will show the amount the assembly has been tightened. This final 1/6 turn is necessary to insure the formation of the leakproof joint.

STEP 8—Evacuate the suction line and indoor unit through service port located on suction line before connecting all other tubing. Refer to section later in installation instructions for details on setting the proper refrigerant charge.

STEP 9—Remove (remaining) protector caps and plugs (if orifice was changed), inspect fittings and if necessary carefully wipe coupling seats and threaded surfaces with a clean cloth to prevent the inclusion of dirt or any foreign material in the system.

STEP 10—Lubricate male half diaphragm and synthetic rubber seal with refrigerant oil. Starting with the indoor coil, thread coupling halves together by hand to insure proper mating of threads. Be sure to hold the coupling firmly to prevent movement of the coupling and tubing. Failure to do so could tear out the diaphragm causing a blockage of the system. Use proper size wrenches (on coupling body hex and on union nut) and tighten until coupling bodies “bottom” or a definite resistance is felt.

CAUTION: After starting to tighten up the fitting, never try to back it off or take it apart.

STEP 11—Using a marker or ink pen, mark a line lengthwise from the coupling union nut to the bulkhead. Then tighten an additional 1/4 turn—the misalignment of the line will show the amount the coupling has been tightened. This final 1/4 turn is necessary to insure the formation of leak proof joint. If a torque wrench is used, the following torque values are recommended:

TABLE 4

Coupling Size	Ft. Lb.
-6	10 - 12
-10	35 - 45
-11	35 - 45
-12	50 - 65

Repeat Steps 10 and 11 on outdoor section making sure to locate the gauge port in a 45° angle from a vertical up position so as to be accessible for gauge connections.

STEP 12—Leak test all connections using an electronic leak detector or a halide torch.

STEP 13—When tubing is installed in attics or drop ceilings, insulate the couplings on the larger tube thoroughly with 3/8" wall thickness, closed cell sponge tube insulation or equivalent. Failure to insulate will result in water damage to ceiling since the fitting will “sweat” and drop water on the ceiling.

Ⓞ **NOTE:** The maximum distance for precharge tubing between the outdoor and indoor unit is 45 feet.

FIELD FABRICATED TUBING CONNECTIONS: SWEAT INDOOR UNIT AND QUICK CONNECT OUTDOOR UNIT USING CTO KIT

Use only refrigeration grade (dehydrated and sealed) copper tubing. Care must be taken to insure that the tubing is kept clean and dry before and during installation. Do not remove the plugs from the tubing ends, coil connections or base valves until the connection is ready to be brazed.

The suction line must be insulated with a minimum of 3/8" Armaflex or equivalent before cutting and making connections.

STEP 1—Being careful not to kink, route both the suction line and liquid line between the indoor unit and outdoor unit. Use a tubing bender to make any necessary bends in tubing. When

necessary to bend the insulated tube suction line, cut the insulation around its circumference at a distance far enough beyond the point of the bend so as to clear the tubing bender. Slip the insulation back together and vapor seal the joint with tape. Coil any excess tubing in a horizontal place with the slope of the tubing toward the condensing unit.

CAUTION: 1. Be careful not to tear the insulation when pushing it through hole in masonry or frame walls. 2. When sealing the tube opening in house wall, use a soft material to prevent tube damage and vibration transmission. 3. Avoid excessive bending in any one place to avoid kinking.

STEP 2—The tubing ends should be cut square. Make sure it is round and free of burrs at the connecting ends. Clean the tubing to prevent contaminants from entering the system.

NOTE: Do not braze lines to indoor unit or make any tubing connections at outdoor unit at this time.

If the orifice does not have to be changed, skip the instructions outlined further in Step 3 and proceed to Step 8.

STEP 3—Disassemble Flow Control Assembly by turning body hex.

STEP 4—If existing orifice has not dropped out of the body when disassembled, remove by using a pin or paper clip. Discard this original orifice.

STEP 5—Insert proper sized orifice fully into the flow control body with rounded “bullet” nose towards the unit as shown. Insure the orifice stays inserted in body before connecting mating half. See chart in the outdoor unit installation instructions for proper size.

CAUTION: Be sure there is no dirt introduced into the flow control—orifice assembly. Be sure and install the orifice with the bullet nose pointing in the proper direction as shown in FIGURE 7. Failure to do so will result in improper operation.

STEP 6—Thread assembly halves together by hand to insure proper mating of threads and tighten until bodies “bottom” or definite resistance is felt.

STEP 7—Using a marker pen or ink pen, mark a line lengthwise from the union nut to the bulk-head. Then tighten an additional 1/6 turn (or 1 hex flat). The misalignment of the line will show the amount the assembly has been

tightened. This final 1/6 turn is necessary to insure the formation of the leakproof joint.

STEP 8—DO NOT make any tubing connection at outdoor unit at this time. Make all brazing of joints and evacuate both suction line, liquid line, and indoor coil first.

Wrap a wet rag around the copper stub before brazing.

STEP 9—Flux the copper tube and insert into the stub. Braze the joint using an alloy of silver or copper and phosphorus with a melting temperature above 1100°F for copper to copper joints. The phosphorus will act as a flux, therefore, no flux will be required.

A copper-silver alloy with a high silver content should be used when iron or steel material is involved in the joint. These alloys require the use of silver solder flux. Alloys containing phosphorus should not be used with iron or steel. Phosphorus reacts with iron, forming iron phosphate which is extremely brittle.

CAUTION: 1. Brazing alloys with a melting temperature below 700°F should not be used. 2. Lead-tin or tin-antimony solders should not be used due to their low melting point and necessity for corrosive fluxes.

To further prevent the formation of copper oxide inside the tubing, dry nitrogen may be purged through the refrigerant system during brazing.

WARNING: Never purge or pressurize a system with oxygen. An explosion and fire will result.

STEP 10—After brazing, quench with wet rag to cool the joint and remove any flux residue.

STEP 11—Leak test all connections using an electronic leak detector or a halide torch.

STEP 12—Evacuate the suction line, liquid line, and indoor unit through service ports located on suction and liquid line before connecting to outdoor unit. Refer to section later in installation instructions for details on setting the proper refrigerant charge.

STEP 13—Remove (remaining) protector caps and plugs (on outdoor unit). Inspect fittings and if necessary carefully wipe coupling seats and threaded surfaces with a clean cloth to prevent the inclusion of dirt or any foreign material in the system.

STEP 14—Lubricate male half diaphragm and synthetic rubber seal with refrigerant oil. Start with the indoor coil, thread coupling halves together by hand to insure proper mating of threads. Be sure to hold the coupling firmly to prevent movement of the coupling and tubing. Failure to do so could tear out the diaphragm causing a blockage of the system. Use proper size wrenches (on coupling body hex and on union nut) and tighten until coupling bodies “bottom” or a definite resistance is felt.

CAUTION: After starting to tighten up the fitting, never try to back it off or take it apart.

STEP 15—Using a marker or ink pen, mark a line lengthwise from the coupling union nut to the bulkhead. Then tighten an additional 1/4 turn—the misalignment of the line will show the amount the coupling has been tightened. This final 1/4 turn is necessary to insure the formation of leak proof joint. If a torque wrench is used, the following torque values are recommended.

Coupling Size	Ft. Lb.
-6	10 - 12
-10	35 - 45
-11	35 - 45
-12	50 - 65

STEP 16—Leak test all connections using an electronic leak detector or a halide torch.

STEP 17—When tubing is installed in attics or drop ceilings, insulate the couplings on the larger tube thoroughly with 3/8" wall thickness, closed cell sponge tube insulation or equivalent. Failure to insulate will result in water damage to ceiling since the fitting will “sweat” and drop water on the ceiling.

WIRING INSTRUCTIONS

GENERAL

All wiring must be installed in accordance with the National Electrical Code and local codes. In Canada, all wiring must be installed in accordance with the Canadian Electrical Code and in accordance with the regulations of the authorities having jurisdiction. Power supply voltage must conform to the voltage shown on the unit serial plate. A wiring diagram of the unit is attached to the inside of the electrical cover. The power supply shall be sized and fused according to the specifications supplied. A ground lug is supplied in the control compartment for equipment ground.

The control circuit is a 24 volt circuit. "Typical" wiring diagrams illustrating some of the various circuits which could be encountered can be found in the installation instructions of the indoor section.

The unit rating plate lists a "Maximum Time Delay Fuse" or "HACR Type" circuit breaker that is to be used with the equipment. The correct size must be used for proper circuit protection and also to assure that there will be no nuisance tripping due to the momentary high starting current of the compressor motor.

CONTROL CIRCUIT WIRING

For split systems, the minimum control circuit wiring gauge needed to insure proper operation of all controls in both indoor and outdoor units will depend on two factors.

1. The rated VA of the control circuit transformer.
2. The maximum total distance of the control circuit wiring. (This is the distance between the wall thermostat to the indoor unit plus the distance between the indoor unit to the outdoor unit.)

The following table should be used to determine proper gauge of control circuit wiring required.

TABLE 6

Rated VA of Control Circuit Transformer	Transformer Secondary FLA @ 240V	Maximum Total Distance of Control Circuit Wiring in Feet
40	1.8	20 gauge - 65
		18 gauge - 90
		16 gauge - 145
		14 gauge - 230
50	2.1	20 gauge - 45
		18 gauge - 60
		16 gauge - 100
		14 gauge - 160
65	2.7	12 gauge - 250
		20 gauge - 40
		18 gauge - 55
		16 gauge - 85
		14 gauge - 135
		12 gauge - 210

- Example: 1. Control circuit transformer rated at 40VA.
 2. Maximum total distance of control circuit wiring 85 feet.

From TABLE 6, minimum of 18 gauge wire should be used in the control circuit wiring.

For control circuit transformers rated other than those listed, use the next lower rated transformer listed.

- Example: 1. Control circuit transformer rated at 55VA.
 From table, use 50VA transformer.

There are two (2) separate control diagrams for fossil fuel furnaces with heat pump. Control diagrams for matching blower coils can be found in the blower coil installation instructions.

TABLE 7

Heat Pump System	Gas Furnace Control Diagram	Oil Furnace Control Diagram
All Models	4091-200	4091-201

WALL THERMOSTATS

The following wall thermostats and subbases should be used as indicated, depending on the application.

TABLE 8 — THERMOSTATS AND SUBBASES

Part No.	Model No.	Description
8403-017	T874R1129	Thermostat— 1 st. cool, 2 stg. heat, 1st stage fixed 2nd stg. adj., heat anticipators
8404-009	Q674L1181	Subbase — System switch: EM.HT.-Heat-Off-Cool Fan switch: On-Auto Special Feature — Manual changeover (non-cycling rev. valve) EM.HT. light and system check light
8403-018	T874N1024	Thermostat— 1 stg. cool, 2 stg. heat, 1st stage fixed 2nd stg. adj., heat anticipators
8404-010	Q674F1261	Subbase — System switch: Off-Cool-Auto-Heat-EM.HT. Fan switch: On-Auto Special Feature — Auto system changeover, EM.HT. light and system check light
8403-024	IF58-45	Thermostat— 1 stg. cool, 2 stg. heat, 1st stage fixed, 2 stg. adj. heater System switch: EM.HT.-Heat-Off-Cool Fan switch: On-auto
8403-034	IF94-80	Thermostat— 2 stg. cool, 2 stg. heat, electronic Subbase — Manual or automatic changeover, 2 set-up/ set-back periods per day, 5 or 7 day programming

IMPORTANT NOTE: All thermostat and subbase combinations except IF94-80 shown above incorporate the following features: Man-Auto fan switch, Off-Heat-Cool-Em. Heat Switch, and two (2) indicator lamps— one for emergency heat and one for compressor malfunction.

THERMOSTAT INDICATOR LAMPS

The red lamp marked "EM.HT." comes on and stays on whenever the system switch is placed in the emergency heat position. The green lamp marked "check" will come on if the high pressure switch opens and that prevents the compressor from running. To reset high pressure switch, place thermostat in off position then back to on position.

EMERGENCY HEAT POSITION

The operator of the equipment must manually place the system switch in this position. This is done when there is a known problem with the outdoor section, or when the green "check" lamp comes on indicating a problem.

OUTDOOR THERMOSTAT

Heat pump compressor operation at outdoor temperatures below -5°F are neither desirable nor advantageous in terms of efficiency. Since most equipment at time of manufacture is not designated for any specific destination of the country and most of the equipment is installed in areas not approaching this low outdoor temperature range, an outdoor thermostat (used as a compressor cut-off) is a field installed option.

Outdoor thermostats are available to hold off various stages of electric heat or fossil fuel furnace, until needed as determined by outdoor temperature. The set point of the thermostat(s) is variable with geographic region and sizing of the heating equipment to the structure. Utilization of the Heating Application Data and the heat loss calculation of the building is required in determining the correct set points.

SEQUENCE OF OPERATION WHEN USED WITH INDOOR BLOWER COIL

COOLING—Circuit R-Y makes at thermostat pulling in compressor contactor starting the compressor and outdoor motor. The G (indoor motor) circuit is automatically completed on any call for cooling operation, or can be energized by manual fan switch on subbase for constant air circulation.

HEATING—A 24V solenoid coil on reversing valve controls heating cycle operation. Two thermostat options, one allowing "Auto" changeover from cycle to cycle and the other constantly energizing solenoid coil during heating season and thus eliminating pressure equalization noise except during defrost, are to be used. On "Auto" option, a circuit is completed from R-W1 and R-Y on each heating "on" cycle, energizing reversing valve solenoid and pulling in compressor contactor starting compressor and outdoor motor. R-G also make starting indoor blower motor. Heat pump heating cycle is now in operation. The second option has no "Auto"

changeover position, but instead energizes the reversing valve solenoid constantly whenever the system switch on subbase is placed in "heat" position, the "B" terminal being constantly energized from R. A thermostat demand for heat completes R-Y circuit, pulling in compressor contactor starting compressor and outdoor motor. R-G also make starting indoor blower motor.

GENERAL OPERATION—HEAT PUMP/ FOSSIL FUEL FURNACE

This type of system is a one-stage heating system, even though a two-stage heat wall thermostat is used. The thermostats specified for use are special thermostats for heat pumps with extra switches, signal lights, and special circuitry for heat pumps, and by design are two-stage heating thermostats. Since the extra features are also required for the special heat pump/fossil fuel systems, the same thermostats are used, but the second stage circuit is not used. This is further explained in the next paragraph.

While it would be possible to electrically connect the furnace to the second stage of the thermostat, the heat pump coil is located downstream from the furnace heat exchanger, and continuous simultaneous operation of the furnace and heat pump will result in excessive high discharge pressures and temperatures at the compressor and resultant overload tripping problems. For this reason, the control circuit wiring diagrams shown later in this manual will not allow the furnace to operate except during defrost cycles unless an outdoor thermostat is added to the circuit. The addition of an outdoor thermostat used as a changeover thermostat will switch the system from heat pump heating to furnace heating based on the outdoor temperature. At no time will continuous operation of the heat pump and furnace be allowed.

An outdoor thermostat is used as a changeover thermostat, properly set to control at or just above the balance point, will allow the most economical operation of the system. The changeover (outdoor) thermostat switches off the heat pump on the fossil fueled furnace, based on the outdoor temperature. There is a 5°F differential in the changeover (outdoor) thermostat, so when the heat pump is de-energized and the furnace is activated, the outdoor temperature must rise 5°F above the setpoint of the thermostat to stop the furnace and start the heat pump again.

NOTE: See manual 2100-057 "Heat Pump Sizing" for procedure to determine correct balance point.

The emergency heat switch allows for manual cutoff of the heat pump and operation of the furnace at any outdoor temperature.

NOTE ON BLOWER OPERATION

Because of the design of the heat pump wall thermostats, and the fact that a cooling blower relay is installed in parallel with the fan side of the combination fan/limit control found on most gas or oil furnaces, the furnace blower will start as soon as the wall thermostat calls for heat except in emergency heat mode. This is required for the heat pump and will also occur during the time when the heat pump is off and the furnace is operating. This is contrary to normal blower operation on a gas or oil furnace and is sometimes misunderstood, but an inherent part of the system operation. While in the gas or oil furnace mode of operation, there will still be a run-on in blower operation until the bonnet temperature cools down to the blower off setting of the fan/limit switch.

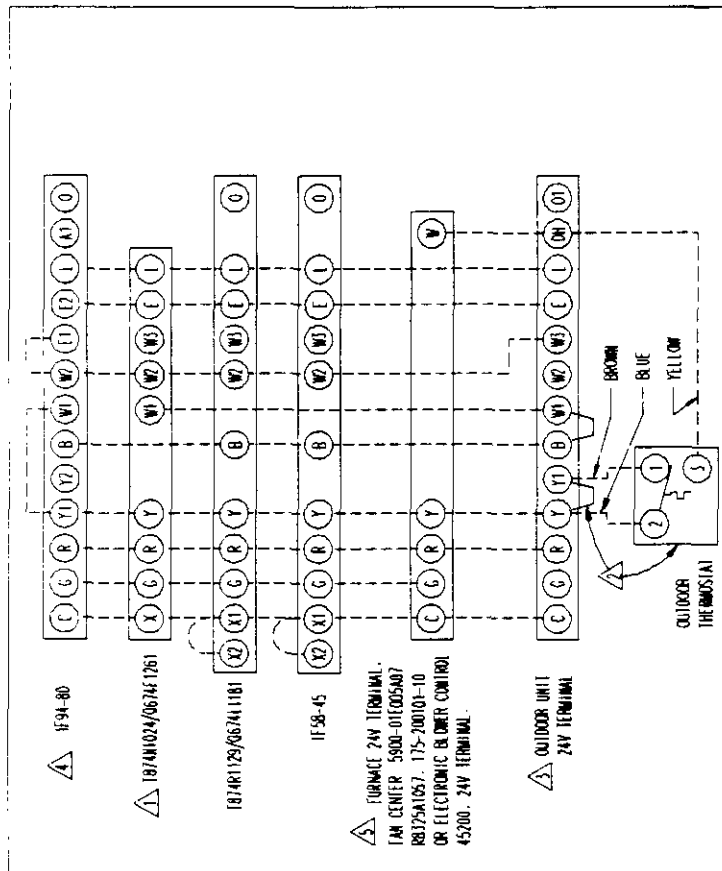

1F94-80

1874M1024/0674E1761

1874R1129/0674E1181

1F58-45

FURNACE 24V TERMINAL.
FAN CENTER 5900-01E05A07
R832A1057, 175-200101-10
OR ELECTRONIC BURNER CONTROL
45200, 24V TERMINAL.

OUTDOOR UNIT
24V TERMINAL

OUTDOOR THERMOSTAT

BROWN
BLUE
YELLOW

SET ADJUST HEAT ANTICIPATOR (SEE FURNACE INSTALLATION INSTRUCTIONS)

WHEN OUTDOOR THERMOSTATE (USED AS CHANGEOVER THERMOSTAT) IS INSTALLED, REMOVE JUMPER Y-11.

IF ITS DESIRED NOT TO ALLOW FURNACE TO CYCLE "ON" DURING DEFROST, A 24V FACTORY WIRE ON TERMINAL ② OF HEATPUMP CONTROL AND TERMINAL ③ ON TERMINAL BOARD MUST BE REMOVED.

OPTION SWITCH SETTING

ON

SWITCH #1 "OFF"
SWITCH #2 "OFF"
SWITCH #3 "OFF"
SWITCH #4 SEE THERMOSTAT INSTALLATION INSTRUCTIONS

HEAT PUMP W/GAS FURNACE

IF THE FURNACE IS NOT INTERNALLY WIRED FOR AND ON AIR CONDITIONING, A FAN CENTER WILL NEED TO BE ADDED.

FACTORY WIRING	FIELD WIRING
LOW VOLTAGE	---
HIGH VOLTAGE	---

4891-200 C

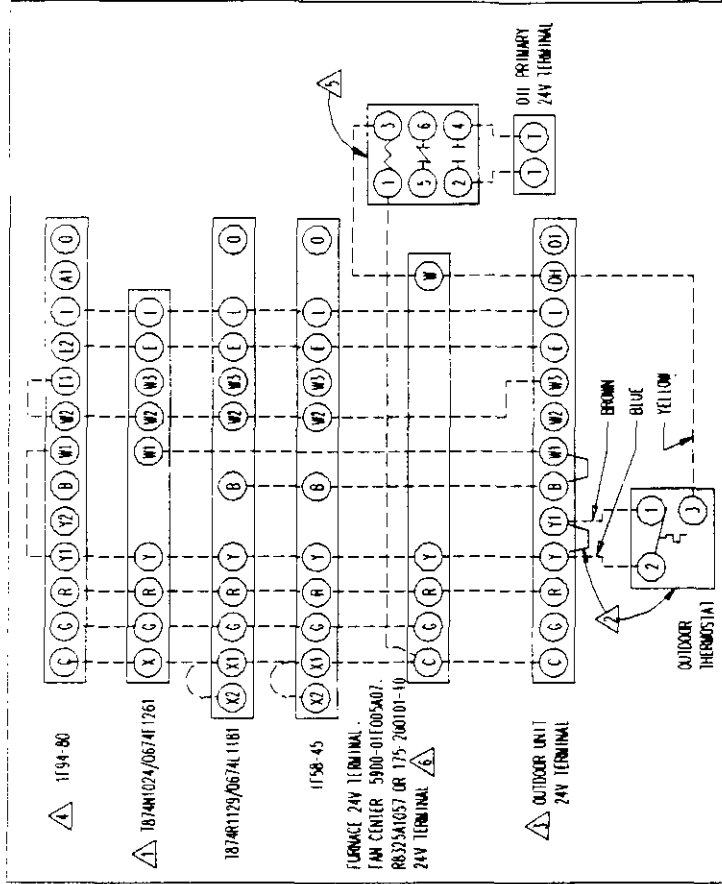

1F94-80

1874M1024/0674E1761

1874R1129/0674E1181

1F58-45

FURNACE 24V TERMINAL.
FAN CENTER 5900-01E05A07
R832A1057 OR 175-200101-10
24V TERMINAL.

OUTDOOR UNIT
24V TERMINAL

OUTDOOR THERMOSTAT

BROWN
BLUE
YELLOW

SET ADJUST HEAT ANTICIPATOR (SEE FURNACE INSTALLATION INSTRUCTIONS)

WHEN OUTDOOR THERMOSTATE (USED AS CHANGEOVER THERMOSTAT) IS INSTALLED, REMOVE JUMPER Y-11.

IF ITS DESIRED NOT TO ALLOW FURNACE TO CYCLE "ON" DURING DEFROST, A 24V FACTORY WIRE ON TERMINAL ② OF HEATPUMP CONTROL AND TERMINAL ③ ON TERMINAL BOARD MUST BE REMOVED.

OPTION SWITCH SETTING

ON

SWITCH #1 "OFF"
SWITCH #2 "OFF"
SWITCH #3 "OFF"
SWITCH #4 SEE THERMOSTAT INSTALLATION INSTRUCTIONS

HEAT PUMP W/OIL FURNACE

LOCATE ISOLATING RELAY IN OIL FURNACE NECESSARY TO SEPARATE 24V POWER SUPPLY OF HEATPUMP FROM 24V POWER SUPPLY BUILT INTO OIL BURNER PRIMARY CONTROL.

IF THE FURNACE IS NOT INTERNALLY WIRED FOR AND ON AIR CONDITIONING, A FAN CENTER WILL NEED TO BE ADDED.

FACTORY WIRING	FIELD WIRING
LOW VOLTAGE	---
HIGH VOLTAGE	---

4891-200 C

CHARGING INSTRUCTIONS

PRESSURE SERVICE PORTS

High and low pressure service ports are installed on all units so that the system operating pressures can be observed. Pressure tables can be found later in the manual covering all models. It is imperative to match the correct pressure table to the unit by model number.

The pressure service ports on the split system heat pump are located on the interconnecting tubing quick connect fittings. An additional low side service port is located on the quick connect mounting plate for low side pressure during heating operation.

THREE PHASE SCROLL COMPRESSOR START UP INFORMATION

Scroll compressors, like several other types of compressors, will only compress in one rotational direction. Direction of rotation is not an issue with single phase compressors since they will always start and run in the proper direction.

However, three phase compressors will rotate in either direction depending upon phasing of the power. Since there is a 50-50 chance of connecting power in such a way as to cause rotation in the reverse direction, verification of proper rotation must be made. Verification of proper rotation direction is made by observing that suction pressure drops and discharge pressure rises when the compressor is energized. Reverse rotation also results in an elevated sound level over that with correct rotation, as well as, substantially reduced current draw compared to tabulated values.

There is no negative impact on durability caused by operating three phase Compliant Scroll compressors in the reversed direction. However, after several minutes of operation, the compressor's internal protector will trip.

All three phase compressors are wired identically internally. As a result, once the correct phasing is determined for a specific system or installation, connecting properly phased power leads to the same Fusite terminals should maintain proper rotation direction.

The direction of rotation of the motor may be changed by reversing any two line connections to the unit.

SYSTEM START UP

STEP 1—Close Disconnect switch(es) and set the thermostat to cool and the temperature to the highest setting.

STEP 2—Check for proper airflow across the indoor

coil by referring to indoor unit installation instructions.

STEP 3—Connect the service gauges and allow the unit to run for at least 10 minutes or until pressures are stable. Check pressures to the system pressure table attached to the outdoor unit service panel. For optimum system performance in cooling, go to step 4.

These start up instructions are for charging system in cooling mode only at 70° outdoor temperature or higher. For outdoor temperatures below 70° and for heating mode, system should only be charged by weight method (see table 11).

STEP 4—Install a thermometer on the suction line approximately 6" to 10" from the compressor. Optimum system performance will occur with a refrigerant charge resulting in a suction line superheat as determined from the following calculations.

- A. Measure outdoor air dry temp. _____ °F
- B. Measure indoor air wet bulb temp. _____ °F
- C. Measure suction pressure _____ psig
- D. Measure suction line temp. _____ °F
- E. Determine optimum system superheat from TABLE 10 using outdoor air dry bulb (Step B) and indoor air wet bulb (Step A). _____ °F
- F. Determine saturated suction pressure using TABLE 9 _____ °F
- G. Determine system superheat:
 Suction line temp. (Step D) _____ °F
 - Saturated suction temp (Step F) - _____ °F
 = System superheat = _____ °F
- H. Adjust the system superheat (Step G) to the optimum system superheat (Step E) by adding charge to lower the superheat or removing charge to raise the superheat.
- I. Check final system operating pressures to the system pressure tables as was done in Step 3.

TABLE 9 — SATURATED SUCTION TEMPERATURE (R-22)

Saturated Suction	
Suction Pressure PSIG	Temperature (°F)
50	26
53	28
55	30
58	32
61	34
63	36
65	38
67	39
70	41
73	43
76	45
79	47
82	49
86	51

TABLE 10 — SYSTEM SUPERHEAT

Outdoor Ambient Temperature (°F Dry Bulb)	Return Air Temperature °F—Wet Bulb			
	59	63	67	71
	105	1	1	5
95	1	3	(8)	20
90	1	7	14	26
85	3	9	19	33
80	8	14	25	39
75	10	20	30	42

TOTAL SYSTEM CHARGE FOR SPLIT SYSTEMS

TABLE 11

Outdoor Section	Indoor Section	Total R-22 Charge (Oz.)
24UHPQC	BC24B	121 oz.
	A36AQ-A	123 oz.
30UHPQC	BC36B	136 oz.
	A36AQ-A	123 oz.
	A37AQ-A	144 oz.
36UHPQC	BC36B	177 oz.
	A37AQ-A	186 oz.
42UHPQA	BC48B	180 oz.
	A61AQ-A	186 oz.
48UHPQB	BC48B	202oz.
	A61AQ-A	206 oz.
60UHPQB	BC80B	232 oz.
	A61AQ-A	230 oz.

The above includes 25' of 3/8" diameter liquid line. For other than 25' and other tube sizes, adjust the total charge according to the following schedule.

TABLE 12

Liquid Line Diameter	Oz. R-22 Per Ft. ①
3/8"	.8
1/2"	1.2

Installer Note: Stamp or mark the final system charge determined above on the outdoor unit serial plate.

- ① These values should only be applied during initial system charging. System operating charge should be adjusted in cooling mode for optimum performance outlined in the installation instructions for that model outdoor section.

TABLE 13—TUBING CHART

Basic Condensing Unit Model	Refrigerant Line Length (Ft.)					
	0 - 20		21 - 60		61 - 100	
	Liquid	Suction	Liquid	Suction	Liquid	Suction
24UHP	3/8"	5/8"	3/8"	3/4"	3/8"	3/4"
30UHP	3/8"	5/8"	3/8"	3/4"	3/8"	3/4"
36UHP	3/8"	5/8"	3/8"	3/4"	1/2"	7/8"
42UHP	3/8"	7/8"	3/8"	7/8"	1/2"	1-1/8"
48UHP	3/8"	7/8"	3/8"	7/8"	1/2"	1-1/8"
60UHP	3/8"	7/8"	3/8"	7/8"	1/2"	1-1/8"

The basis for selection is to maintain adequate velocity which assures adequate oil return to the compressor, an acceptable pressure drop to assure compressor capacity, and minimum tubing costs.

These recommendations are based on the use of standard refrigeration tubing.

Line sizes listed are outside tube dimensions.

These suggestions do not include consideration for additional pressure drop due to elbows, valves, or reduced joint sizes.

These recommendations are to be applied to approved combinations of Bard outdoor and indoor sections only.

SERVICE

SERVICE HINTS

1. Caution homeowner to maintain clean air filters at all times. Also, not to needlessly close off supply and return air registers. This reduces air flow through the system, which shortens equipment service life as well as increasing operating costs.
2. Switching to heating cycle at 75°F or higher outside temperature may cause a nuisance trip of the reset high pressure switch.
3. The heat pump wall thermostats perform multiple functions. Be sure that all function switches are correctly set for the desired operating mode before trying to diagnose any reported service problems.
4. Check all power fuses or circuit breakers to be sure that they are the correct rating.
5. Periodic cleaning of the outdoor coil to permit full and unrestricted air flow circulation is essential.

FAN BLADE SETTING DIMENSIONS

Shown in the drawing below are the correct fan blade setting dimensions for proper air delivery across the outdoor coil.

Any service work requiring removal or adjustment in the fan and/or motor area will require that the dimensions below be checked and blade adjusted in or out on the motor shaft accordingly.

FIGURE 8

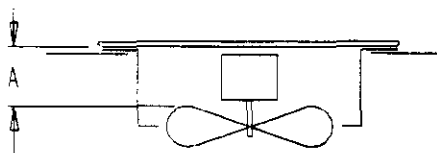

TABLE 14—DIMENSIONS

Model	Dimension A (Inches)
24UHPQC	3-1/2"
30UHPQC	
36UHPQC	
42UHPQA	4"
48UHPQB	
60UHPQB	

DISCHARGE TEMPERATURE

Some scroll compressors are equipped with discharge temperature sensor located on the outside top of the compressor. The sensor is a SPST thermostat which opens when the discharge temperature exceeds 280°F + 8°F on a temperature rise. When the switch opens, the

circuit to the compressor contactor is de-energized and the unit shuts off. The switch automatically resets when the compressor temperature drops below 130°F + 14°F.

The sensor can be accessed by prying on the snap plug on top of the compressor. See FIGURE 7. Make sure to securely reseal the sensor after replacement. The sensor terminals are located outside the compressor terminal box. FIGURE 8 shows the arrangement of compressor line voltage terminals and discharge sensor terminals.

FIGURE 9—DISCHARGE TEMPERATURE SENSOR

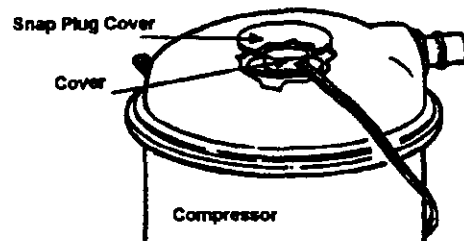
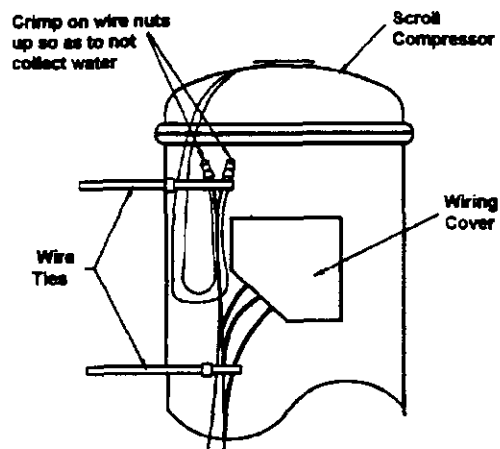

FIGURE 10



CRANKCASE HEATERS

Some 3 phase models have a wraparound type heater located on the lower section of the compressor housing. This heater draws only enough power to maintain the compressor at a safe temperature when the compressor is not running.

Some form of crankcase heat is essential to prevent liquid refrigerant migrating to the compressor causing oil pump out on compressor start-up.

The decal in FIGURE 9 is affixed to all outdoor units detailing start-up procedure. This is very important. Please read carefully.

FIGURE 11

IMPORTANT

THESE PROCEDURES MUST BE FOLLOWED AT INITIAL START-UP AND AT ANY TIME POWER HAS BEEN REMOVED FOR 12 HOURS OR LONGER.

TO PREVENT COMPRESSOR DAMAGE WHICH MAY RESULT FROM THE PRESENCE OF LIQUID REFRIGERANT IN THE COMPRESSOR CRANKCASE.

1. MAKE CERTAIN THE ROOM THERMOSTAT IS IN THE "OFF" POSITION (THE COMPRESSOR IS NOT TO OPERATE).
2. APPLY POWER BY CLOSING THE SYSTEM DISCONNECT SWITCH THIS ENERGIZES THE COMPRESSOR HEATER WHICH EVAPORATES THE LIQUID REFRIGERANT IN THE CRANKCASE.
3. ALLOW 4 HOURS OR 60 MINUTES PER POUND OF REFRIGERANT IN THE SYSTEM AS NOTED ON THE UNIT RATING PLATE, WHICHEVER IS GREATER.
4. AFTER PROPERLY ELAPSED TIME THE THERMOSTAT MAY BE SET TO OPERATE THE COMPRESSOR.
5. EXCEPT AS REQUIRED FOR SAFETY WHILE SERVICING — **DO NOT OPEN SYSTEM DISCONNECT SWITCH.**

7961-061

COMPRESSOR SHORT CYCLE PROTECTION

The solid state heat pump control included with this model has a built in compressor short cycle protection that will prevent the compressor from restarting until compressor has been off for at least five minutes. There is a speed up jumper on the heat pump control that can be used to reduce this time for service of equipment.

DEFROST CYCLE

The defrost cycle is controlled by temperature and time on the solid state heat pump control.

When the outdoor temperature is in the lower 40°F temperature range or colder, the outdoor coil temperature is 32°F or below. This coil temperature is sensed by the defrost thermostat mounted near the bottom of the outdoor coil. Once the coil temperature reaches 32°F or below, the defrost thermostat closes and the defrost timer will start.

After 60 (90 or 30) minutes at 32°F or below, the heat pump control will place the system in the defrost mode.

During the defrost mode, the refrigerant cycle switches back to the cooling cycle, the outdoor motor stops, electric heaters are energized, and hot gas passing through the outdoor coil melts any accumulator frost. When the temperature rises to approximately 57°F, the defrost thermostat will open which will return the system to heating operations automatically.

If some abnormal or temporary condition such as high wind causes the heat pump to have a prolonged defrost cycle, the heat pump control will restore the system to heating operation automatically after 10 minutes.

There are three settings on the heat pump control—30 minutes, 60 minutes, and 90 minutes. Most models are shipped wired on the 60 minute setting for greatest operating economy. If special circumstances require a change to another time, remove wire connected to terminal 60 and reconnect to desired terminal.

There is a cycle speed up jumper on the control. This can be used to reduce the time between defrost cycle operation without waiting for time to elapse.

FIGURE 12—CONTROL CIRCUIT

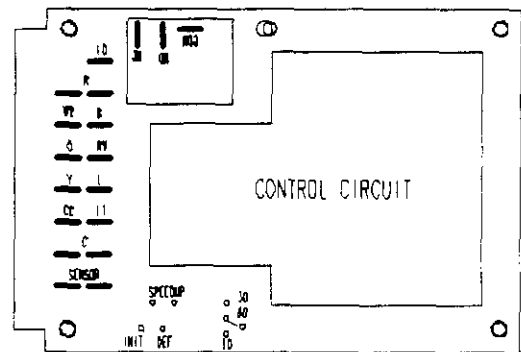

SOLID STATE HEAT PUMP CONTROL TROUBLESHOOTING PROCEDURE

1. Turn on AC power supply to indoor and outdoor units.
2. Turn thermostat blower switch to fan on—the indoor blower should start. (If it doesn't, troubleshoot indoor unit and correct problem.)
3. Turn thermostat blower switch to auto position. Indoor blower should stop.
4. Set system switch to heat or cool. Adjust thermostat to call for heat or cool—the indoor blower, compressor, and outdoor fan should start.

NOTE: If there was no power to 24 volt transformer, the compressor and outdoor fan will not start for 5 minutes. This is because of the compressor short cycle protection.

TABLE 15 — TROUBLESHOOTING PROCEDURES

Symptom	Possible Causes	What to Check	How to Check or Repair
Compressor contactor does not energize (cooling or heating)	Control circuit wiring	Check for R connection at outdoor unit, and 24V between R-C. 1. Check for 24V between L1-C on heat pump control	Run R connection to outdoor unit to power heat pump control 1. If no voltage between L1-C turn, thermostat off and on again to reset high pressure switch. 2. If high pressure switch is open and will not reset, replace high pressure switch.
	Compressor lock out	2. Check across high pressure switch	
Fan outdoor motor does not run (cooling or heating except during defrost)	Compressor short cycle protection	Check for 24V between CC-C and Y-C on heat pump control	1. If no voltage between CC-C jumper speed up terminal and within 10 seconds power should appear between CC-C. Remove speed up jumper after 10 seconds. Replace heat pump control.
	Heat pump control defective	Check all other possible causes. Manual 2100-065.	Replace heat pump control.
	Contactors defective	Check for open or shorted coil winding	Replace contactor.
	Motor defective	Check for open or shorted motor winding	Replace motor.
Reversing valve does not energize (heating only).	Motor capacitor defective	Check capacitor rating. Check for open or shorted capacitor.	Replace capacitor.
	Heat pump control defective	Check across fan relay on heat pump control. (Com-NC)	Replace pump control.
	Reversing valve solenoid coil defective	Check for open or shorted coil.	Replace solenoid coil.
Unit will not go into defrost (heating only)	Heat pump control defective	Check for 24V between RV-C and B-C. Disconnect defrost thermostat and jumper across sensor terminals. This should cause the unit to go through a defrost cycle within one minute.	1. Check control circuit wiring. 2. Replace heat pump control.
	Heat pump control defective	Jumper across speed up terminals. This should cause the unit to come out of defrost within one minute.	1. If unit goes through defrost cycle, check defrost thermostat. 2. If unit does not go through defrost cycle, replace heat pump control.
Unit will not come out of defrost (heating only)	Heat pump control defective	Jumper across speed up terminals. This should cause the unit to come out of defrost within one minute.	1. If unit comes out of defrost cycle, check defrost thermostat. 2. If unit does not come out of defrost cycle, replace heat pump control.

**OUTDOOR MODEL
24UHPQC**

COOLING

Indoor Model	Return Air Temperature	Pressure	Air Temperature Entering Outdoor Coil °F								
			75°	80°	85°	90°	95°	100°	105°	110°	115°
BC24B	75° DB	Low Side	68	71	73	75	77	78	79	80	80
	62° WB	High Side	158	170	185	200	215	231	248	265	283
Rated	80° DB	Low Side	74	78	78	80	82	83	85	85	86
	67° WB	High Side	161	175	190	205	221	237	254	272	290
CFM 800	85° DB	Low Side	80	82	84	86	88	90	91	92	93
	72° WB	High Side	166	181	196	212	229	246	263	282	300
A36AQ-A	75° DB	Low Side	69	72	74	76	78	79	80	80	80
	62° WB	High Side	155	170	185	200	216	232	248	264	281
A36AQ-B	80° DB	Low Side	74	77	79	81	83	84	85	86	86
	67° WB	High Side	160	175	190	206	222	238	255	271	286
Rated	85° DB	Low Side	80	83	85	87	89	90	91	92	92
	72° WB	High Side	164	180	197	213	230	247	264	281	298

HEATING

Model	Return Air Temperature	Pressure	Air Temperature Entering Outdoor Coil °F														
			0°	5°	10°	15°	17°	20°	25°	30°	35°	40°	45°	47°	50°	55°	60°
BC24B	70° DB	Low Side	11	17	22	27	29	32	37	42	48	53	58	60	63	68	73
		High Side	152	158	163	169	171	174	180	185	191	196	202	204	207	213	218
CFM 800	70° DB	Low Side	12	17	22	27	29	32	37	42	47	52	57	59	62	67	60
		High Side	151	157	162	167	169	172	177	182	188	193	198	200	203	208	213

**OUTDOOR MODEL
30UHPQC**

COOLING

Indoor Model	Return Air Temperature	Pressure	Air Temperature Entering Outdoor Coil °F								
			75°	80°	85°	90°	95°	100°	105°	110°	115°
BC36B	75° DB	Low Side	68	70	72	74	75	78	77	78	78
	62° WB	High Side	165	179	194	209	224	240	256	273	290
Rated	80° DB	Low Side	73	75	77	79	80	81	82	83	83
	67° WB	High Side	170	184	200	214	230	246	263	280	297
CFM 1050	85° DB	Low Side	79	81	83	85	86	87	88	89	89
	72° WB	High Side	176	191	206	222	238	255	272	289	307
A36AQ-A	75° DB	Low Side	68	69	71	73	74	75	77	78	79
	62° WB	High Side	164	178	193	209	225	242	259	277	296
Rated	80° DB	Low Side	73	74	76	77	79	81	82	84	85
	67° WB	High Side	168	183	198	214	231	248	266	285	304
CFM 1050	85° DB	Low Side	79	80	82	83	85	87	88	90	91
	72° WB	High Side	175	190	205	222	239	257	276	295	315
A37AQ-A	75° DB	Low Side	71	73	75	77	78	79	80	80	80
	62° WB	High Side	167	182	197	212	228	244	260	276	293
Rated	80° DB	Low Side	76	78	80	82	83	84	85	86	88
	67° WB	High Side	172	187	202	218	234	250	267	284	301
CFM 1050	85° DB	Low Side	82	84	88	88	89	90	91	92	92
	72° WB	High Side	179	194	209	226	242	259	276	294	312

HEATING

Model	Return Air Temperature	Pressure	Air Temperature Entering Outdoor Coil °F														
			0°	5°	10°	15°	17°	20°	25°	30°	35°	40°	45°	47°	50°	55°	60°
BC36B Rated	70° DB	Low Side	11	16	20	25	27	30	34	39	44	48	53	55	58	62	67
		High Side	145	151	157	163	165	169	175	181	187	193	199	201	205	211	217
A36AQ-A Rated	70° DB	Low Side	10	15	19	24	26	29	33	38	43	47	52	54	57	61	66
		High Side	158	164	170	178	178	182	187	193	199	205	211	213	217	222	228
A37AQ-A Rated	70° DB	Low Side	9	14	19	24	26	29	34	39	44	49	54	56	59	64	69
		High Side	146	151	155	160	162	165	169	174	179	183	188	190	193	197	202

Low side pressure ± 2 PSIG (suction service port @ quick support plate)

High side pressure ± 5 PSIG (location line @ outdoor unit quick connect)

Tables are based upon rated CFM (airflow) across the evaporator coil and should be found under section titled "Refrigerant Charge" elsewhere in manual. If there is any doubt as to correct operating charge being in the system, the charge should be removed, system evacuated, and recharged to serial plate instructions.

**OUTDOOR MODEL
36UHPQC**

COOLING			Air Temperature Entering Outdoor Coil °F									
Indoor Model	Return Air Temperature	Pressure	75°	80°	85°	90°	95°	100°	105°	110°	115°	
BC36B	75° DB	Low Side	66	68	70	72	73	74	75	76	76	
	62° WB	High Side	165	182	199	217	235	253	272	291	311	
Rated CFM 1200	80° DB	Low Side	71	73	75	77	78	79	80	81	81	
	67° WB	High Side	170	187	205	223	241	260	279	299	319	
A37AQ-A	75° DB	Low Side	66	69	71	73	75	76	77	78	78	
	62° WB	High Side	174	189	204	220	236	253	270	287	305	
Rated CFM 1200	80° DB	Low Side	71	74	76	78	80	81	82	83	83	
	67° WB	High Side	179	194	209	225	242	259	277	295	313	
1200	85° DB	Low Side	77	80	83	85	87	89	90	91	92	
	72° WB	High Side	184	200	217	234	251	269	287	305	324	

HEATING			Air Temperature Entering Outdoor Coil °F															
Model	Return Air Temperature	Pressure	0°	5°	10°	15°	17°	20°	25°	30°	35°	40°	45°	47°	50°	55°	60°	
BC36B	70° DB	Low Side	10	15	19	24	26	29	33	38	43	47	52	54	57	61	66	
		High Side	163	170	177	183	186	190	197	203	210	217	223	226	230	237	243	
A37AQ-A	70° DB	Low Side	10	14	19	24	26	29	34	39	43	48	53	55	58	63	68	
		High Side	155	162	169	176	179	183	190	197	204	211	218	221	225	232	239	

**OUTDOOR MODEL
42UHPQA**

COOLING			Air Temperature Entering Outdoor Coil °F									
Indoor Model	Return Air Temperature	Pressure	75°	80°	85°	90°	95°	100°	105°	110°	115°	
BC48B	75° DB	Low Side	71	72	74	75	76	77	78	78	79	
	62° WB	High Side	178	194	210	226	243	260	278	296	314	
Rated CFM 1525	80° DB	Low Side	76	77	79	80	81	82	83	83	84	
	67° WB	High Side	183	199	216	233	250	268	285	304	322	
1525	85° DB	Low Side	82	83	85	86	87	88	89	89	90	
	72° WB	High Side	189	206	223	241	259	277	296	314	333	
A61AQ-A	75° DB	Low Side	76	77	79	80	81	82	82	83	83	
	62° WB	High Side	190	204	219	235	252	270	288	307	327	
Rated CFM 1525	80° DB	Low Side	82	83	85	86	87	88	88	89	89	
	67° WB	High Side	195	210	225	242	259	277	296	316	336	
1525	85° DB	Low Side	87	89	91	93	94	95	96	96	96	
	72° WB	High Side	203	218	234	250	268	287	306	327	348	

HEATING			Air Temperature Entering Outdoor Coil °F															
Model	Return Air Temperature	Pressure	0°	5°	10°	15°	17°	20°	25°	30°	35°	40°	45°	47°	50°	55°	60°	
BC48B	70° DB	Low Side	11	16	20	24	26	29	33	37	42	47	51	53	56	60	65	
		High Side	147	153	160	166	168	172	177	183	188	193	198	200	203	207	212	
A61AQ-A	70° DB	Low Side	21	22	24	27	28	30	33	37	42	47	53	55	59	65	72	
		High Side	156	158	161	165	166	168	172	176	180	184	189	191	194	199	204	

Low side pressure ± 2 PSIG (suction service port ⓐ quick support plate)

High side pressure ± 5 PSIG (location line ⓑ outdoor unit quick connect)

Tables are based upon rated CFM (airflow) across the evaporator coil and should be found under section titled "Refrigerant Charge" elsewhere in manual. If there is any doubt as to correct operating charge being in the system, the charge should be removed, system evacuated, and recharged to serial plate instructions.

OUTDOOR MODEL
48UHPQB
48UHPQB-B

COOLING			Air Temperature Entering Outdoor Coil °F									
Indoor Model	Return Air Temperature	Pressure	75°	80°	85°	90°	95°	100°	105°	110°	115°	
BC48B	75° DB	Low Side	65	67	69	71	72	73	74	75	76	
	62° WB	High Side	194	210	227	244	262	280	298	317	336	
Rated CFM 1700	80° DB	Low Side	70	72	74	76	77	78	79	80	81	
	67° WB	High Side	199	216	233	251	269	287	306	325	345	
A61AQ-A	85° DB	Low Side	75	77	79	81	83	84	86	86	87	
	72° WB	High Side	207	224	242	260	278	297	316	336	357	
Rated CFM 1650	75° DB	Low Side	71	73	75	77	78	79	80	80	80	
	62° WB	High Side	199	218	236	254	272	290	307	324	341	
A61AQ-A	80° DB	Low Side	76	78	80	82	83	84	85	86	86	
	67° WB	High Side	205	223	242	261	279	297	315	333	350	
Rated CFM 1650	85° DB	Low Side	82	84	86	88	89	90	91	92	92	
	72° WB	High Side	211	231	251	270	289	308	326	344	362	

HEATING			Air Temperature Entering Outdoor Coil °F															
Model	Return Air Temperature	Pressure	0°	5°	10°	15°	17°	20°	25°	30°	35°	40°	45°	47°	50°	55°	60°	
BC48B	70° DB	Low Side	8	13	18	23	25	28	33	37	42	47	51	53	56	60	65	
		High Side	149	157	165	173	176	181	188	196	202	209	215	218	222	228	234	
A61AQ-A	70° DB	Low Side	25	24	24	24	25	26	29	32	37	43	49	52	57	65	75	
		High Side	169	189	171	173	174	178	180	185	191	198	206	206	214	224	235	

OUTDOOR MODEL
60UHPQB
60UHPQB-B

COOLING			Air Temperature Entering Outdoor Coil °F									
Indoor Model	Return Air Temperature	Pressure	75°	80°	85°	90°	95°	100°	105°	110°	115°	
BC60B	75° DB	Low Side	65	68	68	70	71	72	74	75	76	
	62° WB	High Side	191	208	225	243	260	277	295	312	330	
Rated CFM 1800	80° DB	Low Side	70	71	73	75	76	77	79	80	81	
	67° WB	High Side	196	214	232	249	267	285	303	321	339	
A61AQ-A	85° DB	Low Side	74	76	78	80	82	84	85	86	87	
	72° WB	High Side	204	222	240	258	276	294	313	332	351	
Rated CFM 1800	75° DB	Low Side	64	66	68	70	71	72	73	74	75	
	62° WB	High Side	190	206	223	240	257	275	293	311	330	
A61AQ-A	80° DB	Low Side	69	71	73	75	76	77	78	79	80	
	67° WB	High Side	196	212	229	246	264	282	301	320	339	
Rated CFM 1800	85° DB	Low Side	74	76	78	80	82	83	85	85	86	
	72° WB	High Side	202	219	237	255	273	292	311	331	351	

HEATING			Air Temperature Entering Outdoor Coil °F															
Model	Return Air Temperature	Pressure	0°	5°	10°	15°	17°	20°	25°	30°	35°	40°	45°	47°	50°	55°	60°	
BC60B	70° DB	Low Side	15	18	21	25	26	28	32	36	41	46	51	53	56	62	68	
		High Side	156	160	164	168	170	173	179	185	192	199	206	211	216	226	235	
A61AQ-A	70° DB	Low Side	19	20	22	25	26	28	31	35	40	45	51	53	57	63	70	
		High Side	169	175	181	187	190	194	201	208	215	222	230	233	238	246	254	

Low side pressure ± 2 PSIG (suction service port @ quick support plate)

High side pressure ± 5 PSIG (location line @ outdoor unit quick connect)

Tables are based upon rated CFM (airflow) across the evaporator coil and should be found under section titled "Refrigerant Charge" elsewhere in manual. If there is any doubt as to correct operating charge being in the system, the charge should be removed, system evacuated, and recharged to serial plate instructions.

CONNECTION DIAGRAM

DANGER: ELECTRICAL SHOCK HAZARD.
DISCONNECT POWER BEFORE SERVICING

TONS (ACM)	COMP. CONTACTOR
2	40-5/570
2-1/2	45-5/570
3	50-5/570

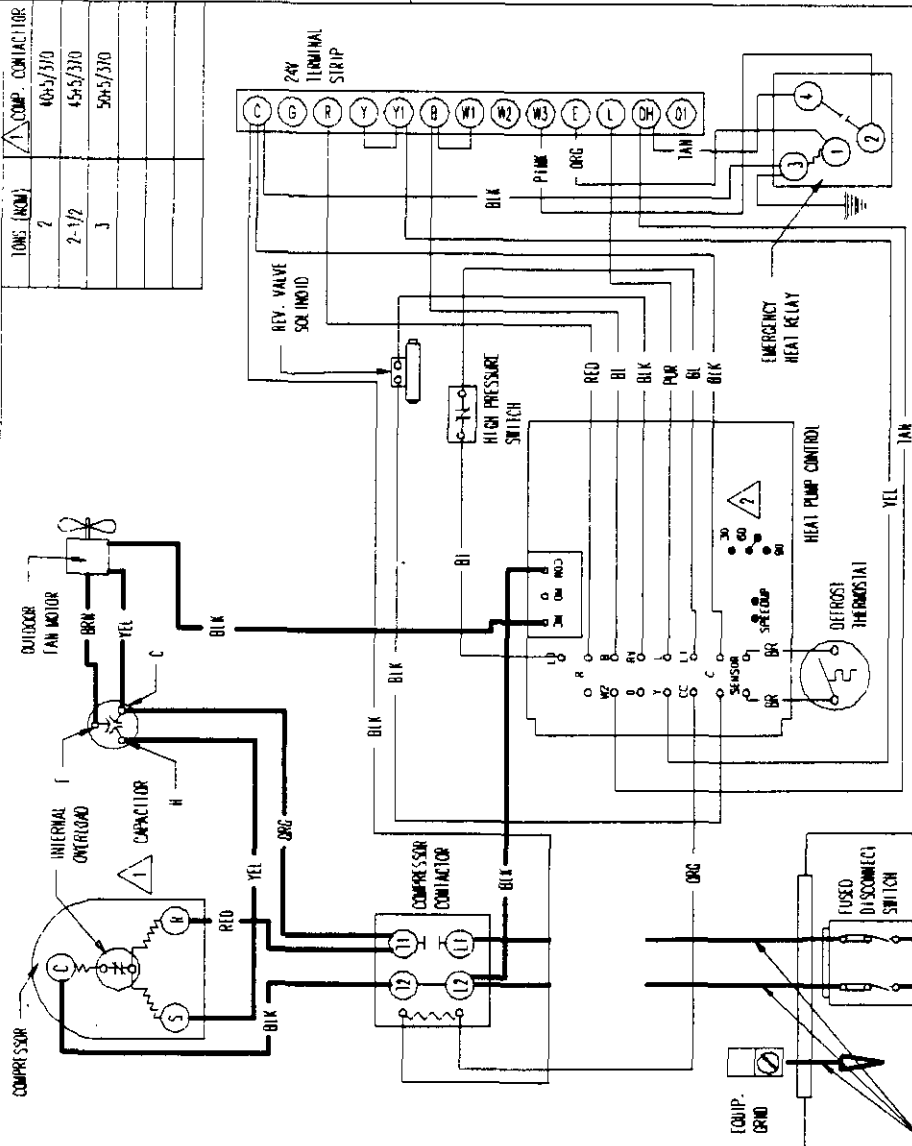

1 - Low Voltage
2 - High Voltage

FACTORY WIRING
FIELD WIRING

FACTORY SET ON 60 MIN. CYCLE
RECONNECT TO 30 FOR 50 MIN. CYCLE
RECONNECT TO 90 FOR 90 MIN. CYCLE

LADDER DIAGRAM

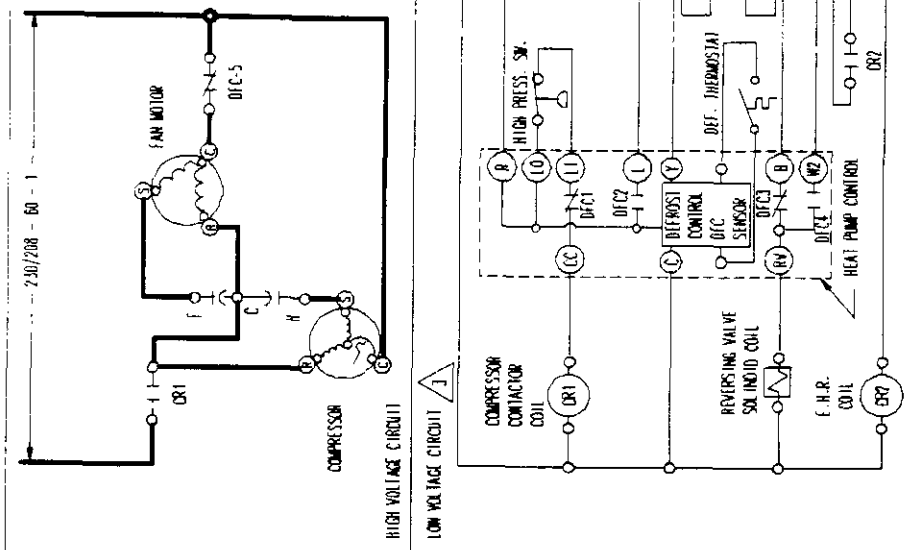

3 - 24 VOLTS FOR LOW VOLTAGE CONTROL CIRCUIT SUPPLIED BY INDOOR UNIT TRANSFORMER

CONNECTION DIAGRAM

DANGER: ELECTRICAL SHOCK HAZARD.
DISCONNECT POWER BEFORE SERVICING

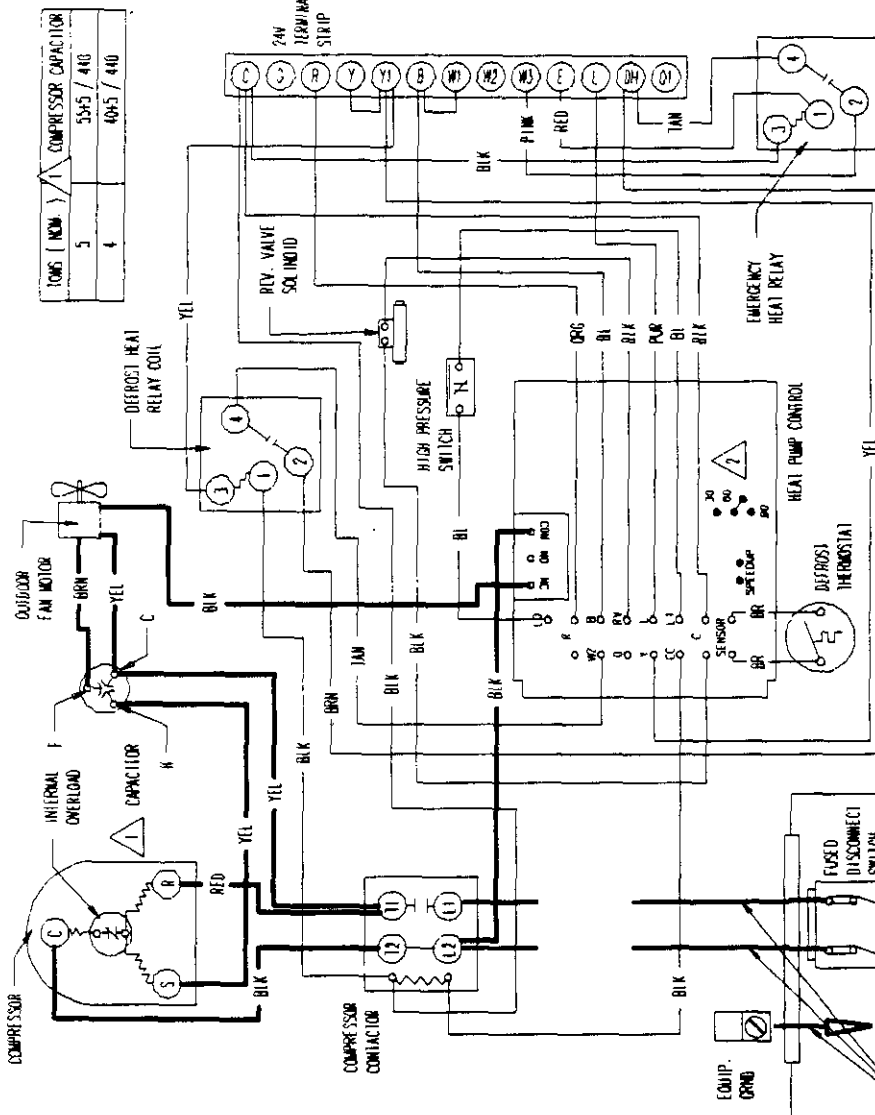

FACTORY WIRING
FIELD WIRING

Low Voltage
High Voltage

2. FACTORY SET ON 60 MIN. CYCLE
RECONNECT TO 30 FOR 30 MIN. CYCLE
RECONNECT TO 90 FOR 90 MIN. CYCLE

LADDER DIAGRAM

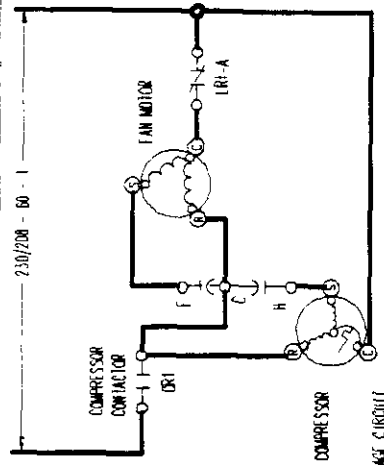

HIGH VOLTAGE CIRCUIT

LOW VOLTAGE CIRCUIT

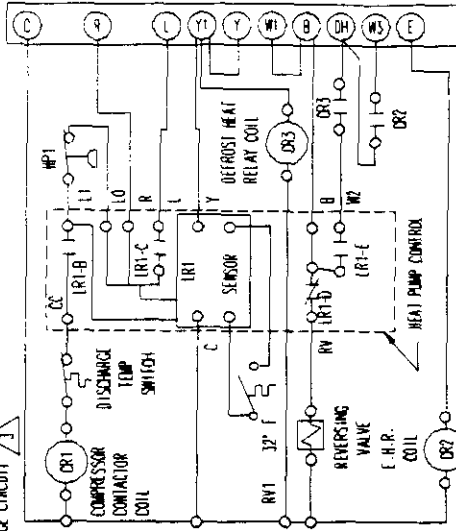

3. 24 VOLTS FOR LOW VOLTAGE CONTROL CIRCUIT SUPPLIED BY INDOOR UNIT TRANSFORMER

4087 113-1

AIR SOURCE HEAT PUMP PERFORMANCE REPORT

This performance check report should be filled out by installer and retained with unit.

DATE: _____ TAKEN BY: _____

1. OUTDOOR UNIT:
Mfgr. _____ Model No. _____ S/N _____
INDOOR UNIT (Split System):
Mfgr. _____ Model No. _____ S/N _____
2. Person Reporting _____
3. Company Reporting _____
4. Installed By _____ Date Installed _____
5. User's (Owner's) Name _____
Address _____
6. Unit Location _____

THE FOLLOWING INFORMATION IS NEEDED TO CHECK PERFORMANCE OF UNIT.

OUTDOOR SIDE DATA		Cooling	Heating	
7.	Entering temperature	_____	_____	F
8.	Liquid or discharge line pressure	_____	PSIG _____	
9.	Suction line pressure	_____	PSIG _____	
10.	Voltage at compressor (unit running)	_____	_____	V
11.	Amperage draw at line side of contactor	_____	_____	A
12.	Amperage at compressor common terminal	_____	_____	A
13.	Suction line temperature 6" from compressor	_____	_____	F
14.	Superheat at compressor	_____	_____	F
15.	Liquid line temperature at metering device	_____	_____	F
16.	Coil subcooling	_____	_____	F
INDOOR SIDE DATA		Cooling	Heating	
17.	Dry bulb temperature at air entering indoor coil	_____	_____	F
18.	Wet bulb temperature of air entering indoor coil	_____	_____	F
19.	Dry bulb temperature of air leaving indoor coil	_____	_____	F
20.	Wet bulb temperature of air leaving indoor coil	_____	_____	F
21.	Indoor fan motor operating voltage (split system only)	_____	_____	V
22.	Indoor fan motor operating amperage	_____	_____	A
23.	*Static pressure drop across indoor coil (split system only)	_____	_____	WC
24.	*Supply air static pressure (packaged unit)	_____	_____	WC
25.	*Return air static pressure (packaged unit)	_____	_____	WC
*Items that are optional.				
26.	Other information about installation	_____		

