

# **INSTALLATION INSTRUCTIONS**

**BC48B and BC60B**

**INDOOR BLOWER COIL UNIT**

**FOR USE WITH  
SPLIT HEAT PUMP AND  
SPLIT AIR CONDITIONER SYSTEMS**

**MANUAL 2100-179 REV. B  
SUPERSEDES REV. A  
FILE VOL. I, TAB 6**

## TABLE OF CONTENTS

I.	APPLICATION AND LOCATION . . . . .	7
	General . . . . .	7
	Unpacking . . . . .	7
	Application . . . . .	7
	Ductwork . . . . .	7
	Location and Clearances . . . . .	8
	Mounting Position . . . . .	8
	Expansion Device . . . . .	9
	Caution When Using 5780 Series Couplings . . . . .	10
	Condensate Drain . . . . .	11
II.	WIRING . . . . .	11
	Thermostat Low-Voltage Wiring . . . . .	11
	Unit Operation . . . . .	12
	Air Conditioning with Electric Heat . . . . .	12
	Heat Pump with Electric Heat . . . . .	12
	How To Set Adjustable Anticipator . . . . .	13
	Additional Information For Electric Heat or Heat Pump Applications. . . . .	14
III.	SERVICE . . . . .	14
	Two Speed Blower Motor . . . . .	14
	Filter . . . . .	15
	Control Diagrams. . . . .	16
	Wall Thermostats . . . . .	22
	Wiring Diagram . . . . .	23

## FIGURES AND TABLES

Figure 1	. . . . .	1
Figure 2	. . . . .	8
Figure 3	. . . . .	9
Figure 4	. . . . .	10
Figure 5	. . . . .	13
Figure 6	. . . . .	14
Table 1	. . . . .	2
Table 2	. . . . .	3
Table 3	. . . . .	3
Table 4	. . . . .	4
Table 5	. . . . .	4
Table 6	. . . . .	5
Table 7	. . . . .	6
Table 8	. . . . .	6
Table 9	. . . . .	7
Table 10	. . . . .	11
Table 11	. . . . .	12
Table 12	. . . . .	12
Table 13	. . . . .	12
Table 14	. . . . .	22

FIGURE 1

**BC48B AND BC60B SERIES**

Upflow - Counterflow - Horizontal  
2 Speed Direct Drive Motor  
Slide-In Return Air Filter

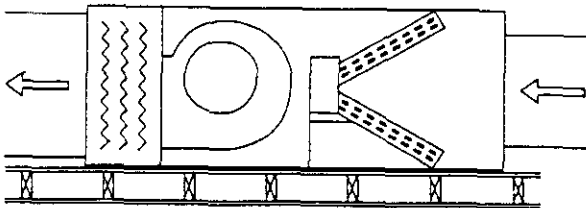

HORIZONTAL (ATTIC OR CRAWL SPACE)  
Requires Field Installed Horizontal  
Drain Pan

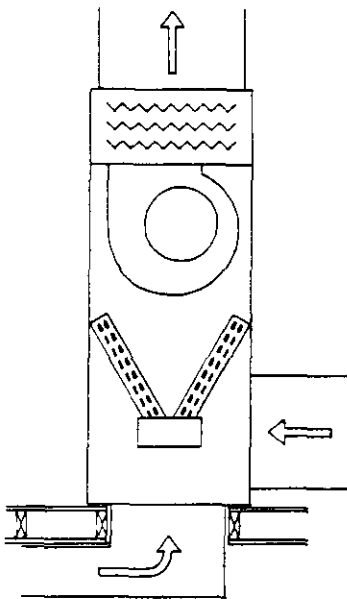
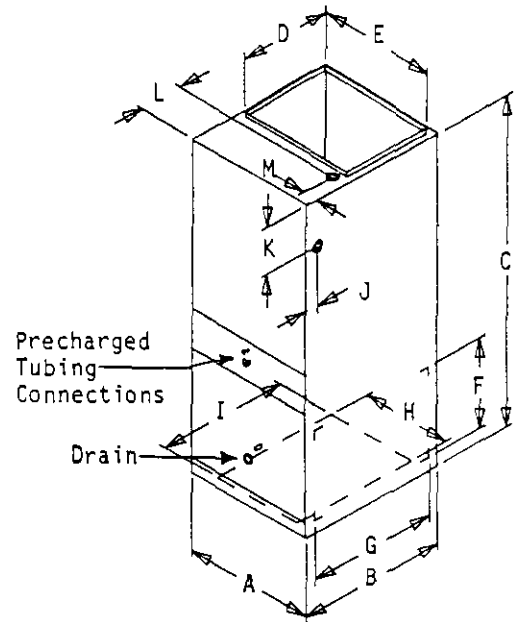

UPFLOW (BOTTOM INLET OR  
SIDE INLET)

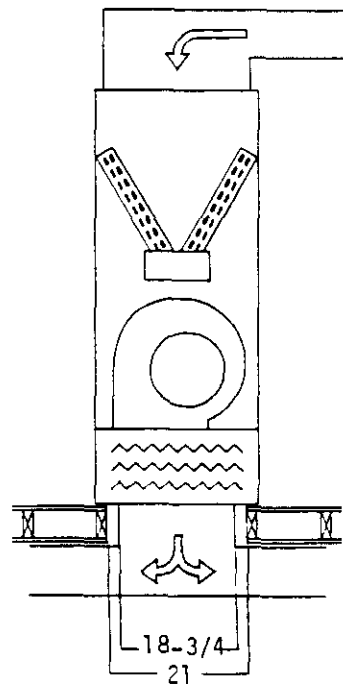

COUNTERFLOW  
Requires Combustible  
Floor Base CFB45A

A 21 x 23  
opening is  
required in  
the floor  
(mounting  
space).

\*\*\*\*\*  
WARNING: Failure to provide the one inch clearance for the first four feet between the supply duct and a  
combustible surface can result in fire.  
\*\*\*\*\*

Model	Cabinet Size			Supply Outlet		Side Return Air Opening		Bottom Return Air Opening		Electrical Openin Right Side		Electrical Openin Top	
	A	B	C	D	E	F	G	H	I	J	K	L	M
BC48B & BC60B	22	28-1/2	58-1/2	18-1/2	21	20	24	20	24	2	7	2	2-1/2

TABLE 1

Model	BC48B	BC48B
Electrical Rating--60HZ --50HZ	240/208-1 PH 240/220-1 PH	240/208-1 PH 240/220-1 PH
Operating Voltage Range	197-253	197-253
Fusing and Ampacity	See Electric Heat Table	
Blower and Motor	10x8 Direct	10x10 Direct
Motor--RPM/Speed	1075/2	1075/2
Motor--HP/AMPS	1/2 / 4.7	1/2 / 4.7
Evaporator Face Area Sq. Ft./Row/Fins Per Inch	8/3/10	8/4/14
Filter--Perm. or Throwaway	20x25x1 T	20x25x1 T
Refrigerant Cont./Orifice	.078	.092
Maximum Electric Heat	18KW	18KW

BLOWER COIL  
MODEL  
BC48B

TABLE 2  
MAXIMUM E.S.P. OPERATION INFORMATION ELECTRIC HEAT ONLY

KW Installed	Upflow Position		Horizontal Position		Counterflow Position	
	Low Speed	High Speed	Low Speed	High Speed	Low Speed	High Speed
0KW	.80	.80	.80	.80	.80	.80
9KW 1PH	.80	.80	.80	.80	.80	.80
14KW 1PH	.80	.80	.80	.80	.80	.80
18KW 1PH	.80	.80	.80	.80	.80	.80
9KW 3PH	.80	.80	.80	.80	.80	.80
18KW 3PH	.80	.80	.80	.80	.80	.80

TABLE 3  
MAXIMUM E.S.P. OPERATION INFORMATION HEAT PUMP HEATING WITH ELECTRIC HEAT

Compressor Section	KW Installed	Upflow Position		Horizontal Position		Counterflow Position	
		Low Speed	High Speed	Low Speed	High Speed	Low Speed	High Speed
42UHPQA 48UHPQA	0KW	.60	.60	.60	.60	.60	.60
42UHPQA 48UHPQA	9KW 1PH	.60	.60	.60	.60	.60	.60
42UHPQA 48UHPQA	14KW 1PH	.60	.60	.60	.60	.60	.60
42UHPQA 48UHPQA	18KW 1PH	.55	.60	.55	.55	.55	.60
42UHPQA 48UHPQA	9KW 3PH	.60	.60	.60	.60	.60	.60
42UHPQA 48UHPQA	18KW 3PH	.55	.55	.55	.55	.55	.55

BLOWER COIL  
MODEL  
BC60B

TABLE 4  
MAXIMUM E.S.P. OPERATION INFORMATION ELECTRIC HEAT ONLY

KW Installed	Upflow Position		Horizontal Position		Counterflow Position	
	Low Speed	High Speed	Low Speed	High Speed	Low Speed	High Speed
0KW	.80	.80	.80	.80	.80	.80
9KW 1PH	.80	.80	.80	.80	.80	.80
14KW 1PH	.80	.80	.80	.80	.80	.80
18KW 1PH	.80	.80	.80	.80	.80	.80
9KW 3PH	.80	.80	.80	.80	.80	.80
18KW 3PH	.80	.80	.80	.80	.80	.80

TABLE 5  
MAXIMUM E.S.P. OPERATION INFORMATION HEAT PUMP HEATING WITH ELECTRIC HEAT

Compressor Section	KW Installed	Upflow Position		Horizontal Position		Counterflow Position	
		Low Speed	High Speed	Low Speed	High Speed	Low Speed	High Speed
60UHPOA	0KW	.60	.60	.60	.60	.60	.60
60UHPOA	9KW 1PH	.60	.60	.60	.60	.60	.60
60UHPOA	14KW 1PH	.60	.60	.60	.60	.60	.60
60UHPOA	18KW 1PH	.60	.60	.60	.60	.60	.60
60UHPOA	9KW 3PH	.60	.60	.60	.60	.60	.60
60UHPOA	18KW 3PH	.60	.60	.60	.60	.60	.60

TABLE 6  
OPTIONAL FIELD-INSTALLED ELECTRIC HEATER TABLE

Heater Package Model No.	Heater Package Volts/Phase	Heater Amps, KW and Capacity @240 Volts			Heater Amps, KW and Capacity @208 Volts			(3) Minimum Circuit Ampacity	(3) Max. Fuse Size	(3) Maximum Circuit Breaker	(4) Field Wire Size
		AMPS	KW	BTU	AMPS	KW	BTU				
None								15	15	HACR Type 15	14
ERSBA-A09N,C	240/208-1	37.5	9	30690	32.5	6.75	23018	54	60	HACR Type 60	6
ERSBA-A14N,C	240/208-1	56.3	13.5	46035	48.7	10.13	34543	77	80	80	3
ERSBA-A18N,C	240/208-1	75	18	61380	64.9	13.5	46035	100	100	100	1
ERSBA-B09N	240/208-3	21.7	9	30690	18.7	6.75	23018	34	35	HACR Type 35	8
ERSBA-B18N	240/208-3	43.3	18	61380	37.5	13.5	46035	60	60	HACR Type 60	4

(3) Includes blower motor.

(4) Suggested size based on use of 60 degree C wiring material for ampacities less than 100A.

NOTE: 9kw is the maximum electric heat approved for 50HZ applications.

INDOOR BLOWER COIL PERFORMANCE (DRY COIL) (3)

TABLE 7

Model	KW	Speed	Position	In H2O (1) (2)									Position	In H2O (2)								
				.00	.10	.20	.30	.40	.50	.60	.70	.80		.00	.10	.20	.30	.40	.50	.60	.70	.80
BC48B	0	Hi	Upflow/	1930	1850	1760	1690	1605	1520	1430	1305	1195	Horizontal	1872	1818	1770	1710	1640	1560	1480	1365	1265
BC48B	0	Low	Counterflow	1840	1780	1700	1640	1555	1480	1375	1255	1145	Horizontal	1775	1739	1690	1635	1570	1500	1375	1305	1195
BC48B	9	Hi	Upflow/	1900	1820	1730	1660	1575	1490	1400	1290	1180	Horizontal	1842	1788	1740	1680	1610	1530	1450	1350	1250
BC48B	9	Low	Counterflow	1810	1750	1670	1610	1525	1450	1360	1290	1130	Horizontal	1745	1709	1660	1605	1540	1470	1345	1290	1180
BC48B	14 (4)	Hi	Upflow/	1885	1805	1715	1645	1560	1475	1385	1275	1165	Horizontal	1827	1773	1725	1665	1595	1515	1435	1335	1235
BC48B	14 (4)	Low	Counterflow	1795	1735	1655	1595	1510	1435	1345	1225	1115	Horizontal	1730	1694	1645	1590	1525	1455	1330	1275	1165
BC48B	18 (4)	Hi	Upflow/	1870	1790	1700	1630	1545	1460	1370	1260	1150	Horizontal	1812	1758	1710	1650	1580	1500	1420	1320	1220
BC48B	18 (4)	Low	Counterflow	1780	1720	1640	1580	1495	1420	1300	1210	1100	Horizontal	1715	1679	1630	1575	1510	1440	1315	1260	1150

INDOOR BLOWER COIL PERFORMANCE (DRY COIL) (3)

TABLE 8

Model	KW	Speed	Position	In H2O (1) (2)									Position	In H2O (2)								
				.00	.10	.20	.30	.40	.50	.60	.70	.80		.00	.10	.20	.30	.40	.50	.60	.70	.80
BC60B	0	Hi	Upflow/	2100	2030	1960	1880	1790	1700	1605	1485	1365	Horizontal	2100	2030	1960	1900	1800	1720	1630	1520	1395
BC60B	0	Low	Counterflow	1960	1900	1835	1773	1710	1620	1530	1405	1295	Horizontal	1940	1885	1830	1760	1710	1630	1535	1425	1305
BC60B	9	Hi	Upflow/	2070	2000	1930	1815	1760	1670	1575	1470	1350	Horizontal	2070	2000	1930	1870	1770	1690	1600	1505	1380
BC60B	9	Low	Counterflow	1930	1870	1805	1743	1680	1590	1500	1390	1280	Horizontal	1910	1855	1800	1730	1680	1600	1505	1410	1290
BC60B	14 (4)	Hi	Upflow/	2055	1985	1915	1835	1745	1655	1560	1455	1335	Horizontal	2055	1985	1915	1855	1755	1675	1585	1490	1365
BC60B	14 (4)	Low	Counterflow	1915	1855	1790	1728	1665	1575	1485	1375	1265	Horizontal	1895	1840	1785	1715	1665	1585	1490	1395	1290
BC60B	18 (4)	Hi	Upflow/	2040	1970	1900	1820	1730	1640	1545	1440	1320	Horizontal	2040	1970	1900	1840	1740	1660	1570	1475	1350
BC60B	18 (4)	Low	Counterflow	1900	1840	1775	1713	1650	1560	1470	1360	1350	Horizontal	1880	1825	1770	1700	1650	1570	1475	1380	1260

- NOTE: (1) Values shown are standard for both bottom and side return air opening in upflow position only.  
(2) Values shown are standard for bottom return air opening, side return air opening not applicable for counterflow or horizontal.  
(3) Values shown are for 230V/60HZ operation. For 208V operation reduce air flow by 130 CFM. For 50HZ application reduce CFM's by 17%.  
(4) Not approved for 50HZ application.



## I. APPLICATION AND LOCATION

### GENERAL

Units are shipped completely assembled and internally wired, requiring only duct connections, thermostat wiring and external 208-240 volt AC power supply.

The BC48B and BC60B blower coil units, with various KW electric heat options are suitable for use with the following air conditioner and heat pump outdoor sections. It can be used both as an air conditioning system with electric heat and as a heat pump with electric heat. Refer to sections titled, "AIR CONDITIONING WITH ELECTRIC HEAT and HEAT PUMP WITH ELECTRIC HEAT" for complete information.

TABLE 9  
APPROVED COMBINATIONS

Air Conditioning		Heat Pump	
<u>Outdoor Section</u>	<u>Indoor Section</u>	<u>Outdoor Section</u>	<u>Indoor Section</u>
		42UHPQA	BC48B
		48UHPQA	BC48B
		60UHPQA	BC60B

### UNPACKING

Upon receipt of equipment, carton should be checked for external signs of damage. If damage is found, request for inspection by carrier's agent should be made in writing immediately.

### APPLICATION

Size of unit for a proposed installation should be based on heat loss calculation made according to methods of Air Conditioning Contractors of America. The air duct should be installed in accordance with the Standards of the National Fire Protection Association for the Installation of Air Conditioning and Ventilating Systems of Other Than Residence Type, NEPA No. 90A, and Residence Type Warm Air Heating and Air Conditioning System, NEPA No. 90B. Where local regulations are at a variance with instructions, installer should adhere to local codes.

### DUCTWORK

Design the ductwork according to methods given by the Air Conditioning Contractors of America. When duct runs through unheated spaces, it should be insulated with a minimum of two inches of insulation. Use insulation with a vapor barrier on the outside of the insulation. Flexible joints should be used to connect the ductwork to the equipment in order to keep the noise transmission to a minimum.

## LOCATION AND CLEARANCES

All access to the equipment is from one side, and at least 24 inches should be provided from this side for service access.

Unit casing is suitable for 0 inch clearance. The first four (4) feet of ductwork attached to the outlet (supply air) connections of the unit are to have a minimum of one inch clearance, with 0 inch clearance for any remaining ductwork.

FIGURE 2

A CFB45A combustible floor base is required for downflow installations to assure a 1" clearance from combustible materials to the outlet plenum (duct).

A 21 x 23 opening is required in the floor (mounting surface). See illustrations.

The CFB45A combustible floor base must be ordered separately. It is not included as part of the basic unit.

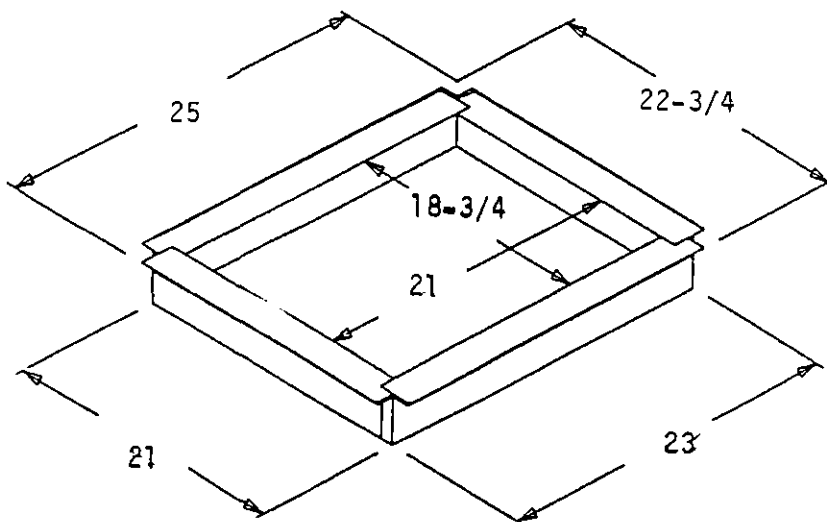

\*\*\*\*\*

**WARNING:** Failure to provide the one inch clearance for the first four feet between the supply duct and a combustible surface can result in fire.

\*\*\*\*\*

## MOUNTING POSITIONS

The blower coil can be installed in three positions with respect to airflow direction: Upflow, horizontal and downflow (see Figure 1). The general intent of these mounting positions is shown on the cover page of this installation manual. Capacity and efficiency ratings are certified in the vertical installation position. Capacity may be reduced slightly for other installation positions.

The unit is shipped with the coil installed for upflow position. It is secured in place by four screws, two on the top left support angles and two on the top right support angles. To convert to counterflow position, remove front access panel, remove the four screws securing coil pan assembly and remove coil.

Place cabinet in desired mounting position, and reinstall coil as shown on cover page. Make sure the coil is installed as shown with respect to blower.

**IMPORTANT:** The unit as received has coil installed for upflow position only. It must be rotated 180 degrees for downflow positions. See note under "Condensate Drain."

To convert to horizontal position, a field installed horizontal drain pan DPH-5BC is required. Instructions for installing the DPH-5BC are included with the drain pan.

## EXPANSION DEVICE

The flow control assembly has an orifice which provides the function of the expansion device as well as distributes the refrigerant equally to all evaporator circuits. It features a "take apart" brass body which houses the removable orifice which meters the proper amount of refrigerant flow and serves as the expansion device. This orifice can be removed and replaced.

There is an orifice shipped installed with the flow control in each coil. Refer to outdoor unit installation instructions to find if the orifice shipped installed is matched to the outdoor unit. Example: Outdoor unit 36UHPQA with BC60B is a matched combination. For other combinations of indoor coil to outdoor unit application, the orifice in the flow control device **MUST** be changed to the size shown in the chart in the outdoor unit installation instructions. An additional proper sized orifice to be used with each outdoor unit is shipped packaged in the envelope with the installation instructions, with each outdoor unit. The installer should mark the size of the orifice installed on the rating plate of the indoor coil. The diameter of the orifice is stamped on the side of the orifice and on the plastic bag. Example: 063 indicates the orifice is .063" inside diameter.

**CAUTION:** Be sure there is no dirt introduced into the flow control--orifice assembly. Be sure and install the orifice with the bullet nose pointing in the proper direction as shown in Figure 3. Failure to do so will result in improper operation.

**NOTE:** If the orifice does not have to be changed, skip the instructions outlined further in Step 1 and proceed to Step 7 as applicable.

FIGURE 3  
FLOW CONTROL FIELD ASSEMBLY PROCEDURES  
PRECHARGE COUPLING LINE SET

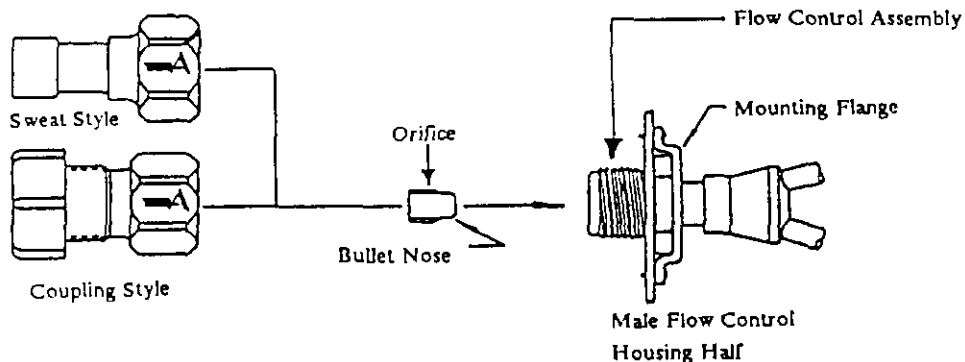

**NOTE:** DO NOT CONNECT LINE SETS! If orifice needs to be changed, change out orifice first.

**STEP 1** Remove charge/pressure from indoor unit (if necessary--coupling style).

**STEP 2** Disassemble Flow Control Assembly by turning body hex.

**STEP 3** If existing orifice has not dropped out of the body when disassembled, remove by using a pin or paper clip. Discard this original orifice.

**STEP 4** Insert properly sized orifice fully into the flow control body with rounded "bullet" nose towards the unit as shown. Insure the orifice stays inserted in body before connecting mating half. See chart in the outdoor unit installation instructions for proper size.

**STEP 5** Thread assembly halves together by hand to insure proper mating of threads and tighten until bodies "bottom" or a definite resistance is felt.

- STEP 6** Using a marker pen or ink pen, mark a line lengthwise from the union nut to the bulkhead. Then tighten an additional 1/6 turn (or 1 hex flat). The misalignment of the line will show the amount the assembly has been tightened. This final 1/6 turn is necessary to insure the formation of the leakproof joint.
- STEP 7** Complete piping and installation of unit per installation instructions. See Figure 4 for detailed assembly instructions.

#### CAUTION WHEN USING 5780 SERIES COUPLINGS

If coupling is every disconnected, the Flow Control Assembly connection may also be loosened. If this should occur, care must be taken to avoid loss of the orifice. If loosened, repeat Step 5 above to insure the reformation of leakproof joint.

FIGURE 4  
FLOW CONTROL ASSEMBLY  
FIELD ORIFICE REPLACEMENT INSTRUCTIONS

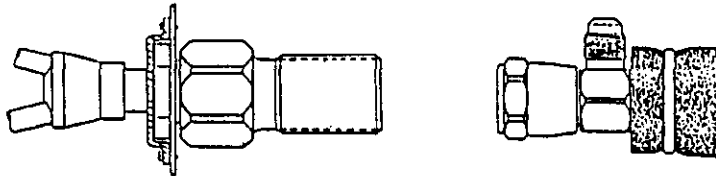

- STEP 8** Route the suction and liquid line between the indoor and outdoor unit. **CAUTION:** Do NOT connect the tubing to the outdoor unit yet.
- STEP 9** Remove protector caps and plugs.
- STEP 10** If necessary, carefully wipe coupling seats and threaded surfaces with a clean cloth to prevent the inclusion of dirt or any foreign material in the system.
- STEP 11** LUBRICATE male half diaphragm and synthetic rubber seal with refrigerant oil. Thread coupling halves together by hand to insure proper mating of threads. Use proper size wrenches (on line set coupling body hex and on union nut) and tighten until coupling bodies "bottom" or a definite resistance is felt.
- STEP 12** Using a marker or ink pen, mark a line lengthwise from the coupling union nut to the bulkhead. Then tighten an additional 1/4 turn; the misalignment of the line will show the amount the coupling has been tightened. This final 1/4 turn is necessary to insure the formation of leakproof joint. If a torque wrench is used, torque values recommends 10 to 12 foot pounds.
- STEP 13** Evacuate the lines and indoor unit before connecting to the outdoor unit. Refer to the installation instructions packed with the outdoor unit for details on setting the proper refrigerant charge.

**NOTE:** The lines and indoor coil do not have to be evacuated if they were not opened to the atmosphere to change the orifice.

## CONDENSATE DRAIN

Determine where the drain line will run. This drain line contains cold water and must be insulated to avoid drops of water from dropping on ceiling, etc. A trap must be installed in the primary drain line below the bottom of the drain pan. With a trap installed on a unit located in an unconditioned area, water in the trap may freeze. It is recommended that the trap material be of a type that will allow for expansion of water when it freezes.

For horizontal installations with auxiliary drain pan, a separate drain line should be run from the auxiliary drain pan and terminated where the homeowner can see it. Be certain to show the homeowner the location of the drain line and to explain its purpose. In the event of overflow of primary drain, water will collect in auxiliary pan and run out through the auxiliary drain line.

It is not recommended that any condensate drain lines be connected to sewer main. Drain lines must be installed in accordance with local codes.

When installed horizontal in an attic installation, a platform should be made for the unit to sit on. This platform can be made from 3/4 inch plywood or boards. An auxiliary drain pan should always be used when equipment is installed over a finished living area, to provide protection from water damage in case of plugging of the primary drain line from the unit condensate collection pan.

Secure 4 pieces of cork or live rubber, 4" x 4", of sufficient thickness to allow primary drain to clear edge of auxiliary drain pan, under each corner of the unit.

**NOTE:** There are two 3/8" copper tubes brazed through the coil drain pan approximately 2 inches from the 3/4 inch main drain pipe coupling. These are overflow drains to control the point at which water would exit the drain pan in the event the primary drain becomes plugged. When ever the coil assembly is removed and reinstalled, make sure the 3/8" drain overflow tubes extend slightly beyond the coil door when in place.

## II. WIRING

### THERMOSTAT LOW-VOLTAGE WIRING

A 24V terminal block is mounted on the inside of the unit. There is also a 24V terminal block located in the outdoor section of remote heat pumps and two tagged 24V wires in the outdoor section of remote air conditioners. Wire sizing is determined from the table below for 24V control circuit wiring.

TABLE 10

<u>Transformer VA</u>	<u>FLA @ 240V</u>	<u>Maximum Distance in Feet (1)</u>
55	2.3	20 gauge - 45 18 gauge - 60 16 gauge - 100 14 gauge - 160 12 gauge - 250

(1) For split systems, this is the maximum distance between the indoor section and outdoor section, and between the indoor section and thermostat each could be up to 90 feet for 18 gauge and 65 feet for 20 gauge on 40VA transformer.

Specific control circuit wiring diagrams for the various applications are referenced in the sections titled "AIR CONDITIONING WITH ELECTRIC HEAT and HEAT PUMP WITH ELECTRIC HEAT." These diagrams detail the recommended controls and wiring to allow the best possible operation of the different types of systems with respect to energy conservation while still maintaining close comfort levels for the occupant.

## UNIT OPERATION

The controls in the BC48B and BC60B provide for manual/auto fan control in addition to the staging of the installed electric heat. Staging is accomplished in basic 9KW increments, that is, each two (2) heating elements are controlled by one heat relay.

TABLE 11  
HEATER ELEMENT STAGING

Heater KW	Stages
5, 9	1
14, 18	2

Heater stage designations are as follows on the 24V terminal strip:

W2	1st stage
W3	2nd stage
DH	3rd stage

## AIR CONDITIONING WITH ELECTRIC HEAT

Typical situations would be to utilize a 1-stage cool, 1-stage heat wall thermostat for 5 and 9KW applications, and a 1-stage cool/2-stage heat thermostat for 14 and 18KW applications. Listed below are the appropriate control circuit connection diagrams based upon KW rating and also the number of field installed outdoor thermostats required for each application.

TABLE 12

KW Rating	Connection Diagram	Quantity Outdoor Thermostats
0	4091-300	0
5,9	4091-301	0
14,18	4091-303	0

## HEAT PUMP WITH ELECTRIC HEAT

The system and its safety controls are designed in such a manner that the heat pump and up to 18KW of the resistance strip heaters can operate at the same time, being brought on in stages.

Listed below are the appropriate control circuit connection diagrams based on KW rating, and also the number of field installed outdoor thermostats recommended for each application.

TABLE 13

KW Rating	Connection Diagram	Quantity Outdoor Thermostats
0	4091-400 or 4091-805	0
5,9	4091-401 or 4091-806	1
14,18	4091-403 or 4091-807	1

In geographical areas where compressor cut-off would not be required because winter temperatures below 10 degrees F are never experienced, disregard the compressor cut-off wiring shown on the control circuit diagram.

## HOW TO SET AN ADJUSTABLE ANTICIPATOR

The primary purpose of the adjustable anticipator thermostat is to provide a single thermostat to match almost any type of primary control in the field today.

Figure 5

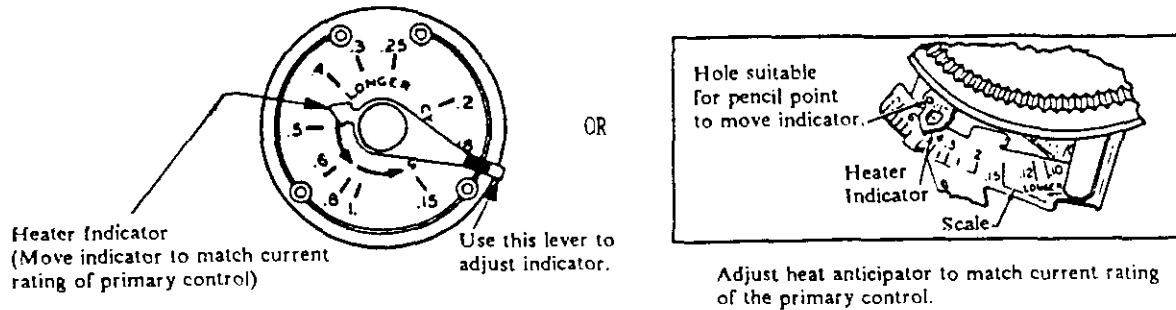

The adjustable heat anticipator has a slide wire adjustment with the pointer scale marked in tenths of an ampere. This is used to set the anticipator to agree with the control amp draw of the control system in use.

If the primary control nameplate has no rating or if further adjustment is necessary, use the following procedure to determine the current draw of each stage.

The current draw of each heating stage must be measured with the thermostat removed and the power on.

1. Connect an AC ammeter of appropriate range between the heating terminals of the subbase.

Stage 1 -- between W1 and RH or R

Stage 2 -- between W2 and RH or R

2. Move the system switch to HEAT or AUTO.
3. After one minute, read the ammeter and record the reading.
4. After mounting the thermostat, set the adjustable heat anticipator(s) to match the respective reading(s) measured in Step 3.

If you want to change the cycle of the heating system, you can make a simple adjustment on the anticipator to do this.

Additional adjustment, if necessary, may be made as follows:

Heater cycles too short--set adjustable heater to a slightly higher dial setting (1/2 division).

Heater cycles too long--set adjustable heater to a slightly lower dial setting (1/2 division).

Occasionally you may find a system where longer or shorter cycles of the primary control are desirable. If the primary control draws .45 amps and you want a longer cycle, set the anticipator to .5 or .6 amps. This puts less resistance in the circuit. With less resistance, but the same current (from the primary control), you will generate less "false" heat and get a longer cycle of the primary control.

If a setting of .45 amps on the adjustable anticipator gives a cycle that is longer than desired, reset the indicator to .3 or .25 amps. This will put more resistance in the circuit and thus generate more "false" heat for shorter cycles.

## ADDITIONAL INFORMATION FOR ELECTRIC HEAT OR HEAT PUMP APPLICATIONS

Adjust heat anticipator to match current rating of heating relay for W1 (and W2 if 2 stage). Move indicator on the scale to correspond with this current rating.

If the current rating is not given, proceed as follows:

1. Wrap exactly 10 loops of thermostat wire (W1) around the prongs of an Amprobe.
2. Let the heating system operate for one minute before reading the W1 or W2 current draw.
3. Divide the reading obtained in Step 2 by 10.
4. Use the value calculated in Step 3 to set the heat.
5. Repeat the procedure for (W2) if 2 stage heat anticipator.

**NOTE:** Cooling anticipators on all thermostats are fixed and do not require setting.

FIGURE 6

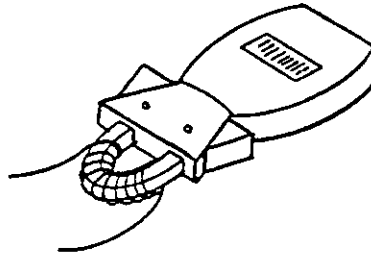

Example:  $\frac{6.0 \text{ Amp}}{10 \text{ loops}} = .6A$

## III. SERVICE

### TWO SPEED BLOWER MOTOR

The BC488 and NBC608 both have a two speed, 1/2 hp blower motor.

Motor lead wire identification is as follows:

Common	Yellow
High	Black
Low	Red
Capacitor	Brown

Both models are shipped wired on high speed. The unused red (low speed) lead wire is taped off. If low speed operation is desired, remove and tape black wire from terminal com. on blower relay and connect red wire to terminal com. Refer to wiring diagrams for electrical circuitry and to airflow charts for capabilities and limitations on blower speeds, static pressures and air delivery versus installed KW heaters.



## **FILTER**

These units come equipped with a 20" x 25" x 1" thick disposable fiberglass filter and must not be operated without a filter in place. Filter access is gained by removing an angle piece located at the bottom of the main unit cabinet (as viewed in upflow position).

The filter should be replaced periodically throughout the year, as these are year-round heat-cool systems. Special attention should be given to filter cleanliness on any new installation, as airborne dust and debris from recent construction can easily plug a filter in a matter of days.

Dirty filters are the most prevalent and most easily corrected problem to be encountered in any forced air heating and/or cooling system.

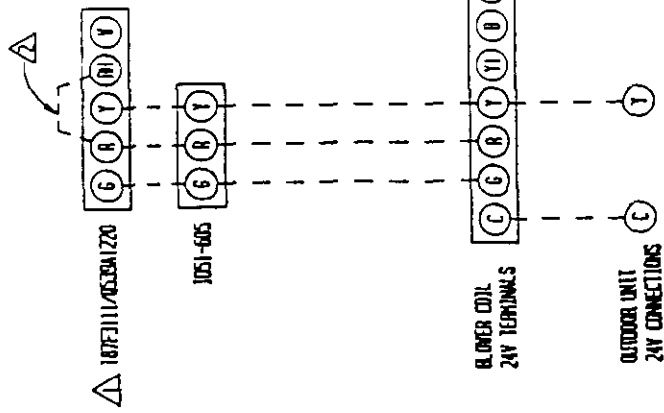

△ SET ADJUST HEAT ANTICIPATOR (SEE BLOWER COIL INSTRUCTIONS).  
 △ INSIAL JUMPER R-04

FACTORY WIRING	FIELD WIRING
LOW VOLTAGE	---
HIGH VOLTAGE	---

AIR CONDITIONER V/OXY BLOWER COIL

4691-300

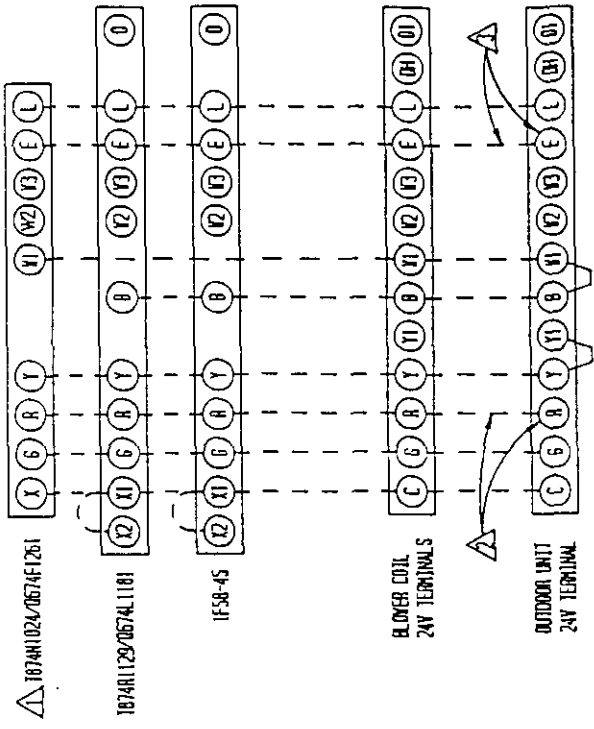

HEATPUMP V/OXY BLOWER COIL

△ SET ADJUST HEAT ANTICIPATOR (SEE BLOWER COIL INSTRUCTIONS).  
 △ 18-36RPO UNITS DO NOT HAVE (B) TERMINAL AND IT IS NOT REQUIRED TO RUN AN (E) WIRE TO THESE MODELS.  
 △ 42-60RPO UNITS DO NOT HAVE (E) TERMINAL AND IT IS NOT REQUIRED TO RUN AN (E) WIRE TO THESE MODELS.

FACTORY WIRING	FIELD WIRING
LOW VOLTAGE	---
HIGH VOLTAGE	---

4691-400A



▲ SET ADJUST HEAT ANTICIPATOR (SEE HEATER COIL INSTRUCTIONS).  
 ▲ INITIAL JUMPER W-111  
 ▲ AIR CONDITIONER V/14 TO 20XV HEATER COIL EXCEPT FOR B0310-A15 & B700A WELLS

4091-301

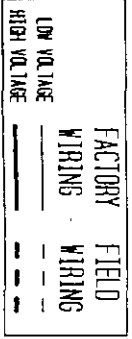
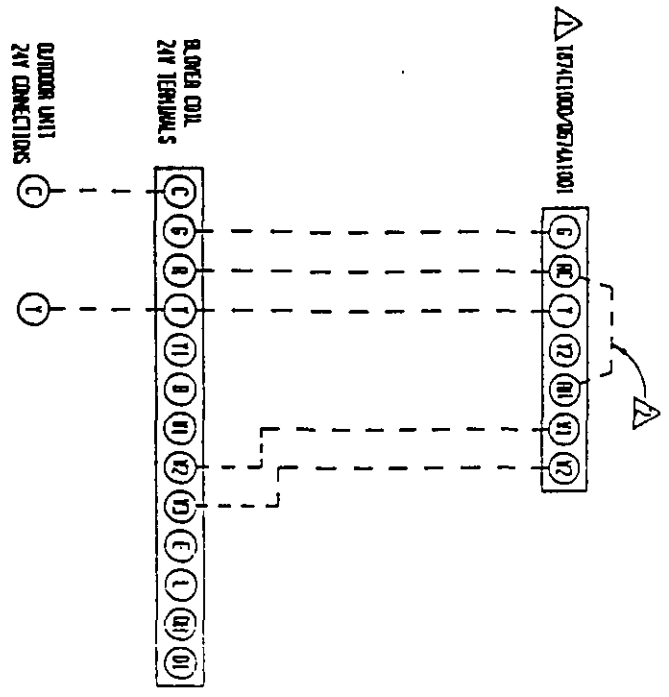

HEATING V/14 TO 20XV BLOWER COIL

▲ SET ADJUST HEAT ANTICIPATOR (SEE BLOWER COIL INSTRUCTIONS).  
 ▲ WHEN OUTDOOR THERMOSTAT (USED AS COMPRESSOR OFFER) IS INSTALLED, REMOVE JUMPER Y-11.  
 ▲ IF OUTDOOR THERMOSTAT IS USED TO SHAKE HEAT, REMOVE JUMPER W-011.  
 ▲ 18-3000 UNITS DO NOT HAVE ① TERMINAL, AND 11 IS NOT REQUIRED TO RUN AN ② WIRE TO THESE ADDRES.  
 ▲ FOR COMMERCE APPLICATIONS, REMOVE JUMPER Y-01 ON B1C39 & B1C59 MODELS ONLY.

4091-403 C

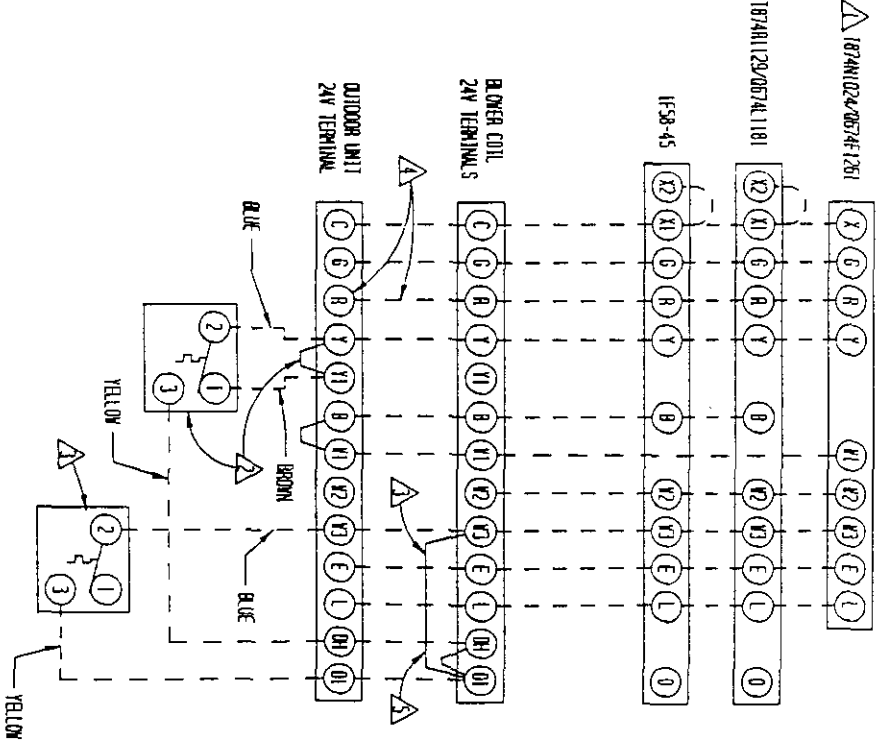

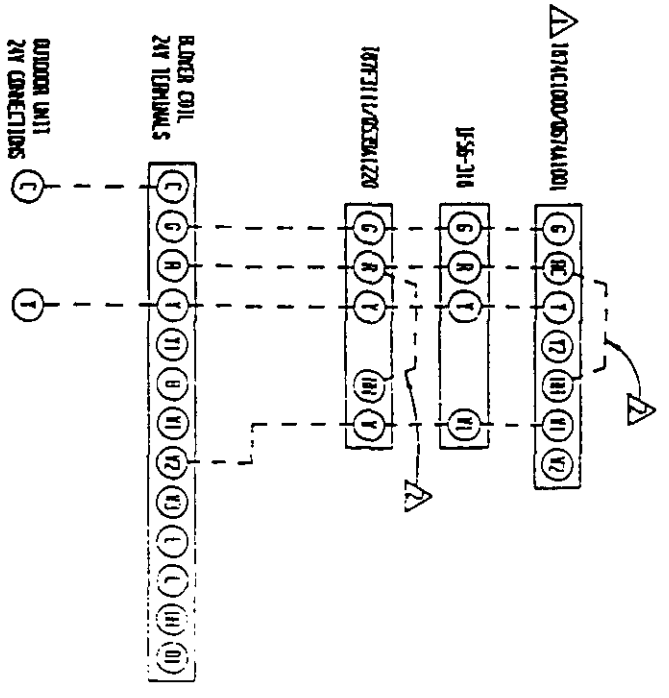

LOW VOLTAGE	FACTORY WIRING	FIELD WIRING
HIGH VOLTAGE	-----	- - - - -

⚠ SET ADJUST HEAT ANTICIPATION (SEE BLOWER COIL INSTRUCTIONS).

⚠ INSTALL THERM BE-81 ON R-81

AIR CONDITIONER VS TO LOW BLOWER COIL EXCEPT FOR BE-81-A10

4091-301

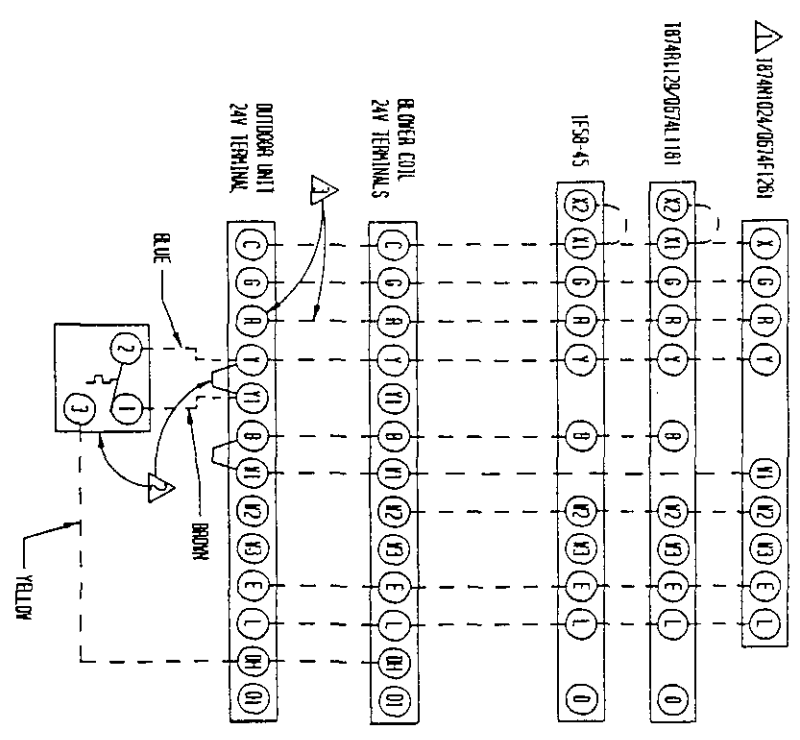

LOW VOLTAGE	FACTORY WIRING	FIELD WIRING
HIGH VOLTAGE	-----	- - - - -

⚠ SET ADJUST HEAT ANTICIPATION (SEE BLOWER COIL INSTRUCTIONS).

⚠ WHEN OUTDOOR THERMOSTAT (USED AS COMPRESSOR CUTOFF) IS INSTALLED, REMOVE THERM R-71.

⚠ 18-3000 UNITS DO NOT HAVE Ⓣ TERMINAL AND IT IS NOT REQUIRED TO RUN AN Ⓣ WIRE TO THESE MODELS.

4091-401 C

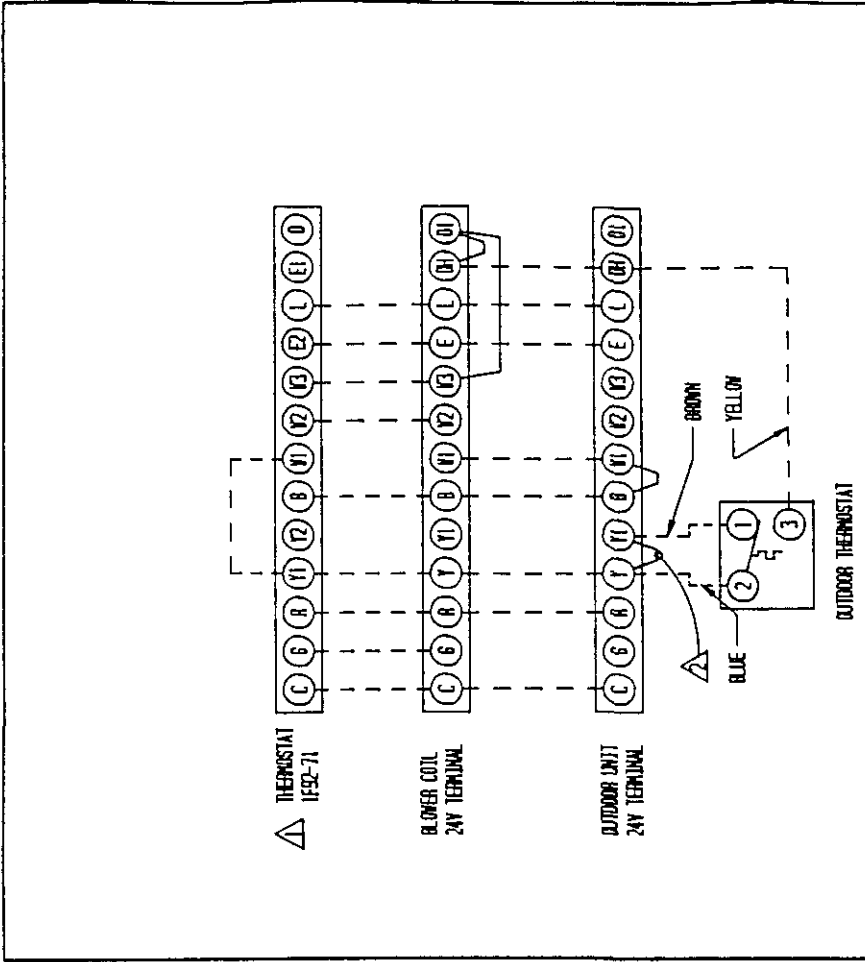

▲ THERMOSTAT IF92-71  
 ▲ IF OUTDOOR THERMOSTAT (USED AS COMPRESSOR OUTOFF) IS INSTALLED, REMOVE JUMPER Y-T1.

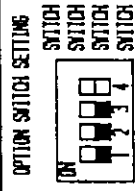

LOW VOLTAGE	FACTORY WIRING	FIELD WIRING
HIGH VOLTAGE	HEATPUMP V/S OR 90V BLOWER COIL	

4891-805 A

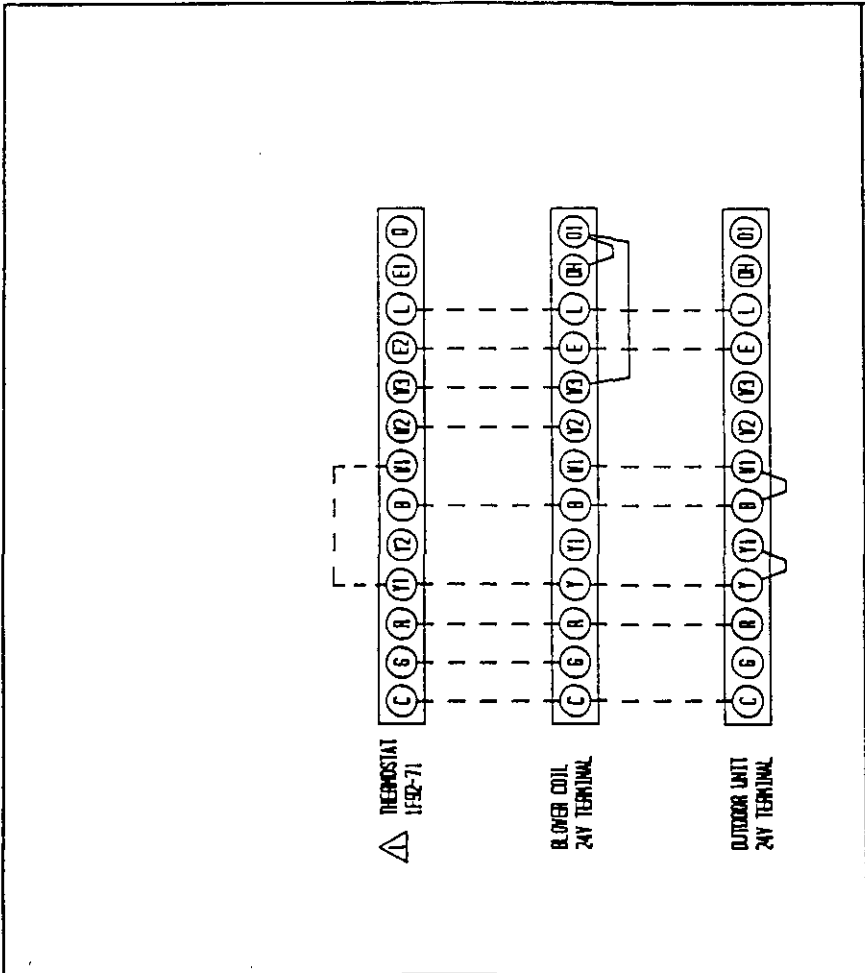

▲ THERMOSTAT IF92-71  
 ▲ OPTION SWITCH SETTINGS  
 SWITCH #1 'OFF'  
 SWITCH #2 'OFF'  
 SWITCH #3 'OFF'  
 SWITCH #4 SEE THERMOSTAT INSTALLATION INSTRUCTIONS



LOW VOLTAGE	FACTORY WIRING	FIELD WIRING
HIGH VOLTAGE	HEATPUMP V/S OR 90V BLOWER COIL	

4891-805 A

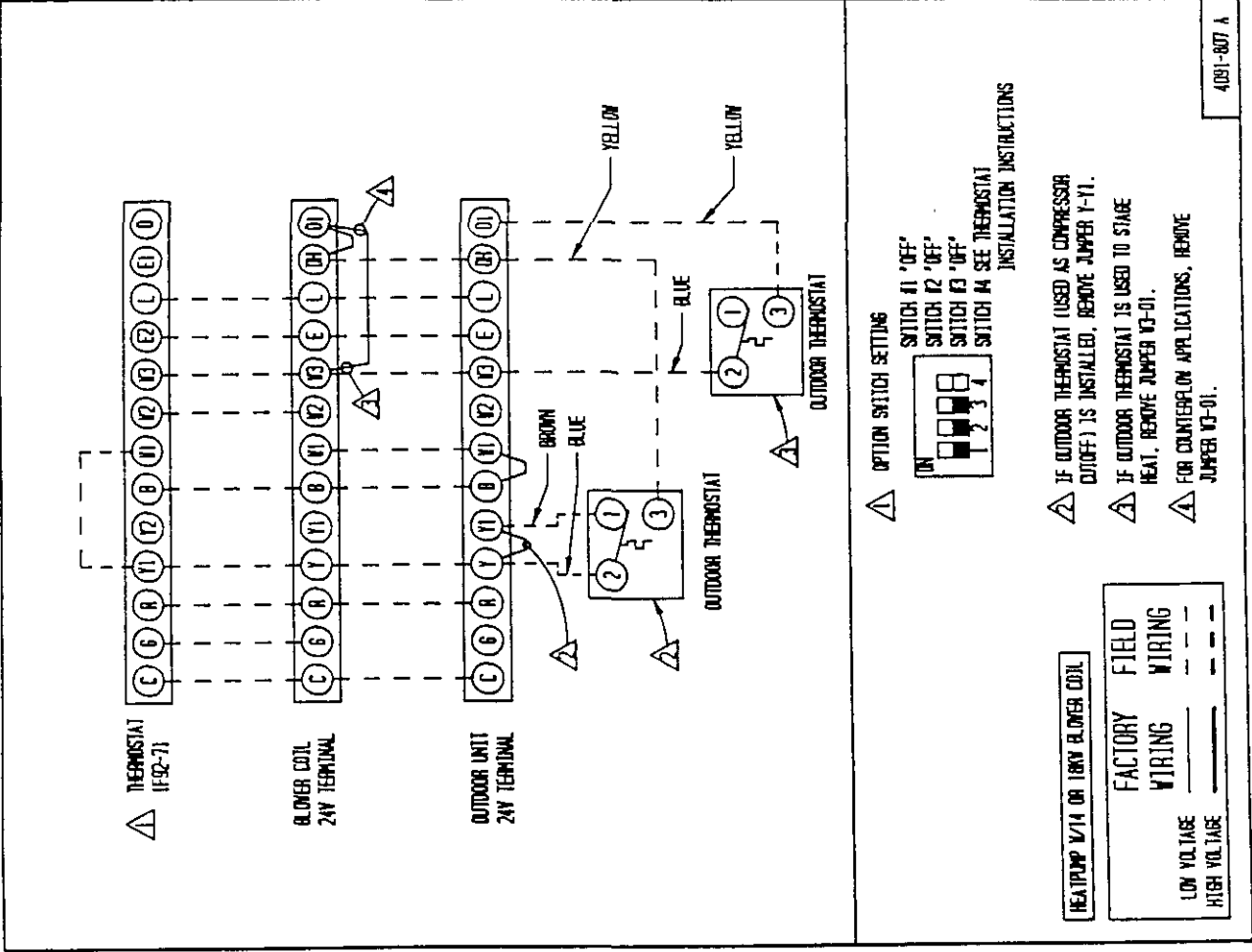

4091-807 A

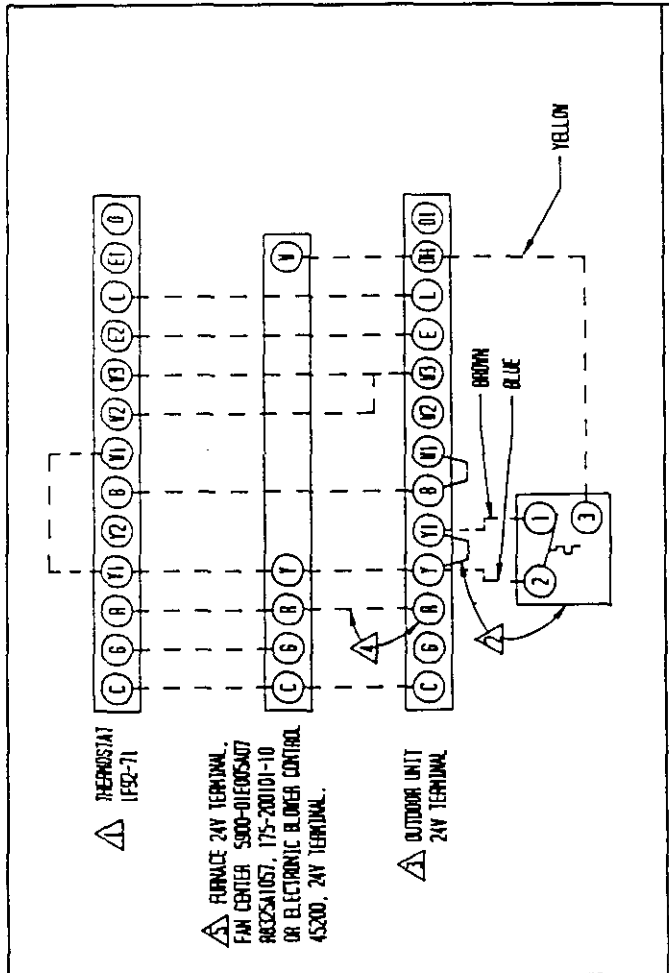

▲ THERMOSTAT (F2-7)

▲ FURNACE 24V TERMINAL, FAN CENTER 5900-01E065A07 OR ELECTRONIC BLOWER CONTROL 45200, 24V TERMINAL.

▲ OUTDOOR UNIT 24V TERMINAL

▲ OPTION SWITCH SETTING

ON SWITCH #1 'OFF' SWITCH #2 'OFF' SWITCH #3 'OFF' SWITCH #4 SEE THERMOSTAT INSTALLATION INSTRUCTIONS

- ▲ WHEN OUTDOOR THERMISTATE (USED AS CHANGEOVER THERMISTAT) IS INSTALLED, REMOVE JUMPER Y-Y1.
- ▲ IF IT DESIRED NOT TO ALLOW FURNACE TO CYCLE 'ON' DURING DEFROST, A 24V FACTORY WIRE RETURN (TERMINAL '3' OF DEFROST RELAY AND TERMINAL '4' ON EMERGENCY HEAT RELAY ON HPN MODELS OR TERMINAL ② OF HEATPUMP CONTROL AND TERMINAL ③ ON TERMINAL BOARD ON IHP MODELS) MUST BE REMOVED.
- ▲ HPN SERIES MODEL DO NOT HAVE ④ TERMINAL AND IT IS NOT REQUIRED TO RUN ④ WIRE TO THESE MODELS.
- ▲ IF THE FURNACE IS NOT INTERNALLY WIRED FOR AOD ON AIR CONDITIONING, A FAN CENTER WILL NEED TO BE ADDED.

HEAT PUMP W/GAS FURNACE

LOW VOLTAGE	FACTORY WIRING	FIELD WIRING
HIGH VOLTAGE	-----	-----

4091-808 A

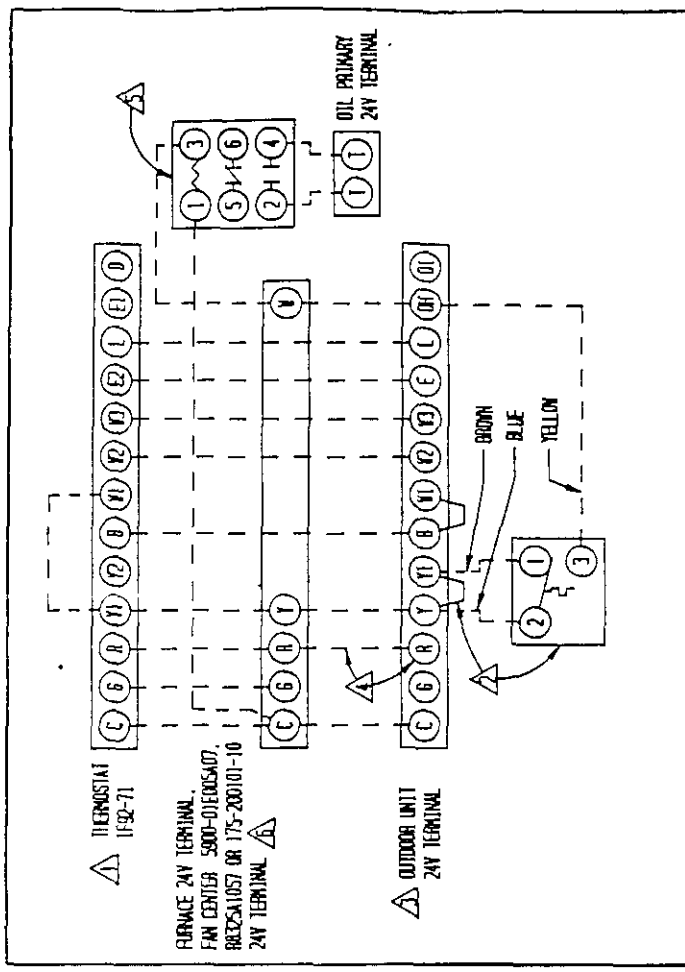

▲ THERMOSTAT (F2-7)

▲ FURNACE 24V TERMINAL, FAN CENTER 5900-01E065A07, RECESSA1057, 175-200101-10 24V TERMINAL.

▲ OUTDOOR UNIT 24V TERMINAL

▲ OPTION SWITCH SETTING

ON SWITCH #1 'OFF' SWITCH #2 'OFF' SWITCH #3 'OFF' SWITCH #4 SEE THERMOSTAT INSTALLATION INSTRUCTIONS

- ▲ WHEN OUTDOOR THERMISTATE (USED AS CHANGEOVER THERMISTAT) IS INSTALLED, REMOVE JUMPER Y-Y1.
- ▲ IF IT DESIRED NOT TO ALLOW FURNACE TO CYCLE 'ON' DURING DEFROST, A 24V FACTORY WIRE RETURN (TERMINAL '3' OF DEFROST RELAY AND TERMINAL '4' ON EMERGENCY HEAT RELAY ON HPN MODELS OR TERMINAL ② OF HEATPUMP CONTROL AND TERMINAL ③ ON TERMINAL BOARD ON IHP MODELS) MUST BE REMOVED.

HEAT PUMP VOIL FURNACE

LOW VOLTAGE	FACTORY WIRING	FIELD WIRING
HIGH VOLTAGE	-----	-----

4091-800 A

## WALL THERMOSTATS

The following wall thermostats and subbases should be used as indicated, depending on the application.

TABLE 14

AIR CONDITIONING THERMOSTATS	
Model No.	Description
T87F3111 Q539A1220	THERMOSTAT--1 stg. heat, adj. heater, Mercury SUBBASE --System Heat-Off-Cool Fan: On-Auto
I051-605	THERMOSTAT--1 stg. cool, System w/Off Sw. Snap Action Fan: Auto-On
IF56-318	THERMOSTAT--1 st. cool, 1 stg. heat, Adj. heater Mercury System: Heat-Off-Cool Fan: Auto-On
T874C1000 Q674A1001	THERMOSTAT--1 stg. cool, 2 stg. heat, Adj. heater, Mercury SUBBASE --System: Heat-Auto-Cool Fan: Auto-On
HEAT PUMP THERMOSTATS	
Model No.	Description
T874R1129 Q674L1181	THERMOSTAT--1 stg. cool, 2 stg. heat, 1st stage fixed, 2nd stg. adj. heat anticipators SUBBASE --System switch: Em. Heat-Heat-Off-Cool Fan switch: On-Auto SPECIAL FEATURE: Manual Changeover (Non-Cycling Rev. Valve) Em. heat light and System check light
T874N1024 Q674F1261	THERMOSTAT--1 stg. cool, 2 stg. heat, 1st stage fixed, 2nd stg. adj., heat anticipators SUBBASE --System switch: Off-Cool-Auto-Heat-Em.Ht. Fan switch: On-Auto SPECIAL FEATURE: Auto system changeover, Em. heat light and System check light
IF58-45	THERMOSTAT--1 stg. cool, 2 stg. heat, 1st stage fixed, 2nd stg. adj. heater System switch: Em. Heat-Heat-Off-Cool Fan Switch: On-Auto
IF92-1	THERMOSTAT--2 stg. cool, 3 stg. heat, electronic SUBBASE --Manual or automatic changeover, 2 set-up/set-back periods per day, 5 or 7 day programming



# CONNECTION DIAGRAM

DANGER: ELECTRICAL SHOCK HAZARD.  
DISCONNECT POWER BEFORE SERVICING.

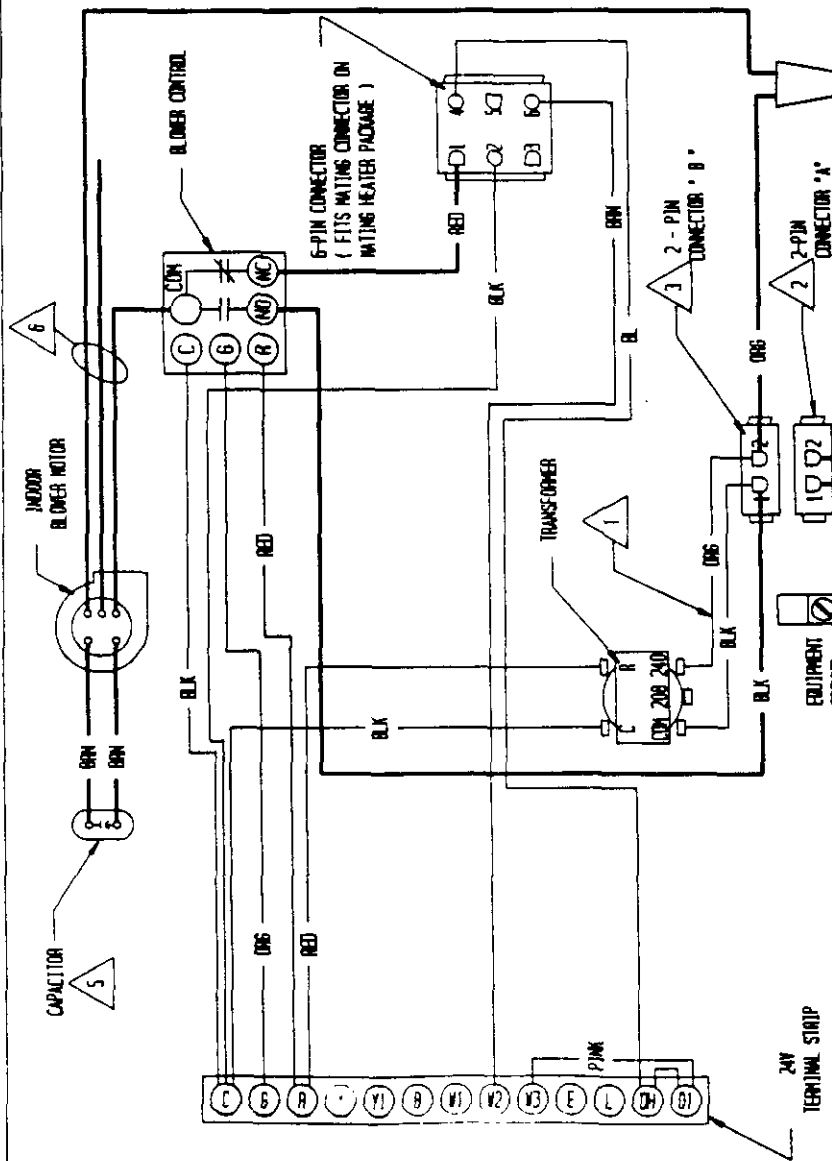

- 1 FOR 200V OPERATION MOVE THIS WIRE TO THE 200V TRANSFORMER TAP
- 2 2-PIN CONNECTOR 'A' USED FOR FIELD CONNECTION WHEN NO HEATER PACKAGE IS INSTALLED.
- 3 WHEN HEATER PACKAGE IS INSTALLED, CONNECTOR 'B' CONNECTS TO MATING CONNECTOR ON HEATER PACKAGE.
- 4 REFER TO INSTALLATION INSTRUCTIONS FOR CONTROL CIRCUIT WIRING

Low Voltage	FACTORY WIRING
High Voltage	FIELD WIRING

# LADDER DIAGRAM

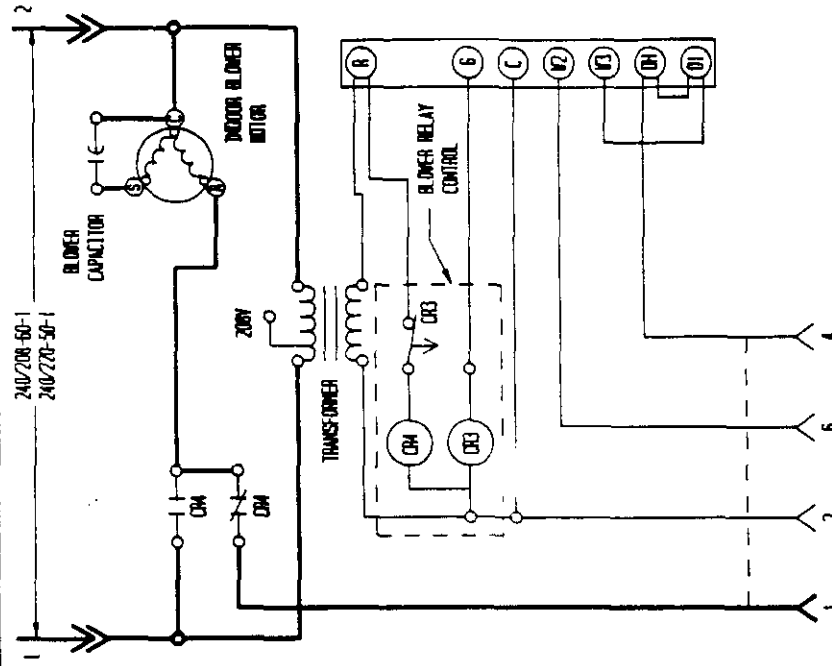

MODEL	CAPACITOR	WIRE COLOR	MOTOR SPEED
BC240	5/370	YELLOW	COMMON
BC35B		BLACK	HIGH
BC36B	7.5/440	BLUE	MEDIUM (BC240, BC300 ONLY)
BC400 (BC300)		RED	LOW

