

INSTALLATION INSTRUCTIONS

MODELS

EH5BA-A09N

EH5BA-A14N

EH5BA-A18N

EH5BA-B09N

EH5BA-B18N

EH5BA-A09C

EH5BA-A14C

EH5BA-A18C

OPTIONAL ELECTRIC HEAT PACKAGES FOR USE WITH MODEL

BC48B

BC60B

MANUAL 2100-180 REV.
SUPERSEDES REV.
FILE VOL. I, TAB 7

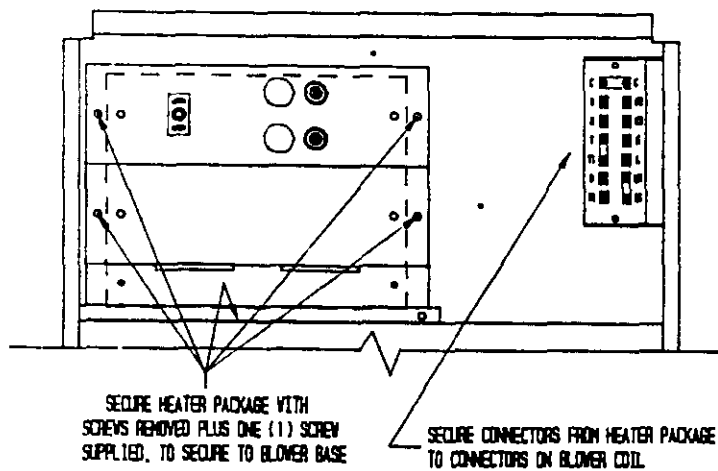
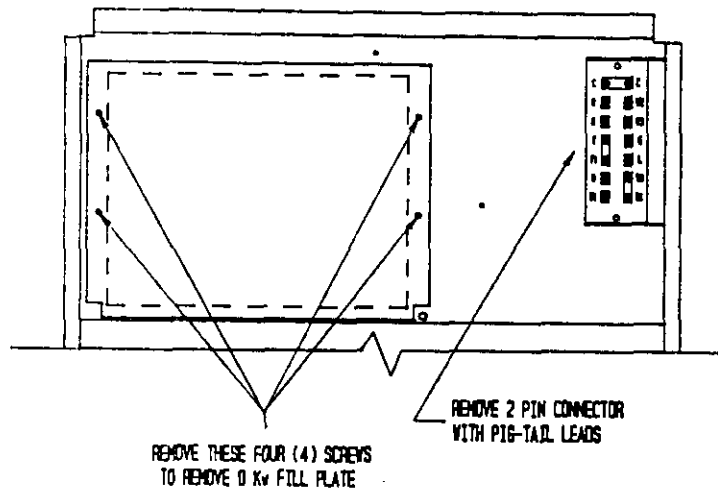

IMPORTANT

The equipment covered in this manual is to be installed by trained, experienced service and installation technicians.

SHIPPING DAMAGE

Upon receipt of equipment, the carton should be checked for external signs of shipping damage. If damage is found, the receiving party must contact the last carrier immediately, preferably in writing, requesting inspection by the carrier's agent.

UNPACKING THE HEAT PACKAGE

Remove the heat package from the shipping carton. The heat package must consist of the following:

1. Basic heater enclosure with controls.
2. Installation instructions and wiring diagram.

INSTALLATION

Disconnect all power supplies to the blower coil. Remove the blower service door located at the top of the unit. Remove the four screws used to secure the OKW fill plate to the control panel partition. (Figure 1)

NOTE: With installation heater packages that are equipped with circuit breakers, the control panel cover can not be used and must be removed.

WIRING

Remove the two pin plug in connector supplied for field wiring of blower coil when no heater package is installed. Field wiring will now be made at the heater package.

Slide heater package into blower coil and secure with the four screws that held OKW fill plate in place and one screw supplied with heater package.

Connection between the heater package and the blower coil is made by plugging in the plastic snap lock fittings into the mating fittings located in the control area.

Power supply wiring can now be made to the heater package which will supply power to the transformer and blower motor without a separate power supply.

Inspect all wiring for damage and secure any loose wiring. Apply the heater package wiring diagram supplied next to the blower coil wiring diagram in such a way as to not cover the circuit breaker knockouts.

NOTE: For heater packages with circuit breakers, remove the proper knockout(s) in the blower service door that will allow the circuit breakers to extend through the service door.

Replace the blower service door, energize the unit and check for proper system operation.

CONNECTION DIAGRAM

DANGER: ELECTRICAL SHOCK HAZARD.
DISCONNECT POWER BEFORE SERVICING.

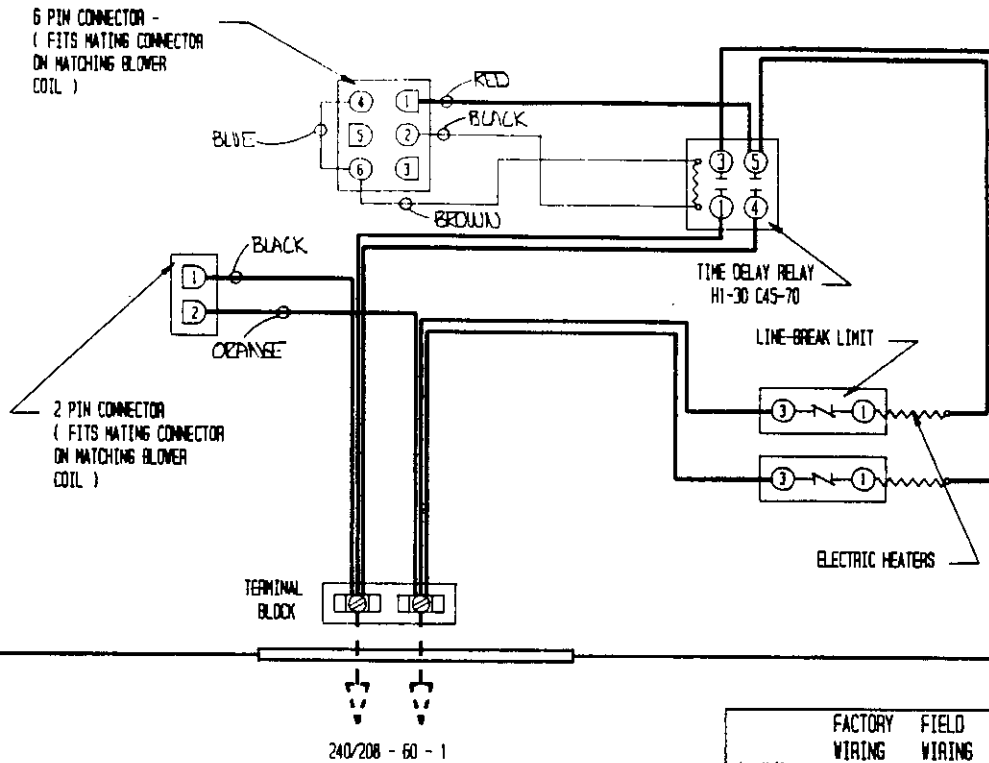

NOTE: REFER TO THE HEATER PACKAGE
INSTRUCTIONS FOR PROPER INSTALLATION

	FACTORY WIRING	FIELD WIRING
Low Voltage	—————	-----
High Voltage	—————	-----

USE COPPER OR
ALUMINUM WIRE

LADDER DIAGRAM

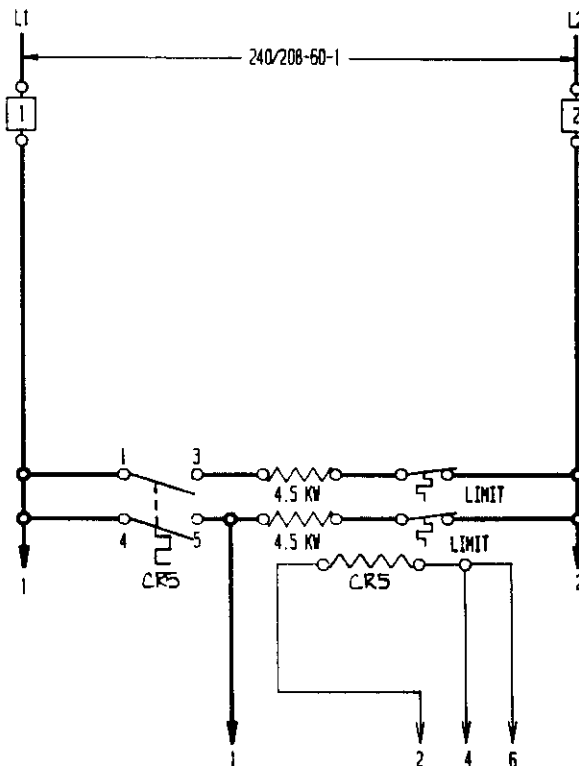

CONNECTION DIAGRAM

DANGER: ELECTRICAL SHOCK HAZARD.
DISCONNECT POWER BEFORE SERVICING.

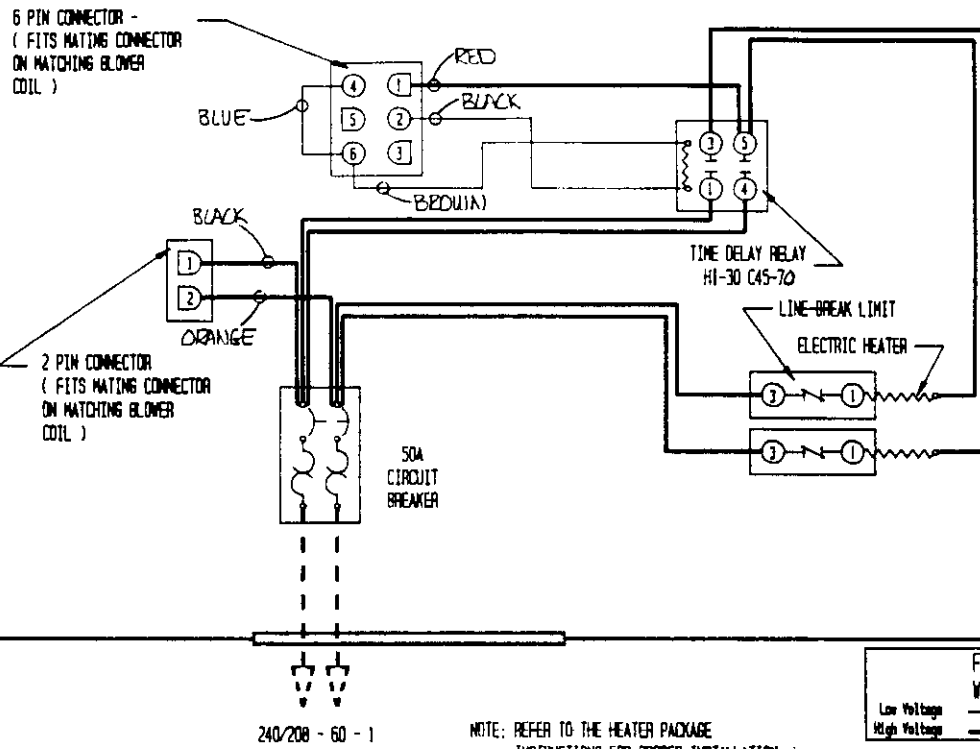

LADDER DIAGRAM

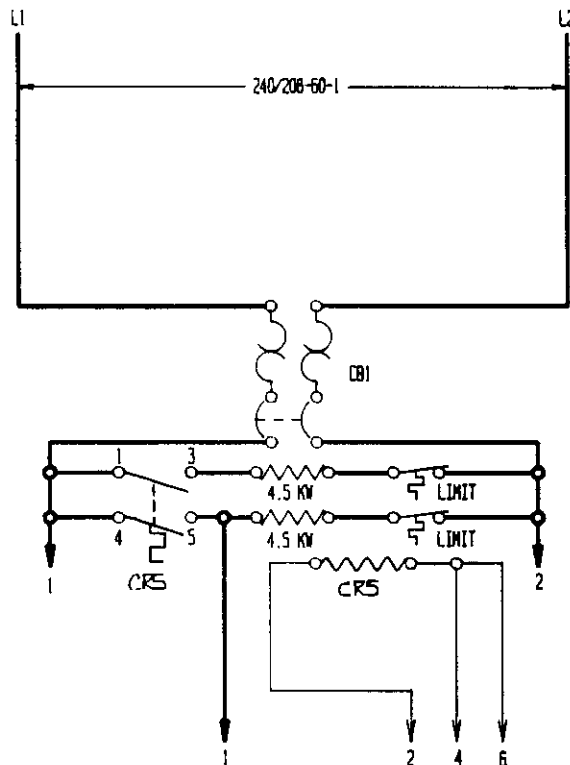

CONNECTION DIAGRAM

DANGER: ELECTRICAL SHOCK HAZARD.
DISCONNECT POWER BEFORE SERVICING.

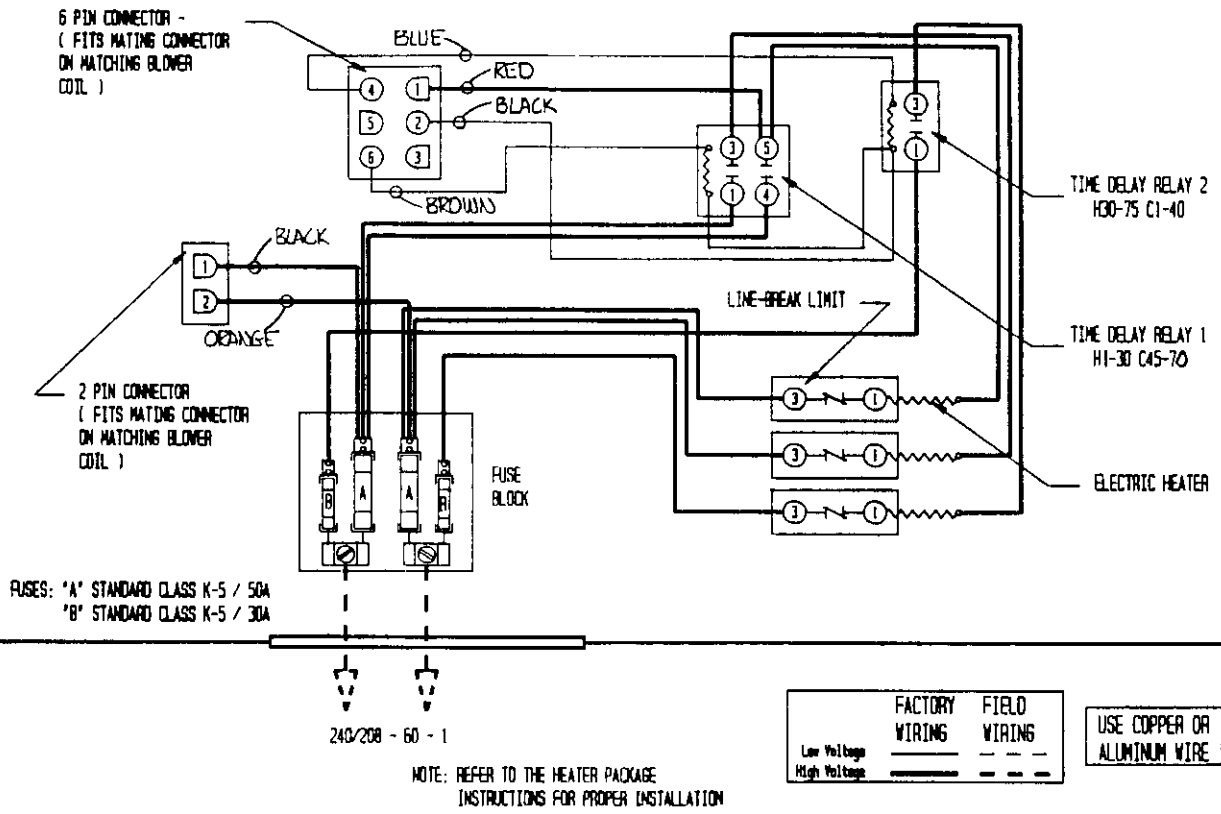

LADDER DIAGRAM

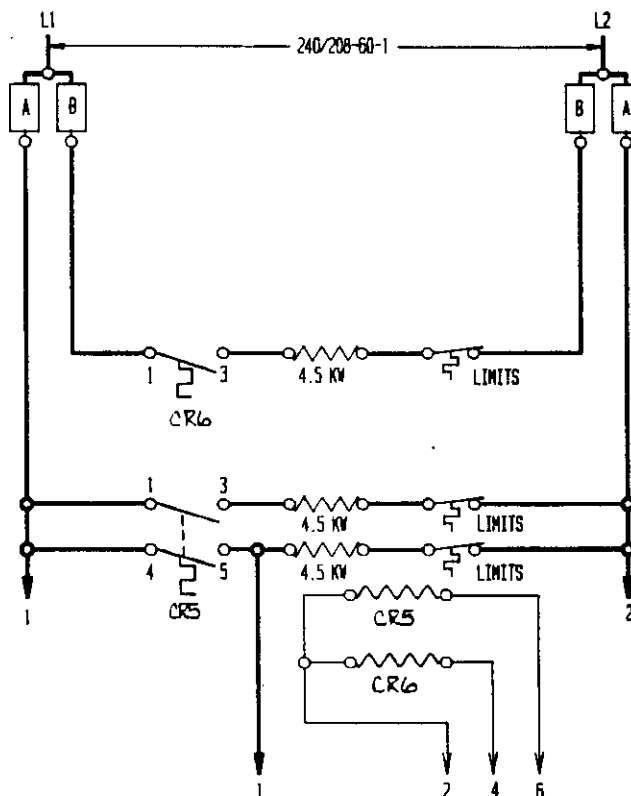

CONNECTION DIAGRAM

**WARNING: DANGER: ELECTRICAL SHOCK HAZARD.
DISCONNECT POWER BEFORE SERVICING.**

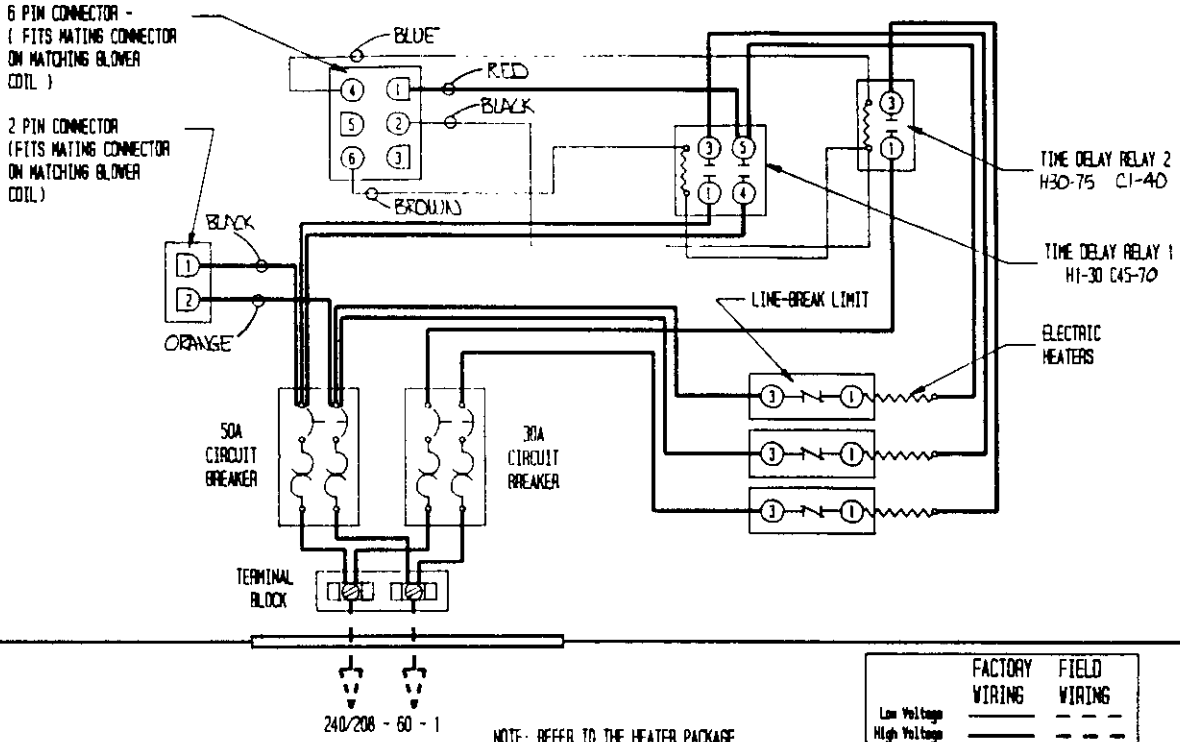

NOTE: REFER TO THE HEATER PACKAGE INSTRUCTIONS FOR PROPER INSTALLATION

	FACTORY WIRING	FIELD WIRING
Low Voltage	---	---
High Voltage	---	---

USE COPPER OR ALUMINUM WIRE

LADDER DIAGRAM

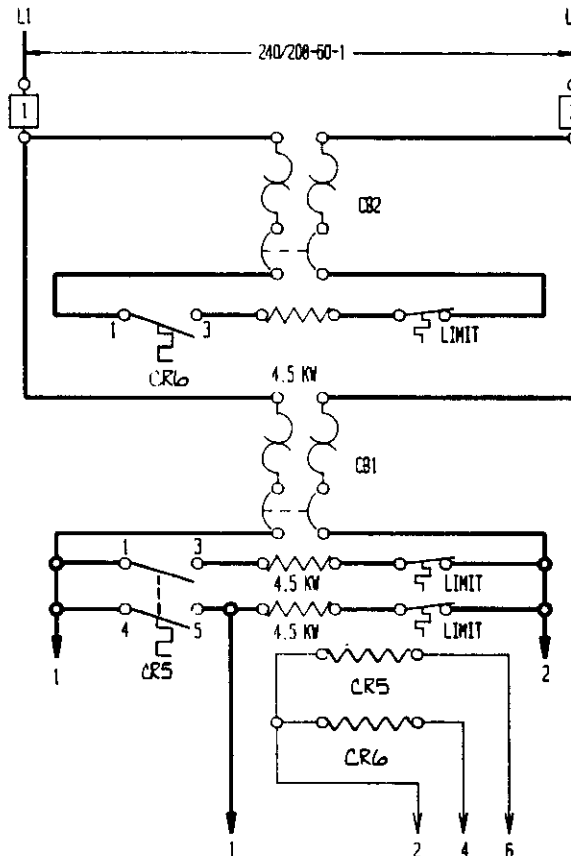

CONNECTION DIAGRAM

DANGER: ELECTRICAL SHOCK HAZARD.
DISCONNECT POWER BEFORE SERVICING.

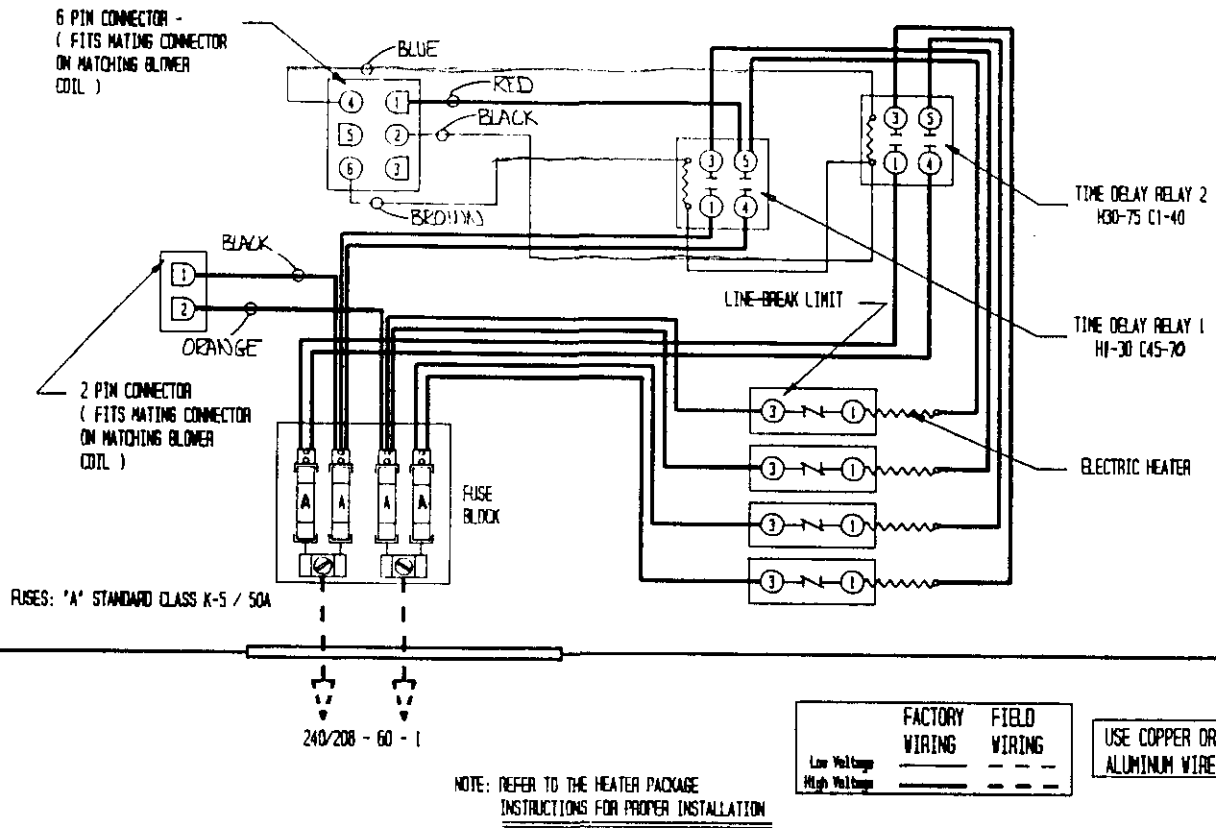

LADDER DIAGRAM

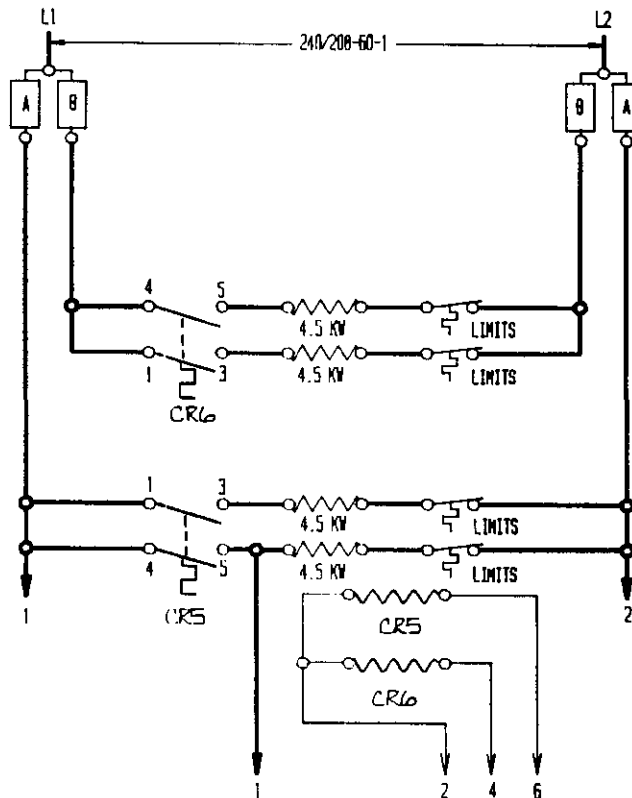

CONNECTION DIAGRAM

WARNING: ELECTRICAL SHOCK HAZARD.
DISCONNECT POWER BEFORE SERVICING.

6 PIN CONNECTOR -
(FITS MATING CONNECTOR
ON MATCHING BLOWER
COIL)

2 PIN CONNECTOR
(FITS MATING CONNECTOR
ON MATCHING BLOWER
COIL)

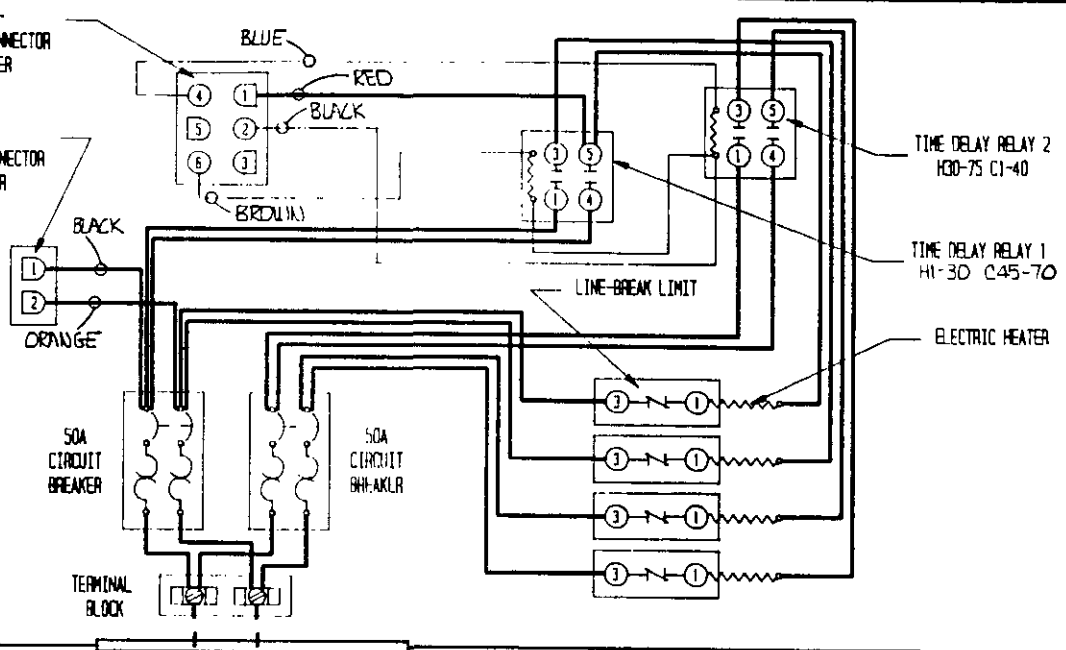

240/208 - 60 - 1

	FACTORY WIRING	FIELD WIRING
Low Voltage	—	- - -
High Voltage	- - -	—

USE COPPER OR ALUMINUM WIRE

NOTE: REFER TO THE HEATER PACKAGE INSTRUCTIONS FOR PROPER INSTALLATION

LADDER DIAGRAM

