

# **INSTALLATION INSTRUCTIONS**

## **PACKAGED AIR CONDITIONER**

### **MODELS**

**P60A6-C18HD021**

**P72A1-C18HD021**

**P72A1-F14HD021**

**FOR RESIDENTIAL AND COMMERCIAL  
HEATING/COOLING APPLICATIONS**

MANUAL 2100-184 REV. B  
SUPERSEDES REV. A  
FILE VOL. II, TAB 10

## TABLE OF CONTENTS

WALL MOUNT PACKAGE AIR CONDITIONERS . . . . .	1
Important . . . . .	2
Shipping Damage . . . . .	2
General . . . . .	2
Installation . . . . .	2
Location . . . . .	2
Typical Installation . . . . .	2
Wiring--Main Power . . . . .	3
Pressure Service Ports . . . . .	4
Air Filters . . . . .	4
Refrigerant Charge . . . . .	4
Crankcase Heaters . . . . .	5
Fan Blade Setting Dimensions . . . . .	6
Important Installer Notes . . . . .	6
 HOT GAS BYPASS SYSTEM DESIGN . . . . .	 8
System Capacity Control . . . . .	8
Bypass To Evaporator Inlet With Distributor . . . . .	9
Externally Equalized Bypass Valves. . . . .	9
Head Pressure Control . . . . .	9
ORI Valve Operation . . . . .	10
ORD Valve Operation . . . . .	11
Adjustable ORI/ORD System Operation . . . . .	11
Refrigerant Charge. . . . .	12
Troubleshooting Guide . . . . .	12
Refrigerant Piping and Flow Diagram . . . . .	13
Typical Control Circuit Wiring . . . . .	13
Wiring--Main Power . . . . .	14

## FIGURES AND TABLES

Figure 1 . . . . .	5
Figure 2 . . . . .	6
Figure 3 . . . . .	8
Figure 4 . . . . .	9
Figure 5 . . . . .	10
Figure 6 . . . . .	11
Figure 7 . . . . .	11
Figure 8 . . . . .	13
Figure 9 . . . . .	14
Figure 10. . . . .	15
Figure 11. . . . .	16
Figure 12. . . . .	17
 Table 1 . . . . .	 1
Table 2 . . . . .	3
Table 3 . . . . .	4
Table 4 . . . . .	7

TABLE 1  
ELECTRICAL DATA

Model	Rated Volts & PH	Operating Voltage Range	Max. Unit Amps	Req'd. Maximum External Fuses Or Ckt. Brk *	Minimum Circuit Ampacity	Field Power Wiring**	Ground Wire Size**
				Ckt. A	Ckt. A	Ckt. A	Ckt. A
P60A6	460-60-3	414-506	38.9	50	47	6	10
P72A1-C	460-60-3	414-506	40.9	50	50	6	10
P72A1-F	415/380-3	342-456	38.2	50	47	6	10

\*Maximum time delay fuse or HACR type circuit breaker. HACR type not applicable to 460 volt.

\*\*60 degree C copper wire size, basic unit only.

## **IMPORTANT**

The equipment covered in this manual is to be installed by trained, experienced service and installation technicians. All duct work, supply and return, must be properly sized for the design air flow requirement of the equipment. ACCA is an excellent guide to proper sizing. All duct work or portions thereof not in the conditioned space should be properly insulated in order to both conserve energy and prevent condensation or moisture damage.

## **SHIPPING DAMAGE**

Upon receipt of equipment, the carton should be checked for external signs of shipping damage. If damage is found, the receiving party must contact the last carrier immediately, preferably in writing, requesting inspection by the carrier's agent.

## **GENERAL**

The refrigerant system is completely assembled and charged. All internal wiring is complete.

The unit is designed for use with or without duct work. Flanges are provided for attaching the supply and return ducts.

These instructions explain the recommended method to install the air cooled self-contained unit and the electrical wiring connections to the unit.

These instructions and any instructions packaged with any separate equipment required to make up the entire air conditioning system should be carefully read before beginning the installation. Note particularly "Starting Procedure" and any tags and/or labels attached to the equipment.

While these instructions are intended as a general recommended guide, they do not supersede any national and/or local codes in any way. Authorities having jurisdiction should be consulted before the installation is made.

## **INSTALLATION**

Size of unit for a proposed installation should be based on heat loss calculation made according to methods of National Warm Air Heating and Air Conditioning Association. The air duct should be installed in accordance with the Standards of the National Fire Protection Association for the Installation of Air Conditioning and Ventilating Systems of Other Than Residence Type, NFPA No. 90A, and Residence Type Warm Air Heating and Air Conditioning Systems, NFPA No. 90B. Where local regulations are at a variance with instructions, installer should adhere to local codes.

## **LOCATION**

The unit must be located outside, or in a well ventilated area. It must not be in the space being heated or cooled. A sound absorbing material should be considered if the unit is to be installed in such a position or location that might cause transmission of sound or vibration to the living area or adjacent buildings.

## **TYPICAL INSTALLATION**

1. **ROOF MOUNTED**--The unit is mounted on a sturdy base on the roof of the building. Return air to the unit is brought through a single return grille (grilles with built-in filters are best, since they enable easy access for filter changing). Return air ducts are attached to the lower section of the front panel. Supply air is brought from the unit to attic duct work or to a furred down hall. Supply air duct is attached to the top of the front panel. **CAUTION:** All outdoor duct work must be thoroughly insulated and weatherproofed. All attic duct work must be thoroughly insulated. One inch thick insulation with suitable vapor barrier is recommended for both outdoor and attic runs. In rooftop installations, as in all installations, the unit must be level from side to side. However, the unit should have a pitch along the length to assure complete external drainage of precipitation and of defrost condensate.

2. **CRAWL SPACE**--Duct work installed in crawl space must be well insulated and provided with a vapor barrier. In addition, the crawl space must be thoroughly ventilated and provided with a good vapor barrier as a ground cover. It is most desirable to install the unit outdoors, rather than inside the crawl space, so that it will be readily accessible for service. In addition, it is necessary to dispose of the condensate from the outdoor coil on the heating cycle, and this is virtually impossible with the unit installed inside the crawl space.
3. **SLAB MOUNTED AT GROUND LEVEL**--This type installation is ideal for homes with a slab floor construction, where a roof mounted unit is not desired. The supply and return duct work can be run through a furred closet space.
4. **THRU-THE-WALL**--This type installation requires a suitable framework to be fabricated capable of withstanding the unit weight. Normally the unit will be insulated so as to minimize supply and return duct work.
5. **OTHER INSTALLATIONS**--Many other installations are possible with the packaged air conditioner. No matter what the installation, always consider the following facts:
  - A. Insure that the discharge air is not obstructed in any way so as to cause operation difficulties.
  - B. The indoor coil drain pan is equipped with a coupling that must be piped through a condensate drain trap to a suitable drain.
  - C. Always mount the unit in such a position that it may be easily reached for servicing and maintenance.
  - D. Insure that the unit is clear so that proper air flow over the outdoor coil will be maintained.

**TABLE 2**  
**RATED CFM AND EXTERNAL STATIC PRESSURE (ESP)**  
**WET COIL (COOLING)**

Model	Rated CFM	Rated ESP	Recommended Air Flow Range
P60A6	1775	.20	1500 - 1850 CFM
P72A1-C	1775	.20	1500 - 1850 CFM
P72A1-F	2000	.20	1800 - 2200 CFM

## **WIRING--MAIN POWER**

Refer to the unit rating plate for wire sizing information and maximum fuse size or "HACR Type" circuit breaker size. Each outdoor unit is marked with a "Minimum Circuit Ampacity". This means that the field wiring used must be sized to carry that amount of current. Some models are suitable only for connection with copper wire, while others can be wired with either copper or aluminum wire. Each unit and/or wiring diagram will be marked "Use Copper Conductors Only" or "Use Copper or Aluminum Conductors". These instructions MUST BE adhered to. Refer to the National Electrical Code for complete current carrying capacity data on the various insulation grades of wiring material.

The electrical data lists fuse and wire sizes (60 degree F copper) for all models, including the most commonly used heater sizes. Also shown are the number of field power circuits required for the various models with heaters.

The unit rating plate lists a "Maximum Time Delay Fuse" or "HACR" type circuit breaker that is to be used with the equipment. The correct size must be used for proper circuit protection and also to assure that there will be no nuisance tripping due to the momentary high starting current of the compressor motor.

## PRESSURE SERVICE PORTS

High and low pressure service ports are installed on all units so that the system operating pressures can be observed. Pressure charts can be found later in the manual covering all models on both cooling and heating cycles. It is imperative to match the correct pressure table to the unit by model number.

## AIR FILTERS

Air filters for the return air side of the system are not provided as part of the basic piece of equipment because of various types of applications for these models, and must be field supplied and installed as part of the final installation.

Prior thought should be given to return air location and placement of the air filter(s). The air filter(s) must be of adequate size and readily accessible to the operator of the equipment. Filters must be adequate in size and properly maintained for proper operation. If this is not done, excessive energy use, poor performance, and multiple service problems will result. **IT IS IMPOSSIBLE TO OVERSIZE AIR FILTERS.** Generous sizing will result in cleaner air and coils, as well as lower operating costs and extend the time between required changes. The following table shows minimum filter areas and recommended filter sizes. Actual filter sizes can vary with the installation due to single or multiple returns utilizing a filter/grille arrangement or being placed immediately ahead of the indoor coil face in the return air duct.

TABLE 3

Model	Minimum Filter Areas	Recommended Size
P60A6, P72A1	608 sq.in.(4.62 sq.ft.)	(2) 16 x 20 x 1

**NOTE:** If roof hood accessory is to be used, information on air filters may be found under that heading in this manual. Air filters are supplied as part of that package.

## REFRIGERANT CHARGE

The correct system R-22 charge is shown on the unit rating plate.

## CRANKCASE HEATERS

All units are provided with some form of compressor crankcase heat. Some single phase units utilize the compressor motor start winding in series with a portion of the run capacitor to generate heat within the compressor shell to prevent liquid refrigerant migration.

Some single and three phase models have an insertion well-type heater located in the lower section of the compressor housing. This is a self-regulating type heater that draws only enough power to maintain the compressor at a safe temperature.

Some form of crankcase heat is essential to prevent liquid refrigerant from migrating to the compressor, causing oil pump out on compressor start-up and possible valve failure due to compressing a liquid.

Refer to unit wiring diagram to find exact type of crankcase heater used.

The following decal is affixed to all outdoor units detailing start-up procedure. This is very important. Please read carefully.

FIGURE 1

**IMPORTANT**

**THESE PROCEDURES MUST BE FOLLOWED AT INITIAL START-UP AND AT ANY TIME POWER HAS BEEN REMOVED FOR 12 HOURS OR LONGER.**

TO PREVENT COMPRESSOR DAMAGE WHICH MAY RESULT FROM THE PRESENCE OF LIQUID REFRIGERANT IN THE COMPRESSOR CRANKCASE

1. MAKE CERTAIN THE ROOM THERMOSTAT IS IN THE "OFF" POSITION. (THE COMPRESSOR IS NOT TO OPERATE).
2. APPLY POWER BY CLOSING THE SYSTEM DISCONNECT SWITCH. THIS ENERGIZES THE COMPRESSOR HEATER WHICH EVAPORATES THE LIQUID REFRIGERANT IN THE CRANKCASE.
3. ALLOW 4 HOURS OR 60 MINUTES PER POUND OF REFRIGERANT IN THE SYSTEM AS NOTED ON THE UNIT RATING PLATE, WHICHEVER IS GREATER.
4. AFTER PROPERLY ELAPSED TIME THE THERMOSTAT MAY BE SET TO OPERATE THE COMPRESSOR.
5. EXCEPT AS REQUIRED FOR SAFETY WHILE SERVICING — DO NOT OPEN SYSTEM DISCONNECT SWITCH.

7961-061

## FAN BLADE SETTING DIMENSIONS

Shown in the drawing below are the correct fan blade setting dimensions for proper air delivery across the outdoor coil.

Any service work requiring removal or adjustment in the fan and/or motor area will require that the dimensions below be checked and blade adjusted in or out on the motor shaft accordingly.

FIGURE 2

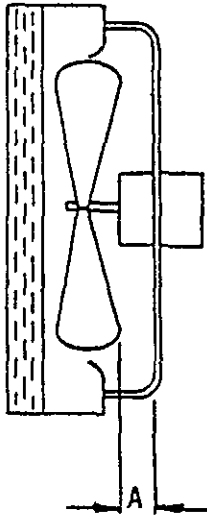

Model	Dimension A
P60A6	1.00"
P72A1	1.00"

## IMPORTANT INSTALLER NOTES

For improved start-up performance, wash the indoor coil with a dishwasher detergent.



TABLE 4

COOLING

Air Temperature Entering Outdoor Coil Degree F

Model	Return Air Temperature	Pressure	°	°	°	°	°	°	°	°	°
			75	80	85	90	95	100	105	110	115
P60A6	75 deg. DB	Low Side	65	67	69	71	73	74	76	78	79
	62 deg. WB	High Side	205	221	237	253	269	285	301	317	333
	80 deg. DB	Low Side	70	72	74	76	78	80	81	83	85
	67 deg. WB	High Side	210	227	243	260	276	293	309	326	342
P72A1	85 deg. DB	Low Side	75	77	79	81	84	85	87	89	91
	72 deg. WB	High Side	217	234	251	269	286	303	320	337	354
	75 deg. DB	Low Side	60	61	63	64	65	66	68	69	70
	62 deg. WB	High Side	197	218	240	261	283	304	326	347	368
P72A1	80 deg. DB	Low Side	64	65	67	68	70	71	73	74	75
	67 deg. WB	High Side	202	224	246	268	290	312	334	356	378
	85 deg. DB	Low Side	69	70	72	73	75	76	78	80	81
	72 deg. WB	High Side	209	232	255	277	300	323	346	368	391

Low side pressure  $\pm$  2 PSIGHigh side pressure  $\pm$  5 PSIG

Tables are based upon rated CFM (airflow) across the evaporator coil and should be found under section titled "Refrigerant Charge" elsewhere in manual. If there is any doubt as to correct operating charge being in the system, the charge should be removed, system evacuated, and recharged to serial plate instructions.

# HOT GAS BYPASS SYSTEM DESIGN

The Hot Gas Bypass System Design consists of two important modifications to the standard, proven air conditioning unit: system capacity control and head pressure control. Each of these sets of controls perform a specific function but both are necessary and dependent upon one another in the overall operation of the system.

The system is designed for outdoor operating temperature range of -20 degrees F to 115 degrees F. Both the head pressure control and the system capacity control are accomplished in the refrigerant cycle design and are independent of the electrical circuit. Therefore, it can be applied to all voltage, phase, KW and other variations of basic system design package air conditioners.

## SYSTEM CAPACITY CONTROL

The hot gas bypass valve monitors the outlet pressure of the evaporator and the return air temperature to the unit and will begin to modulate open as the load on the unit decreases to the point where the evaporator temperature is at the setpoint of the bypass valve. The bypass valves are factory adjusted to a setting of 70 psig (41 degree F evaporator temperature). This means that the compressor can be operated continuously and the minimum evaporator temperature will be maintained at 41 degrees F regardless of indoor or outdoor load conditions. Should a lower minimum evaporator temperature be desired, it can be reduced to 36 degrees F by turning the adjusting screw in the end of the remote adjusting bulb in a ccw direction. A 46 degree F evaporator temperature can be achieved by turning the adjusting screw to its full cw position. Model P72 is factory set at 55 psig.

The hot gas bypass valve (also called Discharge Bypass Valve, or DBV) responds to changes in downstream pressure (suction pressure) from the evaporator.

When the evaporating pressure is above the valve setting, the valve remains closed. As the suction pressure drops below the valve setting, the valve responds and begins to open. As with all modulating type valves, the amount of opening is proportional to the change in the variable being controlled--in this case the suction pressure. As the suction pressure continues to drop, the valve continues to open farther until the limit of the valve stroke is reached. See Figure 3.

**NOTE:** Figure 3 depicts a basic "adjustable spring type" DBV. All other Bard units employ an "adjustable remote bulb type" where the adjusting spring shown on top of valve in Figure 3 is in a 7/8" x 4.5" bulb and located in the evaporator air stream. The adjustment screw is on the open end (end opposite capillary tubing).

FIGURE 3

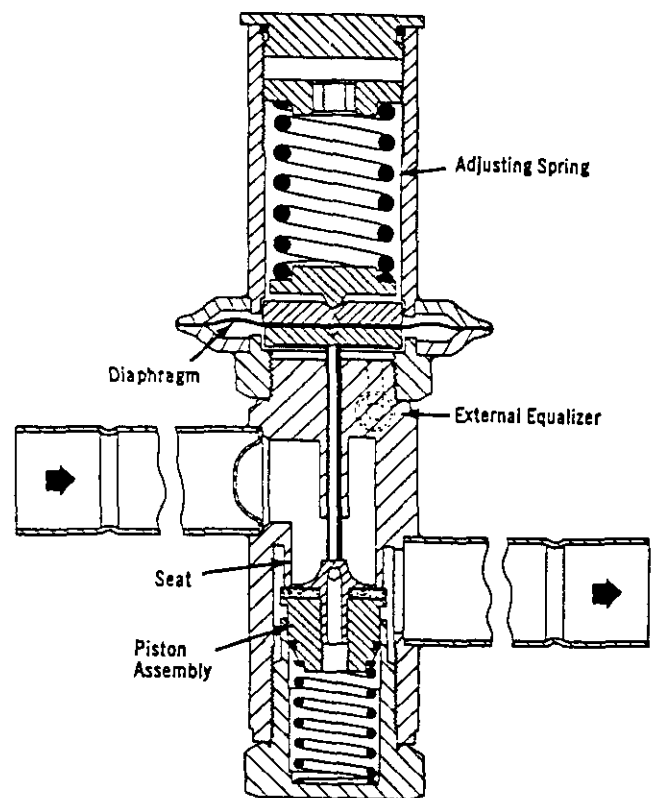

## Bypass To Evaporator Inlet With Distributor

This method of application, illustrated in Figure 4, provides distinct advantages.

The primary advantage of this method is that the system thermostatic expansion valve will respond to the increased superheat of the vapor leaving the evaporator and will provide the liquid required for desuperheating. Also the evaporator serves as an excellent mixing chamber for the bypassed hot gas and the liquid-vapor mixture from the expansion valve. This ensures a dry vapor reaching the compressor suction. Oil return from the evaporator is also improved since the velocity in the evaporator is kept high by the hot gas.

FIGURE 4

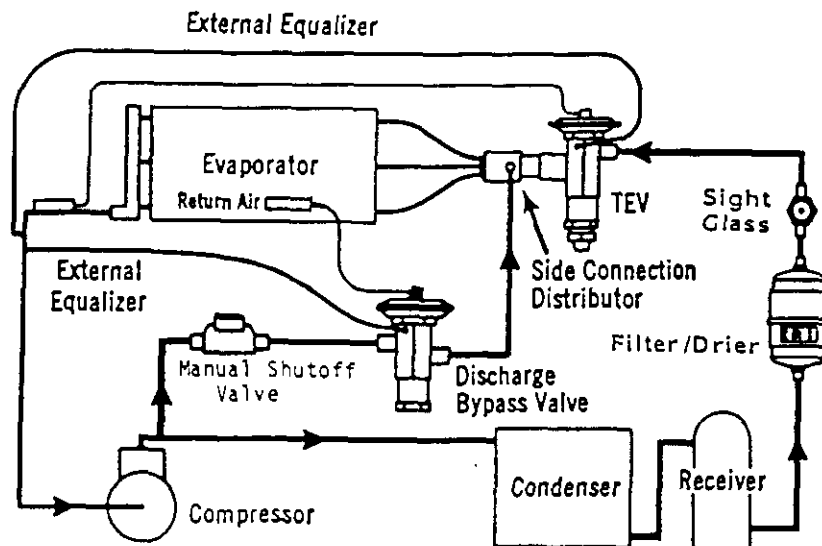

## Externally Equalized Bypass Valves

Since the primary function of the DBV is to maintain suction pressure, the compressor suction pressure is the control pressure and must be exerted on the underside of the valve diaphragm. When the DBV is applied as shown in Figure 4 where there is an appreciable pressure drop between the valve outlet and the compressor suction, the externally equalized valve must be used. This is true because when the valve opens, a sudden rise in pressure occurs at the valve outlet.

A thermal expansion valve with external equalizer and a special refrigerant distributor to allow hot gas injection at the inlet of the evaporator by feeding the side connection distributor is utilized. The expansion valve also has a rapid pressure balancing feature to allow system pressure equalization during any periods the compressor may be turned off.

## HEAD PRESSURE CONTROL

Design of air conditioning system utilizing air cooled condensing units involves two main problems which must be solved if the system is to operate reliably and economically...high ambient and low ambient operation. If the condensing unit is properly sized, it will operate satisfactorily during extremely high ambient temperatures. However, since most units will be required to operate at ambient temperatures below their design dry bulb temperature during most of the year, the solution to low ambient operation is more complex.

Without good head pressure control during low ambient operation, the system can experience both running cycle and off-cycle problem. Two running cycle problems are of prime concern:

1. Since the pressure differential across the thermostatic expansion valve port affects the rate of refrigerant flow, low head pressure generally causes insufficient refrigerant to be fed to the evaporator.
2. Any system using hot gas for compressor capacity control must have a normal head pressure to operate properly. In either case failure to have sufficient head pressure will result in low suction pressure and/or iced evaporator coils.

The primary off-cycle problem is the possible inability to get the system on-the-line if the refrigerant has migrated to the condenser. Insufficient flow through the TEV will cause a low suction pressure which results in compressor cycling.

When low ambient conditions are encountered during operation on air cooled systems with the resultant drop in condensing pressure, Head Pressure Control's purpose is to hold back enough of the condensed liquid refrigerant so that some of the condenser surface is rendered inactive. This reduction of active condensing surface results in a rise in condensing pressure and sufficient liquid line pressure for normal system operation.

A head pressure control valve and a pressure differential valve are used in conjunction with a receiver to allow for proper head pressure control. Any system using hot gas for capacity control must have a normal head pressure to operate properly.

The operation of the valve types...ORI and ORD...is discussed below. When the operation of each valve is understood, it is easier to apply them to systems that require head pressure control.

### ORI Valve Operation

The ORI head pressure control valve is an inlet pressure regulating valve and responds to changes in condensing pressure only. The valve designation stands for Opens on Rise of Inlet pressure. As shown in Figure 5, the outlet pressure is exerted on the underside of the bellows and on top of the seat disc. Since the effective area of the bellows is equal to the area of the port, the outlet pressure cancels out the inlet pressure acting on the bottom of the seat disc opposes the adjusting spring force. These two forces are the operating forces of the ORI.

When the outdoor ambient temperature changes, the ORI opens or closes in response to the change in condensing pressure. An increase in inlet pressure above the valve setting tends to open the valve. And if the ambient temperature drops, the condenser capacity is increased and the condensing pressure drops off. This causes the ORI to start to close or assume a throttling position.

The head pressure control valve will begin to throttle when the condensing pressure falls below the setting of the valve. This restricts the flow of liquid from the condenser, causing the refrigerant to back up into the condenser and raising the head pressure. The valve is factory set to maintain a nominal 225 psig minimum head pressure. Head pressures of higher than 225 psig will occur during any conditions of indoor or outdoor loading that would dictate so.

FIGURE 5

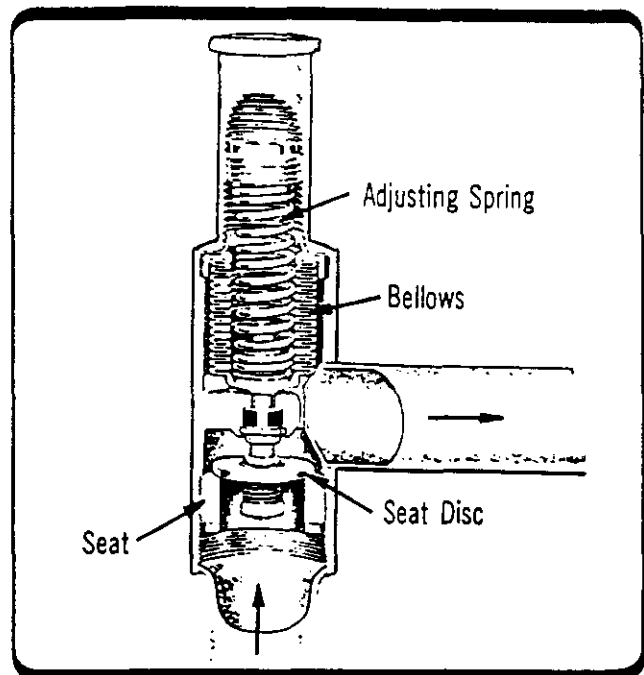

## ORD Valve Operation

The ORD valve is a pressure differential valve that responds to changes in the pressure difference across the valve, Figure 6. The valve designation stands for Opens on Rise of Differential pressure. Therefore, the ORD is dependent on some other control valve or action for its operation. And in this respect, it is used with the ORI for head pressure control.

FIGURE 6

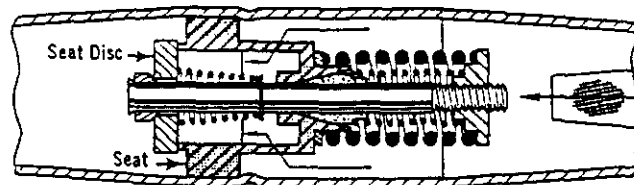

As the ORI valve starts to throttle, the flow of liquid refrigerant from the condenser, a pressure differential is created across the ORD. When the differential reaches 25 psi, the ORD starts to open and bypasses hot gas to the liquid line. As the differential increases, the ORD opens further until its full stroke is reached at a differential of 30 psi. The hot gas flowing through the pressure differential valve heats up the cold liquid being passed by the head pressure control valve, and the liquid refrigerant reaching the receiver is warm and with sufficient pressure to assure proper expansion valve operation.

## Adjustable ORI/ORD System Operation

The adjustable ORI head pressure control valve and the non-adjustable ORD pressure differential valve comprise an improved system of head pressure control.

The operation of the ORI/ORD system is such that a constant receiver pressure is maintained for normal system operation.

As shown in Figure 7, the ORI is located in the liquid line between the condenser and the receiver. And the ORD is located in a hot gas line bypassing the condenser. During periods of low ambient temperature, the condensing pressure falls until it approaches the setting of the ORI valve. The ORI then throttles, restricting the flow of liquid from the condenser. This causes refrigerant to back up in the condenser thus reducing the active condenser surface. This raises the condensing pressure. Since it is really receiver pressure that needs to be maintained, the bypass line with the ORD is required.

FIGURE 7

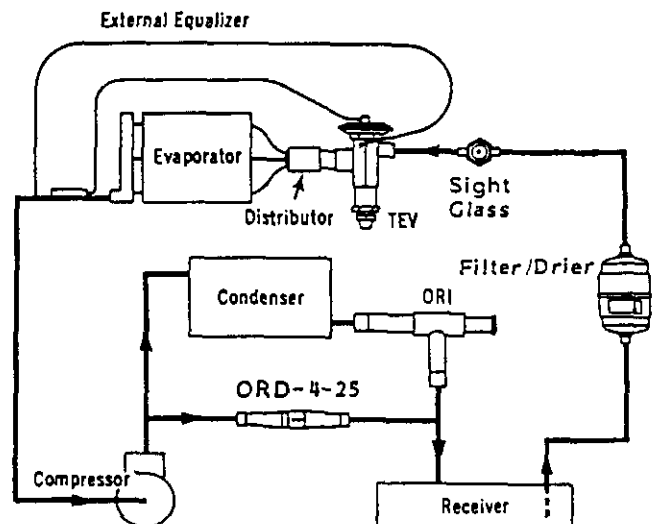

The ORD opens after the ORI has offered enough restriction to cause the differential between condensing pressure and receiver pressure to exceed 25 psi. The hot gas flowing through the ORD serves to heat up the cold liquid being passed by the ORI. Thus the liquid reaches the receiver warm and with sufficient pressure to assure proper expansion valve operation. As long as sufficient refrigerant charge is in the system, the two valves modulate the flow automatically to maintain proper receiver pressure regardless of outside ambient.

## Refrigerant Charge

When "refrigerant side" head pressure control is utilized on a system, two additional considerations must be completely analyzed. First of all, there must be the correct amount of refrigerant to flood the condenser at the lowest expected ambient and still have enough charge in the system for proper operation. A shortage of refrigerant will cause hot gas to enter the liquid line and the expansion valve, and refrigeration will cease. Too much charge doesn't cause any operating difficulties during the low ambient season; however, this will cause high head pressures during the summer season when head pressure control is not required.

Secondly, the receiver must have sufficient capacity to hold all of the liquid refrigerant in the system, since it will be returned to the receiver when high ambient conditions prevail. If the receiver is too small, liquid refrigerant will be held back in the condenser during the high ambient conditions and excessively high discharge pressure will be experienced.

The receiver has been sized to hold the necessary amount of refrigerant required during light load conditions so the head pressure control system can function properly, and also to accommodate the surplus charge that occurs under periods of normal loading at the warmer outdoor temperatures. Any erratic operating during light load conditions either inside or outside could be attributed to an undercharge of refrigerant even though the unit may operate normally at higher temperatures. Because of the complexity of the system design and operation, the only way to assure correct system charge and operating characteristics over the entire design operating range of the unit is to completely recharge the system with the total amount of R-22 shown on the unit serial plate after proper lead test and evacuation procedures have been followed.

## TROUBLESHOOTING GUIDE

Troubleshooting the refrigerant system can be quite complicated because of the number of refrigerant valves in the system. There are two devices installed in the system to aid in this process:

1. A liquid line sight glass is located directly above the filter-drier. If a solid column of refrigerant is not present during normal operation, an undercharge or defective pressure differential valve should be suspected.
2. A manual shutoff valve is installed in the feed line from the discharge line to the hot gas bypass valve. This valve is normally open but can be closed down by service personnel to help in evaluating system operation should it be necessary.

Please refer to Figure 10, Refrigerant System Troubleshooting Guide, for complete details.

## REFRIGERANT PIPING AND FLOW DIAGRAM

Earlier in this manual Figure 4 reviewed the components used in System Capacity Control and Figure 7 those used for Head Pressure Control. Please refer to Figure 8 for complete piping diagram including System Capacity and Head Pressure Control.

FIGURE 8

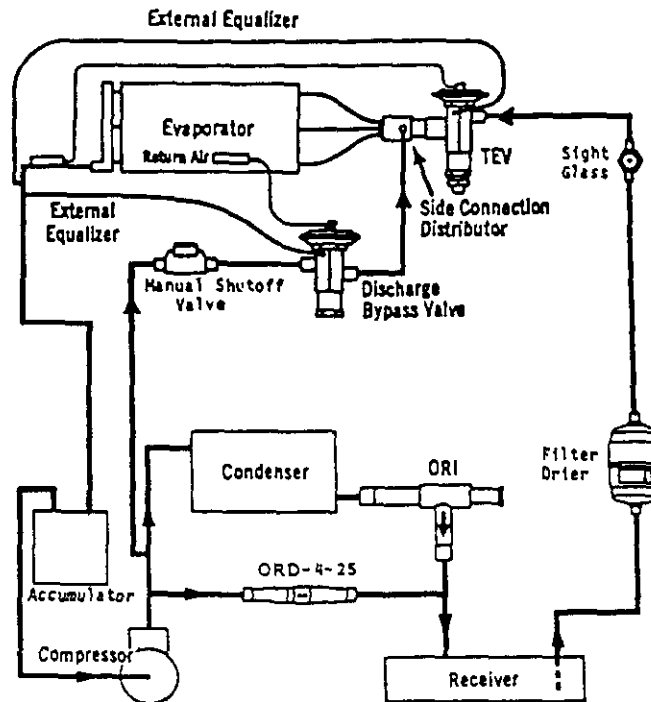

## TYPICAL CONTROL CIRCUIT WIRING

The air conditioning portion of the system is designed for continuous run type of operation for those types of installations that require cooling operation without cycling of the compressor during critical periods (see earlier discussion titled "System Capacity Control").

Many systems may also employ electric heaters for certain conditions that may necessitate heating rather than cooling operation.

The control of the space temperature is dependent upon several variables such as basic size of the air conditioner; structure design, internal heat generation from people, lights and equipment; and external weather conditions.

A generally recommended control circuit would consist of conventional heat/cool wall thermostat with an additional SPST toggle switch used to provide a manual cooling switch (continuous run type of operation). This would allow the flexibility of having the wall thermostat cycle the compressor during non-critical periods, and when the manual cooling switch is thrown (closed) the compressor would run all of the time. A secondary feature of this type of set-up is that the manual cooling switch can be activated, and at the same time the wall thermostat can be set for heating and the thermostat adjusted to the desired temperature. This would allow the electrical heater to cycle on demand to help regulate the space temperature. This type of operation may prove helpful if the basic air conditioner is way oversized or there are temporary conditions when a major portion of the heat producing equipment within the building is shut down for some reason.

Shown below is a typical 24V connection.

FIGURE 9

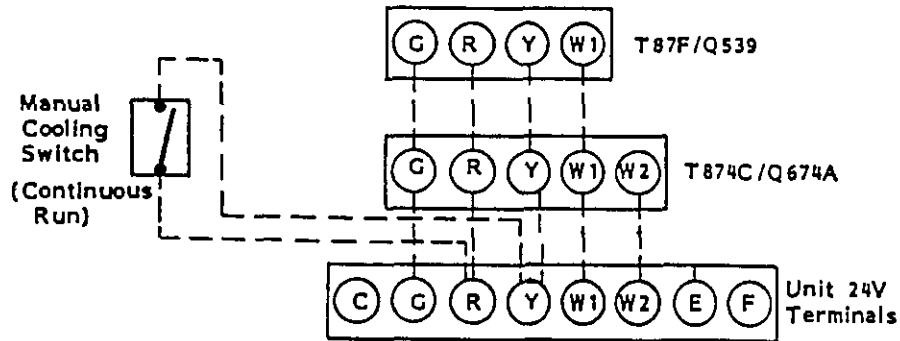

## WIRING--MAIN POWER

Refer to the rating plate for wire sizing information and maximum fuse or HACR type circuit breaker size. Each outdoor unit is marked with a Minimum Circuit Ampacity. The Minimum Circuit Ampacity for Hot Gas Bypass models is calculated for the concurrent operation of the air conditioner and electric heaters. Many Hot Gas Bypass installations require continuous operation of the compressor with the room air temperature being maintained by cycling the electric heat strips on and off. This leads to the higher than normal Minimum Circuit Ampacity of the Hot Gas Bypass units.

Since the field wiring must be sized to carry the concurrent current of both compressor and electric heaters, the field wiring must be sized to carry the Minimum Circuit Ampacity Current. See instruction sheet for further details.



FIGURE 10

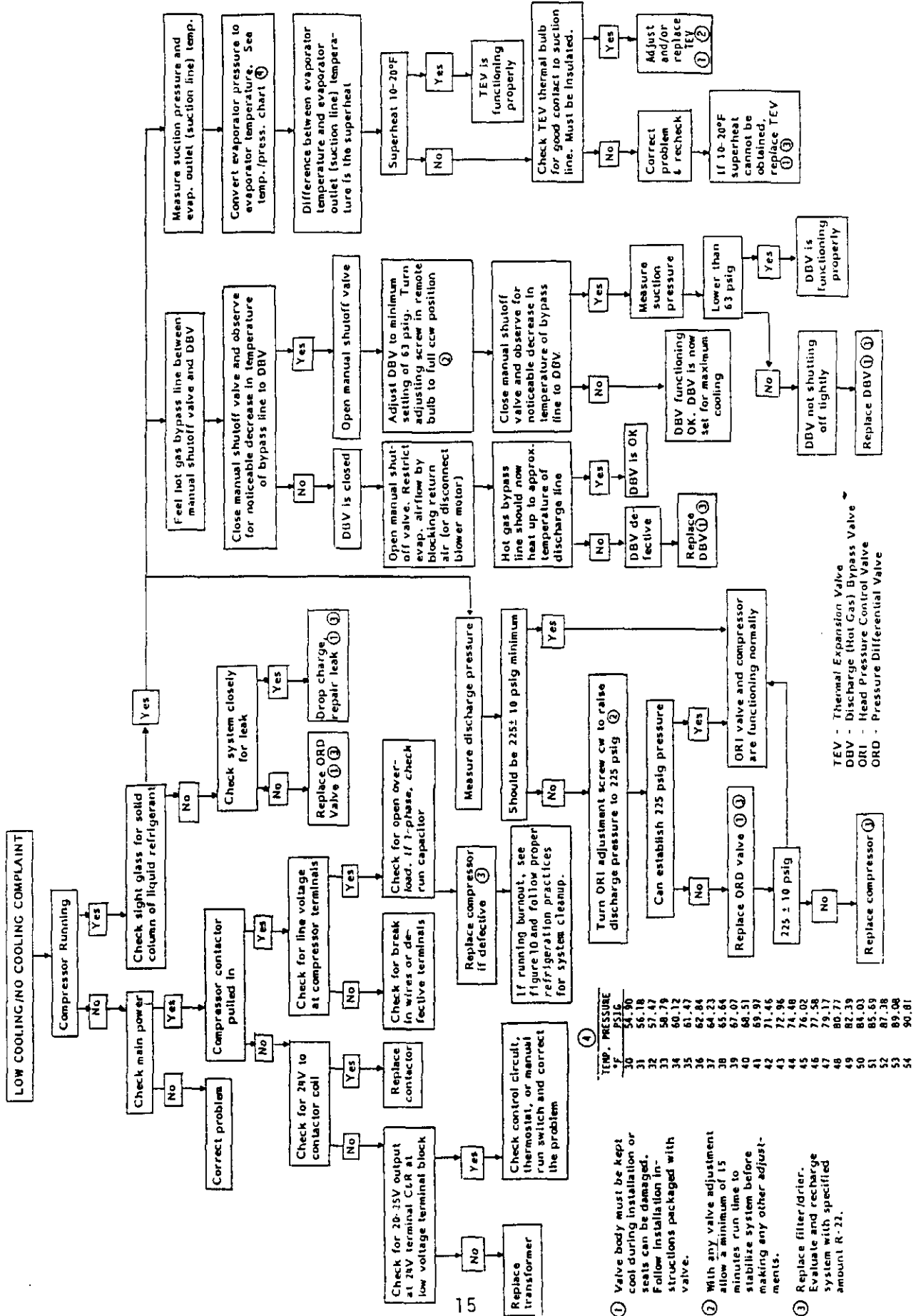

④

TEMP. °F	PRESSURE PSIG
30	54.90
31	56.18
32	57.47
33	58.79
34	60.12
35	61.47
36	62.84
37	64.23
38	65.64
39	67.07
40	68.51
41	69.97
42	71.46
43	72.96
44	74.48
45	76.02
46	77.58
47	79.17
48	80.77
49	82.39
50	84.03
51	85.69
52	87.38
53	89.08
54	90.81

- ① Valve body must be kept cool during installation or seats can be damaged. Follow installation instructions packaged with valve.
- ② With any valve adjustment allow a minimum of 15 minutes run time to stabilize system before making any other adjustments.
- ③ Replace filter/drier. Evaluate and recharge system with specified amount R-22.

TEV - Thermal Expansion Valve  
 DBV - Discharge (Hot Gas) Bypass Valve  
 ORI - Head Pressure Control Valve  
 ORD - Pressure Differential Valve

FIGURE 11

HOT GAS BYPASS SYSTEM  
TYPICAL PIPING DIAGRAM

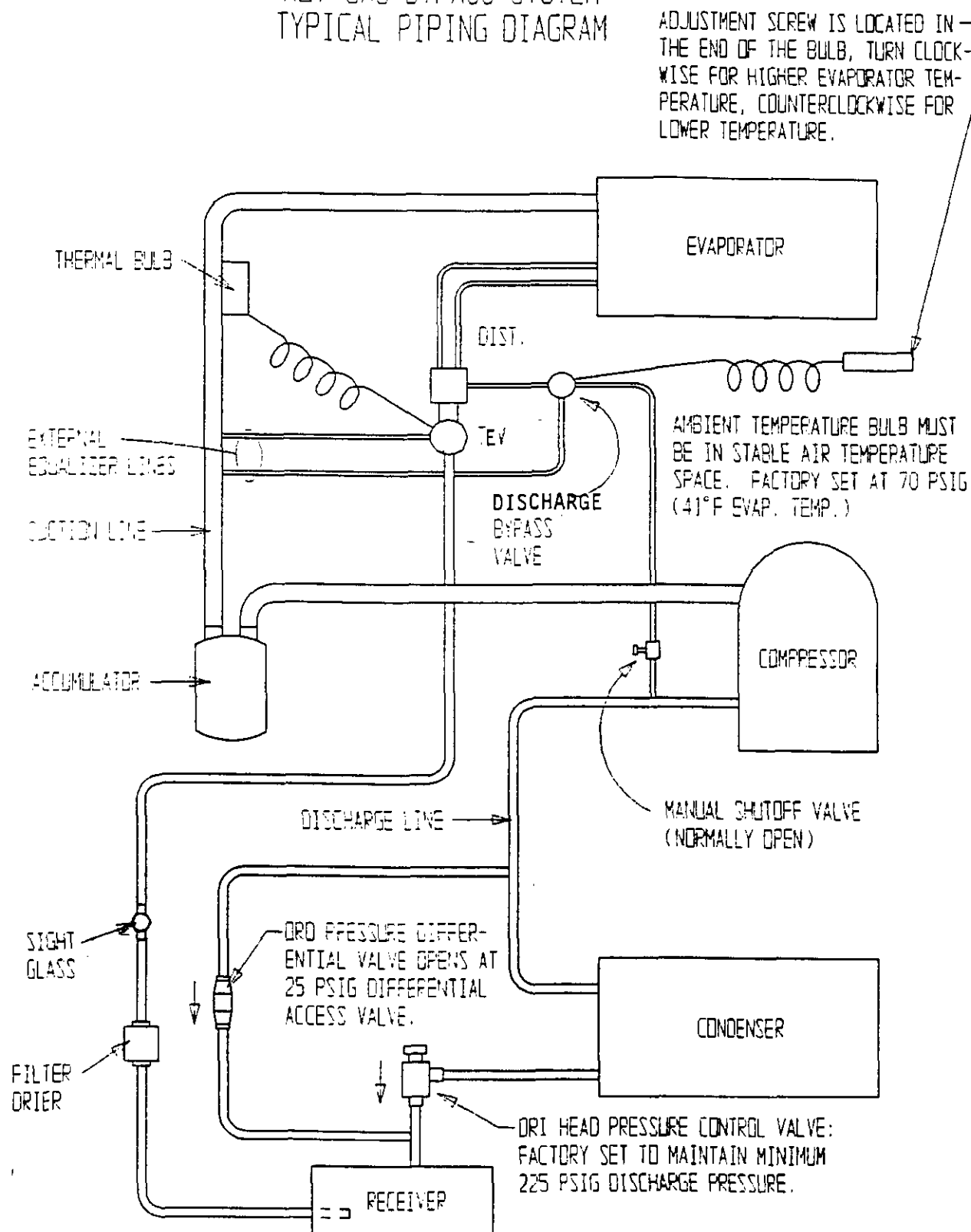
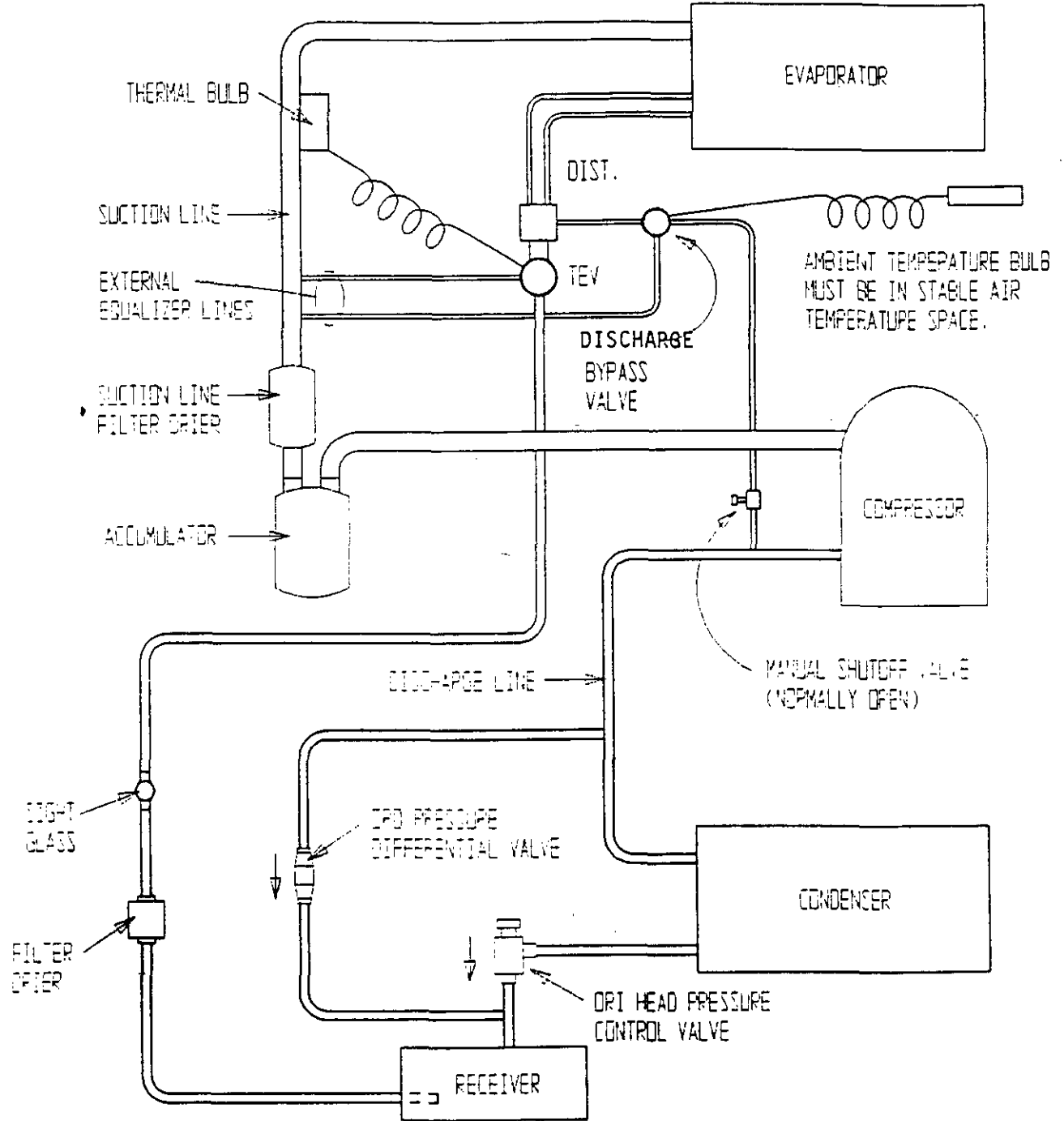

FIGURE 12

### HOT GAS BYPASS SYSTEM COMPRESSOR BURNOUT CLEANUP PROCEEDURE



IF A RUNNING BURNOUT OCCURS, REPLACE THE LIQUID LINE FILTER DRIER AND ACCUMULATOR, AND INSTALL A SUCTON LINE FILTER DRIER. CLEAN OR REPLACE THE HOT GAS BYPASS VALVE, TEV, OPD DIFFERENTIAL VALVE, ORI CONTROL VALVE, DISCHARGE, LIQUID, AND HOT GAS TUBING. THE ORI AND OPD VALVES HAVE MESH SCREENING THAT MUST BE CLEANED.