

Installation Instructions

Wall Mounted Packaged Air Conditioner

Model: **WA301, WA361**

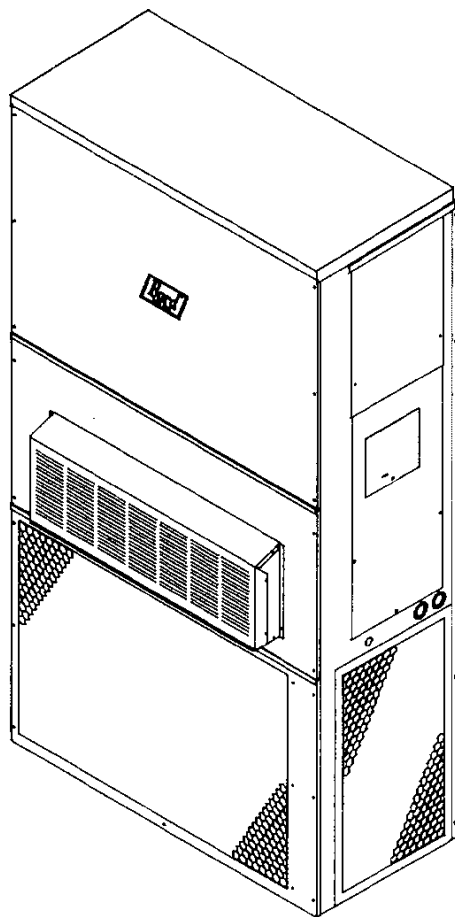

MIS-656



Bard Manufacturing Company
Bryan, Ohio 43506

*Since 1914...Moving ahead, just as
planned.*

Manual No.: 2100-192K
Supersedes: 2100-192J
File: Volume III, Tab 16
Date: 04-12-99

© Copyright 1999

Contents

Getting Other Information and Publications	1
For more information, contact these publishers	1
Wall Mount General Information	2
Air Conditioner Wall Mount Model Nomenclature	2
Shipping Damage	5
General 5	
Duct Work 5	
Filters 5	
Fresh Air Intake	6
Condensate Drain	6
Installation Instructions	7
Wall Mounting Information	7
Mounting the Unit	7
Top Outlet Only	7
Wiring — Main Power	7
Wiring — Low Voltage Wiring	8

Start Up	12
Important Installer Note	12
Crankcase Heaters	12
Service Hints	12
Sequence of Operation	12
Compressor Control Module	12
Adjustments	13
Pressure Service Ports	13
Troubleshooting	14
Fan Blade Setting Dimensions	14
Removal of Fan Shroud	14
Refrigerant Charge	14
Optional Accessories	16

Figures	
Figure 1 Unit Dimensions	3
Figure 2 Blower Damper Assembly	6
Figure 3 Mounting Instructions	8
Figure 4 Wall-Mounting Instructions	9
Figure 5 Wall-Mounting Instructions	9
Figure 6 Common Wall-Mounting Installations ...	10
Figure 7 Electric Heat Clearances	11
Figure 8 Low Voltage Wiring	11
Figure 9 Start Up Label	12
Figure 10 Fan Blade Setting	14

Tables	
Table 1 Electrical Specifications	2
Table 2 Dimensions of Basic Unit	3
Table 3 Electric Heat Table	4
Table 4 Operating Voltage Range	8
Table 5 Thermostat Wire Size	8
Table 6 Wall Thermostat and Subbase Combinations	8
Table 7 Fan Blade Dimensions	14
Table 8 Suction Line Temperatures	14
Table 9 Indoor Blower Performance	14
Table 10 CFM and ESP	15
Table 11 Maximum ESP of Operation Electric Heat Only	15
Table 12 Cooling Pressure	15
Table 13 Optional Accessories	16

Getting Other Information and Publications

These publications can help you install the air conditioner or heat pump. You can usually find these at your local library or purchase them directly from the publisher. Be sure to consult current edition of each standard.

National Electrical Code ANSI/NFPA 70

Standard for the Installation of Air Conditioning and Ventilating Systems ANSI/NFPA 90A

Standard for Warm Air Heating and Air Conditioning Systems ANSI/NFPA 90B

Load Calculation for Residential Winter and Summer Air Conditioning ACCA Manual J

Duct Design for Residential Winter and Summer Air Conditioning and Equipment Selection ACCA Manual D

For more information, contact these publishers:

ACCA Air Conditioning Contractors of America
1712 New Hampshire Avenue NW
Washington, DC 20009
Telephone: (202) 483-9370
Fax: (202) 234-4721

ANSI American National Standards Institute
11 West Street, 13th Floor
New York, NY 10036
Telephone: (212) 642-4900
Fax: (212) 302-1286

ASHRAE American Society of Heating Refrigerating, and Air Conditioning Engineers, Inc.
1791 Tullie Circle, N.E.
Atlanta, GA 30329-2305
Telephone: (404) 636-8400
Fax: (404) 321-5478

NFPA National Fire Protection Association
Batterymarch Park
P.O. Box 9101
Quincy, MA 02269-9901
Telephone: (800) 344-3555
Fax: (617) 984-7057

Manufactured under the following U.S. patent numbers:
5,485,878; 5,301,744; 5,002,116; 4,924,934; 4,875,520;
4,825,936; 4,432,409.

WALL MOUNT GENERAL INFORMATION

Air Conditioner Wall Mount Model Nomenclature

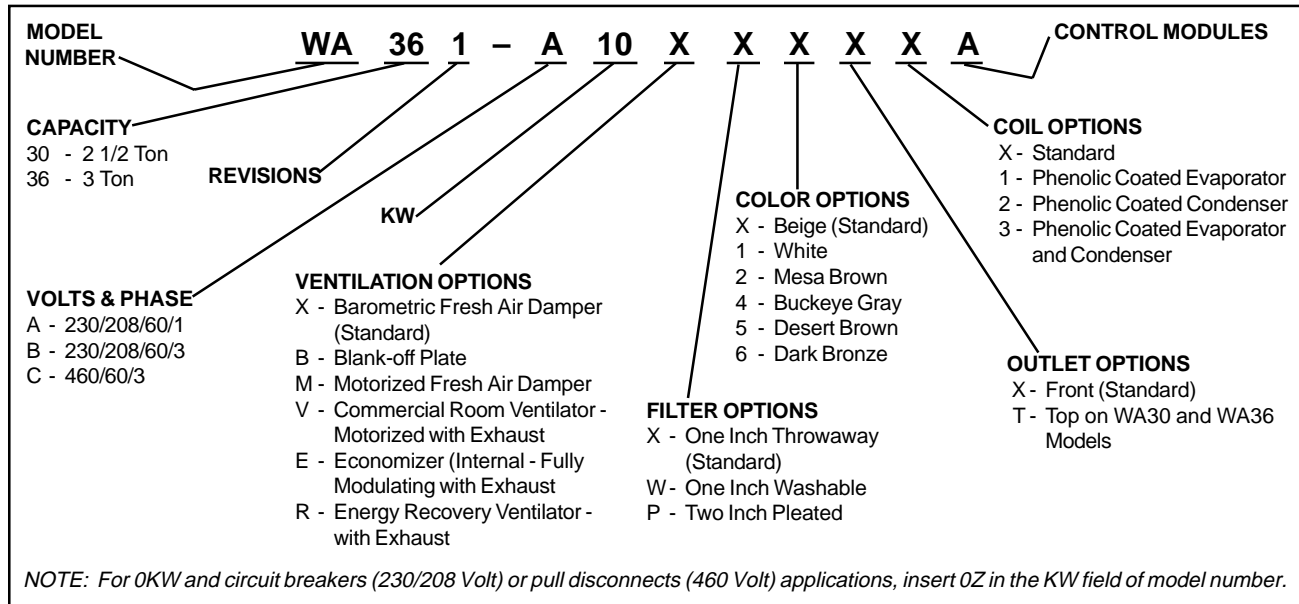

TABLE 1 – ELECTRICAL SPECIFICATIONS

Model	Rated Volts & Phase	No. Field Power Circuits	③ Minimum Circuit Ampacity	① Maximum External Fuse or Ckt. Breaker	② Field Power Wire Size	② Ground Wire Size	③ Minimum Circuit Ampacity		① Maximum External Fuse or Ckt. Breaker		② Field Power Wire Size		② Ground Wire Size	
							CKT A	CKT B	CKT A	CKT B	CKT A	CKT B	CKT A	CKT B
WA301-A00, A0Z	230/208-1	1	24	35	8	10	---	---	---	---	---	---	---	---
A05		1	31	35	8	10	---	---	---	---	---	---	---	
A10		1	57	60	6	10	---	---	---	---	---	---	---	
A15		1 or 2	83	90	4	8	55	26	60	30	4	10	8	10
WA301-B00, B0Z	230/208-3	1	17	20	12	12	---	---	---	---	---	---	---	
B09		1	32	35	8	10	---	---	---	---	---	---		
B15		1	50	50	8	10	---	---	---	---	---	---		
WA301-C00, C0Z	460-3	1	10	15	14	14	---	---	---	---	---	---		
C09		1	17	20	12	12	---	---	---	---	---			
C15		1	26	30	10	10	---	---	---	---	---			
WA361-A00, A0Z	230/208-1	1	27	35	8	10	---	---	---	---	---	---		
A05		1	31	35	8	10	---	---	---	---	---			
A10		1	57	60	6	10	---	---	---	---	---			
A15		1 or 2	83	90	4	8	55	26	60	30	4	10	8	10
WA361-B00, B0Z	230/208-3	1	20	25	10	10	---	---	---	---	---	---		
B09		1	32	35	8	10	---	---	---	---	---			
B15		1	50	50	8	10	---	---	---	---	---			
WA361-C00, C0Z	460-3	1	10	15	14	14	---	---	---	---	---	---		
C09		1	17	20	12	12	---	---	---	---	---			
C15		1	26	30	10	10	---	---	---	---	---			

- ① Maximum size of the time delay fuse or HACR type circuit breaker for protection of field wiring conductors.
- ② Based on 75° copper wire. All wiring must conform to the National Electrical Code and all local codes.
- ③ These "Minimum Circuit Ampacity" values are to be used for sizing the field power conductors. Refer to the National Electric Code (latest revision), Article 310 for power conductor sizing. **CAUTION:** When more than one field power conductor circuit is run through one conduit, the conductors must be derated. Pay special attention to note 8 of table 310 regarding Ampacity Adjustment Factors when more than three conductors are in a raceway.

TABLE 2
DIMENSIONS OF BASIC UNIT (Nominal)

Model	Width (W)	Depth (D)	Height (H)	Supply		Return		E	F	G	I	J	K	L	M	N	O	P	Q	R	S	T
				A	B	C	B															
WA30 WA36	38.200	17.125	70.563	7.88	27.88	13.88	27.88	40.00	18.50	25.75	17.93	26.75	28.75	29.25	27.00	2.75	39.19	22.75	9.14	4.19	12.00	5.00

FIGURE 1
UNIT DIMENSIONS

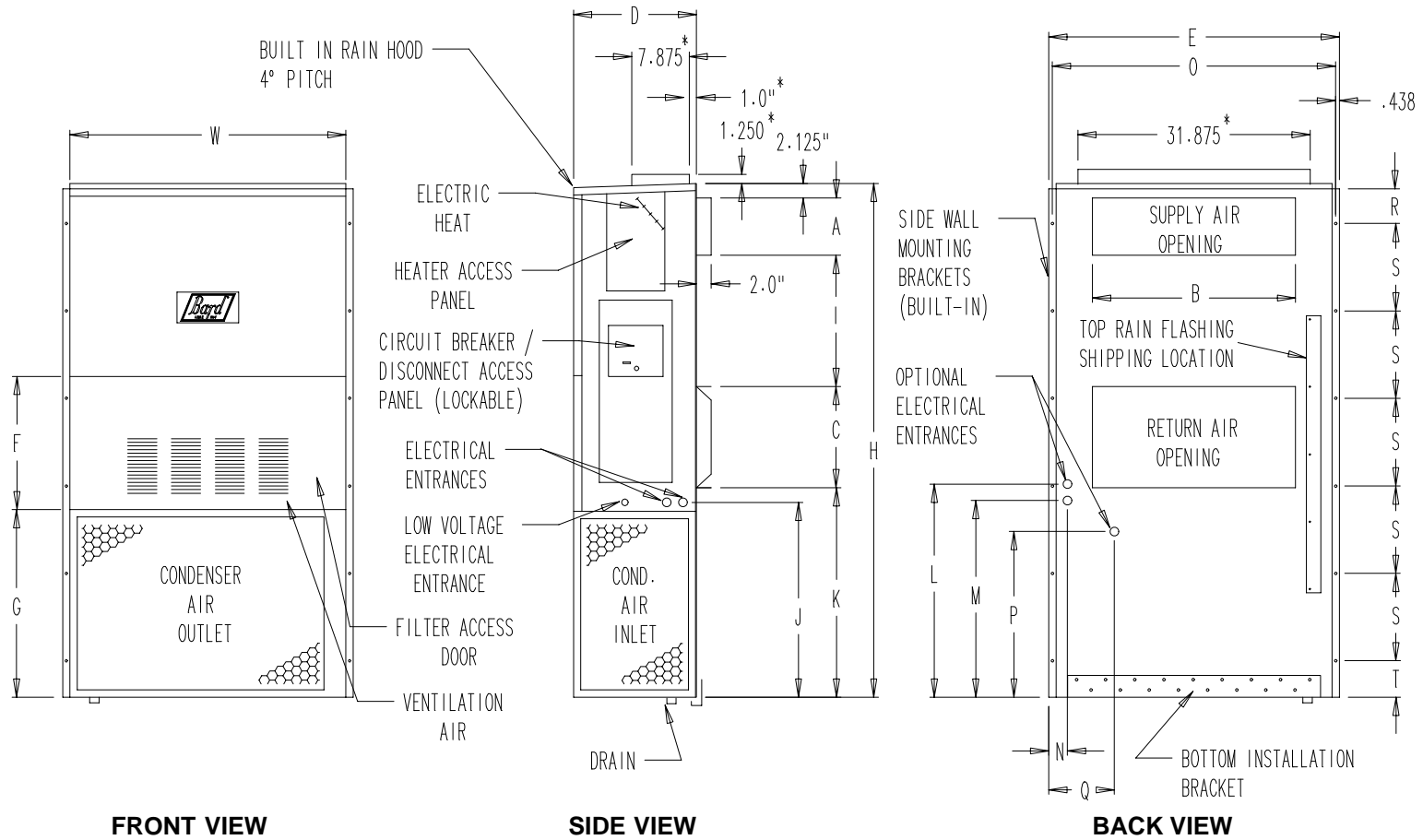

* Optional top outlet (factory installed only) for WA30 and WA36 models only.

**TABLE 3
ELECTRIC HEAT TABLE**

Models	WA301-A				WA301-B				WA301-C		WA361-A				WA361-B				WA361-C	
	240V-1		208V-1		240V-3		208V-3		460V-3		240V-1		208V-1		240V-3		208V-3		460V-3	
KW	AMPS	BTUH	AMPS	BTUH	AMPS	BTUH	AMPS	BTUH	AMPS	BTUH	AMPS	BTUH	AMPS	BTUH	AMPS	BTUH	AMPS	BTUH	AMPS	BTUH
5.0	20.8	17,065	18.1	12,800							20.8	17,065	18.1	12,800						
8.0	33.3	27,300	28.8	20,475							33.3	27,300	28.8	20,475						
10.0	41.6	34,130	36.2	25,600							41.6	34,130	36.2	25,600						
15.0											62.5	51,200	54.1	38,400						
6.0					14.4	20,500	12.5	15,360	7.2	20,475					14.4	20,500	12.5	15,360	7.2	20,475
9.0					21.7	30,600	18.7	23,030	10.8	30,700					21.7	30,600	18.7	23,030	10.8	30,700
15.0									18.0	51,200					36.2	38,400	31.2	38,400	18.0	51,200

SHIPPING DAMAGE

Upon receipt of equipment, the carton should be checked for external signs of shipping damage. If damage is found, the receiving party must contact the last carrier immediately, preferably in writing, requesting inspection by the carrier's agent.

GENERAL

The equipment covered in this manual is to be installed by trained, experienced service and installation technicians.

The refrigerant system is completely assembled and charged. All internal wiring is complete.

The unit is designed for use with or without duct work. Flanges are provided for attaching the supply and return ducts.

These instructions explain the recommended method to install the air cooled self-contained unit and the electrical wiring connections to the unit.

These instructions and any instructions packaged with any separate equipment required to make up the entire air conditioning system should be carefully read before beginning the installation. Note particularly "Starting Procedure" and any tags and/or labels attached to the equipment.

While these instructions are intended as a general recommended guide, they do not supersede any national and/or local codes in any way. Authorities having jurisdiction should be consulted before the installation is made. See Page 1 for information on codes and standards.

Size of unit for a proposed installation should be based on heat loss calculation made according to methods of Air Conditioning Contractors of America (ACCA). The air duct should be installed in accordance with the Standards of the National Fire Protection Association for the Installation of Air Conditioning and Ventilating Systems of Other Than Residence Type, NFPA No. 90A, and Residence Type Warm Air Heating and Air Conditioning Systems, NFPA No. 90B. Where local regulations are at a variance with instructions, installer should adhere to local codes.

DUCT WORK

All duct work, supply and return, must be properly sized for the design air flow requirement of the equipment. Air Conditioning Contractors of America (ACCA) is an excellent guide to proper sizing. All duct work or portions thereof not in the conditioned space should be properly insulated in order to both conserve energy and prevent condensation or moisture damage.

Refer to Table 10 for maximum static pressure available for duct design.

Design the duct work according to methods given by the Air Conditioning Contractors of America (ACCA). When duct runs through unheated spaces, it should be insulated with a minimum of 1 inch of insulation. Use insulation with a vapor barrier on the outside of the insulation. Flexible joints should be used to connect the duct work to the equipment in order to keep the noise transmission to a minimum.

A 1/4 inch clearance to combustible material for the first 3 feet of duct attached to the outlet air frame is required. See Wall Mounting Instructions and Figures 3 and 4 for further details.

Ducts through the walls must be insulated and all joints taped or sealed to prevent air or moisture entering the wall cavity.



Some installations may not require any return air duct. A metallic return air grille is required with installations not requiring a return air duct. The spacing between louvers on the grille shall not be larger than 5/8 inches.

Any grille that meets the 5/8 inch louver criteria may be used. It is recommended that Bard Return Air Grille Kit RG-2 through RG-5 or RFG-2 through RFG-5 be installed when no return duct is used. Contact distributor or factory for ordering information. If using a return air filter grille, filters must be of sufficient size to allow a maximum velocity of 400 fpm.

FILTERS

A 1 inch throw away filter is supplied with each unit. The filter slides into position making it easy to service. This filter can be serviced from the outside by removing the service door. A 1 inch washable filter and a 2 inch pleated filter are also available as optional accessories. The internal filter brackets are adjustable to accommodate the 2 inch filter by loosening 2 screws in each bracket assembly and sliding the brackets apart to the required width and retightening the 4 screws.

FRESH AIR INTAKE

All units are built with fresh air inlet slots punched in the service panel.

If the unit is equipped with the fresh air damper assembly, the assembly is shipped already attached to the unit. The damper blade is locked in the closed position. To allow the damper to operate, the maximum and minimum blade position stops must be installed. See Figure 2.

All capacity, efficiency and cost of operation information as required for Department of Energy "Energyguide" Fact Sheets is based upon the fresh air blank-off plate in place and is recommended for maximum energy efficiency.

The blank-off plate is available upon request from the factory and is installed in place of the fresh air damper shipped with each unit.

CONDENSATE DRAIN

A plastic drain hose extends from the drain pan at the top of the unit down to the unit base. There are openings in the unit base for the drain hose to pass through. In the event the drain hose is connected to a drain system of some type, it must be an open or vented type system to assure proper drainage.

Figure 2
FRESH AIR Damper Assembly

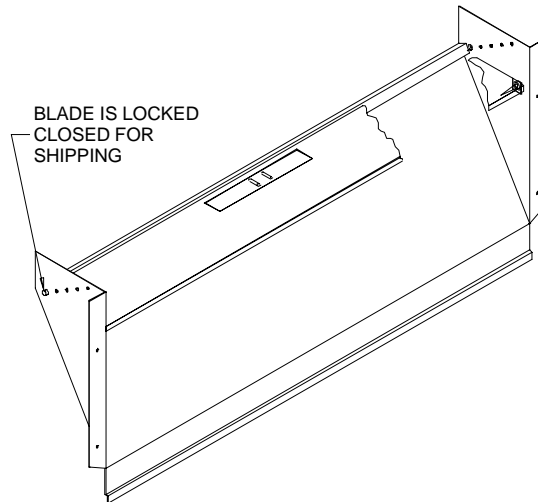

MIS-938

INSTALLATION INSTRUCTIONS

WALL MOUNTING INFORMATION

1. Two holes, for the supply and return air openings, must be cut through the wall as shown in Figure 3.
2. On wood-frame walls, the wall construction must be strong and rigid enough to carry the weight of the unit without transmitting any unit vibration.

WARNING

Fire hazard can result if 1/4 inch clearance to combustible materials for supply air duct is not maintained. See Figure 3.

3. Concrete block walls must be thoroughly inspected to insure that they are capable of carrying the weight of the installing unit.

MOUNTING THE UNIT

1. These units are secured by wall mounting brackets which secure the unit to the outside wall surface at both sides. A bottom mounting bracket is provided for ease of installation, but is not required.
2. The unit itself is suitable for “0” inch clearance, but the supply air duct flange and the first 3 feet of supply air duct require a minimum of 1/4 inch clearance to combustible material. If a combustible wall, use a minimum of 28-1/2" x 8-1/2" dimensions for sizing. However, it is generally recommended that a 1 inch clearance is used for ease of installation and maintaining the required clearance to combustible material. The supply air opening would then be 30" x 10". See Figures 3 and 4 for details.

WARNING

Failure to provide the 1/4 inch clearance between the supply duct and a combustible surface for the first 3 feet of duct can result in fire.

3. Locate and mark lag bolt locations and bottom mounting bracket location. See Figure 3.
4. Mount bottom mounting bracket, if used.
5. Hook top rain flashing under back bend of top. Top rain flashing is shipped secured to the right side of the back.
6. Position unit in opening and secure with 5/16 lag bolts; use 7/8 inch diameter flat washers on the lag bolts.
7. Secure rain flashing to wall and caulk across entire length of top. See Figure 3.

8. For additional mounting rigidity, the return air and supply air frames or collars can be drilled and screwed or welded to the structural wall itself (depending upon wall construction). Be sure to observe required clearance if combustible wall.
9. On side by side installations, maintain a minimum of 20 inches clearance on right side to allow access to heat strips and control panel and to allow proper airflow to the outdoor coil. Additional clearance may be required to meet local or national codes.

TOP OUTLET ONLY

1. Remove airframe angles from the back of the unit.
2. Coat angles with two 1/8" beads of silicone as shown. Silicone is shipped in the control panel. See Figure 5.
3. Secure angles to the top of the unit with 14 screws provided. Use of prepunched holes provided. Do not relocate. See Figure 5.
4. After installation duct work, seal around airframe and duct work to provide a rain tight seal.
5. It is strongly recommended, but not required, that this unit be installed under a soffit area large enough to shield the top of the unit. See Figure 6.

WIRING — MAIN POWER

Refer to the unit rating plate for wire sizing information and maximum fuse or “HACR Type” circuit breaker size. Each outdoor unit is marked with a “Minimum Circuit Ampacity”. This means that the field wiring used must be sized to carry that amount of current. Depending on the installed KW of electric heat, there may be two field power circuits required. If this is the case, the unit serial plate will so indicate. All models are suitable only for connection with copper wire. Each unit and/or wiring diagram will be marked “Use Copper Conductors Only”. These instructions **must be** adhered to. Refer to the National Electrical Code (NEC) for complete current carrying capacity data on the various insulation grades of wiring material. All wiring must conform to NEC and all local codes.

The electrical data lists fuse and wire sizes (75°C copper) for all models, including the most commonly used heater sizes. Also shown are the number of field power circuits required for the various models with heaters.

The unit rating plate lists a “Maximum Time Delay Relay Fuse” or “HACR Type” circuit breaker that is to be used with the equipment. The correct size must be used for proper circuit protection and also to assure that there will be no nuisance tripping due to the momentary high starting current of the compressor motor.

The disconnect access door on this unit may be locked to prevent unauthorized access to the disconnect. To convert for the locking capability, bend the tab located in the

bottom left hand corner of the disconnect opening under the disconnect access panel straight out. This tab will now line up with the slot in the door. When shut, a padlock may be placed through the hole in the tab preventing entry.

WIRING — LOW VOLTAGE WIRING

230/208V, 1 phase and 3 phase equipment dual primary voltage transformers. All equipment leaves the factory wired on 240V tap. For 208V operation, reconnect from 240V to 208V tap. The acceptable operating voltage range for the 240 and 208V taps are:

**TABLE 4
OPERATING VOLTAGE RANGE**

TAP	RANGE
240V	253 - 216
208V	220 - 187

NOTE: The voltage should be measured at the field power connection point in the unit and while the unit is operating at full load (maximum amperage operating condition.)

Five (5) wires should be run from thermostat subbase to the 24V terminal board in the unit. A five conductor, 18 gauge copper, color-coded thermostat cable is recommended. The connection points are shown in Figure 10.

**TABLE 5
THERMOSTAT WIRE SIZE**

Transformer VA	FLA	Wire Gauge	Maximum Distance In Feet
55	2.3	20 gauge	45
		18 gauge	60
		16 gauge	100
		14 gauge	160
		12 gauge	250

**TABLE 6
WALL THERMOSTAT and SUBBASE COMBINATIONS**

Thermostat	Subbase	Predominate Features
8403-002 T87F3111	8404-003 Q539A1220	1 stage heat, 1 stage cool System: heat-off-cool Fan: auto-on
8403-041 T8034C	---	1 stage heat, 1 stage cool System: heat-off-cool Fan: auto-on
8403-019 T874C1760	8404-012 Q674A1001	1 stage cool, 2 stage heat System: heat-auto-cool Fan: auto-on
8403-021 T874D1934	8404-012 Q674A1001	2 stage cool, 2 stage heat System: heat-auto-cool Fan: auto-on
8403-035 1F95-80	---	2 stage cool, 2 stage heat Electronic 7 day programming
8403-043 CM-200	---	1 stage heat, 1 stage cool System: heat-off-cool Fan: auto-on

FIGURE 3 — MOUNTING INSTRUCTIONS

	A	B	C	D	E
REQUIRED DIMENSIONS TO MAINTAIN 1/4" MIN. CLEARANCE FROM COMBUSTIBLE MATERIALS	28 1/2	8 1/2	5 1/4	3 13/16	17 5/8
REQUIRED DIMENSIONS TO MAINTAIN RECOMMENDED 1" CLEARANCE FROM COMBUSTIBLE MATERIALS	30	10	4 1/2	3 1/16	16 7/8

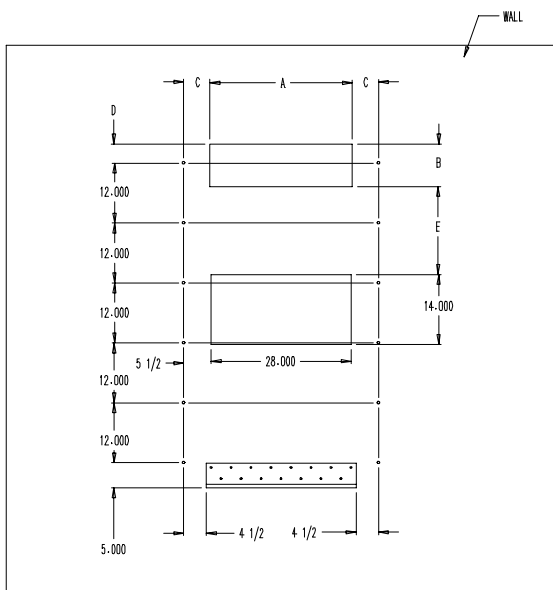

NOTE: It is recommended that a bead of silicone caulking be placed behind the side mounting flanges and under the top flashing at the time of installation.

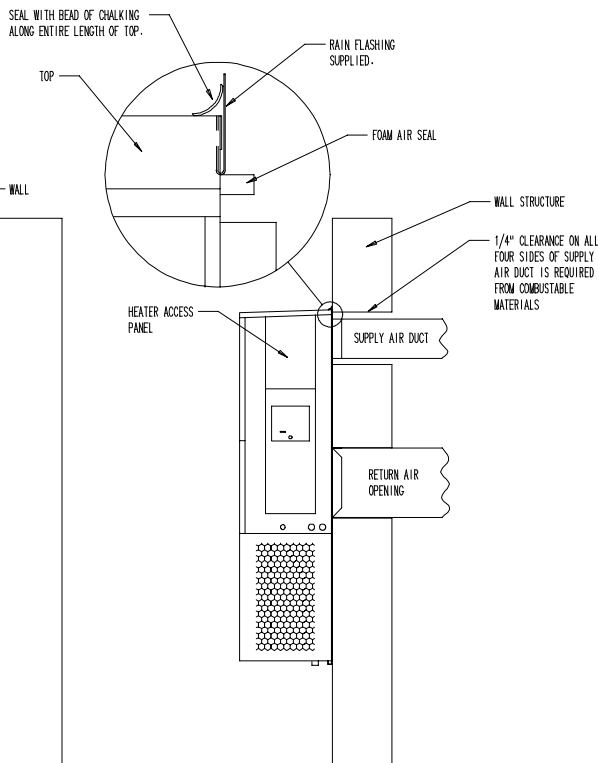

MIS-311

FIGURE 4
WALL-MOUNTING INSTRUCTIONS

SEE FIGURE 3 – MOUNTING INSTRUCTIONS

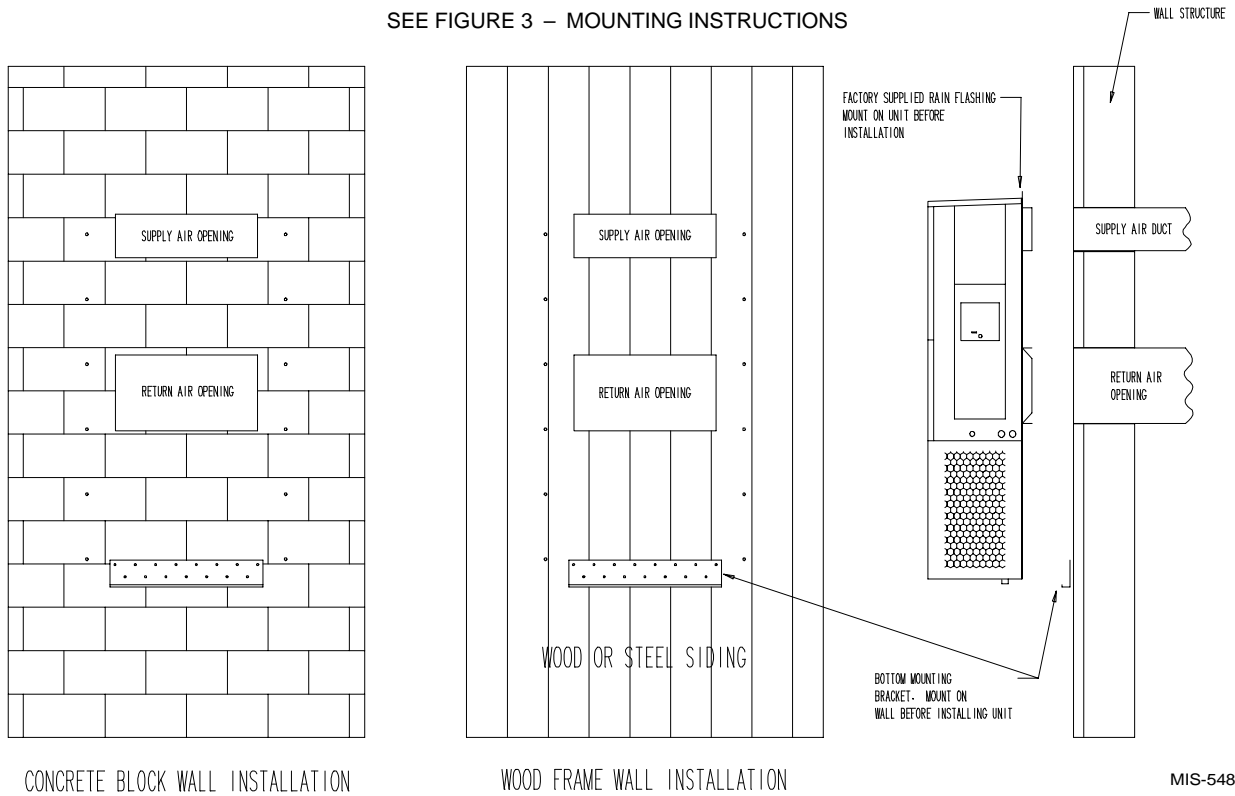
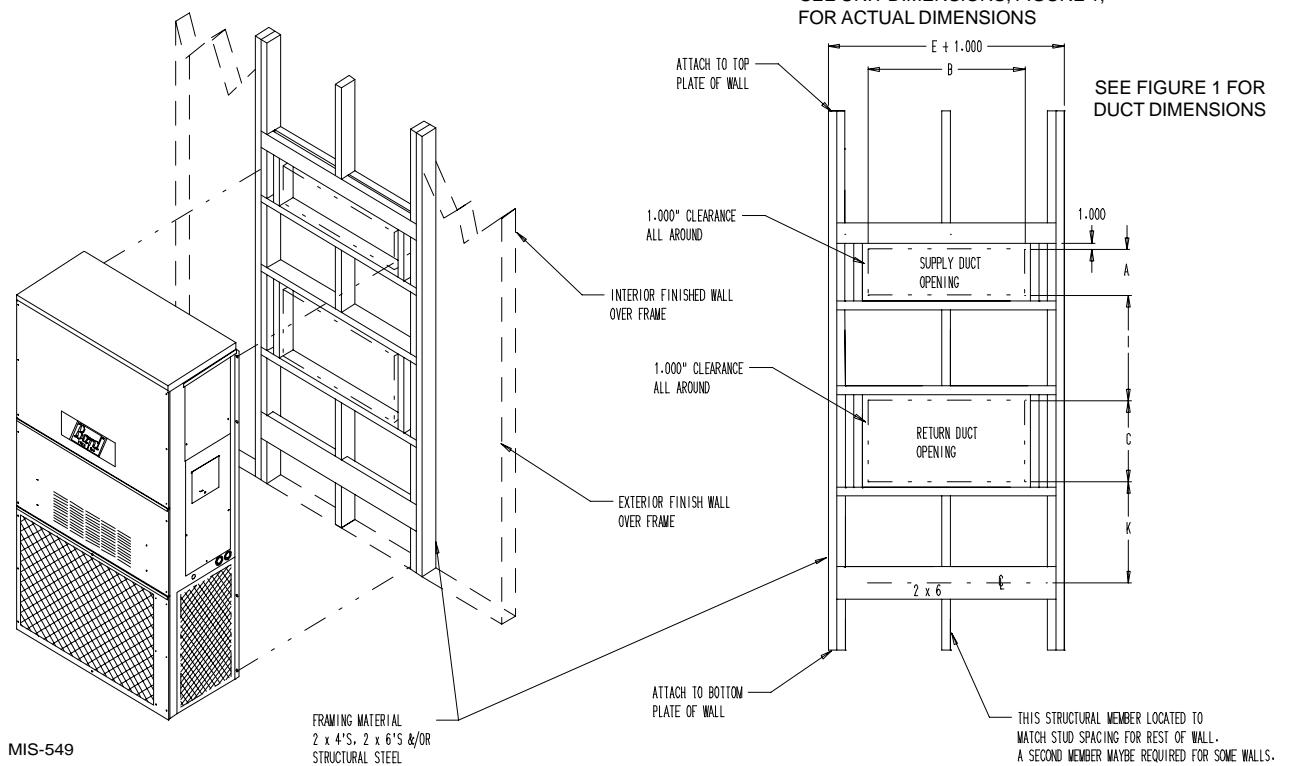
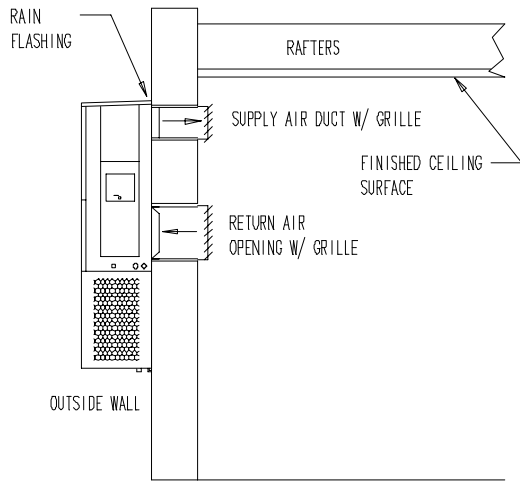

FIGURE 5
WALL-MOUNTING INSTRUCTIONS

SEE UNIT DIMENSIONS, FIGURE 1,
FOR ACTUAL DIMENSIONS



**FIGURE 6
COMMON WALL-MOUNTING INSTALLATIONS**



FREE AIR FLOW
NO DUCT

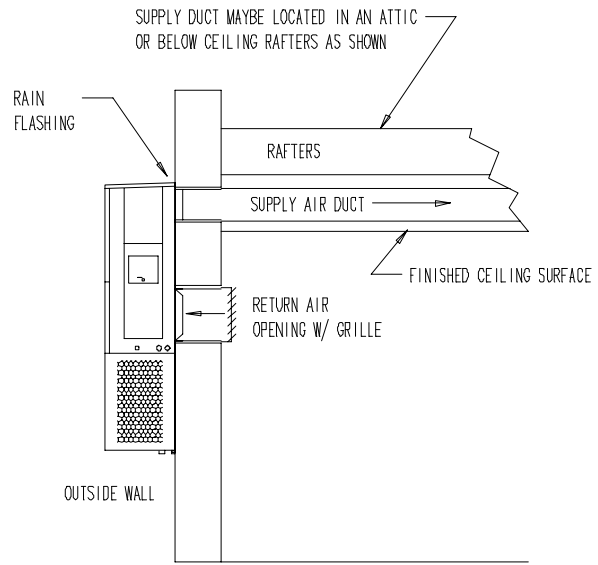

DUCTED SUPPLY
RETURN AT UNIT

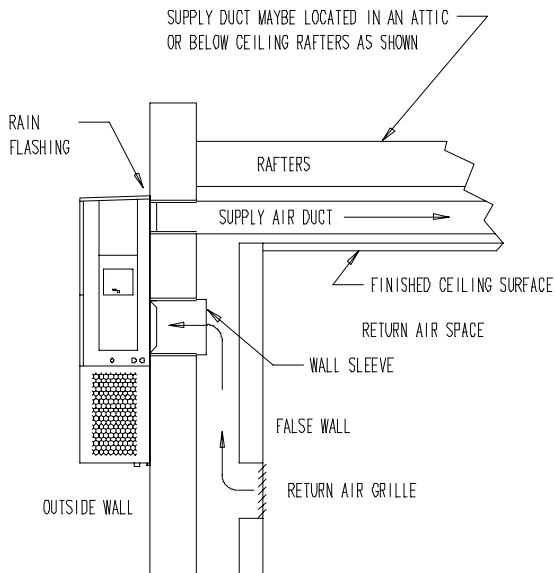

FALSE WALL INSTALLATION

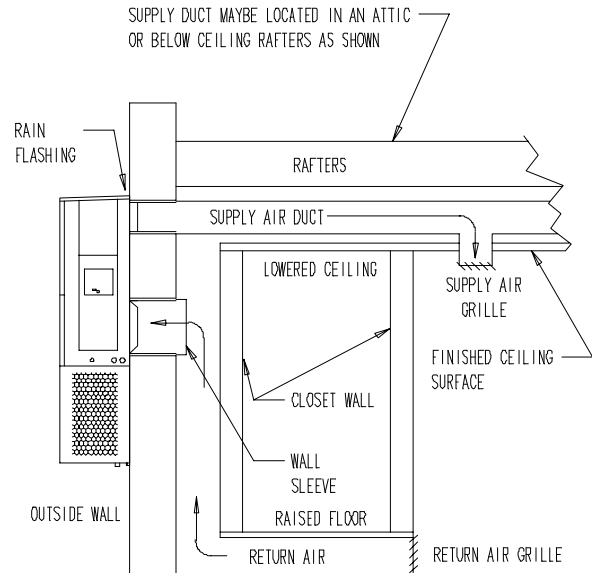

CLOSET INSTALLATION

MIS-550

FIGURE 7 — ELECTRIC HEAT CLEARANCE

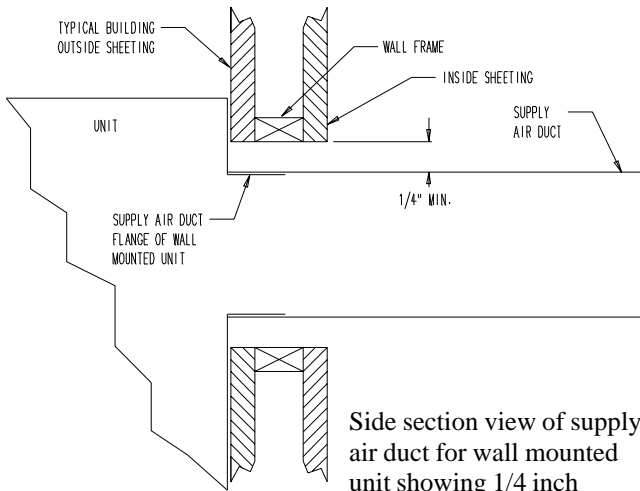

MIS-277

Side section view of supply air duct for wall mounted unit showing 1/4 inch clearance to combustible surfaces.

WARNING

- A minimum of 1/4 inch clearance must be maintained between the supply air duct and combustible materials. This is required for the first 3 feet of ducting.
- It is important to insure that the 1/4 inch minimum spacing is maintained at all points.
- Failure to do this could result in overheating the combustible material and may result in fire.

**FIGURE 8
LOW VOLTAGE WIRING**

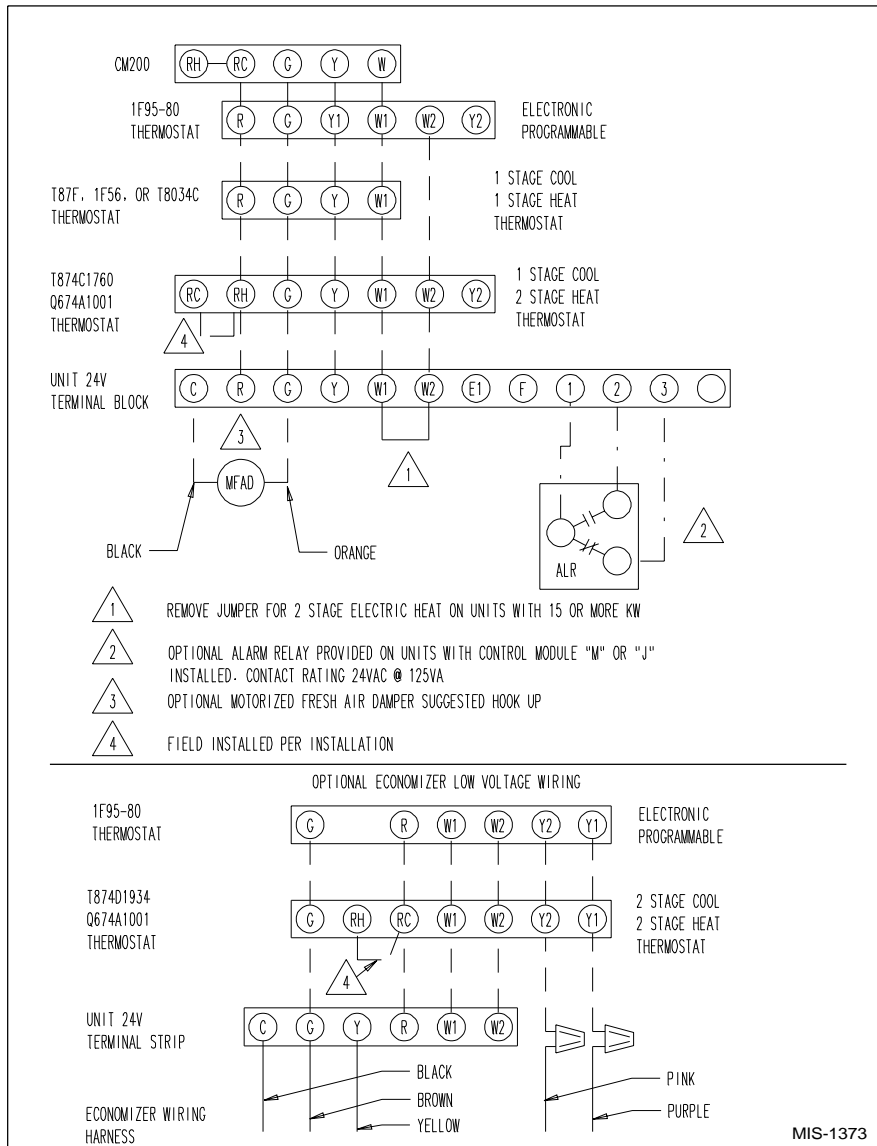

MIS-1373

START UP

IMPORTANT INSTALLER NOTE

For improved start-up performance, wash the indoor coil with a dishwasher detergent.

CRANKCASE HEATERS

All units are provided with some form of compressor crankcase heat.

All single and three phase models have an insertion well-type heater located in the lower section of the compressor housing. This is a self-regulating type heater that draws only enough power to maintain the compressor at a safe temperature.

Some form of crankcase heat is essential to prevent liquid refrigerant from migrating to the compressor, causing oil pump out on compressor start up and possible valve failure due to compressing a liquid.

The decal in Figure 9 is affixed to all outdoor units detailing start up procedure. This is very important. Please read carefully.

SERVICE HINTS

1. Caution homeowner to maintain clean air filters at all times. Also, not to needlessly close off supply and return air registers. This reduces air flow through the system, which shortens equipment service life as well as increasing operating costs.
2. Check all power fuses or circuit breakers to be sure they are the correct rating.
3. Periodic cleaning of the outdoor coil to permit full and unrestricted airflow circulation is essential.

SEQUENCE OF OPERATION

Cooling—Circuit R-Y makes at thermostat pulling in compressor contactor, starting the compressor and outdoor motor. The G (indoor motor) circuit is automatically completed on any call for cooling operation or can be energized by manual fan switch on subbase for constant air circulation. On all 230 volt units there is a one minute off delay on the blower motor. 460 volt models do not have an off delay. On a call for heating, circuit R-W1 make at the thermostat pulling in heat contact for the strip heat and blower operation. On a call for second stage heat, R-W2 makes bringing on second heat contactor, if so equipped.

COMPRESSOR CONTROL MODULE

The compressor control module is optional on the models covered by this manual. The compressor control is an anti-short cycle/lockout timer with high and low pressure switch monitoring and alarm relay output.

Adjustable Delay On Make And Break Timer

On initial power up or any time power is interrupted to the unit the *delay on make* period begins which will be 2 minutes plus 10% of the *delay on break* setting. When the delay on make is complete and the high pressure switch (and low pressure switch if employed) is closed, the compressor contactor is energized. Upon shutdown the delay or break timer starts and prevents restart until the delay on break and delay on make periods have expired.

During routine operation of the unit with no power interruptions the compressor will operate on demand with no delay.

High Pressure Switch and Lockout Sequence

If the high pressure switch opens, the compressor contactor will de-energize immediately. The lockout timer will go into a *soft lockout* and stay in soft lockout until the high pressure switch closes and the delay on break time has expired. If the high pressure switch opens again in this same operating cycle the unit will go into *manual lockout* condition and the alarm relay circuit will energize. Recycling the wall thermostat resets the manual lockout.

FIGURE 9
START UP LABEL

IMPORTANT

These procedures must be followed at initial start up and at any time power has been removed for 12 hours or longer.

To prevent compressor damage which may result from the presence of liquid refrigerant in the compressor crankcase:

1. Make certain the room thermostat is in the "off" position (the compressor is not to operate).
2. Apply power by closing the system disconnect switch. This energizes the compressor heater which evaporates the liquid refrigerant in the crankcase.
3. Allow 4 hours or 60 minutes per pound of refrigerant in the system as noted on the unit rating plate, whichever is greater.
4. After properly elapsed time, the thermostat may be set to operate the compressor.
5. Except as required for safety while servicing, **Do not open system disconnect switch.**

7961-061

Low Pressure Switch, Bypass, and Lockout Sequence

If the low pressure switch opens for more than 120 seconds, the compressor contactor will de-energize and go into a soft lockout. Regardless the state of the low pressure switch, the contactor will reenergize after the delay on make time delay has expired. If the low pressure switch remains open, or opens again for longer than 120 seconds the unit will go into manual lockout condition and the alarm relay circuit will energize. Recycling the wall thermostat resets the manual lockout.

Alarm Relay Output

Alarm terminal is output connection for applications where alarm relay is employed. This terminal is powered whenever compressor is locked out due to HPC or LPC sequences as described.

NOTE: Both high and low pressure switch controls are inherently automatic reset devices. The high pressure switch and low pressure switch cut out and cut in settings are fixed by specific air conditioner or heat pump unit model. The lockout features, both soft and manual, are a function of the Compressor Control Module.

ADJUSTMENTS

Adjustable Delay on Make and Delay on Break Timer

The potentiometer is used to select Delay on Break time from 30 seconds to 5 minutes. Delay on Make (DOM) timing on power-up and after power interruptions is equal to 2 minutes plus 10% of Delay on Break (DOB) setting:

0.5 minute (30 seconds)	DOB = 123 second	DOM
1.0 minute (60 seconds)	DOB = 126 second	DOM
2.0 minute (120 seconds)	DOB = 132 second	DOM
3.0 minute (180 seconds)	DOB = 138 second	DOM
4.0 minute (240 seconds)	DOB = 144 second	DOM
5.0 minute (300 seconds)	DOB = 150 second	DOM

During routine operation of the unit with no power interruptions the compressor will operate on demand with no delay.

Typical Settings for Dual Unit Installation:

Unit No. 1: DOB set at 2 minutes, and DOM is 132 seconds

Unit No. 2: DOB set at 4 minutes, and DOM is 144 seconds

PRESSURE SERVICE PORTS

High and low pressure service ports are installed on all units so that the system operating pressures can be observed. Pressure tables can be found later in the manual covering all models. It is imperative to match the correct pressure table to the unit by model number.

TROUBLESHOOTING

FAN BLADE SETTING DIMENSIONS

Shown in the drawing below are the correct fan blade setting dimensions for proper air delivery across the outdoor coil.

Any service work requiring removal or adjustment in the fan and/or motor area will require that the dimensions below be checked and blade adjusted in or out on the motor shaft accordingly.

**FIGURE 10
FAN BLADE SETTING**

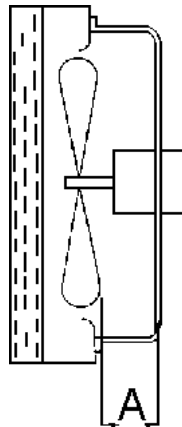

**TABLE 7
FAN BLADE DIMENSION**

Model	Dimension A
WA301 WA361	1.25

REMOVAL OF FAN SHROUD

1. Disconnect all power to unit.
2. Remove the screws holding both grills, one on each side of unit, and remove grills.
3. Remove screws holding fan shroud to condenser and bottom – 9 screws.
4. Unwire condenser fan motor.
5. Slide complete motor, fan blade, and shroud assembly out the left side of the unit.
6. Service motor/fan as needed.
7. Reverse steps to reinstall.

REFRIGERANT CHARGE

The correct system R-22 charge is shown on the unit rating plate. Optimum unit performance will occur with a refrigerant charge resulting in a suction line temperature (6 inches from compressor) as shown in Table 8.

**TABLE 8
SUCTION LINE TEMPERATURES**

Model	Rated Airflow	95 F OD Temperature	82 F OD Temperature
WA301	1,100	55 - 57	64 - 66
WA361	1,100	57 - 59	62 - 64

The suction line temperatures in Table 8 are based upon 80°F dry bulb/67°F wet bulb (50 percent R.H.) temperature and rated airflow across the evaporator during cooling cycle.

**TABLE 9
INDOOR BLOWER PERFORMANCE
CFM AT 230 VOLTS**

E.S.P. In H ₂ O	WA301, WA361			
	High Speed		Low Speed	
	Dry Coil	Wet Coil	Dry Coil	Wet Coil
.0	1,395	1,315	950	935
.1	1,340	1,270	930	915
.2	1,285	1,190	910	885
.3	1,205	1,100	855	830
.4	1,110	1,000	800	755
.5	1,005	870	---	---

**TABLE 11
MAXIMUM ESP OF OPERATION
ELECTRIC HEAT ONLY**

Model	Front Outlet		Top Outlet	
	Low Speed	High Speed	Low Speed	High Speed
A00	.50	.50	.50	.50
A05	.50	.50	.45	.50
A08	.50	.50	---	---
A10	.45	.50	.35	.50
A15	.35	.40	---	---
B00	.50	.50	.50	.50
B06	.40	.50	---	---
B09	.50	.50	.40	.45
B15	.30	.45	---	---
C00	.50	.50	.50	.50
C06	.50	.50	---	---
C09	.40	.50	.40	.45
C15	.35	.45	---	---

**TABLE 10
CFM and ESP**

Model	① Rated CFM	① Rated ESP	Recommended Airflow Range
WA301	1,000	.40	930 - 1,300
WA361	1,100	.30	930 - 1,350

① Rated CFM and ESP on high speed tap

**TABLE 12
COOLING PRESSURE – OUTDOOR TEMPERATURE °F**

Model	Return Air Temperature	Pressure	75	80	85	90	95	100	105	110	115	120	125
WA301	75 deg DB 62 deg WB	Low Side	74	77	79	81	82	84	85	85	86	87	88
		High Side	218	232	247	262	277	292	306	325	341	357	373
	80 deg DB 67 deg WB	Low Side	80	82	84	86	88	89	91	91	92	93	94
		High Side	223	238	253	268	284	300	316	333	350	366	383
	85 deg DB 72 deg WB	Low Side	85	88	91	93	95	96	97	96	99	100	101
		High Side	231	246	262	278	294	310	327	345	362	379	396
WA361	75 deg DB 62 deg WB	Low Side	70	72	74	76	78	79	80	81	82	83	84
		High Side	224	242	259	275	290	304	316	328	339	351	363
	80 deg DB 67 deg WB	Low Side	75	77	79	81	83	85	86	87	88	89	90
		High Side	229	248	265	272	297	311	325	337	348	360	373
	85 deg DB 72 deg WB	Low Side	80	83	85	87	89	91	92	94	95	96	98
		High Side	238	257	275	292	307	322	336	349	360	373	386

Low side pressure ± 2 psig

High side pressure ± 5 psig

Tables are based upon rated CFM (airflow) across the evaporator coil and should be found under section titled "refrigerant charge" elsewhere in manual. If there is any doubt as to correct charge being in the system, the charge should be removed, system evacuated and recharged to serial plate instructions.

**TABLE 13
OPTIONAL ACCESSORIES**

MODEL	DESCRIPTION	WA301-A	WA301-B	WA301-C	WA361-A	WA361-B	WA361-C
EHWA03-A05	Heater Packages ①	X			X		
EHWA03-A08	Heater Packages ①	X			X		
EHWA03-A10	Heater Packages ①	X			X		
EHWA03-A15	Heater Packages ①	X			X		
EHWA03-B06	Heater Packages ①		X			X	
EHWA03-B09	Heater Packages ①		X			X	
EHWA03-B15	Heater Packages ①		X			X	
EHWA03-C06	Heater Packages ①			X			X
EHWA03-C09	Heater Packages ①			X			X
EHWA03-C12	Heater Packages ①						X
EHWA03-C15	Heater Packages ①			X			X
BOP-3	Blank Off Plate	X	X	X	X	X	X
BFAD-3	Barometric Fresh Air Damper	X	X	X	X	X	X
MFAD-3	Motorized Fresh Air Damper	X	X	X	X	X	X
CRV-3	Commercial Ventilator with Exhaust	X	X	X	X	X	X
EIFM-3	Economizer with Exhaust	X	X	X	X	X	X
WERV-A3B	Energy Recovery Ventilator	X	X		X	X	
WERV-C3B	Energy Recovery Ventilator			X			X
CMA-5	Time Delay Relay (TDR)	X	X	X	X	X	X
CMA-6	Low Ambient Control	X	X		X	X	
CMA-8	TDR + HPC	X	X	X	X	X	X
CMA-10	LPC + HPC + TDR	X	X	X	X	X	X
CMA-13	LPC + HPC + TDR + LAC	X	X		X	X	
CMC-15	Start Kit	X			X		
WMCB-05A	Circuit Breaker Kit	X			X		
WMCB-02B	Circuit Breaker Kit		X				
WMPD-01C	Pull Disconnect Kit			X			X
WMCB-03B	Circuit Breaker Kit					X	