

INSTALLATION INSTRUCTIONS

WALL MOUNTED PACKAGE HEAT PUMPS

MODELS

WH181

WH241

MANUAL 2100-201 REV. A
SUPERSEDES REV.
FILE VOL. III, TAB 17

COPYRIGHT MARCH, 1992
BARD MANUFACTURING COMPANY
BRYAN, OHIO

TABLE OF CONTENTS

Important	3
Shipping Damage	3
General	3
Installation	3
Duct Work	3
Filter	3
Fresh Air Intake	4
Wall Mounting	4
Mounting Instructions	4
Wiring--Main Power	6
Transformers	6
Wiring--24V Control Circuit	6
Condensate Drain	7
Compressor Malfunction Light (Single Phase Models Only)	7
Pressure Service Ports	7
Sequence of Operation	7
Compressor Cut-Off Thermostat and Outdoor Thermostats	7
Compressor Cut-Off and Outdoor Thermostat Wiring	7
Heat Anticipation	8
Thermostat Indicator Lamps	8
Emergency Heat Position	8
Defrost Cycle	9
Solid State Heat Pump Control Troubleshooting Procedure	10
Checking Temperature Sensor Outside Unit Circuit	11
Service Hints	12
Important Installer Note	12
Crankcase Heaters	12
Fan Blade Setting Dimensions	13
Refrigerant Charge	13
Pressure Curves	15
Optional Accessories	16

FIGURES AND TABLES

Figure 1	1
Figure 2	5
Figure 4	9
Figure 5	12
Figure 6	13
Table 1	2
Table 2	6
Table 3	8
Table 4	10
Table 5	13
Table 6	13
Table 7	14
Table 8	14
Table 9	14
Table 10	15
Table 11	15
Table 12	16

FIGURE 7

SIZE SPECS FOR MIS-278

UNIT	WIDTH (W)	DEPTH (D)	HEIGHT (H)	SUPPLY		RETURN		E	F	G	I	J	K	L	M	N	O
				A	B	C	B										
18 & 24	32-7/8	16-7/8	70	7-7/8	20	11-7/8	20	34-7/8	18-1/4	25-3/4	20-3/4	26-3/4	28-3/4	29-1/4	27	2-9/16	34

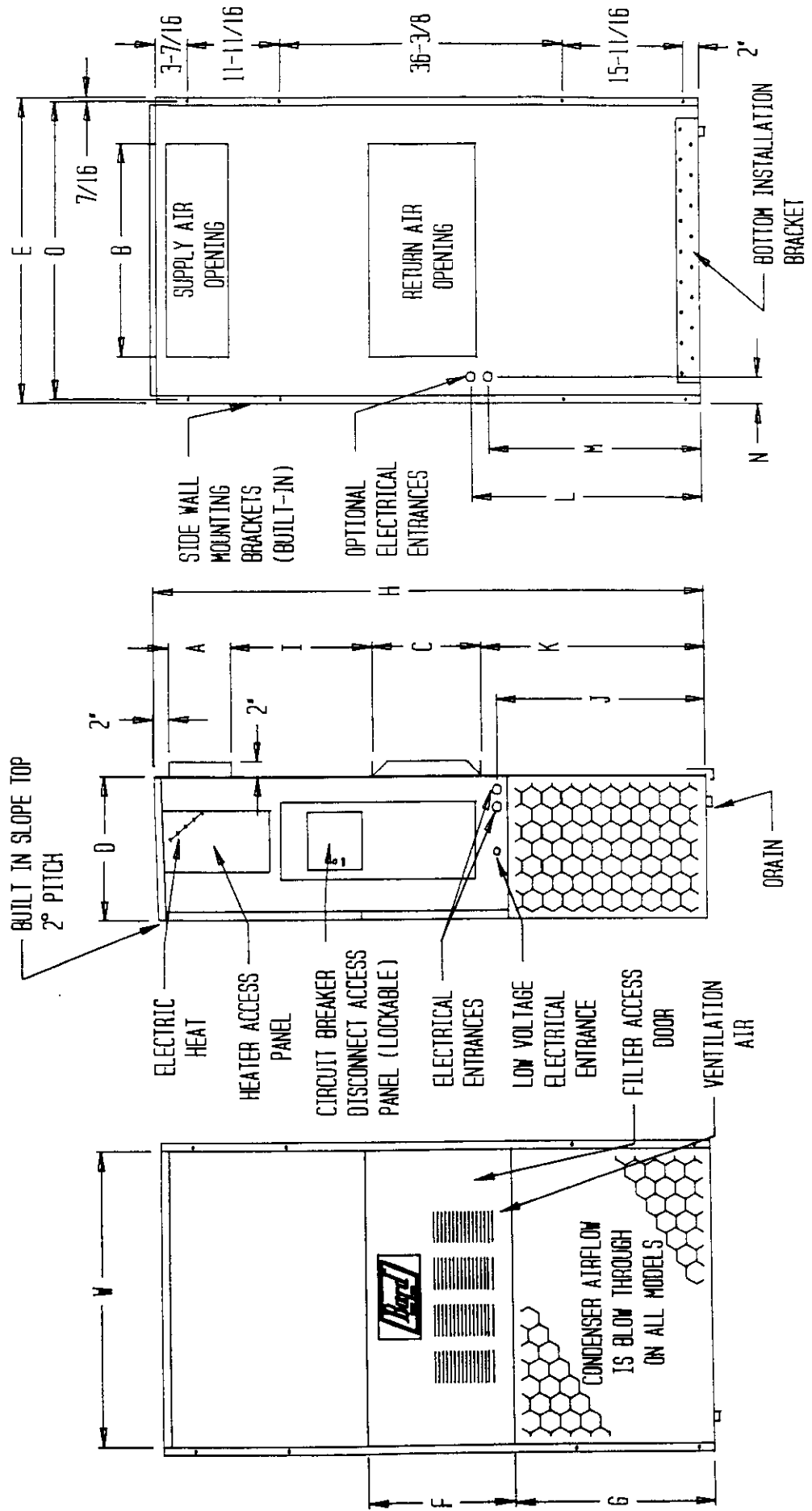

FRONT VIEW

SIDE VIEW

BACK VIEW

ELECTRICAL SPECIFICATIONS

TABLE 1

SINGLE CIRCUIT						
Model	Rated Volts and Phase	No. Field Power Ckts.	Minimum Circuit Ampacity	(1) Maximum External Fuse Or Circuit Breaker	(2) Field Power Wire Size	(2) Ground Wire Size
WH181-A00		1	15	20	12	12
A04	230/208-1	1	36	40	10	10
(3) A08		1	57	60	6	10
WH241-A00		1	16	25	12	12
A04	230/208-1	1	37	40	10	10
(3) A08		1 or 2	58	60	6	10
WH241-B00		1	13	20	12	12
B06	230/208-3	1	31	35	8	10
WH241-C00		1	8	15	14	14
C06	460-3	1	17	20	12	12

(1) Maximum size of the time delay fuse or HACR type circuit breaker for protection of field wiring conductors.

(2) Based on 75°C copper wire.

(3) Maximum KW that can operate with heat pump on.

(4) All wiring must conform to NEC and all local codes.

IMPORTANT

The equipment covered in this manual is to be installed by trained, experienced service and installation technicians. Any heat pump is more critical of proper operating, charge and an adequate duct system than a straight air conditioning unit. All duct work, supply and return, must be properly sized for the design air flow requirement of the equipment. ACCA is an excellent guide to proper sizing. All duct work or portions thereof not in the conditioned space should be properly insulated in order to both conserve energy and prevent condensation or moisture damage.

SHIPPING DAMAGE

Upon receipt of equipment, the carton should be checked for external signs of shipping damage. If damage is found, the receiving party must contact the last carrier immediately, preferably in writing, requesting inspection by the carrier's agent.

GENERAL

The refrigerant system is completely assembled and charged. All internal wiring is complete.

The unit is designed for use with or without duct work. Flanges are provided for attaching the supply and return ducts.

These instructions explain the recommended method to install the air cooled self-contained unit and the electrical wiring connections to the unit.

These instructions and any instructions packaged with any separate equipment required to make up the entire air conditioning system should be carefully read before beginning the installation. Note particularly "Starting Procedure" and any tags and/or labels attached to the equipment.

While these instructions are intended as a general recommended guide, they do not supersede any national and/or local codes in any way. Authorities having jurisdiction should be consulted before the installation is made.

INSTALLATION

Size of unit for a proposed installation should be based on heat loss calculation made according to methods of Air Conditioning Contractors of America (ACCA). The air duct should be installed in accordance with the Standards of the National Fire Protection Association for the Installation of Air Conditioning and Ventilating systems of Other Than Residence Type, NEPA No. 90A, and Residence Type Warm Air Heating and Air Conditioning Systems, NEPA No. 90B. Where local regulations are at a variance with instructions, installer should adhere to local codes.

DUCT WORK

Design the duct work according to methods given by the Air Conditioning Contractors of America. When duct runs through unheated spaces, it should be insulated with a minimum of one inch of insulation. Use insulation with a vapor barrier on the outside of the insulation. Flexible joints should be used to connect the duct work to the equipment in order to keep the noise transmission to a minimum.

FILTER

A 1-throwaway filter is supplied with each unit. The filter slides into position making it easy to service. This filter can be serviced from the outside by removing the service door. A 1-inch washable filter and 2-inch pleated filter are also available as optional accessories. The internal filter brackets are adjustable to accommodate the 2-inch filter.

FRESH AIR INTAKE

All units are built with a fresh air inlet slots punched in the service panel.

The fresh air damper assembly is standard equipment with the unit because of the variety of state or local codes requiring fresh air capability. It is shipped already attached to each unit.

All capacity, efficiency and cost of operation information as required for Department of Energy "Energyguide" Fact Sheets is based upon the fresh air blank-off plate in place and is recommended for maximum energy efficiency.

The blank-off plate is available upon request from the factory and is installed in place of the fresh air damper shipped with each unit.

WALL MOUNTING

1. Two holes, for the supply and return air openings, must be cut through the wall as shown in Figure 2.
2. On wood-frame walls, the wall construction must be strong and rigid enough to carry the weight of the unit without transmitting any unit vibration. **WARNING:** Fire hazard can result if 1/4-inch clearance to combustible materials for supply air duct is not maintained. See Figure 2.
3. Concrete block walls must be thoroughly inspected to insure that they are capable of carrying the weight of the installing unit.
4. Ducts through the walls must be insulated and all joints taped or sealed to prevent air or moisture entering the wall cavity.
5. Some installations may not require any return air duct. It is recommended that on this type of installation that a filter grille be located in the wall. Filters must be of sufficient size to allow a maximum velocity of 400 FPM.

NOTE: If no return air duct is used, applicable installation codes may limit this cabinet to installation only in a single story structure.

MOUNTING INSTRUCTIONS

1. These units are secured by wall mounting brackets which secure the unit to the outside wall surface at both sides. A bottom mounting brackets is provided for ease of installation, but are not required.
2. Locate and mark lag bolt locations and bottom mounting bracket location, if desired. See Figure 2.
3. Mount bottom mounting bracket, if used.
4. Position unit in opening and secure with 5/16 lag bolts; use flat washers on the lag bolts.
5. For additional mounting rigidity, the return air and supply air (depending upon wall construction) frames or collars can be drilled and screwed or welded to the structural wall itself.
6. Maintain 30 inches minimum clearance on right side of unit to allow access to heat strip.

FIGURE 2

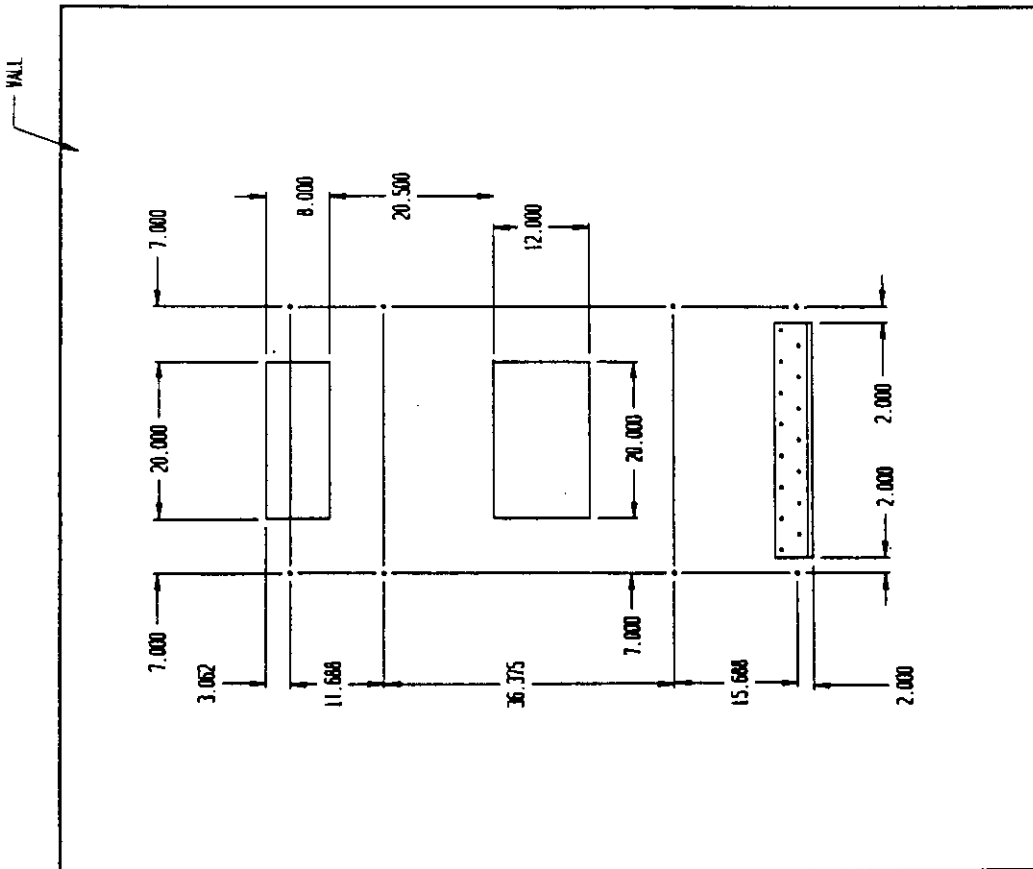
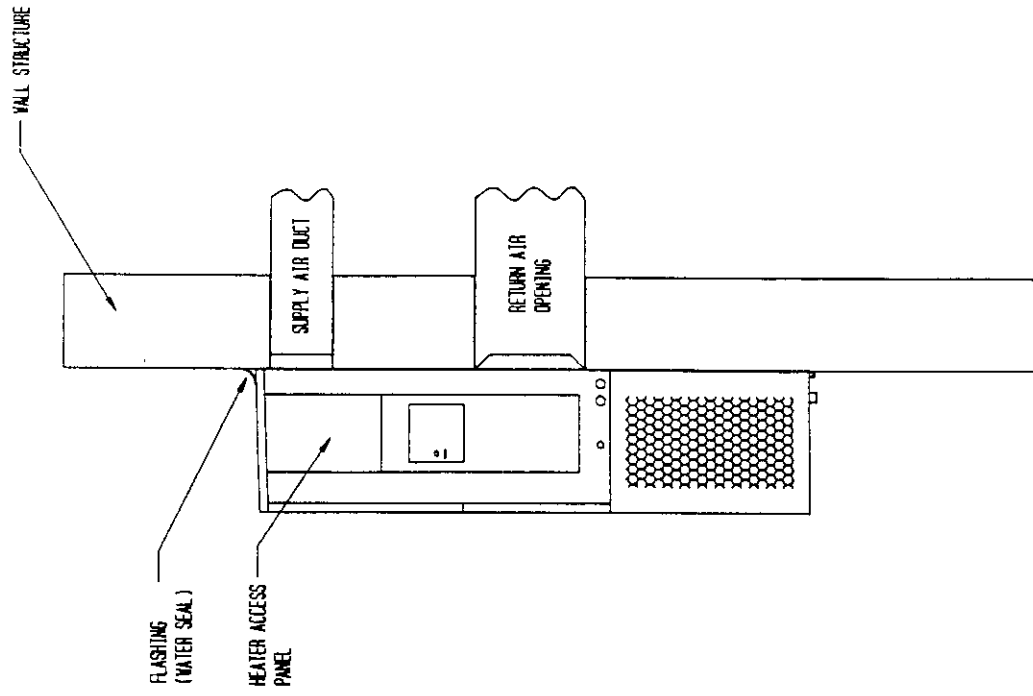

WIRING--MAIN POWER

Refer to the unit rating plate for wire sizing information and maximum fuse or "HACR Type" circuit breaker size. Each outdoor unit is marked with a "Minimum Circuit Ampacity". This means that the field wiring used must be sized to carry that amount of current. Depending on the installed KW of electric heat, there may be two field power circuits required. If this is the case, the unit serial plate will so indicate. All models are suitable only for connection with copper wire. Each unit and/or wiring diagram will be marked "Use Copper Conductors Only". These instructions MUST BE adhered to. Refer to the National Electrical Code for complete current carrying capacity data on the various insulation grades of wiring material.

The electrical data lists fuse and wire sizes (75°C copper) for all models, including the most commonly used heater sizes. Also shown are the number of field power circuits required for the various models with heaters.

The unit rating plate lists a "Maximum Time Delay Relay Fuse" or "HACR Type" circuit breaker that is to be used with the equipment. The correct size must be used for proper circuit protection and also to assure that there will be no nuisance tripping due to the momentary high starting current of the compressor motor.

TRANSFORMERS

230/208V, 1 phase and 3 phase equipment dual primary voltage transformers. All equipment leaves the factory wired on 240V tap. For 208V operation, reconnect from 240V to 208V tap. The acceptable operating voltage range for the 240 and 208V taps are:

TAP	RANGE
240	253 - 216
208	220 - 187

NOTE: The voltage should be measured at the field power connection point in the unit and while the unit is operating at full load (maximum amperage operating condition).

WIRING--24V CONTROL CIRCUIT

Nine (9) wires should be run from thermostat subbase to the 24V terminal board in the unit. A nine conductor, 18 gauge copper, color-coded thermostat cable is recommended. The connection points are shown below:

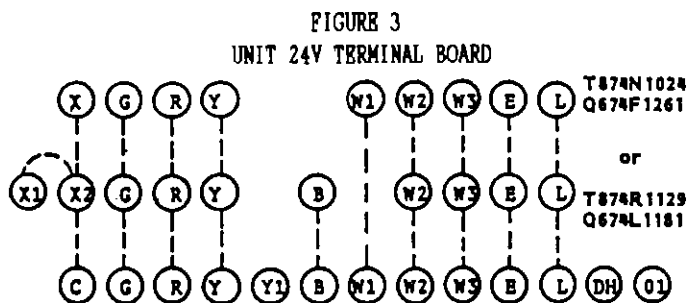

IMPORTANT NOTE: Only the thermostat and subbase combinations as shown above will work with this equipment. The thermostat and subbase MUST be matched, and the correct operation can be assured only by proper selection and application of these parts.

TABLE 2

Transformer VA	FLA	Wire Gauge	Maximum Distance
			In Feet
55	2.3	20 Gauge	45
		18 "	60
		16 "	100
		14 "	160
		12 "	250

CONDENSATE DRAIN

A plastic drain hose extends from the drain pan at the top of the unit down to the unit base. There are openings in the unit base for the drain hose to pass through. In the event the drain hose is connected to a drain system of some type, it must be an open or vented type system to assure proper drainage.

COMPRESSOR MALFUNCTION LIGHT (Single Phase Models Only)

Actuation of the green "check" lamp is accomplished by a relay output from the heat pump control board which is factory installed. Any condition such as loss of charge, defective capacitor, defective contactor, etc., that will prevent compressor from operating will cause green lamp to activate. This is a signal to the operator of the equipment to place system in emergency heat position.

PRESSURE SERVICE PORTS

High and low pressure service ports are installed on all units so that the system operating pressures can be observed. Pressure curves can be found later in the manual covering all models on both cooling and heating cycles. It is imperative to match the correct pressure curve to the unit by model number.

SEQUENCE OF OPERATION

COOLING--Circuit R-Y makes at thermostat pulling in compressor contactor, starting the compressor and outdoor motor. The G (indoor motor) circuit is automatically completed on any call for cooling operation or can be energized by manual fan switch on subbase for constant air circulation.

HEATING--A 24V solenoid coil on reversing valve controls heating cycle operation. Two thermostat options, one allowing "Auto" changeover from cycle to cycle and the other constantly energizing solenoid coil during heating season and thus eliminating pressure equalization noise except during defrost, are to be used. On "Auto" option, a circuit is completed from R-W1 and R-Y on each heating "on" cycle, energizing reversing valve solenoid and pulling in compressor contactor starting compressor and outdoor motor. R-G also make starting indoor blower motor. Heat Pump heating cycle now in operation. The second option has no "Auto" changeover position, but instead energizes the reversing valve solenoid constantly whenever the system switch on subbase is placed in "Heat" position, the "B" terminal being constantly energized from R. A thermostat demand for heat completes R-Y circuit, pulling in compressor contactor starting compressor and outdoor motor. R-G also make starting indoor blower motor.

COMPRESSOR CUT-OFF THERMOSTAT AND OUTDOOR THERMOSTATS

Heat pump compressor operation at outdoor temperatures below 0°F are neither desirable nor advantageous in terms of efficiency. Since most equipment at time of manufacture is not designated for any specific destination of the country and most of the equipment is installed in areas not approaching the lower outdoor temperature range, the compressor cut-offs are not factory installed.

Outdoor thermostats are available to hold off various banks of electric heat until needed as determined by outdoor temperature. The set point of either type of thermostat is variable with geographic region and sizing of the heating equipment to the structure. Utilization of the Heating Application Data and the heat loss calculation of the building are useful in determining the correct set points.

HEAT ANTICIPATION

Both of the thermostats shown below have a fixed heat anticipator for stage 1 with no adjustment required. Stage 2 has an adjustable anticipator for the W2 connection and fixed for the W3 connection. Both the W2 and W3 circuits are controlled by the stage 2 bulb. The only heat anticipator that needs to be checked is stage 2 and it should be set to match the load carried by the W2 circuit. The normal factory wiring provides for only one electric heat contactor to be controlled by W2, and the anticipator should be set at .40A. If special field wiring is done, it is best to actually measure the load but a good rule is .40A for EACH heat contactor controlled by W2.

TABLE 3

WALL THERMOSTAT AND SUBBASE COMBINATIONS			
Group	Thermostat	Subbase	Predominant Features
A	8403-017 (T874R1129)	8404-009 (O674L1181)	Heat or Cool (1) No Auto
B	8403-018 (T874N1024)	8404-010 (O674F1261)	Automatic Heat-Cool (2) Changeover Position

- (1) No automatic changeover position--must manually place in heat or cool. Reversing valve remains energized at all times system switch is in heat position (except during defrost cycle). No pressure equalization noise when thermostat is satisfied on either heating or cooling.
- (2) Allows thermostat to control both heating and cooling operation when set in "Auto" position. Reversing valve de-energizes at end of each "On" heating cycle.

IMPORTANT NOTE: Both thermostat and subbase combinations shown above incorporate the following features: Man-Auto fan switch, Off-Heat-Cool-Em. Heat Switch, and two (2) indicator lamps--one for emergency heat and one for compressor malfunction.

THERMOSTAT INDICATOR LAMPS

The red lamp marked "Em.Ht." comes on and stays on whenever the system switch is placed in the emergency heat position. The green lamp marked "check" will come on if there is any problem that prevents the compressor from running when it is supposed to be.

EMERGENCY HEAT POSITION

The operator of the equipment must manually place the system switch in this position. This is done when there is a known problem with the unit, or when the green "check" lamp comes on indicating a problem.

DEFROST CYCLE

The defrost cycle is controlled by temperature and time on the solid state heat pump control.

When the outdoor temperature is in the lower 40°F temperature range or colder, the outdoor coil temperature is 32°F or below. This coil temperature is sensed by the coil sensor mounted near the bottom of the outdoor coil. Once coil temperature reaches 30°F or below, the coil sends a signal to the control logic of the heat pump control and the defrost timer will start.

After 60 (90 or 30) minutes at 30°F or below, the heat pump control will place the system in the defrost mode.

During the defrost mode, the refrigerant cycle switches back to the cooling cycle, the outdoor motor stops, electric heaters are energized, and hot gas passing through the outdoor coil melts any accumulator frost. When the temperature rises to approximately 57°F, the coil sensor will send a signal to the heat pump control which will return the system to heating operations automatically.

If some abnormal or temporary condition such as a high wind causes the heat pump to have a prolonged defrost cycle, the heat pump control will restore the system to heating operation automatically after 10 minutes.

There are three settings on the heat pump control--30 minute, 60 minute, and 90 minute. Most models are shipped wired on the 60 minute setting for greatest operating economy. If special circumstances require a change to another time, remove wire connected to terminal 60 and reconnect to desired terminal.

There is a cycle speed up jumper on the control. This can be used to reduce the time between defrost cycle operation without waiting for time to elapse.

There is an initial defrost (sen jmp) jumper on the control that can be used at any outdoor ambient during the heating cycle to simulate a 0° coil temperature. This can be used to check defrost operation of the unit without waiting for the outdoor ambient to fall into the defrost region.

FIGURE 4

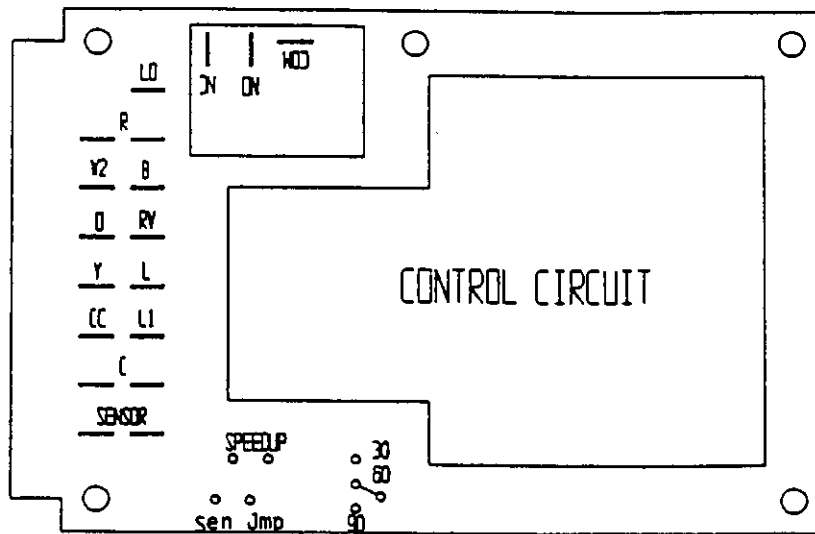

SOLID STATE HEAT PUMP CONTROL TROUBLESHOOTING PROCEDURE

1. Turn on AC power supply to indoor and outdoor units.
2. Turn thermostat blower switch to fan on--the indoor blower should start. (If it doesn't, troubleshoot indoor unit and correct problem).
3. Turn thermostat blower switch to auto position. Indoor blower should stop.
4. Set system switch to heat or cool. Adjust thermostat to call for heat or cool--The indoor blower, compressor, and outdoor fan should start.

NOTE: If there was no power to 24 volt transformer, the compressor and outdoor fan motor will not start for 5 minutes. This is because of the compressor short cycle protection.

TABLE 4

Symptom	Possible Causes	What to Check	How To Check Or Repair
Compressor contactor does not energize (cooling or heating)	Control circuit wiring	Check for R connection at unit, and 24V between R-C.	Run R connection to outdoor unit to power heat pump control.
	Compressor lock out	1. Check for 24V between L1-C on heat pump control. 2. Check across high pressure switch.	1. If no voltage between L1-C turn thermostat off and on again to reset high pressure switch. 2. If high pressure switch is open and will not reset, replace high pressure switch.
	Compressor short cycle protection	Check for 24V between CC-C and Y-C on heat pump control.	1. If no voltage between CC-C jumper speed up terminal and within 10 seconds power should appear between CC-C. Remove speed up jumper after 10 seconds.
	Heat pump control defective	Check all other possible causes. Manual 2100-065	Replace heat pump control.
	Contactor defective	Check for open or shorted coil winding.	Replace contactor.
Fan outdoor motor does not run (cooling or heating except during defrost)	Motor defective	Check for open or shorted motor winding	Replace motor.
	Motor capacitor defective	Check capacitor rating. Check for open or shorted capacitor.	Replace capacitor.
	Heat pump control defective	Check across fan relay on heat pump control. (Con-NC)	Replace heat pump control.
Reversing valve does not energize (heating only)	Reversing valve solenoid coil defective	Check for open or shorted coil.	Replace solenoid coil.
	Heat pump control defective	Check for 24V between RV-C and B-C.	1. Check control circuit wiring. 2. Replace heat pump control.
Unit will not go into defrost (heating only)	Temperature sensor or heat pump control defective	Disconnect temperature sensor from board and jumper across speed up terminals and sen jmp terminals. This should cause the unit to go through a defrost cycle within one minute.	1. If unit goes through defrost cycle, replace temperature sensor. 2. If unit does not go through defrost cycle, replace heat pump control.
Unit will not come out of defrost (heating only)	Temperature sensor or heat pump control defective	Jumper across speed up terminals. This should cause the unit to come out of defrost within one minute.	1. If unit comes out of defrost cycle, replace temperature sensor. 2. If unit does not come out of defrost cycle, replace heat pump control.

CHECKING TEMPERATURE SENSOR OUTSIDE UNIT CIRCUIT

1. Disconnect temperature sensor from board and from outdoor coil.
2. Use an ohmmeter and measure the resistance of the sensor. Also use ohmmeter to check for short or open.
3. Check resistance reading to chart of resistance use sensor ambient temperature. (Tolerance of part is $\pm 10\%$).
4. If sensor resistance reads very low, then sensor is shorted and will not allow proper operation of the heat pump control.
5. If sensor is out of tolerance, shorted, open, or reads very low ohms then it should be replaced.

TEMPERATURE F VS RESISTANCE R OF TEMPERATURE SENSOR

F	R	F	R	F	R
-25.0	196871	25.0	39898	75.0	10501
-24.0	190099	26.0	38757	76.0	10247
-23.0	183585	27.0	37652	77.0	10000
-22.0	177318	28.0	36583	78.0	9760
-21.0	171289	29.0	35548	79.0	9526
-20.0	165487	30.0	34545	80.0	9299
-19.0	159904	31.0	33574	81.0	9077
-18.0	154529	32.0	32634	82.0	8862
-17.0	149355	33.0	31723	83.0	8653
-16.0	144374	34.0	30840	84.0	8449
-15.0	139576	35.0	29986	85.0	8250
-14.0	134956	36.0	29157	86.0	8057
-13.0	130506	37.0	28355	87.0	7869
-12.0	126219	38.0	27577	88.0	7686
-11.0	122089	39.0	26823	89.0	7507
-10.0	118108	40.0	26092	90.0	7334
-9.0	114272	41.0	25383	91.0	7165
-8.0	110575	42.0	24696	92.0	7000
-7.0	107010	43.0	24030	93.0	6840
-6.0	103574	44.0	23384	94.0	6683
-5.0	100260	45.0	22758	95.0	6531
-4.0	97064	46.0	22150	96.0	6383
-3.0	93981	47.0	21561	97.0	6239
-2.0	91008	48.0	20989	98.0	6098
-1.0	88139	49.0	20435	99.0	5961
0.0	85371	50.0	19896	100.0	5827
1.0	82699	51.0	19374	101.0	5697
2.0	80121	52.0	18867	102.0	5570
3.0	77632	53.0	18375	103.0	5446
4.0	75230	54.0	17898	104.0	5326
5.0	72910	55.0	17434	105.0	5208
6.0	70670	56.0	16984	106.0	5094
7.0	68507	57.0	16547	107.0	4982
8.0	66418	58.0	16122	108.0	4873
9.0	64399	59.0	15710	109.0	4767
10.0	62449	60.0	15310	110.0	4663
11.0	60565	61.0	14921	111.0	4562
12.0	58745	62.0	14544	112.0	4464
13.0	56985	63.0	14177	113.0	4367
14.0	55284	64.0	13820	114.0	4274
15.0	53640	65.0	13474	115.0	4182
16.0	52051	66.0	13137	116.0	4093
17.0	50514	67.0	12810	117.0	4006
18.0	49028	68.0	12492	118.0	3921
19.0	47590	69.0	12183	119.0	3838
20.0	46200	70.0	11883	120.0	3757
21.0	44855	71.0	11591	121.0	3678
22.0	43554	72.0	11307	122.0	3601
23.0	42295	73.0	11031	123.0	3526
24.0	41077	74.0	10762	124.0	3452

SERVICE HINTS

1. Caution homeowner to maintain clean air filters at all times. Also, not to needlessly close off supply and return air registers. This reduces air flow through the system, which shortens equipment service life as well as increasing operating costs.
2. Switching to heating cycle at 75°F or higher outside temperature may cause a nuisance trip of the remote reset high pressure switch.
3. The heat pump wall thermostats perform multiple functions. Be sure that all function switches are correctly set for the desired operating mode before trying to diagnose any reported service problems.
4. Check all power fuses or circuit breakers to be sure they are the correct rating.
5. Periodic cleaning of the outdoor coil to permit full and unrestricted airflow circulation is essential.

IMPORTANT INSTALLER NOTE

For improved start-up performance, wash the indoor coil with a dishwasher detergent.

CRANKCASE HEATERS

All units are provided with some form of compressor crankcase heat.

All single and three phase models have an insertion well-type heater located in the lower section of the compressor housing. This is a self-regulating type heater that draws only enough power to maintain the compressor at a safe temperature.

Some form of crankcase heat is essential to prevent liquid refrigerant from migrating to the compressor, causing oil pump out on compressor start-up and possible valve failure due to compressing a liquid.

The decal in Figure 5 is affixed to all outdoor units detailing start-up procedure. This is very important. Please read carefully.

FIGURE 5

IMPORTANT

THESE PROCEDURES MUST BE FOLLOWED AT INITIAL START-UP AND AT ANY TIME POWER HAS BEEN REMOVED FOR 12 HOURS OR LONGER.

TO PREVENT COMPRESSOR DAMAGE WHICH MAY RESULT FROM THE PRESENCE OF LIQUID REFRIGERANT IN THE COMPRESSOR CRANKCASE

1. MAKE CERTAIN THE ROOM THERMOSTAT IS IN THE "OFF" POSITION. (THE COMPRESSOR IS NOT TO OPERATE).
2. APPLY POWER BY CLOSING THE SYSTEM DISCONNECT SWITCH. THIS ENERGIZES THE COMPRESSOR HEATER WHICH EVAPORATES THE LIQUID REFRIGERANT IN THE CRANKCASE.
3. ALLOW 4 HOURS OR 60 MINUTES PER POUND OF REFRIGERANT IN THE SYSTEM AS NOTED ON THE UNIT RATING PLATE, WHICHEVER IS GREATER.
4. AFTER PROPERLY ELAPSED TIME THE THERMOSTAT MAY BE SET TO OPERATE THE COMPRESSOR.
5. EXCEPT AS REQUIRED FOR SAFETY WHILE SERVICING — DO NOT OPEN SYSTEM DISCONNECT SWITCH.

7961-061

FAN BLADE SETTING DIMENSIONS

Shown in the drawing below are the correct fan blade setting dimensions for proper air delivery across the outdoor coil.

Any service work requiring removal or adjustment in the fan and/or motor area will require that the dimensions below be checked and blade adjusted in or out on the motor shaft accordingly.

FIGURE 6

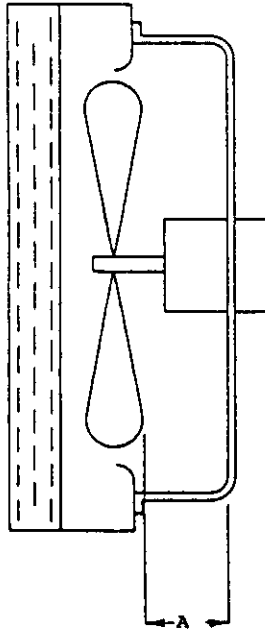

TABLE 5

Model	Dimension A
WH181	1.00
WH241	

REFRIGERANT CHARGE

The correct system R-22 charge is shown on the unit rating plate. Optimum unit performance will occur with a refrigerant charge resulting in a suction line temperature (6" from compressor) as shown in the following table:

TABLE 6

Model	Rated Airflow	° 95 F OD Temperature	° 82 F OD Temperature
WH181	650	56 - 58	63 - 65
WH241	800	57 - 59	65 - 67

The above suction line temperatures are based upon 80°F dry bulb/67°F wet bulb (50% R.H.) temperature and rated airflow across the evaporator during cooling cycle.

TABLE 7 INDOOR BLOWER PERFORMANCE--CFM @ 230V

E.S.P. In H ₂ O	WH181, WH241
	Dry / Wet
.0	1060 / 1015
.1	1000 / 840
.2	935 / 865
.3	855 / 765
.4	765 / 675
.5	640 / 555
.6	---

TABLE 8

Model	Rated CFM*	Rated ESP*	Recommended Airflow Range
WH181	650	.40	575 - 725
WH241	800	.20	700 - 950

*Rated CFM and ESP on high speed tap.

TABLE 9 MAXIMUM ESP OF OPERATION

Model	Low Speed	High Speed
WH181 A00	.50	.50
WH181 A04	.50	.50
WH241 A08	.35	.40
WH241 B00	.50	.50
WH241 B06	.50	.50
WH241 C00	.50	.50
WH241 C06	.50	.50

Values shown are for units equipped with STD 1" throw-away filter or 1" washable filter. Derate ESP by .15 for 2" pleated filters.

TABLE 10

COOLING

Air Temperature Entering Outdoor Coil °F

Model	Return Air Temperature	Pressure	°	°	°	°	°	°	°	°	°
			75	80	85	90	95	100	105	110	115
WH181	75 deg. DB	Low Side	77	78	80	81	83	84	86	87	89
	62 deg. WB	High Side	193	209	224	240	255	271	287	302	318
	80 deg. DB	Low Side	82	84	85	87	89	90	92	93	95
	67 deg. WB	High Side	198	214	230	246	262	278	294	310	326
WH241	85 deg. DB	Low Side	88	90	92	94	95	97	99	100	102
	72 deg. WB	High Side	205	222	238	255	271	288	304	321	337
	75 deg. DB	Low Side	75	76	77	79	80	81	83	84	86
	62 deg. WB	High Side	216	229	242	256	271	286	302	318	336
WH241	80 deg. DB	Low Side	80	81	83	84	85	87	88	90	92
	67 deg. WB	High Side	221	235	248	263	278	293	310	327	344
	85 deg. DB	Low Side	86	88	89	90	92	93	95	97	99
	72 deg. WB	High Side	229	243	257	272	288	304	321	338	356

TABLE 11

HEATING

Air Temperature Entering Outdoor Coil °F

Model	Return Air Temperature	Pressure	0	5	10	15	17	20	25	30	35	40	45	47	50	55	60
			WH181	70°	Low Side	20	24	27	31	32	35	39	44	49	54	59	62
High Side	178	181			184	189	191	194	201	208	216	225	235	239	246	257	270
WH241	70°	Low Side	30	30	31	32	33	34	37	41	45	50	56	59	63	71	79
		High Side	158	158	159	162	164	167	175	184	195	208	223	230	241	260	281

Low side pressure \pm 2 PSIGHigh side pressure \pm 5 PSIG

Tables are based upon rated CFM (airflow) across the evaporator coil and should be found under section titled "Refrigerant Charge" elsewhere in manual. If there is any doubt as to correct operating charge being in the system, the charge should be removed, system evacuated, and recharged to serial plate instructions.

TABLE 12

OPTIONAL ACCESSORIES

Model	Description	W	W	W	W
		H	H	H	H
		1	2	2	2
		8	4	4	4
		1	1	1	1
		-	-	-	-
		A	A	B	C
EHWB02-A05	Heater Packages	x	x		
EHWB02-A10	Heater Packages	x	x		
EHWB24-B06	Heater Packages			x	
EHWB24-C06	Heater Packages				x
BOP-2	Blank Off Plate	x	x	x	x
BFAD-2	Barometric Fresh Air Damper	x	x	x	x
MFAD-2	Motorized Fresh Air Damper	x	x	x	x
CRV-2	Classroom Ventilator With Exhaust	x	x	x	x
EIEM-2	Economizer With Exhaust	x	x	x	x
CMH-3	Low Pressure Control (LPC)	x	x	x	x
CMH-7	Low Ambient Control (LAC)	x	x	x	
CMH-9	LAC + LPC	x	x	x	
CMH-18	Outdoor Thermostat (ODT)	x	x		
CMH-19	LAC + LPC + ODT	x	x	x	
CMH-20	LPC + LAC + SK	x	x		
CMH-21	LPC + LAC + SK + ODT	x	x		
CMC-22	Start Skit (SK)	x	x		

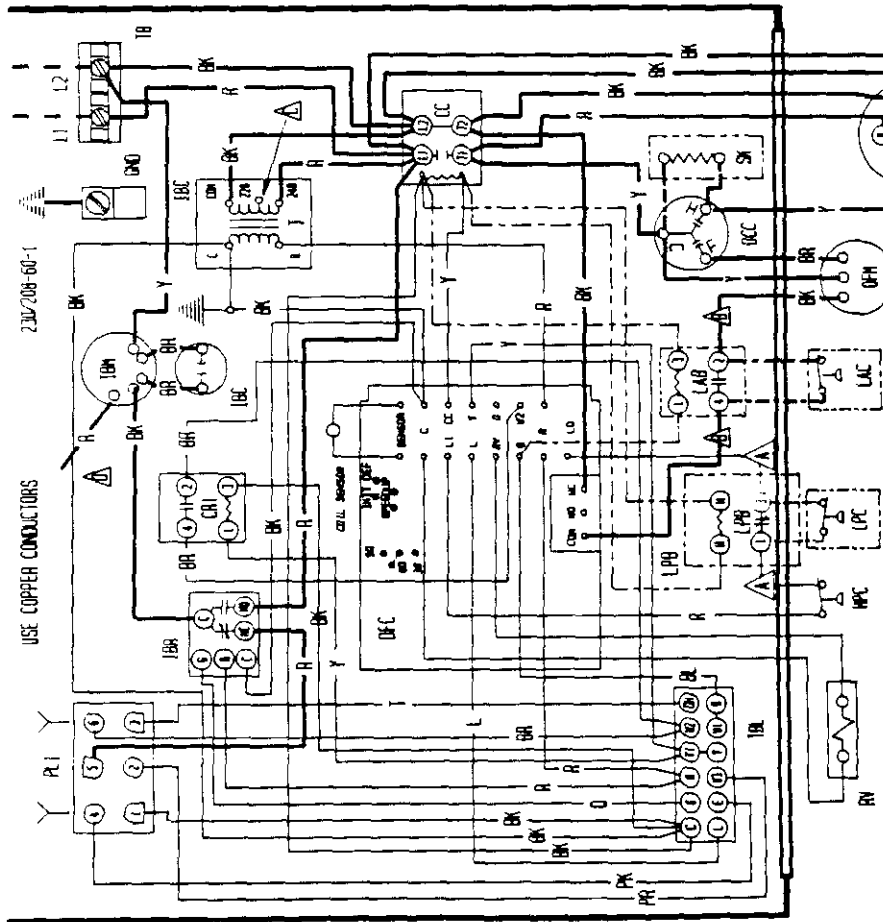
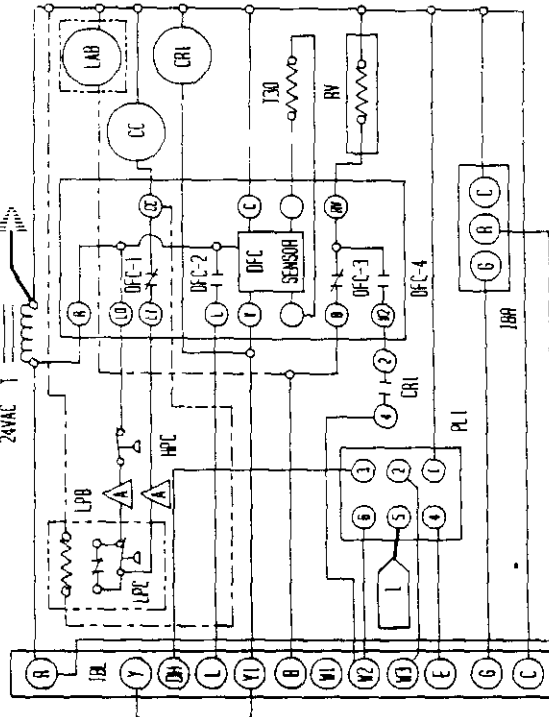
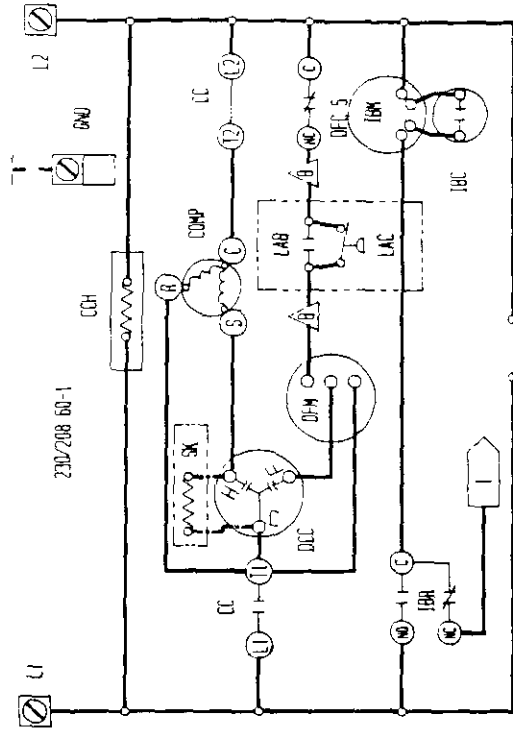

COMPONENT CODE	INDOOR BLOWER MOTOR
CB1	INDOOR BLOWER MOTOR
CB2	INDOOR BLOWER RELAY
CC	LOW AMBIENT BYPASS CONTROL
COH	LOW AMBIENT CONTROL
COMP	LOW PRESSURE BYPASS
CR1	LOW PRESSURE CONTROL
DCC	LIMIT SWITCH
DFC	OUTDOOR FAN MOTOR
DRH	PLUS #1
GRD	START KIT
R1	TRANSFORMER
R2	TERMINAL BLOCK
H1	LOW VOLTAGE TERMINAL BLOCK
H2	HEATER CONTACTOR #1
H3	HEATER CONTACTOR #2
HPC	HIGH PRESSURE CONTROL
IBC	INDOOR BLOWER CAPACITOR

▲ Labeled wires connect if no options used.

FACTORY STD.	FIGO	OPTIONAL
HIGH VOLTAGE		
LOW VOLTAGE		
ACCESSORY		

▲	▲	▲	▲
MOVE RED WIRE TO 208V TAP FOR 208V OPERATION	RED (LOW) BLACK (HIGH)	▲	▲

BLACK	BROWN	RED	ORANGE	Y	G	B	W	WHITE	V	Y	V	W	PINK	PA	L
0	1	2	3	4	5	6	7	8	9	10	11	12	13	14	15

Y	G	B	W	WHITE	V	Y	V	W	PINK	PA	L
16	17	18	19	20	21	22	23	24	25	26	27

BARO MFG. CO.
DWG 4095-110A
DATE 4-22-92
CHK/APPR [Signature]

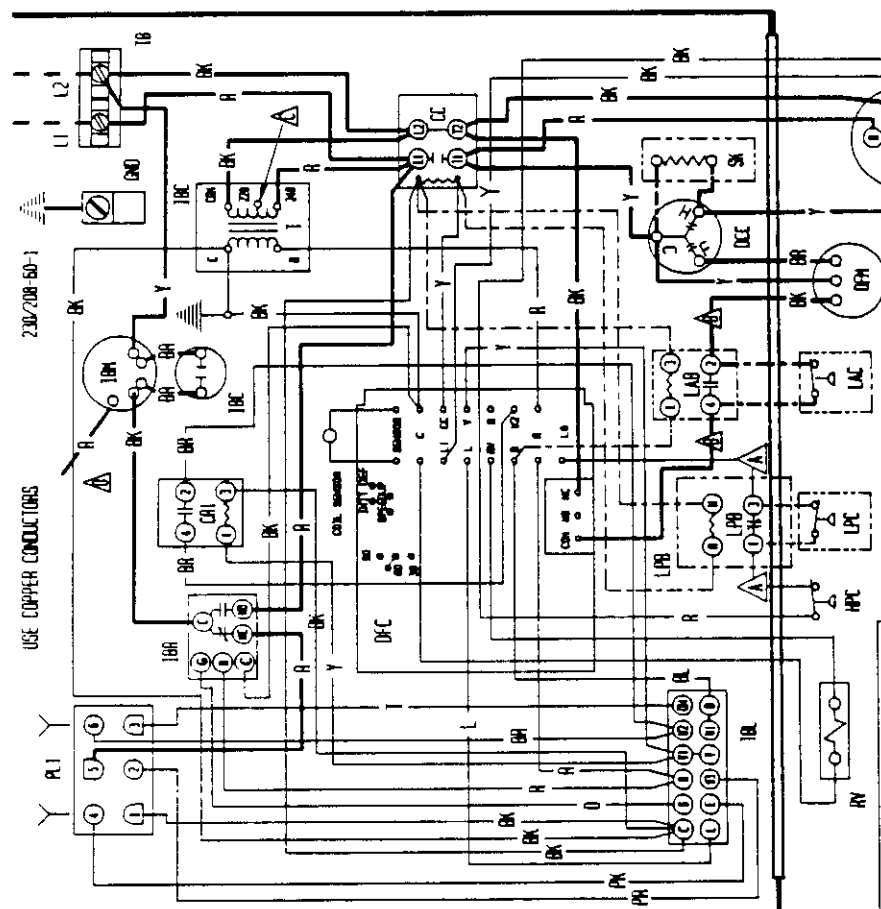
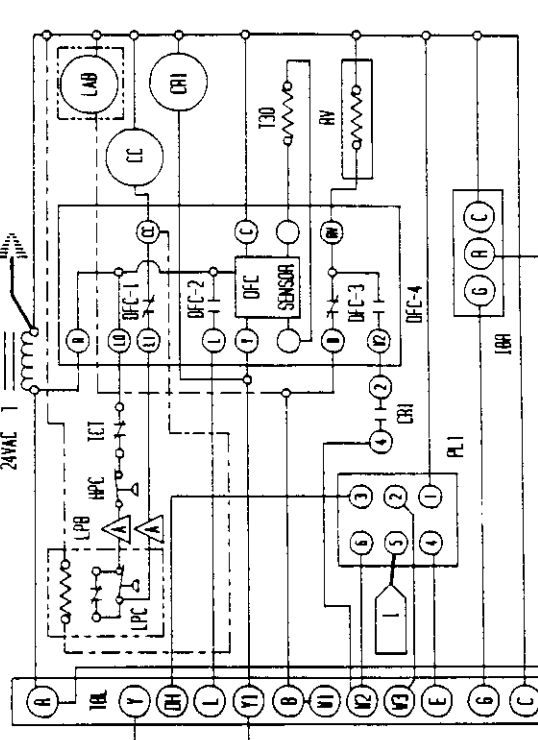
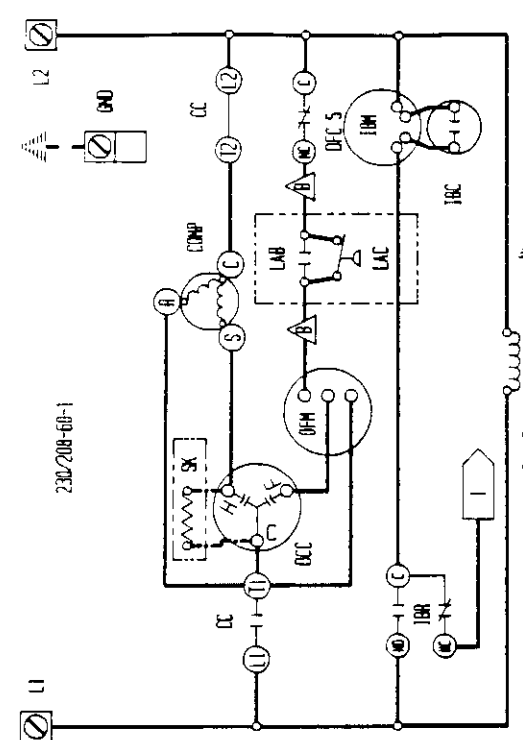

COMPONENT CODE	INDOOR BLOWER RELAY	LOW AMBIENT BYPASS CONTROL	LOW AMBIENT CONTROL	LOW PRESSURE BYPASS	LOW PRESSURE CONTROL	LIMIT SWITCH	OUTDOOR FAN MOTOR	PLUG #1	REY VALVE SOLINOID	START KIT	TOP CAP THERMOSTAT	TRANSFORMER	TERMINAL BLOCK	LOW VOLTAGE TERMINAL BLOCK	THERMAL CUTOFF
CB1	IBR	LAB	LAC	LPR	LPC	LS	OFM	PL1	RV	SK	TC1	T	IB	TBL	TCD

COMPONENT CODE	INDOOR BLOWER RELAY	LOW AMBIENT BYPASS CONTROL	LOW AMBIENT CONTROL	LOW PRESSURE BYPASS	LOW PRESSURE CONTROL	LIMIT SWITCH	OUTDOOR FAN MOTOR	PLUG #1	REY VALVE SOLINOID	START KIT	TOP CAP THERMOSTAT	TRANSFORMER	TERMINAL BLOCK	LOW VOLTAGE TERMINAL BLOCK	THERMAL CUTOFF
CB1	IBR	LAB	LAC	LPR	LPC	LS	OFM	PL1	RV	SK	TC1	T	IB	TBL	TCD

▲ Labeled wires connect if no options used.

▲ Move red wire to 208V tap for 208V operation. ▲ Red (low black (high)

BLACK	BROWN	RED	ORANGE	WHITE	GRAY	Slate	Yellow	Green	Blue	Pink	Lavender
Y	G	R	W	W	BL	SL	Y	GR	BL	P	L

BARD MFG. CO.
 DNG 4096-111A
 DATE 5-11-92
 CHK /APPR.

USE COPPER CONDUCTORS

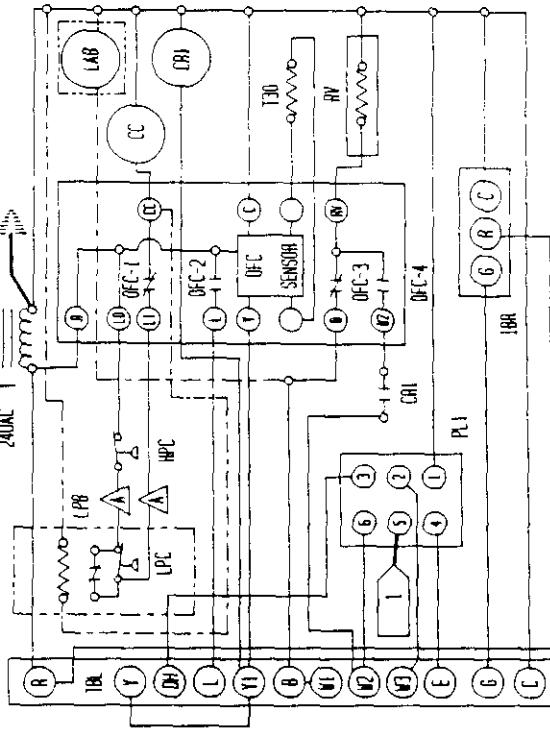
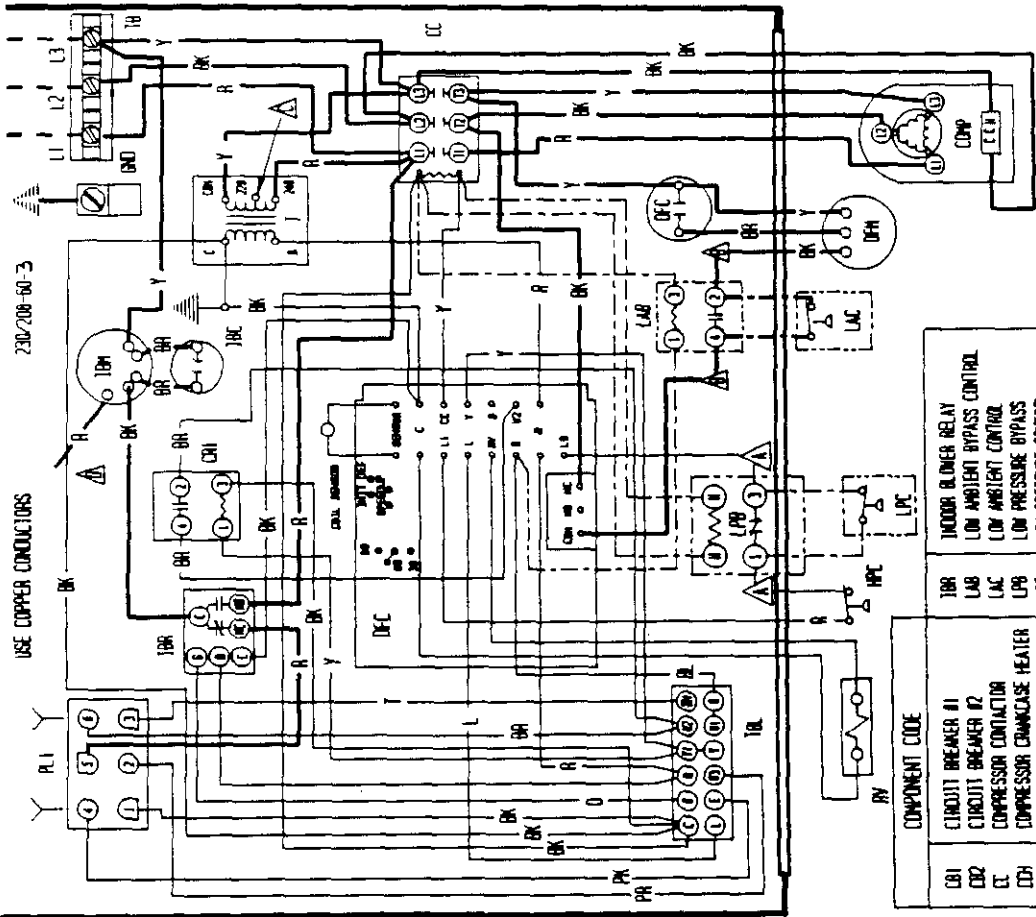
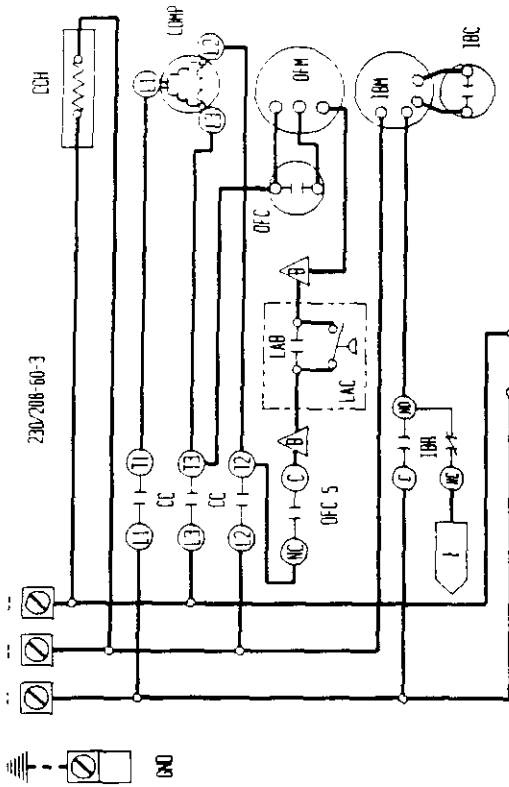

COMPONENT CODE	DESCRIPTION
COB	CIRCUIT BREAKER #1
CO2	CIRCUIT BREAKER #2
CC	COMPRESSOR CONTACTOR
COH	COMPRESSOR CONDENSATE HEATER
COMP	COMPRESSOR
DFC	DEFROST CONTROL
DFR	EMERGENCY HEAT RELAY
EQD	EQUIPMENT GROUND
H1	HEAT STRIP #1
H2	HEAT STRIP #2
HC1	HEATER CONTACTOR #1
HC2	HEATER CONTACTOR #2
HPC	HIGH PRESSURE CONTROL
TBC	INDOOR BLOWER CAPACITOR
IBH	INDOOR BLOWER MOTOR
LAB	INDOOR BLOWER RELAY
LAC	LOW AMBIENT CONTROL
LPA	LOW AMBIENT BYPASS
LPC	LOW PRESSURE BYPASS
LPS	LOW PRESSURE CONTROL
LS	LIMIT SWITCH
OCF	OUTDOOR FAN CAPACITOR
OFB	OUTDOOR FAN MOTOR
OFI	OUTDOOR FAN RELAY
PL1	PLUG #1
RV	REF. VALVE SOL. INOID
T	TRANSFORMER
TB	TERMINAL BLOCK
TBL	LOW VOLTAGE TERMINAL BLOCK
TCD	THERMAL CUTOFF

Labeled Wires Connect if no options used.		Color Code	
Factory Std.	Field	Color	Option
High Voltage	---	Black	---
Low Voltage	---	Brown	---
Accessory	---	Red	---
	---	Orange	---
	---	White	---
	---	Blue	---
	---	Gray	---
	---	Green	---
	---	Purple	---
	---	Pink	---
	---	Lavender	---
	---	Yellow	---
	---	White	---
	---	Black	---

Terminal Block Connections	
Terminal	Color
1	Black
2	Brown
3	Red
4	Orange
5	White
6	Blue
7	Gray
8	Green
9	Purple
10	Pink
11	Lavender
12	Yellow
13	White
14	Black

Wiring Instructions	
Symbol	Description
▲	Move Red Wire to 208V Tap for 208V Operation
△	Red (Low) Black (High)

BARD MFG. CO.
 (MFG) 4055-210A
 DATE _____
 CHK. APPR. _____

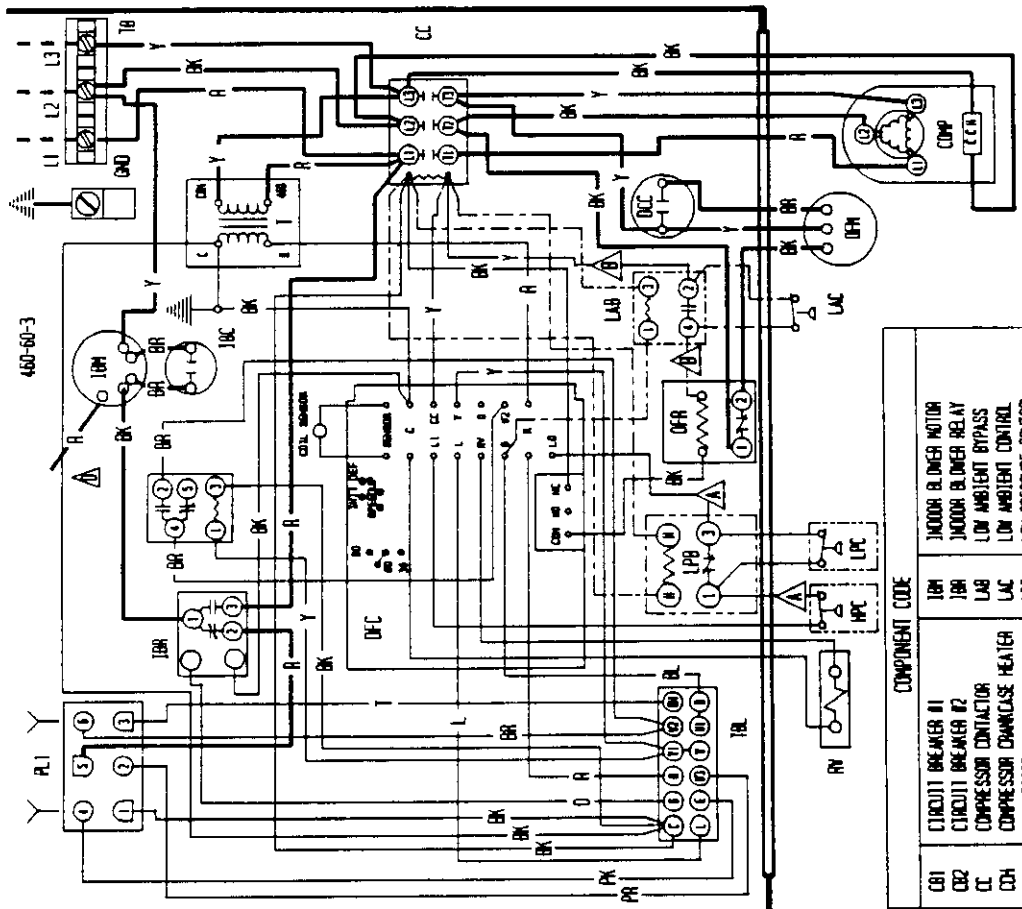
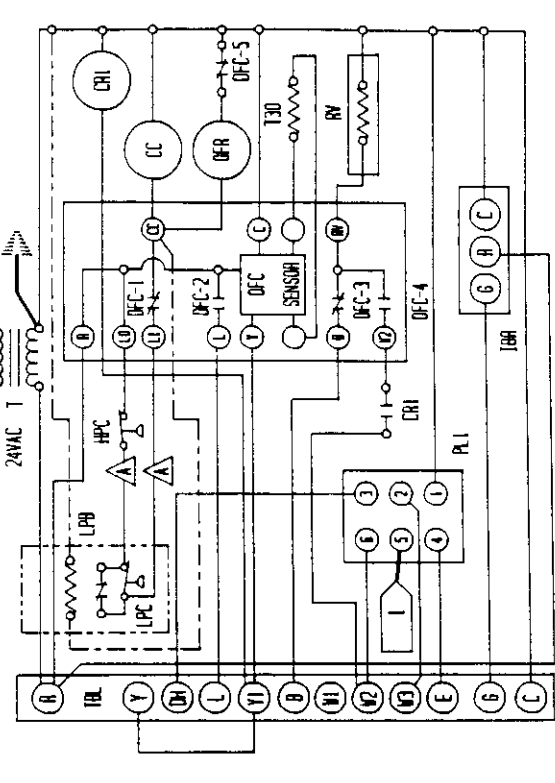
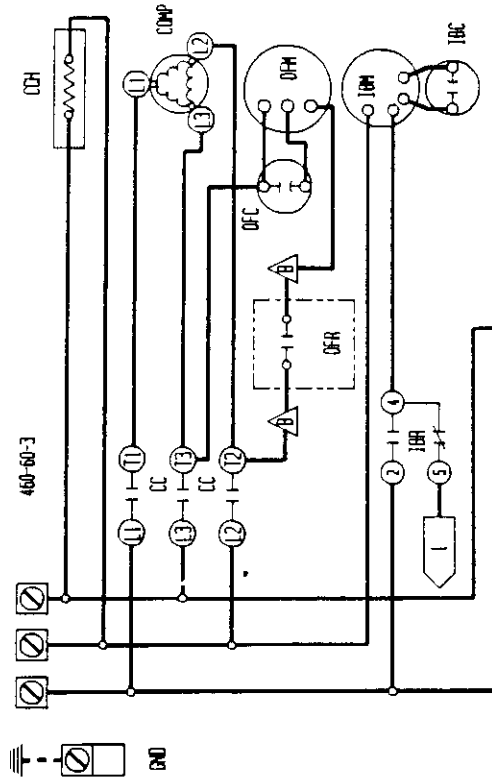

460-60-3

MOVE RED WIRE TO 208V TAP FOR 208V OPERATION

COLOR CODE	TAN
Y	PINK
6	LAVEROER
BL	L
V	SLATE
BR	WHITE
OR	GRAY
RD	BLUE
BRN	BY
BLK	(PH)
YEL	GREEN
YEL	YELLOW
VID ET	PURPLE
PK	PURPLE
PK	PINK
PK	TAN

BARD WFC. CO.
DWG. 4096-310
DATE
CHK. / APPR.

LABELLED WIRES CONNECT IF NO OPTIONS USED.

HIGH VOLTAGE	OPTIONAL
LOW VOLTAGE	---
ACCESSORY	---
FACTORY STD	---
FIELD *	---

COMPONENT CODE	DESCRIPTION
CBI	CIRCUIT BREAKER #1
CB2	CIRCUIT BREAKER #2
CC	COMPRESSOR CONTACTOR
CCH	COMPRESSOR CHARGELASE HEATER
COMP	COMPRESSOR
DLC	DUAL LOW CAPACITOR
DFC	DEFROST CONTROL
EFH	EMERGENCY HEAT RELAY
END	GROUND
H1	HEAT STRIP #1
H2	HEAT STRIP #2
HCA	HEATER CONTACTOR #1
HCB	HEATER CONTACTOR #2
HC2	HIGH PRESSURE CONTROL
IBC	INDOOR BLOWER CAPACITOR
IMH	INDOOR BLOWER MOTOR
IRH	INDOOR BLOWER RELAY
LAB	LOW AMBIENT BYPASS
LAC	LOW AMBIENT CONTROL
LPC	LOW PRESSURE CONTROL
LS	LIMIT SWITCH
OPH	OUTDOOR FAN MOTOR
PL1	PLUG #1
PD	PULL DISCONNECT
RV	REV. VALVE SOLINOID
SK	START KIT
T	TRANSFORMER
TER	TERMINAL BLOCK
TV	LOW VOLTAGE TERMINAL BLOCK
TCO	THERMAL CUTOFF

