

INSTALLATION INSTRUCTIONS

WALL MOUNTED PACKAGE HEAT PUMPS

MODELS

WH181

WH241

DATE: 05-29-94

MANUAL 2100-201 REV. F
SUPERSEDES REV. E
FILE VOL. III, TAB 17

SECTION 1 --GETTING OTHER INFORMATION AND PUBLICATIONS

These publications can help you install the air conditioner or heat pump. You can usually find these at your local library or purchase them directly from the publisher. Be sure to consult current edition of each standard.

National Electrical Code	-ANSI/NFPA 70
Standard For The Installation Of Air Conditioning and Ventilating Systems	-ANSI/NFPA 90A
Standard For Warm Air Heating and Air Conditioning Systems	-ANSI/NFPA 90B
Load Calculation For Residential Winter and Summer Air Conditioning	-ACCA Manual J
Duct Design For Residential Winter and Summer Air Conditioning and Equipment Selection	-ACCA Manual D

FOR MORE INFORMATION, CONTACT THESE PUBLISHERS

ACCA:	AIR CONDITIONING CONTRACTORS OF AMERICA 1513 16th Street NW Washington, DC 20036 Telephone: (202) 483-9370	Fax: (202) 234-4721
ANSI:	AMERICAN NATIONAL STANDARDS INSTITUTE 11 West Street, 13th Floor New York, NY 10036 Telephone: (212) 642-4900	Fax: (212) 302-1286
ASHRAE:	AMERICAN SOCIETY OF HEATING REFRIGERATING AND AIR CONDITIONING ENGINEERS, INCORPORATED 1791 Tullie Circle, N.E. Atlanta, GA 30329-2305 Telephone: (404) 636-8400	Fax: (404) 321-5478
NFPA:	NATIONAL FIRE PROTECTION ASSOCIATION Batterymarch Park P. O. Box 9101 Quincy, MA 02269-9901 Telephone: (800) 344-3555	Fax: (617) 984-7057

Manufactured under the following U.S. patent numbers:
5,301,744; 5,002,116; 4,924,934; 4,875,520; 4,825,936; 4,432,409.
Other patents pending.

COPYRIGHT MAY, 1994
BARD MANUFACTURING COMPANY
BRYAN, OH 43506 USA

TABLE OF CONTENTS

PART 1 -- WALL MOUNT--GENERAL INSTALLATION INFORMATION

Heat Pump Wall Mount Model Nomenclature	1
Shipping Damage	1
General	4
Duct Work	4
Filters	5
Fresh Air Intake	5
Condensate Drain	5

PART 2 -- INSTALLATION

Wall Mounting Information	5
Mounting The Unit	5

WIRING

Wiring--Main Power	7
Wiring: Low Voltage Wiring	7

THERMOSTAT WIRING

Compressor Cut-Off Thermostat and Outdoor Thermostats	8
Compressor Cut-Off and Outdoor Thermostat Wiring	8
Heat Anticipation	9
Thermostat Indicator Lamps	9
Compressor Malfunction Light	9

PART 3 -- START-UP

Important Installer Note	10
Crankcase Heaters	10
Service Hints	10
Sequence of Operation	11
Pressure Service Ports	11
Defrost Cycle	11

PART 4 -- TROUBLESHOOTING

Solid State Heat Pump Control Troubleshooting Procedure	13
Checking Temperature Sensor Outside Unit Circuit	14
Fan Blade Setting Dimensions	15
Removal of The Fan Shroud	15
Refrigerant Charge	15
Pressure Tables	17
Optional Accessories	18

FIGURES AND TABLES

Figure 1	Unit Dimensions	2
Figure 2	Mounting Locations	6
Figure 3	Unit 24V Terminal Board	7
Figure 4	Compressor Cut-Off--5 and 10KW	8
Figure 5	Start-Up	10
Figure 6	Defrost Control Board	12
Figure 7	Fan Blade Setting	15

Table 1	Electric Heat Table	1
Table 2	Electrical Specifications	3
Table 3	Thermostat Wire Sizes	8
Table 4	Wall Thermostat and Subbase Combinations	9
Table 5	Troubleshooting	13
Table 6	Fan Blade Settings.	15
Table 7	Refrigerant Charge	15
Table 8	Indoor Blower Performance	16
Table 9	Recommended Operating Ranges.	16
Table 10	Maximum ESP of Operation	16
Table 11	Cooling--Pressure (PSI)	17
Table 12	Heating--Pressures (PSI)	17
Table 13	Optional Accessories	18

PART 1 -- WALL MOUNT GENERAL INFORMATION

HEAT PUMP WALL MOUNT MODEL NOMENCLATURE

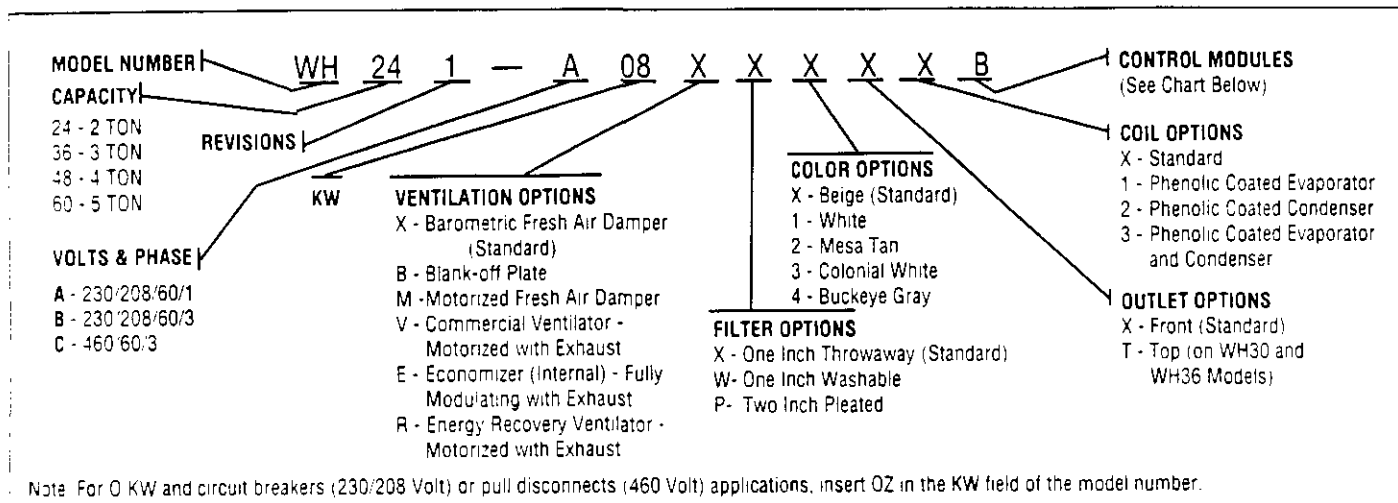

TABLE 1 ELECTRIC HEAT TABLE

Models	WH181-A		WH241-A				WH241-B				WH241-C				
	240-1		208-1		240-1		208-1		240-3		208-3		460-3		
	KW	A	BTU	A	BTU	A	BTU	A	BTU	A	BTU	A	BTU	A	BTU
4	16.7	13650	14.4	10240	16.7	13650	14.4	10240							
8	33.3	27300	28.8	20475	33.3	27300	28.8	20475							
6									14.4	20500	12.5	15360	7.2	20475	

SHIPPING DAMAGE

Upon receipt of equipment, the carton should be checked for external signs of shipping damage. If damage is found, the receiving party must contact the last carrier immediately, preferably in writing, requesting inspection by the carrier's agent.

FIGURE 1
 SIZE SPECS FOR MIS-278

UNIT	WIDTH (W)	DEPTH (D)	HEIGHT (H)	SUPPLY		RETURN		E	F	G	I	J	K	L	M	N	O	P	Q
				A	B	C	B												
18 & 24	32-7/8	16-7/8	70-1/2	7-7/8	19-7/8	11-7/8	19-7/8	34-7/8	18-1/4	25-3/4	20-3/4	26-3/4	28	29-1/4	27	2-9/16	34	22-1/16	10-1/2

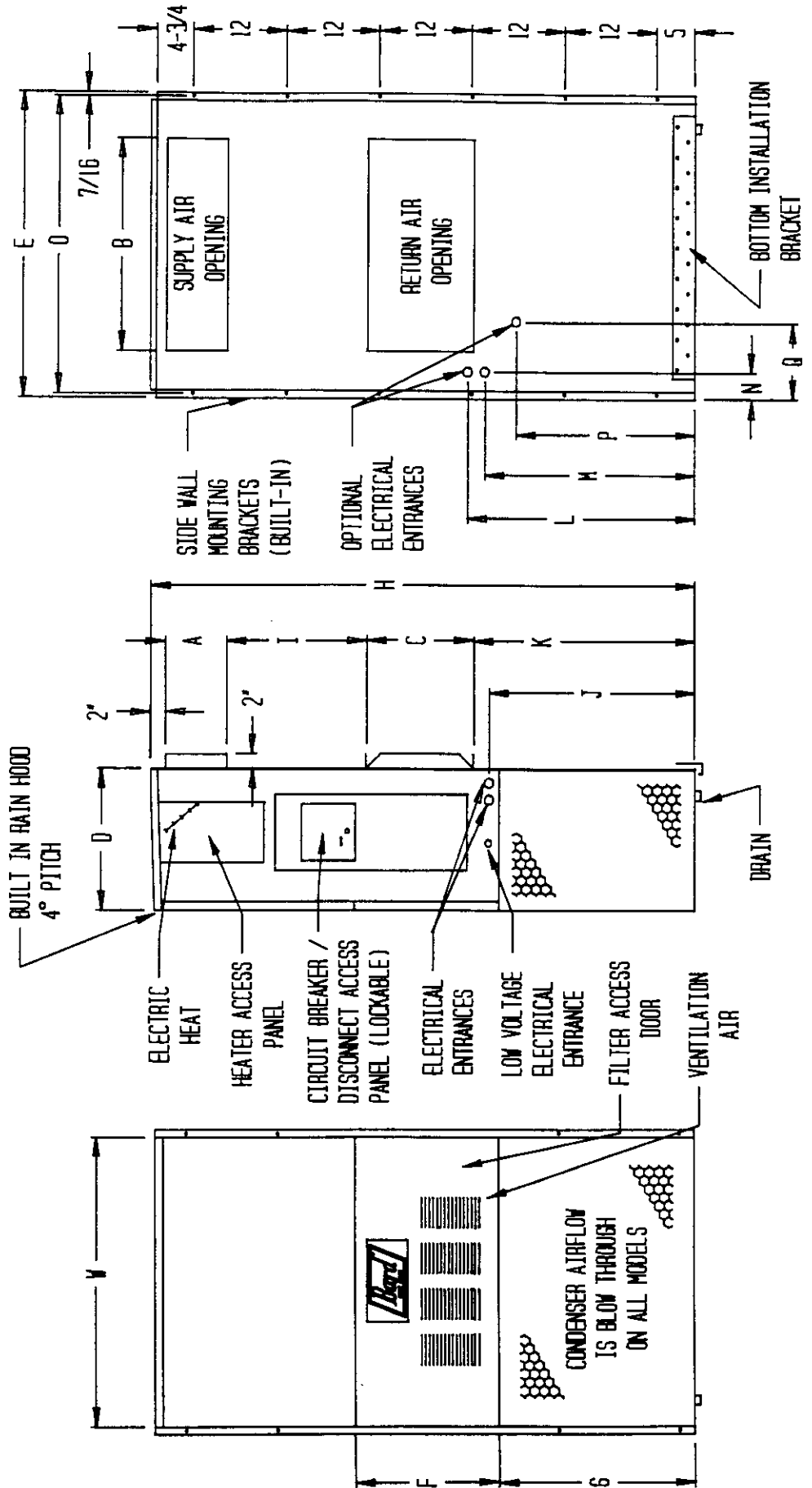

TABLE 2

SINGLE CIRCUIT						
Model	Rated Volts and Phase	No. Field Power Ckts.	(4) Minimum Circuit Ampacity	(1) Maximum External Fuse Or Circuit Breaker	(2) Field Power Wire Size	(2) Ground Wire Size
WH181-A00,A0Z		1	17	20	12	12
AO4	230/208-1	1	38	40	10	10
(3) A08		1	59	60	6	10
WH241-A00,A0Z		1	18	25	12	12
AO4	230/208-1	1	39	40	10	10
(3) A08		1	60	60	6	10
WH241-B00,B0Z		1	15	20	12	12
B06	230/208-3	1	33	35	8	10
WH241-C00,C0Z		1	8	15	14	14
C06	460-3	1	17	20	12	12

(1) Maximum size of the time delay fuse or HACR type circuit breaker for protection of field wiring conductors.

(2) Based on 75°C copper wire. All wiring must conform to NEC and all local codes.

(3) Maximum KW that can operate with heat pump on.

(4) These "Minimum Circuit Ampacity" values are to be used for sizing the field power conductors. Refer to the National Electric Code (latest revision), article 310 for power conductor sizing. Caution: When more than one field power conductor circuit is run thru one conduit, the conductors must be derated. Pay special attention to note 8 of table 310 regarding Ampacity Adjustment Factors when more than 3 are in a raceway.

GENERAL

The equipment covered in this manual is to be installed by trained, experienced service and installation technicians.

The refrigerant system is completely assembled and charged. All internal wiring is complete.

The unit is designed for use with or without duct work. Flanges are provided for attaching the supply and return ducts.

These instructions explain the recommended method to install the air cooled self-contained unit and the electrical wiring connections to the unit.

These instructions and any instructions packaged with any separate equipment required to make up the entire air conditioning system should be carefully read before beginning the installation. Note particularly "Starting Procedure" and any tags and/or labels attached to the equipment.

While these instructions are intended as a general recommended guide, they do not supersede any national and/or local codes in any way. Authorities having jurisdiction should be consulted before the installation is made. See Page 1 for information on codes and standards.

Size of unit for a proposed installation should be based on heat loss calculation made according to methods of Air Conditioning Contractors of America (ACCA). The air duct should be installed in accordance with the Standards of the National Fire Protection Association for the Installation of Air Conditioning and Ventilating systems of Other Than Residence Type, NFPA No. 90A, and Residence Type Warm Air Heating and Air Conditioning Systems, NFPA No. 90B. Where local regulations are at a variance with instructions, installer should adhere to local codes.

DUCT WORK

Any heat pump is more critical of proper operating charge and an adequate duct system than a straight air conditioning unit. All duct work, supply and return, must be properly sized for the design air flow requirement of the equipment. Air Conditioning Contractors of America (ACCA) is an excellent guide to proper sizing. All duct work or portions thereof not in the conditioned space should be properly insulated in order to both conserve energy and prevent condensation or moisture damage.

Refer to Table 10 for maximum static pressure available for duct design.

Design the duct work according to methods given by the Air Conditioning Contractors of America (ACCA). When duct runs through unheated spaces, it should be insulated with a minimum of one inch of insulation. Use insulation with a vapor barrier on the outside of the insulation. Flexible joints should be used to connect the duct work to the equipment in order to keep the noise transmission to a minimum.

A 1/4-inch clearance to combustible material for the first three feet of duct attached to the outlet air frame is required. See Pages 5, 6 and 7 Wall Mounting Instructions and Figures 2 and 2A for further details.

Ducts through the walls must be insulated and all joints taped or sealed to prevent air or moisture entering the wall cavity.

CAUTION: Some installations may not require any return air duct. A metallic return air grille is required with installations not requiring a return air duct. The spacing between louvers on the grille shall not be larger than 5/8 inches.

Any grille that meets the 5/8 inch louver criteria, may be used. It is recommended that Bard Return Air Grille Kit RG2 thru RG5 or REG2 thru REG5 be installed when no return duct is used. Contact distributor or factory for ordering information. If using a return air filter grille, filters must be of sufficient size to allow a maximum velocity of 400 fpm.

NOTE: If no return air duct is used, applicable installation codes may limit this cabinet to installation only in a single story structure.

FILTERS

A 1-inch throwaway filter is supplied with each unit. The filter slides into position making it easy to service. This filter can be serviced from the outside by removing the service door. A 1-inch washable filter and 2-inch pleated filter are also available as optional accessories. The internal filter brackets are adjustable to accommodate the 2-inch filter by loosening 2 screws in each bracket assembly and sliding the brackets apart to the required width and retightening the 4 screws.

FRESH AIR INTAKE

All units are built with a fresh air inlet slots punched in the service panel.

The fresh air damper assembly is standard equipment with the unit because of the variety of state or local codes requiring fresh air capability. It is shipped already attached to each unit.

All capacity, efficiency and cost of operation information as required for Department of Energy "Energyguide" Fact Sheets is based upon the fresh air blank-off plate in place and is recommended for maximum energy efficiency.

The blank-off plate is available upon request from the factory and is installed in place of the fresh air damper shipped with each unit.

CONDENSATE DRAIN

A plastic drain hose extends from the drain pan at the top of the unit down to the unit base. There are openings in the unit base for the drain hose to pass through. In the event the drain hose is connected to a drain system of some type, it must be an open or vented type system to assure proper drainage.

PART 2 -- INSTALLATION INSTRUCTIONS

WALL MOUNTING INFORMATION

1. These units are secured by wall mounting brackets which secure the unit to the outside wall surface at both sides. A bottom mounting bracket is provided for ease of installation, but is not required.
2. On wood-frame walls, the wall construction must be strong and rigid enough to carry the weight of the unit without transmitting any unit vibration.
3. Concrete block walls must be thoroughly inspected to insure that they are capable of carrying the weight of the installing unit.
4. The unit is suitable for 0 inch clearance from the unit and from the supply and return air ducts.

MOUNTING THE UNIT

1. Two holes, for the supply and return air openings, must be cut through the wall as shown in Figure 2.
2. Locate and mark lag bolt locations and bottom mounting bracket location, if desired. See Figure 2.
3. Mount bottom mounting bracket, if used.
4. Hook top rain flashing under back bend of top. Top rain flashing is shipped secured to the right side of the back.
5. Position unit in opening and secure with 5/16 lag bolts; use 7/8" diameter flat washers on the lag bolts.
6. Secure rain flashing to wall and caulk across entire length of top. See Figure 7.
7. For additional mounting rigidity, the return air and supply air frames or collars can be drilled and screwed or welded to the structural wall itself (depending upon wall construction). Be sure to observe required clearance if combustible wall.

FIGURE 2
MOUNTING INSTRUCTIONS

NOTE: IT IS RECOMMENDED THAT A BEAD OF SILICONE CAULKING BE PLACED BEHIND THE SIDE MOUNTING FLANGES AND UNDER THE TOP FLASHING AT TIME OF INSTALLATION.

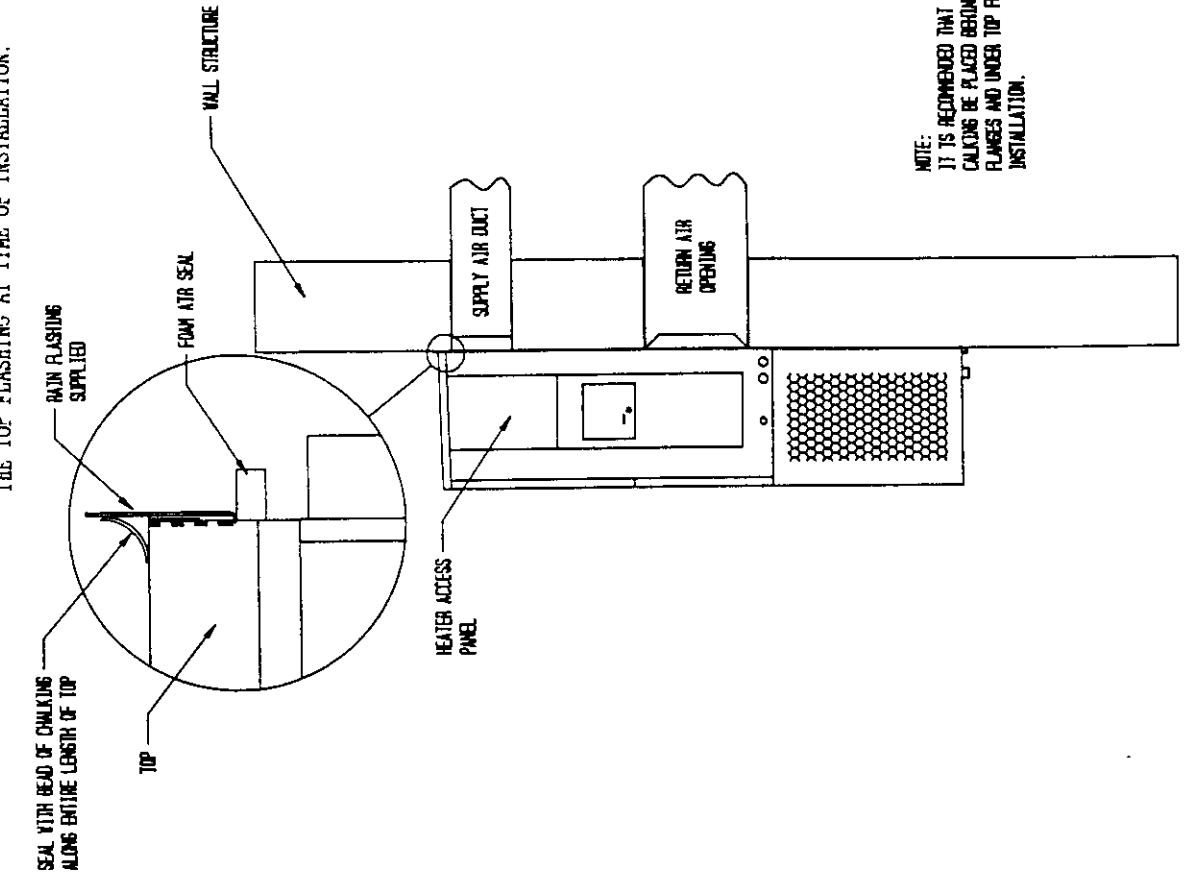

NOTE:
IT IS RECOMMENDED THAT A BEAD OF SILICONE CAULKING BE PLACED BEHIND THE SIDE MOUNTING FLANGES AND UNDER TOP FLASHING AT TIME OF INSTALLATION.

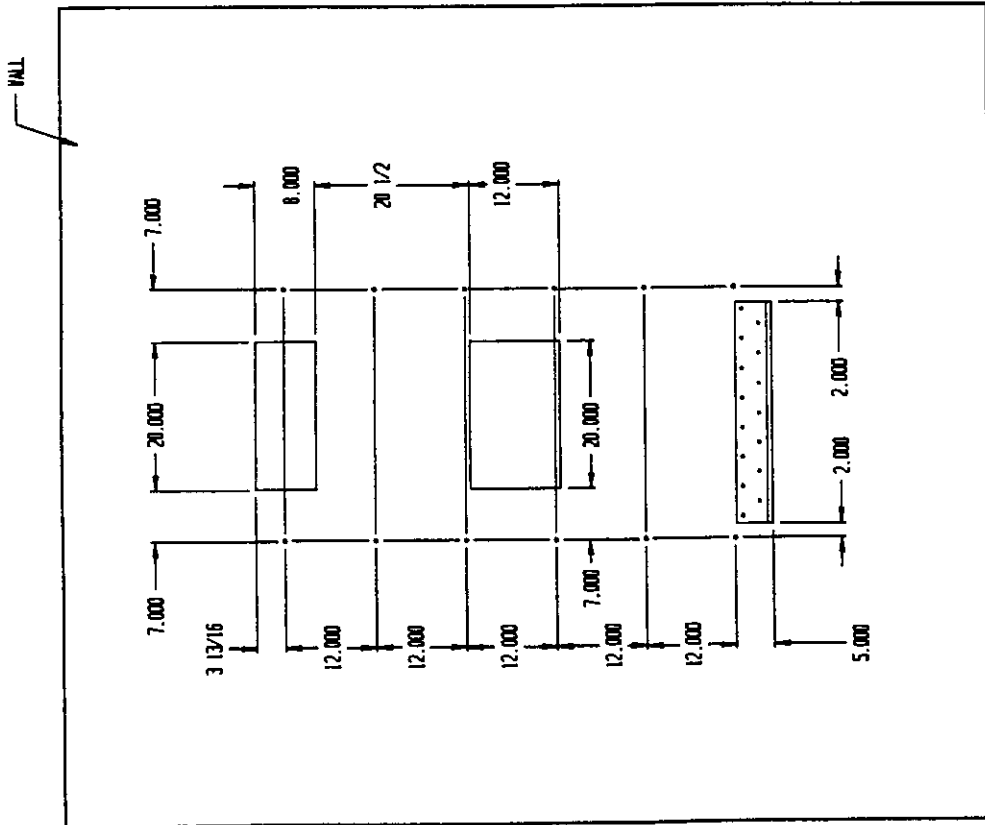

WIRING--MAIN POWER

Refer to the unit rating plate for wire sizing information and maximum fuse or "HACR Type" circuit breaker size. Each outdoor unit is marked with a "Minimum Circuit Ampacity". This means that the field wiring used must be sized to carry that amount of current. Depending on the installed KW of electric heat, there may be two field power circuits required. If this is the case, the unit serial plate will so indicate. All models are suitable only for connection with copper wire. Each unit and/or wiring diagram will be marked "Use Copper Conductors Only". These instructions MUST BE adhered to. Refer to the National Electrical Code (NEC) for complete current carrying capacity data on the various insulation grades of wiring material. All wiring must conform to NEC and all local codes.

The electrical data lists fuse and wire sizes (75°C copper) for all models, including the most commonly used heater sizes. Also shown are the number of field power circuits required for the various models with heaters.

The unit rating plate lists a "Maximum Time Delay Relay Fuse" or "HACR Type" circuit breaker that is to be used with the equipment. The correct size must be used for proper circuit protection and also to assure that there will be no nuisance tripping due to the momentary high starting current of the compressor motor.

The disconnect access door on this unit may be locked to prevent unauthorized access to the disconnect. To convert for the locking capability, bend the tab located in the bottom left hand corner of the disconnect opening under the disconnect access panel straight out. This tab will now line up with the slot in the door. When shut, a padlock may be placed through the hole in the tab preventing entry.

WIRING: LOW VOLTAGE WIRING

230/208V, 1 phase and 3 phase equipment dual primary voltage transformers. All equipment leaves the factory wired on 240V tap. For 208V operation, reconnect from 240V to 208V tap. The acceptable operating voltage range for the 240 and 208V taps are:

TAP	RANGE
240	253 - 216
208	220 - 187

NOTE: The voltage should be measured at the field power connection point in the unit and while the unit is operating at full load (maximum amperage operating condition).

Nine (9) wires should be run from thermostat subbase to the 24V terminal board in the unit. A nine conductor, 18 gauge copper, color-coded thermostat cable is recommended. The connection points are shown below:

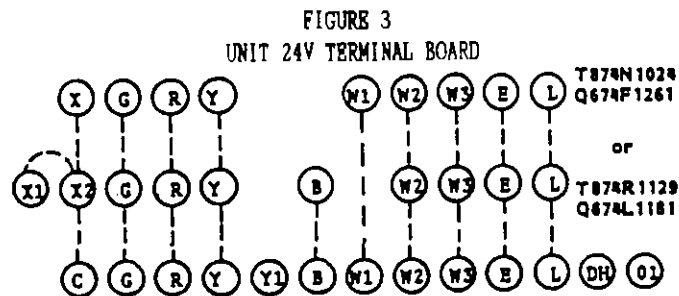

IMPORTANT NOTE: Only the thermostat and subbase combinations as shown above will work with this equipment. The thermostat and subbase MUST be matched, and the correct operation can be assured only by proper selection and application of these parts.

Transformer VA	THERMOSTAT WIRE SIZE		Maximum Distance In Feet
	FLA	Wire Gauge	
55	2.3	20 Gauge	45
		18 "	60
		16 "	100
		14 "	160
		12 "	250

COMPRESSOR CUT-OFF THERMOSTAT AND OUTDOOR THERMOSTATS

Heat pump compressor operation at outdoor temperatures below 0°F are neither desirable nor advantageous in terms of efficiency. Since most equipment at time of manufacture is not designated for any specific destination of the country and most of the equipment is installed in areas not approaching the lower outdoor temperature range, the compressor cut-offs are not factory installed.

Outdoor thermostats are available to hold off various banks of electric heat until needed as determined by outdoor temperature. The set point of either type of thermostat is variable with geographic region and sizing of the heating equipment to the structure. Utilization of the Heating Application Data and the heat loss calculation of the building are useful in determining the correct set points.

COMPRESSOR CUT-OFF AND OUTDOOR THERMOSTAT WIRING

FIGURE 4
4 & 8KW 1-ph --- 6KW 3-ph

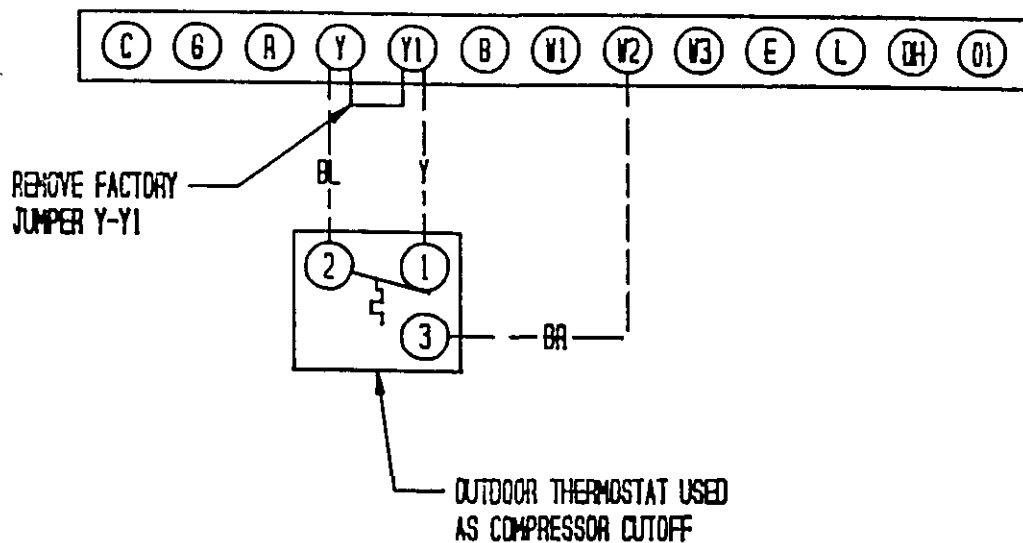

HEAT ANTICIPATION

Both of the thermostats shown below have a fixed heat anticipator for stage 1 with no adjustment required. Stage 2 has an adjustable anticipator for the W2 connection and fixed for the W3 connection. Both the W2 and W3 circuits are controlled by the stage 2 bulb. The only heat anticipator that needs to be checked is stage 2 and it should be set to match the load carried by the W2 circuit. The normal factory wiring provides for only one electric heat contactor to be controlled by W2, and the anticipator should be set at .40A. If special field wiring is done, it is best to actually measure the load but a good rule is .40A for EACH heat contactor controlled by W2.

TABLE 4

WALL THERMOSTAT AND SUBBASE COMBINATIONS			
Group	Thermostat	Subbase	Predominant Features
A	8403-017 (T874R1129)	8404-009 (Q674L1181)	Heat or Cool (1) No Auto
B	8403-018 (T874N1024)	8404-010 (Q674F1261)	Automatic Heat-Cool (2) Changeover Position

- (1) No automatic changeover position--must manually place in heat or cool. Reversing valve remains energized at all times system switch is in heat position (except during defrost cycle). No pressure equalization noise when thermostat is satisfied on either heating or cooling.
- (2) Allows thermostat to control both heating and cooling operation when set in "Auto" position. Reversing valve de-energizes at end of each "On" heating cycle.

IMPORTANT NOTE: Both thermostat and subbase combinations shown above incorporate the following features: Man-Auto fan switch, Off-Heat-Cool-Em. Heat Switch, and two (2) indicator lamps--one for emergency heat and one for compressor malfunction.

THERMOSTAT INDICATOR LAMPS

The green lamp marked "check" will come on if there is any problem that prevents the compressor from running when it is supposed to be.

COMPRESSOR MALFUNCTION LIGHT

Actuation of the green "check" lamp is accomplished by a relay output from the heat pump control board which is factory installed. Any condition such as loss of charge, high head pressure, etc., that will prevent compressor from operating will cause green lamp to activate. This is a signal to the operator of the equipment to place system in emergency heat position.

PART 3 -- START-UP

IMPORTANT INSTALLER NOTE

For improved start-up performance, wash the indoor coil with a dishwasher detergent.

CRANKCASE HEATERS

All units are provided with some form of compressor crankcase heat.

All single and three phase models have an insertion well-type heater located in the lower section of the compressor housing. This is a self-regulating type heater that draws only enough power to maintain the compressor at a safe temperature.

Some form of crankcase heat is essential to prevent liquid refrigerant from migrating to the compressor, causing oil pump out on compressor start-up and possible valve failure due to compressing a liquid.

The decal in Figure 5 is affixed to all outdoor units detailing start-up procedure. This is very important. Please read carefully.

FIGURE 5

IMPORTANT

THESE PROCEDURES MUST BE FOLLOWED AT INITIAL START-UP AND AT ANY TIME POWER HAS BEEN REMOVED FOR 12 HOURS OR LONGER.

TO PREVENT COMPRESSOR DAMAGE WHICH MAY RESULT FROM THE PRESENCE OF LIQUID REFRIGERANT IN THE COMPRESSOR CRANKCASE

1. MAKE CERTAIN THE ROOM THERMOSTAT IS IN THE "OFF" POSITION (THE COMPRESSOR IS NOT TO OPERATE).
2. APPLY POWER BY CLOSING THE SYSTEM DISCONNECT SWITCH THIS ENERGIZES THE COMPRESSOR HEATER WHICH EVAPORATES THE LIQUID REFRIGERANT IN THE CRANKCASE.
3. ALLOW 4 HOURS OR 60 MINUTES PER POUND OF REFRIGERANT IN THE SYSTEM AS NOTED ON THE UNIT RATING PLATE, WHICHEVER IS GREATER.
4. AFTER PROPERLY ELAPSED TIME THE THERMOSTAT MAY BE SET TO OPERATE THE COMPRESSOR.
5. EXCEPT AS REQUIRED FOR SAFETY WHILE SERVICING — DO NOT OPEN SYSTEM DISCONNECT SWITCH.

7961-061

SERVICE HINTS

1. Caution homeowner to maintain clean air filters at all times. Also, not to needlessly close off supply and return air registers. This reduces air flow through the system, which shortens equipment service life as well as increasing operating costs.
2. Switching to heating cycle at 75°F or higher outside temperature may cause a nuisance trip of the remote reset high pressure switch. Turn thermostat off, then on to reset the high pressure switch.
3. The heat pump wall thermostats perform multiple functions. Be sure that all function switches are correctly set for the desired operating mode before trying to diagnose any reported service problems.
4. Check all power fuses or circuit breakers to be sure they are the correct rating.
5. Periodic cleaning of the outdoor coil to permit full and unrestricted airflow circulation is essential.

SEQUENCE OF OPERATION

COOLING--Circuit R-Y makes at thermostat pulling in compressor contactor, starting the compressor and outdoor motor. The G (indoor motor) circuit is automatically completed on any call for cooling operation or can be energized by manual fan switch on subbase for constant air circulation.

HEATING--A 24V solenoid coil on reversing valve controls heating cycle operation. Two thermostat options, one allowing "Auto" changeover from cycle to cycle and the other constantly energizing solenoid coil during heating season and thus eliminating pressure equalization noise except during defrost, are to be used. On "Auto" option, a circuit is completed from R-W1 and R-Y on each heating "on" cycle, energizing reversing valve solenoid and pulling in compressor contactor starting compressor and outdoor motor. R-G also make starting indoor blower motor. Heat Pump heating cycle now in operation. The second option has no "Auto" changeover position, but instead energizes the reversing valve solenoid constantly whenever the system switch on subbase is placed in "Heat" position, the "B" terminal being constantly energized from R. A thermostat demand for heat completes R-Y circuit, pulling in compressor contactor starting compressor and outdoor motor. R-G also make starting indoor blower motor.

PRESSURE SERVICE PORTS

High and low pressure service ports are installed on all units so that the system operating pressures can be observed. Pressure curves can be found later in the manual covering all models on both cooling and heating cycles. It is imperative to match the correct pressure curve to the unit by model number.

DEFROST CYCLE

The defrost cycle is controlled by temperature and time on the solid state heat pump control.

When the outdoor temperature is in the lower 40°F temperature range or colder, the outdoor coil temperature is 32°F or below. This coil temperature is sensed by the coil sensor mounted near the bottom of the outdoor coil. Once coil temperature reaches 30°F or below, the coil sends a signal to the control logic of the heat pump control and the defrost timer will start.

After 60 (90 or 30) minutes at 30°F or below, the heat pump control will place the system in the defrost mode.

During the defrost mode, the refrigerant cycle switches back to the cooling cycle, the outdoor motor stops, electric heaters are energized, and hot gas passing through the outdoor coil melts any accumulator frost. When the temperature rises to approximately 57°F, the coil sensor will send a signal to the heat pump control which will return the system to heating operations automatically.

If some abnormal or temporary condition such as a high wind causes the heat pump to have a prolonged defrost cycle, the heat pump control will restore the system to heating operation automatically after 10 minutes.

There are three settings on the heat pump control--30 minute, 60 minute, and 90 minute. Most models are shipped wired on the 60 minute setting for greatest operating economy. If special circumstances require a change to another time, remove wire connected to terminal 60 and reconnect to desired terminal.

There is a cycle speed up jumper on the control. This can be used to reduce the time between defrost cycle operation without waiting for time to elapse.

There is an initial defrost (sen jmp) jumper on the control that can be used at any outdoor ambient during the heating cycle to simulate a 0° coil temperature. This can be used to check defrost operation of the unit without waiting for the outdoor ambient to fall into the defrost region.

FIGURE 6
DEFROST CONTROL BOARD

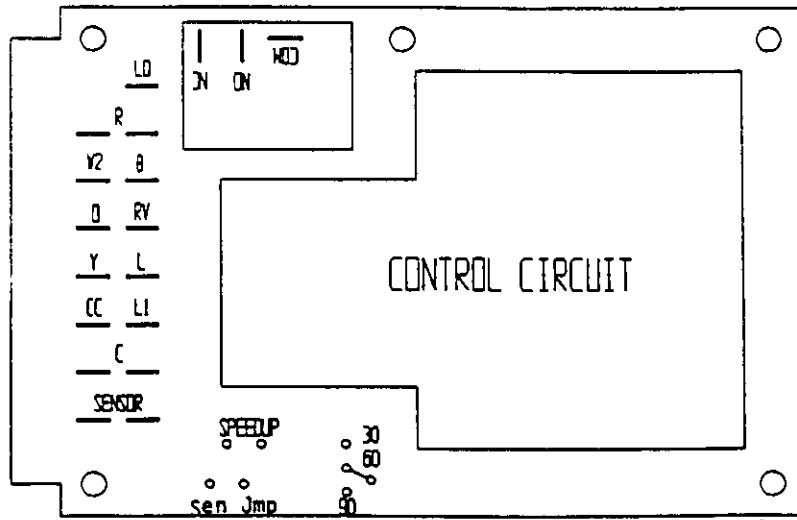

PART 4 -- TROUBLESHOOTING

SOLID STATE HEAT PUMP CONTROL TROUBLESHOOTING PROCEDURE

1. Turn on AC power supply to indoor and outdoor units.
2. Turn thermostat blower switch to fan on--the indoor blower should start. (If it doesn't, troubleshoot indoor unit and correct problem).
3. Turn thermostat blower switch to auto position. Indoor blower should stop.
4. Set system switch to heat or cool. Adjust thermostat to call for heat or cool--The indoor blower, compressor, and outdoor fan should start.

NOTE: If there was no power to 24 volt transformer, the compressor and outdoor fan motor will not start for 5 minutes. This is because of the compressor short cycle protection.

TABLE 5 TROUBLESHOOTING

Symptom	Possible Causes	What to Check	How To Check Or Repair
Compressor contactor does not energize (cooling or heating)	Control circuit wiring	Check for R connection at unit, and 24V between R-C.	Run R connection to outdoor unit to power heat pump control.
	Compressor lock out	1. Check for 24V between L1-C on heat pump control. 2. Check across high pressure switch.	1. If no voltage between L1-C turn thermostat off and on again to reset high pressure switch. 2. If high pressure switch is open and will not reset, replace high pressure switch.
	Compressor short cycle protection	Check for 24V between CC-C and Y-C on heat pump control.	1. If no voltage between CC-C jumper speed up terminal and within 10 seconds power should appear between CC-C. Remove speed up jumper after 10 seconds.
	Heat pump control defective	Check all other possible causes. Manual 2100-065	Replace heat pump control.
	Contactors defective	Check for open or shorted coil winding.	Replace contactor.
Fan outdoor motor does not run (cooling or heating except during defrost)	Motor defective	Check for open or shorted motor winding	Replace motor.
	Motor capacitor defective	Check capacitor rating. Check for open or shorted capacitor.	Replace capacitor.
	Heat pump control defective	Check across fan relay on heat pump control. (Com-NC)	Replace heat pump control.
Reversing valve does not energize (heating only)	Reversing valve solenoid coil defective	Check for open or shorted coil.	Replace solenoid coil.
	Heat pump control defective	Check for 24V between RV-C and B-C.	1. Check control circuit wiring. 2. Replace heat pump control.
Unit will not go into defrost (heating only)	Temperature sensor or heat pump control defective	Disconnect temperature sensor from board and jumper across speed up terminals and sen jmp terminals. This should cause the unit to go through a defrost cycle within one minute.	1. If unit goes through defrost cycle, replace temperature sensor. 2. If unit does not go through defrost cycle, replace heat pump control.
Unit will not come out of defrost (heating only)	Temperature sensor or heat pump control defective	Jumper across speed up terminals. This should cause the unit to come out of defrost within one minute.	1. If unit comes out of defrost cycle, replace temperature sensor. 2. If unit does not come out of defrost cycle, replace heat pump control.

CHECKING TEMPERATURE SENSOR OUTSIDE UNIT CIRCUIT

1. Disconnect temperature sensor from board and from outdoor coil.
2. Use an ohmmeter and measure the resistance of the sensor. Also use ohmmeter to check for short or open.
3. Check resistance reading to chart of resistance use sensor ambient temperature. (Tolerance of part is $\pm 10\%$).
4. If sensor resistance reads very low, then sensor is shorted and will not allow proper operation of the heat pump control.
5. If sensor is out of tolerance, shorted, open, or reads very low ohms then it should be replaced.

TEMPERATURE F VS RESISTANCE R OF TEMPERATURE SENSOR

F	R	F	R	F	R
-25.0	196871	25.0	39898	75.0	10501
-24.0	190099	26.0	38757	76.0	10247
-23.0	183585	27.0	37652	77.0	10000
-22.0	177318	28.0	36583	78.0	9760
-21.0	171289	29.0	35548	79.0	9526
-20.0	165487	30.0	34545	80.0	9299
-19.0	159904	31.0	33574	81.0	9077
-18.0	154529	32.0	32634	82.0	8862
-17.0	149355	33.0	31723	83.0	8653
-16.0	144374	34.0	30840	84.0	8449
-15.0	139576	35.0	29986	85.0	8250
-14.0	134956	36.0	29157	86.0	8057
-13.0	130506	37.0	28355	87.0	7869
-12.0	126219	38.0	27577	88.0	7686
-11.0	122089	39.0	26823	89.0	7507
-10.0	118108	40.0	26092	90.0	7334
-9.0	114272	41.0	25383	91.0	7165
-8.0	110575	42.0	24696	92.0	7000
-7.0	107010	43.0	24030	93.0	6840
-6.0	103574	44.0	23384	94.0	6683
-5.0	100260	45.0	22758	95.0	6531
-4.0	97064	46.0	22150	96.0	6383
-3.0	93981	47.0	21561	97.0	6239
-2.0	91008	48.0	20989	98.0	6098
-1.0	88139	49.0	20435	99.0	5961
0.0	85371	50.0	19896	100.0	5827
1.0	82699	51.0	19374	101.0	5697
2.0	80121	52.0	18867	102.0	5570
3.0	77632	53.0	18375	103.0	5446
4.0	75230	54.0	17898	104.0	5326
5.0	72910	55.0	17434	105.0	5208
6.0	70670	56.0	16984	106.0	5094
7.0	68507	57.0	16547	107.0	4982
8.0	66418	58.0	16122	108.0	4873
9.0	64399	59.0	15710	109.0	4767
10.0	62449	60.0	15310	110.0	4663
11.0	60565	61.0	14921	111.0	4562
12.0	58745	62.0	14544	112.0	4464
13.0	56985	63.0	14177	113.0	4367
14.0	55284	64.0	13820	114.0	4274
15.0	53640	65.0	13474	115.0	4182
16.0	52051	66.0	13137	116.0	4093
17.0	50514	67.0	12810	117.0	4006
18.0	49028	68.0	12492	118.0	3921
19.0	47590	69.0	12183	119.0	3838
20.0	46200	70.0	11883	120.0	3757
21.0	44855	71.0	11591	121.0	3678
22.0	43554	72.0	11307	122.0	3601
23.0	42295	73.0	11031	123.0	3526
24.0	41077	74.0	10762	124.0	3452

FAN BLADE SETTING DIMENSIONS

Shown in the drawing below are the correct fan blade setting dimensions for proper air delivery across the outdoor coil.

Any service work requiring removal or adjustment in the fan and/or motor area will require that the dimensions below be checked and blade adjusted in or out on the motor shaft accordingly.

FIGURE 7

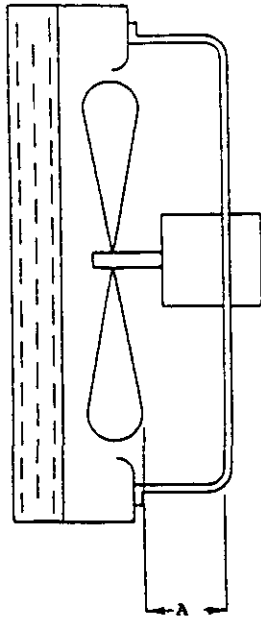

TABLE 6

Model	Dimension A
WH181	1.00
WH241	

REMOVAL OF THE FAN SHROUD

1. Disconnect all power to unit.
2. Remove the screws holding both grills--one on each side of unit--and remove grills.
3. Remove screws holding fan shroud to condenser and bottom. (9) screws.
4. Unwire condenser fan motor.
5. Slide complete motor, fan blade, and shroud assembly out the left side of the unit.
6. Service motor/fan as needed.
7. Reverse steps to reinstall.

REFRIGERANT CHARGE

The correct system R-22 charge is shown on the unit rating plate. Optimum unit performance will occur with a refrigerant charge resulting in a suction line temperature (6" from compressor) as shown in the following table:

TABLE 7

Model	Rated Airflow	° 95 F OD Temperature	° 82 F OD Temperature
WH181	650	56 - 58	63 - 65
WH241	800	57 - 59	65 - 67

The above suction line temperatures are based upon 80°F dry bulb/67°F wet bulb (50% R.H.) temperature and rated airflow across the evaporator during cooling cycle.

TABLE 8 INDOOR BLOWER PERFORMANCE--CFM @ 230V

E.S.P. In H2O	WH181, WH241
	Dry / Wet
.0	1020 / 975
.1	960 / 905
.2	865 / 800
.3	820 / 735
.4	735 / 650
.5	615 / 535
.6	---

TABLE 9

Model	Rated CFM*	Rated ESP*	Recommended Airflow Range
WH181	650	.40	575 - 725
WH241	800	.20	700 - 950

*Rated CFM and ESP on high speed tap.

TABLE 10 MAXIMUM ESP OF OPERATION

Model	ESP
A00	.50
WH181 A04	.50
WH241 A08	.40
B00	.50
WH241 B06	.50
C00	.50
WH241 C06	.50

Values shown are for units equipped with STD 1" throw-away filter or 1" washable filter. Derate ESP by .15 for 2" pleated filters.

TABLE 11

COOLING

Air Temperature Entering Outdoor Coil °F

Model	Return Air Temperature	Pressure	°	°	°	°	°	°	°	°	°
			75	80	85	90	95	100	105	110	115
WB181	75 deg. DB	Low Side	77	78	80	81	83	84	86	87	89
	62 deg. WB	High Side	193	209	224	240	255	271	287	302	318
	80 deg. DB	Low Side	82	84	85	87	89	90	92	93	95
	67 deg. WB	High Side	198	214	230	246	262	278	294	310	326
	85 deg. DB	Low Side	88	90	92	94	95	97	99	100	102
	72 deg. WB	High Side	205	222	238	255	271	288	304	321	337
WB241	75 deg. DB	Low Side	75	76	77	79	80	81	83	84	86
	62 deg. WB	High Side	216	229	242	256	271	286	302	318	336
	80 deg. DB	Low Side	80	81	83	84	85	87	88	90	92
	67 deg. WB	High Side	221	235	248	263	278	293	310	327	344
	85 deg. DB	Low Side	86	88	89	90	92	93	95	97	99
	72 deg. WB	High Side	229	243	257	272	288	304	321	338	356

TABLE 12

HEATING

Air Temperature Entering Outdoor Coil °F

Model	Return Air Temperature	Pressure	0	5	10	15	17	20	25	30	35	40	45	47	50	55	60
			WB181	70°	Low Side	20	24	27	31	32	35	39	44	49	54	59	62
High Side	178	181			184	189	191	194	201	208	216	225	235	239	246	257	270
WB241	70°	Low Side	30	30	31	32	33	34	37	41	45	50	56	59	63	71	79
		High Side	158	158	159	162	164	167	175	184	195	208	223	230	241	260	281

Low side pressure \pm 2 PSIGHigh side pressure \pm 5 PSIG

Tables are based upon rated CFM (airflow) across the evaporator coil and should be found under section titled "Refrigerant Charge" elsewhere in manual. If there is any doubt as to correct operating charge being in the system, the charge should be removed, system evacuated, and recharged to serial plate instructions.

TABLE 13

OPTIONAL ACCESSORIES

Model	Description	W	W	W	W
		H	H	H	H
		1	2	2	2
		8	4	4	4
		1	1	1	1
		-	-	-	-
		A	A	B	C
EHWH02-A05	Heater Packages	x	x		
EHWH02-A10	Heater Packages	x	x		
EHWH24-B06	Heater Packages			x	
EHWH24-C06	Heater Packages				x
BOP-2	Blank Off Plate	x	x	x	x
BFAD-2	Barometric Fresh Air Damper	x	x	x	x
MEAD-2	Motorized Fresh Air Damper	x	x	x	x
CRV-2	Classroom Ventilator With Exhaust	x	x	x	x
EIEF-2	Economizer With Exhaust	x	x	x	x
WERV-A2A	Energy Recovery Ventilator	x	x	x	
CMH-3	Low Pressure Control (LPC)	x	x	x	x
CMH-7	Low Ambient Control (LAC)	x	x	x	
CMH-9	LAC + LPC	x	x	x	
CMH-14	Outdoor Thermostat (ODT)	x	x		
CMC-15	Start Skit (SK)	x	x		
WMCB-02A	Circuit Breaker Kit	x			
WMCB-03A	Circuit Breaker Kit		x		
WMCB-02B	Circuit Breaker Kit			x	
WMPD-01C	Pull Disconnect Kit				x

COMPONENT CODE	
BR1	CIRCUIT BREAKER #1
BR2	CIRCUIT BREAKER #2
IC	COMPRESSOR CONTACTOR
OMP	COMPRESSOR
OR1	CONTROL RELAY
OC	LOW OIL CAPACITOR
OC1	LOW OIL CAPACITOR
OC2	LOW OIL CAPACITOR
OC3	LOW OIL CAPACITOR
OC4	LOW OIL CAPACITOR
OC5	LOW OIL CAPACITOR
OC6	LOW OIL CAPACITOR
OC7	LOW OIL CAPACITOR
OC8	LOW OIL CAPACITOR
OC9	LOW OIL CAPACITOR
OC10	LOW OIL CAPACITOR
OC11	LOW OIL CAPACITOR
OC12	LOW OIL CAPACITOR
OC13	LOW OIL CAPACITOR
OC14	LOW OIL CAPACITOR
OC15	LOW OIL CAPACITOR
OC16	LOW OIL CAPACITOR
OC17	LOW OIL CAPACITOR
OC18	LOW OIL CAPACITOR
OC19	LOW OIL CAPACITOR
OC20	LOW OIL CAPACITOR
OC21	LOW OIL CAPACITOR
OC22	LOW OIL CAPACITOR
OC23	LOW OIL CAPACITOR
OC24	LOW OIL CAPACITOR
OC25	LOW OIL CAPACITOR
OC26	LOW OIL CAPACITOR
OC27	LOW OIL CAPACITOR
OC28	LOW OIL CAPACITOR
OC29	LOW OIL CAPACITOR
OC30	LOW OIL CAPACITOR
OC31	LOW OIL CAPACITOR
OC32	LOW OIL CAPACITOR
OC33	LOW OIL CAPACITOR
OC34	LOW OIL CAPACITOR
OC35	LOW OIL CAPACITOR
OC36	LOW OIL CAPACITOR
OC37	LOW OIL CAPACITOR
OC38	LOW OIL CAPACITOR
OC39	LOW OIL CAPACITOR
OC40	LOW OIL CAPACITOR
OC41	LOW OIL CAPACITOR
OC42	LOW OIL CAPACITOR
OC43	LOW OIL CAPACITOR
OC44	LOW OIL CAPACITOR
OC45	LOW OIL CAPACITOR
OC46	LOW OIL CAPACITOR
OC47	LOW OIL CAPACITOR
OC48	LOW OIL CAPACITOR
OC49	LOW OIL CAPACITOR
OC50	LOW OIL CAPACITOR
OC51	LOW OIL CAPACITOR
OC52	LOW OIL CAPACITOR
OC53	LOW OIL CAPACITOR
OC54	LOW OIL CAPACITOR
OC55	LOW OIL CAPACITOR
OC56	LOW OIL CAPACITOR
OC57	LOW OIL CAPACITOR
OC58	LOW OIL CAPACITOR
OC59	LOW OIL CAPACITOR
OC60	LOW OIL CAPACITOR
OC61	LOW OIL CAPACITOR
OC62	LOW OIL CAPACITOR
OC63	LOW OIL CAPACITOR
OC64	LOW OIL CAPACITOR
OC65	LOW OIL CAPACITOR
OC66	LOW OIL CAPACITOR
OC67	LOW OIL CAPACITOR
OC68	LOW OIL CAPACITOR
OC69	LOW OIL CAPACITOR
OC70	LOW OIL CAPACITOR
OC71	LOW OIL CAPACITOR
OC72	LOW OIL CAPACITOR
OC73	LOW OIL CAPACITOR
OC74	LOW OIL CAPACITOR
OC75	LOW OIL CAPACITOR
OC76	LOW OIL CAPACITOR
OC77	LOW OIL CAPACITOR
OC78	LOW OIL CAPACITOR
OC79	LOW OIL CAPACITOR
OC80	LOW OIL CAPACITOR
OC81	LOW OIL CAPACITOR
OC82	LOW OIL CAPACITOR
OC83	LOW OIL CAPACITOR
OC84	LOW OIL CAPACITOR
OC85	LOW OIL CAPACITOR
OC86	LOW OIL CAPACITOR
OC87	LOW OIL CAPACITOR
OC88	LOW OIL CAPACITOR
OC89	LOW OIL CAPACITOR
OC90	LOW OIL CAPACITOR
OC91	LOW OIL CAPACITOR
OC92	LOW OIL CAPACITOR
OC93	LOW OIL CAPACITOR
OC94	LOW OIL CAPACITOR
OC95	LOW OIL CAPACITOR
OC96	LOW OIL CAPACITOR
OC97	LOW OIL CAPACITOR
OC98	LOW OIL CAPACITOR
OC99	LOW OIL CAPACITOR
OC100	LOW OIL CAPACITOR

WIRE COLOR CODE	
BR	BLACK
BRN	BROWN
RED	RED
ORNG	ORANGE
Y	YELLOW
GRN	GREEN
BLU	BLUE
WHT	WHITE
V	VIOLET
FR	FLUORESCENT
GRY	GRAY
SLV	SILVER
1	1/4"
PK	PINK
LANG	LAMP

WIRE COLOR CODE	
BR	BLACK
BRN	BROWN
RED	RED
ORNG	ORANGE
Y	YELLOW
GRN	GREEN
BLU	BLUE
WHT	WHITE
V	VIOLET
FR	FLUORESCENT
GRY	GRAY
SLV	SILVER
1	1/4"
PK	PINK
LANG	LAMP

WIRE COLOR CODE	
BR	BLACK
BRN	BROWN
RED	RED
ORNG	ORANGE
Y	YELLOW
GRN	GREEN
BLU	BLUE
WHT	WHITE
V	VIOLET
FR	FLUORESCENT
GRY	GRAY
SLV	SILVER
1	1/4"
PK	PINK
LANG	LAMP

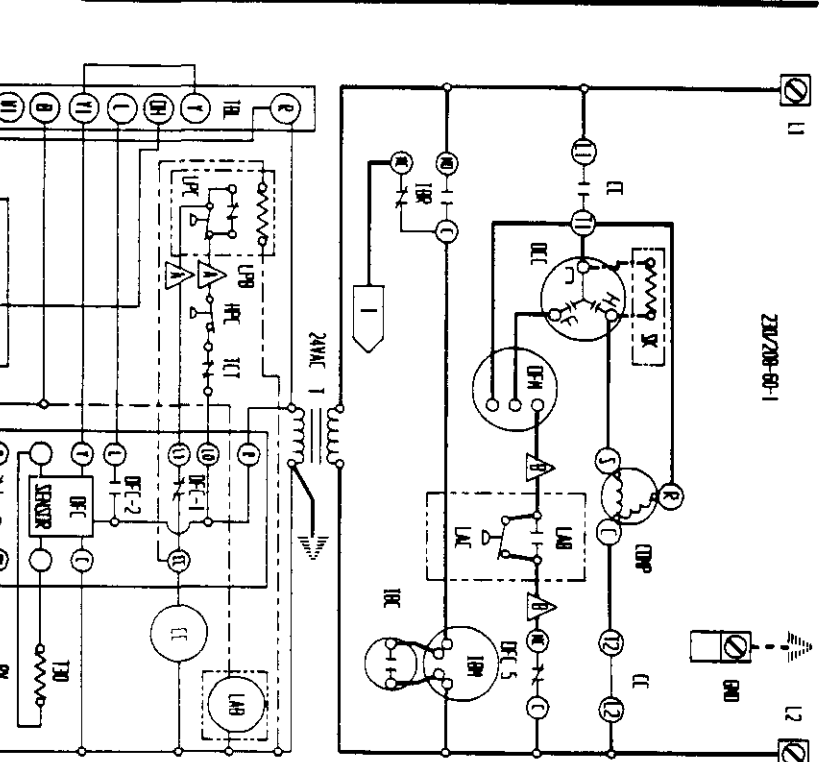
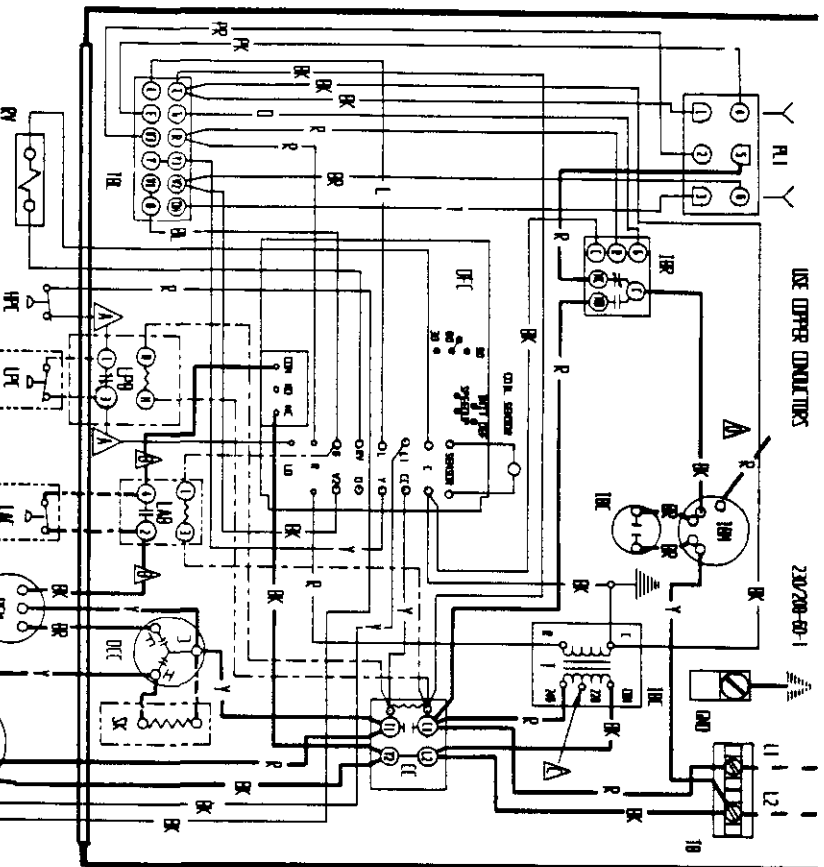

REVISIONS

REV.	DATE	DESCRIPTION
1	5-11-92	INITIAL DESIGN