

INSTALLATION INSTRUCTIONS

SPLIT HEAT PUMP OUTDOOR SECTION

MODELS

24HPQ6

30HPQ6

36HPQ7

42HPQ4

48HPQ5

60HPQ5

50HZ

**FOR USE WITH:
MATCHING INDOOR BLOWER
COIL UNITS AND MATCHING
ADD ON COIL UNITS ONLY**

MANUAL 2100-205 REV.
SUPERSEDES REV.
FILE VOL. I, TAB 5

COPYRIGHT MAY, 1992
BARD MANUFACTURING COMPANY
BRYAN, OHIO

TABLE OF CONTENTS

I.	Application and Location	4
	General	4
	Shipping Damage	4
	Application	4
	Location	4
	Setting The Unit.	4
	Slab Mounting	6
	Roof Mounting	6
	Winter Installation Below 32 Degree F	6
	Important Installer Note	6
	Installing Refrigerant Tubing	7
II.	Wiring Instructions	9
	General	9
	Outdoor Thermostat	9
	Sequence of Operation When Used With Indoor Blower Coil	10
	General Operation--Heat Pump/Fossil Fuel Furnace	10
	Thermostat Indicator Lamp	10
	Defrost Cycle	11
	Crankcase Heaters	12
	Emergency Heat Position	12
III.	Charging Instructions	13
	Pressure Service Ports	13
	Refrigerant Charge	13
	Total System Charge For Split Systems	14
IV.	Service	16
	Pressure Tables	17

FIGURES AND TABLES

Figure 1	1
Figure 2	5
Figure 3	5
Figure 4	5
Figure 5	5
Figure 6	6
Figure 7	9
Figure 8	11
Figure 9	12

Table 1	1
Table 2	2
Table 3	3
Table 4	7
Table 5	10
Table 6	13
Table 7	14
Table 8	15
Table 9	17
Table 10	17
Table 11	17
Table 12	17
Table 13	18
Table 14	18
Table 15	18
Table 16	18
Table 17	19
Table 18	19
Table 19	19
Table 20	19

FIGURE 1

NOMENCLATURE EXPLANATION--Example:

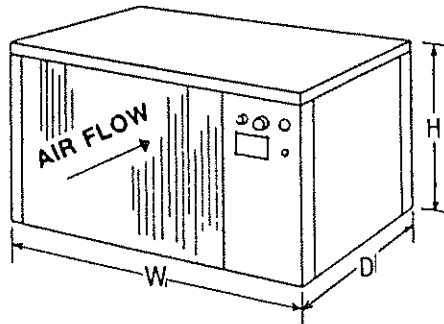
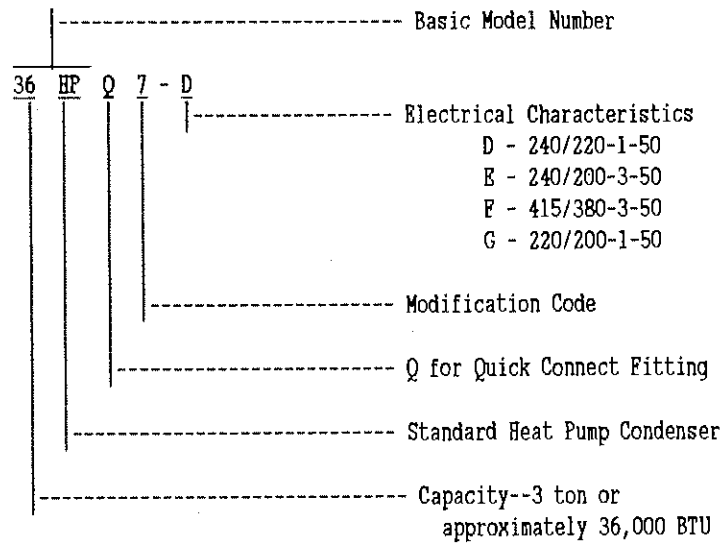

TABLE 1

DIMENSIONS			
Model No.	"W" Width	"D" Depth	"H" Height
24HPQ6	36"	18"	21"
30HPQ6 36HPQ7	40-3/8"	23-1/4"	23-1/4"
42HPQ4 48HPQ5 60HPQ5	46-1/2"	23-1/4"	31-1/2"

TABLE 2

Condensing Unit Model Number	Indoor Coil			Rated Air Flow		Required Refrigerant Control Orifice Size
	Model	(1) Type	Speed	CFM	(3) H ₂ O	
24HPQ6-D	BC24B	B	H	650	.35	.059
30HPQ6-D	BC30B	B	H	700	.15	.063
	BC35B	B	H	900	.35	Cap Tube
	BC36B	B	H	900	.35	.061 (2)
36HPQ7-D	BC35B	B	H	1025	.20	Cap Tube
36HPQ7-E		B	H	1000	.20	.063 (2)
36HPQ7-F		B	H	1000	.20	.063 (2)
42HPQ4-D	BC48A	B	L	1280	.50	Cap Tube
42HPQ4-E		B	H	1375	.45	Cap Tube
42HPQ4-F		B	H	1375	.45	Cap Tube
48HPQ5-G	BC48A	B	H	1375	.45	Cap Tube
48HPQ5-E		B	H	1375	.45	Cap Tube
48HPQ5-F		B	H	1375	.45	Cap Tube
60HPQ5-G	BC60A	B	H	1550	.30	Cap Tube
60HPQ5-E		B	H	1550	.30	Cap Tube
60HPQ5-F		B	H	1550	.30	Cap Tube

(1) Indoor coil type B = Blower coil

(2) Orifice change required for indoor coil to orifice size shown. Correct orifice shipped with condensing unit and packaged with installation instructions for unit.

(3) Static pressure loss for add-on "A" coils and available static pressure for duct systems on blower coils

TABLE 3

SPECIFICATIONS--SPLIT HEAT PUMP

MODEL	24HPQ6-D	30HPQ6-D	36HPQ7-D	36HPQ7-E	36HPQ7-F	42HPQ4-D	42HPQ4-E	42HPQ4-F
Electrical Rating (50Hz/V/Ph)	240/220- 1	240/220- 1	240/220- 1	240/200- 3	415/380- 3	240/220- 1	240/200- 3	415/380- 3
Operating Voltage Range	198-254	198-254	198-254	180-254	342-456	198-254	180-254	342-456
Minimum Circuit Ampacity	15	19	26	17	15	26	17	15
*Delay Fuse Max. Or Ckt. Bkr.	20	30	40	25	15	45	25	15
Total Unit Amps	11.5	15.4	20.8	13.4	7.9	21.1	13.7	7.7
COMPRESSOR								
Volts	240/220	240/220	240/220	220/200	415/380	240/220	240/200	415/380
Rated Load Amps	10	14	19.4	12	6.5	19.4	12	6
Branch Ckt. Selection Current	10	14	19.4	12	6.5	19.4	12	6
Lock Rotor Amps	54	61	87	74	37	87	74	37
FAN MOTOR AND CONDENSER								
Fan Motor--HP/RPM	1/5-1100	1/5-1090	1/5-1090	1/5-1090	1/5-1090	1/3-900	1/3-900	1/3-900
Fan Motor--Amps	1.5	1.4	1.4	1.4	1.4	1.7	1.7	1.7
Fan--Dia./CFM	18"-1850	20"-2050	20"-2050	20"-2050	20"-2050	24"-3600	24"-3600	24"-3600
Face Area Sq. Ft./Row/	3.75/3	5.04/3	5.04/3	5.04/3	5.04/3	7.7/2	7.7/2	7.7/2
Fins Per Inch	14	14	14	14	14	14	14	14
Factory Charge R-22 Oz.	61	73	88	88	88	88	88	88
Shipping Weight Lbs.	180	210	220	220	220	261	258	258
* Maximum time delay fuse or HACR Type circuit breaker.								

MODEL	48HPQ5-G	48HPQ5-E	48HPQ5-F	60HPQ5-G	60HPQ5-E	60HPQ5-F
Electrical Rating (50Hz/V/Ph)	220/200- 1	240/200- 3	415/380- 3	220/200- 1	240/220- 3	415/380- 3
Operating Voltage Range	180-242	180-254	342-456	180-242	180-254	342-456
Minimum Circuit Ampacity	29	19	15	44.8	27	16
*Delay Fuse Max. Or Ckt. Bkr.	50	30	15	70	50	25
Total Unit Amps	23.2	15	8.2	36.2	21.7	12.3
COMPRESSOR						
Volts	220/200	240/200	415/380	220/200	240/220	415/380
Rated Load Amps	21.5	13.3	6.5	34.5	20	10.6
Branch Ckt. Selection Current	21.5	13.3	6.5	34.5	20	10.6
Lock Rotor Amps	116	92	46	179	135	70
FAN MOTOR AND CONDENSER						
Fan Motor--HP/RPM	1/3-900	1/3-900	1/3-900	1/3-900	1/3-900	1/3-900
Fan Motor--Amps	1.7	1.7	1.7	1.7	1.7	1.7
Fan--Dia./CFM	24"-3400	24"-3400	24"-3400	24"-3400	24"-3400	24"-3400
Face Area Sq. Ft./Row/	7.7/3	7.7/3	7.7/3	7.7/3	7.7/3	7.7/3
Fins Per Inch	12	12	12	12	12	12
Factory Charge R-22 Oz.	122	122	122	112	112	112
Shipping Weight Lbs.	275	272	272	291	283	283
* Maximum time delay fuse or HACR Type circuit breaker.						

I. APPLICATION AND LOCATION

GENERAL

These instructions explain the recommended method to install the air cooled remote type outdoor unit, the interconnecting refrigerant tubing and the electrical wiring connections to the unit.

The outdoor units are to be used in conjunction with the matching indoor coils or indoor blower coil for comfort cooling/heating applications as shown in the specification sheet.

These instructions and any instructions packaged with any separate equipment required to make up the entire system should be carefully read before beginning the installation. Note particularly "Connecting Quick-Connect Couplings, Starting Procedure" and any tags and/or labels attached to the equipment.

While these instructions are intended as a general recommended guide, they do not supersede any national and/or local codes in any way. Authorities having jurisdiction should be consulted before the installation is made.

SHIPPING DAMAGE

Upon receipt of equipment, the carton should be checked for external signs of shipping damage. If damage is found, the receiving party must contact the last carrier immediately, preferably in writing, requesting inspection by the carrier's agent.

APPLICATION

Size of unit for a proposed installation should be based on heat loss calculation made according to methods of Air Conditioning Contractors of America. The air duct should be installed in accordance with the Standards of the National Fire Protection Association for the Installation of Air Conditioning and Ventilating Systems of Other Than Residence Type, NFPA No. 90A and Residence Type Warm Air Heating and Air Conditioning Systems, NFPA No. 90B. Where local regulations are at a variance with instructions, installer should adhere to local codes.

For applications in Canada, the installation of the system must be made in accordance with CSA Standards C22.1, Canadian Electrical Code, Part I; C273.5 Installation Requirements for Air-To-Air Heat Pumps; and B52, Mechanical Refrigeration Code.

LOCATION

The outdoor unit is designed to be located outside with free and unobstructed outdoor coil air inlet and discharge. It must also permit access for service and installation. Outdoor air enters the coil on three sides and discharges upward from the top. Refrigerant and electrical connections are made from the rear of the unit as shown in Figure 3 with electrical service access on the right side.

SETTING THE UNIT

GENERAL--The unit must be located outside, or in a well ventilated area. It must not be in the space being heated or cooled. A sound absorbing material should be considered if the unit is to be installed in such a position or location that might cause transmission of sound or vibration to the living area or adjacent buildings.

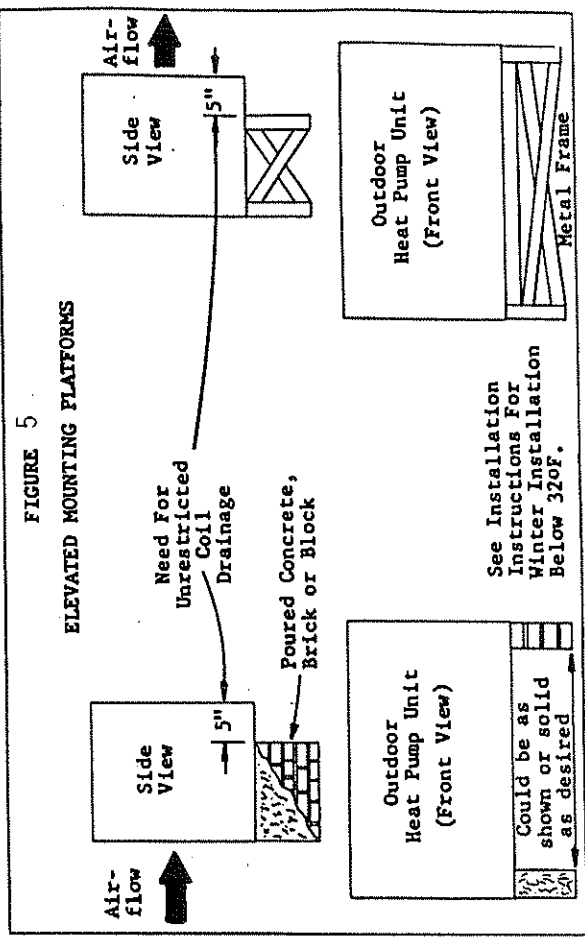
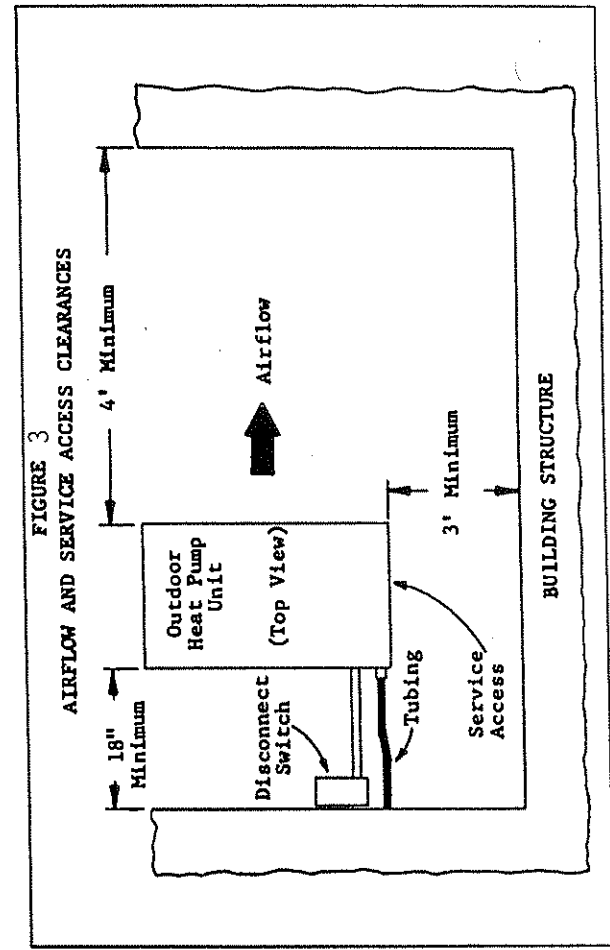
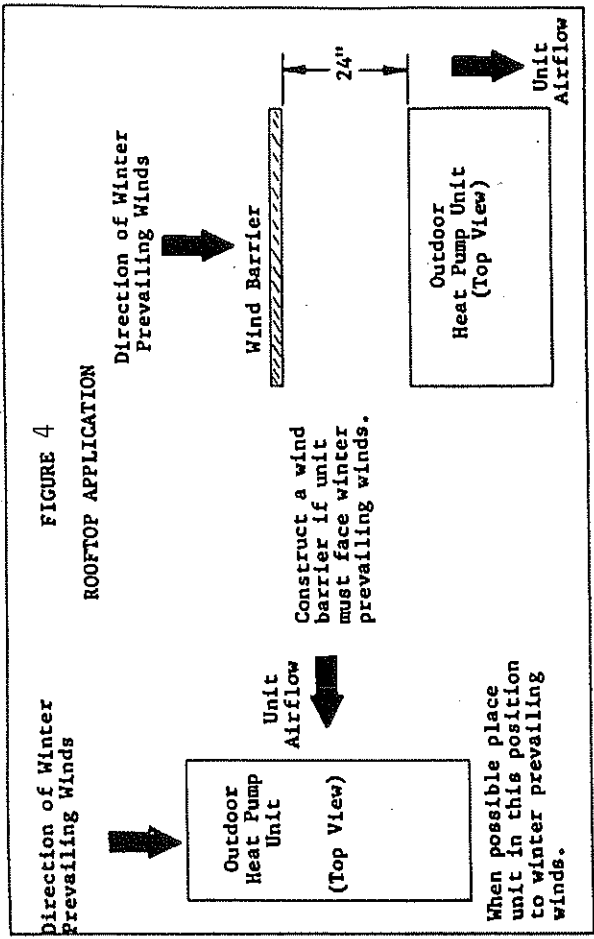
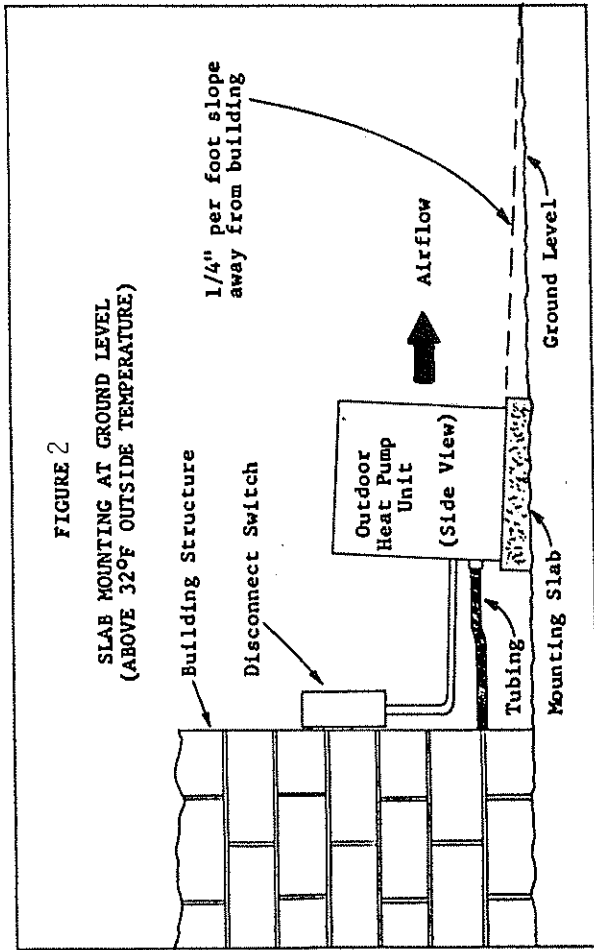

SLAB MOUNTING

In areas where winter temperatures DO NOT go below 32° F for periods over twelve hours, the unit may be slab mounted at grade level. When installing the unit at grade level, install on a concrete slab at least four inches above finished grade level. Slab should have a slope tolerance away from the building structure of at least 1/4 inch per foot, while being level from side to side. This will prevent ice buildup under the unit during defrost cycles. Place slab in a location where run-off water from higher ground will not collect around unit. See Figure 2.

A minimum clearance should be provided between the coil inlet and any building surfaces. Provide at least four feet between coil outlet and any structures. Provide a minimum of 8 inches clearance on the service access side of the unit. Refer to Figure 3.

ROOF MOUNTING

When a unit is installed in areas where low ambient temperatures or strong winter winds exist, it should be placed so prevailing winter winds are not in direct line with the heat pump coil. If this is not possible, a wind barrier should be constructed. Place barrier 24 inches from the coil side of the unit and in the direction of the prevailing winds. Size barrier at least the same height and 6 to 12 inches wider than unit. See Figure 4.

WINTER INSTALLATION BELOW 32° F

In areas where winter conditions go below 32° F for extended periods, the unit must be elevated above the mounting surface to prevent snowfall or defrost ice accumulation from interfering with the operation of the unit. A minimum of twelve inch elevation is recommended, while greater elevation may be required for areas of high snow accumulation. For ease of installation, a heat pump stand is available from Bard. Poured concrete, steel framework, brick, cement block, etc. can be utilized to construct a suitable raised mounting platform. See Figure 5. The mounting platform must provide support on all 5 dimples located on the unit base and must not rest against the unit base.

IMPORTANT INSTALLER NOTE

For improved start-up performance, wash the indoor coil with a dishwasher detergent.

FIGURE 6

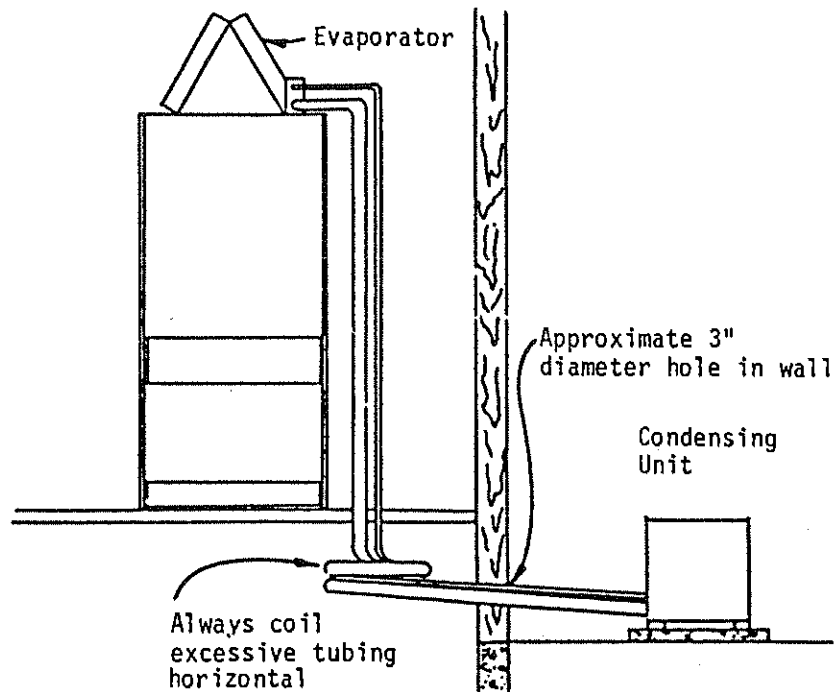

INSTALLING REFRIGERANT TUBING

PRECHARGED TUBING CONNECTIONS (1)

Examine carefully the two lengths of precharged tubing furnished with the system. The larger is the suction line and the smaller is the liquid line. The end of the tubing with the hex nut and gauge port is to be attached to the outdoor unit.

STEP 1--Unroll the tubing, being careful not to kink, and route both the suction line and liquid line between the indoor unit and outdoor unit.

Before fastening either end, use a tubing bender to make any necessary bends in tubing. When necessary to bend the insulated tube suction line, cut the insulation around its circumference at a distance for enough beyond the point of the bend so as to clear the tubing bender. Slip the insulation back together and vapor seal the joint with tape. Coil any excess tubing in a horizontal place with the slope of the tubing toward the condensing unit.

CAUTION: 1. Be careful not to tear the insulation when pushing it through holes in masonry or frame walls. 2. When sealing tube opening in house wall, use a soft material to prevent tube damper and vibration transmission. 3. Avoid excessive bending in any one place to avoid kinking.

STEP 2--Remove protector caps and plugs, inspect fittings and if necessary carefully wipe coupling seats and threaded surfaces with a clean cloth to prevent the inclusion of dirt or any foreign material in the system.

STEP 3--Lubricate male half diaphragm and synthetic rubber seal with refrigerant oil. Starting with the indoor coil thread coupling halves together by hand to insure proper mating of threads. Be sure to hold the coupling firmly to prevent movement of the coupling and tubing. Failure to do so could tear out the diaphragm causing a blockage of the system. Use proper size wrenches (on coupling body hex and on union nut) and tighten until coupling bodies "bottom" or a definite resistance is felt.

CAUTION: After starting to tighten up the fitting, never try to back it off or take it apart.

STEP 4--Using a marker or ink pen, mark a line lengthwise from the coupling union nut to the bulkhead. Then tighten an additional 1/4 turn: The misalignment of the line will show the amount the coupling has been tightened. This final 1/4 turn is necessary to insure the formation of leak proof joint. If a torque wrench is used, the following torque values are recommended:

TABLE 4

Coupling Size	Ft. Lbs.
-6	10 - 12
-10	35 - 45
-11	35 - 45
-12	50 - 65

Repeat Step 3 and 4 on outdoor section making sure to locate the gauge port in a 45° angle from a vertical up position so as to be accessible for gauge connections.

STEP 5--Leak test all connections using an electronic leak detector or a halide torch.

STEP 6--When tubing is installed in attics or drop ceilings, insulate the couplings on the larger tube thoroughly with 3/8" wall thickness, closed cell sponge tube insulation or equivalent. Failure to insulate will result in water damage to ceiling since the fitting will "sweat" and drop water on the ceiling.

(1) **NOTE:** The maximum distance for precharged tubing between the outdoor and indoor unit is 45 feet.

SWEAT STYLE TUBING CONNECTIONS

Use only refrigeration grade (dehydrated and sealed) copper tubing. Care must be taken to insure that the tubing is kept clean and dry before and during installation. Do not remove the plugs from the tubing ends, coil connections or base valves until the connection is ready to be brazed.

The suction line must be insulated with a minimum of 3/8" Armaflex or equivalent before cutting and making connections.

STEP 1--Being careful not to kink, route both the suction line and liquid line between the indoor unit and outdoor unit. Use a tubing bender to make any necessary bends in tubing. When necessary to bend the insulated tube suction line, cut the insulation around its circumference at a distance far enough beyond the point of the bend so as to clear the tubing bender. Slip the insulation back together and vapor seal the joint with tape. Coil any excess tubing in a horizontal place with the slope of the tubing toward the condensing unit.

CAUTION: 1. Be careful not to tear the insulation when pushing it through holes in masonry or framewalls. 2. When sealing tube opening in house wall, use a soft material to prevent tube damage and vibration transmission. 3. Avoid excessive bending in any one place to avoid kinking.

STEP 2--The tubing ends should be cut square. Make sure it is round and free of burrs at the connecting ends. Clean the tubing to prevent contaminants from entering the system.

STEP 3--Wrap a wet rag around the copper stub before brazing.

STEP 4--Flux the copper tube and insert into the stub. Braze the joint using an alloy of silver or copper and phosphorus with a melting temperature above 1100° F for copper to copper joints. The phosphorus will act as a flux, therefore, no flux will be required.

A copper-silver ally with a high silver content should be used when iron or steel material is involved in the joint. These alloys require the use of silver solder flux. Alloys containing phosphorus should not be used with iron or steel. Phosphorus reacts with the iron, forming iron phosphate which is extremely brittle.

CAUTION: 1. Brazing alloys with a melting temperature below 700° F should not be used. 2. Lead-tin or tin-antimony solders should not be used due to their low melting point and necessity for corrosive fluxes.

To further prevent the formation of copper oxide inside the tubing, dry nitrogen may be purged through the refrigerant system during brazing.

WARNING: Never purge or pressurize a system with oxygen. An explosion and fire will result.

STEP 5--After brazing, quench with wet rag to cool the joint and remove any flux residue.

STEP 6--Leak test all connections using an electronic leak detector or a halide torch.

SEQUENCE OF OPERATION WHEN USED WITH INDOOR BLOWER COIL

COOLING--Circuit R-Y makes at thermostat pulling in compressor contactor starting the compressor and outdoor motor. The G (indoor motor) circuit is automatically completed on any call for cooling operation, or can be energized by manual fan switch on subbase for constant air circulation.

HEATING--A 24V solenoid coil on reversing valve controls heating cycle operation. Two thermostat options, one allowing "Auto" changeover from cycle to cycle and the other constantly energizing solenoid coil during heating season and thus eliminating pressure equalization noise except during defrost, are to be used. On "Auto" option, a circuit is completed from R-W1 and R-Y on each heating "on" cycle, energizing reversing valve solenoid and pulling in compressor contactor starting compressor and outdoor motor. R-G also make starting indoor blower motor. Heat pump heating cycle is now in operation. The second option has no "Auto" changeover position, but instead energizes the reversing valve solenoid constantly whenever the system switch on subbase is placed in "heat" position, the "B" terminal being constantly energized from R. A thermostat demand for heat completes R-Y circuit, pulling in compressor contactor starting compressor and outdoor motor. R-G also make starting indoor blower motor.

GENERAL OPERATION--HEAT PUMP/FOSSIL FUEL FURNACE

TABLE 5

Part No.	Model No.	Description
8403-017	T874R1129	THERMOSTAT--1 stg. cool, 2 stg. heat, 1st stage fixed, 2nd stg. adj. heat anticipators
8404-009	Q674L1181	SUBBASE --System switch: Em. Heat-Heat-Off-Cool Fan switch: On-Auto SPECIAL FEATURE: Manual Changeover (Non-Cycling Rev. Valve) Em. heat light and System check light
8403-018	T874N1024	THERMOSTAT--1 stg. cool, 2 stg. heat, 1st stage fixed, 2nd stg. adj., heat anticipators
8404-010	Q674F1261	SUBBASE --System switch: Off-Cool-Auto-Heat-Em.Ht. Fan switch: On-Auto SPECIAL FEATURE: Auto system changeover, Em. heat light and System check light
8403-024	IF58-45	THERMOSTAT--1 stg. cool, 2 stg. heat, 1st stage fixed, 2nd stg. adj. heater System switch: Em. Heat-Heat-Off-Cool Fan Switch: On-Auto
8403-027	IF92-1	THERMOSTAT--2 stg. cool, 3 stg. heat, electronic SUBBASE --Manual or automatic changeover, 2 set-up/set-back periods per day, 5 or 7 day programming.

IMPORTANT NOTE: All thermostat and subbase combinations except IF92-1 shown above incorporate the following features: Man-Auto fan switch, Off-Heat-Cool-Em. Heat Switch, and two (2) indicator lamps--one for emergency heat and one for compressor malfunction.

THERMOSTAT INDICATOR LAMPS

The red lamp marked "Em.Ht." comes on and stays on whenever the system switch is placed in the emergency heat position. The green lamp marked "check" will come on if there is any problem that prevents the compressor from running when it is supposed to be.

DEFROST CYCLE

The defrost cycle is controlled by time and temperature. The 24 volt timer motor runs all the time the compressor is in operation. When the outdoor temperature is in the lower 40°F temperature range or colder, the outdoor coil temperature is 32°F or below. This temperature is sensed by the defrost thermostat mounted near the bottom of the outdoor coil on a return bend. The defrost thermostat closes at approximately 32°F. Every 60 (or 30) minutes that the compressor is running, contacts 3 - 5 close for 7 minutes, with contacts 3 - 4 closed for the first 40 seconds of that 7 minutes. If the defrost thermostat is closed, the defrost relay energizes and places the system in defrost mode. An interlocking circuit is created with timer contacts 3 - 5 and defrost relay contacts 7 - 9 in series.

During the defrost mode, the refrigerant cycle switches back to the cooling cycle, the outdoor motor stops, electric heaters are energized, and hot gas passing through the outdoor coil melts any accumulated frost. When the temperature rises to approximately 57°F, the defrost thermostat opens, de-energizing the defrost relay and returning the system to heating operation.

If some abnormal or temporary condition such as a high wind causes the heat pump to have a prolonged defrost cycle, contacts 3 - 5 of the defrost timer will open after 7 minutes and restore the system to heating operations automatically.

There are two time settings on the defrost timer--30 minutes and 60 minutes. Most models are shipped wired on the 60 minute setting for greatest operating economy. If special circumstances require a change to the shorter time, remove wire connected to terminal 5/60 and reconnect to terminal 5/30.

There is a manual advance knob located on the timer. This can be used to advance timer to contact closure point if it is desired to check out defrost cycle operation, without waiting for time to elapse.

FIGURE 8
DEFROST TIMER WIRING

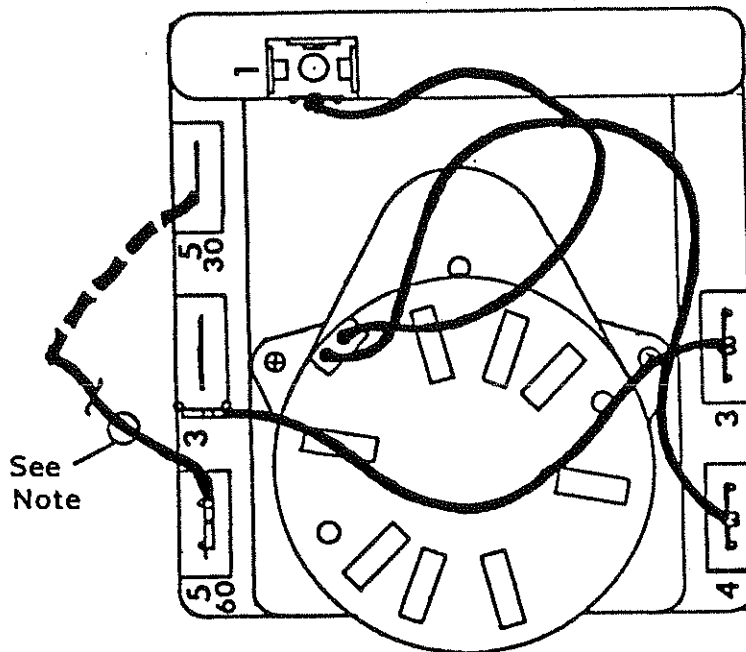

NOTE: All models are connected to 5/60 terminal (60 minute). Any model can be changed from 60 minutes to 30 minutes by unplugging from 5/60 terminal and reconnecting to 5/30 terminal as shown by dotted line.

CRANKCASE HEATERS

All units are provided with some form of compressor crankcase heat. Some single phase units utilize the compressor motor start winding in series with a portion of the run capacitor to generate heat within the compressor shell to prevent liquid refrigerant migration.

Some three phase units utilize a wraparound type of crankcase heater that warms the compressor oil from the outside.

Some single and three phase models have an insertion well-type heater located in the lower section of the compressor housing. This is a self-regulating type heater that draws only enough power to maintain the compressor at a safe temperature.

Some form of crankcase heat is essential to prevent liquid refrigerant from migrating to the compressor, causing oil pump out on compressor start-up and possible valve failure due to compressing a liquid.

Refer to unit wiring diagram to find exact type of crankcase heater used.

The decal in Figure 9 is affixed to all outdoor units detailing start-up procedure. This is very important. Please read carefully.

FIGURE 9

IMPORTANT

THESE PROCEDURES MUST BE FOLLOWED AT INITIAL START-UP AND AT ANY TIME POWER HAS BEEN REMOVED FOR 12 HOURS OR LONGER.

TO PREVENT COMPRESSOR DAMAGE WHICH MAY RESULT FROM THE PRESENCE OF LIQUID REFRIGERANT IN THE COMPRESSOR CRANKCASE

1. MAKE CERTAIN THE ROOM THERMO STAT IS IN THE 'OFF' POSITION. (THE COMPRESSOR IS NOT TO OPERATE).
2. APPLY POWER BY CLOSING THE SYSTEM DISCONNECT SWITCH THIS ENERGIZES THE COMPRESSOR HEATER WHICH EVAPORATES THE LIQUID REFRIGERANT IN THE CRANKCASE.
3. ALLOW 4 HOURS OR 60 MINUTES PER POUND OF REFRIGERANT IN THE SYSTEM AS NOTED ON THE UNIT RATING PLATE WHICHEVER IS GREATER.
4. AFTER PROPERLY ELAPSED TIME THE THERMOSTAT MAY BE SET TO OPERATE THE COMPRESSOR.
5. EXCEPT AS REQUIRED FOR SAFETY WHILE SERVICING — DO NOT OPEN SYSTEM DISCONNECT SWITCH.

7961-061

EMERGENCY HEAT POSITION

The operator of the equipment must manually place the system switch in this position. This is done when there is a known problem with the outdoor section, or when the green "check" lamp comes on indicating a problem.

III. CHARGING INSTRUCTIONS

PRESSURE SERVICE PORTS

High and low pressure service ports are installed on all units so that the system operating pressures can be observed. Pressure tables can be found later in the manual covering all models. It is imperative to match the correct pressure table to the unit by model number.

The pressure service ports on the split system heat pump are located on the interconnecting tubing quick connect fittings. An additional low side service port is located on the compressor suction line for low side pressure during heating operation.

REFRIGERANT CHARGE

The correct system R-22 is shown on the unit rating plate. Optimum unit performance will occur with a refrigerant charge resulting in a suction line temperature (6" from compressor) as shown in the following table:

TABLE 6

Models	Rated Airflow	95°F O.D. Temperature	82°F O.D. Temperature
24HPQ6/BC24B	650	58 - 60	59 - 61
30HPQ6/BC30B	700	62 - 64	67 - 69
30HPQ6/BC35B	900	53 - 55	63 - 65
30HPQ6/BC36B	900	68 - 70	73 - 75
36HPQ7/BC35B	1025	50 - 52	64 - 66
36HPQ7/BC36B	1000	51 - 53	64 - 66
42HPQ4/BC48A	1280	58 - 60	67 - 69
48HPQ5/BC48A	1375	54 - 57	67 - 69
60HPQ5/BC60A	1550	56 - 58	65 - 67

NOTE: The suction line temperatures are based upon 80° F dry bulb/67° F wet bulb (50% R.H.) temperature and rated air flow across the indoor coil during cooling cycle.

TOTAL SYSTEM CHARGE FOR SPLIT SYSTEMS

TABLE 7

TOTAL SYSTEM OPERATING CHARGE (Includes charge for the basic outdoor unit, indoor coil and 25' of interconnecting tubing)		
Outdoor Section	Indoor Section	Total R-22 Charge (Oz.)
24HPQ6	BC24B	74 oz.
30HPQ6	BC30B	96.5 oz.
	BC35B	89 oz.
	BC36B	122 oz.
36HPQ7	BC35B	104 oz.
	BC36B	137 oz.
42HPQ4	BC48A	119 oz.
48HPQ5	BC48A	153 oz.
60HPQ5	BC60A	163 oz.

The above includes 25' of 3/8" diameter liquid line. For other than 25' and other tube sizes, adjust the total charge according to the following schedule.

<u>Liquid Line Diameter</u>	<u>Oz. R-22 Per Ft.</u>
3/8"	.6
1/2"	1.2

INSTALLER NOTE: Stamp or mark the final system charge determined above on the outdoor unit serial plate.

APPLICATION GUIDELINES: For tubing sizes up to 45 feet, use liquid line size and suction line size as shown for precharged tubing sets. For tubing sizes for remote systems between 46 feet and 100 feet in length. Use size recommended in below table based on the 25 foot charged tubing size shown in Table 7.

TABLE 8

Approved 25 Feet Charged Tubing Sizes		Tubing Size Recommended (1)			
		45 - 75 Ft.		76 - 100 Ft.	
Liquid	Vapor	Liquid	Vapor	Liquid	Vapor
1/4"	5/8"	1/4"	3/4"	3/8"	3/4"
1/4"	3/4"	1/4"	7/8"	3/8"	7/8"
3/8"	3/4"	3/8"	7/8"	1/2"	7/8"
3/8"	7/8"	3/8"	7/8"	1/2"	1-1/8"

The basis for selection is to maintain adequate velocity which assures adequate oil return to the compressor, an acceptable pressure drop to assure compressor capacity, and minimum tubing costs.

- (1) These recommendations are based on the use of standard refrigeration tubing.
- (1) Line sizes listed are outside tube dimensions.
- (1) These suggestions do not include consideration for additional pressure drop due to elbows, valves, or reduced joint sizes.
- (1) These recommendations are to be applied to approved combinations of Bard outdoor and indoor sections only.

Charge adjustments for tubing sizes are as follows (2):

1/4" liquid line	.2 oz. R-22 per foot
3/8" liquid line	.6 oz. R-22 per foot
1/2" liquid line	1.2 oz. R-22 per foot

- (2) These values should only be applied during initial system charging. System operating charge should be adjusted for optimum performance outlined in the installation instructions for that model outdoor section.

III. SERVICE

SERVICE HINTS

1. Caution homeowner to maintain clean air filters at all times. Also, not to needlessly close off supply and return air registers. This reduces air flow through the system, which shortens equipment service life as well as increasing operating costs.
2. Switching to heating cycle at 75° F or higher outside temperature may cause a nuisance trip of the reset high pressure switch.
3. The heat pump wall thermostats perform multiple functions. Be sure that all function switches are correctly set for the desired operating mode before trying to diagnose any reported service problems.
4. Check all power fuses or circuit breakers to be sure that they are the correct rating.
5. Periodic cleaning of the outdoor coil to permit full and unrestricted air flow circulation is essential.

TABLE 9

24HP06 COOLING

Air Temperature Entering Outdoor Coil °F

Indoor Section	Return Air Temperature	Pressure	°	°	°	°	°	°	°	°	°
			75	80	85	90	95	100	105	110	115
BC24B	75°DB	Low Side	73	74	75	76	77	78	79	80	81
	62°WB	High Side	200	216	232	248	262	280	296	312	329
	80°DB	Low Side	77	78	80	81	82	83	85	86	87
	67°WB	High Side	206	222	238	255	269	304	304	321	338
	85°DB	Low Side	83	84	86	87	88	89	91	92	93
	72°WB	High Side	212	230	247	264	278	298	315	332	350

TABLE 10

24HP06 HEATING

Air Temperature Entering Outdoor Coil °F

Indoor Section	Return Air Temperature	Pressure	°	°	°	°	°	°	°	°	°	°	°	°	°	°	
			0	5	10	15	17	20	25	30	35	40	45	47	50	55	60
BC24B	70 °D.B.	Low Side	19	22	25	29	30	32	35	39	42	45	49	50	52	55	59
		High Side	136	141	146	152	154	157	162	168	173	178	184	186	189	194	200

TABLE 11

30HP06 COOLING

Air Temperature Entering Outdoor Coil °F

Indoor Model	Return Air Temperature	Pressure	°	°	°	°	°	°	°	°	°
			75	80	85	90	95	100	105	110	115
BC35B	75 deg. DB	Low Side	67	68	70	71	73	74	76	77	78
	62 deg. WB	High Side	193	207	222	236	252	268	284	301	319
	80 deg. DB	Low Side	72	73	75	76	78	79	81	82	83
	67 deg. WB	High Side	199	213	228	243	259	275	292	309	327
	85 deg. DB	Low Side	77	79	81	82	84	85	87	88	89
	72 deg. WB	High Side	206	221	236	251	268	284	301	319	338
BC30B	75 deg. DB	Low Side	60	62	64	66	68	70	72	74	76
	62 deg. WB	High Side	291	232	241	249	258	266	274	283	291
	80 deg. DB	Low Side	63	66	68	70	73	75	77	79	82
	67 deg. WB	High Side	203	220	238	256	274	291	309	327	344
	85 deg. DB	Low Side	68	71	73	75	78	80	82	84	87
	67 deg. WB	High Side	195	213	230	247	265	282	299	316	334
BC36B	75 deg. DB	Low Side	61	65	68	71	73	75	76	77	78
	62 deg. WB	High Side	201	218	235	252	269	286	303	319	336
	80 deg. DB	Low Side	66	70	73	76	78	80	81	82	83
	67 deg. WB	High Side	207	224	241	259	276	293	311	328	345
	85 deg. DB	Low Side	71	75	78	81	83	85	87	88	89
	72 deg. WB	High Side	213	232	250	268	286	304	322	339	357

TABLE 12

30HP06 HEATING

Air Temperature Entering Outdoor Coil °F

Indoor Model	Return Air Temperature	Pressure	°	°	°	°	°	°	°	°	°	°	°	°	°	°	
			0	5	10	15	17	20	25	30	35	40	45	47	50	55	60
BC35B	70°DB	Low Side	14	19	23	28	30	32	36	41	45	48	52	54	56	60	63
		High Side	135	145	155	165	169	175	185	195	205	215	225	229	235	245	255
BC30B	70°DB	Low Side	17	21	25	29	31	33	37	41	45	49	53	55	57	61	65
		High Side	150	160	169	178	182	187	196	205	215	224	233	237	242	251	260
BC36B	70°DB	Low Side	15	19	23	27	29	32	36	40	44	48	52	54	57	61	65
		High Side	142	151	160	168	172	177	186	196	205	214	224	228	239	244	254

Low side pressure \pm 2 PSIG (suction line between accumulator + compressor)High side pressure \pm 5 PSIG (liquid line @ outdoor unit quick connect)

Tables are based upon rated CFM (airflow) across the evaporator coil and should be found under section titled "Refrigerant Charge" elsewhere in manual. If there is any doubt as to correct operating charge being in the system, the charge should be removed, system evacuated, and recharged to serial plate instructions.

TABLE 13

36HPQ7 COOLING

Air Temperature Entering Outdoor Coil °F

Indoor Model	Return Air Temperature	Pressure	°	°	°	°	°	°	°	°	°
			75	80	85	90	95	100	105	110	115
BC35B	75 deg. DB	Low Side	61	63	65	67	68	69	71	72	73
	62 deg. WB	High Side	202	217	233	249	265	281	297	313	330
	80 deg. DB	Low Side	65	67	69	71	73	74	76	77	78
	67 deg. WB	High Side	208	223	239	255	272	288	305	321	339
	85 deg. DB	Low Side	70	72	74	76	78	80	81	82	84
	72 deg. WB	High Side	215	231	247	264	281	300	315	332	350
BC36B	75 deg. DB	Low Side	65	67	69	71	72	73	74	75	76
	62 deg. WB	High Side	232	246	261	275	290	305	320	335	350
	80 deg. DB	Low Side	70	72	74	76	77	78	79	80	81
	67 deg. WB	High Side	239	253	268	282	297	312	327	343	359
	85 deg. DB	Low Side	75	77	79	81	83	84	86	86	87
	72 deg. WB	High Side	248	262	277	292	307	321	338	355	371

TABLE 14

36HPQ7 HEATING

Air Temperature Entering Outdoor Coil °F

Indoor Model	Return Air Temperature	Pressure	°	°	°	°	°	°	°	°	°	°	°	°	°	°	
			0	5	10	15	17	20	25	30	35	40	45	47	50	55	60
BC35B	70° DB	Low Side	20	22	25	27	29	31	34	38	42	46	51	53	56	61	67
		High Side	145	154	163	173	178	184	195	207	219	231	244	250	258	272	286
BC36B	70° DB	Low Side	25	26	27	29	30	32	34	38	42	47	52	54	58	64	71
		High Side	133	145	157	169	174	181	193	205	216	227	239	243	250	261	271

TABLE 15

42HPQ4 COOLING

Air Temperature Entering Outdoor Coil °F

Indoor Model	Return Air Temperature	Pressure	°	°	°	°	°	°	°	°	°
			75	80	85	90	95	100	105	110	115
BC48A	75° DB	Low Side	65	68	71	73	75	77	78	80	81
	62° WB	High Side	194	209	224	240	256	272	289	306	324
	80° DB	Low Side	70	73	75	78	80	82	84	86	87
	67° WB	High Side	199	215	230	247	263	263	280	314	332
	85° DB	Low Side	77	79	81	84	86	88	88	92	94
	72° WB	High Side	207	223	239	255	272	289	307	325	343

TABLE 16

42HPQ4 HEATING

Air Temperature Entering Outdoor Coil °F

Indoor Model	Return Air Temperature	Pressure	°	°	°	°	°	°	°	°	°	°	°	°	°	°	
			0	5	10	15	17	20	25	30	35	40	45	47	50	55	60
BC48A	70° DB	Low Side	17	21	24	28	29	31	35	38	42	45	49	50	52	56	59
		High Side	137	143	149	155	157	161	167	173	179	185	191	193	197	203	209

Low side pressure + 2 PSIG (suction line between accumulator + compressor)

High side pressure + 5 PSIG (liquid line @ outdoor unit quick connect)

Tables are based upon rated CFM (airflow) across the evaporator coil and should be found under section titled "Refrigerant Charge" elsewhere in manual. If there is any doubt as to correct operating charge being in the system, the charge should be removed, system evacuated, and recharged to serial plate instructions.

TABLE 17

48HPQ5 COOLING

Air Temperature Entering Outdoor Coil °F

Indoor Model	Return Air Temperature	Pressure	Air Temperature Entering Outdoor Coil °F								
			75	80	85	90	95	100	105	110	115
BC48A	75 deg. DB	Low Side	65	69	69	71	73	75	77	79	81
	62 deg. WB	High Side	197	212	227	242	257	272	287	302	317
	80 deg. DB	Low Side	70	72	74	76	78	80	82	84	86
	67 deg. WB	High Side	202	218	233	249	264	264	295	310	326
	85 deg. DB	Low Side	75	77	79	82	84	86	89	91	93
	72 deg. WB	High Side	210	226	241	257	273	289	305	320	336
BC60A	75 deg. DB	Low Side	68	71	74	76	78	80	81	82	82
	62 deg. WB	High Side	205	221	236	252	267	282	297	312	326
	80 deg. DB	Low Side	73	76	79	81	83	85	86	87	88
	67 deg. WB	High Side	210	227	243	258	274	289	305	320	335
	85 deg. DB	Low Side	79	82	85	87	89	91	92	94	95
	72 deg. WB	High Side	217	234	251	268	284	300	316	331	346

TABLE 18

48HPQ5 HEATING

Air Temperature Entering Outdoor Coil °F

Indoor Model	Return Air Temperature	Pressure	Air Temperature Entering Outdoor Coil °F														
			0	5	10	15	17	20	25	30	35	40	45	47	50	55	60
BC48A	70 D.B.	Low Side	14	18	22	26	28	30	34	38	42	46	50	52	54	58	62
		High Side	140	147	154	161	164	168	175	182	189	196	203	206	210	217	224
BC60A	70 D.B.	Low Side	14	18	22	26	28	30	34	38	42	46	50	52	54	58	62
		High Side	135	142	149	156	159	163	170	177	184	191	198	201	205	212	219

TABLE 19

60HPQ5 COOLING

Air Temperature Entering Outdoor Coil ° F

Indoor Model	Return Air Temperature	Pressure	Air Temperature Entering Outdoor Coil ° F								
			75	80	85	90	95	100	105	110	115
BC60A	75° DB	Low Side	62	63	65	66	68	70	71	73	74
	62° WB	High Side	220	236	253	269	286	303	319	336	352
	80° DB	Low Side	67	68	70	71	73	75	76	76	79
	67° WB	High Side	225	242	259	276	293	310	327	344	361
	85° DB	Low Side	72	73	75	76	78	80	81	83	84
	72° WB	High Side	234	251	268	286	303	320	338	355	372

TABLE 20

60HPQ5 HEATING

Air Temperature Entering Outdoor Coil °F

Indoor Model	Return Air Temperature	Pressure	Air Temperature Entering Outdoor Coil °F														
			0	5	10	15	17	20	25	30	35	40	45	47	50	55	60
BC60A	70° DB	Low Side	14	18	21	25	26	28	31	35	39	42	46	47	49	53	56
		High Side	144	151	157	163	166	170	176	182	189	195	201	204	208	214	220

Low side pressure \pm 2 PSIG (suction line between accumulator + compressor)

High side pressure \pm 5 PSIG (liquid line @ outdoor unit quick connect)

Tables are based upon rated CFM (airflow) across the evaporator coil and should be found under section titled "Refrigerant Charge" elsewhere in manual. If there is any doubt as to correct operating charge being in the system, the charge should be removed, system evacuated, and recharged to serial plate instructions.

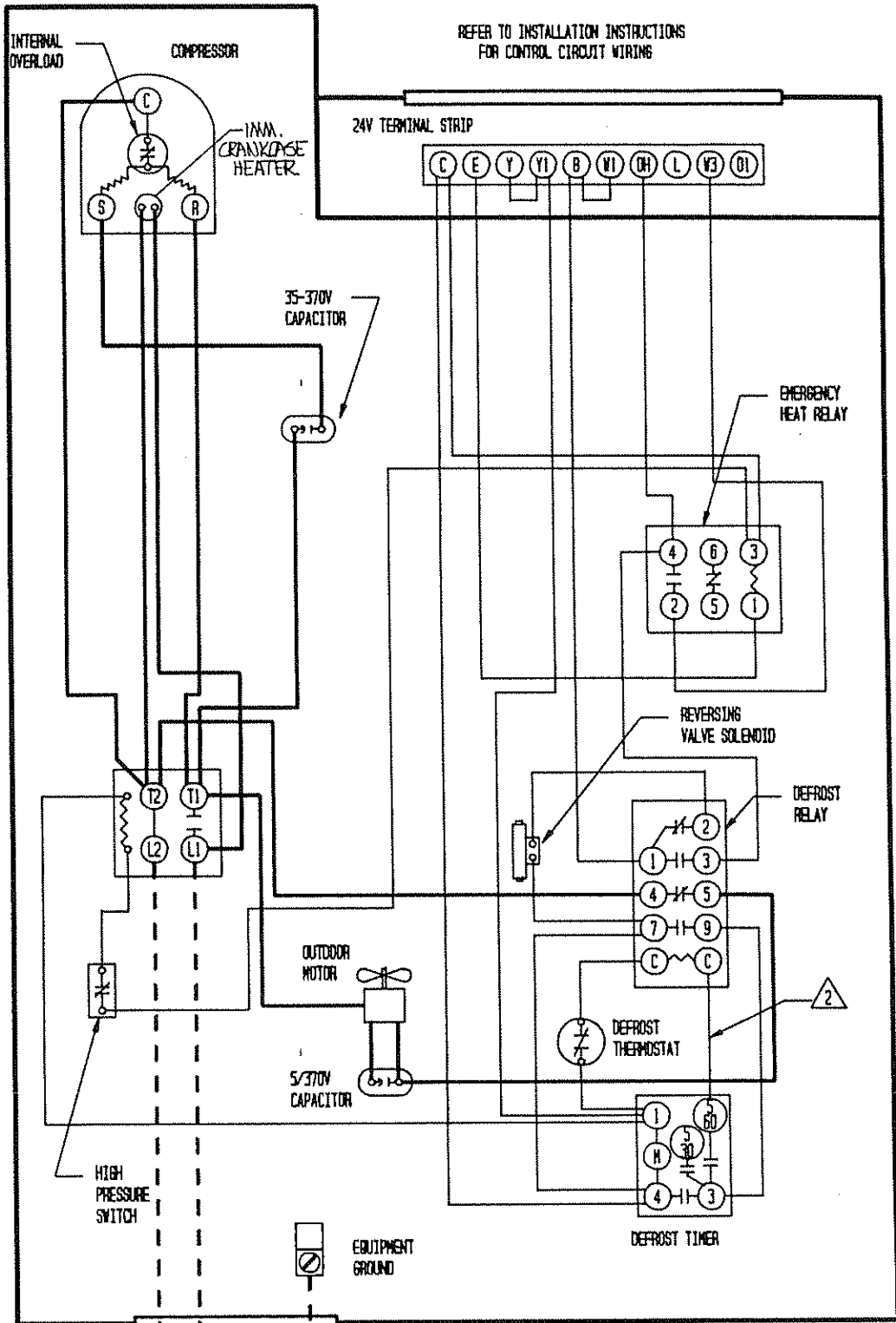

USE COPPER CONDUCTORS ONLY

FUSED DISCONNECT SWITCH

240/220 - 50 - 1

	FACTORY WIRING	FIELD WIRING
Low Voltage	—————	-----
High Voltage	—————	-----

⚠ RECONNECT FROM 5-60 TO 5-30 FOR 30 MINUTE CYCLE.

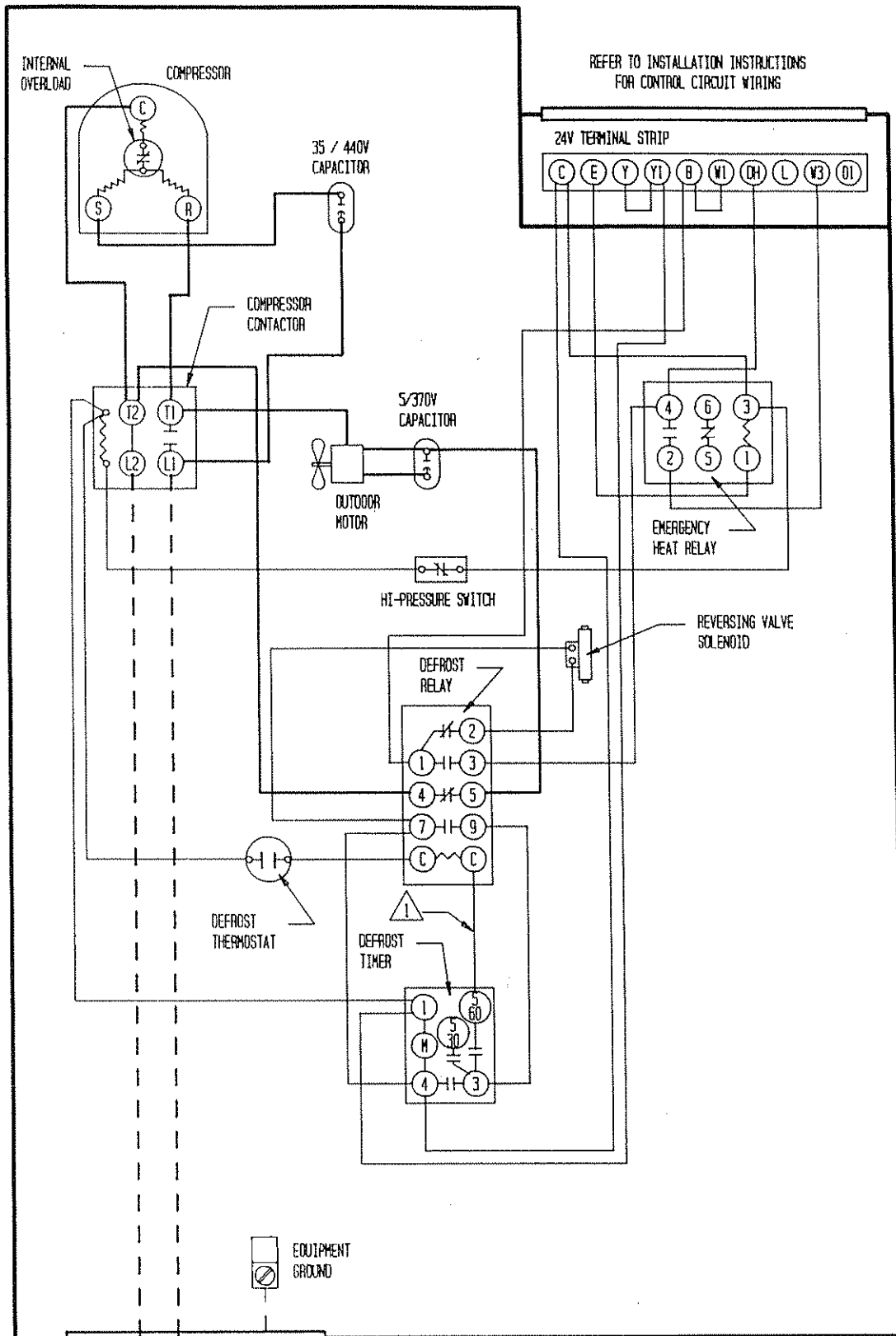

REFER TO INSTALLATION INSTRUCTIONS FOR CONTROL CIRCUIT WIRING

FUSED DISCONNECT SWITCH

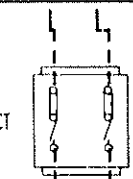

240 / 220 - 50 - 1

USE COPPER CONDUCTORS ONLY

	FACTORY WIRING	FIELD WIRING
Low Voltage	—————	- - - - -
High Voltage	—————	- - - - -

⚠ RECONNECT FROM 5-60 TO 5-30 FOR 30 MINUTE CYCLE

4028-410 H

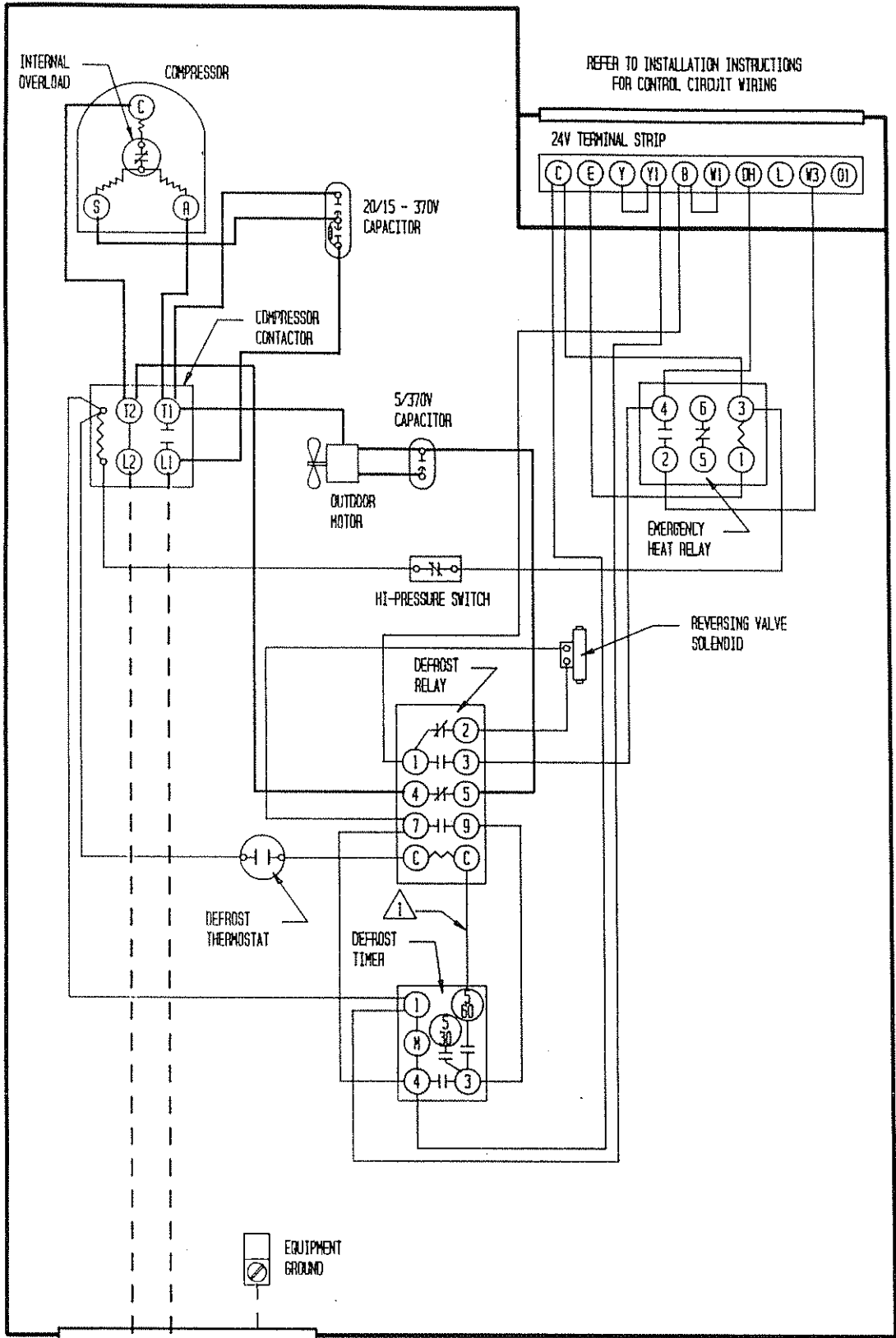

REFER TO INSTALLATION INSTRUCTIONS FOR CONTROL CIRCUIT WIRING

24V TERMINAL STRIP

C E Y Y1 B W1 OH L W3 O1

20/15 - 370V CAPACITOR

5/370V CAPACITOR

HI-PRESSURE SWITCH

DEFROST RELAY

DEFROST TIMER

DEFROST THERMOSTAT

REVERSING VALVE SOLENOID

EMERGENCY HEAT RELAY

EQUIPMENT GROUND

FUSED DISCONNECT SWITCH

USE COPPER CONDUCTORS ONLY

⚠ RECONNECT FROM 5-60 TO 5-30 FOR 30 MINUTE CYCLE

	FACTORY WIRING	FIELD WIRING
Low Voltage	—————	- - - - -
High Voltage	—————	- - - - -

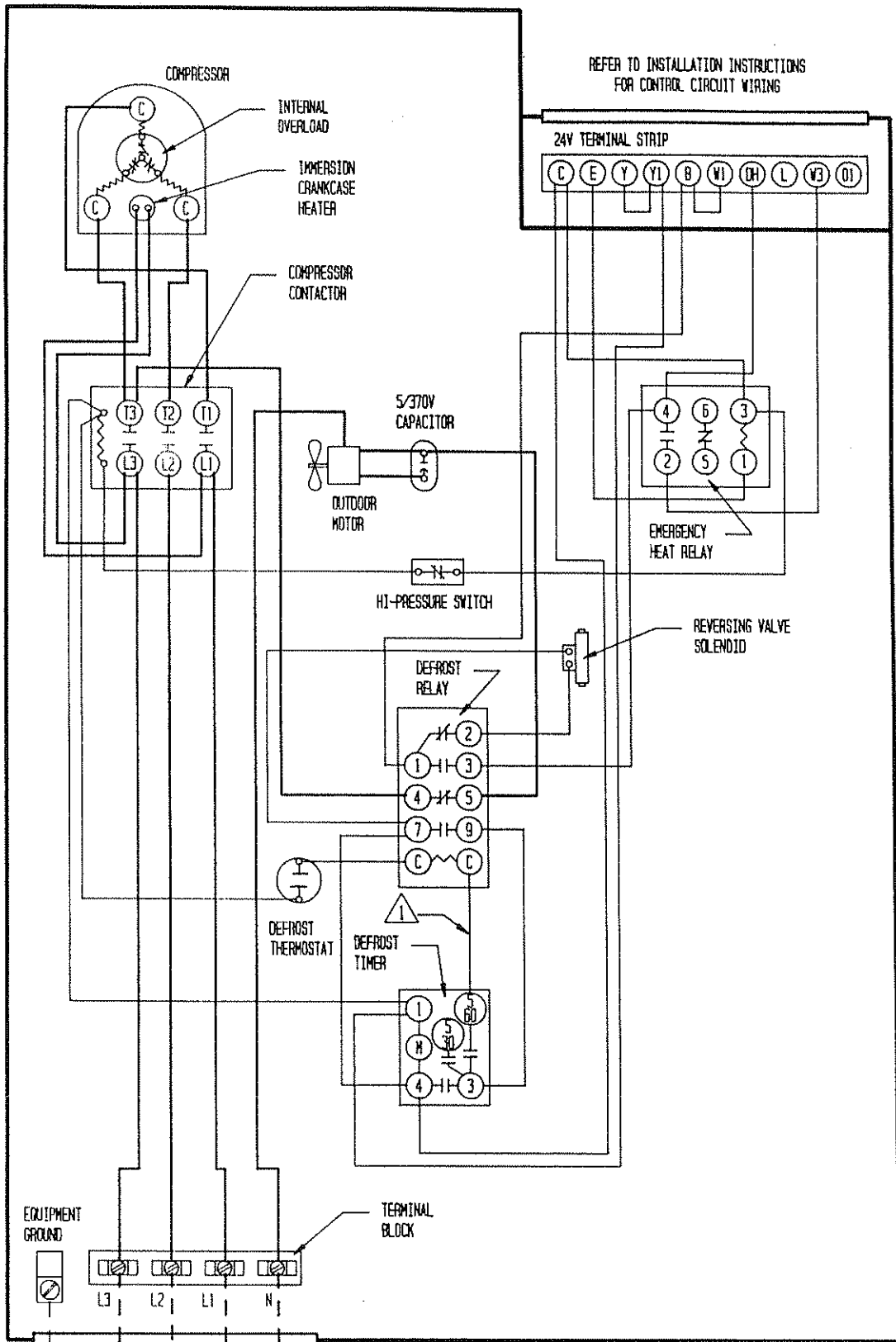

REFER TO INSTALLATION INSTRUCTIONS FOR CONTROL CIRCUIT WIRING

24V TERMINAL STRIP
C E Y Y1 B W1 OH L W3 O1

COMPRESSOR
INTERNAL OVERLOAD
IMMERSION CRANKCASE HEATER
COMPRESSOR CONTACTOR

5/370V CAPACITOR

OUTDOOR MOTOR

HI-PRESSURE SWITCH

EMERGENCY HEAT RELAY

REVERSING VALVE SOLENOID

DEFROST RELAY

DEFROST THERMOSTAT

DEFROST TIMER

EQUIPMENT GROUND

TERMINAL BLOCK

L3 L2 L1 N

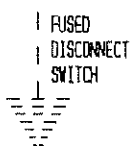

415/380 - 50 - 3

USE COPPER CONDUCTORS ONLY

⚠ RECONNECT FROM 5-60 TO 5-30 FOR 30 MINUTE CYCLE

	FACTORY WIRING	FIELD WIRING
Low Voltage	—————	- - - - -
High Voltage	—————	- - - - -

REFER TO INSTALLATION INSTRUCTIONS
FOR CONTROL CIRCUIT WIRING.

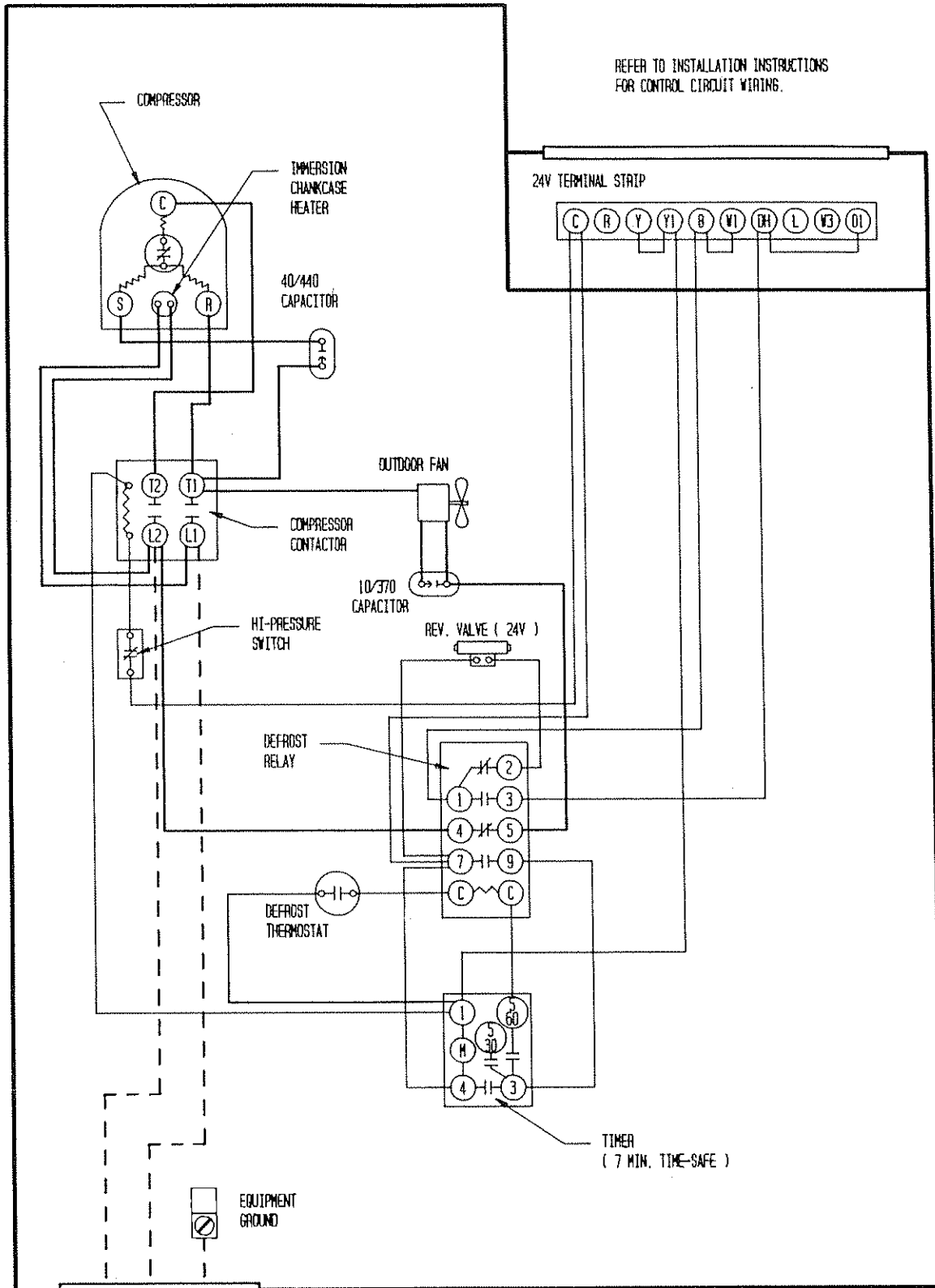

REVERSIBLE
DISCONNECT
SWITCH

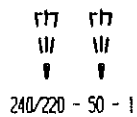
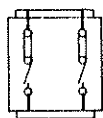

240/220 - 50 - 1

USE COPPER
CONDUCTORS ONLY

	FACTORY WIRING	FIELD WIRING
Low Voltage	— — — —	— — — —
High Voltage	— — — —	— — — —

REFER TO INSTALLATION INSTRUCTIONS
FOR CONTROL CIRCUIT WIRING.

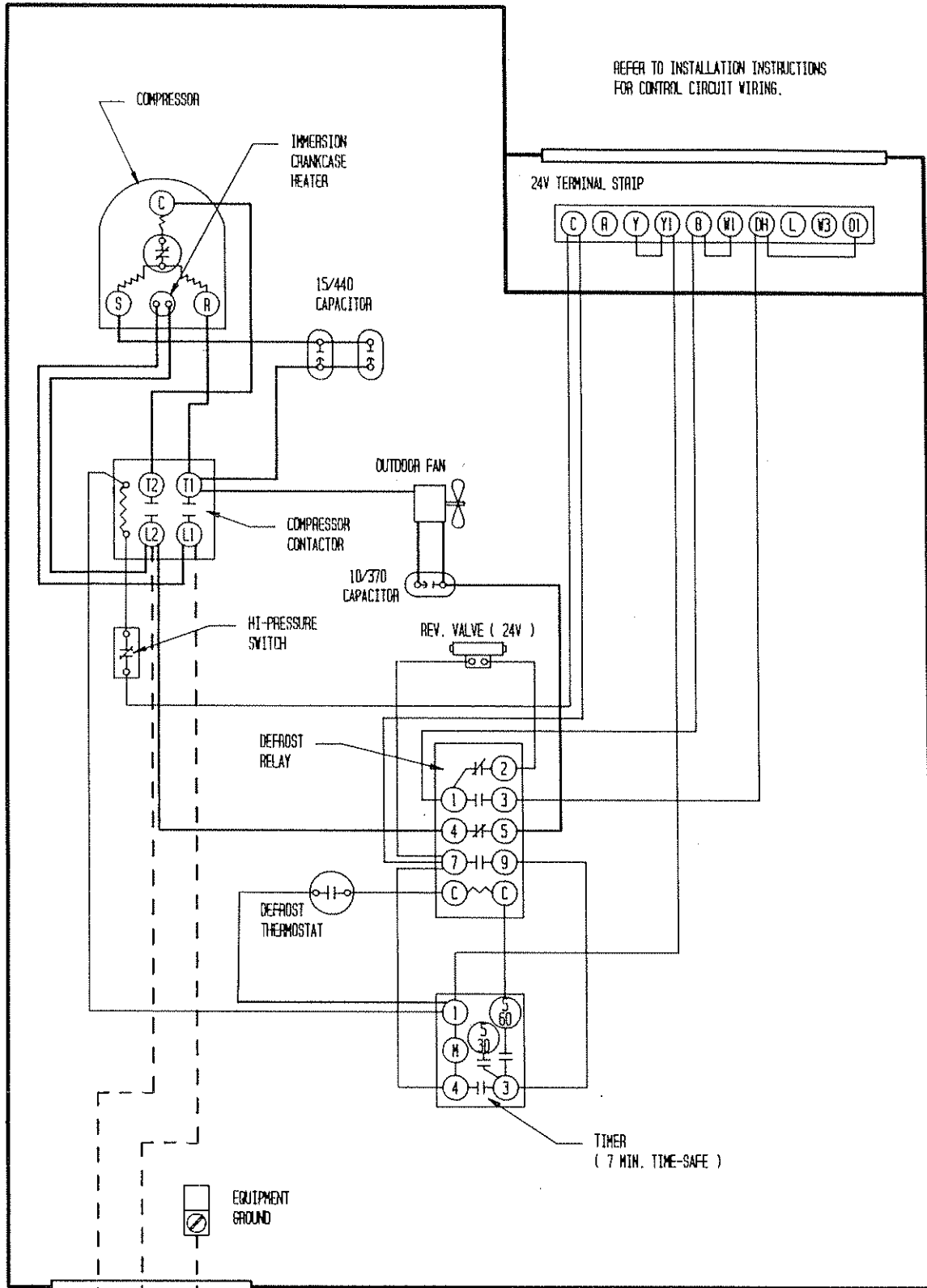

FUSEBLE
DISCONNECT
SWITCH

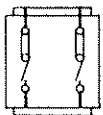

T17 T17
W W

220/200 - 50 - 1

USE COPPER
CONDUCTORS ONLY

	FACTORY WIRING	FIELD WIRING
Low Voltage	—	---
High Voltage	—	---

REFER TO INSTALLATION INSTRUCTIONS
FOR CONTROL CIRCUIT WIRING.

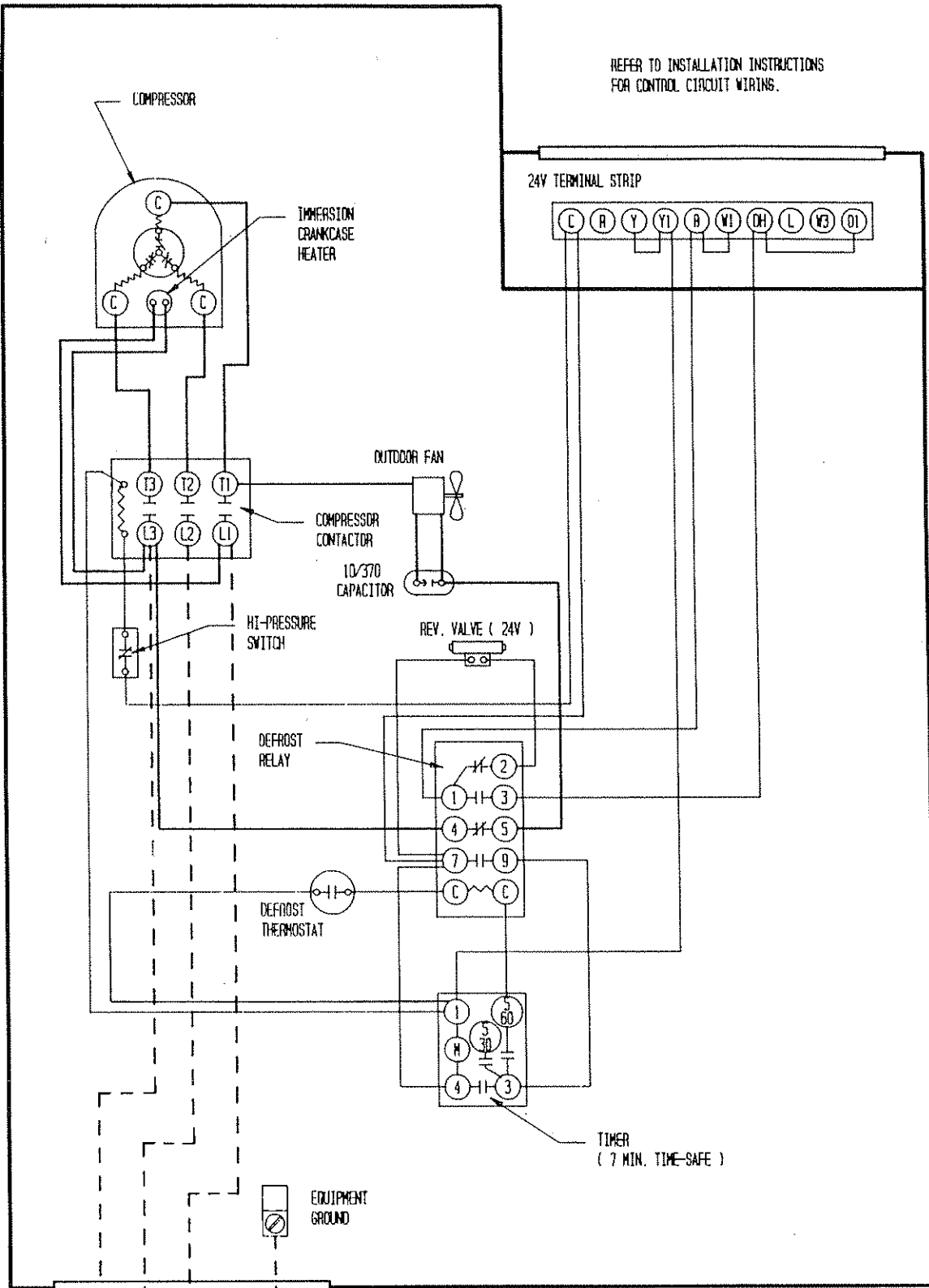

USE COPPER
CONDUCTORS ONLY

	FACTORY WIRING	FIELD WIRING
Low Voltage	—	- - -
High Voltage	—	- - -

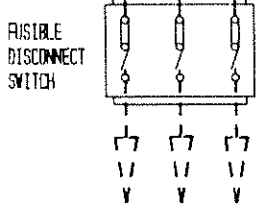

REFER TO INSTALLATION INSTRUCTIONS
FOR CONTROL CIRCUIT WIRING.

